

NASA
TP
1806
c.1

NASA Technical Paper 1806

LOAN COPY: RE
APWL TECHNIC/
KIRTLAND AFB.



Performance of Semi-Transpiration- Cooled Liner in High- Temperature-Rise Combustor

Jerrold D. Wear, Arthur M. Trout,
and John M. Smith

MARCH 1981

NASA



NASA Technical Paper 1806

Performance of Semi-Transpiration-Cooled Liner in High-Temperature-Rise Combustor

Jerrold D. Wear, Arthur M. Trout,
and John M. Smith
*Lewis Research Center
Cleveland, Ohio*



National Aeronautics
and Space Administration

**Scientific and Technical
Information Branch**

1981

Summary

A combustor liner fabricated from Lamilloy was tested at inlet air pressures to 8 atmospheres, an inlet air temperature of 894 K, and exhaust gas temperatures to 2430 K. Results are compared with results obtained with a conventionally designed, film-cooled step-louver liner.

Temperature-indicating paint on the Lamilloy liner showed uniform color, except for panel welds, when operated at the 894 K inlet air temperature and a 1700 K exhaust gas temperature. This uniformity indicated minimum thermal gradients throughout the liner. The color of the paint on the welds indicated a temperature of about 180 kelvins above the inlet air temperature. The paint color on the Lamilloy adjacent to the welds indicated lower metal temperature.

When the exhaust gas temperature was increased to 2215 K, the paint colors streaked, indicating substantial changes in metal temperature. Thermocouples installed in the Lamilloy panel welds showed temperatures about 380 kelvins above the inlet air temperature. A step-louver liner operated at comparable conditions showed metal temperatures about 460 kelvins above the inlet air temperature.

A change in fuel module design and blockage was made to increase the pressure loss differential across the Lamilloy liner in order to increase the cooling airflow through the liner. This change increased the Lamilloy cooling airflow from 9.2 to 13.7 percent of the total airflow.

Exhaust gas temperatures to 2430 K were obtained with these fuel modules with the 894 K inlet air temperature. At these conditions Lamilloy liner metal temperatures were about 280 kelvins above the inlet air temperature.

Comparable smoke density data were obtained with both the Lamilloy and step-louver liners. Smoke numbers were below 5 for a fuel-air ratio range of 0.024 to 0.044; they then increased to about 25 as the fuel-air ratio was increased to 0.058.

Introduction

Experimental investigations were conducted with a semi-transpiration-cooled combustor liner fabricated from Lamilloy¹ material. Results were obtained at

pressures to 8 atmospheres and high combustor inlet and exhaust temperatures. Experimental values obtained with the Lamilloy liner are compared with results obtained with a conventionally designed, film-cooled step-louver liner.

The trend for gas turbine combustors is toward high exhaust temperatures at increasing compressor pressure ratios. The need for combustor liners to be durable under these conditions has always been a problem of paramount importance. As pressure and temperature levels have increased, the availability of excess air for increased liner film cooling has declined. In addition, the recent proposal by the Environmental Protection Agency (EPA) to control engine emissions has severely affected the airflow distribution in combustors (ref. 1). More effective liner cooling schemes are needed as the availability of air for liner cooling decreases.

Transpiration cooling of liners is a technique that has the potential to maintain low liner wall temperatures with reduced cooling air. In the past porous metal or wire structures have been used. These have not always exhibited the durability required because the very small passages become plugged with dirt and the surface metal gradually oxidizes, reducing the flow area. An alternative approach has been taken by the Detroit Diesel Allison (DDA) Division of General Motors with a material they call Lamilloy. This material consists of two or more layers of metal bonded together. Air enters from one side through regularly spaced holes, flows through small etched passageways to holes in the next layer of metal, and continues this process until the air exits through regularly spaced holes on the flame side of the liner. The liner is cooled by a combination of effects: the air passing through the liner, and the exit air acting as a film. Since the material surface is only partially covered by film air, this approach may be thought of as semitranspiration cooling.

The results obtained from tests of the Lamilloy liner are compared with the results obtained with a film-cooled step-louver liner. Comparisons are made on the basis of measured liner temperatures and also account for the variation in fuel-injector module type. Test conditions were pressures of 5 to 8 atmospheres at an inlet air temperature of 894 K and exhaust gas average temperatures from 1400 to 2460 K. ASTM Jet-A fuel was used in all the tests.

¹ Lamilloy is a registered trademark of the General Motors Corp., 3044 West Grant Blvd., Detroit, Mich. 48202.

Apparatus

Combustor

The test combustor, shown in figure 1, is an annular design 34.5 centimeters long from the diffuser inlet to the combustor exit plane. Fuel-injector modules are arranged in two circumferential rows, 24 in each row. An indication of this arrangement can be seen in figure 2. The inlet diffuser (fig. 1) is 5.2 centimeters long and has an exit to inlet area ratio of 1.379. The ratio of the annular flow area at the plane of the fuel modules to the diffuser exit area is 6.7. The reference area for this combustor is 0.2474 square meter. All the airflow passes through the fuel modules except that required to cool the liner. The test combustor is shown with

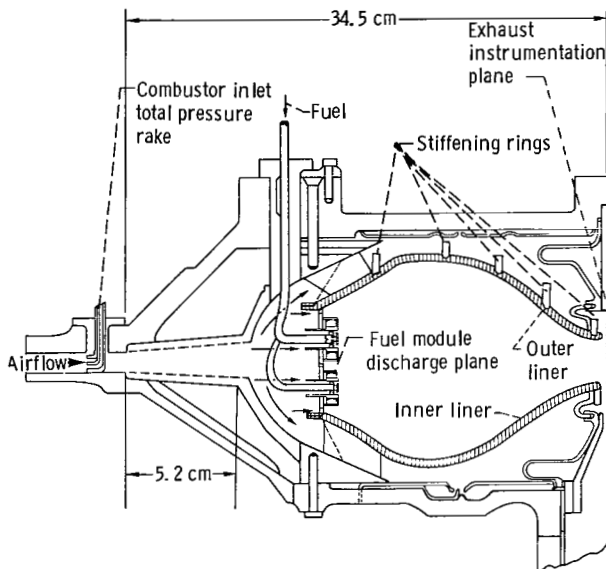

Figure 1. - Combustor test section with Lamilloy liner. (Not to scale.)

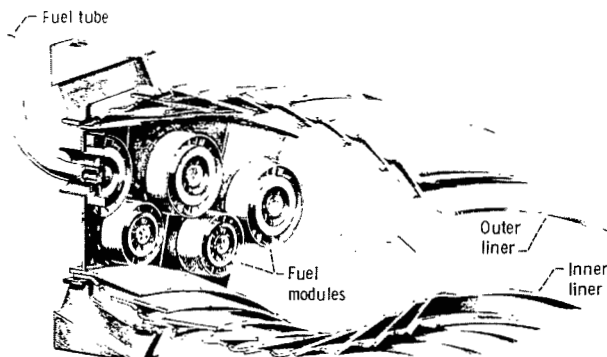

Figure 2. - Fuel modules with step-louver liners.

CD-12209-07

the Lamilloy liner in figure 1 and with a step-louver liner in figure 3.

Fuel Module Design

Two different fuel-injector module designs were used in these tests and are shown in figure 4. Each fuel-injector module consisted of two concentric-vaned air swirlers that swirled the air in opposite directions to create a zone of high shearing action. Fuel was supplied to each module by a fuel tube located in the central cavity of each module (fig. 4(c)). Fuel flowed from the fuel tube and impinged on a splash plate mounted on the downstream face of each module. This splash plate broke up the fuel jet and directed it radially outward, where the fuel was further atomized by air passing through the inner air swirler. Additional fuel atomization occurred in the shearing region between the flows exiting the counterrotating air swirlers.

As indicated in figure 4 the fuel modules were adjusted in size so that equal numbers of modules could be installed in each circumferential row. As shown in figure 4(a) the model 1 assembly consisted of type A fuel-injector modules. The arrangement of these modules was such that a corotational flow of air was generated by the additive flow exiting from the outer swirlers at the interface of the inner and outer rows. The model 2 assembly used type A fuel-injector modules in the outer row and type B modules in the inner row, as shown in figure 4(b). The type B modules had the swirler exit flows opposite to those of the type A modules. Thus, when both type A and type B modules were used (fig. 4(b)), no corotational flow was induced by the swirlers. Instead localized

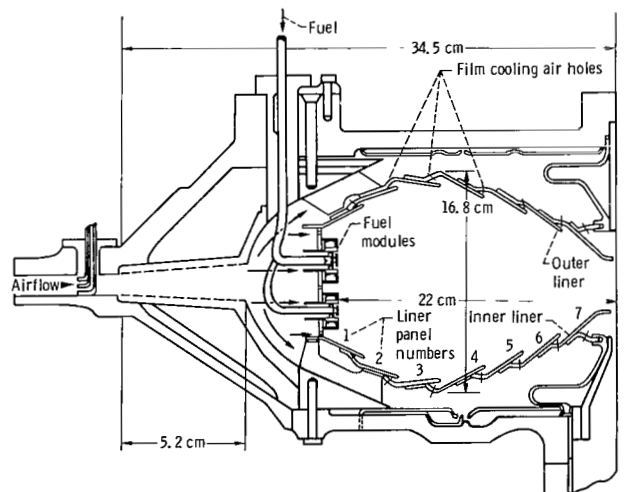
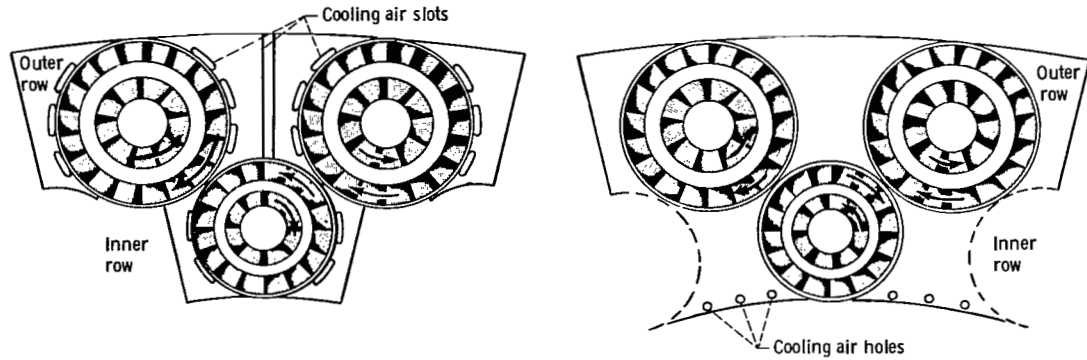
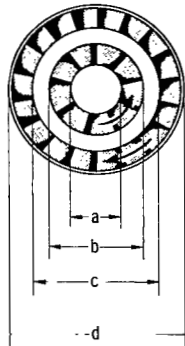

Figure 3. - Combustor test section with step-louver liner. (Not to scale.)



1.5	----- a -----	1.1
2.6	----- b -----	2.1
3.6	----- c -----	3.0
4.9	----- d -----	3.9



(a) Model 1 assembly comprised of type A fuel modules.



(b) Model 2 assembly comprised of type A modules for outer row and type B modules for inner row.

4.3	----- e -----	3.4
3.5	----- f -----	2.9
1.3	----- g -----	1.3
.8	----- h -----	.8

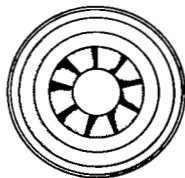

Type A

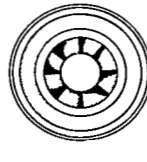

Type B

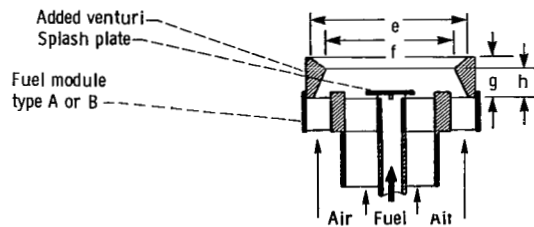

(c) Mixing venturis added to module discharge plane of model 2 assembly.

Figure 4. - Sketch of combustor fuel module assembly. (Dimensions are in centimeters.)

high shear regions were created by the opposing swirler flows from adjacent modules.

The modules used in the model 2 assembly with a short mixing venturi installed on the downstream side of each module are shown in figure 4(c). The purpose of the venturi was twofold: First, to reduce the flow area of the outer swirler and thus increase the combustor pressure loss; and second, to enhance mixing of the fuel and air in the wake of each module. Test results from the Experimental Clean Combustor program (refs. 2 and 3) and from in-house tests conducted in a simple tubular combustor (ref. 4) have shown that such venturis can cause reduced emissions and lower combustor liner temperatures.

Combustor Liners

Design.—The liners used for this investigation were designed to the specifications of table I. Although the facility used for the present tests had an upper pressure limit of 8 to 10 atmospheres, the 40-atmosphere specification was included so that the liners could be used in a future high-pressure combustor facility.

The mechanical design of the Lamilloy liner is shown schematically in figure 1. This liner and the step-louver liner were designed to have similar contours. The principle of Lamilloy is represented schematically in figure 5. Cooling air enters the liner through holes and passes between the metal layers through etched passageways. This air is eventually conducted through one metal layer to the next by holes. The process is repeated until the air leaves the liner on the combustion gas side. Cooling is achieved primarily by convection within the liner, though there may be some cooling because the exiting air provides a film barrier to heating. The design chosen

used three layers of material each 0.0508 centimeter thick. The selection of these dimensions was based on vendor experience in fabricating combustor liners for a variety of applications. A large enough passage size was selected to allow passage of foreign material in the combustion air through the liner. Considerable impurities are in the combustion air supply, but they are usually in the form of a very fine iron oxide powder that should easily pass through the liner without plugging the passages.

The heat transfer analysis was performed at the maximum operating condition, as shown in table I. The analysis assumed that the average gas temperature close to the fuel modules was 2300 K but that the temperature farther downstream was near stoichiometric, or 2650 K. Maximum hot-spot temperatures were also assumed to be the stoichiometric temperature. The designed combustor pressure loss and liner differential pressure were based on calculations and on data supplied from tests conducted with conventional film-cooled liners. Once the analysis had determined the required cooling flux and pressure loss distribution, the Lamilloy permeability could be determined. The permeability, expressed as discharge coefficients, for required flows is shown in figure 6. Figure 6 also shows the coefficient values of the three permeabilities selected and the liner length over which these values apply. The highest permeability was used in the exhaust transition region as this region requires the greatest cooling.

The material selection was based on the following factors:

- (1) High-temperature strength
- (2) High-temperature oxidation resistance
- (3) Buckling resistance
- (4) High modulus of elasticity
- (5) Ease of fabrication and repair

TABLE I. COMBUSTOR LINER DESIGN

REQUIREMENTS

Maximum operating condition.

Inlet air temperature, K.....	900
Inlet air pressure, atm.....	40
Liner exit average temperature, K.....	2500
System pressure loss differential, percent.....	10
Lamilloy liner maximum metal temperature, K.....	1310
Step-louver liner maximum metal temperature, K.....	1260
Desired lifetime at maximum operating conditions, hr.....	100
Allowable cooling airflow rate, percent (percent of total flow).....	18
Flow factor range, $W\sqrt{T/P}$, ^a	44-65

^a Where W is total airflow in kg/sec, T is nominal inlet air total temperature in K, and P is nominal inlet air total pressure in atm.

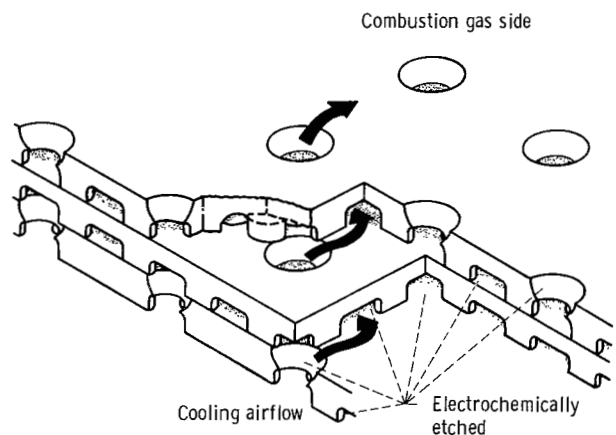

Figure 5. - Sketch of Lamilloy construction and airflow path.

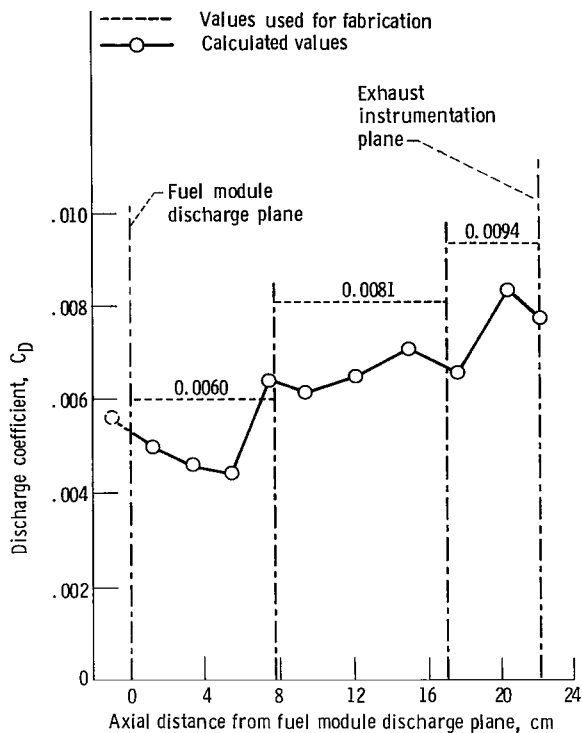

Figure 6. - Lamilloy permeability selection.

Of these factors high-temperature strength and oxidation resistance were judged to be of the greatest importance in this application. Hastelloy X, Haynes 188, and thoria-dispersed (TD) nickel-chromium materials were evaluated. Haynes 188 was selected for use as it has better high-temperature strength than Hastelloy X without the difficult fabrication and welding problems of TD nickel-chromium.

Detailed stress and buckling analyses were applied to the liner designs. Where appropriate a finite element stress analysis was used. The buckling analysis led to the conclusion that five stiffening rings were required on the outer liner, and these were added to the liner at the positions indicated by the analysis. The stiffening rings are shown in figure 1.

The estimated life of the Lamilloy liner was calculated by using the strain-life curves based on the work of Manson (ref. 5). Strain-life curves were developed for a variety of material properties and surface conditions. The results indicate that a liner life of 109 hours is achievable for reduced material properties and a notched surface. Increases in life were calculated by assuming smooth rather than notched material.

Reference 6 describes the first investigations with the Lamilloy liner. Temperature-indicating paint was used to determine metal temperatures. The tests indicated that the axial and circumferential welds

required to fabricate the Lamilloy panels were considerably hotter than the adjacent Lamilloy. Because of the hotter weld temperatures three thermocouples were installed on each liner in the welds, and additional tests were conducted. The thermocouple positions are shown in figure 7.

The film-cooled step-louver liner (shown in the test combustor in fig. 3) was designed to withstand the operating conditions shown in table I. The added protection furnished by a thermal barrier coating that was applied to the liner combustion gas side was not considered in the detailed thermal and stress analysis. This liner had undergone extensive testing to exhaust temperatures in excess of 2200 K with no apparent damage or deterioration. However, testing had been limited to pressures of 8 atmospheres, which was a facility limitation. Compared with conventional aircraft engine liners the metal of this liner was quite thick, being fabricated of 0.20-centimeter-thick Hastelloy X material. As with most combustors of this type there were no dilution air holes in the liner. All air except that required for liner cooling passed directly through the array of fuel modules. The conditions shown in table I are quite stringent, and the low availability of cooling air because of near-stoichiometric operation makes the liner design very critical.

Fabrication.—The Lamilloy liner is composed of a series of Lamilloy sheets welded together. The seams between adjacent sheets are arranged to be at an angle to the flow so that there is always film airflow across, rather than parallel to, the narrow weld joint. The liner panel portions, composed of Lamilloy of

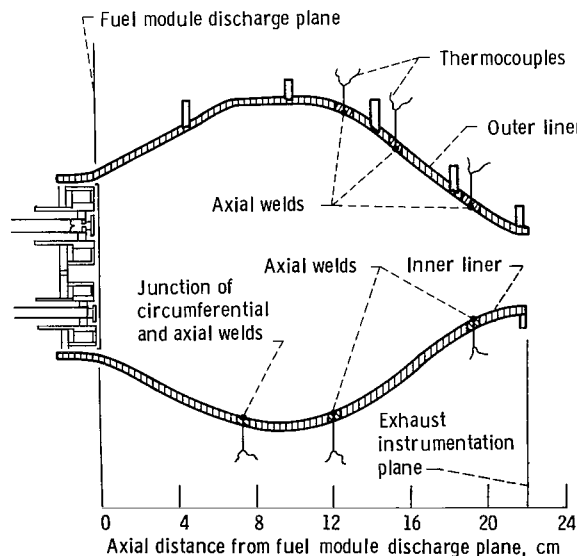

Figure 7. - Axial position of thermocouples installed on Lamilloy liner.

varying permeability, were hydroformed to the proper shape and then welded together to form the complete liner. Hydroforming was necessary, rather than spinning, because of the particular liner geometry chosen for this combustor. A less convoluted liner could probably be spun, which is a simpler fabrication procedure than hydroforming. The finished liners are shown in figure 8 (the inner liner in fig. 8(a) and the outer liner in fig. 8(b)). Stiffening rings can be clearly seen in figure 8(b).

Film cooling air calibration.—Before the combustion tests were begun, both the Lamilloy and the step-louver liner were film-airflow calibrated. This was done by installing both inner and outer liners on a flow stand and measuring the airflow rate through the liners at varying pressure drops across the liner. A sketch of the calibrating stand is shown

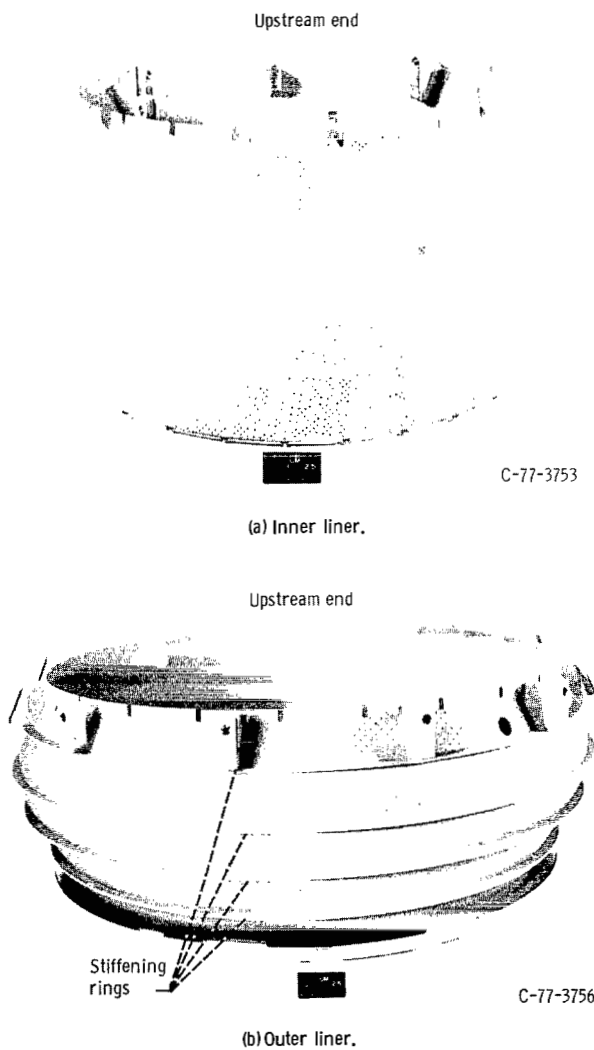

Figure 8. - Lamilloy liner with temperature-indicating paint.

in figure 9. The Lamilloy liner was calibrated as a unit. For the step-louver liner some of the individual louvers were calibrated one at a time by unmasking or untaping the various cooling hole rows sequentially. The flow curve for the Lamilloy liner is presented in figure 10(a), and the flow calibrations for the step-louver liner in figure 10(b). Table II gives the characteristics of the inner and outer step-louver liners. The table lists the number of holes, the hole diameter, the total flow area, and the calibrated value of the area of the unblocked film cooling air holes times the flow coefficient AC_d and C_d for some of the individual panels. The AC_d value for the entire Lamilloy liner is compared with values for the step-louver liner in table III.

Test Facility

The investigation was conducted in a closed-duct facility. The flow path and the arrangement of the major components of the combustion air system are shown in figure 11. The combustion air is heated to a maximum of 589 K in an outside preheater and is delivered to the cell through a 91.5-centimeter-diameter ASME orifice run. Upon reaching the test cell the air can be delivered to the test combustor or it can be first passed through heat exchangers having

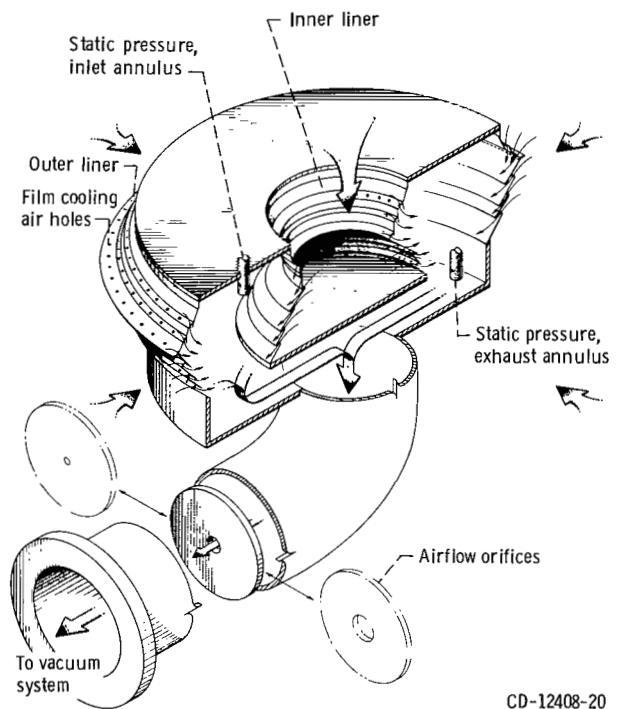

Figure 9. - Liner cooling airflow calibration fixture. Single or multiple rows of holes can be calibrated.

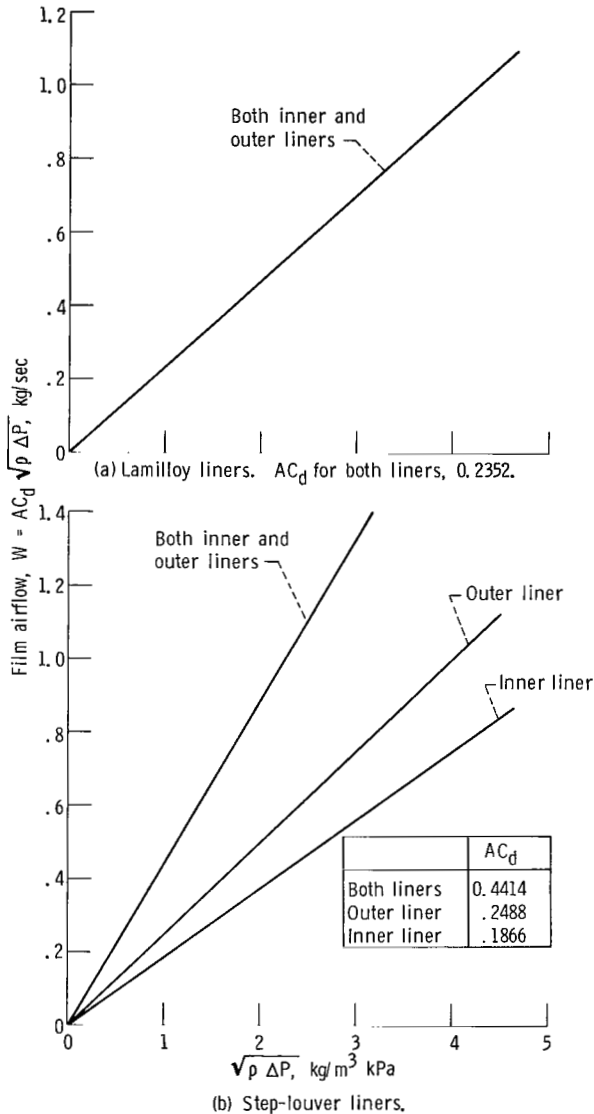

Figure 10. - Calibrated film airflow through combustor liners as a function of air density and pressure differential across liners.

the capacity to heat the air to 922 K. Fixed probes at the test combustor entrance measure the inlet temperature and pressure profiles. The combustor airflow rate and pressure are set with an inlet valve and an exhaust valve. Before the hot gas enters the exhaust valve, it is cooled to 355 K or less by a series of quench water sprays. Beyond the exhaust valve the gas flows into the central atmospheric or altitude exhaust system. A more complete description of the facility is given in reference 7.

Instrumentation

A cross-sectional sketch of the test rig, showing instrumentation planes and dimensions, is presented in figure 12. The combustor inlet air average temperature was determined from eight Chromel-Alumel thermocouples mounted at plane 2 (fig. 12). Figure 13(a) shows the position dimensions of these thermocouples, which were installed at centers of equal areas. The indicated thermocouple readings were taken as true values of total temperature. In figure 13(b) are shown the dimensions of the eight inlet total pressure rakes of four probes each, installed at centers of equal areas, and the dimensions of 16 wall static pressure taps, eight equally spaced around both the inner and outer walls. Inlet pressure instrumentation was mounted at plane 3 (fig. 12). Exhaust gas instrumentation was mounted at plane 4 (fig. 12). Dimensions are given in figure 13(c). There were eight fixed rakes each containing five total pressure probes and five platinum-plus-13-percent-rhodium/platinum as irated thermocouples for measuring total temperature. All were mounted at centers of equal areas. Static pressure was measured by four wedge static probes equally spaced around the annulus at area centers. Four gas sample rakes, each with three area-centered probes, were equally spaced around the circumference. The rakes were plumbed so that gas samples could be obtained from any individual rake or combinations of two, three, or four. The three probes of each rake were all tubed to a common manifold.

Four additional thermocouples were installed on both the inner and outer Lamilloy liners, giving a total of seven on each. Their axial positions are shown in figure 14. The arithmetic average temperature of the 14 thermocouples was considered the liner metal average temperature.

Chromel-Alumel thermocouples were installed on the step-louver liners to indicate the hot-gas-side surface temperature of the metal, on which a thermal barrier coating had been applied. Eight thermocouples were equally spaced circumferentially around the number 4 panel (fig. 3), straddling the centerlines. One thermocouple each was installed at 0° and 180° on panels 1 and 7. The outer liner had one additional thermocouple at 180° on panel 3. The step-louver liner average metal temperature was determined from the arithmetic average of the 25 thermocouples.

Procedure

The operating conditions for the evaluation of the combustor liners are listed in table IV. Most of the tests were conducted at a nominal test pressure of 5

TABLE II.—FILM-AIRFLOW CALIBRATION OF STEP-LOUVER LINERS

(a) Inner liner

Panel	Number of film holes per panel	Diameter of film holes, cm	Total film hole area per panel, cm ²	Calibration value of AC_d^a	Calibration value of flow coefficient C_d
1 (upstream)	142	0.282	8.865	0.0316	0.00357
2	132	.295	9.000	-----	-----
3	132	.318	10.451	.0375	.00359
4	132	.295	9.000	.0319	.00354
5	142	.239	6.358	-----	-----
6	162	.226	6.502	-----	-----
7 (downstream)	178	.170	4.049	-----	-----
All panel holes unblocked			54.225 cm ² /liner	0.1866	0.00344

(b) Outer liner

1 (upstream)	220	0.249	10.706	0.0385	0.00360
2	252	.239	11.283	.0444	.00394
3	258	.253	12.943	.0479	.00370
4	228	.254	11.553	.0419	.00363
5	220	.218	8.245	.0308	.00374
6	208	.226	8.348	.0311	.00373
7 (downstream)	196	.170	4.458	.0176	.00395
All panel holes unblocked			67.536 cm ² /liner	0.2488	0.00368

^a $W = AC_d \sqrt{\rho \Delta P}$, where W is film cooling airflow in kg/sec; A is area of unblocked film cooling air holes in cm²; C_d is flow coefficient; ρ is density of film cooling air entering liner in kg/m³, and ΔP is pressure differential across liner in kPa.

TABLE III.—COMPARISON OF CALIBRATION FILM-AIRFLOW VALUES OF AC_d FOR LAMILLOY AND STEP-LOUVER LINERS

	Lamilloy liner	Step-louver liner
	Film airflow values of AC_d^a	
Inner liner	-----	0.1866
Outer liner	-----	.2488
Inner and outer liners	0.2352	.4414

^a $W = AC_d \sqrt{\rho \Delta P}$ where W is film cooling airflow in kg/sec; A is area of unblocked film cooling air holes in cm²; C_d is flow coefficient; ρ is density of film cooling air entering liner in kg/m³; and ΔP is pressure differential across liner in kPa.

atmospheres with an inlet air temperature of 894 K. The combustor was operated over a range of fuel-air ratios. This range was limited to a maximum fuel-air ratio value of about 0.021 to 0.023 when the thermocouple rakes were installed in the exhaust. To

operate at higher fuel-air ratios, it was necessary to remove the thermocouple rakes and rely entirely on gas analysis measurements to determine combustor performance.

The test operational procedures were as follows: The inlet air temperature was raised to the desired level, and the inlet pressure and airflow were adjusted to the desired values for ignition. Once the combustor was lit, the parameters of air pressure, inlet air temperature, and airflow rate were maintained as close as possible to the values shown in table IV. Data were recorded at each fuel-air ratio setting, with careful attention paid to the liner temperatures. If the liner temperatures were not considered to be dangerously high, the fuel-air ratio would be increased and data recorded again. This procedure was followed for the tests with each liner. Smoke numbers were determined as follows: The absolute reflectivity of the stain on Whatman number 4 filter paper, obtained from the exhaust gas sample, was measured with the Welch Densichron using a black background. The Densichron was calibrated with a Welch Gray scale. The smoke index was determined from the following equation:

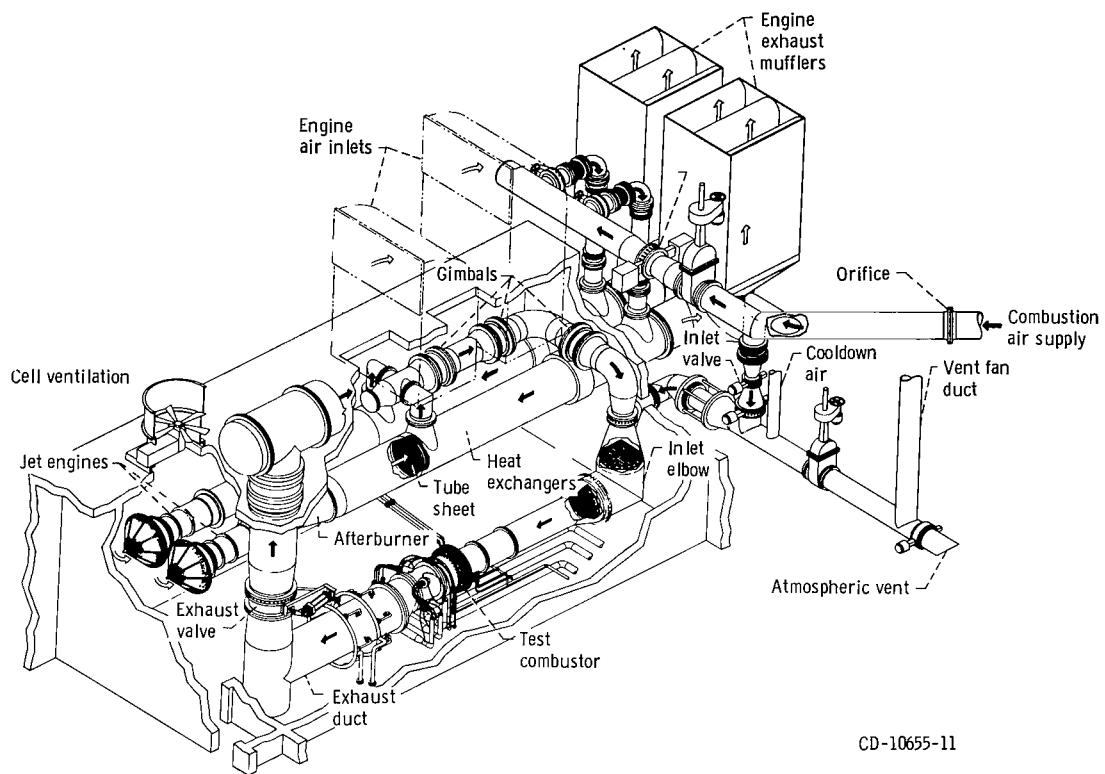

CD-10655-11

Figure 11. - Combustor test facility showing flowpaths and equipment arrangement.

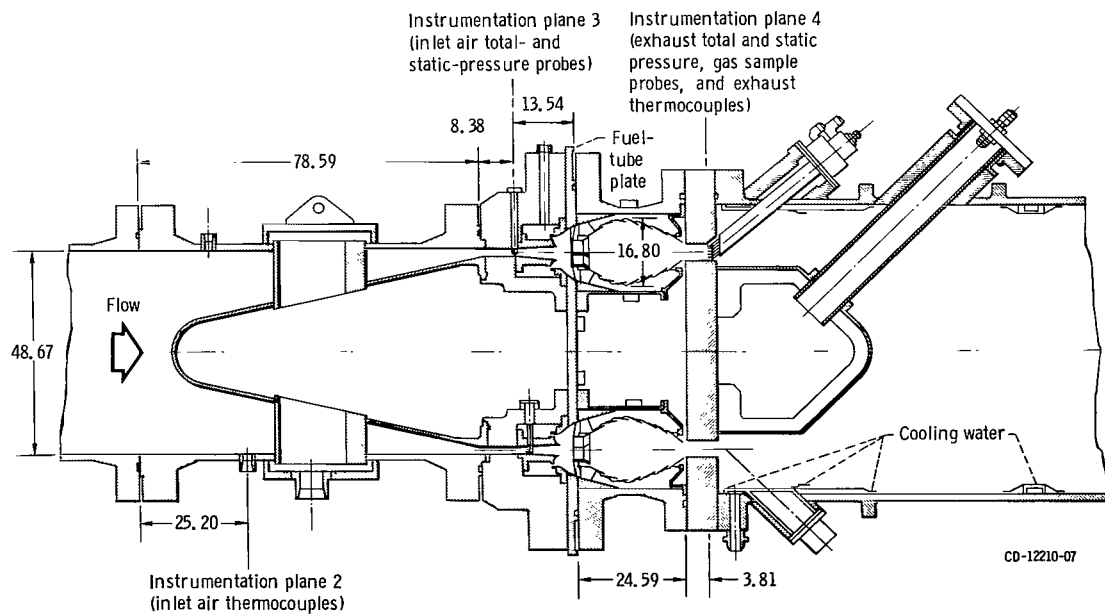

CD-12210-07

Figure 12. - Schematic cross section of combustion test rig showing combustor liner test section. (Dimensions are in centimeters.)

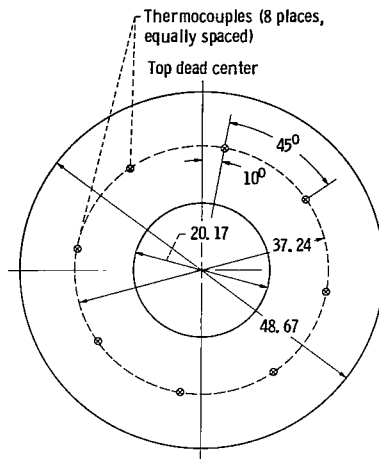

(a) Inlet air Chromel-Alumel thermocouples (fig. 12, plane 2).

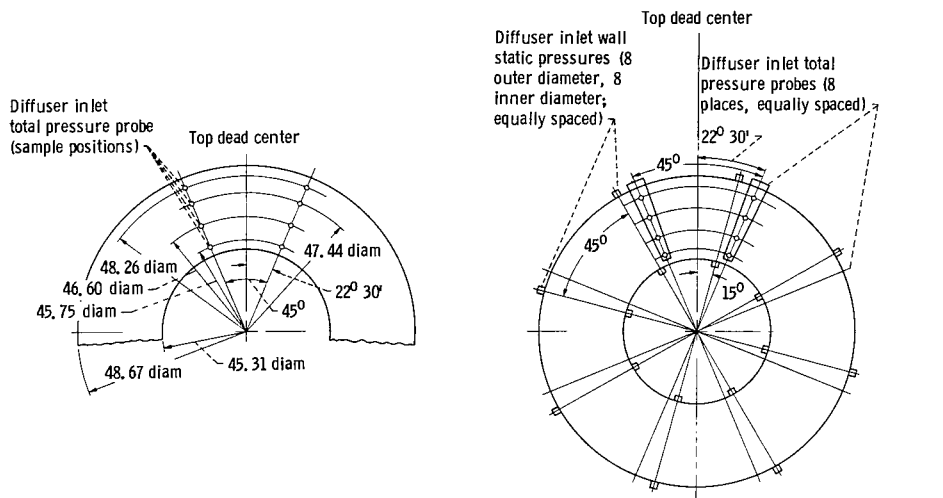

(b) Diffuser inlet air total and static pressure instrumentation (fig. 12, plane 3)

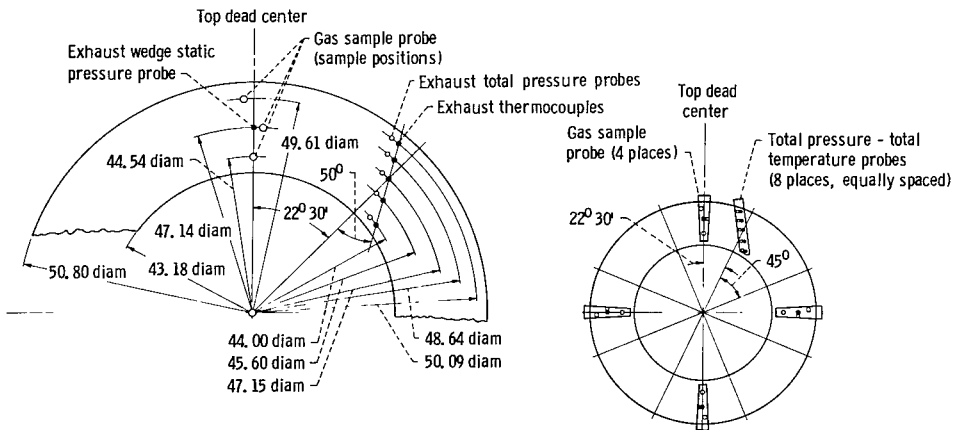

(c) Exhaust gas total and static pressure probes, exhaust gas sample probes, and exhaust gas thermocouples (fig. 12, plane 4).
 Figure 13. - Combustor test instrumentation. (All views looking downstream. Not to scale. Dimensions are in centimeters.)

Results and Discussion

Liner Metal Temperature

The results of the first tests with the Lamilloy liner are presented in reference 6 and are compared with step-louver liner data in this section.

The first Lamilloy test was conducted at an inlet air pressure of 7.9 atmospheres, an inlet air temperature of 894 K, and an average combustor exhaust gas temperature of 1700 K. The test time was only about 10 minutes, long enough to ensure that the paint would undergo the appropriate color changes. When examined after this test, both the inner and outer liners were uniformly the same color, with the exception of some slight color differential in narrow regions at each weld joint. The color change indicated that the hottest portions of the liner were only about 180 kelvins above the inlet air temperature. The remainder of the liner showed only the uniform color indicative of very low thermal gradients. This test was not severe enough to pinpoint areas, other than liner weld joints, where thermocouples should be located. The liner was cleaned and repainted with temperature-indicating paint preparatory for testing at higher combustor exit temperatures. Three thermocouples were installed on both the inner and outer liners. These thermocouples were placed in liner weld joints between Lamilloy panels as shown in figure 7.

The operating conditions for the second test were an inlet air pressure of 7.9 atmospheres and an inlet air temperature of 894 K; the combustor average exhaust temperature was varied upward from 1700 K to 2215 K in several steps. Substantial color changes were obtained this time and are shown in figure 15. Figure 16 is a plot of the readings of the inner and outer liner thermocouples at the two combustor exhaust gas temperatures. Two test points were obtained: the first at an average exhaust gas temperature of 1719 K to confirm with thermocouples the temperatures indicated by paint in the previous test, and second at an average exhaust gas temperature of 2215 K to force pronounced color changes in the paint. The liner temperatures at the lower combustor exhaust gas temperature were generally in agreement with those temperatures indicated by the paint. That is, the weld areas were at least 180 kelvins hotter than the inlet air temperature. At the higher combustor exhaust gas temperature the inner liner hot spot (fig. 16(a)) was about 285 kelvins above the inlet air temperature, or a metal temperature of 1180 K. The results obtained with the outer liner are shown in figure 16(b). Two thermocouples on this liner failed during the higher-

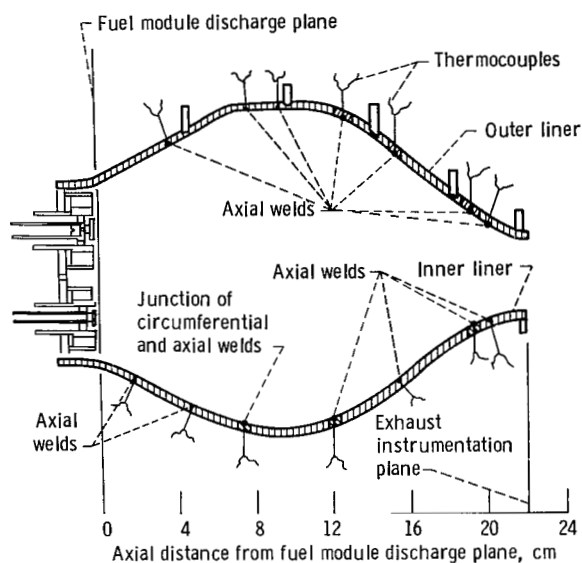

Figure 14. - Axial position of thermocouples installed on Lamilloy liner. (Seven thermocouples on each liner.)

TABLE IV.—NOMINAL TEST CONDITIONS

[Inlet total temperature, 894 K; diffuser inlet Mach number, 0.419; liner reference Mach number, 0.038; film cooling airflow for model 2 combustor, 15.4 and 9.2 percent of total airflow for step-louver and Lamilloy liner, respectively; film cooling airflow for model 2 combustor with venturis, 13.7 percent of total airflow for Lamilloy liner.]

Inlet total pressure, MPa	Inlet airflow, kg/sec
0.505	10.81
.649	13.90
.723	15.44
.794	16.99

$$100 \times \left[1 - \frac{\% \text{ absolute reflectivity of sample}}{\% \text{ absolute reflectivity of clean paper}} \right]$$

Smoke numbers were then calculated by the procedure given in reference 1.

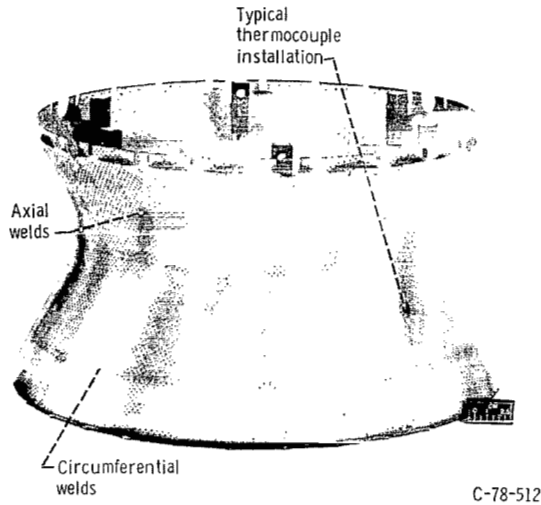

(a) Inner liner.

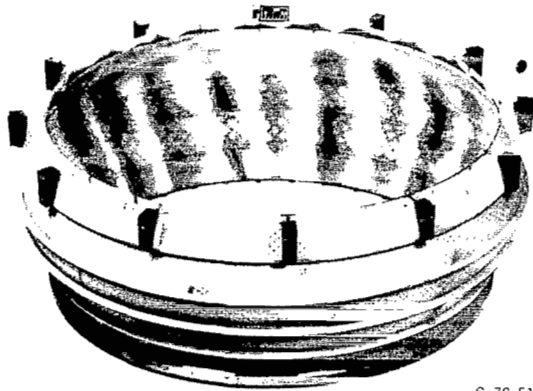

(b) Outer liner.

Figure 15. - Lamilloy liner with temperature-indicating paint after test to 2215 K average exhaust gas temperature.

combustor-exhaust-gas-temperature test. The outer liner tended to operate slightly hotter than the inner liner, but as before the hottest region was the combustor exit portion of the liner. The maximum indicated temperature was 380 kelvins above the inlet air temperature, or a metal temperature of 1272 K.

Liner metal temperatures from preliminary tests with the Lamilloy liner of reference 6 were compared with data for the step-louver liner, both using the model 1 fuel modules (fig. 4(a)). The data, presented in figure 17, were obtained over a range of fuel-air ratios and test pressures. The data presented are the average of all the liner thermocouples (both inner and outer liners) minus the inlet air temperature. Also shown is the maximum liner temperature that

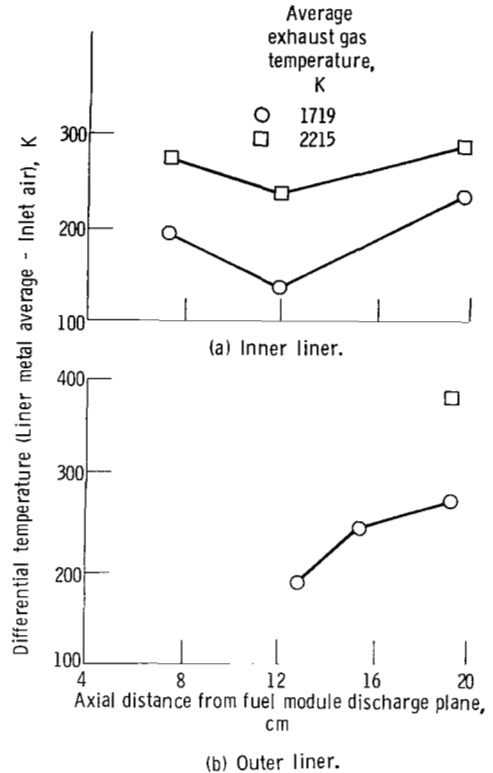

Figure 16. - Lamilloy liner temperatures, as indicated by thermocouples, obtained during tests at two combustor exhaust gas temperatures. Nominal inlet air total temperature, 895 K; nominal inlet air total pressure, 7.9 atm. (From ref. 6.)

was measured. These data were obtained at pressures from 5 to 8 atmospheres and do not indicate any effect of pressure over this range. The Lamilloy liner metal temperatures were somewhat higher than the temperatures obtained with the step-louver liner.

For an 0.043 fuel-air ratio the average metal temperatures for the Lamilloy and step-louver liners were 295 and 265 kelvins, respectively, above inlet air temperature, or actual average values of 1189 and 1159 K. The step-louver liner average metal temperature was only about 30 kelvins lower than that obtained with the Lamilloy liner even though the film cooling airflow rate was about 1.8 times the Lamilloy value (fig. 10 and table III).

The combustion exhaust gas temperature, determined from gas analysis data, is shown in figure 18 as a function of fuel-air ratio. For a fuel-air ratio of 0.043 the combustion exhaust gas temperature was 2215 K for the particular operating conditions. The Lamilloy and step-louver liner metal average temperatures of 1189 and 1159 K, respectively, were

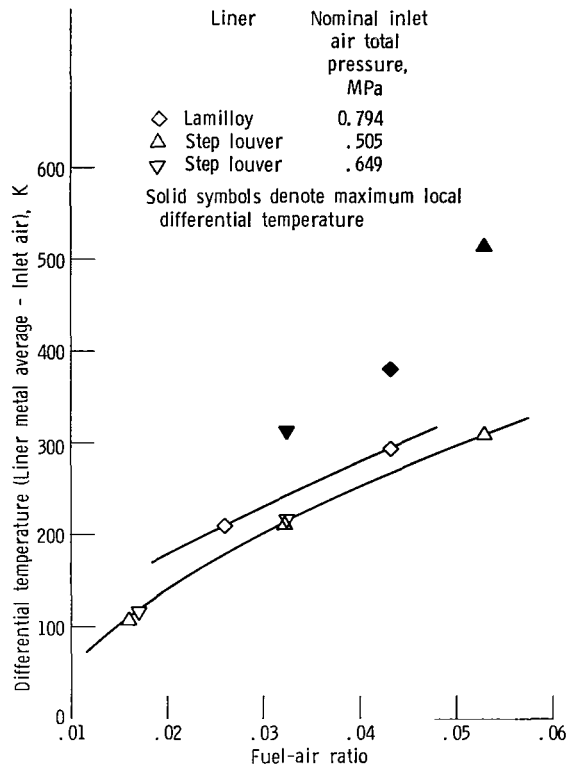

Figure 17. - Lamilloy liner and step-louver liner differential metal temperatures as a function of fuel-air ratio - for fuel module assembly model 1. Nominal inlet air total temperature, 894 K.

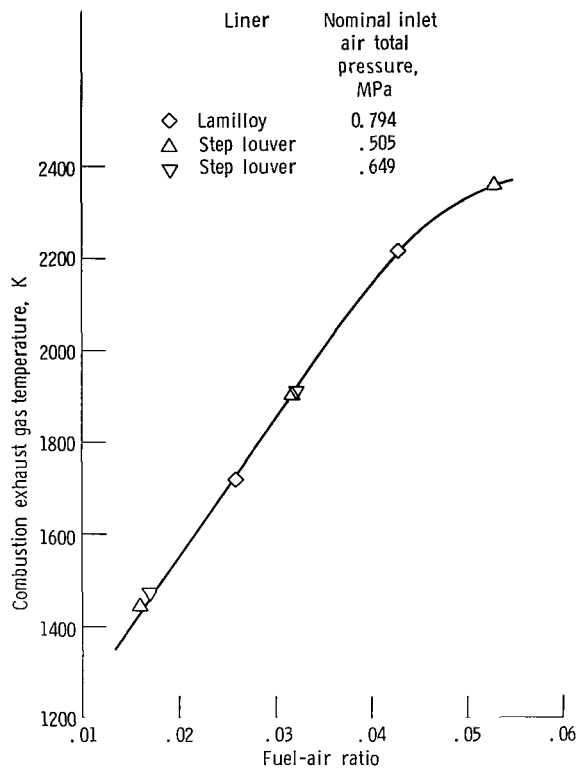

Figure 18. - Combustor exhaust gas temperature as a function of fuel-air ratio, determined by gas analysis, obtained during tests with both Lamilloy and step-louver liners - for fuel module assembly model 1. Nominal inlet air total temperature, 894 K.

obtained with a combustion exhaust gas temperature of 2215 K.

As a result of these tests two serious problems were discovered with the Lamilloy liner. First, the pattern of hot streaks shown by the temperature-indicating paint was aligned with the angled welds that joined the pieces of Lamilloy together to form a continuous hoop. These angled axial welds and the hot streaks can be seen in figure 15. Second, the Lamilloy liner cooling airflow was below the design value because of a change in the overall combustor pressure loss characteristic. This change occurred when the more open counterswirl fuel-injector module assemblies, models 1 and 2 (figs. 4(a) and (b)), were substituted for a less durable design that had higher airflow blockage.

Hot-streak problem.—The alignment of the hot streaks with the angled axial welds was considered to be very serious. The only cooling of these welds was by conduction and a washing over of the film air formed by cooling flows exiting the Lamilloy just upstream of each weld. Hot streaks aligned with the insufficiently cooled welds could result in damage. The hot streaks were observed to be swirling, and this

was believed to be caused by the arrangement of the outer air swirler of the type A fuel-injector modules. As shown in figure 4(a) these swirlers reinforce each other to induce a coswirl flow. The model 2 assembly was constructed to eliminate this problem. Type B fuel-injector modules were installed on the inner row as shown in figure 4(b) to prevent the formation of any net swirl in the airflow pattern.

The model 2 modules were tested over a limited fuel-air ratio range. Figure 19 compares average liner metal temperatures obtained with model 2 for the Lamilloy and step-louver liners. Though data were obtained only to a fuel-air ratio of 0.0235, the trend as shown in figure 19 is clearly indicated. Average metal temperatures of the Lamilloy liner were lower than those of the step-louver liner, and the maximum metal temperature as measured in one of the axial welds was also lower than that obtained with model 1 assembly. Thus the arrangement of fuel-injector modules comprising model 2 was successful in minimizing the effect of any hot streaks on the axial welds in the Lamilloy liner.

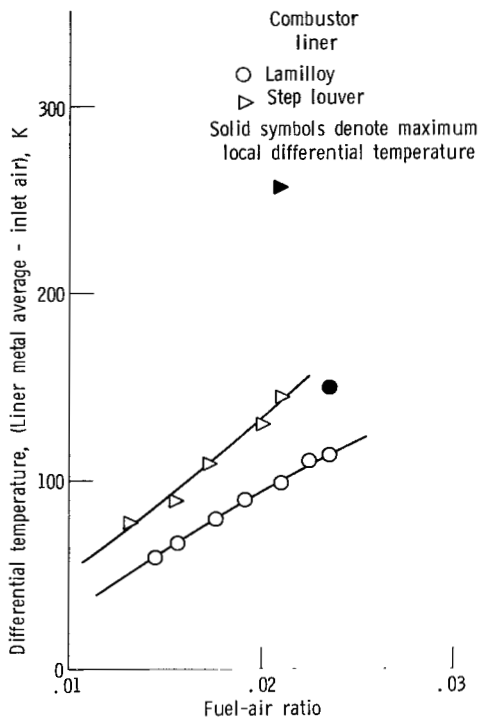

Figure 19. - Lamilloy liner and step-louver liner differential metal temperatures as a function of fuel-air ratio - for fuel module assembly model 2. Nominal inlet air total temperature, 894 K; nominal inlet air total pressure, 0.723 MPa.

Lamilloy liner cooling flow.—A plot of combustor liner isothermal pressure loss as a function of diffuser inlet Mach number is shown in figure 20 of the Lamilloy and step-louver liners with the model 2 fuel-injector module assembly. Also included are the pressure loss values used for design of the Lamilloy liner. Liner pressure loss is calculated as follows:

$$\frac{(\text{Liner annulus av. st. press.}) - (\text{Ex. av. tot. press.})}{(\text{Diffuser inlet av. tot. press.})}$$

The Lamilloy liner operated at a combustor pressure loss considerably less than design and hence was not flowing the required amount of cooling air. Also, by design, the film cooling airflow for the step-louver liner was greater than that for the Lamilloy liner at any particular combustor pressure loss.

To determine if there is or is not an advantage to using combustor liners fabricated from Lamilloy, the pressure loss values had to be adjusted to be closer to the design values. To increase the pressure loss across the Lamilloy liner, it was necessary to increase the flow blockage of the fuel-injector module assembly.

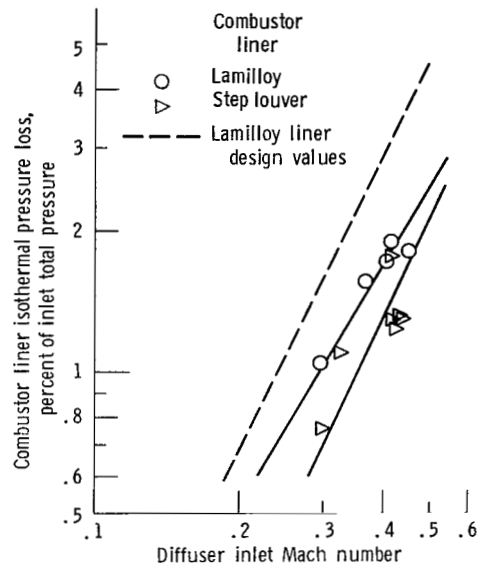

Figure 20. - Isothermal (nonburning) liner pressure loss as a function of diffuser inlet Mach number - for fuel module assembly model 2. Variable inlet air pressure, temperature, and flow.

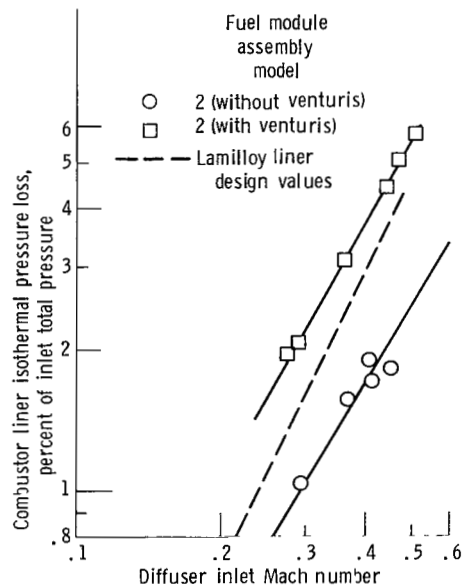

Figure 21. - Pressure loss across Lamilloy liner as a function of diffuser inlet Mach number - for fuel module assembly model 2 with and without venturis. Variable inlet air pressure, temperature, and flow.

This was done by adding mixing venturis to the outer swirlers of each module of the model 2 assembly, as shown in figure 4(c). These venturis reduced the flow area of the outer swirler slightly and therefore increased the pressure loss across the fuel-injector assembly. The venturis also served to direct the airflow from the outer swirler inward and should result in an improved mixing of the fuel and air streams. The pressure losses across the Lamilloy liner with the model 2 modules with and without the mixing venturis are compared in figure 21. The installation of the mixing venturis did increase the pressure loss substantially, and a pressure loss slightly higher than the original design value was achieved. The increased pressure differential across the liners resulted in an cooling airflow value of 13.6 percent of the total combustion airflow, as compared with 9.2 percent of total airflow at the lower differential pressure.

The Lamilloy liner temperatures for model 2 modules with and without mixing venturis are compared in figure 22. With the mixing venturis installed, tests were conducted to an overall fuel-air ratio of about 0.064 to 0.065 without the liner metal average or the maximum local metal temperature limiting the maximum fuel-air ratio. As shown in figure 22 the average liner temperatures with the venturis were lower than when no venturis were installed. This is due primarily to the increased cooling airflow rate through the Lamilloy liner. The exhaust gas temperature at the 0.065 fuel-air condition, determined by gas analysis, was about 2430 K. At this condition the average liner metal and maximum local temperature differentials above the

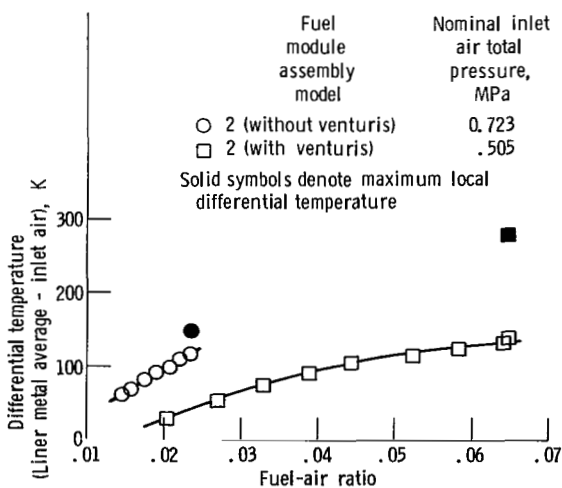

Figure 22. - Lamilloy liner differential metal temperatures as a function of fuel-air ratio - for fuel module assembly model 2 with and without mixing venturis. Nominal inlet air total temperature, 894 K.

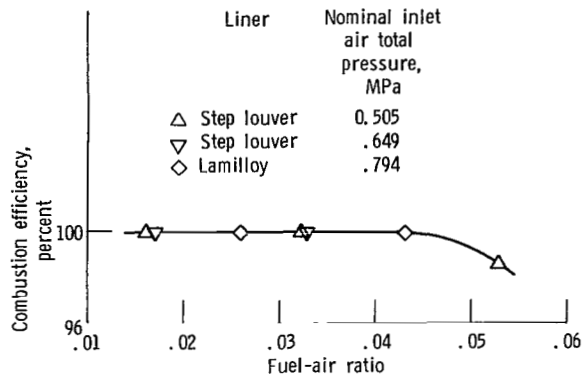

Figure 23. - Lamilloy and step-louver liner combustion efficiency as a function of fuel-air ratio - for fuel module assembly model 1. Nominal inlet air total temperature, 894 K.

inlet air temperature were 140 and 280 kelvins, respectively, or metal temperatures of 1034 and 1174 K.

Combustion Efficiency and Pattern Factor

Effect of liner type and fuel module model.— Comparisons of the combustion efficiency values obtained with the Lamilloy and step-louver liners with the model 1 fuel module assembly are shown as a function of fuel-air ratio in figure 23. Combustion efficiency was determined from gas analysis data. As shown, there is no apparent difference in efficiency values, which were near 100 percent, over a fuel-air ratio range of 0.016 to 0.043. For these tests inlet pressure was varied from 0.505 MPa to 0.794 MPa; the inlet temperature nominal value was 894 K.

Combustion efficiency and pattern factor data are presented in figure 24 as a function of fuel-air ratio for the Lamilloy and step-louver liners with the model 2 fuel module assembly. For the range of fuel-air ratios tested combustion efficiency was nearly 100 percent for both liners (fig. 24(a)). Figure 24(b) presents pattern factor data. For a fuel-air ratio range of 0.013 to 0.016 there was an appreciable difference in pattern factors between liners; the values from the step-louver liner were higher. The pattern factor values varied from about 0.21 to 0.31. Pattern factor values were calculated as follows:

$$\text{Pattern Factor} = \frac{(\text{Ex. max. local temp.}) - (\text{Av. ex. temp.})}{(\text{Av. ex. temp.}) - (\text{Av. combustion inlet temp.})}$$

Pattern factor data were calculated from data obtained with the exhaust thermocouple rakes (fig. 12, plane 4). Because of the exhaust gas

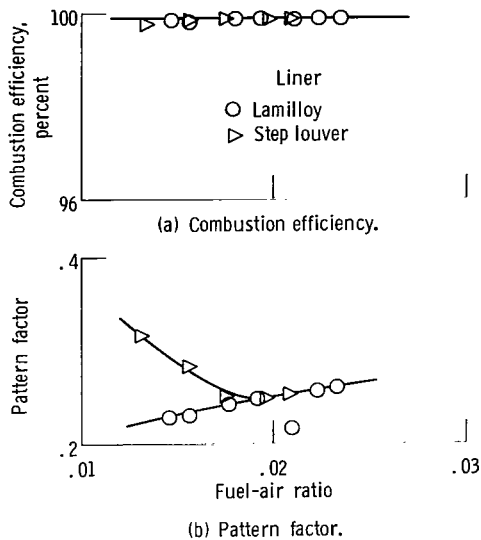

Figure 24. - Lamilloly and step-louver liner combustion performance parameters as a function of fuel-air ratio - for fuel module assembly model 2. Nominal inlet air total temperature, 894 K; nominal inlet air total pressure, 0.723 MPa.

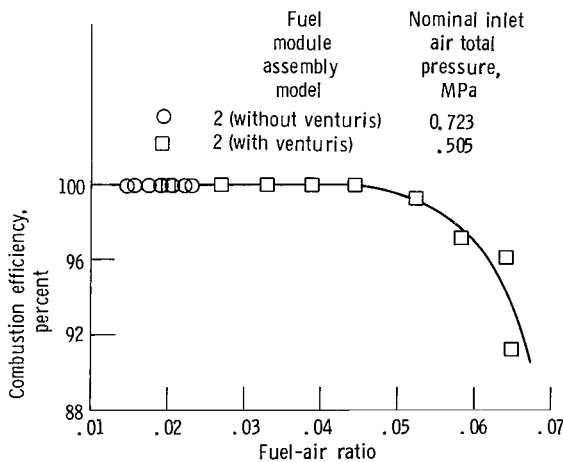

Figure 25. - Lamilloly liner combustion efficiencies as a function of fuel-air ratio - for fuel module assembly model 2 with and without venturis. Nominal inlet air total temperature, 894 K.

temperature limitation on the thermocouple rakes, they were removed from the test rig during operation at fuel-air ratios above about 0.021 to 0.023. Therefore there are no pattern factor data presented at the higher fuel-air ratios.

Results of investigations with the Lamilloly liner and the model 2 module assembly with and without

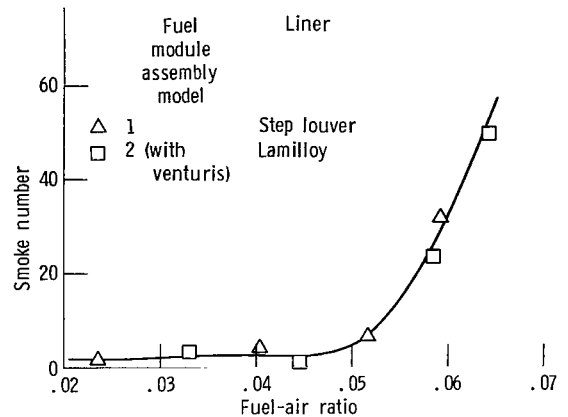

Figure 26. - Comparison of smoke numbers obtained with step-louver liner and fuel module assembly model 1 and those obtained with Lamilloly liners and fuel module assembly model 2 with mixing venturis. Nominal inlet air total pressure, 0.505 MPa.

the mixing venturis are shown in figure 25. The model 2 modules with venturis, permitted operation to a fuel-air ratio of about 0.065 without exceeding liner maximum metal temperature limits (table I). The combustion efficiency for model 2 both with and without venturis was nearly 100 percent for a range of fuel-air ratios of 0.015 to 0.045. As the fuel-air ratio was increased to 0.065, the combustion efficiency decreased to about 91 percent.

Smoke Density

Smoke density data are given in figure 26 as a function of fuel-air ratio. Data include test results using the step-louver liner and the model 1 module assembly and test results using the Lamilloly liner and the fuel model 2 assembly with venturis. The nominal inlet conditions were 0.505-MPa pressure and 894 K temperature. The smoke numbers obtained from the tests with both configurations were similar. The numbers were below 5 for fuel-air ratios of 0.024 to 0.044 and increased to about 25 (visible smoke region) as the fuel-air ratio was increased to 0.058.

Summary of Results

Comparison of performance was made between data obtained with Lamilloly liners and data obtained with step-louver liners with different fuel module models. Data were obtained at pressures to 0.794 MPa, an inlet air temperature of 894 K, and exhaust gas temperatures to 2430 K.

The following results were obtained:

1. For the Lamilloy liner operated with a nominal inlet air temperature of 894 K and an exhaust gas average temperature of 1700 K, temperature-indicating paint on the hot-gas side of the Lamilloy liners was of uniform color, except at the Lamilloy panel welds. This indicates minimum thermal gradients throughout the liners. The paint color on the welds indicated a temperature about 180 kelvins above the inlet air temperature (or a 1074 K metal temperature).

Operation of a step-louver liner with a thermal barrier coating, at similar operating conditions, showed metal temperatures (from thermocouples) somewhat lower than those obtained with the Lamilloy liner; however, the design cooling airflow for the step-louver liner was about 1.8 times the cooling flow for the Lamilloy liner.

2. For the Lamilloy liner operated with a nominal inlet air temperature of 894 K and an exhaust gas average temperature of 2215 K, substantial color changes and indications of streaking were obtained with the temperature-indicating paint. Inner liner temperatures were 285 kelvins above the inlet air temperature, and outer liner temperatures were about 380 kelvins above the inlet air temperature. These represented liner metal temperatures of 1179 and 1274 K, respectively. The Lamilloy liner cooling airflow was about 9.2 percent of the total combustion airflow.

The step-louver liner metal temperatures, at similar operating conditions, were 300 kelvins and 460 kelvins above the inlet air temperature, for the inner and outer liners, respectively. The cooling airflow was 15.4 percent of the total combustion airflow.

3. A change in the fuel modules used with the Lamilloy liner was made to decrease the hot streaks indicated by the paint. Another change in the modules was made to increase the cooling air pressure differential across the liner and thus to increase the cooling airflow rate. With these changes to the fuel modules the 894 K inlet air temperature, and the 2430 K exhaust gas average temperature, an average liner metal temperature of 140 kelvins above

the inlet air temperature was obtained, with a local maximum of 280 kelvins above the inlet air temperature.

In addition to increasing the Lamilloy liner cooling airflow from 9.2 to 13.7 percent, the new fuel modules probably improved the mixing of the fuel and air streams, which would tend to decrease streaking.

4. Comparable smoke density data were obtained with both the Lamilloy and step-louver liners. The smoke numbers were below 5 for a fuel-air ratio range of 0.024 to 0.044 and then increased to about 25 as the fuel-air ratio increased to 0.058.

Lewis Research Center
National Aeronautics and Space Administration
Cleveland, Ohio, September 5, 1980

References

1. Environmental Protection Agency: Control of Air Pollution for Aircraft Engines—Emission Standards and Test Procedures for Aircraft. Fed. Regist., vol. 38, no. 136, July 17, 1973, pp. 19088-19103.
2. Gleason, C. C.; Rogers, D. W.; and Bahr, D. W.: Experimental Clean Combustor Program, Phase II. (R76AEG422, General Electric Co.; NASA Contract NAS3-18551.) NASA CR-134971, 1976.
3. Gleason, C. C.; and Bahr, D. W.: The Experimental Clean Combustor Program, Phase III. (R79AEG410, General Electric Co.; NASA Contract NAS3-19736.) NASA CR-135384, 1978.
4. Ercegovic, David B.: Effect of Swirler-Mounted Mixing Venturi on Emissions of Flame-Tube Combustor Using Jet A Fuel. NASA TP-1393, 1979.
5. Manson, S. S.: Fatigue, A Complex Subject—Some Simple Approximations, Exp. Mech., vol. 5, no.7, July 1965, pp. 193-226.
6. Wear, Jerrold D.; Trout, Arthur M.; Smith, John M.; and Jones, Robert E.: Design and Preliminary Results of a Semitranspiration Cooled (Lamilloy) Liner for a High-Pressure High-Temperature Combustor. NASA TM-78874, 1978.
7. Adam, Paul W.; and Norris, James W.: Advanced Jet Engine Combustor Test Facility. NASA TN D-6030, 1970.

1. Report No. NASA TP -1806	2. Government Accession No.	3. Recipient's Catalog No.
4. Title and Subtitle PERFORMANCE OF SEMI-TRANSPARATION-COOLED LINER IN HIGH-TEMPERATURE-RISE COMBUSTOR	5. Report Date March 1981	6. Performing Organization Code 505-32-32
7. Author(s) Jerrold D. Wear, Arthur M. Trout, and John M. Smith	8. Performing Organization Report No. E-494	10. Work Unit No.
9. Performing Organization Name and Address National Aeronautics and Space Administration Lewis Research Center Cleveland, Ohio 44135	11. Contract or Grant No.	13. Type of Report and Period Covered Technical Paper
12. Sponsoring Agency Name and Address National Aeronautics and Space Administration Washington, D.C. 20546	14. Sponsoring Agency Code	
15. Supplementary Notes		
16. Abstract <p>A combustor liner fabricated from Lamilloy was tested at inlet air pressures to 8 atmospheres, an inlet air temperature of 894 K, and exhaust gas temperatures to 2430 K. Results obtained with the Lamilloy liner are compared with results obtained with a conventionally designed, film-cooled step-louver liner. Operation of the Lamilloy liner with counterrotating swirl combustor fuel modules with mixing venturis was possible to a fuel-air ratio of 0.065 without obtaining excessive liner metal temperatures. At the 0.065 fuel-air condition the average liner metal temperature was 140 kelvins and the maximum local temperature 280 kelvins above the inlet air temperature. Combustion efficiency, pattern factor, and smoke data are included.</p>		
17. Key Words (Suggested by Author(s)) Combustors; Combustion efficiency; Liner temperatures; Fuel injection; Near-stoichiometric combustion	18. Distribution Statement Unclassified - unlimited STAR Category 07	
19. Security Classif. (of this report) Unclassified	20. Security Classif. (of this page) Unclassified	21. No. of Pages 19
		22. Price* A02

* For sale by the National Technical Information Service, Springfield, Virginia 22161

NASA-Langley, 1981

National Aeronautics and
Space Administration

SPECIAL FOURTH CLASS MAIL
BOOK

Postage and Fees Paid
National Aeronautics and
Space Administration
NASA-451



Washington, D.C.
20546

Official Business

Penalty for Private Use \$300

10 1 1U,A, 030281 S00903DS
DEPT OF THE AIR FORCE
AF WEAPONS LABORATORY
ATTN: TECHNICAL LIBRARY (SUL)
KIRTLAND AFB NM 87117

NASA

POSTMASTER: If Undeliverable (Section 158
Postal Manual) Do Not Return
