

N O T I C E

THIS DOCUMENT HAS BEEN REPRODUCED FROM
MICROFICHE. ALTHOUGH IT IS RECOGNIZED THAT
CERTAIN PORTIONS ARE ILLEGIBLE, IT IS BEING RELEASED
IN THE INTEREST OF MAKING AVAILABLE AS MUCH
INFORMATION AS POSSIBLE

Master

DOE/ER-0095
Dist. Category UC-20e

Environmental Assessment for the Satellite Power System (SPS): Studies of Honey Bees Exposed to 2.45 GHz Continuous-Wave Electromagnetic Energy

December 1980

Prepared for:
U.S. Department of Energy
Office of Energy Research
Solar Power Satellite Projects Division
Washington, D.C. 20585

Prepared by:
N.E. Gary and B.B. Westerdahl
University of California
For:
Argonne National Laboratory
Argonne, IL 60439
Under Contract No. 31-109-38-5448

DOE/NASA
Satellite Power System
Concept Development
and
Evaluation Program

DISCLAIMER

This report was prepared for the U.S. Department of Energy under contract number 31-109-38-5448. The U.S. Government is authorized to reproduce and distribute reprints for government purposes not withstanding any copyright notation that may appear hereon. This report is the property of the U.S. Department of Energy and is loaned to your organization; it and its contents are not to be distributed outside your organization.

"Page missing from available version"

FOREWORD

This report summarizes all research completed to date on the exposure of honey bees, Apis mellifera L., to 2.45 GHz CW microwaves. Each section consists of individual projects that are prepared for submission to various scientific journals for publication and therefore represent the format of each respective journal.

"Page missing from available version"

CONTENTS

GLOSSARY	x
ABSTRACT	1
SUMMARY	2
INTRODUCTION	3
1 A SYSTEM FOR EXPOSING SMALL ANIMALS TO MICROWAVES	5
1.1 Abstract	6
1.2 Introduction	7
1.3 Methods and materials	8
1.3.1 Power supply	8
1.3.2 Power transmission and monitoring	8
1.3.3 Anechoic chamber	14
1.4 Results and discussion	20
1.5 References for section 1	26
1.6 Acknowledgements for section 1	27
2 FLIGHT, ORIENTATION AND HOMING ABILITIES OF HONEY BEES FOLLOWING EXPOSURE TO 2.45 GHz CW MICROWAVES	29
2.1 Abstract	30
2.2 Introduction	31
2.3 Methods and materials	32
2.4 Results and discussion	36
2.5 Acknowledgements for section 2	40
2.6 References for section 2	41
3 LONGEVITY OF MICROWAVE-TREATED (2.45 GHz CW) HONEY BEES IN OBSERVATION HIVES	43
3.1 Abstract	44
3.2 Introduction	45
3.3 Materials and methods	46

	3.4 Results and discussion	50
	3.5 Acknowledgements for section 3	56
	3.6 References for section 3	57
4	SURVIVAL, DEVELOPMENT, AND TERATOLOGY OF HONEY BEE BROOD (<u>Apis mellifera</u> L.) FOLLOWING EXPOSURE TO 2.45 GHz CONTINUOUS WAVE RADIATION	59
	4.1 Abstract	60
	4.2 Introduction	61
	4.3 Methods and materials	62
	4.4 Results and discussion	66
	4.5 Acknowledgements for section 4	71
	4.6 References for section 4	72
5	CHRONIC EXPOSURE OF A HONEY BEE COLONY TO 2.45 GHz CONTINUOUS WAVE MICROWAVES	73
	5.1 Abstract	74
	5.2 Introduction	75
	5.3 Methods and materials	77
	5.4 Results and discussion	84
	5.5 Acknowledgements for section 5	97
	5.6 References for section 5	98
6	LONGEVITY AND FOOD CONSUMPTION OF MICROWAVE-TREATED (2.45 GHz CW) HONEY BEES IN THE LABORATORY	99
	6.1 Abstract	100
	6.2 Introduction	101
	6.3 Methods and materials	102
	6.2.1 Experimental design	102
	6.2.2 Exposure system	102
	6.2.3 Preparation of materials	104

6.2.4	Post-exposure procedures	107
6.4	Results and discussion	107
6.5	Conclusions	110
6.6	Acknowledgements for section 6	117
6.7	References for section 6	118
7	DYNAMICS OF FOOD FORAGING OF HONEY BEES IN A MICROWAVE FIELD (2.45 GHz CW)	119
7.1	Abstract	120
7.2	Introduction	121
7.3	Methods and materials	123
7.4	Results and discussion	129
7.5	Acknowledgements for section 7	135
7.6	References for section 7	136

FIGURES

1.1	The three basic elements of the microwave exposure system	9
1.2	Schematic diagram of 2.45 GHz CW power supply	13
1.3	Three dimensional exterior view of anechoic chamber	17
1.4	Front view of anechoic chamber showing construction detail	19
1.5	Internal view of anechoic chamber showing exposure platform	21
1.6	Power density distribution within exposure area of chamber	23
2.1	Styrofoam cage for exposing 5 bees in individual compartments	34
3.1	Glass-walled observation hives for post-treatment longevity study	47
4.1	Brood frames showing distribution of capped brood cells in comb	64
5.1	Cross section of anechoic chamber showing colony and runways	78
5.2	Hive inside of anechoic chamber	80
5.3	Daily foraging activity of bees during chronic exposure	85
5.4	Daily pollen foraging activity of bees during chronic exposure	86

5.5	Daily maximum and minimum temperatures within brood nest	87
5.6	Number of cells containing eggs during chronic exposure	89
5.7	Number of cells containing larvae during chronic exposure	90
5.8	Number of cells containing capped brood during chronic exposure .	91
5.9	Number of cells containing honey or nectar	92
5.10	Number of cells containing pollen	93
5.11	Number of empty cells	94
5.12	Weight changes of colony during chronic exposure	96
6.1	Styrofoam cages for confining clusters or individual bees during microwave exposure	106
6.2	Post-treatment wire cages to determine food consumption and bee mortality	108
6.3	Post-treatment survival of bees exposed 24 hours at 0 mw/cm ² . .	111
6.4	Post-treatment survival of bees exposed 24 hours at 3 mw/cm ² . .	112
6.5	Post-treatment survival of bees exposed 24 hours at 6 mw/cm ² . .	113
6.6	Post-treatment survival of bees exposed 24 hours at 12 mw/cm ² . .	114
6.7	Post-treatment survival of bees exposed 24 hours at 25 mw/cm ² . .	115
6.8	Post-treatment survival of bees exposed 24 hours at 50 mw/cm ² . .	116
7.1	Cross section of anechoic chamber showing runway system to foraging arena in exposed area	124
7.2	Mean number of round trips per bee from hive to chambers	130
7.3	Mean round trip time per bee from hive to chambers	131
7.4	Mean time spent within foraging arena in anechoic chamber at various power densities	132

TABLES

1.1	Parts list for power supply unit	10
1.2	Parts list for anechoic chamber	16

2.1	Orientation responses of honey bees exposed 30 minutes to 2.45 GHz CW microwaves and released 100 m from their hive	37
3.1	Surviving bees successfully introduced into observation colonies for longevity determination after 30 min exposures	52
3.2	Longevity of treated bees in glass-walled observation hives . . .	53
3.3	Number of multiple observations during hive censuses	54
4.1	Post-treatment survival of eggs exposed 30 minutes to 6 levels of 2.45 GHz CW radiation	67
4.2	Post-treatment survival of larvae exposed 30 minutes to 6 levels of 2.45 GHz CW radiation	69
4.3	Post-treatment survival of pupae exposed 30 minutes to 6 levels of 2.45 GHz CW radiation	70
6.1	Temperature ranges during exposure in chambers, bee clusters, and in individual bee thoraxes	109

GLOSSARY

- ambient - the natural condition of an environmental factor
- biota - the plants and animals of a region
- brood - the immature stages of development, namely the eggs, larvae and pupae. In the honey bee 20-21 days elapse between laying the egg by the queen and completion of development to the adult stage
- brood nest - the central, somewhat spherical-shaped core of the hive where brood is in the cells and thermoregulation is active
- cm - centimeter
- colony - the entire population of bees, brood, and combs within a hive. This term is often used interchangeably with "hive".
- comb - honeycomb
- comb frames - a section of honeycomb constructed within a wooden frame that fits inside the hive such that it is easily removable for manipulations
- continuous-wave radiation - single-frequency, uniform-amplitude electromagnetic radiation
- dB - decibel; a unit for expressing the ratio of two amounts of electric or acoustic signal power equal to 10 times the common logarithm of this ratio. A ratio of 10 is 10 dB, a ratio of 100 is 20 dB, a ratio of 1000 is 30 dB, etc.
- ecology - a branch of science concerned with the interrelationship of organisms and their environment
- ecosystem - the complex of a community and its environment functioning as an ecological unit in nature
- electromagnetic energy - energy in the entire range of wavelengths of frequencies of electromagnetic radiation extending from gamma rays to the longest radio waves and including visible light
- frequency - the number of complete oscillations per second of an electromagnetic wave, measured in hertz (Hz). One hertz equals one cycle per second
- geosynchronous earth orbit (GEO) - the orbit at which it takes a satellite 24 hr to circle the earth so that it is stationary as viewed from the earth; altitude approximately 36,000 km
- GHz - gigahertz - one billion (1,000,000,000) hertz
- GW - gigawatt - one billion (1,000,000,000) watts; a measure of electric power

Hz - hertz: a unit of frequency equal to one cycle per second

hive - the wooden structure, usually box-like in shape, that contains the colony of bees. Sometimes used interchangeably with "colony".

honeycomb - a mass of hexagonal wax cells built by honey bees in their nest to contain brood and stores of honey and pollen

kg - kilogram: metric measure of mass. One kilogram is about 2.2 pounds

km - kilometer: a metric measure of distance. One kilometer is about 0.6 mile

m - meter: a metric measure of distance. One meter is about 39.8 inches

microwave - a comparatively short electromagnetic wave, especially one between 100 cm and 1 cm in wavelength or, equivalently, between 0.3 and 30 GHz in frequency

mW/cm^2 - milliwatts per square centimeter: unit of energy flow or power density. A milliwatt is 1/1,000 watt

nectar - a sweet aqueous solution secreted in microliter amounts in some flowers, collected by bees, and gradually condensed inside the hive until it becomes honey. Nectar and honey are found in comb cells, the latter usually covered with beeswax as a means of long term storage

poikilothermic - having a body temperature not internally regulated but approximating that of the environment

pollen - microspores of a seed plant that appear as a fine dust. Collected by bees as food that provides most of the essential nutrients except for the carbohydrates of honey. Stored in cells in the brood nest area

power density - the quantity of electromagnetic energy that flows through a given area per unit of time. Formally, power density is specified in watts per square meter (W/m^2), but by tradition in biological effects studies it is usually expressed in milliwatts per square centimeter (mW/cm^2).

queen bee - the fully-developed reproductive female that normally is the source of all eggs laid in the honey bee colony. Only one queen is normally found in a colony

queen excluder - a surface area composed of critically spaced parallel wires or openings that are just large enough to pass worker bees, but too small to permit the passage of the larger queen or drone bees

rectenna - a coined term for the SPS reference system receiving antenna that also converts the microwave power to direct-current electricity

teratology - the study of malformation or serious deviations from the normal development of fetuses

thermoregulation - the control of environmental or body temperature by metabolic or behavioral responses. Honey bees as individuals are poikilothermic but actively regulate the temperature within the brood nest area of the colony at $34 \pm 2^\circ \text{C}$ by increasing metabolic heat and clustering to retain the heat, or by fanning to evaporate droplets of water collected by foraging bees and distributed within the hive

ABSTRACT

A system for small animal exposure was developed for treating honey bees, Apis mellifera L., in brood and adult stages, with 2.45 GHz continuous wave microwaves at selected power densities and exposure times. Post-treatment brood development was normal and teratological effects were not detected at exposures of 3-50 mw/cm^2 for 30 minutes. Post-treatment survival, longevity, orientation, navigation, and memory of adult bees were also normal after exposures of 3-50 mw/cm^2 for 30 minutes. Post-treatment longevity of confined bees in the laboratory was normal after exposures of 3-50 mw/cm^2 for 24 hours. Thermoregulation of brood nest, foraging activity, brood rearing, and social interaction were not affected by chronic exposure to 1 mw/cm^2 during 28 days. In dynamic behavioral bioassays the frequency of entry and duration of activity of unrestrained, foraging adult bees was identical in microwave-exposed (5-40 mw/cm^2) areas versus control areas.

SUMMARY

A proposed solar power system (SPS) would use large solar satellites in geosynchronous orbit to collect solar energy in space and to convert it to microwaves that would be transmitted to earth-based receiving antennae (rectennae) for conversion to electricity. The evaluation of possible biological effects of SPS microwaves on airborne biota within and near the rectennae has high priority in the the SPS environmental assessment program. Honey bees, the first invertebrates to be tested, have been treated in a new exposure system for small animals that was designed expressly for these studies. Exposure power densities ranged from low levels of energy anticipated at rectennal edges (1 mw/cm^2) to approximately twice (50 mw/cm^2) the levels projected at the rectennal center (23 mw/cm^2). Exposure times were 30 minutes to 28 days, which exceed one life cycle.

Sensitive behavioral bioassays following 30-minute exposures up to 50 mw/cm^2 did not detect any biological effects in terms of adult orientation, navigation, memory, longevity within colonies, or the survival of brood. Chronic exposure of an entire colony for 28 days at 1 mw/cm^2 did not reveal any effects in terms of thermoregulation of brood nest, brood rearing, teratology, adult foraging activity, or overall societal activities. Longevity (post-exposure) of adult bees in confinement in the laboratory was not affected by exposures as high as 50 mw/cm^2 for 24 hours. Unrestrained foraging bees from a distant hive made many round trips to the laboratory where they unhesitatingly entered microwave fields up to 40 mw/cm^2 in anechoic chambers to collect artificial nectar while illuminated.

No evidence has been found to suggest that 2.45 GHz continuous wave microwaves at selected power densities from $1\text{-}50 \text{ mw/cm}^2$ have biological effects on honey bees.

INTRODUCTION

Invertebrates comprise a very significant part of the environment, in numbers and in function. More than 95% of all animals, in terms of numbers of individuals or species, are invertebrates. They interact in subtle, yet dramatic ways with plant and animal life. For example, phytophagous insects utilize plants as food and thereby regulate plant populations. Both plant and animal diseases are spread by insects. Plant reproduction is greatly affected by insects that feed on seeds. Perhaps the greatest impact of insects is in pollination. Honey bees, for example, are required to pollinate approximately one-third of the food produced in the United States.

Many insects are airborne during part of their life. Some passively drift great distances, then settle when environmental cues indicate favorable locations for certain activities, such as overwintering in warm areas or feeding. Others actively fly great distances, up to hundreds of miles, in migratory activities. Still others range miles from their nest on a daily basis to forage.

Airborne insects are certain to enter the areas designed for microwave-receiving antennae in the Solar Power Satellite system. The incredible sensitivities of invertebrates to various forms of electromagnetic energy are just beginning to be appreciated. After all, life evolved in an atmosphere pervaded by low levels of non-ionizing electromagnetic energy to which insects have responded by evolving extremely sensitive sensory apparatus that discriminate those stimuli that offer selective advantages. Navigation, for example, frequently involves selective perception of those forms of energy from the sun that penetrate the atmosphere.

By virtue of being poikilothermic, insects have developed strategies for moving to areas where there is a thermal advantage. Would they absorb sufficient energy in the rectennal area to make this an attractive overwintering site, for example? Would other airborne biota, such as birds, then migrate to the area, as they are known to do whenever food resources become concentrated in certain areas? Considering the more than 2 million species of invertebrates in the world, their biological complexities and interspecific interactions,

there is a reasonable probability that invertebrates may interact with the operation of SPS rectennae. It is prudent to expose representative species, at least, to SPS microwaves to determine if biological effects can be detected.

Honey bees are being used initially as a convenient experimental animal to determine if 2.45 GHz continuous wave energy causes biological effects. Basically, the goal of this research program is to determine if the power densities expected within and near the rectennae are safe for honey bees. If so, there is a high probability that other insects will fare well too. However, other species must be tested as an additional safeguard. Because of their small size, invertebrates, especially insects, should be nearly visible to SPS microwaves. This remains to be determined, however, by carefully conducted experiments.

1 A System for Exposing Small Animals to Microwaves

By

Becky Brown Westerdahl, Norman E. Gary

Department of Entomology

University of California

Davis, CA 95616

Joseph S. Ali

Health Effects Research Laboratory

U.S. Environmental Protection Agency

Research Triangle Park, N.C. 27711

John W. McGrath

Department of Physics

University of California

Davis, CA 95616

ABSTRACT

A laboratory system for controlled exposures of small animals has been designed and tested. A 2.45 GHz CW power supply generates up to 300 watts of power with a ripple of $< 2\%$. Power is transmitted by a waveguide system connected to a horn antenna mounted overhead in a double-walled anechoic chamber ventilated by a fan. A 61 X 61 cm exposure area positioned 121 cm beneath the horn is uniformly illuminated at power densities from 0 to 50 mW/cm^2 . Accessory equipment is described for controlling and monitoring transmitted power and for temperature sensing within the anechoic chamber.

INTRODUCTION

The increasing use of microwaves and the attendant increase in ambient levels of microwave energy in the environment has sensitized the public concerning possible biological effects of microwaves on man and other living organisms. This has intensified research efforts to define the real and potential risks to biological materials. One of the most ambitious environmental assessment efforts to date for microwaves has been generated by the proposed Solar Power Satellite (SPS) system [Koomanoff and Sandahl, 1980], in which up to 60 geosynchronous satellites (each 5 X 10 km) would collect solar energy, and transmit it to earth by microwaves (2.45 GHz CW) to receiving antennae (rectennae) ca 10 km in diameter [Glaser, 1980]. Airborne biota entering the rectennal area would be exposed to ca 1 mw/cm² near the edge and up to 23 mw/cm² near the center. Extremely low levels of microwaves from the system would reach large areas outside the rectennae. Societal acceptance of this system is contingent upon thorough testing of SPS microwaves on many organisms to determine the extent of biological effects, if indeed there are significant effects.

The exposure system described herein was designed and tested as a part of the SPS environmental assessment program. It was developed in response to the need for a cost-effective system that could be replicated easily and would simulate accurately the 2.45 GHz CW microwaves expected to be used in the SPS system. In particular, this system was designed for small animals, especially invertebrates [Gary and Westerdahl, 1978].

METHODS AND MATERIALS

The exposure system (Figure 1) evolved from a previous system developed by Guy [1979 and Personal Communication]. It is composed of three major elements, viz., (1) a 2.45 GHz CW power supply unit, (2) a power transmission and monitoring section, and (3) a portable anechoic chamber.

Power Supply

The 2.45 GHz CW power supply consists of an internal transistorized line voltage pre-regulator and a highly filtered DC source that supplies power to a magnetron. The flexibility of the unit is increased by placing the magnetron in a separate cabinet (wt. = ca 5 Kg) which is connected to the power supply unit (wt. = ca 45 Kg) by a high voltage cable. Both units and the cable are shown in Figure 1. The air cooled power supply is capable of generating up to 300 watts with a ripple $< 2\%$. Manipulation of the power output is possible by varying the anode voltage from 3.4 to 3.6 Kv, which has the effect of inducing minor changes in frequency from 2.445 to 2.470 GHz. A parts list (Table 1) and a schematic (Figure 2) are provided. Approximately 80 hours are required for the construction of one unit; parts cost ca \$1000 (1980 dollars).

Power Transmission and Monitoring

Waveguides are utilized for transmitting power to the anechoic chamber to maximize the transmission of power and to maintain wave uniformity. The components visible in Figure 1, beginning with the cabinet containing the magnetron (resting on concrete block on floor),

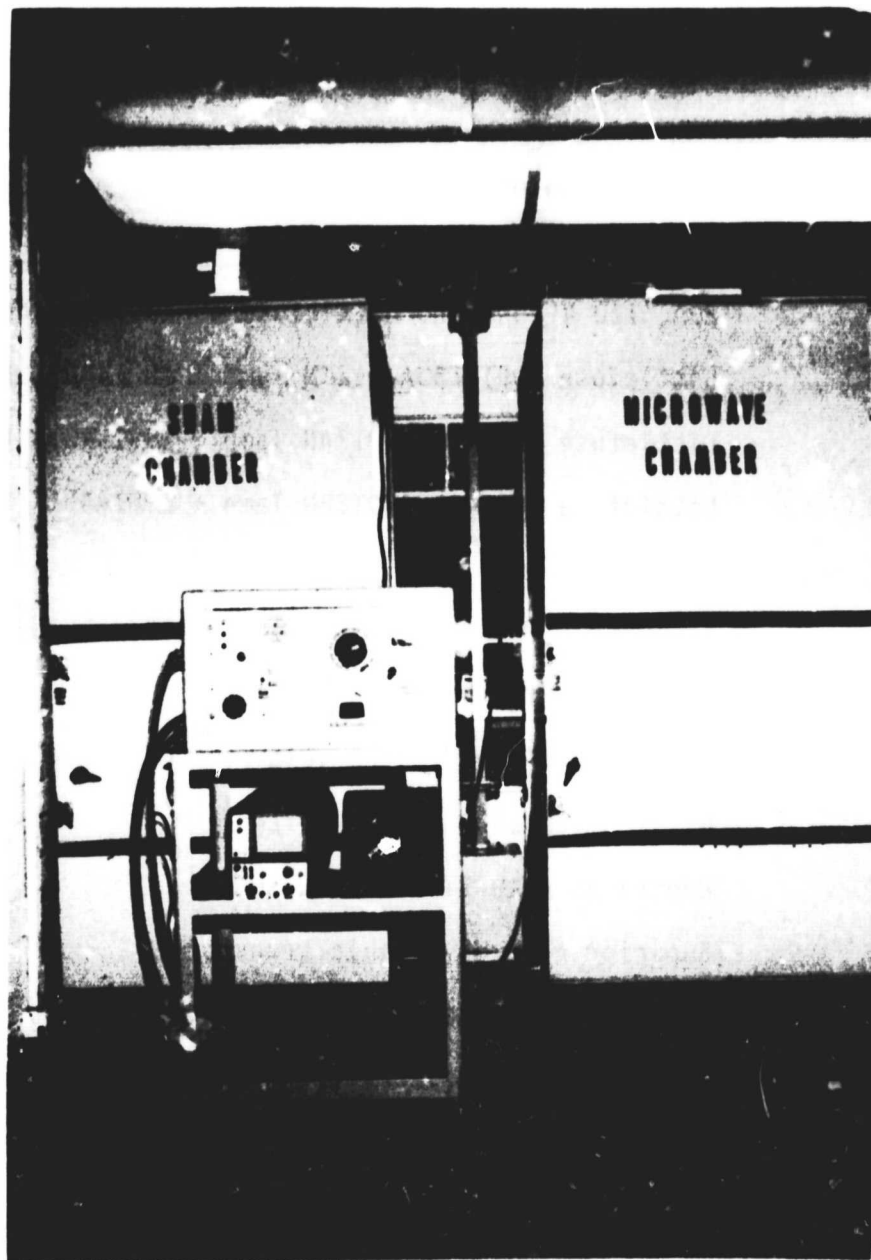

Figure 1.1 The three basic elements of the microwave exposure system (1) 2.45 GHz CW power supply, (2) waveguide power transmission and monitoring system, and (3) anechoic chamber and an identical sham chamber in which control subjects are placed during experiments

Table 1.1 Parts list for power supply unit.

Schematic Reference	Description of parts
F ₁	20A, 120 V fuse and Littlefuse #342014A holder
I ₁	Littlefuse #901-153A-012CN lamp + #901-401X holder
I ₂	Littlefuse #901-153A-012AN lamp + #901-401X holder
I ₃	Littlefuse #901-153A-D12RN lamp + #901-401X holder
FA ₁ , FA ₂	Pamotor #4600K fan
Ry ₁	Amperite #115 NO 60 time delay relay
Ry ₂	Potter Brumfield PRD3-AY0 relay
Ry ₃	Potter Brumfield KAP5AG relay
S ₁	H. H. Smith #988 toggle switch
S ₂	Centralab #CRL-1473 rotary switch.
T ₁	Superior #126-U variable transformer
T ₂	Triad-Utrad PM-540 microwave transformer
T ₃	Superior #10B variable transformer
T ₄	Triad-Utrad #F-17U filament transformer
T ₅	Signal Transformer #241-7-16
T ₆	Signal Transformer #241-6-12
M ₁	G. E. #50-250240 NDND AC ammeter
M ₂	G. C. #D1-920 0-15V meter
D ₁	Motorola #MDA-3500 bridge
D ₂ , D ₃	Varo #VC-40 diode
D ₄	Motorola #MDA-3504 bridge
D ₅ , D ₆	2N3771 transistor

D7, D13	Motorola #MDA-200 bridge
D8	1N4001 diode
D9	RCA SK3024 transistor
D10, D11	Texas Instrument TIP-47 transistor
D12	RCA SK3063 zenor
V1	Litton #L5261A magnetron
L1	Signal Transformer #CH-16 choke
L2	Triad-Ultrad #C-45AL Choke
C1	84,000 μ f, 10V electrolytic cap.
C2 \rightarrow C21	200 μ f, 450V cap electrolytic cap.
C22	5500 μ f, 35V cap
C23	.39 μ f, 35V polycap
C24	.47 μ f, 35V cap.
C25	4.7 μ f, 25V cap
C26	1.0 μ f, 25V cap.
R1 \rightarrow R20	25 K Ω , 8W resistor 10%
R21 \rightarrow R23	100 Ω , 1W resistor 5%
R24, R26	10 K Ω , 1/4W resistor 5%
R25	100K Ω , 1/4W resistor 5%
R27	10K Ω , 1/4W resistor 5%
R28	1 K Ω , 1/4W resistor 5%
R29	2.2K Ω , 1/4W resistor 5%
R30	1.0 K Ω , 1.4W resistor 5%
R31, R32	0.20, 10W resistor 1%
R33	50 Ω , 5W resistor 5%
IC1	Positive 15V, 1A voltage regulator (Motorola MC 7815)

IC2 #741 operationai amplifier

Hardware

1 ea Bud # CR-1736 HG cabinet
1 ea Bud # MB-451 brackets
1 ea Bud # PA-1105 19" pannel
1 ea Bud # PA-1110 19" pannel
1 ea Bud # AC-1428 A1 chassis
1 ea Bud # CU881 cabinet
1 ea Beldon # 8520, # 14 hook up wire, color #1, 30 meter roll
1 ea Beldon #8520, # 18 hook up wire, color # 18, 30 meter roll
1 ea Beldon # 8523, color # 9, # 20 hook up wire, 30 meter roll
1 bx Waldom # T-2014 block spade 100/bx
1 bx Waldom # T-2030 block spade 100/bx
1 bx Waldom # T-2015 block spade 100/bx
1 bx Waldom # T-2033 block spade 100/bx
1 bx Waldom # ST-2090 male slip on 100/bx

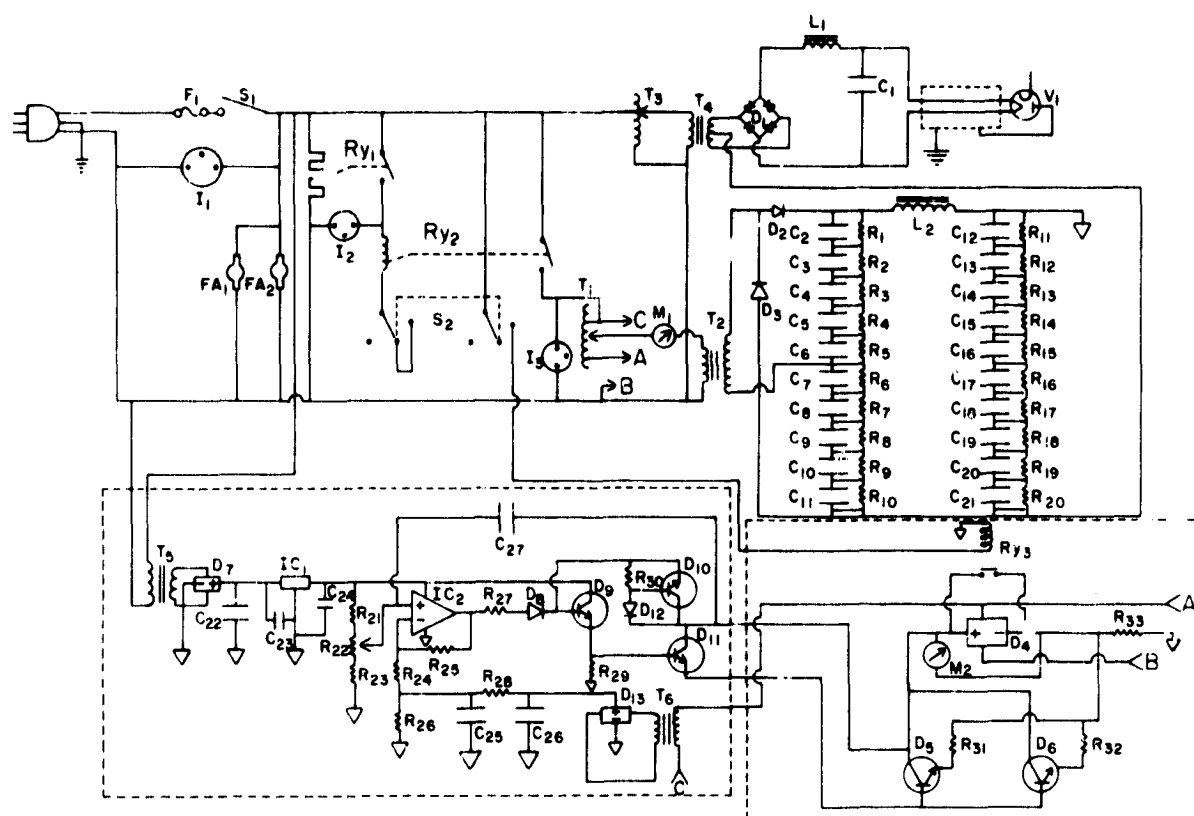

Figure 1.2 Schematic diagram of 2.45 GHz CW power supply.
Referenced parts are described in Table 1.1

and proceeding upward to the top of the anechoic chamber are: (1) a 20 cm straight section (Arra model 284-220-8), (2) a 152 cm straight section (Arra 284-220-60), (3) a 90° E Plane Bend (Arra model 284-400), (4) a cross-guide coupler terminated with an "N" connector (Arra model 284-602-50-N), (5) a 20 cm straight section (Arra model 284-220-8), and (6) another 90° E plane bend (Arra model 284-400). This last E plane bend is coupled directly to a standard gain horn antenna (Narda model 64A). A power detector (Bontoon model 41-4A) is connected to the "N" connector of the cross guide coupler and by a cable (Boonton model 41-2A) to a digital multimeter (Data Precision model 1350), visible on the right side of the middle shelf of the power supply cart. A crystal detector (e.g., Hewlett Packard model 423 A) may be substituted for the power detector and connected to the oscilloscope (Tektronix model T 932 A, shown on the left side of the middle shelf of the power supply cart) to check the wave form from the power supply.

Reduced power levels may be attained by substituting a 10 dB fixed attenuator (e.g. Omega model 922X1 = 152 cm long) for the 152 cm straight section. To obtain power levels below 1 mw/cm² a 0-40 dB variable attenuator (e.g., Omega model 162 = 41 cm long) may be substituted for the 20 cm straight section at the top of the chamber. Because this particular attenuator accommodates a maximum of 60 watts, it must follow the 10 dB fixed attenuator in the system.

Anechoic chamber

The anechoic chamber (Figures 1, 3-5) is constructed of microwave-absorbing materials and situated inside an outer cabinet constructed

of plywood lined interiorly with aluminum sheet. The chamber is separated from the outer cabinet walls to provide a vented air space. A 61 X 61 cm exposure area is situated 121 cm below the opening of the horn antenna. The chamber is designed for use up to 100 mw/cm². The cost per chamber (excluding labor estimated at 50 hours) is ca \$2,800 (1980 dollars). A parts list (Table 2) is provided.

Detailed construction plans are shown in Figure 3. The top (A) is constructed of 1.3 cm thick plywood, lined on the underside with aluminum sheet (60 mm) affixed with Fastbond 30 Contact Cement. A layer of ceramic microwave absorbing material (Emerson and Cuming HT-99) is glued with silicone rubber caulk directly to the aluminum. On top of the chamber is a removable box (B) with a hole (C) to support the horn antenna that extends into the chamber. Semicircular vents (D) (14 cm in diameter) on the front and back of this box are covered with aluminum window screen and serve as air intakes into the center of the chamber top. Additional vents (E and F), also covered with aluminum screen, open into the 5 cm ventilation space between the outer plywood wall and the inner microwave absorber wall to provide passive cooling of the microwave absorbing materials.

Identical doors (J) are located on the front and back of the chamber. A captive key interlock switch (K) automatically turns off the power supply if the door is opened accidentally during operation. A second interlock switch (Archer 49-1) is not visible behind the door in this picture but is shown in Figure 5. Each door is attached with a mortised, continuous hinge (L) and secured by two sash lock latches (M). All four edges of each chamber side (H) have a rim of molding (G) (1.9 X 1.9 cm) glued (Weldwood resorcinol) and nailed in

Table 1.2 Parts list for anechoic chamber.

<u>Quantity</u>	<u>Description</u>
4 sheets	Plywood (244 X 122 X 1 cm)
1 sheet	Plywood (244 X 122 X 1.3 cm)
5 sheets	Aluminum (244 X 91 X 0.06 cm) grade-3003H14
1 each	Fan - Pamotor model 7606
2 each	Single pole captive key switch with enclosure (Unimax Switch Corp. model GW-7-11-P)
1 sheet	Styrofoam (244 X 10 X 61 cm)
2 sheets	Styrofoam (244 X 10 X 61 cm)
1 sheet	Styrofoam (244 X 5 X 61 cm)
1 each	Narda 644 horn antenna
3.8 liters	Fastbond 30 contact cement
0.5 kg	Galvanized nails
2 each	Continuous hinges (61 X 2.45 cm)
15 meters	Square molding (1.9 X 1.9 cm)
5 tubes	Silicone rubber caulk (304 ml each)
4 each	Swivel casters (10 cm diameter)
0.95 liters	Weldwood Resorcinol Waterproof Glue
1 sq. meter	Aluminum window screen
4 each	Sash lock window latches
39 pieces	Emerson and Cuming Eccosorb HT-99 (46 X 31 X 8 cm) ceramic absorber
3 pieces	Eccosorb SF-2.5
1 piece	Eccosorb SPY-12 rubberized absorber
2 rolls	Eccoshield PST-P aluminum tape
2 ea	Interlock Switch (Archer 49-513)

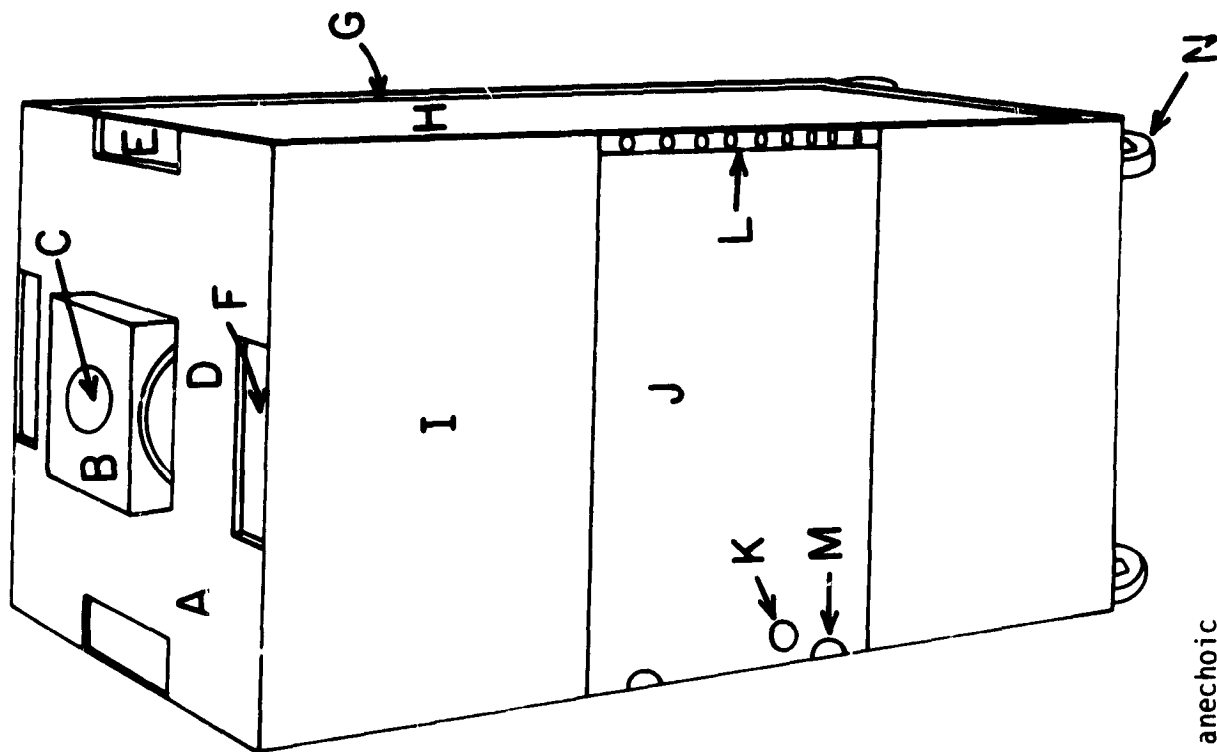

- (A) Plywood top of chamber (88 X 88 X 1.3 cm) which has a square hole (30 cm) in the center for insertion of horn antenna
- (B) Plywood box (31 X 31 X 11.4 cm) constructed from 1.3 cm thick plywood
- (C) Hole in top of box (13.3 cm diameter). One end of a 90° E plane bend is inserted through the hole and the horn antenna is secured by bolts extending through the box
- (D) Semi-circular air vent (14 cm diameter) (covered with aluminum window screen) into interior of chamber
- (E) Air vents (31 X 8.9 cm) (covered with aluminum screen) for passive cooling of air space in both side walls of chamber
- (F) Air vent (31 X 6.4 cm) (covered with aluminum screen) for passive cooling of air space in front and back walls of chamber
- (G) Molding on all 4 edges of side wall to increase strength of butt-joint between sides and front and back of chamber
- (H) Plywood side walls of chamber (194 X 86 X 1 cm)
- (I) Front (or back) wall of chamber (194 X 93 X 1 cm)
- (J) Plywood chamber door (93 X 61 X 1 cm)
- (K) Captive key interlock switch
- (L) Continuous hinge (2.45 cm wide)
- (M) Sash lock
- (N) Swivel casters (10 cm in diameter)

Figure 1.3 Three dimensional exterior view (front or back) of anechoic chamber (not to scale).

place. The chamber sides are butt-jointed (glued and nailed) between the front and back. The entire chamber is supported on four 10-cm high swivel casters (N) to facilitate portability.

A cutaway view of the chamber is shown in a scale drawing (Figure 4). The horn antenna support box (B) (constructed of 1.3 cm plywood) rests on top of the chamber (A). It is also lined with a layer of aluminum sheet to which is affixed (Fastbond 30 contact cement) a layer (0.6 cm thick) of microwave-absorbing material (Emerson and Cuming SF-2.5) (C). The horn antenna (E) extends through a hole in the chamber top. The aluminum window screen covering vent (D) is secured to the aluminum sheet with 5 cm-wide aluminum tape (Emerson and Cuming Eccoshield PST-P). Aluminum screen covering the other air vents (not shown in Figure 4) is also secured with aluminum tape. The multilayered wall is composed of 1.9 cm molding (F), 1 cm thick plywood (G) covered interiorly with aluminum (60 mm) sheet with the seams sealed with aluminum tape (Eccoshield PST-P), a 5 cm air space for ventilation (H) made possible by using 5 cm thick styrofoam spacers (visible in Figure 5) glued (silicone rubber caulk) between the aluminum wall and the anechoic chamber microwave absorbing wall (I) which is built of ceramic microwave bricks (46 X 8 X 31 cm) (Emerson and Cuming HT-99). Additional support for the bricks was provided by silicone rubber caulk applied between the bricks. A styrofoam exposure platform (2.54 cm thick) (J) rests on top of a single piece (61 X 61 X 31 cm) of rubberized pyramidal absorber (Emerson and Cuming SPY-12) (K).

Styrofoam spacers (10 X 10 X 10 cm) support the pyramidal absorber over the 10 cm air space (L) in the chamber bottom. The

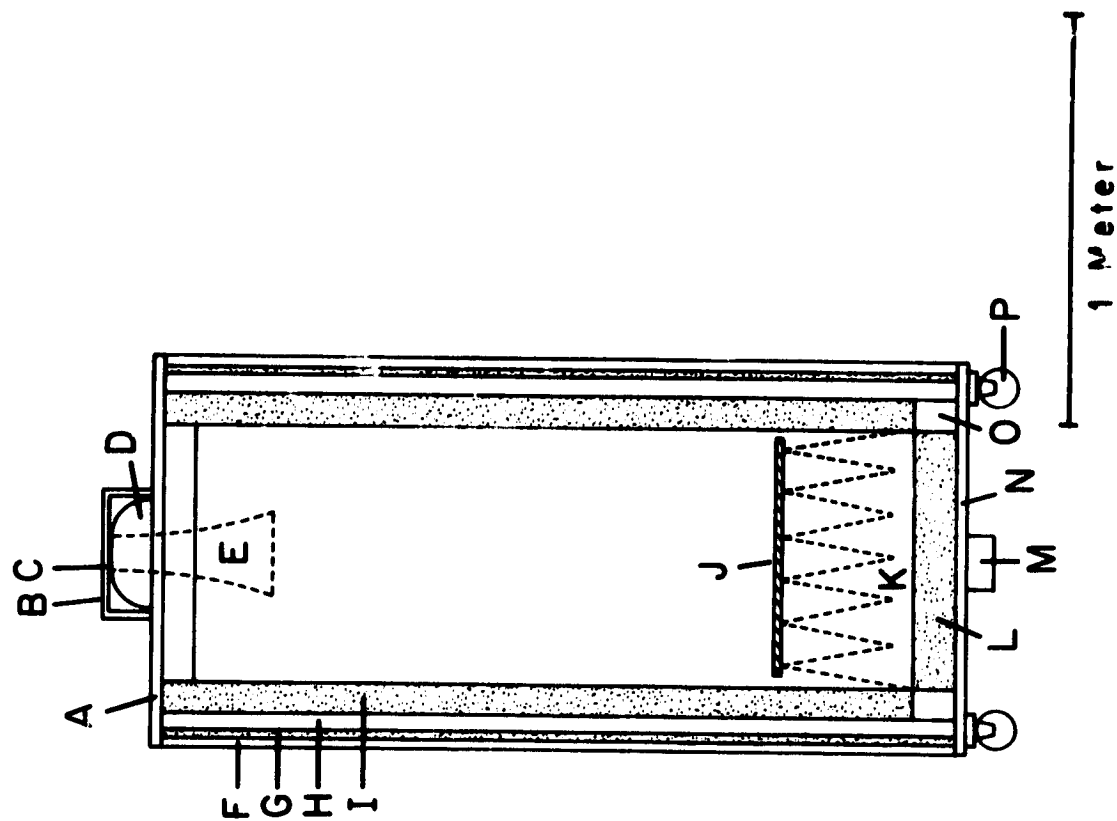

- (A) Top of chamber
- (B) Plywood-aluminum box to support horn antenna
- (C) Microwave absorber (Emerson and Cuming SF-2.5) lining of horn-support box
- (D) Semicircular air vent into center of chamber
- (E) Horn antenna
- (F) Wooden molding
- (G) Plywood-aluminum front wall of chamber
- (H) Air space for passive cooling of absorber materials
- (I) Internal wall of ceramic microwave absorber (Emerson and Cuming HT-99)
- (J) Styrofoam exposure platform
- (K) Pyramidal rubberized microwave absorber (Emerson and Cuming SPY-12)
- (L) Air space at bottom of chamber
- (M) Fan for cooling chamber (Pamotor model 7606)
- (N) Plywood-aluminum bottom of chamber (88 X 88 X 1.3 cm)
- (O) Styrofoam rim supporting wall of ceramic microwave absorber
- (P) Swivel casters

Figure 1.4 Front view (cutaway) of anechoic chamber with outer plywood-aluminum and microwave absorber walls removed to show interior detail

ceramic absorbing wall (I) rests on top of a 10 cm high block of styrofoam (O). A fan (Pamotor model 7606) (M) over a hole in the chamber floor (N) exhausts air, thereby drawing air into the chamber through the upper vents. Casters (10 cm) (P) support the entire chamber.

An internal view of the chamber through an open door (Figure 5, left to right) shows the sash locks, double interlock system, aluminum lining of the plywood wall, vented air space with styrofoam spacers, ceramic absorber wall (note the installation pattern of bricks in the sides and back, also the cutaway bricks at the top and bottom that fit the door snugly to provide a secure closure), and the styrofoam exposure platform.

RESULTS AND DISCUSSION

Seven power supply units and anechoic chambers were constructed and have proven reliable in extended tests. A power supply unit for each exposure chamber is advisable because (1) the cost per power supply unit approximates the cost for waveguide components if a single power supply is used to distribute power to several chambers and (2) it reduces data loss to one chamber in the event of a malfunction.

The advantages of utilizing anechoic chambers with dimensions similar to our chamber have been discussed previously [Guy, 1979]. Our chamber retains most of these advantages such as easy portability on swivel casters, accommodation by laboratories with 8 foot ceilings, and the capability of passage through standard laboratory doorways. The primary advantage of our chamber is that it is designed to accommodate much higher power densities than before, viz., up to 100

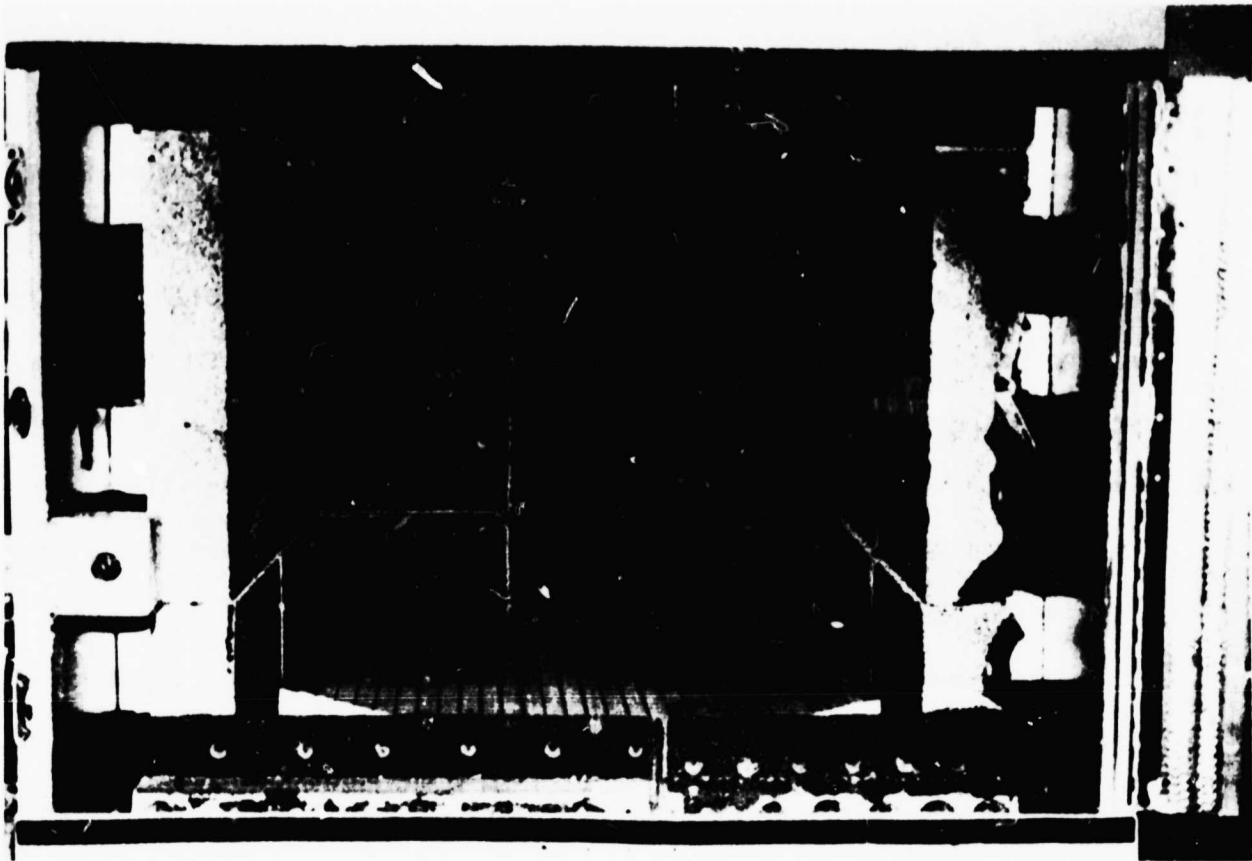

Figure 1.5 Internal view of anechoic chamber through open door showing 5 cm air space for passive cooling, internal chamber constructed of ceramic microwave absorber, and gridded styrofoam exposure platform on which exposed subjects are placed

mw/cm². Another outstanding performance feature is that very uniform power densities are found over the entire surface of the exposure area. We mapped the exposure area with a 3 element orthogonal dipole probe that was custom-built by J. Ali and calibrated against a reference probe at the U.S. National Bureau of Standards. A total of seven scans were made parallel to the chamber doors at 2 cm intervals over an area 16 cm wide in the center of the exposure area. When the power detector was held at 125 mv, the power densities over the exposure platform varied from 1.42 to 3.30 mw/cm² (mean and standard deviation = 2.43 ± 0.39) (Figure 6).

This exposure system was modified easily for specific objectives in six different studies conducted with honey bees. Chambers could be connected together, one serving as the microwave treatment chamber and the second as a sham (control) chamber, by removing fans from the chamber bottoms and installing an insulated metal duct to enable the sharing of common atmospheric elements. Active air flow between chambers is achieved by replacing the horn in the sham chamber with a fan to exhaust air and/or installing an air inlet on the upper vent system of the microwave chamber to push air through the system. Thus, we were able to expose bees in the sham chamber to any microwave chamber odors, including pheromones (chemical messengers) potentially released by bees if they were stressed by exposure. Connection of the two chambers also served to equalize temperature and humidity within the two chambers as well as to expose bees uniformly to any odorous materials generated by possible interaction of microwaves with absorbing materials. The exhaust duct from the sham chamber was vented outdoors. We found that the chamber could be operated

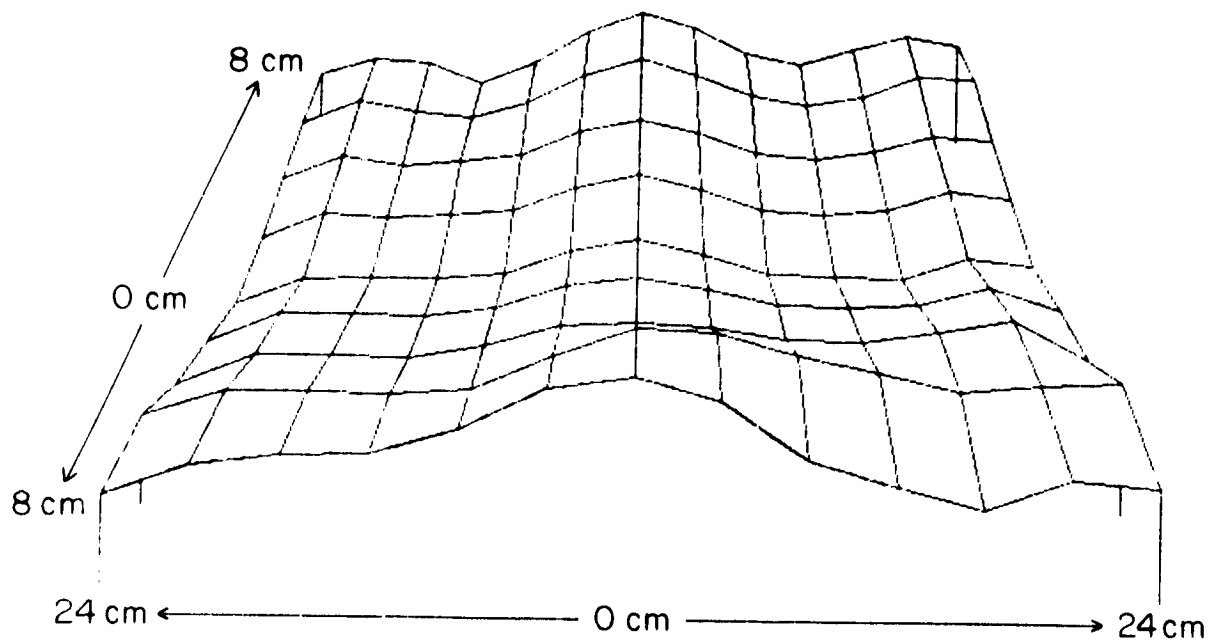

Figure 1.6 Power density distribution within exposure area of anechoic chamber

indefinitely at 50 mw/cm^2 with an increase in chamber ambient air temperature less than 5° C above ambient laboratory temperature. Further temperature manipulation during extended exposures at higher power densities is possible in both chambers by connecting appropriate cooling and heating systems to the intake of the microwave chamber and/or to the connecting duct.

In other studies we found that holes (1.3 cm diameter) could be made in the chamber walls to accommodate plexiglas® tubes (0.95 cm I.D.) to allow honey bees, trained to fly from distant outdoor colonies to entrances in the laboratory walls, to enter and leave the anechoic chamber where they were allowed to forage during exposures. Microwave leakage was insignificant at these openings.

Temperature monitoring during microwave exposure was accomplished initially by placing multiple liquid-crystal thermometer strips (American Thermometer Company) within the chamber. Later we used a 4-probe unit [Christensen, 1977] in which gallium-arsenide fiber optic probes (0.45 mm diameter) were inserted into the chamber through plexiglas® tubes (0.3 cm I.D. and 0.6 cm O.D.) inserted through holes in the bricks just below the door (several are visible in Figure 5) that angle upward toward the exposure platform. Chart recorders (Omniscribe model B5237-5) were utilized to record temperatures continuously during exposures. Temperatures within the sham chambers were monitored with copper-constantan thermocouples inserted through plexiglas® tubes as in the treatment chamber. The thermocouples were connected to electronic ice-point references (Omega model MCJ-T) and data were recorded on chart recorders.

Overall, the system has is versatile and should significantly

facilitate studies that require large numbers of chambers for replicating exposures of small animals, especially invertebrates.

REFERENCES

- Christensen DA (1977): A new non-perturbing temperature probe using semiconductor band edge shift. *J. of Bioeng.* 1:541-545.
- Gary NE, Westerdahl BB (1978): Study of the biological and ecological effects of energy transmission by microwaves on behavior of insects and other terrestrial invertebrates. In Newsom BD: Research plan for study of biological and ecological effects of the solar power satellite transmission system. NASA Contractor Report 3044, pp. 144-202. Available from National Technical Information Service, Springfield, Virginia 22161.
- Glaser PE (1980): The earth benefits from solar power satellites. *Space Solar Power Review* 1:9-38.
- Guy AW (1979): Miniature anechoic chamber for chronic exposure of small animals to plane wave microwave fields. *Journal of Microwave Power* 14:327-338.
- Koomanoff FA, Sandahl CA (1980): Status of the satellite power system concept development and evaluation program. *Space Solar Power Review* 1:67-77.

ACKNOWLEDGEMENTS

This research was supported by the Department of Energy through Argonne National Laboratory (contract numbers 31-109-38-4442 and 31-109-38-5066), and by the National Aeronautics and Space Administration (contract number NAS2-9539).

We thank J. Brandon, K. Lorenzen and T. Webster for their assistance in chamber construction; D. Christensen and O. Gandhi (University of Utah), A. W. Guy (University of Washington), and L. Heynick and P. Polson (Stanford Research Institute) for engineering assistance.

"Page missing from available version"

2 Flight, Orientation and Homing Abilities of Honey Bees
Following Exposure to 2.45 GHz CW Microwaves

By

Norman E. Gary and Becky Brown Westerdahl
Department of Entomology
University of California
Davis, California 95616

ABSTRACT Foraging-experienced honey bees retained normal flight, orientation, and memory functions after 30 minutes exposure to 2.45 GHz CW microwaves at power densities ranging from 3 to 50 mw/cm². These experiments were conducted at power densities approximating and exceeding those that would be present in receiving antennae of the proposed solar power satellite (SPS) energy transmission system and for a duration exceeding that which honey bees living outside of rectennae might be expected to spend within rectennae on individual foraging trips. No evidence was generated that airborne invertebrates would be affected significantly during transient passage through microwaves associated with SPS ground-based microwave receiving stations.

INTRODUCTION

Enormous quantities of solar energy could be collected in space by geosynchronous solar-power satellites (SPS). This energy could be transmitted by microwaves from the satellite, and converted at the earth's surface to electrical energy. Each SPS could produce approximately 5 Gigawatts, the equivalent of several nuclear plants. This concept, first conceived by Peter Glaser (1968) and reviewed recently by Kraft and Piland (1980), has great potential for meeting global energy needs by using the sun's inexhaustible energy (Glaser, 1980). Studies to assess the feasibility of the SPS project (Koomanoff and Sahdahl, 1980) include a commendable effort to anticipate, rather than react to, potential environmental problems. One concern is the potential biological effects on airborne biota that cannot be excluded from earth-based microwave receiving stations where 2.45 GHz continuous wave microwaves (CWM) at maximal power densities of 23 mw/cm^2 would be received near the rectenna center. The behavior of birds and flying insects in the rectennal areas could be a crucial element. Possibly in cold weather they may be attracted by a thermal advantage, owing to microwave absorption. Attractive nest sites may be created inadvertently, depending upon the construction design of the rectenna. Or airborne biota may be repelled by sensing the microwaves and their associated magnetic and electric fields (Gould, 1980). Orientation and navigation possibly could be affected, as well as other behavior that is essential for survival. Almost no information is available on the biological effects of CWM on airborne biota.

Our objective is to assess potential biological effects of CWM on invertebrates. The research plan for this program has been previously

described (Newsom, 1978). In this study we used the honey bee, Apis mellifera L., a species that is ideal for research purposes and also ecologically and economically important, especially as the primary pollinating agent for approximately 1/3 of the food produced in the United States. Honey bees are also vital for pollinating flora that provide food for wildlife and help to prevent erosion.

In honey bee colonies thousands of bees make multiple, daily foraging trips for nectar, pollen, and water at sources within approximately 5 km from their hives (Gary 1979). Successful return flights from these trips require the proper functioning of various mechanisms involved with metabolism, neuromuscular coordination, orientation, navigation, and memory. After returning to the apiary, entry into their own hive requires a high degree of visual discrimination, especially when hives similar in appearance are in proximity. In this study these behaviors were used collectively as a bioassay in which experienced foraging bees were treated with CWM and then released near the apiary to determine the frequency of successful return to the apiary and to the correct hive within the apiary. These data permitted quantification of any performance decrements caused by CWM exposures. The basic premises are that the expression of any of these behavioral events is contingent upon normally functioning underlying physiological mechanisms and that performance decrements would be induced by any adverse CWM effects.

MATERIALS AND METHODS

We arranged five hives in a 1.5-m circle; hive entrances were oriented toward the center. From each hive we captured 120 foraging-experienced, pollen-laden bees as they were entering their respective hives during mid-morning. We identified each bee by gluing a numbered

plastic tag (tags manufactured for bees by Chr. Graze KG, 7056 Weinstadt-Endersbach, West Germany) on the thorax and placed it into a compartmentalized cage that held 5 bees (Fig. 1). Cages were assigned randomly to one of the following groups: (i) Microwave-Treated (MT), in which two cages (10 bees) from each colony were exposed, respectively, in a treatment chamber to one of 5 levels of CWM, viz., 3, 6, 9, 25, and 50 mw/cm² for 30 minutes, (ii) Sham Controls (SC) in which two cages (10 bees) from each colony were placed in a sham irradiation chamber concurrently with each MT group, (iii) Laboratory Controls (LC) and Hive Controls (HC) in which two cages (10 bees) from each colony for each group were held in a separate laboratory for the duration of all microwave treatments. All confined bees had continuous access to a 3 mm ball of invert sugar fondant as food. Water was available continuously, except during the 30-min. exposures to microwaves, by resting inverted cages on water-saturated sponges so that bees could insert their proboscis through the apertures of the plastic screen to reach the wet surface.

Microwave radiation utilized for treatments was generated by a 2.45 GHz continuous wave power supply capable of generating up to 300 watts of power with ripple not exceeding 2%. Radiation was transmitted by waveguides from the power supply to a Narda-644 horn antenna mounted in the top of a rectangular exposure chamber. Walls were lined with Eccosorb HT-99 (Emerson and Cuming). The treatment area (61 x 61 cm) was a styrofoam platform (4 cm thick) located 121 cm from the horn and resting on SPY-12 absorber (Emerson and Cuming). Microwave energy entering the chamber was continuously monitored with a Boonton 41-4A power detector. A crystal detector (Hewlett-Packard) was periodically

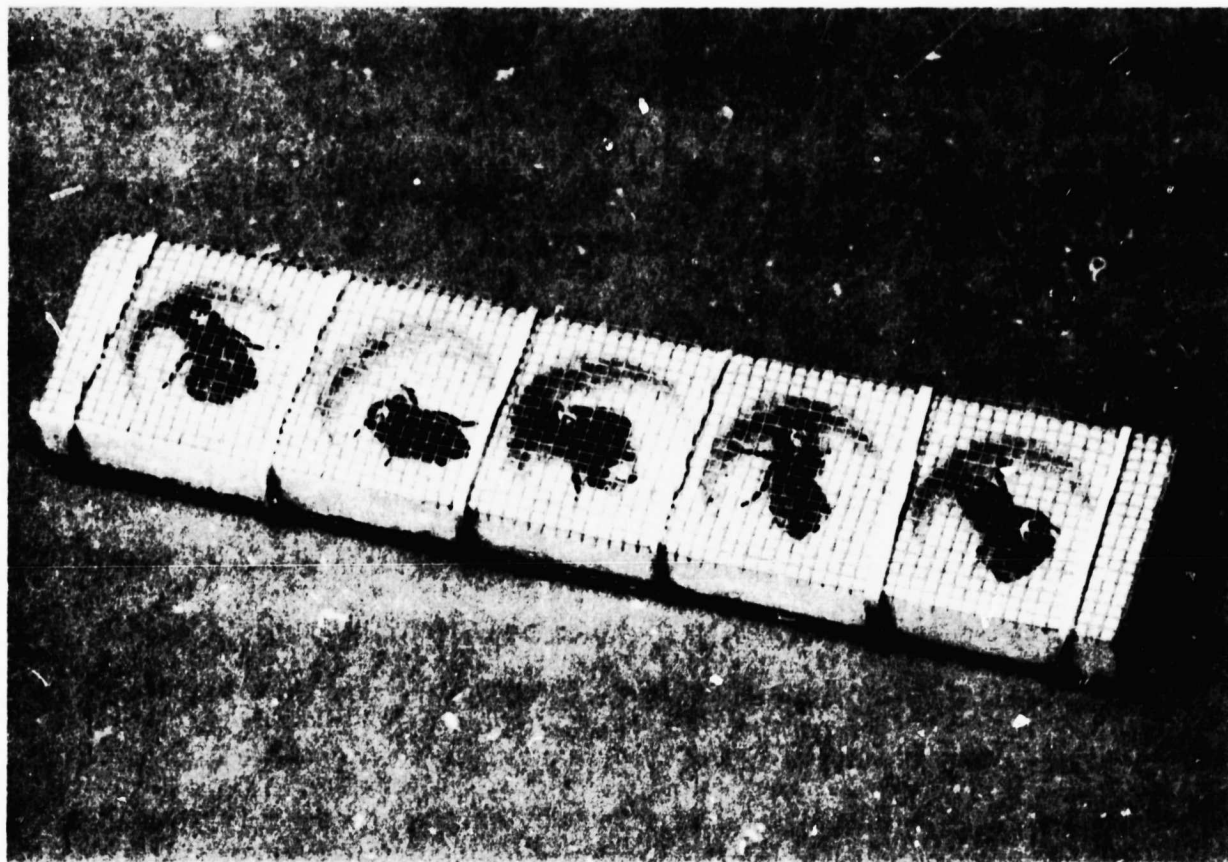

Figure 2.1 Microwave-transparent styrofoam cage containing 5 compartments for confining bees individually. Fiberglass screen on top and bottom is secured with rubber bands. Invert sugar fondant is accessible through a hole in the floor of each compartment, and held in place by Scotch tape. Water is provided by placing top screen in contact with a wet sponge that can be reached by the bees through the screen apertures

substituted for the Boonton detector to check the wave-form from the power supply. Exposures at 25 and 50 mw/cm^2 were conducted by utilizing the waveguide system and varying the power to the magnetron. Lower power levels were produced with the use of an attenuator.

The sham chamber was constructed identically to the treatment chamber and connected to the treatment chamber as a means of receiving a constant flow of effluent air and sharing any chamber odors or pheromones that may be released by treated bees. This arrangement also equalized ambient air humidity (38-66% RH) and temperature (24-30° C.) in both chambers during the respective treatments.

During exposure, 5 compartmentalized cages (13 x 2.5 x 1 cm) (Fig. 1) were placed adjacent to each other on each of two styrofoam platforms (18 x 12 x 2.5 cm) with a separation of 1 cm between the long axis of the cages. The two platforms were placed in the chamber, 118 cm from the horn, one on either side 18 cm from the center in the H plane, with the long axis of the cage parallel to the H plane and the center of the platform located 30 cm from the front of the chamber. The average specific absorption rates for an isolated bee in watts/kg for E, K and H polarizations are 0.5042, 0.0301 and 0.0252, respectively, for an incident power density of 1 mw/cm^2 . These estimates (made by Carl Durney of the University of Utah) are based on a lossy dielectric, spheroidal model and a long wavelength approximation.

During late afternoon after all treatments were completed the MT, SC, and LC bees were transferred outdoors to a release site 100 m from their hives. Releases were made into a plastic tray with lubricated (Petrolatum) side walls that prevented escape by walking in the event released bees were unable to fly. We released the bees of the HC group

directly into their respective hives through a hole in the hive cover to circumvent the necessity of flight from the release site to the apiary. The HC group served as an additional control on the acceptance of tagged bees by the colonies and provided a means to assess our method of recovering tagged bees from the hives. On the next 3 days after each release we carefully examined all combs of bees in all hives at dawn (before foraging commenced) and recovered the tags from all groups.

Our sampling, treatment, release, and census-taking procedures were conducted on each of 10 days, yielding a total of 6,000 bees in the experiment.

RESULTS AND DISCUSSION

Weather conditions were ideal for bee flight during release times. Released bees either flew quickly from the cages and departed from the site or remained in the collection tray if they could not fly. We observed no behavioral differences in any groups. Of the 6,000 tagged bees, 64 (1.1%) died prior to treatment, 207 (3.5%) died after treatment and prior to release or were moribund at release time, 5729 (95.5%) flew when released, and 5166 (86.1%) returned successfully to the apiary, of which 4908 (95.0%) successfully returned to the correct hive.

Data were submitted to analysis of variance and orthogonal comparisons were made (Table 1). We found no significant differences in the frequency of successful return to the apiary for any of the treated, sham, or control groups. Slightly fewer MT bees returned to the apiary than sham bees, regardless of the power density levels, which could suggest the possibility of mild electromagnetic effects on the more sensitive individuals. However, MT and SC groups did not vary significantly from LC or HC groups.

Table 2.1 The responses of honey bees exposed 30 minutes to 2.45 GHz continuous wave microwave radiation and released 100 m from their hives. Each value is the mean \pm 1 standard deviation. All means are based on 50 groups of 10 bees each, sampled daily from 5 hives during 10 days, yielding a total of 6,000 bees.

Mean number of bees per 10 bee groups				
Treatment (mw/cm ²)	Returned to apiary	Returned to wrong hive in apiary	Died after treatment	Not accounted for after release
3	8.4 \pm 1.6	0.4 \pm 0.7	0.4 \pm 0.7	1.1 \pm 1.3
sham	8.5 \pm 1.3	0.5 \pm 0.7	0.3 \pm 0.6	1.0 \pm 1.1
6	8.6 \pm 1.3	0.5 \pm 0.8	0.6 \pm 0.8	0.8 \pm 0.8
sham	8.7 \pm 1.3	0.4 \pm 0.5	0.2 \pm 0.5	1.0 \pm 1.1
9	8.5 \pm 1.4	0.5 \pm 0.7	0.3 \pm 0.7	1.0 \pm 1.0
sham	8.9 \pm 1.1	0.4 \pm 0.7	0.2 \pm 0.4	0.8 \pm 1.0

25	8.5 ± 1.4	0.4 ± 0.5	0.3 ± 0.7	1.0 ± 1.1
sham	8.7 ± 1.3	0.4 ± 0.6	0.3 ± 0.6	1.0 ± 1.1
50	8.3 ± 1.2	0.5 ± 0.7	0.5 ± 0.8	0.9 ± 0.8
sham	8.6 ± 1.1	0.6 ± 0.9	0.3 ± 0.5	0.9 ± 1.0
Laboratory				
Controls	8.5 ± 1.5	0.4 ± 0.9	0.5 ± 0.8	1.0 ± 1.1
Hive				
Controls	8.9 ± 1.1	$0.2 \pm 0.7^*$	0.3 ± 0.6	0.6 ± 0.8

* Bees flew to other hive after release in the correct hive.

A low frequency of bees returned to the wrong hives in the apiary (Table 1). We observed no significant differences between any groups. This evidence indicates no problem of orientation or visual discrimination within the apiary. When hives similar in appearance are in proximity the shifting of some bees between hives, referred to as "drifting", is normal behavior.

Mortality of bees after treatment and before release (Table 1) did not significantly differ among any of the groups and approximated normal daily mortality of bees that are old enough to forage. Bees of foraging age live only approximately 2-3 weeks during summer months.

Bees that flew from the release site but were not recovered at the apiary presumably were lost in the area. Significantly more HC bees were accounted for after release, owing to release directly into the hives. A small percentage of bees from MT, SC, and LC groups may have returned to the apiary but left the hives prior to the census. Rejection of some bees by colonies is not uncommon when they have been held out of the colony for hours and submitted to procedures that may alter their odor and/or behavior.

Our data indicate the absence of statistically or biologically significant effects, either beneficial or detrimental, of CWM on confined honey bees that are exposed individually for 30 minutes at power densities proposed for use in the SPS system at rectennal sites where 'M would be received. This study suggests that airborne invertebrates approximating the size of honey bees would not be affected significantly when flying or passively drifting through CWM within rectennal areas.

ACKNOWLEDGEMENTS

This research was supported by the Department of Energy (Argonne National Laboratory contract numbers 31-109-38-4442 and 31-109-38-5066) and NASA (contract number NAS2-9539).

We thank J. Ali, EPA-Research Triangle Park and J. McGrath, U.C. Davis for engineering consultation; Shu Geng, U.C. Davis for statistical consultation; J. Brandon, S. Cobey, R. Ebadi, P. Harizanis, O. Kaftanoglu, M. Kurtz, K. Lorenzen, S. Molnar, and R. Page from U.C. Davis for assisting with the research.

REFERENCES

- Gary, N. E. (1979): Factors that affect the distribution of foraging honey bees. Md. Agric. Exp. Sta. Spec. Misc. Publ. 1, 353-358.
- Glaser, P. E. (1968): Power from the sun: Its future. Science 162:857-886.
- Glaser, P. E. (1980): The earth benefits of solar power satellites. Space Solar Power Rev. 1:9-38.
- Gould, J. L. (1980): The case for magnetic sensitivity in birds and bees (Such as it is). Amer. Sci. 68:256-267.
- Koomanoff, F., Sandahl, C. (1980): Status of the satellite power system concept development and evaluation program. Space Solar Power Rev. 1:67-77.
- Kraft, C.C. Jr., Piland, R. O. (1980): The solar power satellite concept - The past decade and the next decade. Space Solar Power Rev. 1:39-65.
- Newson, B. D. (1978): Research plan for study of biological and ecological effects of the solar power satellite transmission system. NASA Contractor Report 3044, p. 144-203, Available from National Technical Information Service, Springfield, Virginia 22161.

3 Longevity of Microwave-Treated (2.45 GHz CW) Honey
Bees in Observation Hives

By

Norman E. Gary and Becky Brown Westerdahl

Department of Entomology

University of California

Davis, CA 95616

ABSTRACT

Adult honey bees were exposed for 30 minutes to 2.45 GHz CW microwave radiation at power densities ranging from 3 to 50 mw/cm². Following exposure, bees were returned to glass-walled observation hives and their longevity compared to that of control bees.

No significant differences were found between microwave- and sham-treated bees at any of the power densities tested.

INTRODUCTION

A system of Solar Power Satellites (SPS) has the potential for providing the United States with a large share of its electric energy needs in the first quarter of the 21st century (Glaser 1980). Satellites would be in geosynchronous orbit above the earth, collect solar energy, transport this energy to earth via microwave beams, and convert it to electricity at receiving antennae (rectennae) ca 10 km in diameter. The Department of Energy and the National Aeronautics and Space Agency have conducted in a feasibility study to assess the possible impact of this far-reaching technology (Koomanoff and Samdahl 1980). The leaders of this program have pursued aggressively a program to elucidate any potential economic, societal, environmental or engineering impacts that would be sufficiently serious to cause abandonment of this project.

One major environmental concern is that airborne biota, including invertebrates and birds, cannot be fenced out of rectennal areas and would therefore be exposed to 2.45 GHz continuous wave microwave radiation at levels from 1 mw/cm² at the outer edge to 23 mw/cm² at the center. This study is part of a research program initiated specifically to determine the health and safety of invertebrates that would be found within and surrounding rectennae. Although initial studies involve only the honey bee Apis mellifera L. the overall research plan includes additional invertebrate species (Newsom 1978).

Engineering theory predicts that small invertebrates should be "invisible" to microwave radiation because of the wavelength (12.5 cm) utilized by the SPS system, and therefore be unaffected

by exposure. However, the complexities of biological systems dictate that experiments be conducted to determine if there are, in fact, any detectable biological effects.

The honey bee was chosen for initial experiments for many reasons, e.g., (1) it is a flying invertebrate that ranges far from its nest and cannot be excluded from the rectennae, (2) large numbers can be studied for the duration of its short life cycle, (3) highly stereotyped behavioral patterns can be analyzed and are expected to provide a bioassay system that is more sensitive to microwave radiation than genetic, biochemical or physiological systems, (4) honey bees are sensitive to various forms of electromagnetic radiation (e.g., Altmann & Warnke 1976, Greenberg et al. 1978, Paul & Warnke 1975), and (5) honey bees are an economically important species by virtue of pollinating crops that account for ca one-third of the food production in the United States.

The objective of this study is to determine if the longevity of honey bees is altered by short term exposure to microwave radiation (2.45 GHz continuous wave).

MATERIALS AND METHODS

The experiment was conducted as a $5 \times 5 \times 2 + 1$ factorial in a 5×5 Latin Square with the factors being 5 colonies, 5 treatment levels (3, 6, 9, 25 and 50 mw/cm^2), 2 exposure chambers (microwave and sham) plus an additional control held within the laboratory. There were 50 bees per treatment group. All microwave exposures were for 30 minutes. The longevity of treated bees was determined by post-treatment survival of bees in glass-walled observation hives (Gary and Lorenzen 1976) (Fig. 1) where continuous intra-nest observations



Figure 3.1 Glass-walled observation hives, each containing micro-wave-treated, sham, and laboratory control bees in a population of approximately 7,000 bees. Portholes through the laboratory wall permitted normal foraging. Inset shows experimental bees identified by numbered plastic tags glued to the thorax

were possible without interfering with normal colony activities. Each hive contained a queen and ca 7,000 workers on two brood and two honey combs (comb size = 20 X 43 cm). A runway from each hive extended through the laboratory wall to the outside, allowing bees to forage normally.

On each of 5 consecutive days (July 30-August 3, 1979) all bees were removed from one of the hives and released in a small, darkened room on a platform abutting a vertical glass window with natural back-lighting, the sole source of illumination. Bees were highly attracted to the glass surface where they were sampled randomly and placed in pairs in 8-mesh wire cylindrical cages (2.5 X 10 cm). After sampling, the remaining bees were returned to their hive. The confined bees had access to food (fondant of invert sugar and water) and water throughout the experiment, except during the 30-minute treatment period. Caged bees were narcotized by exposure to carbon dioxide for 20 sec to permit a numbered, plastic identification tag to be glued to the thorax (tags manufactured for bees by Chr. Graze KG, 7056 Weinstadt-Endersbach, West Germany). For this study, the normal series of 500 numbers, composed of 5 base colors containing 100 numbers each, was extended to 2750 by the addition of various colored dots of Pactra Aero Gloss Hot Fuel Proof Dope (Pactra Industries, Inc., Los Angeles, CA 90028) applied to the tag edge. Immediately after tagging, each bee was placed in one of five compartments (2 cm dia., 0.7 cm deep) in a rectangular (13 X 2.5 X 1 cm) styrofoam exposure cage covered with fiberglass screen (8 threads/cm) secured with 6 rubber bands spaced at intervals along the cage.

Ten cages of bees were assigned randomly to each of the 11

groups (5 microwave treatment levels, 5 sham exposure groups and the additional control group), then placed on portable styrofoam platforms to facilitate movement in and out of the chambers and to permit recording of the precise location of each tagged bee within the chambers. The order in which the microwave treatments and their corresponding sham exposures were conducted each day was dictated by a 5 X 5 Latin Square such that each of the five 30-min treatment levels occurred in a different order on each day.

Temperature in the chambers was measured with liquid crystal thermometers (2 within each chamber) and recorded before and after each exposure period. A recording hygrothermograph was present in the sham chamber throughout the study. Exposures were completed within ca 8 hours after the time when bees were first removed from their respective colonies.

Microwave radiation utilized for treatments was generated by a 2.45 GHz continuous wave power supply capable of generating up to 300 watts of power with ripple < 2%. Radiation was transmitted by waveguides from the power supply to a standard gain Narda (model 644) horn antenna mounted in the top of a rectangular exposure chamber. Walls were lined with Eccosorb HT-99 (Emerson and Cuming). The treatment area (61 X 61 cm) was a styrofoam platform (4 cm thick) located 121 cm from the horn and resting on SPY-12 absorber (Emerson and Cuming). Microwave energy entering the chamber was monitored continuously with a Boonton 41-4A power detector. A crystal detector (Hewlett-Packard) was substituted periodically for the Boonton detector to check the wave-form from the power supply. Exposures at 25 and 50 mw/cm^2 were conducted by utilizing the waveguide system

and varying the power to the magnetron. Lower power levels were produced with the use of an attenuator.

The sham chamber was constructed identically to the treatment chamber and connected to the treatment chamber as a means of receiving a constant flow of effluent air and sharing any chamber odors or pheromones that may be released by treated bees. This arrangement also equalized ambient air humidity (38-66% RH) and temperature (24-30°C) in both chambers during the respective treatments.

After all exposures had been completed for the day, bees were released directly into the runway leading to their hive. Beginning the day after release, a census of surviving bees was taken in each colony at least once each day. A plexiglas® grid placed against the observation hive glass wall permitted the observer to scan the combs systematically while recording observations on a tape recorder. Observations were continued until August 31, 1979, yielding a total of 50 censuses (28 morning and 22 afternoon).

RESULTS AND DISCUSSION

Eighty percent (2,217) of the 2,750 bees tagged during the study were observed at least once during the post-treatment censuses. Bees not observed may be accounted for in part by rejection following introduction (primarily because of odors introduced in handling and the period of time bees were isolated from colony odors), normal mortality prior to being observed (ca 3-5% daily is expected), and the loss of some tags (sometimes removed by other bees during grooming). The numbers of tagged bees observed on the first day post-treatment in the 5 hives were 409, 412, 466, 496, and 434, respectively, with a mean of 443 and a standard deviation of 33 bees. These variations

were not significantly different. Surviving bees constituted 80% (999 bees) of the microwave exposure group, 81% (1,012) of the sham group and 82% (41) of the laboratory control group. The remaining data are shown in Table 1. No significant differences were found between the surviving bees observed in corresponding microwave and sham exposure groups or between any microwave or sham groups, compared to the laboratory control group.

A preliminary analysis of the data indicated that longevity for microwave, sham, and control groups was similar and that less than 20% of the bees treated were still alive 21 days following exposure. Subsequently, data analysis on surviving bees was restricted to censuses taken on days 1, 6, 11, 16 and 21 following exposure (Table 2). No significant differences were found in the longevity of any of the treated, sham, or control groups.

Approximately 50% of the bees present in a colony were observed in any one census. Some bees could not be observed because they were inside cells, on the top, bottom or sides of comb frames, or simply positioned such that tags were not visible. The general trend was that ca 50% of the surviving bees were observed in the hives on the first day following exposure, diminishing to ca 30% on day 11 and 15% on day 21 post-treatment.

Because of the mobility of bees within the colony, some bees were observed more than once during a single census. The frequency of multiple observations was analyzed (Table 3) to assess the possibility that bees may have become hyperactive, with resulting increased mobility, as a result of microwave treatment. This frequency was predictably greater at the beginning of the observational period because

Table 3.1 Number of bees present in glass-walled observation colonies following 30 minute exposures to 2.45 GHz continuous wave microwave radiation. 550 bees were sampled from a different colony on each of 5 consecutive days and divided into 11 treatment groups of 50 bees each.

Treatment (mw/cm ²)	Number of bees per 50 bee groups					Treatment Total	Mean	S.D.
	1	2	3	4	5			
3	37	35	43	41	35	191	38.2	3.3
sham	35	39	44	46	42	206	41.2	3.9
6	37	37	40	44	43	201	40.2	2.9
sham	38	35	42	45	43	203	40.6	3.6
9	37	37	41	48	35	198	39.6	4.6
sham	33	37	42	43	44	199	39.8	4.2
25	34	41	43	46	36	200	40	4.4
sham	40	38	42	46	37	203	40.6	3.2
50	41	40	43	47	38	209	41.8	3.1
sham	28	38	43	45	37	201	40.2	3.2
control	39	35	43	45	44	206	41.2	3.7

Table 3.2 Longevity of bees within glass-walled observation colonies following 30 minute exposures to 2.45 GHz continuous wave microwave radiation. Each value is the mean \pm 1 standard deviation. Each mean is based on 5 groups of 50 bees sampled from a different colony on each of 5 consecutive days.

Treatment (mw/cm ²)	Days Post-Treatment				
	1	6	11	16	21
3	23.4 \pm 5.4	15.4 \pm 2.4	13.8 \pm 2.2	11.0 \pm 3.7	9.2 \pm 2.6
sham	22.6 \pm 4.3	14.8 \pm 3.1	13.0 \pm 2.5	10.8 \pm 2.8	8.2 \pm 3.3
6	21.0 \pm 6.1	16.4 \pm 4.7	14.6 \pm 4.0	10.0 \pm 4.1	6.1 \pm 2.5
sham	26.2 \pm 5.7	16.4 \pm 3.8	12.6 \pm 2.0	12.4 \pm 3.3	9.2 \pm 4.0
9	20.4 \pm 3.8	15.4 \pm 2.2	14.2 \pm 1.9	12.4 \pm 2.9	9.4 \pm 2.3
sham	18.2 \pm 2.4	14.6 \pm 2.2	14.2 \pm 4.6	10.1 \pm 4.8	8.8 \pm 3.3
25	22.2 \pm 2.7	15.2 \pm 3.6	13.6 \pm 4.4	10.4 \pm 2.4	7.2 \pm 1.3
sham	20.4 \pm 3.7	15.8 \pm 2.8	15.6 \pm 3.7	9.0 \pm 2.6	9.4 \pm 3.7
50	23.8 \pm 4.5	18.2 \pm 3.9	13.8 \pm 1.9	9.0 \pm 3.3	6.4 \pm 1.5
sham	21.2 \pm 6.1	16.4 \pm 2.7	15.6 \pm 2.4	11.0 \pm 1.2	8.0 \pm 1.6
Control	20.8 \pm 4.4	14.8 \pm 3.2	11.4 \pm 4.4	10.4 \pm 3.7	6.8 \pm 2.4

Table 3.3 Number of multiple observations during each census of individually tagged bees in glass-walled observation hives following 30 minute exposures to 2.45 GHz continuous wave microwave radiation. Each value is the mean \pm 1 standard deviation. Each mean is based on 5 groups of 50 bees sampled from a different colony on each of 5 consecutive days.

Treatment (mw/cm ²)	Days Post- Treatment				
	1	6	11	16	21
3	4.8 \pm 1.5	2.4 \pm 2.0	1.4 \pm 1.1	1.8 \pm 1.65	0.8 \pm 1.8
sham	5.0 \pm 3.0	2.0 \pm 1.7	1.8 \pm 1.6	0.6 \pm 0.9	0.4 \pm 0.6
6	2.2 \pm 3.4	1.0 \pm 1.2	1.0 \pm 1.2	1.0 \pm 1.0	0.8 \pm 1.3
sham	6.6 \pm 2.3	1.2 \pm 1.1	1.4 \pm 1.7	0.8 \pm 0.8	1.8 \pm 1.5
9	5.4 \pm 2.6	0.8 \pm 1.1	1.6 \pm 2.2	2.2 \pm 1.1	0.8 \pm 0.8
sham	3.0 \pm 1.4	0.8 \pm 1.3	2.0 \pm 1.0	0.4 \pm 0.6	0.8 \pm 0.8
25	4.4 \pm 2.6	1.2 \pm 0.5	2.5 \pm 1.1	1.2 \pm 1.6	1.4 \pm 1.1
sham	6.2 \pm 2.4	1.8 \pm 1.5	1.8 \pm 1.3	0.4 \pm 0.9	0.6 \pm 1.3
50	5.6 \pm 2.6	2.0 \pm 1.0	2.0 \pm 1.4	1.2 \pm 1.1	0.6 \pm 0.6
sham	5.2 \pm 2.2	2.2 \pm 1.6	2.8 \pm 2.3	0.4 \pm 0.6	0.4 \pm 0.6
Control	5.4 \pm 1.8	1.2 \pm 1.3	1.0 \pm 1.2	1.0 \pm 1.0	0.8 \pm 0.8

the larger population of bees increased the time required per hive for the census (ca 30 min/hive on day 1, diminishing to ca 5 min on day 21), thereby increasing the opportunity for multiple recordings of mobile bees during any given census.

Morning and afternoon census data on 5 days post-exposure (1, 6, 11, 16, and 21) for (1) total number of bees observed, (2) the number of individual bees observed, and (3) the frequency of multiple observations were used for the following orthogonal comparisons: (1) corresponding microwave and sham exposure groups at each of the 5 treatment levels (2) corresponding exposure groups for morning and afternoon censuses, (3) the 5 microwave exposure levels grouped versus the 5 sham exposure levels, (4) the 5 sham exposure groups collectively versus the laboratory control group, and (5) the 5 microwave exposure groups collectively versus the laboratory control groups. No significant differences were found in any of these comparisons ($p = 0.10$).

Our data indicate that 30-min exposure of adult honey bees to 2.45 GHz continuous wave microwaves at selected power densities between 3-50 mw/cm^2 do not significantly affect the survival, longevity, or intra-colony mobility of honey bees.

ACKNOWLEDGEMENTS

This research was supported by the Department of Energy (Argonne National Laboratory contract numbers 31-109-38-4442 and 31-109-38-5066) and National Aeronautics and Space Administration (contract number NAS2-9539).

We thank J. Ali, (EPA-Research Triangle Park) and J. McGrath for engineering consultation; Shu Geng for statistical consultation; J. Brandon, S. Cobey, R. Ebadi, P. Harizanis, O. Kaftanoglu, M. Kurtz, K. Lorenzen, W. Marks, S. Molnar, and R. Page for assisting with the research.

REFERENCES CITED

- Altmann, G. and U. Warnke, 1976. Der stoffwechsel von bienen (Apis mellifica L.) im 50-Hz-Hochspannungsfeld. Z. ang. Ent. 80:2670271.
- Gary, H. E. and K. Lorenzen. 1976. How to construct and maintain an observation Bee Hive. Leaflet #2853. Div. of Agric. Sci., Univ. of Calif., Coop. Ext.
- Glaser, P. F. 1980. The earth benefits of solar power satellites. Space Solar Power Rev. 1:9-38.
- Greenberg, B., J. C. Eunich, and V. P. Bindokas. 1979. The Effects of High Voltage Transmission Lines on Honey Bees. Interim Rept., Elec. Power. Res. Inst. EA-341. Available from EPRI, Research Report Center, P.O. Box 50490, Palo Alto, CA 94303.
- Koomanoff, F. A. and C. A. Sandahl. 1980. Status of the satellite power system concept development and evaluation program. Space Solar Power Rev. 1:67-77.
- Newsom, B. D. 1978. Research plan for study of biological and ecological effects of the solar power satellite transmission system. NASA Contractor Report 3044, p. 144-202. Available from National Technical Information Service, Springfield, Virginia 22161.
- Paul, R. and U. Warnke. 1975. Das verhalten von bienevolkern unter hochspannungsleitungen, Biene. 111:63-9.

4 SURVIVAL, DEVELOPMENT AND TERATOLOGY OF HONEY BEE BROOD (Apis mellifera L.) .
FOLLOWING EXPOSURE TO 2.45 GHz CONTINUOUS WAVE RADIATION

BY

Becky B. Westerdahl and Norman E. Gary

Department of Entomology
University of California
Davis, CA 95616

ABSTRACT

Honey bee brood (1, 7, and 14 days old) in combs was exposed for 30 minutes to 2.45 GHz continuous wave microwave radiation at six power densities (0, 3, 6, 9, 25 and 50 mw/cm^2). No significant effects were observed concerning developmental rate or survival to adult emergence. Teratological effects were not detected.

Implementation of the Solar Power Satellite (SPS) system requires a careful assessment of environmental risks, including studies of the possible effects of microwave radiation on a broad spectrum of animal life. High priority has been assigned to the definition of possible effects on airborne biota that cannot be excluded from the rectennal areas where 2.45 GHz continuous wave microwaves (CWM) would be received continuously at approximately 23 mW/cm^2 at the rectenna center.

This study was conducted as part of an ongoing program to ascertain possible biological effects of CWM on invertebrates as part of the SPS Concept Development and Evaluation Program (1, 2). We wished to determine if short term exposures (30 min.) of the immature stages of honey bee eggs, larvae, and pupae to CWM at power level densities approximating those in the rectennal area would cause adverse mortality, growth, or teratological effects.

Insofar as we know this is the first study in which invertebrates have been exposed to continuous wave 2.45 microwave radiation, i.e., a ripple of $< 2\%$. Mahra et. al. (3) reviewed several studies in which developmental rate was altered after exposing immature stages of butterflies and beetles to 2.45 GHz. More recent research (4, 5) indicates that treatment levels of several hundred watts are lethal to immature stages of southern corn rootworm, Diabrotica undecimpunctata Howardi, cigarette beetles, Lasidderma serricorne, and tobacco moths, Ephestia eludella. Searle et. al. (6) found no significant effects on larvae of the fruit fly, Drosophila melanogaster, when exposed to power densities up to 1.0 W/cm^2 . Other studies (7) indicate that some microwave frequencies may induce teratogenesis in the darkling ground beetle, Tenebrio molitor.

In our research honey bees are being used because they are ideal experimental animals for studying the effects of CWM that are required in the current

SPS reference system and they are environmentally and economically significant as the major insect pollinator of wild flora and cultivated crops that account for 1/3 of the nations food supply (8).

Immature stages of honey bees are reared within nests which consist of multiple, vertically oriented beeswax combs composed of hexagonal cells. Eggs are laid singly in these cells at the rate of several hundred up to 2,000 daily, depending upon the season and colony population. Developmental times of the immature stages are remarkably uniform in the nearly constant incubation temperature of 33 - 35° C maintained by adult bees clustered over the comb surfaces. Eggs hatch three days after being laid, revealing a tiny larvae that is fed hundreds of times by nurse bees during 5 - 6 days of development until the cell is sealed with beeswax caps on the 8 - 9th day. Larvae pupate on the 11th day and adults emerge on approximately the 21st day.

Methods and Materials

This study was conducted as a 6 x 6 x 2 x 3 factorial with the factors being six queens, six treatment levels (0, 3, 6, 9, 25 and 50 mw/cm²), two exposure chambers (microwave and sham) and three stages of brood that were one (eggs), seven (larvae) and 14 (pupae) days old. To assure genetic variability, eggs were obtained from six queens chosen at random. A 6 x 6 Latin Square treatment design assured that treatments would be performed in a different order each day and that brood from each of the six queens would be exposed to all six treatment levels during the six day period when exposure treatments were made. Concurrently with the microwave exposures, brood from the same queens was exposed in a sham treatment chamber, adjacent to and identical in construction to the microwave chamber, which received effluent air vented from the microwave treatment chamber. A total of 216 frames of brood were used during the study. All exposures were 30 minutes in duration.

New brood combs were generated for this study by attaching beeswax comb foundation in small frames (Fig. 1) made of nonmetallic materials, then inserted in standard honey bee colonies until comb construction was completed. Eggs of known age were obtained by confining each queen on two frames of comb within a chamber (14 x 12 x 16 cm) made of queen excluder material with openings which permitted the smaller worker bees to pass freely through the chamber walls while retaining the larger queen within. This chamber was placed in the center of the colony brood nest. Frames of comb containing eggs were replaced each day with empty combs. Distribution of eggs within the cells was controlled in part by temporarily covering the upper portion of each frame with 8 mesh screen wire to prevent access by the queen, thereby concentrating egg laying activities in the lower open cells. This procedure yielded two essentially identical combs of eggs, both genetically and structurally, from each queen on a daily basis. To obtain the 216 frames of brood needed for the study, queens in six colonies were confined to two frames of comb per day for 18 days. Because of daily fluctuations in egg laying of queens, three additional queens were confined so that combs of eggs would be available for substitution whenever any one of the six primary queens failed to fill two frames of comb with eggs on a particular day. When frames were placed in the queen chamber they were assigned randomly to either microwave or sham exposure groups and to an exposure level based on the Latin Square design. As frames of eggs were removed from the queen chambers they were transferred temporarily to a walk-in incubator held at 34° C and 60% relative humidity (normal brood nest conditions) until the distribution of eggs in cells could be recorded. This was accomplished by placing a transparent acetate sheet over the cells, and by placing color-coded dots on the acetate surface over each cell with felt tip marking pens (Sharpie). Such recordings were made at selected critical developmental times, viz., on the first, second,

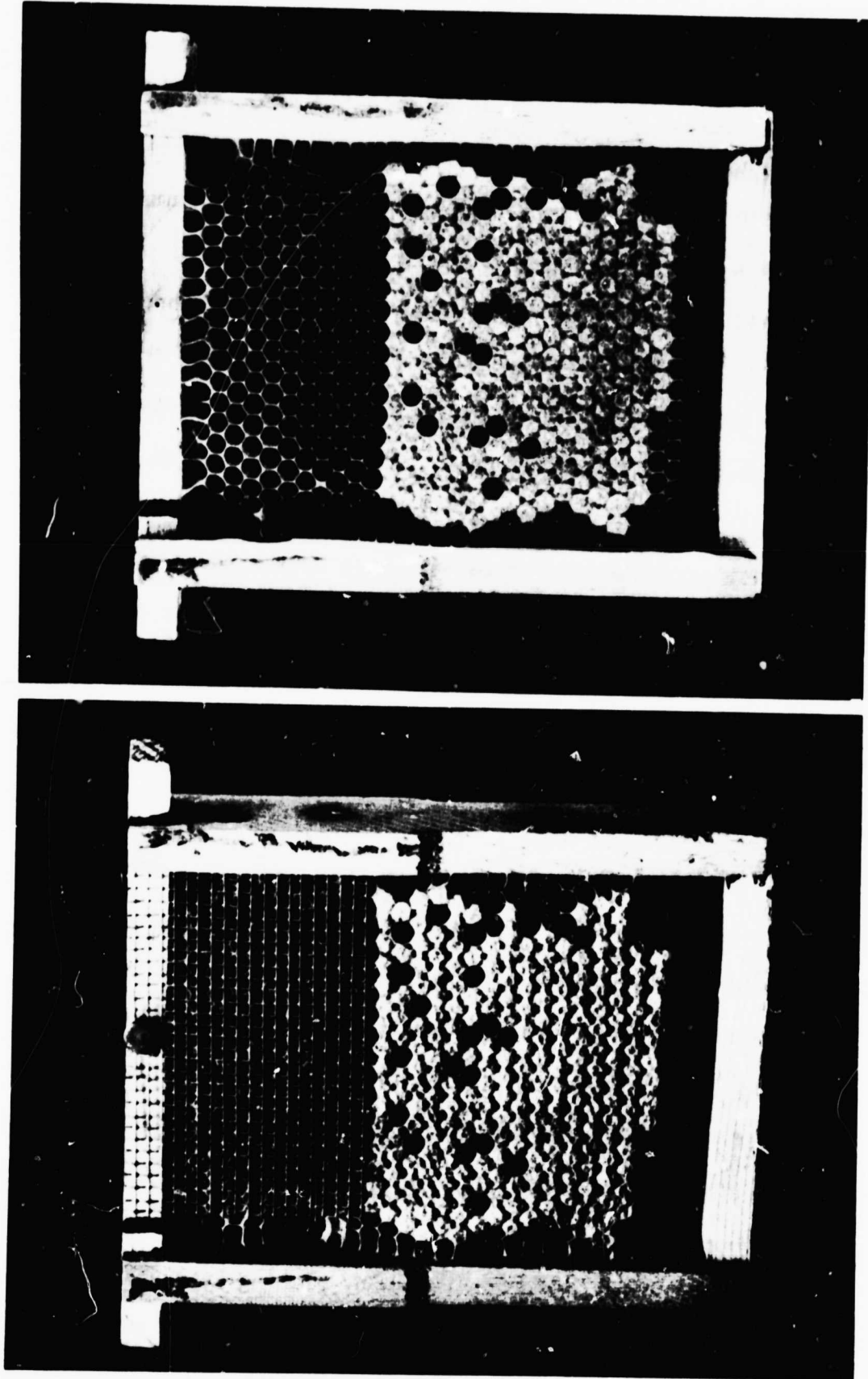

Figure 4.1 Brood comb frames showing distribution of capped brood cells in the comb. The 8-mesh wire screen (left) prevented egg-laying by the queen in the upper area, thereby concentrating brood in the lower area to facilitate the census. The wire screen was removed (right) after egg-laying and before microwave exposure

tenth and twenty-fourth days after the eggs were laid. An additional recording of larval survival was made on the seventh day of development for brood combs that were in the larval stage at the time of treatment.

Brood for all treatments and shams was maintained in populous nursery colonies in a queen-free compartment under identical conditions until it reached the capped stage and no longer required care by nurse bees. Then the brood was transferred to an incubator at 34° C and 60% relative humidity where comb frames were placed in individual cages to retain adult bees at emergence time. Approximately 95% of the adult bees generated by the eggs laid on any given day normally emerge as adult bees during a three day period (21-23 days after the eggs were laid). During a four day period (21st to 24th days) the emerged bees were brushed daily from the frames into polyethylene bags and frozen for later population counts and examination for teratological effects. Cells containing brood which did not emerge by the 24th day were uncapped and the degree of development recorded. Bees that had reached the pupal stage were preserved in 95% ethanol for later examination.

During all handling procedures care was exercised not to injure brood by jarring the frame. For example, bees were removed from combs by brushing rather than shaking the frame. Scheduling of all operations was such that, beginning on the 13th day after the queens were confined, and continuing until the 18th day, 12 combs per day of each of the three ages of brood (eggs, larvae, and pupae) were available for the exposures at each of the six microwave and sham treatments.

Microwave radiation used during the exposures was generated by a 2.45 GHz continuous wave power supply unit capable of generating up to 300 watts of power with a < 2 percent ripple. Waveguides transmitted the power to a Narda 644 horn antenna mounted into the top of a rectangular exposure chamber

(61 cm long and 61 cm wide). Walls of the chamber were lined with Eccosorb HT-99 (Emerson and Cuming). The base of the horn was 121 cm above the 61 x 61 styrofoam treatment platform.

Power entering the chamber was monitored continuously with a 3oonton 41-4A detector. Periodically a crystal detector (Hewlett-Packard) was substituted for the power detector to check the wave-form from the power supply. Exposures using 25 and 50 mw/cm² utilized the waveguide system whereas the lower power levels were produced by adding an attenuator.

Frames of comb were held in the normal vertical orientation on the treatment platform during exposures. During treatment normal brood nest temperatures were supplied to both chambers. Temperatures within the microwave and sham chambers were measured with liquid crystal thermometer strips (American Thermometer Company) located on the treatment platform and recorded at the beginning and end of each exposure period. Atmosphere within the treatment chamber was removed by fans (Pamoter model 7606), which was conducted through an insulated duct to the sham chamber that was vented by fans through a duct to exhaust the air outside the laboratory. Thus, any odors in the treatment chamber, including possible pheromones released by the bees, were present in the sham chamber too.

RESULTS AND DISCUSSION

Data on the survival of treated eggs are presented in Table 1. The general trend for decreasing survival with increasing age is typical for the late summer season when the study was conducted. The survival of a control group of brood that was reared within a nursery colony and never exposed within either chamber was 58.7%. Orthogonal comparisons (conducted following an inverse sign transformation of the data) indicated no significant differences (0.10 level) between (1) microwave and sham exposures at any

Table 4.1 Post-treatment survival of honey bee eggs following 30-minute exposures to six levels of 2.45 GHz continuous wave radiation

Power Density (mw/cm ²)	Egg Survival (%)					
	1 Day Post-Treatment		10 Days Post-Treatment		20 Day Post-Treatment (adult emergence)	
	<u>mean</u>	<u>S.D.</u> ²	<u>mean</u>	<u>S.D.</u>	<u>mean</u>	<u>S.D.</u>
0	86.3 ^b	3.7	51.1	18.9	50.7	18.8
sham	87.8	4.5	74.7	2.0	74.5	1.9
3	62.4	17.9	32.3	25.5	31.4	25.5
sham	67.7	20.9	37.3	11.2	35.7	12.0
6	88.7	10.9	44.9	19.4	44.5	18.0
sham	77.9	23.9	49.4	19.9	49.0	19.9
9	92.2	9.9	43.0	17.4	42.6	17.4
sham	76.9	26.6	48.2	33.2	46.7	32.3
25	80.4	5.7	38.9	16.4	37.5	15.4
sham	67.8	10.7	49.9	13.7	37.9	20.1
50	85.6	6.0	46.5	18.5	45.6	18.0
sham	80.2	13.9	48.6	16.2	47.1	17.4

^a Means and Standard Deviations (S.D.) have been transformed back to the original scale following an inverse sign transformation for data analysis.

^b Each point is the mean brood survival for a total of 6 replications conducted over a 6 day period on brood produced by a different queen each day as determined by a Latin square design utilizing the 6 queens and treatment levels during 6 consecutive days. One queen produced the brood for corresponding microwave and sham exposures for a particular day.

power density that was tested, (2) between exposures conducted within the microwave and sham chambers for all six levels grouped for each chamber, (3) between the combined microwave (3, 6, 9, 25 and 50 mw/cm^2) and sham exposures when the five microwave treatment levels were combined, or (4) between the zero level exposures compared with all other exposure levels combined.

The consistently lower level of survival in the microwave exposure groups at 10 and 20 days post-treatment may be accounted for as follows. Slightly higher brood mortality was observed in the bottom chamber of nursery colonies throughout the study. This effect should have been distributed equally between brood groups, according to our experimental design, by alternating the placement of treated and sham groups in top and bottom colony chambers. However, in the egg treatment group, the microwave-treated frames were placed inadvertently in the bottom chamber four times rather than the usual three, thereby causing higher survival of sham groups.

Larval and pupal survival following microwave treatment are shown in Tables 2 and 3, respectively. Higher levels of post-treatment survival of these stages, compared to eggs, is not unusual. Most natural mortality occurs prior to the seventh day of development from such causes as low viability or cannibalism. Orthogonal comparisons corresponding to those conducted for the egg stage indicated no significant differences (0.10 level).

Emergence of adult bees for all treatment groups occurred during the normal time span and no teratological effects were detected in either the emerged adults or unemerged pupae that died prior to emergence.

Overall, no statistically significant differences were found in this study for any of the treatments. We conclude that short term exposures of 2.45 GHz continuous wave microwaves between three and 50 mw/cm^2 have no apparent effect on the immature stages of the honey bee.

Table 4.2 Post-treatment survival of honey bee larvae following 30-minute exposures to six levels of 2.45 GHz continuous wave radiation

Power Density (mw/cm ²)	<u>Larval Survival (%)</u>			
	3 Days Post-Treatment		14 Days Post-Treatment (adult emergence)	
	<u>mean</u>	<u>S.D.</u> ²	<u>mean</u>	<u>S.D.</u>
0	80.1 ^b	27.7	78.2	26.6
sham	86.9	2.7	83.1	2.2
3	93.2	8.8	91.8	8.9
sham	81.9	8.9	85.3	13.7
6	76.6	31.1	76.0	28.9
sham	96.1	2.6	95.3	2.2
9	78.0	27.7	76.7	26.8
sham	81.2	28.6	77.3	26.0
25	91.2	7.5	86.8	9.6
sham	86.0	6.9	83.1	6.4
50	83.3	4.8	80.6	5.0
sham	82.1	28.3	79.6	27.0

a See Table 1 footnotes.

b See Table 1 footnotes.

Table 4.3 Post-treatment survival of honey bee pupae following 30-minute exposures to six levels of 2.45 GHz continuous wave radiation

Power Density (mw/cm ²)	Pupal Survival (%)	
	7 Days Post-Treatment (adult emergence)	
	<u>mean</u>	<u>S.D.</u>
0	98.3 ^b	0.4
sham	90.3	16.4
3	92.6	19.5
sham	98.1	2.1
6	98.0	2.5
sham	91.2	14.2
9	99.4	0.5
sham	95.1	2.6
25	99.0	0.8
sham	94.8	4.1
50	88.5	32.2
sham	91.5	4.9

a See Table 1 footnotes.

b See Table 1 footnotes.

ACKNOWLEDGEMENTS

This research was supported by the Department of Energy through Argonne National Laboratory (contract numbers 31-109-38-4442 and 31-109-38-5066) and the National Aeronautics and Space Administration (contract number NAS2-9539).

We thank J. Ali (EPA-Research Triangle Park) and J. McGrath (U.C. Davis) for engineering consultation; Shu Geng (U.C. Davis) for statistical consultation; S. Cobey, O. Kaftanoglu, K. Lorenzen, S. Molnar and R. Page (U.C. Davis) for assisting with the research.

REFERENCES

1. B. D. Newsom, Research Plan for Study of Biological and Ecological Effects of the Solar Power Satellite Transmission System, NASA Contractor Report 3044 (1978).
2. F. A. Koomanoff and C. A. Sandahl, Status of the Satellite Power System Concept Development and Evaluation Program, Space Solar Power Rev. 1, 67-77 (1980).
3. K. Marha, J. Musil and H. Tuhà, Electromagnetic Fields and the Life Environment, San Francisco Press, Inc., San Francisco, CA (1971).
4. G.E. Fanslow, J. J. Tollefson, and J. C. Owens, Ovicidal Levels of 2.45 GHz Electromagnetic Energy for the Southern Corn Rootworm, J. Microwave Power 10, 321-325 (1975).
5. T. Hirose, I. Abe, M. Kohno, T. Suzuki, K. Oshima, and T. Okakura, The Use of Microwave Heating to Control Insects in Cigarette Manufacture, J. Microwave Power 10, 181-190 (1975).
6. G. W. Searle, R. W. Dahlen, C. J. Imig, C. C. Wunder, J. D. Thomson, J. A. Thomas, and W. J. Moressi, Effects of 2450 Microwaves in Dogs, Rats and Larvae of the Common Fruit Fly, in Proc. 4th Annu. Tri-Service Conf. Biol. Effects of Microwave Radiating Equipments: Biological Effects of Microwave Radiation, (1960).
7. R. D. Phillips, et. al., Compilation and Assessment of Microwave Bioeffects, Final Report: A Selective Review of the Literature on Biological Effects of Microwaves in Relation to the Satellite Power System (SPS), May 1978. PNL-2634 (rev.).
8. McGregor, S. E., Insect Pollination of Cultivated Crop Plants, USDA Agric. Handbook No. 496, (1976).

5 Chronic Exposure of a Honey Bee Colony to 2.45 GHz
Continuous Wave Microwaves

by

Becky Brown Westerdahl and Norman E. Gary

Department of Entomology

University of California

Davis, CA 95616

ABSTRACT

A honey bee colony (Anis mellifera L.) was exposed 28 days to 2.45 GHz continuous wave microwaves at a power density (1 mw/cm^2) expected to be associated with rectennae in the Solar Power Satellite Power Transmission system. There were no significant differences found between the sham and microwave-treated colonies regarding (1) flight and pollen foraging activity, (2) maintenance of internal colony temperature, (3) brood rearing activity, (4) food collection and storage, (5) colony weight, and (6) adult populations.

INTRODUCTION

An alternative energy system has been proposed in which Solar Power Satellites (SPS) would operate in geosynchronous orbit above the United States to collect solar energy and to transmit it to earth via 2.45 GHz continuous wave microwave beams (1). This system has great potential for economically producing vast quantities of energy with minimal environmental impact, compared to other alternative energy systems. A single satellite would produce 5 gigawatts of electricity. An economic model (2) indicates that if all factors are taken into consideration (including the cost of fuel to construct and operate the system) the SPS system might produce electrical energy at a competitive cost with other emerging energy technologies.

Even though the SPS system has great potential and appears feasible from both engineering and economic standpoints, a major concern by the general public is the possibility of adverse biological effects of microwave radiation on animals and plants living within and around the ground-based microwave receiving antennae (rectennae) where power densities would range from 23 mW/cm^2 at the center to ca 1 mW/cm^2 near the edge (3). Airborne biota are an important part of the environment. For example, invertebrate species such as insects interact with plants, higher animals, and physical environmental factors in complex ways that are not always anticipated. Even though current engineering models predict that organisms which are considerably smaller than the size of the wavelength (12.5 cm) will be essentially "invisible" to microwaves, and therefore not be affected, it is essential to conduct thorough investigations on biological effects prior to large scale

commitments to development of the SPS system. Even if biological effects are not found, such studies would provide valuable evidence for validating and refining engineering models for invertebrates and higher animals.

Because it is impossible to study all of the more than one million species of invertebrates, experiments should be conducted on representative species. A previous report (4) lists criteria by which invertebrates are prioritized for study and describes experiments essential to provide an overview of possible effects of SPS frequency microwaves on invertebrates. The honey bee has been chosen for initial studies because: (1) it is a flying invertebrate, thereby representing airborne invertebrates that cannot be excluded from rectennae, (2) it has a short life cycle so that many generations can be rapidly studied in a short time, (3) it has highly stereotyped behavioral patterns that can be quantified easily as an index of normal health, (4) it is known to be sensitive to some forms of electromagnetic energy, and (5) it is economically important because it is required to pollinate ca one-third of the food produced in the United States.

A honey bee colony nest is composed of vertically oriented beeswax combs containing numerous cells used interchangeably for rearing young (brood) and storing food (pollen and honey). One reproductive female (queen) lays eggs in the comb cells. Non-reproductive females (workers) perform many other functions such as brood rearing, food collection and processing, and temperature control ($34^{\circ} \pm 2^{\circ} \text{C}$) in the brood area. Immature bees have distinct developmental stages of predictable duration. For example, 3 days after oviposition the eggs hatch, yielding larvae that develop rapidly until they are sealed in their cells with beeswax

caps on the 8th day of development. Larvae pupate on the 11th day and emerge on the 20th-21st day as adult worker bees.

This report describes the behavior and brood development of an entire colony of honey bees during chronic exposure to microwave radiation at an exposure level (1 mw/cm^2) anticipated near the edge of a rectenna. The exposure period (28 days) exceeds that required for the completion of one cycle of brood, thus exposing all developmental stages to microwave treatment.

METHODS AND MATERIALS

The microwave power supply and anechoic chambers utilized for this study were designed and constructed to simulate conditions anticipated within and surrounding the SPS rectennae. Power was conveyed from the 2.45 GHz continuous wave power supply (ripple < 2%) through waveguides to a 10 dB fixed attenuator (Omega model 922X1) and 0 to 40 dB variable attenuator (Omega model 162) into a Narda standard gain horn (model 644) oriented vertically at the top of the anechoic chamber. A Boonton power detector (model 41-4A) connected to a 50 dB cross guide coupler (Arra model 284-602-50-n) and to a Data Precision digital multimeter (model 1350) provided a continuous readout of power levels within the microwave exposure chamber. The power detector was calibrated with a Narda microwave meter (model 8611) and probe (model 8623) which had been calibrated against a custom-built three element orthogonal dipole probe (supplied by Environmental Protection Agency, Research Triangle Park) which was in turn calibrated against a reference probe at the U.S. National Bureau of Standards.

Anechoic chambers (Fig. 1) used in this study were essentially

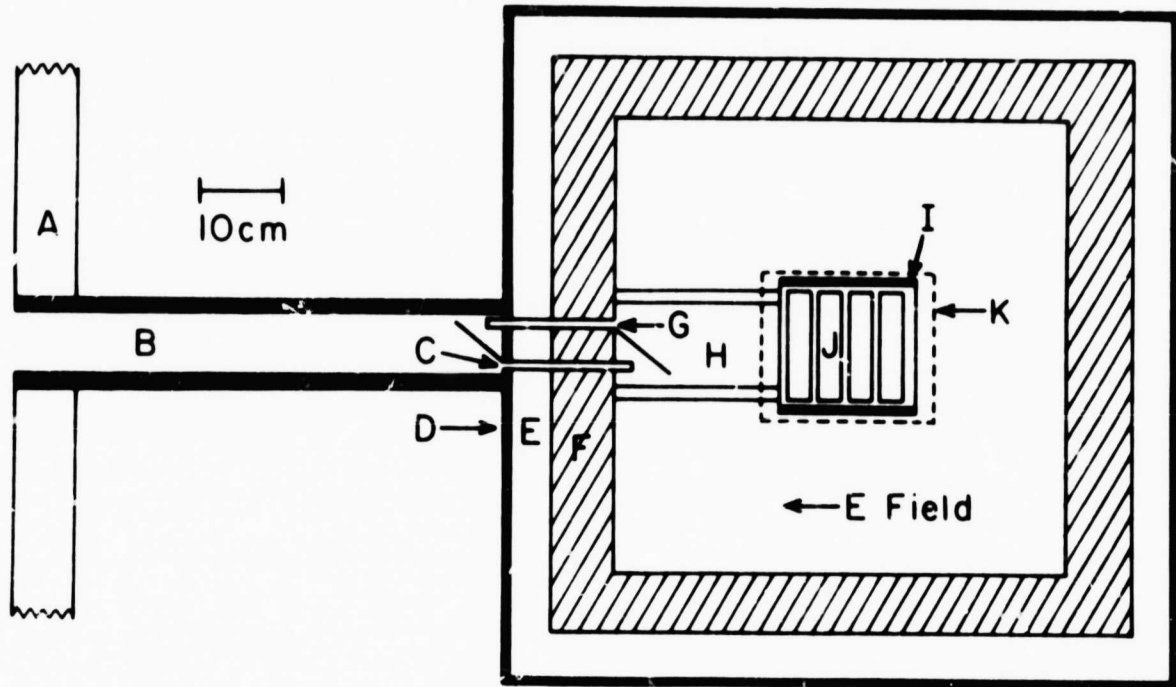

Figure 5.1 Cross section of anechoic chamber showing colony and runway system that permitted bees to forage outdoors during chronic exposure. (A) laboratory wall, (B) observation runway within laboratory, (C) anechoic chamber entrance tube, (D) exterior plywood and aluminum wall of chamber, (E) vented air space, (F) internal chamber wall constructed of microwave absorbing material, (G) anechoic chamber exit tube, (H) styrofoam runway inside anechoic chamber, (I) exterior wall of hive, (J) frames of beeswax comb within colony, (K) outline of hive cover

rectangular plywood boxes (88 X 88 X 196 cm) lined with aluminum sheeting. A second interior box was constructed of microwave absorbing material (Emerson and Cuming HT-99 ceramic absorber for the walls and ceiling and SPY-12 pyramidal rubberized absorber for the floor) and separated from the outer box by a vented air space. A styrofoam exposure platform (61 X 61 cm) was situated above the pyramidal absorber and located 121 cm from the horn. Two identical anechoic chambers for sham and microwave exposures, respectively, were situated side by side, 46 cm apart. Because of the low power level utilized in this study, passive cooling of the chambers provided adequate temperature control.

The sham and treatment hives (Fig. 2) were 18 X 18 X 22 cm boxes constructed of nonmetallic materials. The sides and removable top were made of pine (2 cm thick); the front and back were made of box shuck (0.64 cm thick). Hives were assembled with glue (Weldwood Resorcinol water proof). Each hive was ventilated through a front entrance-exit hole and a back ventilation hole (both 3 cm dia.), the latter covered with fiberglass screen. During the exposure period, each colony contained 4 beeswax combs (10 X 3 X 14 cm) in wooden frames that were parallel to the front wall of the hive.

A runway system (Fig. 1) connected each hive to a separate exit hole leading to the outside and permitted bees to enter and exit freely, thereby providing the opportunity for normal foraging activities. Extending from the hive entrance to the chamber wall was a styrofoam runway (21 X 15 X 5 cm) (Fig. 1, H) covered with fiberglass screen. This runway and the hive rested on a piece of 0.64 cm thick plywood (41 X 20 cm) on top of the styrofoam exposure platform. Two plexiglas®

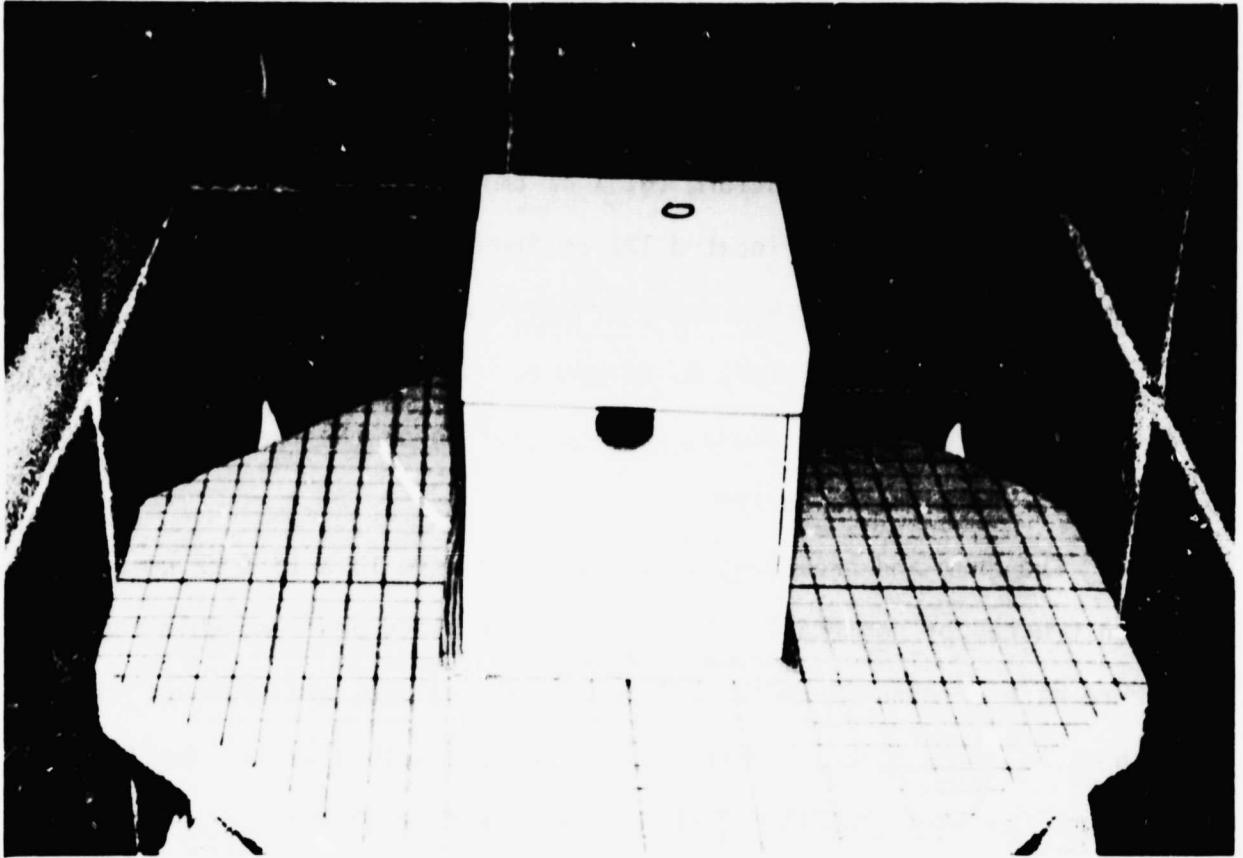

Figure 5.2 Interior view of hive inside anechoic chamber, showing screened ventilation hole in hive back

tubes (15 cm long, 0.95 cm I.D. and 1.3 cm O. D.) extended from the styrofoam runway inside the chamber through the chamber wall into the exterior wooden runway. Because of the small diameter of the tubes, chosen to minimize microwave leakage from the chambers, cardboard partitions (13 cm long) were placed in the runways at an angle to guide bees into either an exit tube or an entrance tube to prevent crowding that would have occurred if bees had been required to enter and exit through the same tube. A second runway (58 X 13 X 2.54 m) (Fig. 1, B), with sides and bottom constructed of wood and the top covered with glass, extended from the exterior chamber wall through the exterior wall of the laboratory.

The following parameters of colony biology were compared in the sham and treatment colonies: (1) flight and pollen foraging activity, (2) maintenance of internal brood nest temperature, (3) brood rearing activity, (4) distribution pattern of brood and food in cells within the combs (5) changes in colony weight, and (6) adult population at the end of the 28 day exposure period.

Nine days before microwave exposure was initiated, each hive was stocked with ca 2,000 worker bees, randomly sampled from a common hive 10 km from the laboratory, and placed onto 3 comb frames (1 honey, 1 with 1-day-old eggs, and 1 of 14-day-old capped brood). A laying queen also was introduced into each colony. To reduce genetic variation as much as possible, the introduced queens, as well as the queen that produced the brood and bees used for stocking the colonies, were all reared from eggs laid by the same queen mother.

Five days prior to microwave exposure, base line data on daily flight activity, as well as temperature within the colonies and

anechoic chambers, were taken to verify that both colonies and chambers were equivalent prior to the onset of exposure. Just prior to initiation of the exposure, (1) the comb of honey that had been placed in each hive was replaced with a full comb of honey to insure adequate food reserves for the duration of exposure, (2) 1 empty comb was added to each hive to stimulate egg laying, (3) both hives were weighed, (4) the number and distribution of food and brood in all combs were recorded. Then the 4 frames of comb in each hive were arranged from front (entrance end) to back as follows: (1) comb of brood from eggs laid 20 days prior to start of exposure, (2) empty comb, (3) comb of brood from eggs laid 9 days prior to start of exposure, and (4) comb of honey.

Power was turned on at 1000 hrs and remained on continuously for 28 days, except for 4-hour periods on days 7, 14, and 21 when the hives had to be removed from the chambers for weighing and recording of cell contents.

Daily flight and foraging activity were determined by recording the number of foraging bees returning to each hive, and the number of foraging bees that were carrying pollen (with the exceptions of days 7, 14, and 21). These observations were conducted during a one-hour period between 1100 and 1200 hrs by an observer who counted incoming bees during alternating 4 minute periods in each runway, separated by a 1 minute rest period, making a total of 6 observation periods per hive during the 1 hour interval.

Internal colony brood nests and ambient temperatures in the microwave anechoic chamber were measured continuously (except for days 13-16 when the monitoring unit malfunctioned, and during the 4-hour examinations of days 7, 14, and 21) with a gallium-arsenide fiberoptic

temperature monitoring unit (5) and recorded on an Omniscribe chart recorder (model B5237-5). Colony brood nest and ambient temperatures in the sham chamber were monitored continuously with copper-constantan thermocouples (Omega models SCPSS-020E-6 and SCPSS-062E-6, respectively), connected to electronic ice point references (Omega model MCJ-T), and recorded with an Omniscribe chart recorder (except on days 9-10 and 21-23 because of equipment malfunction).

Humidity was monitored continuously with a recording hygrothermograph (Bendix model 594) located inside the sham chamber. Ambient temperature and humidity inside the laboratory which housed the chambers was also monitored with a hygrothermograph.

At the end of each week of exposure (days 1, 7, 14, 21, and 28), both colonies were removed from the anechoic chambers and placed outside the laboratory in front of their respective entrance runways (to receive returning foragers) for 4-hour periods to permit comb examinations. Single frames of comb were removed alternately between microwave and sham colonies at ca 20 min intervals, brushed free of bees, then taken to an incubator room (34° C and 50% R.H.) where the contents of all cells were mapped on a clear acetate sheet affixed over the comb. Contents were discriminated by different color dots placed on the sheet with a felt tip marking pen (Sharpie) to denote eggs, larvae, capped brood, honey and nectar, pollen, or empty cells. Frames of comb were returned immediately to their respective colonies after examination, and microwave exposure was resumed immediately after the comb examinations were completed.

Each colony (including the plywood base) was weighed on days 1, 14, 21, and 28 of the study by a platform balance.

On the final day of the experiment, adult populations in each colony were estimated by removing all bees and placing them into a preweighed container to obtain the total weight. Then 5 subsamples of 40 bees were weighed to generate a mean weight that was used to extrapolate the total population.

RESULTS AND DISCUSSION

The total number of bees entering the colonies during the daily 24-min sampling intervals, as well as the number of these bees carrying pollen, are shown in Figs. 3 and 4, respectively. Both flight and pollen foraging activity appear to be closely correlated throughout the 28 day exposure period. The slight difference between microwave and sham colony foraging activity near the end of the study could be associated with an increased adult population in the microwave colony or a greater amount of uncapped brood that may stimulate foraging by more bees. There is no indication of microwave-induced effects in the treated colony.

The brood nest temperature of a honey bee colony is essentially independent of ambient temperature and is maintained at $34 \pm 2^\circ$ C. If ambient temperature levels are lower, bees produce heat by increased metabolic activity. If warmer, they cool the nest by distributing collected water within the nest and fanning, which causes evaporative cooling. Daily maximum and minimum temperatures within the brood nests of the sham and treated colonies are shown in Fig. 5. In both colonies there was a diurnal temperature cycle in which minimum and maximum nest temperatures occurred at ca 0300 and 1700 hrs, respectively. Minimum and maximum humidities in the laboratory and inside the sham chamber were 50-60 and 52- 62% R.H., respectively. Temperatures

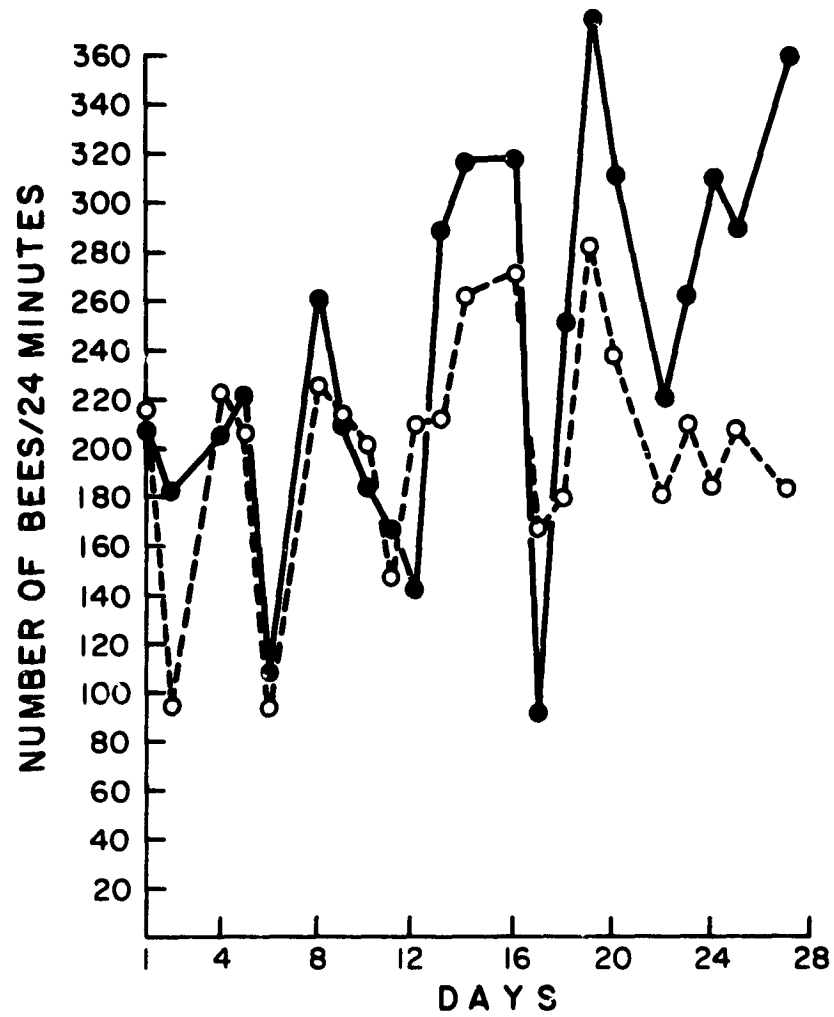

Figure 5.3 Daily foraging activity, expressed as numbers of bees entering the chamber, during chronic exposure of microwave (●) and sham (○) colonies. Each point represents six 4-minute observations within one hour

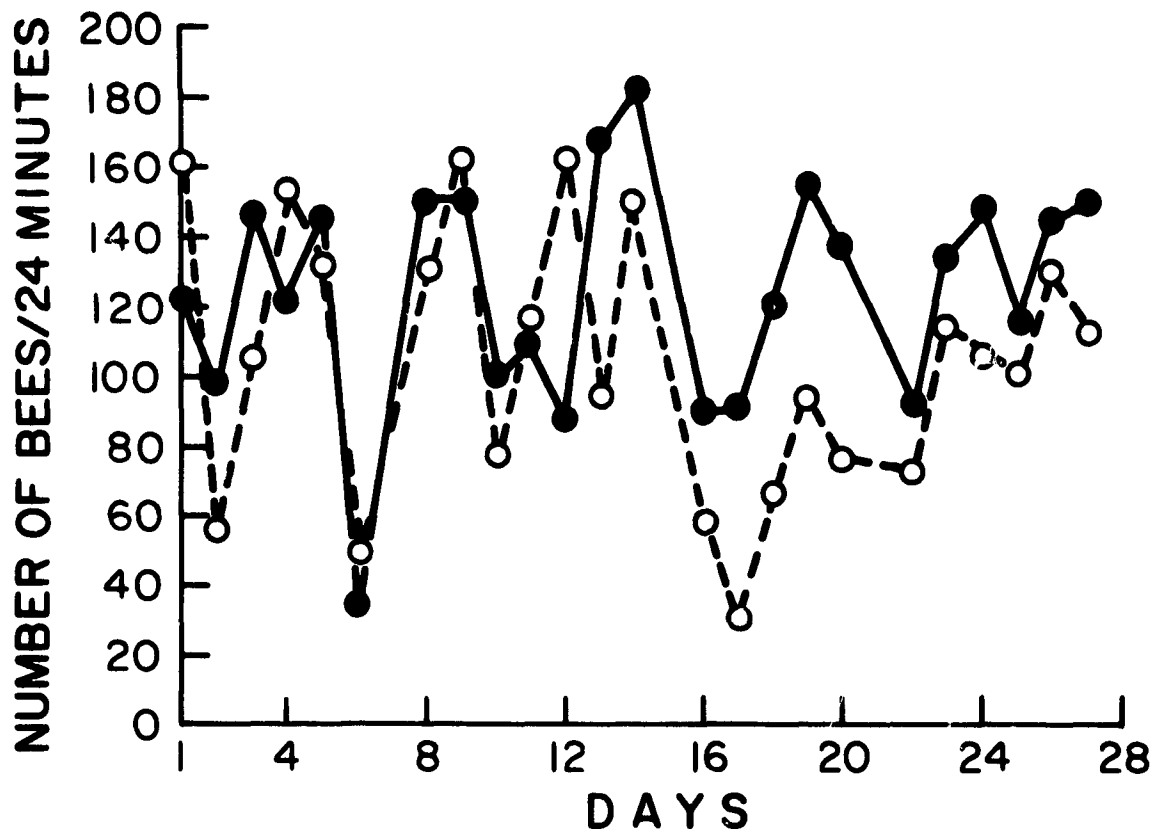

Figure 5.4 Daily pollen foraging activity, expressed as numbers of bees carrying pollen loads that entered the chamber, during chronic exposure of microwave (●) and sham (○) colonies. Each point represents six 4-minute observations within one hour

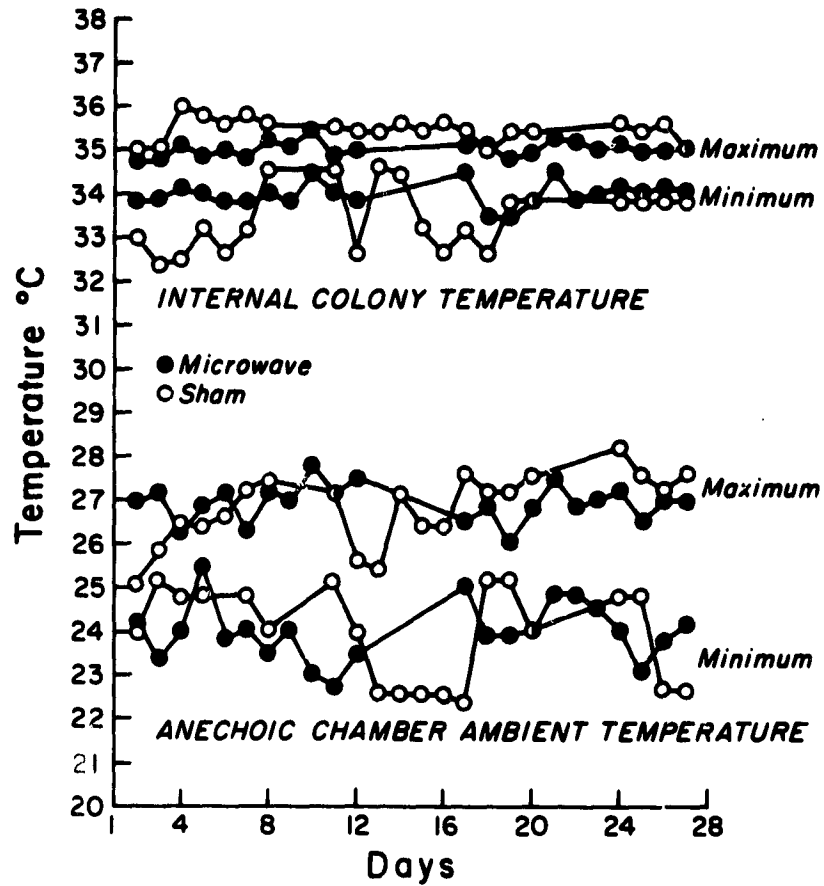

Figure 5.5 Daily maximum and minimum temperatures within brood nest inside hives within microwave (●) and sham (○) anechoic chambers during chronic exposure

and humidities within both colonies fall within the normal range, indicating no effects caused by the microwave treatment.

The total number of comb cells available in the 4 combs of each colony was 3,895 and 3,855 for the microwave-treated and sham colonies, respectively. At the beginning of the study both colonies contained essentially equal numbers of cells of eggs, larvae, capped brood, honey or nectar, pollen, and empty cells (Figures 6-11, respectively). At the end of the first week, the microwave colony contained fewer eggs, more larvae, and essentially the same number of capped cells, indicating that the queen in the microwave colony initiated oviposition earlier than the sham chamber queen after the empty comb was placed in each colony on the first day of exposure. Thereafter, through the end of the third week, the data indicate normal brood development in both colonies. By the end of the 4th week, the microwave-treated colony contained fewer eggs than the sham but more larvae and capped brood. This indicates that eggs laid by the queen in the sham colony were being cannibalized, a common occurrence during the late summer when brood rearing normally is reduced. The variation between the brood rearing activities of the two colonies was within the normal range of variation experienced in nature.

Honey and nectar in the combs diminished during the first week of the study and stabilized during the remainder of the exposure. This indicated that the bees were consuming nectar at the rate it was being gathered. Even though ca 50% of the foraging bees in both colonies were collecting pollen, the quantity of stored pollen remained low throughout the study in both colonies. Almost all of the pollen was being consumed during brood rearing activities.

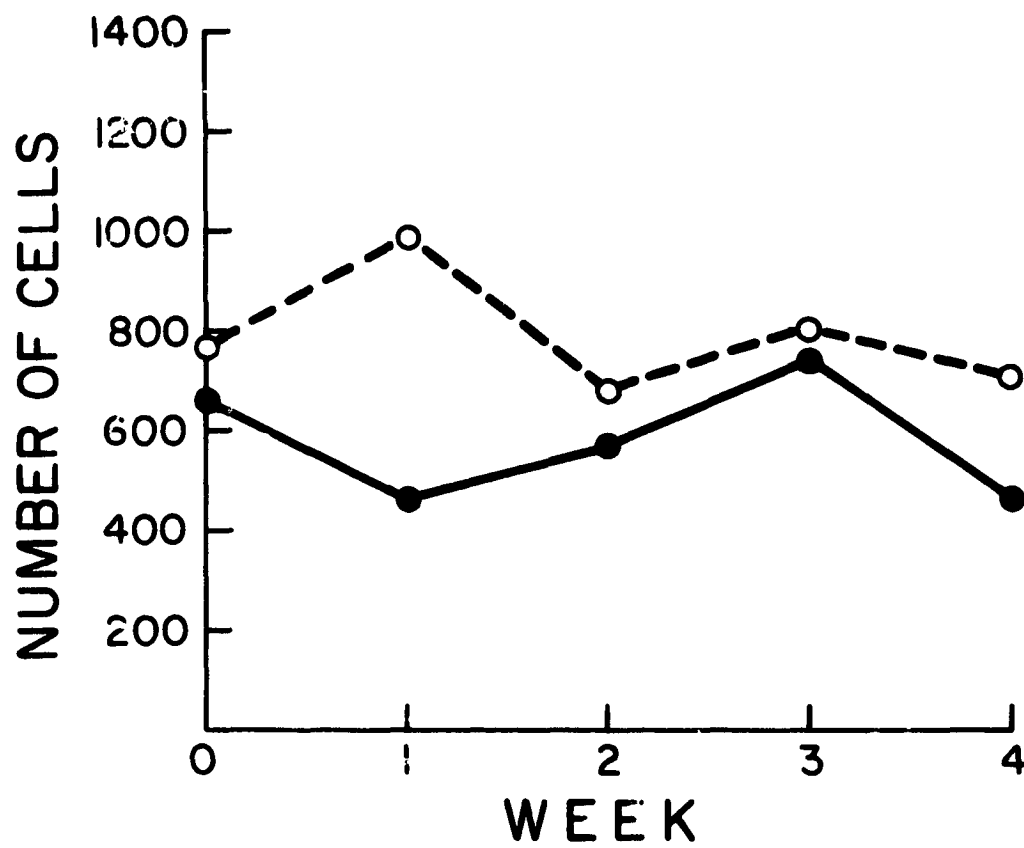

Figure 5.6 Number of cells containing eggs in microwave (●) and sham (○) chamber colonies during chronic exposure

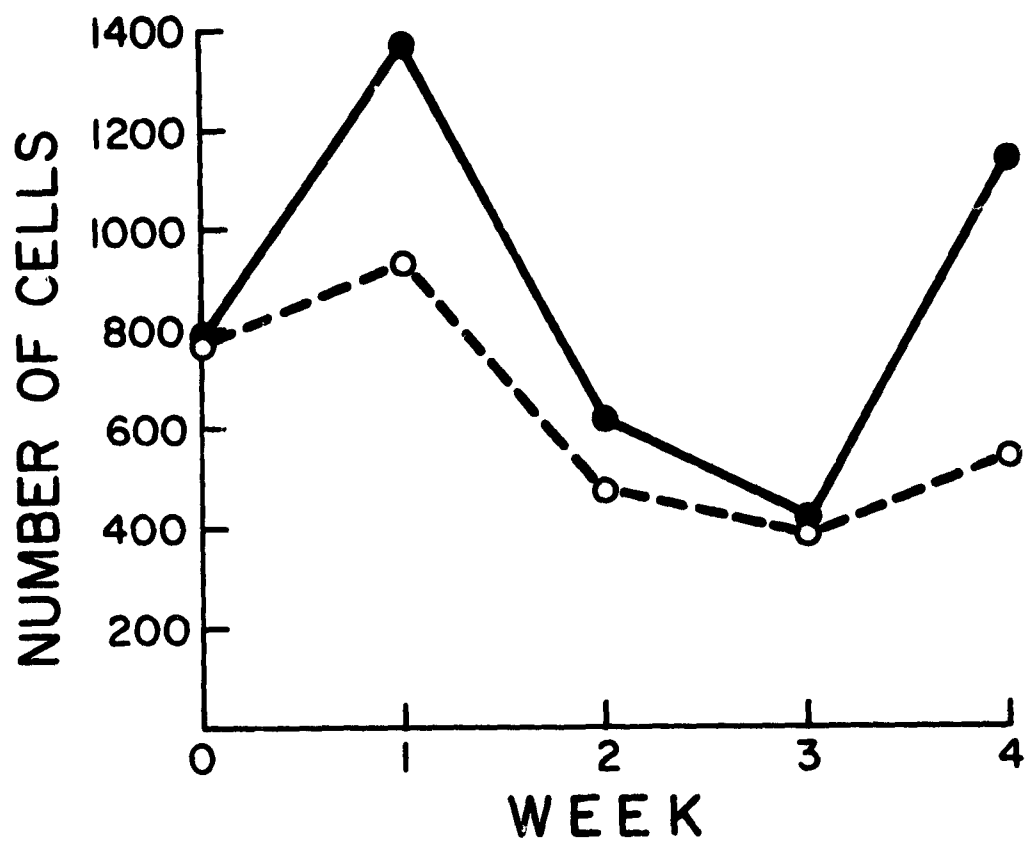

Figure 5.7 Number of cells containing larvae in microwave (●) and sham (○) chamber colonies during chronic exposure

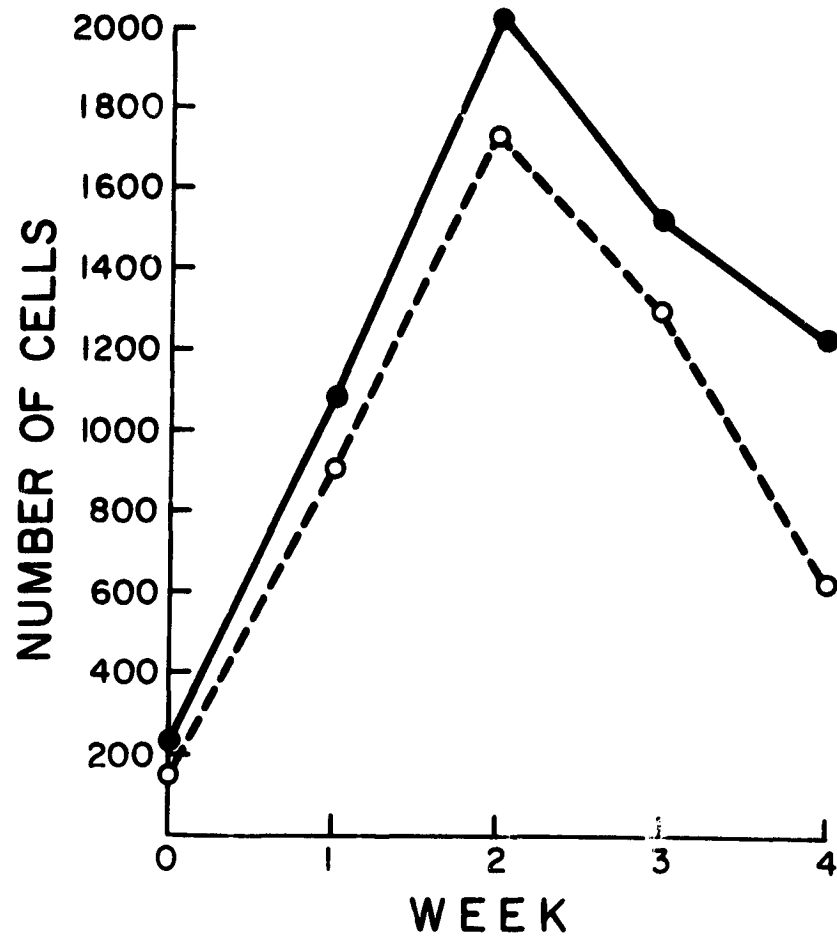

Figure 5.8 Number of cells containing copper; brood in microwave (●) and sham (○) chamber colonies during chronic exposure

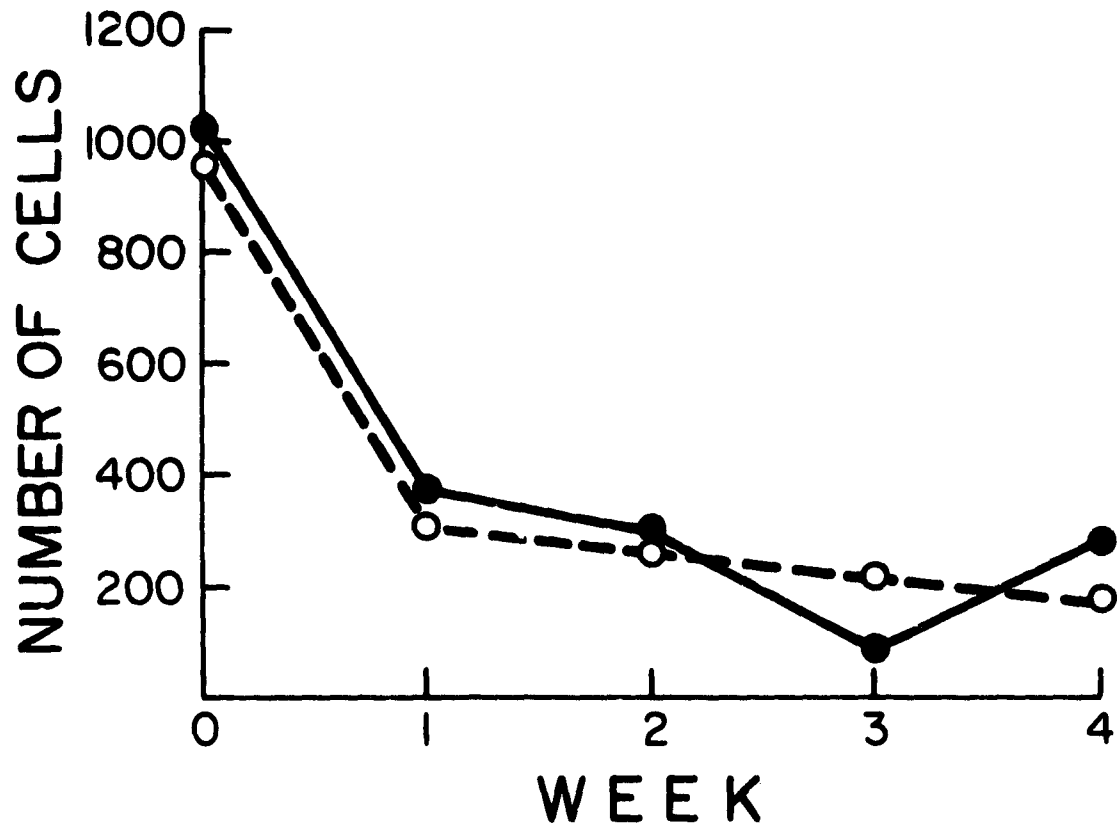

Figure 5.9 Number of cells containing honey or nectar in micro-wave (●) and sham (○) chamber colonies during chronic exposure

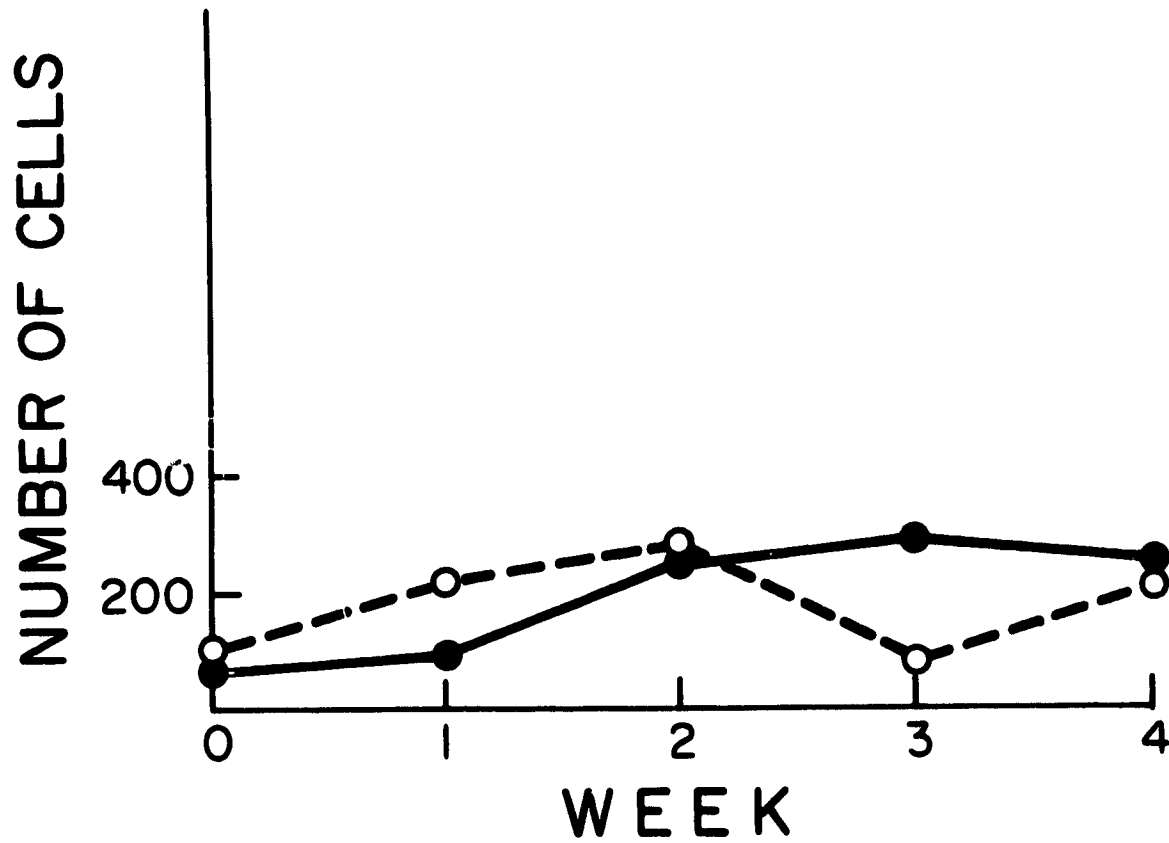

Figure 5.10 Number of cells containing pollen in microwave (●) and sham (○) chamber colonies during chronic exposure

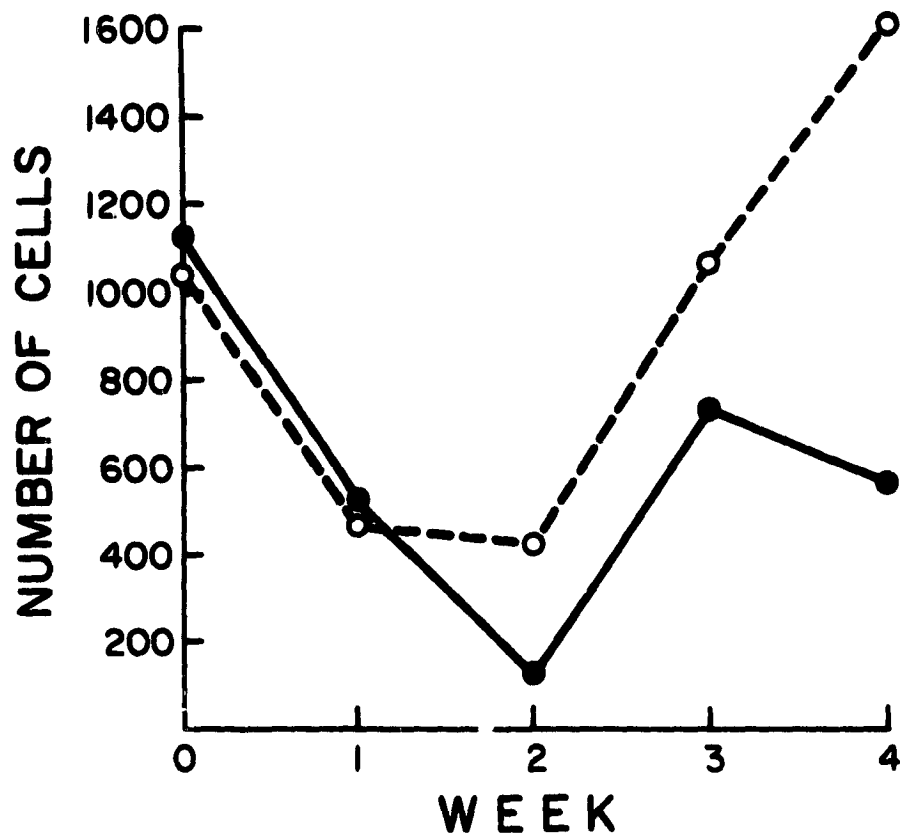

Figure 5.11 Number of empty cells in microwave (●) and sham (○) chamber colonies during chronic exposure

The weights of the microwave and sham colonies followed similar trends for 3 of the 4 weeks of the study (Fig. 12). Weights of the two colonies never exceeded a 5% difference. Of the 114 gram difference at the conclusion, 37 grams can be accounted for by a greater population of adults in the microwave-treated colony (2,609) compared to the sham colony (2,393). Otherwise, differential brood quantities accounted for the remaining weight difference. Both colonies had slightly greater adult populations at the end of the study.

This study suggests that honey bees function normally at power densities expected near the edge of the SPS rectennae. Our data support the hypothesis that invertebrates similar in size to the honey bee probably will not be affected by SPS frequency microwaves. It is also interesting to note that other forms of electromagnetic energy, viz. high voltage transmission lines presently in our environment have been shown to affect honey bee hives under certain conditions (7-8).

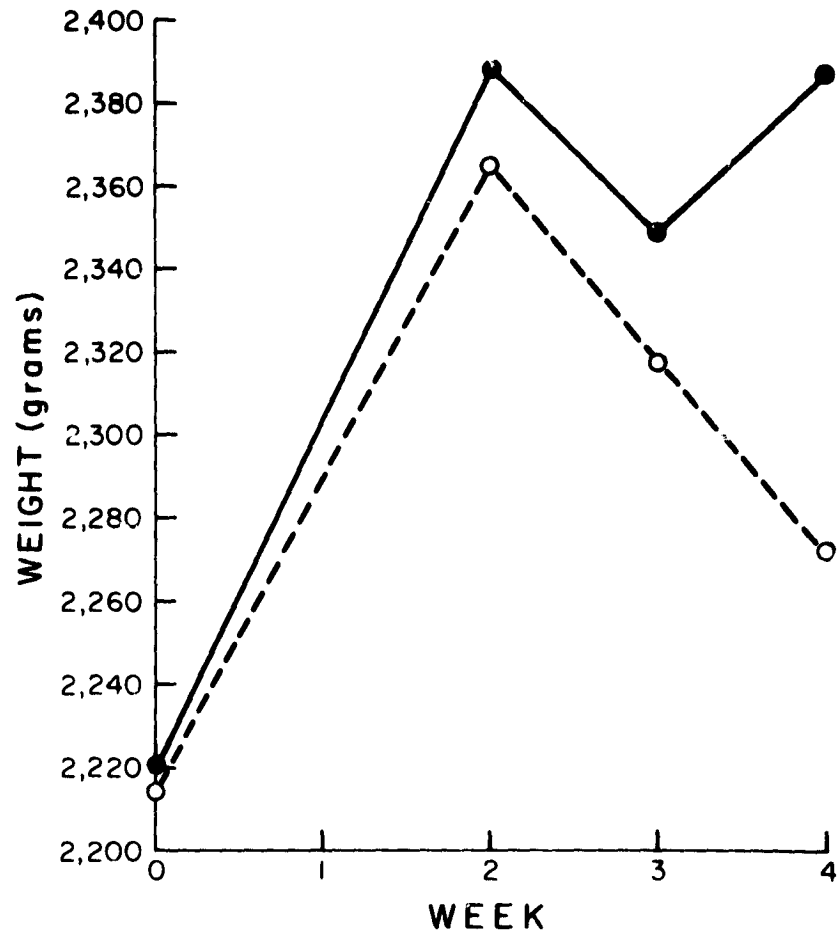

Figure 5.12 Weight of microwave (●) and sham (○) chamber colonies during chronic exposure. Weight changes are affected primarily by the amount of brood, stored honey, and adult bees, collectively

ACKNOWLEDGEMENTS

This research was supported by the Department of Energy (Satellite Power System Project Office and Office of Health and Environmental Research) through Argonne National Laboratory (contract numbers 31-109-38-4442 and 31-109-38-5066) and NASA (contract number NAS2-9539).

The authors thank S. Cobey, P. Harizanis, K. Lorenzen, S. Molnar, and T. Webster for assisting with this research. J. Ali (EPA- Research Triangle Park) and J. McGrath provided engineering services.

REFERENCES

1. P. E. Glaser, The earth benefits of solar power satellites, *Spa. Sol. Pwr. Rev.* 1, 9-38 (1980).
2. R. A. Herendeen, T. Kary and J. Rebitzer, Energy analysis of the solar power satellite, *Science* 205, 451-454 (1979).
3. F. A. Koomanoff and C. A. Sandahl, Status of the satellite power system concept development and evaluation program, *Spa. Sol. Pwr. Rev.*, 1, 67-77 (1980).
4. B. D. Newsom, Research plan for study of biological and ecological effects of the solar power satellite transmission system, NASA Contractor Report 3044, pp. 144-202 (1978), Available from National Technical Information Service, Springfield, Virginia 22161.
5. D. A. Christensen, A new non-perturbing temperature probe using semiconductor band edge shift, *J. of Bioeng.*, 1, 541-545 (1977).
6. R. Paul and U. Warnke, Das verhalten von bienenvolkern unter hochspannungsleitungen, *Biene.*, 111, 68-69, (1975).
7. G. Wellenstein, Der einflub von hochspannungsleitungen auf fienen volker. *Z. agnew. Entomol.*, 74, 86-94 (1973).
8. B. Greenberg, J. C. Kunich, and V. P. Bindokas, The effects of high voltage transmission lines on honey bees, Interim Report, EPRI EA-0841, (1978), Available from Electric Power Research Institute, Research Reports Center, P.O. Box 50490, Palo Alto, California 94303.

6 Longevity and Food Consumption of Microwave-Treated
(2.45 GHz CW) Honey Bees in the Laboratory

By

Becky Brown Westerdahl and Norman E. Gary
Department of Entomology
University of California
Davis, CA 95616

ABSTRACT

Adult honey bees, confined singly or in small clusters, were exposed for 0.5, 6, and 24 hours to 2.45 GHz continuous wave microwave radiation at power densities of 3, 6, 12, 25, and 50 mw/cm². Following exposure, bees were held in the incubator for 21 days to determine the consumption of sucrose syrup and to observe mortality.

No significant differences were found between microwave- and sham-treated or control bees.

INTRODUCTION

A new alternative energy system for obtaining solar energy from space has been proposed [Glaser, 1968, 1980]. Large Solar Power Satellites (SPS) would be placed into geosynchronous orbit where they would collect vast quantities of solar energy that would be transformed to microwaves that could be beamed to receiving antennae (rectennae) on earth. Electricity would be produced at the rectennae and transmitted by conventional high voltage lines to population centers. The system has the potential of generating up to 5 gigawatts continuously for each satellite.

One very attractive feature is the expectation of minimal ecological impact on earth. However, the complexities of biological systems demand that a thorough environmental assessment of the system be conducted prior to making major engineering commitments to such a system [Koomanoff and Sandahl, 1980]. The most obvious potential impact concerns the fate of airborne biota that either drift passively or fly actively within or near the rectennae where 2.45 GHz continuous wave microwaves may range between ca 1 mw/cm² near the edge to 23 mw/cm² at the center of the ca 10 km diameter rectennae. Furthermore, some scattering of the microwave energy would occur for great distances from the rectennae, at much lower power densities. Nevertheless, the thresholds of perception for invertebrates are unknown, and even if perceived, the behavioral and physiological responses are also unknown.

Honey bees have been chosen initially as a primary test organism for many reasons [Gary and Westerdahl, 1978], the primary ones concerning their great sensitivity to several kinds of electromagnetic radiation and their great ecological significance as pollinators in

the production of food in the United States. Consequently, this study is one of a series designed to detect any biological effects on honey bees by SPS microwaves at power densities anticipated in the SPS system. The specific objective of the research herein is to determine if prolonged microwave exposure of honey bees induces any changes in metabolism or behavior that might affect survival or longevity of confined bees.

METHODS AND MATERIALS

Experimental Design

In this factorial study, bees were exposed to 6 microwave power densities (0, 3, 6, 12, 25 and 50 mw/cm^2) for 3 exposure times (0.5, 6, and 24 hours). For each power density exposure we used 100 bees that were confined in a cylindrical cage of dimensions that required the bees to form a cluster, and 100 bees that were confined singly in compartments of small cages. In addition, two identical groups of 200 bees were used in the sham chamber and in the laboratory, respectively, as controls during the microwave exposure treatments.

The experiment was conducted in a split-plot design with the 6 exposure levels randomized as main plots and the 3 exposure durations randomly assigned to subplots within each main plot. One exposure level-duration combination (including the 2 control groups in addition to the microwave treatment group and the 2 caging regimes), consisting of 600 bees, was run on each of 18 days, yielding a total of 10,800 bees used in this study.

Exposure System

The exposure system has been described in detail elsewhere

[Westerdahl et al.]. The system was designed to simulate microwave exposure that would be encountered by airborne biota within and surrounding SPS rectennae. Honey bees in styrofoam cages were arrayed on top of a styrofoam exposure platform (61 X 61 cm) located 121 cm below a Narda standard gain horn (Model 644) mounted vertically in the top of a microwave anechoic chamber (88 X 88 X 196 cm). The anechoic chamber outer wall was constructed of plywood and lined interiorly with sheet aluminum. A second interior chamber, separated from the outer wall by a 5 cm vented air space, was constructed of microwave absorbing material (Emerson and Cuming HT-99 ceramic absorber for the walls and ceiling and SPY-12 pyramidal rubberized absorber for the floor immediately beneath the styrofoam exposure platform).

Power was conveyed from a 2.45 GHz continuous wave power supply (ripple < 1%) through waveguides into the horn. Continuous monitoring of power levels within the microwave exposure chamber was provided by a Boonton power detector (Model 41-4A) connected to a 50 dB cross guide coupler (Arra Model 284-602-50-n) and to a Data Precision digital multimeter (Model 1350). The power detector was calibrated with a Narda microwave meter (Model 8611) and probe (Model 8623) which had been calibrated against a three element orthogonal dipole probe (custom-built by Environmental Protection Agency, Research Triangle Park) that was in turn calibrated against a reference probe at the U.S. National Bureau of Standards.

The sham chamber was constructed identically to the treatment chamber and connected to it (through an insulated metal duct) as a means of receiving a constant flow of effluent air in order that bees in the sham chamber would be exposed to any chamber odors or

pheromones that may be released by the treated bees. This arrangement also equalized ambient air humidity and temperatures in both chambers during the respective treatments.

During exposure, temperatures within the chambers were monitored as follows. Gallium-arsenide fiberoptic probes (designed and constructed by D. Christensen, University of Utah) originating from a 4-probe unit were used to measure (1) ambient temperature within the microwave treatment chamber, (2) temperature within a cluster of bees in a cylindrical cage, (3) the internal thoracic temperature of an individual bee constrained by nylon strands to a styrofoam block, and (4) ambient air temperature within the sham treatment chamber. Recordings from these probes were made continuously on Omniscrite chart recorders (Model B5237-5). Additionally, two copper-constantan thermocouples (Omega Models SCPSS-020-6 and HYP-1) in the sham chamber monitored (1) temperatures within a cluster of bees in a cylindrical cage and (2) the internal thoracic temperature of an individual bee, constrained as in the treatment chamber. The thermocouples were connected to electronic ice-point references (Omega Model MCJ-T) and recordings were made on an Omniscrite chart recorder (Model B5237-5). Humidity within the sham chamber was recorded with a hygrothermograph (Bendix Model 594).

Preparation of Materials

Each morning approximately 2000 bees were removed from the same brood comb frame from each of three colonies, placed in a common cage where they were fed 50% sucrose solution, then released in a small darkened room on a platform abutting a vertical glass window with

natural backlighting, the sole source of illumination. Bees were highly attracted to the glass surface where they were captured individually and placed into one of two types of exposure cages (Fig. 1). The cylindrical cage was designed to hold 100 bees in a cluster of a size that theoretically should maximize microwave energy absorption for the wavelength (12.5 cm) that was used. This cage consisted of fiberglass window screen (10 cm long) wrapped around two styrofoam disks (4 cm in diameter and 1.5 cm thick) and secured with rubber bands, thus containing the bees in a cluster ca 5 cm long and 4 cm in diameter. During confinement bees were supplied with food, a disk of invert sugar fondant (1 cm diameter and 0.5 cm thick) on each end, adjacent to the styrofoam disks.

The second exposure cage was a rectangular styrofoam block (13 X 2.5 X 1 cm) which held 5 bees individually in circular holes (2 cm diameter and 0.7 cm deep) (Figure 1). The holes were covered with fiberglass screen secured with rubber bands. Invert sugar fondant was accessible to the bees through a hole (0.5 cm diameter) in the compartment floor. Each day 60 cages were prepared, randomized, and divided equally between the microwave, sham, and laboratory control treatments.

Microwave and sham groups were placed in identical anechoic chambers and the laboratory control group was held in the dark at room temperature and humidity throughout the exposure. Cylindrical cages were placed on their side in the center of each anechoic chamber exposure platform. Five compartment cages were placed side by side (1 cm between the long axes of the cages) on separate, portable styrofoam platforms (18 X 12 X 2.5 cm), two of which were placed on either

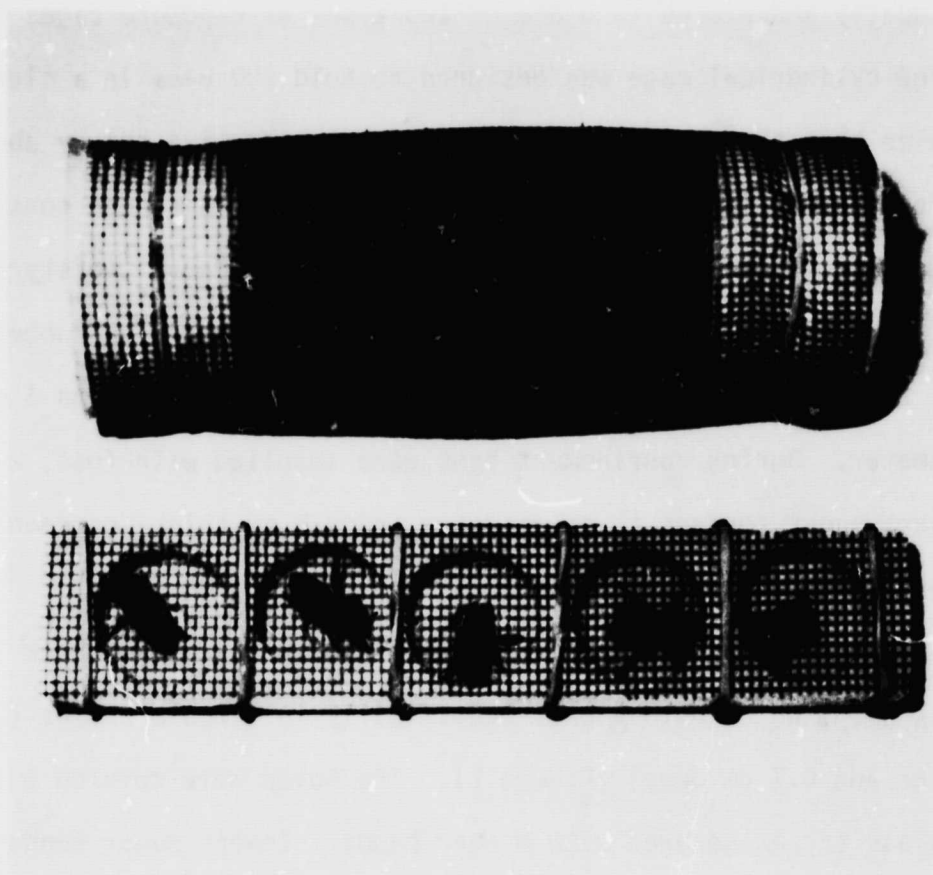

Figure 6.1 Microwave-transparent cages for confining honey bees during microwave treatments. Cages were made of styrofoam and fiberglass screen secured with rubber bands. The cylindrical cage (4 cm diameter, 10 cm long) caused clustering of bees in the reduced space. The 5-compartment cage (13 X 2.5 X 1 cm) separates bees into holes (2 cm diameter, 0.7 cm deep) for individual bee exposures

side of the cylindrical cage.

Post-exposure Procedures

Bees from each treatment group were divided into groups of 20 and transferred to cylindrical wire mesh cages (Figure 2) (15 cm long and 2 cm diameter). Ten cages were grouped together and held vertically on corks affixed to a platform (35 X 10 X 2 cm) with 5 cm between cages. A paper cylinder (21 X 4 cm) was placed around each cage to provide further separation, and especially to prevent inter-cage fecal contamination. Food (50% solution of sucrose in water) was provided in 3 ml plastic syringes (containing an opening 0.3 cm in diameter made by removing the tips), that were inserted through a piece of plastic tape that covered the top of each cage (Figure 2).

The cages were held in an incubator room (3 X 2 X 2.5 m) at $32 \pm 1^\circ \text{C}$ and 50% R. H. At three day intervals following exposure, (1) any dead bees in the cage were removed and recorded, (2) the volume of consumed sugar syrup was recorded from the calibrated syringes, and (3) new syringes with fresh syrup were provided (to reduce the possibility of fermentation). Observations were discontinued 21 days after exposure.

RESULTS AND DISCUSSION

Temperature ranges during 6 hour exposures (Table 1) were: (1) microwave chamber, ambient ($23-30^\circ \text{C}$), bee cluster ($27-36^\circ \text{C}$), single bee thoracic probe ($22-36^\circ \text{C}$) and (2) sham chamber, ambient ($24-29^\circ \text{C}$), bee cluster ($25-39^\circ \text{C}$), single bee thoracic probe ($23-35^\circ \text{C}$). Relative humidity within the sham chamber (effluent air from the microwave chamber) was 50-60%.

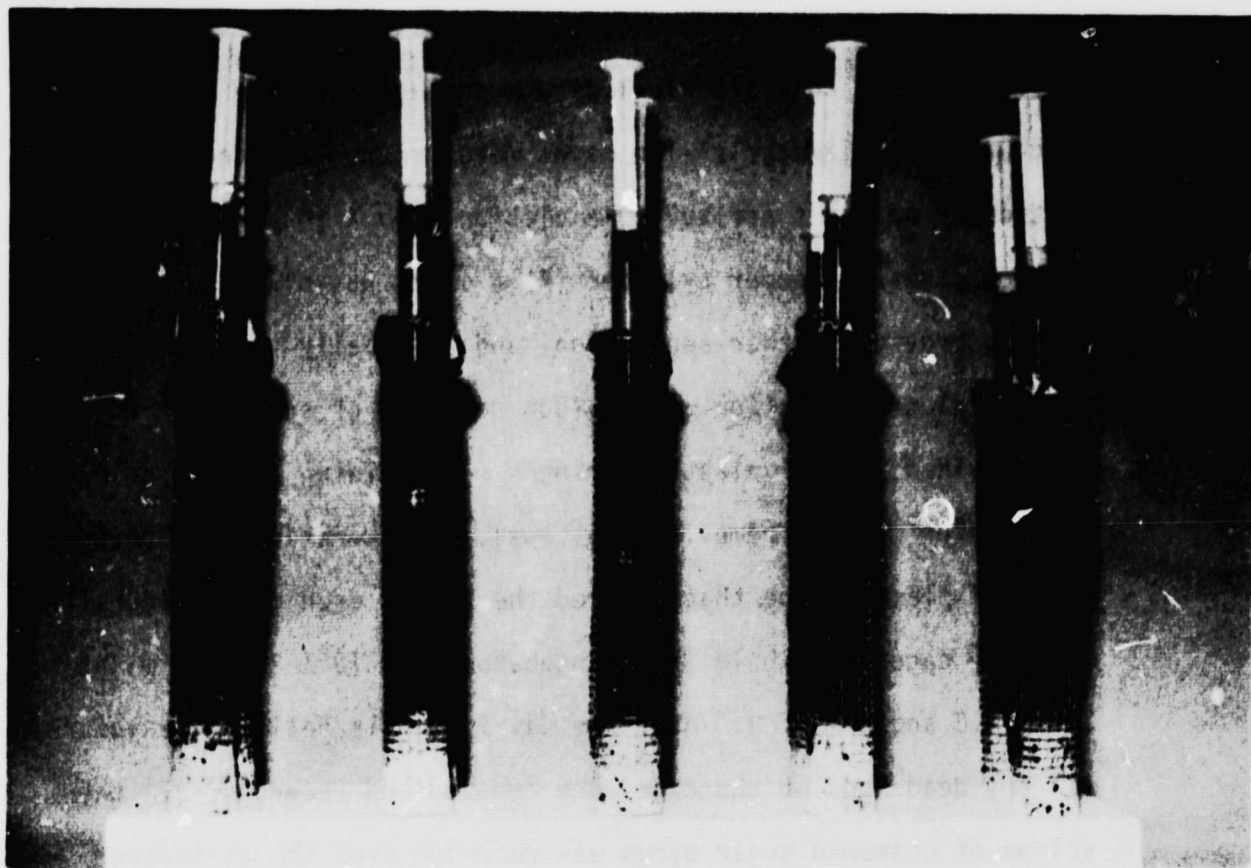

Figure 6.2 Post-treatment, 8-mesh wire cages (2 cm diameter, 15 cm long) are mounted on corks affixed to a wooden platform. Each cage holds 20 bees that have access to food (50% solution of sucrose in water) in the 3 ml plastic syringes (held in position by insertion through plastic tape) with 0.3 cm diameter openings made by removing the tips. Cages are isolated from each other by paper cylinders (21 X 4 cm) (not shown) to prevent intercage fecal contamination

Table 6.1 Temperature ranges during 6-hour exposures within sham and microwave chambers, bee clusters, and individual bee thoraxes^{a/}.

Power Density mw/cm ²	Exposure Chamber	Temperature °C					
		Ambient in Chamber		Bee Thorax (Internal)		Bee Cluster (Internal)	
		min	max	min	max	min	max
0	Sham	24	26	25	30	28	39
	Microwave	24	25	22	27	28	36
3	Sham	24	26	23	29	28	35
	Microwave	23	24	25	36	27	36
6	Sham	25	27	29	30	30	37
	Microwave	25	26	26	32	27	35
12	Sham	24	26	26	28	25	37
	Microwave	25	26	24	26	27	35
25	Sham	25	28	25	28	27	35
	Microwave	26	27	25	28	28	36
50	Sham	28	29	28	35	31	39
	Microwave	27	30	27	36	30	36

a. Mortality for the individual bees with internal thoracic probes was high for the 24-hour treatments. Consequently, all data in this table are from the 6-hour exposure treatments. Each range is based on a single sample.

There were no significant differences in rate of food consumption for any of the groups, thereby indicating that metabolic functions were normal after microwave exposure. The mean consumption per surviving bee/day was ca 30 μ l of the 50% sucrose syrup.

Daily mortality of bees for all durations of exposures was essentially identical. Consequently, only the data for 24 hr exposures are presented in Figures 3-8. There are no indications in the survival data that microwaves within the range tested have detectable effects on confined honey bees. The survival curves for all groups are extremely similar. The most probable cause of the higher survival in Figure 5 is that there may have been a significantly higher percentage of young bees in the population at the outset. This could have happened by chance if there was a brood emergence on one or two of the combs that were removed each day for sampling bees from the 3 colonies. Even so, the relative survival was the same for all treatments and controls.

Apparently the clustering of bees does not enhance the absorption of energy to the extent that any effects were noted, compared to the single bee exposures, at least with a 24 hour exposure.

CONCLUSIONS

We find no evidence that the longevity or food consumption of honey bees, held singly or in clusters, are affected by exposures (up to 24 hours) of 2.45 GHz continuous wave microwaves at selected power densities ranging from 1 to 50 mw/cm^2 , which covers and exceeds the range that is anticipated for use in the SPS system.

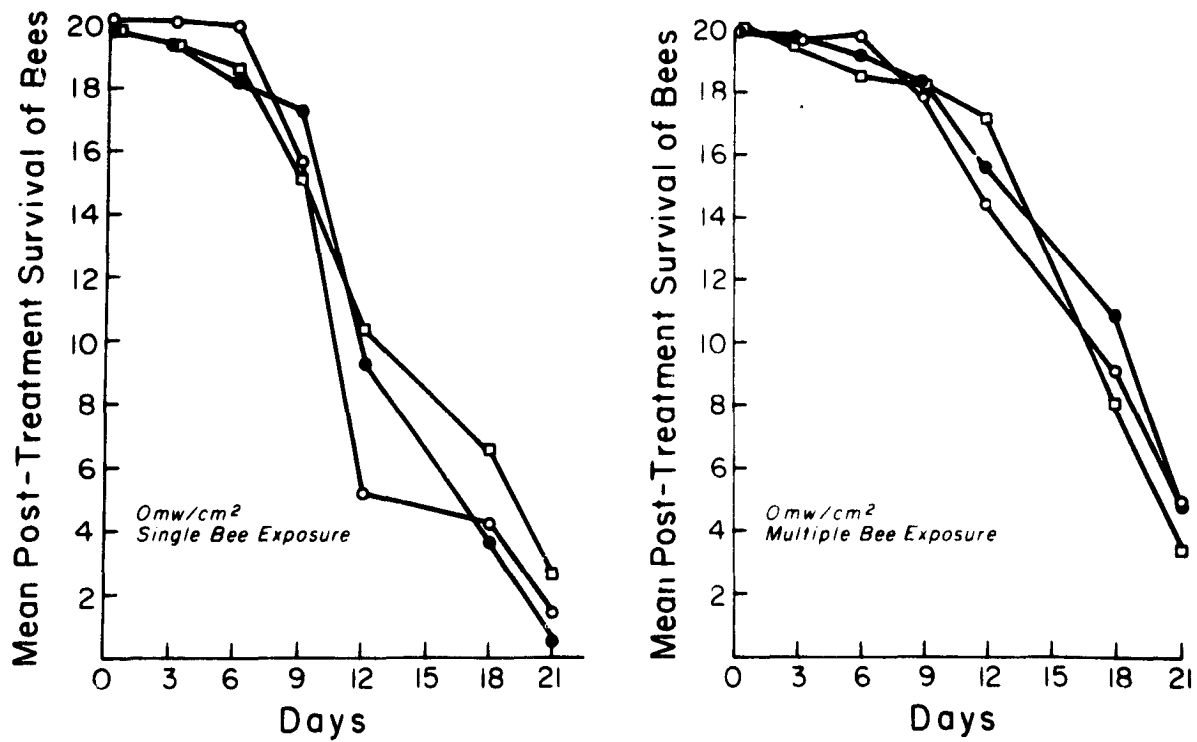

Figure 6.3 Post-treatment survival of honey bees exposed 24 hours in microwave chamber (●), sham chamber (○), and laboratory (□). Each point represents the mean of 5 cages of 20 bees each

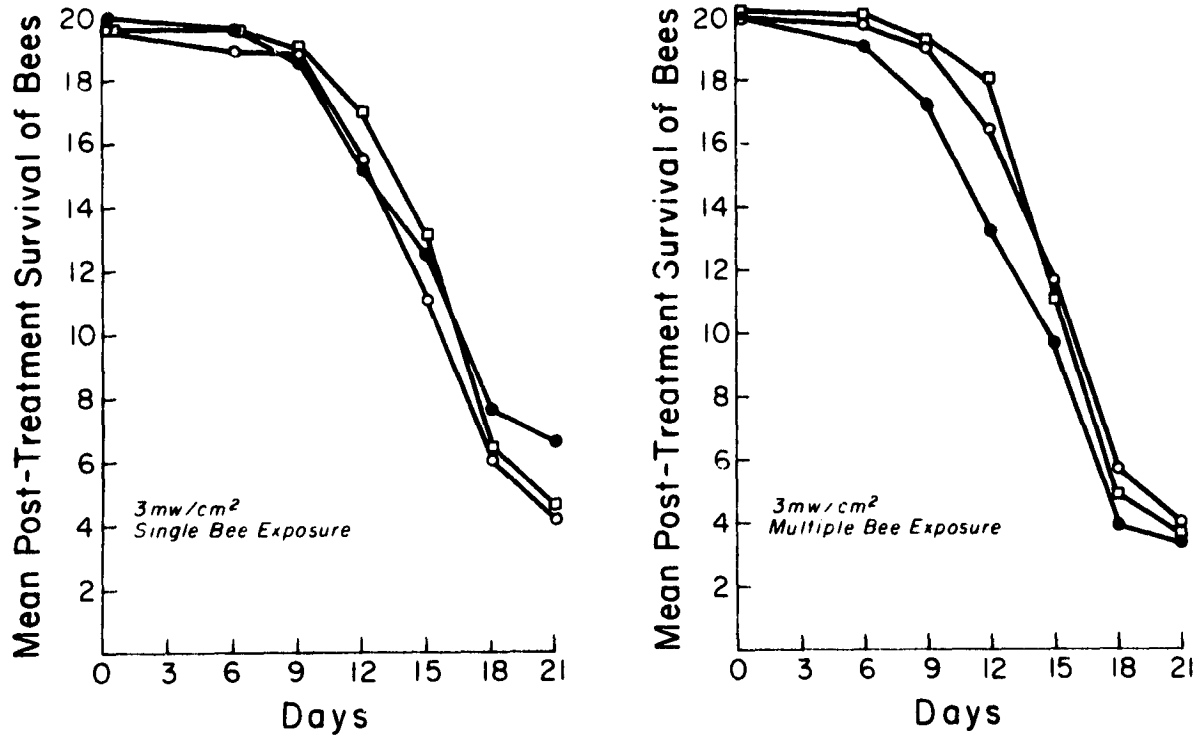

Figure 6.4 Post-treatment survival of honey bees exposed 24 hours in microwave chamber (●), sham chamber (○), and laboratory (□). Each point represents the mean of 5 cages of 20 bees each

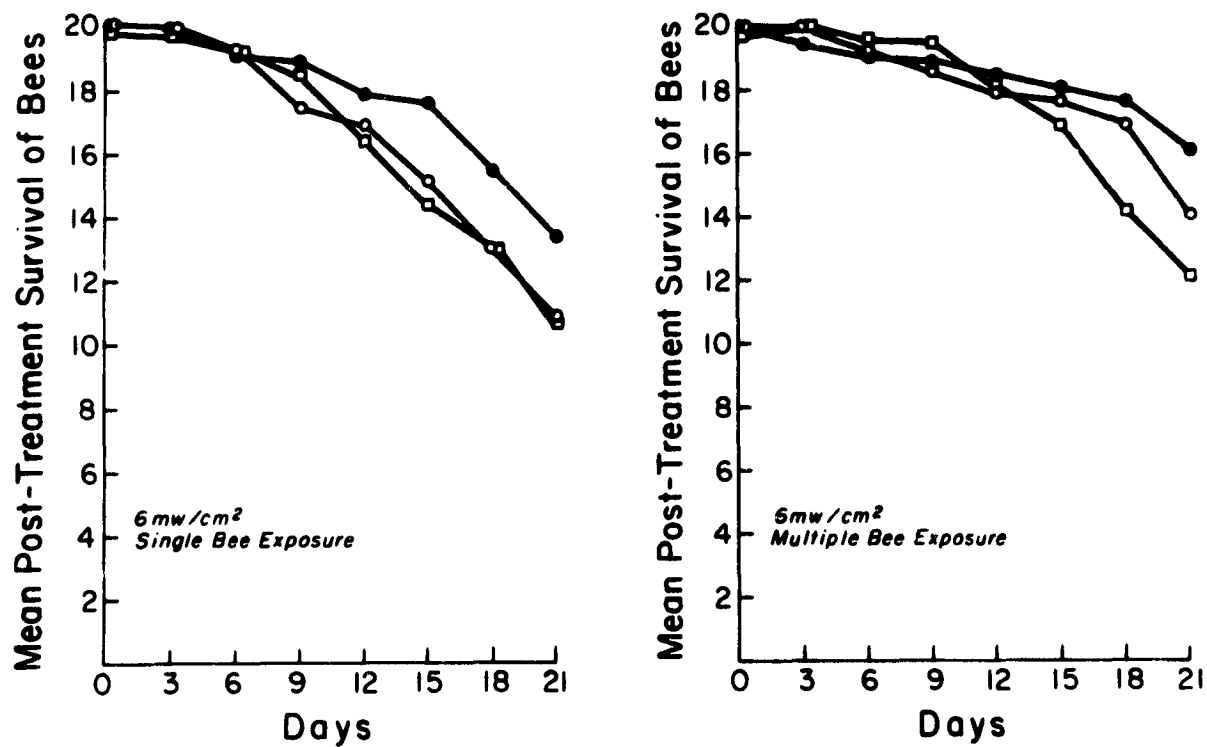

Figure 6.5 Post-treatment survival of honey bees exposed 24 hours in microwave chamber (●), sham chamber (○), and laboratory (□). Each point represents the mean of 5 cages of 20 bees each

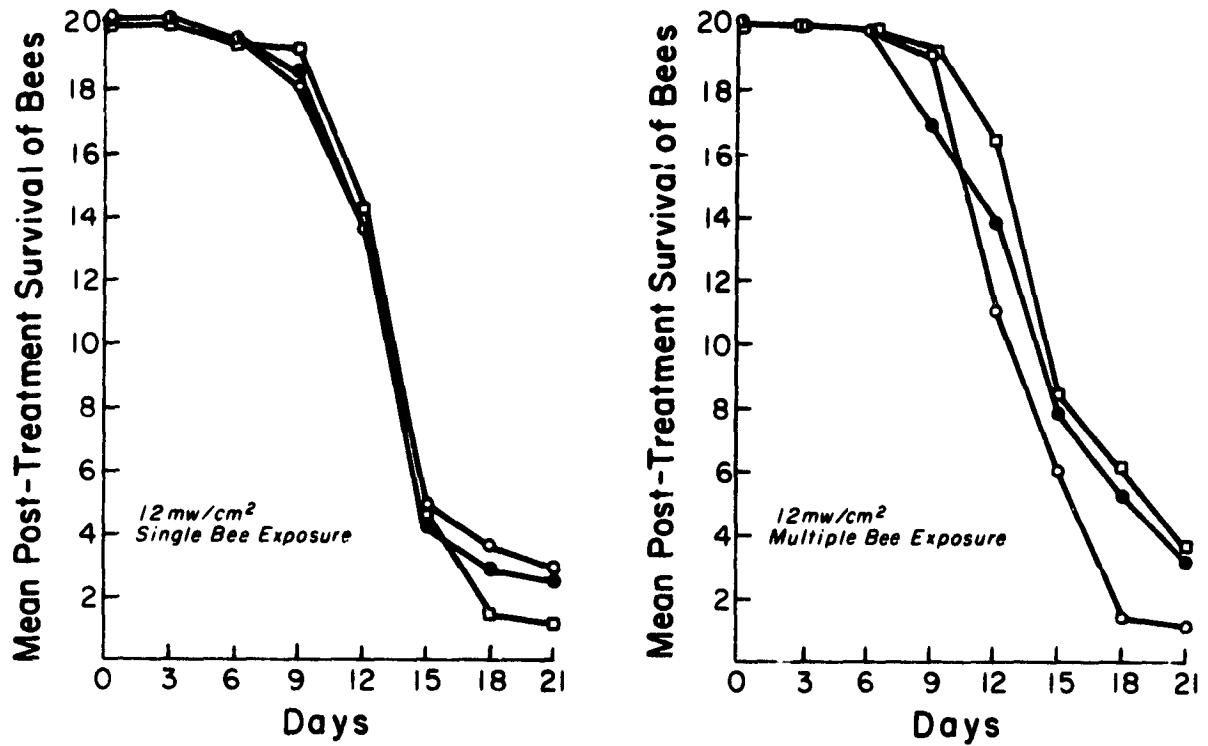

Figure 6.6 Post-treatment survival of honey bees exposed 24 hours in microwave chamber (●), sham chamber (○), and laboratory (□). Each point represents the mean of 5 cages of 20 bees each

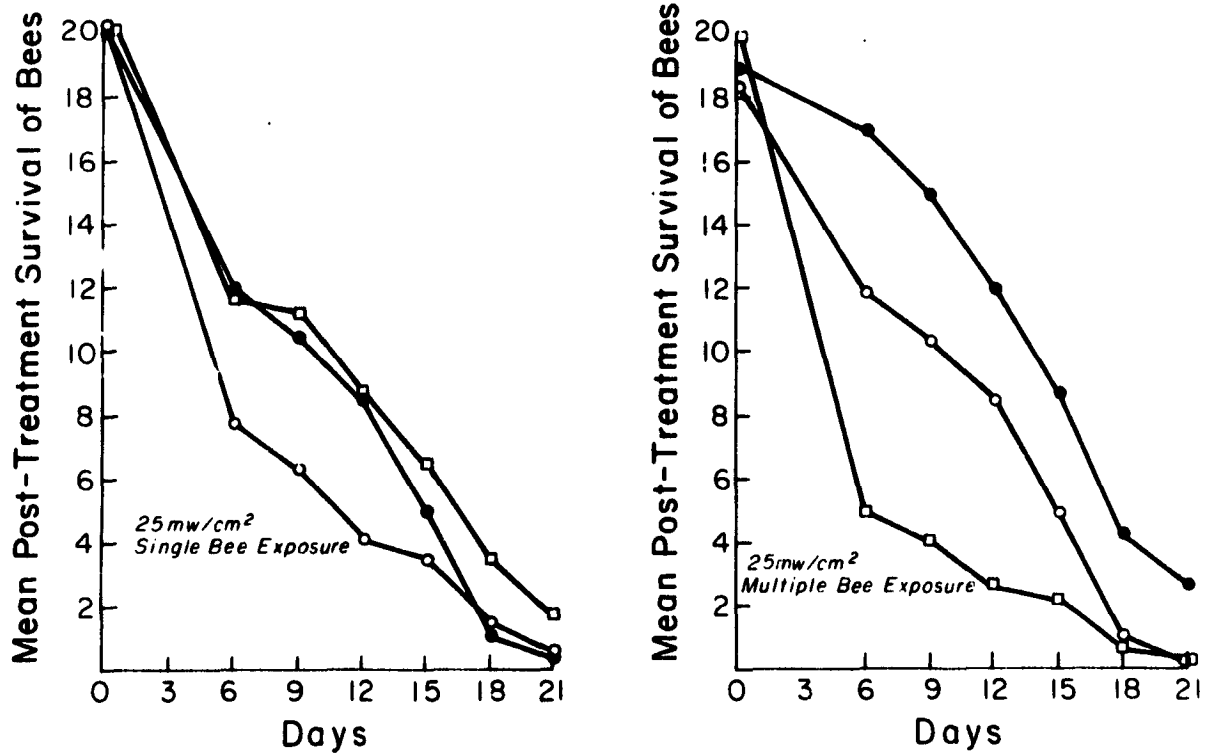

Figure 6.7 Post-treatment survival of honey bees exposed 24 hours in microwave chamber (●), sham chamber (●), and laboratory (□). Each point represents the mean of 5 cages of 20 bees each

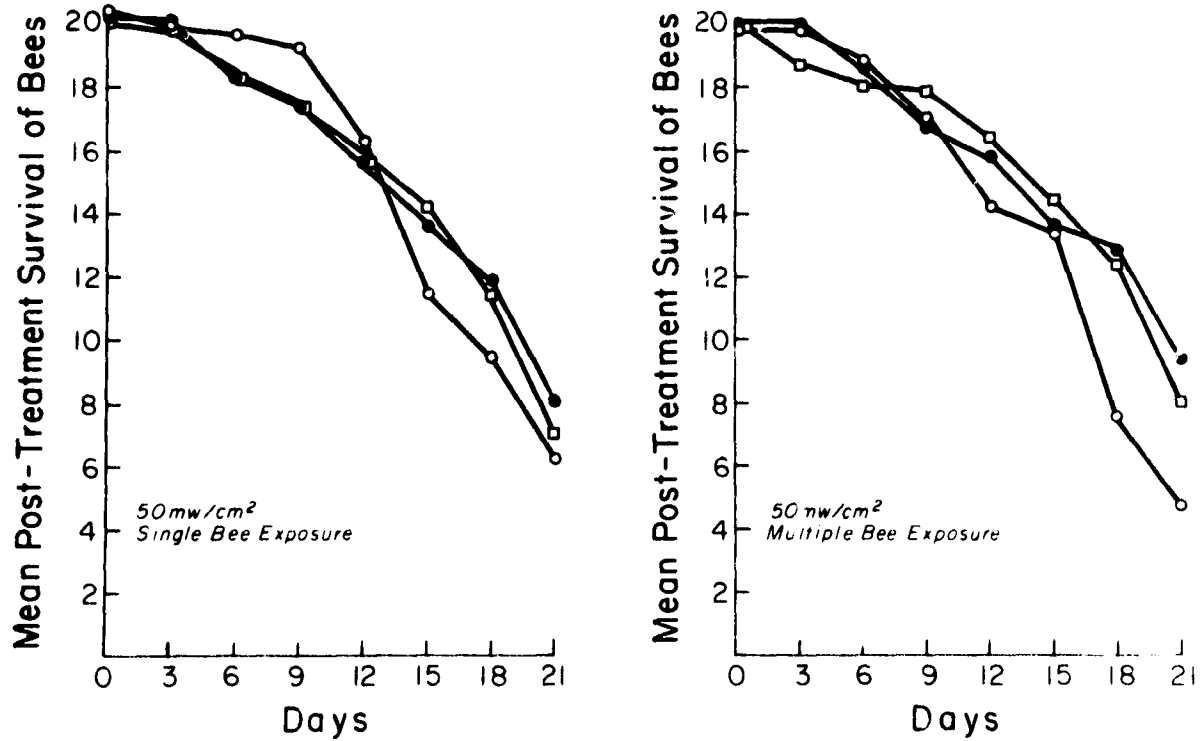

Figure 6.8 Post-treatment survival of honey bees exposed 24 hours in microwave chamber (●), sham chamber (○), and laboratory (□). Each point represents the mean of 5 cages of 20 bees each

ACKNOWLEDGEMENTS

This research was supported by the Department of Energy (Satellite Power System Project Office and Office of Health and Environmental Research) through Argonne National Laboratory (contract numbers 31-109-38-4442 and 31-109-38-5066), and by the National Aeronautics and Space Administration (contract number NAS2-9539).

We thank J. Ali (EPA-Research Triangle Park) and J. McGrath (U.C. Davis) for engineering consultation; Shu Geng (U.C. Davis) for statistical consultation; M. Andre, S. Cobey, K. Lorenzen, S. Molnar and T. Webster (U.C. Davis) for assisting with the research.

REFERENCES

- Gary NE, Westerdahl BB (1978): Study of the biological and ecological effects of energy transmission by microwaves on behavior of insects and other terrestrial invertebrates. In Newsom BD: Research plan for study of biological and ecological effects of the solar power satellite transmission system. NASA Contractor Report 3044, pp. 144-202. Available from National Technical Information Service, Springfield, Virginia 22161.
- Glaser PE (1968): Power from the sun: It's future. Science 162:857-886.
- Glaser PE (1980): The earth benefits from solar power satellites. Space Solar Power Review 1:9-38.
- Koomanoff FA, Sandahl CA (1980): Status of the satellite power system concept development and evaluation program. Space Solar Power Review 1:67-77.
- Westerdahl BB, Gary NE, Ali J, McGrath J, (1981): A system for microwave exposure of small animals. Submitted to Bioelectromagnetics.

7 Dynamics of Food Foraging of Honey Bees
In a Microwave Field (2.45 GHz CW)

by

Norman E. Gary and Becky Brown Westerdahl

Department of Entomology
University of California
Davis, CA 95616

ABSTRACT

Honey bees were trained to fly 400m from their colony to an indoor laboratory foraging arena exposed to 2.45 GHz continuous wave microwaves at 5 power densities (0, 5, 10, 20, and 40 mW/cm^2). Foraging behavior did not differ from controls foraging within an unexposed sham arena in (1) number of round trips completed during a three hour exposure session, (2) in round trip time between the colony and the foraging arena or (3) in the length of time required to navigate the illuminated foraging arena. This study indicates that honey bees would not be adversely affected by foraging within a similar microwave field that would exist in future receiving antennae for the proposed Solar Power Satellite energy transmission system in which power levels are expected to range from 23 mW/cm^2 at the antenna center to 1 mW/cm^2 at the edge.

INTRODUCTION

Limited nonrenewable energy sources and the concern for harmful environmental effects resulting from the use of such fuels has stimulated research on technologies which would utilize the sun as an inexhaustible source of energy. One of the more promising solar energy proposals from economic (Herendeen et al. 1979), engineering (Kraft and Piland 1980), and pollution (Glaser 1980) standpoints is that of placing up to 60 satellites into geosynchronous orbit above the United States to collect solar energy and transport this energy via microwave beams (2.45 GHz continuous wave) to receiving antennae on earth for conversion into electricity. Each solar power satellite (SPS) would be capable of producing 5 gigawatts of electricity, equivalent to the yield of several conventional coal or nuclear power plants. The Department of Energy and the National Aeronautics and Space Administration have conducted a feasibility study to determine if there may be any unacceptable environmental problems associated with this new technology (Koomanoff and Sandahl 1980). One major concern is the exposure of airborne biota within and near microwave-receiving antennae (rectennae) that will be ca 10 Km in diameter. Maximum power densities of 23 mw/cm² are expected at the center of rectennae and should diminish to 1 mw/cm² at the outer edge. Extremely low levels would be experienced at considerable distances outside the rectennae.

Engineering models predict that invertebrates would not be affected adversely by microwaves to be used in the SPS system. Terrestrial invertebrates are usually much smaller than the SPS wavelength (12.5 cm) and thereby should experience minimal energy

absorption, rendering them essentially "invisible" to SPS microwaves. However, virtually nothing is known about the potential of invertebrates for perceiving this form of energy or, if perceived, the amount that would constitute a "meaningful" stimulus to which adaptive behavioral reactions may occur. Furthermore, there appears to be a great concern by the general public regarding any potential responses, behavioral or otherwise, of animals, especially those that appear vital to the preservation of the existing environment.

In order to answer some of the questions concerning possible effects of SPS microwaves on invertebrates, we proposed a comprehensive series of experiments that are described in detail in a previous report (Newsom 1978). The honey bee (Apis mellifera L.) was chosen for initial studies for a number of reasons including: (1) it is a flying invertebrate that cannot be excluded from rectennae, (2) it has a short life cycle and can be reared economically in large quantities so that many generations and large numbers of individuals can be studied rapidly, (3) it has a large number of highly stereotyped behavioral patterns that can be quantified accurately, (4) previous studies have shown that bees are sensitive to various forms of electromagnetic radiation, (e.g., Greenberg et al. 1978, Paul and Warnke 1975), and (5) it is economically important by virtue of pollinating flora in undisturbed areas and crops that account for ca one-third of the food produced in the United States (McGregor 1976).

The objective of this study is to determine if foraging behavior is altered by exposure of honey bees to SPS microwaves. Behavioral bioassays are an efficient means of detecting significant changes in

physiology or biochemistry inasmuch as normal behavior is an expression of the normal physiological and biochemical mechanisms, collectively. Significant changes in behavior presumably could constitute a threat to survival. Specifically, this study was designed to provide a laboratory simulation of microwave exposure within or near the rectenal area where airborne invertebrates, especially honey bees, may enter while foraging or simply flying through the area. Will honey bees enter a microwave field of intensity equal to or higher than expected in the rectennal area and would they continue to forage during exposure?

METHODS AND MATERIALS

A population of bees was trained (Gary and Witherell 1970) to fly from an isolated colony located 400 m northeast of the laboratory to identical treatment and sham microwave anechoic chambers with entrances located 4 m north and west, respectively, from the southeast corner of the laboratory. We used a genetically-marked colony, homozygous (cd/cd x cd) for cordovan (Levin 1959), because the bees were easily identifiable visually by their cordovan-colored body, compared to common bee stock that is darker in color. Easy identification was essential to insure that bees from other non-cordovan colonies in the area would not be included accidentally in the experiment. The trained cordovan bees were attracted to sugar syrup (25% sucrose without scent) feeder dishes (that simulated a rich nectar source) placed at the entrances of both the sham and treatment chambers (Fig. 1).

The dishes were moved gradually farther inside the runways, enclosed by removable glass plates, until the bees learned to enter

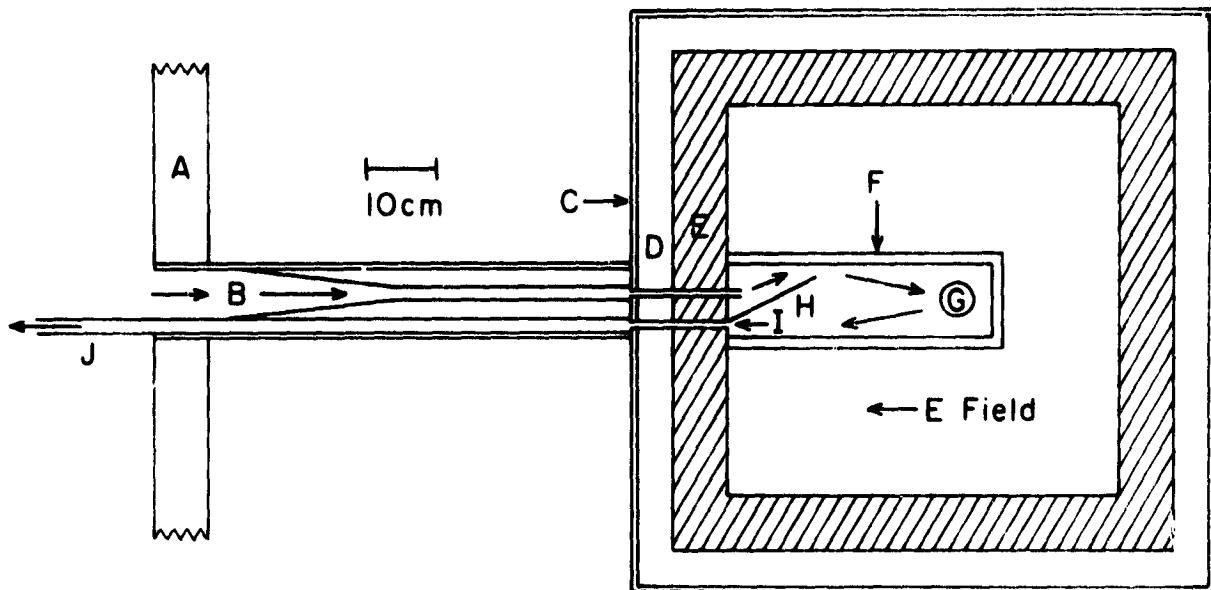

Figure 7.1 Cross section (horizontal) of anechoic chamber showing the foraging arena with entrance and exit tubes that allow bees to enter and leave the chamber during microwave exposure. (A) laboratory wall, (B) runway entrance with constricting walls that guide bees to the entrance tube, (C) exterior wall (plywood and aluminum) of chamber, (D) 5 cm vented air space, (E) internal chamber wall constructed of microwave-absorbing material, (F) styrofoam foraging arena covered with fiberglass screen, (G) artificial flower (feeder) containing sucrose syrup, (H) area constricted by angular cardboard partition to guide exiting bees to exit tubes, (I) exit tube, (J) extension of exit tube beyond laboratory wall to inhibit the entry of bees

area B inside the laboratory. Any non-cordovan bees that appeared were immediately captured and sacrificed, a practice that was continued throughout the experiment. Populations increased rapidly, owing to the efficient communication system of honey bees (Frisch 1967). When ca 50 bees were actively foraging at each of the respective runways, the runway feeding dishes were removed. Intensive searching behavior ensued; within minutes a few bees learned to enter the chambers via the plexiglas tube (1.9 cm I.D., 2.5 cm O.D., and 33 cm long) which reduced to a smaller tube (0.95 I.D., 1.3 cm O.D., and 15 cm long) to the chamber runway (F) where they discovered the feeder (G), a polystyrene petri dish (5.5 cm dia. and 1.3 cm deep) recessed in the floor with the upper rim flush with the floor. Inside the dish was ca 15 ml of 25% sucrose syrup on top of which floated a thin (0.2 cm) styrofoam disc (4.9 cm dia.) on which bees stood while feeding around the periphery. The feeder was designed to expose the minimum syrup, consistent with easy access, in order to prevent bees from falling into the syrup where they would become fouled and unable to fly. After feeding, exiting bees tended to accumulate in area H where they were guided to the exit tube opening (I) by a cardboard partition (15 cm long). The small exit tube (13.5 cm long) connected to a larger exit tube (J) that extended 16 cm beyond the outer laboratory wall as a means of preventing arriving bees from entering the exit tube. Bees quickly learned to move through the system during the initial foraging trips. They were free at all times to exit from any area of the system by either the entrance or exit tubes. All movements of bees outside the chambers could be observed in the transparent runway system.

Two days prior to onset of the microwave treatments, 25 trained foragers were sampled randomly from each chamber by permitting them to enter a small cylindrical 8-mesh wire cage that telescoped momentarily over the end of the exit tunnel (J). Captured bees were individually narcotized by a 10 sec exposure to carbon dioxide to facilitate gluing a numbered identification tag (manufactured for bees by Chr. Graze KG, 7056 Weinstadt-Endersbach, West Germany) to the thorax. Tagged bees were released immediately at the point of initial capture for resumption of foraging. Thereafter the populations of foraging bees at each chamber were stabilized by capturing and sacrificing all untagged bees, including additional unwanted bees recruited to the chambers by the tagged bees. Tagged bees, with few exceptions, foraged exclusively at the chamber to which they were trained initially. Fidelity to small foraging areas is a typical behavior (Singh 1950) that was enhanced in this study by affixing a large (38 x 28 cm) blue or yellow card on each outside entrance, respectively, to provide orientation cues that simulated flower color. Tagged bees that "crossed over" to the wrong chamber were sacrificed.

The following procedures were repeated on each of five consecutive days. Early each morning the existing tagged bees recruited new populations to each anechoic chamber, of which ca 75 were permitted to learn, primarily by following tagged bees, to forage in the chambers. After ca an hour of foraging experience the tagged bees from the previous day were sacrificed and 25 newly recruited bees were tagged for each chamber, respectively, as described previously. Tagging operations required ca 2 hours. The newly tagged bees were

allowed to forage for ca 2 more hours to insure complete recovery from the tagging operation and to permit bees adequate time to attain stabilized foraging activities. Then a 3 hour microwave treatment was initiated each afternoon in which the power density levels in the treatment chamber were set randomly at 0, 10, 40, 20 and 5 mw/cm² on each of the five days, respectively.

Data recorded during the 3 hour treatment period were used to determine (a) the total number of round trips, (b) the mean round trip time, and (c) the mean time each bee was inside the anechoic chamber. Data were based on bees that made at least 12 trips during the 3 hours. Data at each chamber were recorded continuously by 2 observers, one inside the laboratory to record the tag number and entrance time as the bees passed a given point in the large entrance tube, and the other outside to record the tag number and exit time from exit tube (J). An audible alarm signaled at one minute intervals to coordinate data recording by the 4 observers. Microwave exposure was continuous in the treatment chamber throughout each 3 hour session, except for a 2 minute period each half hour when the power was turned off while refilling the feeders.

The microwave anechoic chamber closely simulated conditions anticipated within and surrounding the SPS rectennae. Power was conveyed from a 2.45 GHz continuous wave power supply (ripple < 2%) through waveguides into a Narda standard gain horn (model 644) that was oriented vertically within the anechoic chamber. A Boonton power detector (Model 41-4A) connected to a 50 dB cross guide coupler (Arra model 284-602-50-n) and to a Data Precision digital multimeter (model 1350) provided a continuous readout of power levels within

the microwave exposure chamber. The power detector was calibrated with a Narda microwave meter (model 8611) and probe (model 8623) that had been calibrated against a custom-built three element orthogonal dipole probe (courtesy of Environmental Protection Agency, Research Triangle Park) which was in turn calibrated against a reference probe at the U. S. National Bureau of Standards.

A cross section diagram of one of the two anechoic chambers used in this study is shown in Fig. 1. These rectangular chambers (88 X 88 X 196 cm) were constructed of plywood lined interiorly with sheet aluminum (D). A vented air space (D) separated the outer chamber from an inner chamber wall constructed of microwave absorbing material (Emerson and Cuming HT-99 ceramic absorber for the walls and ceiling and SPY-12 pyramidal rubberized absorber for the floor). The exposure area (61 X 61 cm) was located 121 cm from the horn and corresponded to the floor of the chamber foraging runway (F). The chamber was passively cooled by air vents located at the top of the air space and actively cooled by a fan (Pamotor model 7606) blowing air into the bottom of the chamber. All materials used in constructing the runway (F) within the chamber were microwave-transparent, e.g., the runway arena (38 X 12 X 2 cm) was made of styrofoam covered with fiberglass screen on top.

Temperatures were monitored continuously during exposure within the foraging arena and within the feeder solution with a gallium-arsenide fiber optic temperature monitoring unit (designed and custom-built by D. Christensen, University of Utah) and recorded on an Omniscribe chart recorder (model B5237-5). Temperatures within the sham foraging arena and feeder were monitored continuously with

copper-constantan thermocouples (Omega models SCPSS-062E-6 and SCPSS-020E-6, respectively) connected to electronic ice-point references (Omega model MCJ-T) and recorded on an Omniscribe chart recorder (model B5237-5).

RESULTS AND DISCUSSION

During the 5 day study, 181 (93 and 88 for the treatment and sham chambers, respectively) of the 250 tagged bees returned to forage after tagging, a high rate of return considering the brief training period and the probability that some bees were tagged before establishing a fixed behavior pattern at the food source. Relatively naive, newly-recruited bees have a low tolerance for disturbance, i.e., they frequently cease visitation to the area if disturbed significantly. Of the returning foragers, 13 (4 and 9 trained to the treatment and sham chambers, respectively) were excluded from data analysis because of inconsistent foraging activity, according to the criteria mentioned earlier.

The mean daily foraging populations did not differ significantly for the microwave (18 ± 4) and sham (16 ± 3) chambers (Fig. 2). During the 3-hour observation periods bees made ca 20-30 round trips (Fig. 2). There was no evidence that the microwave field deterred entry into the chamber.

The mean round trip times and time spent in the foraging arena are summarized in Figs. 3 and 4, respectively. No significant differences were found at any of the power levels. Our data indicate that microwave-treated bees experienced no detectable alterations in orientation and navigation behavior, either while flying between the field colony and laboratory or while navigating within the chamber

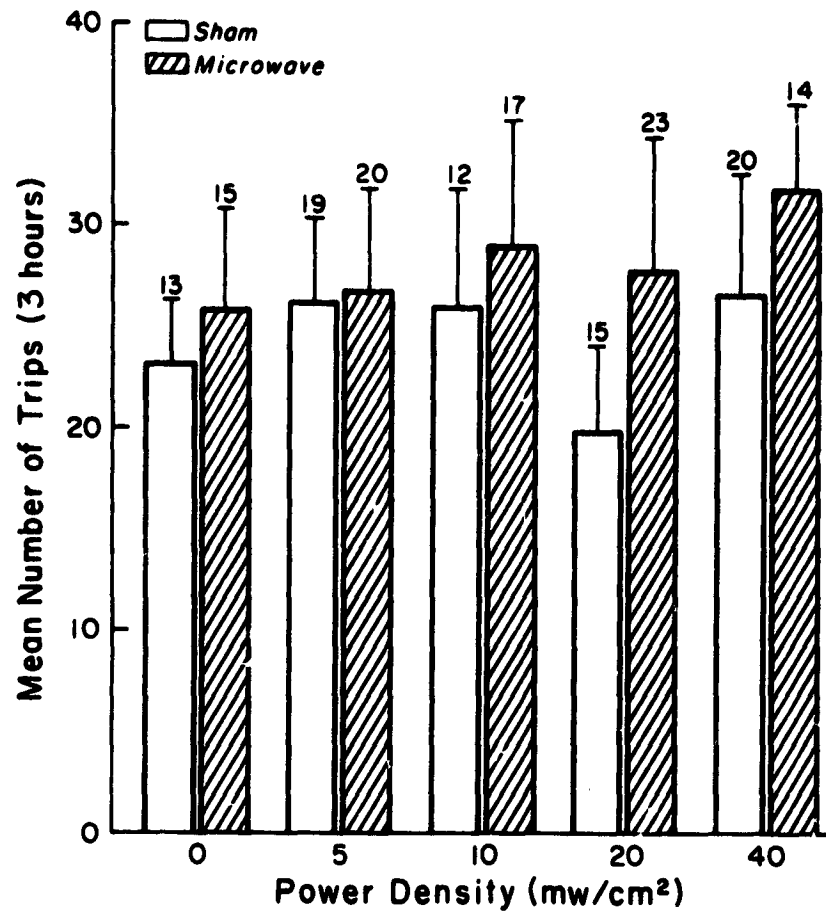

Figure 7.2 Mean number of round trips per bee from hive to the chambers, plus one standard deviation. Figure above standard deviation mark is the number of bees for each treatment that completed at least 12 round trips during the 3-hour period

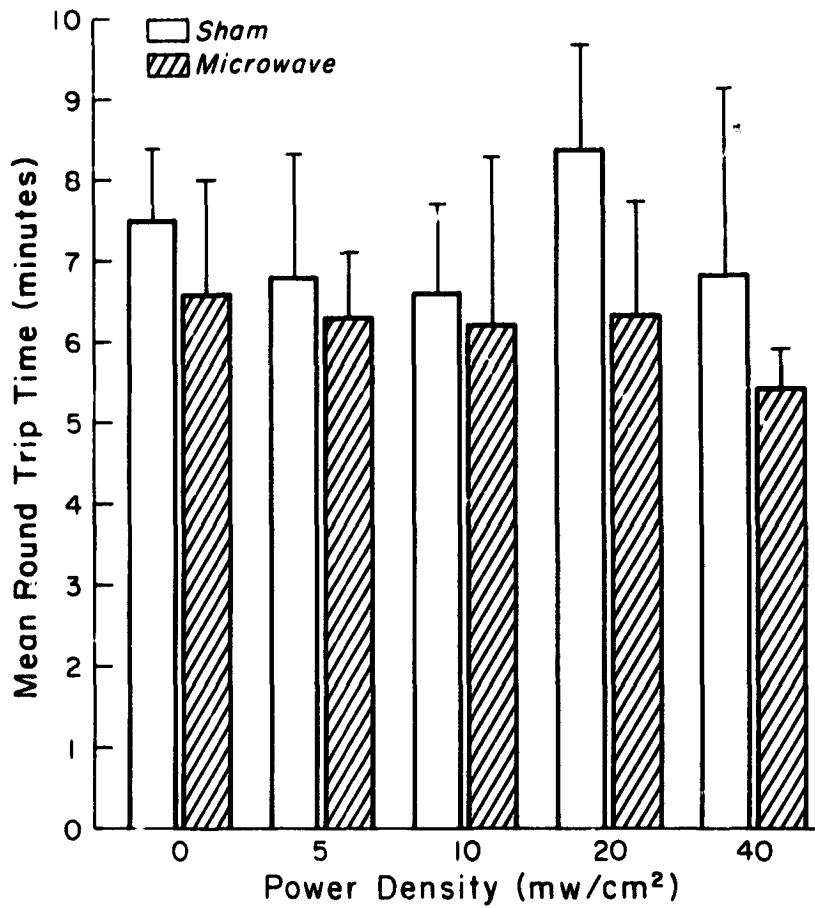

Figure 7.3 Mean round trip time per bee from the hive to the chambers at the various power densities tested, plus one standard deviation

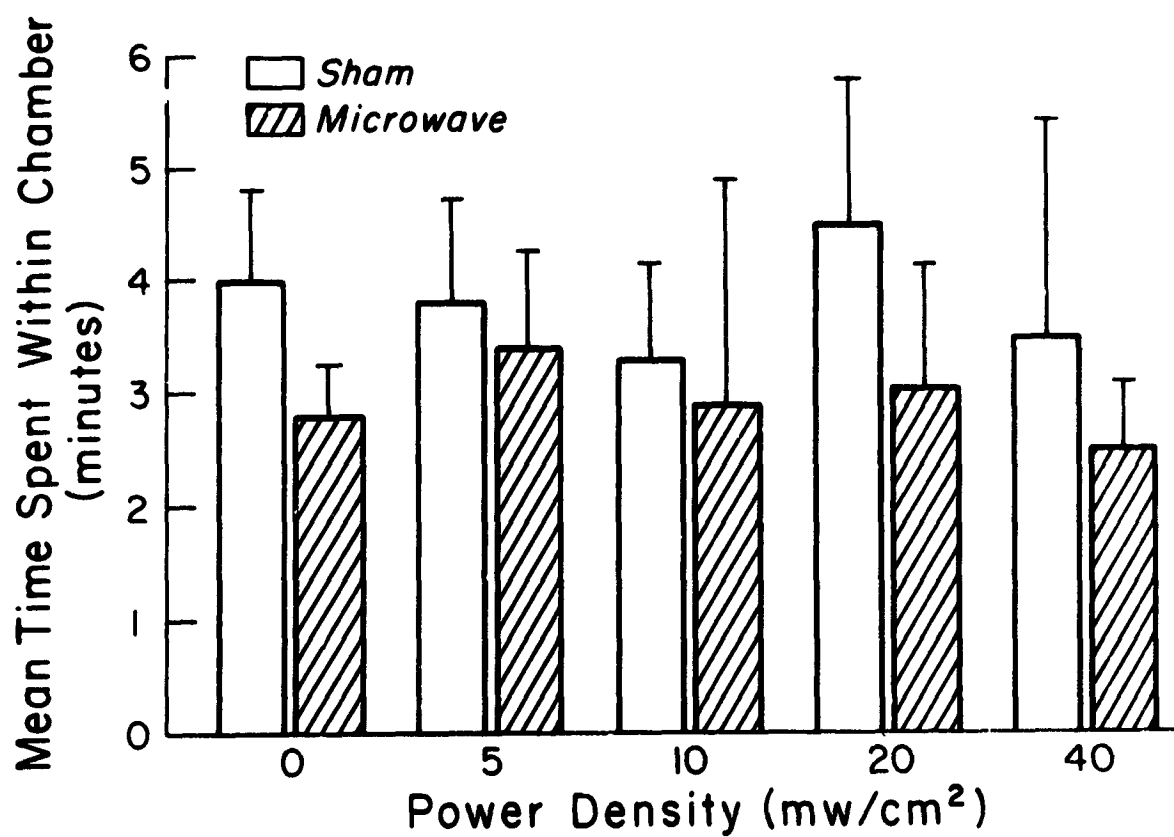

Figure 7.4 Mean time during each trip that was spent within the foraging arena at the various power densities, plus one standard deviation

system. Approximately 5.5-8.5 minutes were required by most bees to complete a round trip, including 2.5-4.0 minutes within the chambers, indicating that bees in the treated chamber were exposed to microwaves during ca half of the 3-hour treatment periods.

This study provided evidence that honey bees readily enter microwave fields at power densities similar to and exceeding those expected to be present in rectennae of the proposed SPS system. It also establishes that the honey bees perform normally during and following microwave exposure, unlike the effects of 2.45 GHz microwaves on Y-maze learning in white rats at 50 mw/cm² in which the learning curve was significantly better for the exposed than for the unexposed rats (Nealeigh et al. 1971).

Although previous studies with indoor foraging arenas (Bermant and Gary 1966, Nunez 1970) have been used, this is the first study in which such arenas have been utilized to survey possible performance decrement effects from environmental pollutants. This system has great potential for studying the effects of a great variety of treatments ranging from various frequencies of electromagnetic radiation to toxic materials in the environment.

Surprisingly few non-cordovan bees from other colonies discovered the food sources during this study, probably because there was a gentle inward flow of air at the entrances caused by a slight negative pressure of the building. The attractive odors from the bees and the food source, normally used as orientation cues by naive bees in finding a feeding station, were thus removed and exhausted at other locations which attracted newly-recruited bees away from the functional entrances. This system permits large populations of bees to be

monitored and fresh populations to be generated for each treatment as a means of preventing interactions between treatments when the same individuals are used for various treatments.

ACKNOWLEDGEMENTS

This research was supported by the Department of Energy (Satellite Power System Project Office and Office of Health and Environmental Research) through Argonne National Laboratory (contract numbers 31-109-38-4442 and 31-109-38-5066), and by the National Aeronautics and Space Administration (contract number NAS2-9539).

The authors thank M. Andre, S. Cobey, K. Lorenzen, D. Mathan, S. Molnar, S. Morrow, and T. Webster for assisting with this research. J. Ali (EPA-Research Triangle Park) and J. McGrath provided engineering services.

REFERENCES CITED

- Bermant, G. and N. E. Gary. 1966. Discrimination training and reversal in groups of honey bees. *Psychon. Sci.* 5:179-80.
- Frisch, K. von. 1967. The dance language and orientation of bees. The Belknap Press of Harvard University Press. Cambridge, Mass.
- Gary, N. E. and P. C. Witherell. 1970. A method for training honey bees to forage at feeding stations. *Ann. Entomol. Soc. Amer.* 64:448-49.
- Glaser, P. E. 1980. The earth benefits of solar power satellites. *Space Solar Power Rev.* 1:9-38.
- Greenberg, B., J. C. Kunich, and V. P. Bindokas. 1978. The effects of high voltage transmission lines on honey bees. Interim report, EPRI EA-841. Available from Electric Power Research Institute, Research Reports Center, P.O. Box 50490, Palo Alto, CA 94303.
- Herendeen, R. A., T. Kary and J. Rebitzer. 1979. Energy analysis of the solar power satellite. *Science* 205:451-54.
- Koomanoff, F. A. and C. A. Sandahl. 1980. Status of the satellite power system concept development and evaluation program. *Space Solar Power Rev.* 1:67-77.
- Kraft, C. C. Jr. and R. O. Piland. 1980. The solar power satellite concept - the past decade and the next decade. *Space Solar Power Rev.* 1:39-65.
- Levin, M. D. 1959. Distribution patterns of young and experienced honey bees foraging on alfalfa. *J. Econ. Entomol.* 52:969-71.
- McGregor, S. E. 1976. Insect pollination of cultivated crop plants. Agricultural Handbook No. 496. ARS-USDA. U.S. Government Printing Office.

- Nealeigh, R. D., R. J. Garner, R. J. Morgan, H. A. Cross, and P. D. Lambert. 1971. The effect of microwaves on Y-maze learning in the white rat. *Journal of Microwave Power*. 6:49-54.
- Newsom, B. D. 1978. Research plan for study of biological and ecological effects of the solar power satellite transmission system. NASA Contractor Report 3044, p. 144-202. Available from National Technical Information Service, Springfield, Virginia 22161.
- Nunez, J. A. 1970. The relationship between sugar flow and foraging and recruiting behaviour of honey bees (Apis mellifera L.) *Animal Behavior*. 18:527-38.
- Paul, R. and U. Warnke. 1975. Das verhalten von bienenvolkern unter hochspannungsleitungen. *Biene*. 111:68-69.
- Singh, Sardar. 1950. Behavior studies of honeybees in gathering nectar and pollen. Memoir 288. Cornell Univ. Ag. Exp. Sta.