

N O T I C E

THIS DOCUMENT HAS BEEN REPRODUCED FROM
MICROFICHE. ALTHOUGH IT IS RECOGNIZED THAT
CERTAIN PORTIONS ARE ILLEGIBLE, IT IS BEING RELEASED
IN THE INTEREST OF MAKING AVAILABLE AS MUCH
INFORMATION AS POSSIBLE

FINAL REPORT

(NASA-CR-164291) A STUDY OF POULTRY
PROCESSING PLANT NOISE CONTROL TECHNIQUES
Final Report (Georgia Inst. of Tech.) 98 p
HC A05/MF A01 CACL 20A

N81-23863

Unclas
42318

G3/71

A STUDY OF POULTRY PROCESSING PLANT NOISE CONTROL TECHNIQUES

Prepared by

J. C. Wyvill

W. G. Morrison, Jr.

Prepared for

NATIONAL AERONAUTICS AND SPACE ADMINISTRATION
LEWIS RESEARCH CENTER
CLEVELAND, OHIO

Under

Research Grant No. NSG 3228

MAY 1981

GEORGIA INSTITUTE OF TECHNOLOGY

Engineering Experiment Station

Atlanta, Georgia 30332



1981

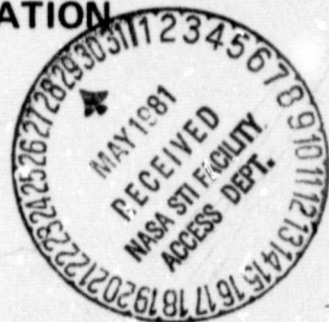

A STUDY OF POULTRY PROCESSING PLANT
NOISE CONTROL TECHNIQUES

Final Report

for

Research Grant No. NSG 3228
National Aeronautics and Space Administration
Lewis Research Center
Cleveland, Ohio

Prepared by

J. C. Wyvill
W. G. Morrison, Jr.

GEORGIA INSTITUTE OF TECHNOLOGY
Engineering Experiment Station
Atlanta, Georgia 30332

May 1981

TABLE OF CONTENTS

	<u>Page</u>
ACKNOWLEDGEMENTS.....	1
RECOMMENDATIONS.....	2
SUMMARY.....	5
PERSPECTIVE.....	8
FOCUS ON SOUND ABSORPTION.....	9
Introduction.....	9
Current Technology.....	9
Panel Design Research.....	14
Covering Material Studies.....	14
Panel Core Consideration.....	27
The Impact of Placing a Cover Over the Absorbent Core in Terms of Acoustical Performance.....	30
Other Panel Considerations.....	37
Panel Spacing Studies.....	39
FOCUS ON SOURCE QUIETING.....	49
Introduction.....	49
Current Technology.....	50
The Chiller.....	50
The Lung Gun.....	61
The Hock Cutter.....	66
The Vent Cutter.....	69
Ice System.....	75
Vibration Monitoring.....	77
CONCLUSION.....	78
TEXT REFERENCES.....	80
BIBLIOGRAPHY.....	81
APPENDIX A - Burn Test on Temperkote®.....	A-1
APPENDIX B - Qualifying a Reverberant Test Room.....	B-1

LIST OF FIGURES

	<u>Page</u>
Figure 1 - Typical Design of Current Acoustical Panels.....	10
Figure 2 - Separated Seam After Washing.....	11
Figure 3 - Perforated Cover.....	13
Figure 4 - Test Panels in Plant.....	21
Figure 5 - Test Panels Being Sprayed in Plant.....	22
Figure 6 - Energy Spectrum for a 40-watt Fluorescent Light Fixture...	25
Figure 7 - Absorption Spectrum for Mylar.....	26
Figure 8 - Absorption Characteristics of Potential Panel Cores (1" Thickness).....	29
Figure 9 - Uncovered Panels Being Tested in Reverberant Chamber.....	31
Figure 10 - Percentage Change in Panel Absorption Coefficient Caused by Covering the Panel.....	35
Figure 11 - Typical A-Weighted Spectrum for Reverberant Noise Field in a Poultry Processing Plant.....	36
Figure 12 - Schematic of Panel Spacing Test.....	41
Figure 13 - Panel Absorption As a Function of Spacing (Uncovered Fiberglass).....	43
Figure 14 - Panel Absorption As a Function of Spacing (Fiberglass covered with 3 mil Melinex).....	44
Figure 15 - Spacing at Which Hanging Panels Have Comparable Absorptive Qualities per Square Foot of Surface Area Covered As Panels Placed Flat On Surface.....	45
Figure 16 - Schematic of Panel Spacing Test with Ceiling Panels Added.....	47
Figure 17 - Paddle Chiller.....	51
Figure 18 - Spectrum for Individual Components On a Paddle Chiller....	53
Figure 19 - Hood Mounted Over Pump Housing and Drive Motor.....	54
Figure 20 - Sound Energy Spectrum Changes in the Paddle Chiller.....	55
Figure 21 - Sound Energy Spectrum Changes in the Paddle Chiller.....	56

LIST OF FIGURES (Cont'd)

	<u>Page</u>
Figure 22 - Accelerometer and Microphone Locations for Chiller Analysis.....	58
Figure 23 - Giblet Chiller Undergoing Tests.....	59
Figure 24 - Sound Pressure Spectrum Changes in the Giblet Chiller.....	60
Figure 25 - Noise Contour in Plant with Lung Guns.....	62
Figure 26 - Noise Contour in Plant with Lung Guns Replaced with Drawing Machines.....	63
Figure 27 - Typical Lung Removal Area with Hand Held Lung Guns.....	64
Figure 28 - Lung Gun Hood.....	65
Figure 29 - Noise Contour in Plant with Hock Cutter.....	67
Figure 30 - Noise Contour in Plant with Hock Cutter Removed.....	68
Figure 31 - Accelerometer and Microphone Locations for Hock Cutter Analysis.....	70
Figure 32 - Partial Housing Placed Over Hock Cutter Drive Motors.....	71
Figure 33 - Sound Energy Spectrum Changes in the Hock Cutter.....	72
Figure 34 - Pneumatic Muffler Tested.....	73
Figure 35 - Sound Energy Spectrum Changes in The Vent Cutter.....	74

LIST OF TABLES

	<u>Page</u>
Table 1 - General Film Properties.....	15
Table 2 - Results of Film Tests.....	16
Table 3 - Comparison of Reinforced and Unreinforced Materials.....	18
Table 4 - Six Month Panel Endurance Test.....	23
Table 5 - Fire Characteristics of 1.9 oz Temperkote.....	27
Table 6 - Quoted Prices for Selected Cover Materials.....	27
Table 7 - Quoted Prices for Absorbing Core Material.....	28
Table 8 - Absorption Coefficient for Uncovered Fiberglass Panels....	34
Table 9 - Percentage Change in Panel Absorption Coefficient Caused by Covering the Panel.....	34
Table 10 - Seam Strength Tests Using 1.9 oz Temperkote.....	38
Table 11 - Absorption Coefficient of a Ceiling Surface Covered with Hanging Panels.....	46
Table 12 - Absorption Coefficient of a Ceiling Surface Covered with Hanging Panels.....	48

ACKNOWLEDGEMENT

We would like to express our appreciation to the following individuals whose assistance was invaluable to our research effort:

Abit Massey	Georgia Poultry Federation
Sandy Tingley	NASA Lewis
Charles Feiler	NASA Lewis
Ed Rice	NASA Lewis
Al Karchmer	NASA Lewis
Ray Gilbert	NASA Headquarters
Chet Austin	Tip Top Poultry
Buddy Burruss	Tip Top Poultry
Jim Burruss, Jr.	Tip Top Poultry
Luke Sauder	Weaver Poultry

In addition we would like to thank the following companies who supplied sample materials for evaluation:

E.I. DuPont de Nemours, Inc.
Howe & Bainbridge, Inc.
St. Regis Paper Co.
Eastman Chemical Products, Inc.
B.F. Goodrich
Oak Materials Group, Inc.
3 M Company
Conwed Corporation
Polycon, Inc.
I.L.C. Dover
Sheldahl, Inc.
Unitex
Armstrong Cork Co.
Rollins Inc.
Industrial Acoustics Company
Owens/Corning Fiberglas
Vertrod Corporation
Allforce Acoustics

RECOMMENDATIONS

A number of techniques can be used to reduce poultry processing plant noise. While the exact approach to solving a noise problem necessitates some understanding of the specific plant environment to be treated, in general covering the ceiling of a plant with a noise-absorbing medium is a practical first step. Once the reflected noise levels have been abated, then treatment of specific, identifiable noise sources can better take place. The logic behind this recommendation results from our earlier findings that much of the noise observed in a typical plant is caused by the poor acoustic qualities of the plant rather than the presence of numerous, loud noise sources.

In selecting a ceiling treatment, attention must be given to maintenance and replacement costs in addition to purchase and installation costs. Our study revealed a host of potential maintenance problems with noise panels if inadequate attention is given to the demands which will be placed on the covering medium during normal plant operations. Because the cover must remain intact to comply with USDA cleanability requirements, we recommend the use of rugged fiber-reinforced plastic covers to minimize the potential for failure. This results in a potentially higher panel cost but yields one which will last many years. We stress this because the cover is only a portion of the total cost which goes into panel construction, yet its failure renders the entire panel useless.

We also recommend that noise panels be suspended vertically from the ceiling. Our research showed a spacing of 3 feet between panels as a satisfactory spacing. However closer spacings can be chosen if the plant is

attempting to bring about a larger amount of noise reduction or trying to improve low-frequency absorption. By our calculations, the 3-foot spacings should provide a 5 to 6 dB reduction in reverberant noise level at the plants presented in our previous report.

With regard to source quieting, a key word must be maintenance. Improperly maintained machinery was one of the leading causes noted for high machinery noise levels. We found that poorly maintained machinery can be located using a portable vibration meter. This provides a means of initiating preventive maintenance which can lower machinery noise levels.

In addition, we recommend isolating drive motors and pumps from large, expansive surface areas, such as those on a chiller. For example, flexible connecting tubes between pumps and chiller bodies could mean a substantial reduction in local sound pressure levels near the chiller. Drive motors also can be placed under hoods filled with absorbing medium to reduce their sound power emission to the plant. Pneumatic devices should always be muffled. A large number of companies design inexpensive mufflers for just such an application.

Lung guns, on the other hand, remain a problem where they must still operate. The most logical solution is to contain lung gun noise through the use of partial plastic barriers between individual operator stations. However, this demands that an absorbing medium be placed over the station to prevent sound pressure buildup to the operator.

Lastly, ice chutes can be insulated for both energy conservation and abatement of noise related to ice transport and discharge. There are a number of

good vibration dampening mediums that are efficient thermal insulators as well.

SUMMARY

Industrial noise is a problem with untold potential consequences. High noise levels risk permanent hearing damage, low worker productivity, and poor employee/supervisor relations. It also may be a factor in worker turnover rates. In addition, Federal and State noise statutes require that certain maximum noise ceilings not be exceeded under threat of fine.

For the past two and one half years, the Georgia Tech Engineering Experiment Station has been studying noise generation and control as it relates specifically to poultry processing plants. This research was cosponsored by the National Aeronautics and Space Administration and the Georgia Department of Agriculture. The program took root through the efforts of the Georgia Poultry Federation.

After the first year and a half of investigatory studies, the Tech research team concluded that the poultry processing noise problem was caused by a few major noise sources allowed to permeate throughout the plant by reflecting off of the hard plant walls and ceilings. Subsequent research focused both on designing an absorptive medium to reduce reflections in a plant and on identifying ways to reduce noise at the source.

The absorbing medium found to be most cost effective for the poultry application is a panel composed of a fiberglass core and a tough, rugged, fiber reinforced cover which is impervious to water. By hanging a series of these panels throughout the ceiling of a plant, it is estimated that sound levels can be reduced by as much as 6 decibels in many plant areas. An important consideration in this research effort, however, has been the toughness of

the impervious cover. While a number of potentially acceptable plastic films are available, it was concluded that a reinforced design was critical if the panels were to withstand the abuse typical to normal handling. The study also revealed that using a hanging panel pattern versus placing the panels flat against the ceiling required one-third fewer panels to achieve similar absorption characteristics. This hanging orientation, it was also found, could be varied to allow increased absorption in the lower-frequency octaves.

With regard to source quieting, it was found that there is no substitute for a good maintenance program. Maintenance neglect was one of the most common reasons observed for loud source levels (be it worn bearings, lack of grease, etc). Preventive maintenance procedures utilizing portable vibration monitoring equipment is one method of reducing source levels. Nonetheless, there are machine designs which are either inherently noisy or which require frequent maintenance to keep them quiet. For these machines, isolation from the rest of the plant work area (where practical) and/or vibration isolation and dampening treatments are recommended.

Overall, it was concluded that isolating drive motors and pumps from chiller bodies is an effective method of reducing their noise outputs. Absorptive hoods also can provide relief from inherently loud drive motor arrangements, both on chillers and rock cutters. No practical modification was found for the hand-held lung gun. Installation of barriers between lung removal stations does appear to be a potentially effective containment measure. However, it was determined that the barriers could not serve to isolate operators and an absorptive hood should be positioned over the station to minimize sound buildup. Pneumatic mufflers on hand tools were found to be

essential, and energy conservation provided excellent additional justification to insulate ice transport and discharge networks with sound dampening mediums.

PERSPECTIVE

This study was undertaken to identify practical solutions to the noise problem in poultry processing plants. To date, there has been only moderate activity in the area of abating poultry processing noise. Progress has been slow and many quieted designs have not proven satisfactory either in performing the functions they are required to perform or in withstanding the harsh working environment of the plant. Our research sought to remedy some of these problems.

The report is divided into two major parts:

1. Sound Absorption Investigations
2. Source Quieting Investigations

Each section provides a brief overview of selected activities known to be ongoing in that area along with a presentation of our research to find workable solutions to the problem.

There is no single remedy for the noise problem in poultry processing plants, rather a series of remedies, each having its own advantages and disadvantages. Unfortunately, the contribution of each remedy in reducing overall noise in a particular plant will depend on the noise sources in that plant and the plant layout. However, there is little doubt that the solutions described herein can contribute significantly toward reducing the general noise levels in most processing plants. More importantly, these solutions are durable and should not interfere with current operations.

FOCUS ON SOUND ABSORPTION

Introduction

Reverberation plays an important role in the noise problem associated with poultry processing plants.¹ Acoustical panels, to reduce reflected noise, have been used experimentally in plants but have encountered durability problems when the protective covers tear. Protective covers, it should be pointed out, are necessary to bring conventional absorbing materials (such as fiberglass or foam) into compliance with USDA cleanability requirements for use in a plant.

This section summarizes our efforts to determine the reason for current panel problems and to develop designs capable of enduring the types of abuse typical to the poultry processing environment while being effective in reducing plant noise.

Current Technology

We are aware of only a few companies today who are experimenting with absorbing panels specifically for use in poultry processing plants. The typical panel design is a fibrous or porous material covered with a plastic film which has been heat sealed and/or flame bonded (see Figure 1).

The absorbing media typically are fiberglass, mineral wool, or foam. The plastic covers, all of which are thin (between 0.5 mil and 2 mil in thickness), are either polyolefin or polyvinyl fluoride (PVF). This latter film (typically Tedlar®) has grown in popularity among panel builders.

PLASTIC COVER

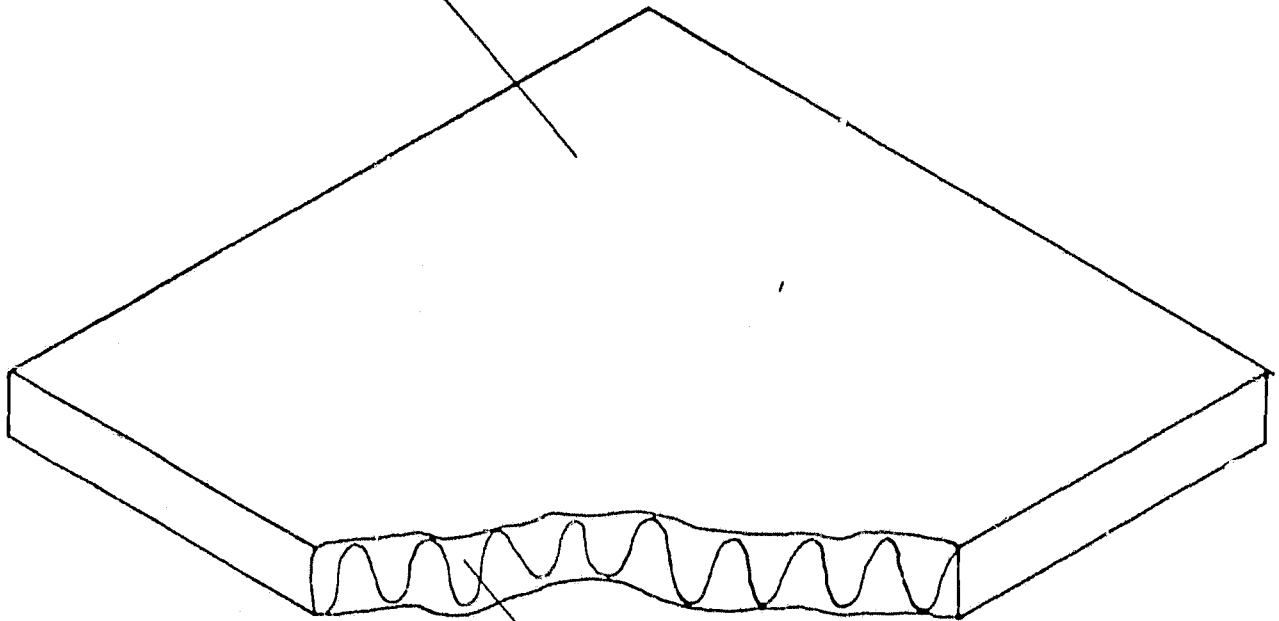

ACOUSTICAL MATERIAL

Figure 1 - Typical Design of Current Acoustical Panels

Because the cover of a panel is critical to its survival in the poultry processing environment, we devoted a great deal of attention to seeking materials and designs which lower the risk of cover failure from abusive handling. It was not our goal to design a panel which could not be destroyed through abuse, but rather to evaluate alternatives in cover ruggedness to determine which, if any, panel design might work given both USDA cleanability constraints and the very nature of the harsh cleaning and maintenance procedures typical to the poultry processing industry.

In evaluating the experimental panels currently being developed specifically for poultry processing plants, we discovered, through a series of informal tests, that one panel had a major weakness in its heat-sealed seam. When the panel was sprayed with high-pressure water during routine cleanup, the seam separated and the cover sheared off (see Figure 2). A similar panel design, by another firm, had a reversed seam which was capable of withstanding high-pressure water contact. We must add that tape has since been added to the seam of the first design, which does seem to offer the necessary reinforcement required.

Another common flaw we found in these experimental panels, however, was actually a characteristic of the PVF film itself. PVF film is strong, yet unusually susceptible to perforation (see Figure 3). This typically results in a total failure of the cover once perforated, due to the poor tear strength of the film.

These two findings served as a starting point for our research into a better panel design.

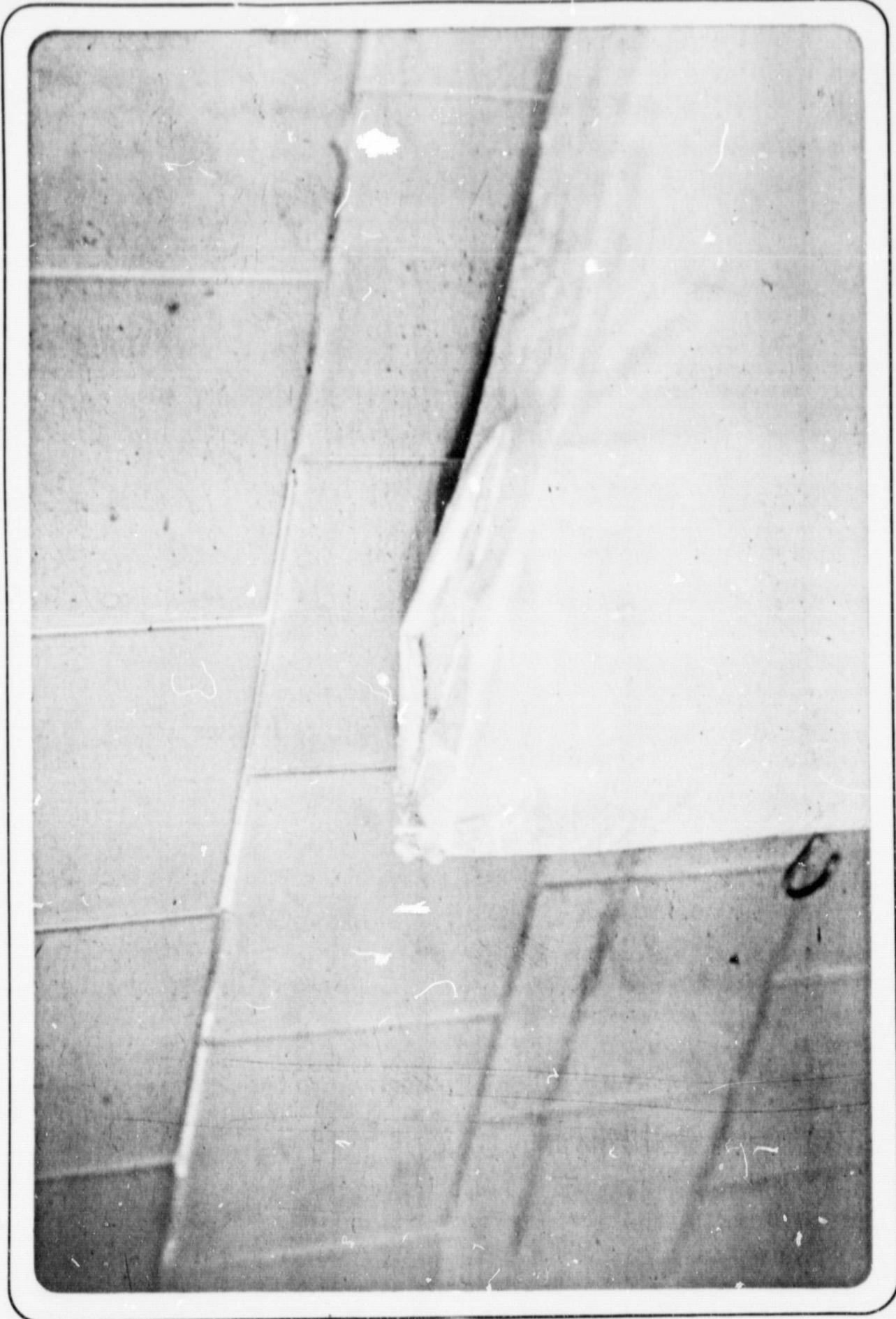

Figure 2 - Separated Seam After Washing



Figure 3 - Perforated Cover
-13-

ORIGINAL PAGE IS
OF POOR QUALITY

Panel Design Research

In evaluating methods of providing a better panel, we looked at the strength of different covering materials, the absorption characteristics of the panel core, and the effect the cover had on the panel core absorption. Panel costs were also considered from the standpoint of overall cost minimization.

Covering Material Studies

There are a number of ways to improve the strength of a panel cover:

1. Use a stronger material.
2. Protect the cover with a shield.
3. Use thicker material.

We first focused our attention on stronger materials. Realizing that PVF film was the most commonly used covering material, we looked for materials with superior qualities to it. Table 1 presents the pertinent physical properties of several general film categories. From this table we observed that polyester film offered superior tensile strength to PVF film while having comparable tear strength. Polyurethane film, on the other hand, offered superior general tearing strength to PVF film while having comparable shear strength.

In order to evaluate these properties in a commercial product, we acquired 1 mil samples of Du Pont Tedlar® (a PVF film), Du Pont Mylar® (a polyester film), and B. F. Goodrich Tuftane® (a polyurethane film). The tests conducted were:

1. Tensile Strength - This test (comparable to ASTM D882-79) provided a general measure of the overall strength of the film. It involved

Table I

GENERAL FILM PROPERTIES

	<u>Polyethylene</u>	<u>PVC</u>	<u>PVF</u>	<u>Polyester</u>	<u>Polyurethane</u>
Tensile Strength (psi)	1,500-6,100	1,400-16,000	7,000-18,000	20,000-40,000	5,000-12,000
Tearing Strength					
Initial (lb/in)	65-575	110-490	997-1,400	1,000-3,000	350-600
Propagating (g/mil)	50-300	60-1,400	12-100	12-17	220-710
Resistance					
Grease & Oil	poor to good	good	good	good	good

Source: Modern Plastics Encyclopedia, 1979-79

taking 1-inch strips of each sample, placing them in the jaws of a gripping apparatus, and applying a pulling force until the sample failed.

2. Tear Strength - This test provided a measure of the strength of the film to shearing once a tear was initiated. It involved mechanically initiating a slit in a sample and then applying a pulling force to continue the tear through failure.
3. Burst Strength - This test measured the strength of the material to concentrated forces. It involved mounting the test sample on a small port on the side of a water-filled cylinder and gradually increasing the water pressure in the cylinder until the sample began to release water.

Table 2 presents the test results on the three samples.

Table 2
RESULTS OF FILM TESTS

	<u>Tensile Test</u> <u>(lbs force)</u>	<u>Tear Test</u> <u>(lbs resistance)</u>	<u>Burst Test</u> <u>(psi)</u>
1 mil Tedlar®	10.1	0.1	41
1 mil Mylar®	15.3	0.1	58
1 mil Tuftane®	2.6	0.8	43

From these tests, we observed that the urethane film we had selected did not exhibit tensile strength comparable to the PVF film, but that the other relationships were indeed similar to the general properties in Table 1. We

concluded, therefore, that of the three products selected, Mylar® was the best covering medium candidate, from a strength standpoint, although we were disappointed in its tear strength.

We next looked at reinforced films to determine if suitable strength and tear characteristics could be found. The most commonly used technique for reinforcement is adhering a film to a thin cloth. Such a composite is used for vapor shields by the aerospace industry.² Initially we were unable to find such a product commercially available, so we constructed our own (calling it the EES composite). The materials we selected were Du Pont Mylar® film (1 mil) and dacron cloth (40 denier). We bonded the two together using a latex glue. No sooner had we fabricated this composite, however, than we found a sailcloth manufacturer who had an experimental composite product called Temperkote® which was made of Du Pont Mylar® and rip stop nylon. Their product was similar to our test sample, yet offered the additional advantage of being commercially available.

We began an immediate evaluation of both samples. Utilizing the test procedures referenced above, we generated information on the strength characteristics of each sample. In order to maintain a comparison basis for these dissimilar test samples, we weighed each one. The reinforced films, we found, had a weight per square foot similar to that for a 2 mil unreinforced film. To provide a comparative link for our strength studies, we therefore tested a 2 mil sample of ICI Americas Melenax® (a polyester film), since at this point we felt polyester film represented the best unreinforced covering material. Table 3 presents the test results.

Table 3

COMPARISON OF REINFORCED AND UNREINFORCED MATERIALS

	<u>Tensile Test</u> (lbs force)	<u>Tear Test</u> (lbs resistance)	<u>Burst Test</u> (psi)
2 mil Melinex®	36.7	0.1	102
EES Composite	35.8	1.6	120
1.9 oz Temperkote®*	38.3	5.8	125

*Approximate weight per square yard of material.

From these data we concluded that both of the composites had tensile strength similar to the 2 mil polyester film but significant tear strength advantages. We were satisfied that this represented a significant advantage and therefore were inclined to list the composite as the better cover medium from a strength standpoint.

We also looked at one additional method of reinforcing films, namely, scrimming. Scrimming is a term used to define the bonding of a netting material either to the back of a film or between two films. Most of the scrimms we studied were experimental in nature, usually employing nylon or fiberglass netting and a PVF film. While the concept offered tear strength advantages over unscrimmed films, we found that the film in unsupported areas of the netting remained vulnerable to failure and hence offered no significant advantage over the composite.

Before leaving the subject of material properties, we conducted one additional test on the six test samples studied. As mentioned earlier, PVF film exhibits a low resistance to perforation if scrapped, and any contact with the film can result in a scratch or slight perforation. Once perforated, as our

own tests proved, the film has little resistance to tear propagation. We therefore conducted an abrasion test on each of the six samples in Tables 1 and 2 to determine their relative strength. The test involved rotating a sample 1,000 times against a rough surface. Our tests resulted in none of the samples, other than Tedlar®, failing. The Tedlar® sample failed after only about 10 revolutions. Therefore, we were satisfied that all of the films being studied offered a significant advantage over PVF film in this regard.

We next focused on methods of protecting the cover with a shield. We investigated two methods of providing this protection:

1. a screen
2. a perforated plate

Neither of these methods was particularly attractive because of the problems associated with cleaning them.

The screen we selected was made of polypropylene, which is both non-corrosive and inexpensive. We selected a 6 x 8 strand per inch pattern for evaluation. Conferring with the United States Department of Agriculture (USDA) field office in Atlanta, we gained approval to test a panel with a PVF film cover and a screen on the outside in a plant. After nearly six months of exposure, the sample remained relatively clean. However, we must point out that had the panel come in contact with blood, feathers, etc., cleaning would have been difficult without removing the screen.

We also evaluated a perforated plate design. Unfortunately, the only commercial design we could acquire was a box design made of steel. The difficulties we encountered in sealing the box so as to eliminate food entrapment

forced us to consider putting the film on the outside of the box, thereby defeating the box's protective qualities. Since the perforated plate designs we reviewed were also expensive, we chose to eliminate it from further consideration.

We lastly focused on utilizing a thicker film material to increase cover strength. In order to learn if there was a minimum satisfactory thickness for use in the poultry environment, we decided to experiment with different panel covers in an actual poultry application. We constructed panels with covers of four different thicknesses (1, 2, 3, and 5 mil). Based on our earlier work, we also decided to evaluate simultaneously the different materials studied: Tedlar®, Mylar®, Melineax®, Tuftane®, the EES cloth/film composite and, as mentioned above, a polypropylene screen covered PVF film. The four thicknesses were evaluated on polyester film only.

The samples (eight in all) were made using a fiberglass core material, and the panels were hung at Tip Top Poultry in Marietta, Georgia. The mounting arrangement placed the panels low enough to the floor (approximately 10 feet) to insure their being washed daily (see Figures 4 and 5). The test lasted six months. Test results are presented in Table 4.

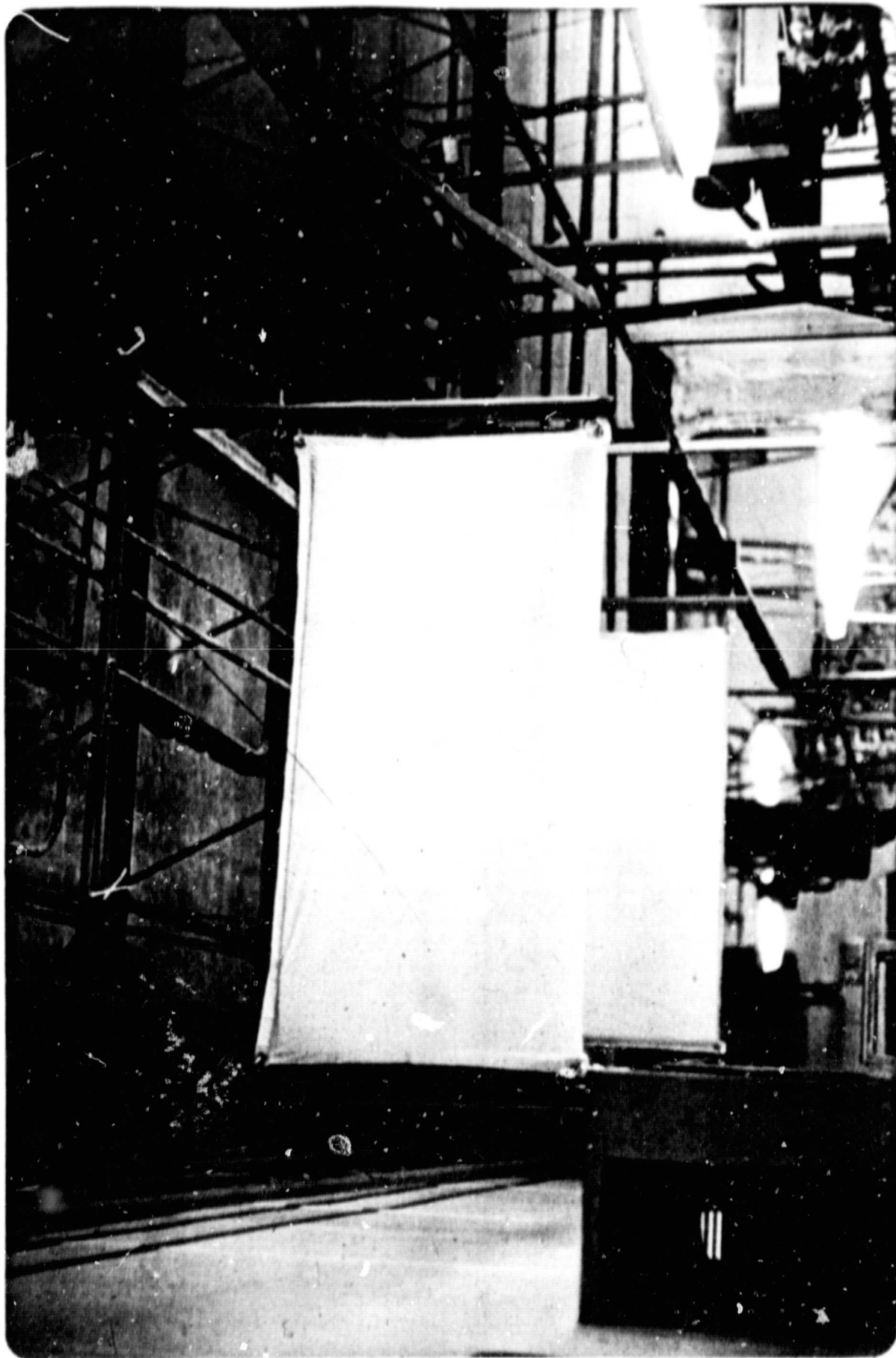

Figure 4 - Test Panels in Plant



Figure 5 - Test Panels Being Sprayed in Plant

Table 4

SIX MONTH PANEL ENDURANCE TEST

<u>Panel Cover Material</u>	<u>Test Result</u>	<u>Explanation</u>
1 mil Tedlar®	failed (after 4 mo.)	corner pulled away
1 mil Tuftane®	failed (after 1 day)	corner pulled away
1 mil Mylar®	failed (after 1 mo.)	corner pulled away
2 mil Melinex®	survived test	
3 mil Melinex®	survived test	
5 mil Melinex®	survived test	
Polypropylene screen over 1 mil Tedlar®	failed (after 5 mo.)	a rip in the film developed on the panel's bottom edge
EES film/dacron composite	survived test	

From this test, we concluded that a 1 mil cover is simply too thin for long-term exposure in a poultry processing plant. We made this conclusion realizing that the conditions of abuse were highly variable between panels and hence did not provide precise failure information regarding the four panels that did fail. We therefore ruled out attempting to draw conclusions regarding individual material-to-material strength characteristics for the various 1 mil panel covers.

Based on the investigations described above, we concluded that a fiber reinforced cover (such as Temperkote®) was the best all-around covering material of those studied. We sought, at this point, to answer two additional questions regarding the Temperkote® material in particular:

1. Could it endure continuous exposure to industrial lighting?
2. Was it a fire hazard?

The first question evolved from documented evidence that neither untreated Mylar® nor nylon can resist degrading if exposed for prolonged periods

to sunlight. However, when the light spectra of typical industrial fluorescent lighting are viewed, there is a noticeable absence of ultraviolet energy (see Figure 6), which is absorbed by both Mylar® and nylon (see Figure 7) and eventually leads to their degradation.³ While considerable debate was found regarding the possible life of the composite under continuous lighting exposure, nearly every expert contacted agreed the product should last several years at worst.

In order to reinforce these opinions, we conducted a light exposure test. Placing a sample of the Temperkote® around a 25-watt fluorescent light fixture, we subjected it to over 4,100 hours of continuous light exposure. Due to the direct placement of the film on the bulb, the light energy concentration was several orders of magnitude greater than that typical for panels in an actual plant situation. This high-energy-intensity exposure was expected to accelerate any degradation that might occur, thereby compensating for the short time duration of the test. The test ended with no noticeable change in material property strength. We concluded, therefore, that the material was suitable for long-term exposure to industrial lighting without displaying significant degradation.

The second question came from a concern for placing large quantities of this material in a plant without having any information on its burning characteristics. Tests were conducted on the composite film using the ASTM E 84-80 test for developing surface burning characteristics of building material. This test is recognized nationally as a means of classifying materials for use in industrial building applications. Appendix A provides more specific information on the test. The test results are shown in Table 5.

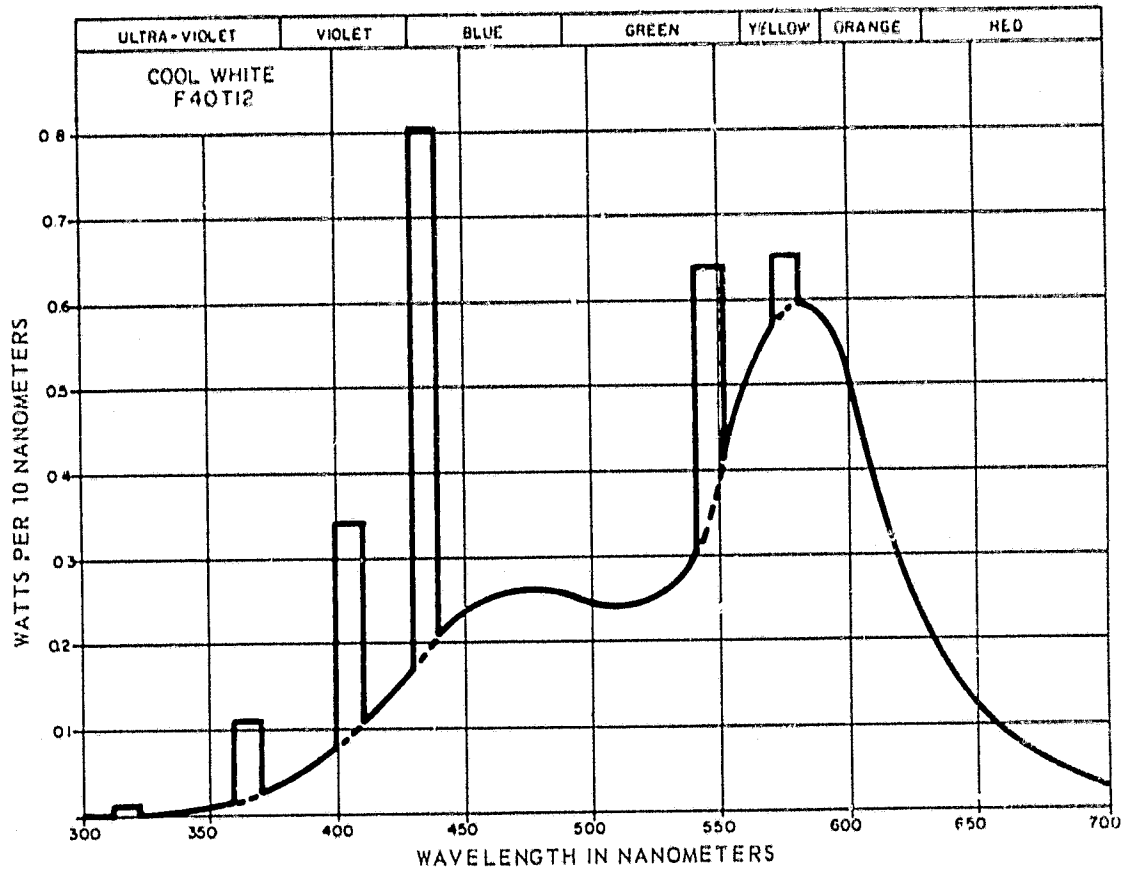

Figure 6 - Energy Spectrum for a 40-watt Fluorescent Light Fixture

Source: GTE Sylvania Engineering Bulletin O-283

ABSORPTION SPECTRUM FOR "MYLAR"
(low range)

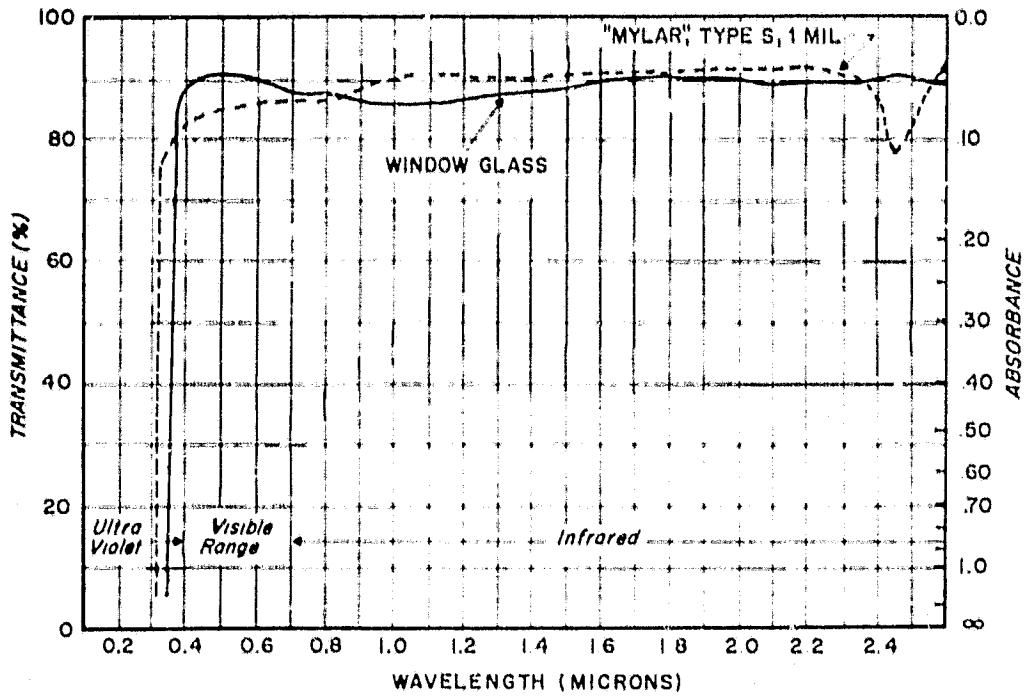

Figure 7 - Absorption Spectrum for Mylar

Source: DuPont Bulletin M-5C

Table 5
FIRE CHARACTERISTICS OF 1.9 OZ TEMPERKOTE[®]

Flame Spread Index	10
Smoke Development Index	25

These results indicate that the composite does not offer any unusual fire risk. In fact, the test rating for the product is class A (the best obtainable). Nonetheless, these tests do not check the material in an orientation similar to that in which it will be used. Consequently, we still feel that caution should be exhibited in drawing conclusions about the flammability of the film in use. What this test does do is compare the film to other materials commonly used in the construction of industrial plants, and does so under controlled, consistent test conditions.

Just as there were differences in the strength of the cover materials studied, so also there were differences in the price of each. Table 6 presents prices obtained for three of the six samples studied.

Table 6
QUOTED PRICES FOR SELECTED COVER
Materials (1980 prices)

1 mil Tedlar [®]	7¢/sq. ft.
1 mil Mylar [®]	3¢/sq. ft.
1.9 oz Temperkote [®]	37¢/sq. ft.

Panel Core Consideration

In selecting a core material to use in a panel, we evaluated three candidates:

1. fiberglass
2. urethane foam
3. felt

Our criteria for selection were cost, absorption characteristics, and acceptability by USDA for use, realizing that if and when a cover tears, the core is at least momentarily exposed.

Focusing first on cost, we compared three products currently available on the market:

1. Owens-Corning semi-rigid fiberglass
2. Allforce polyurethane foam
3. Scott polyurethane felt

Other companies were checked to assure that the price figures for these products were representative. The cost figures appear in Table 7.

Table 7

QUOTED PRICES FOR ABSORBING
CORE MATERIAL (1980 PRICES)

Owens Corning Fiberglas® 703 semi-rigid board (2" thick - 2' x 4')	\$0.56/sq. ft.
Korfund Noiseguard (foam absorber F-500) (2" thick roll 54' wide x 50' long)	\$1.45/sq. ft.
Scott Industrial Foam Scottfelt (2 1/2-900) (2" thick - 2' x 4')	\$9.00/sq. ft.

Next, we reviewed the absorption characteristics of these three products

Red - Scottfelt (felt)
 Blue - Noiseguard (foam)
 Black - Fiberglass (fiberglass)

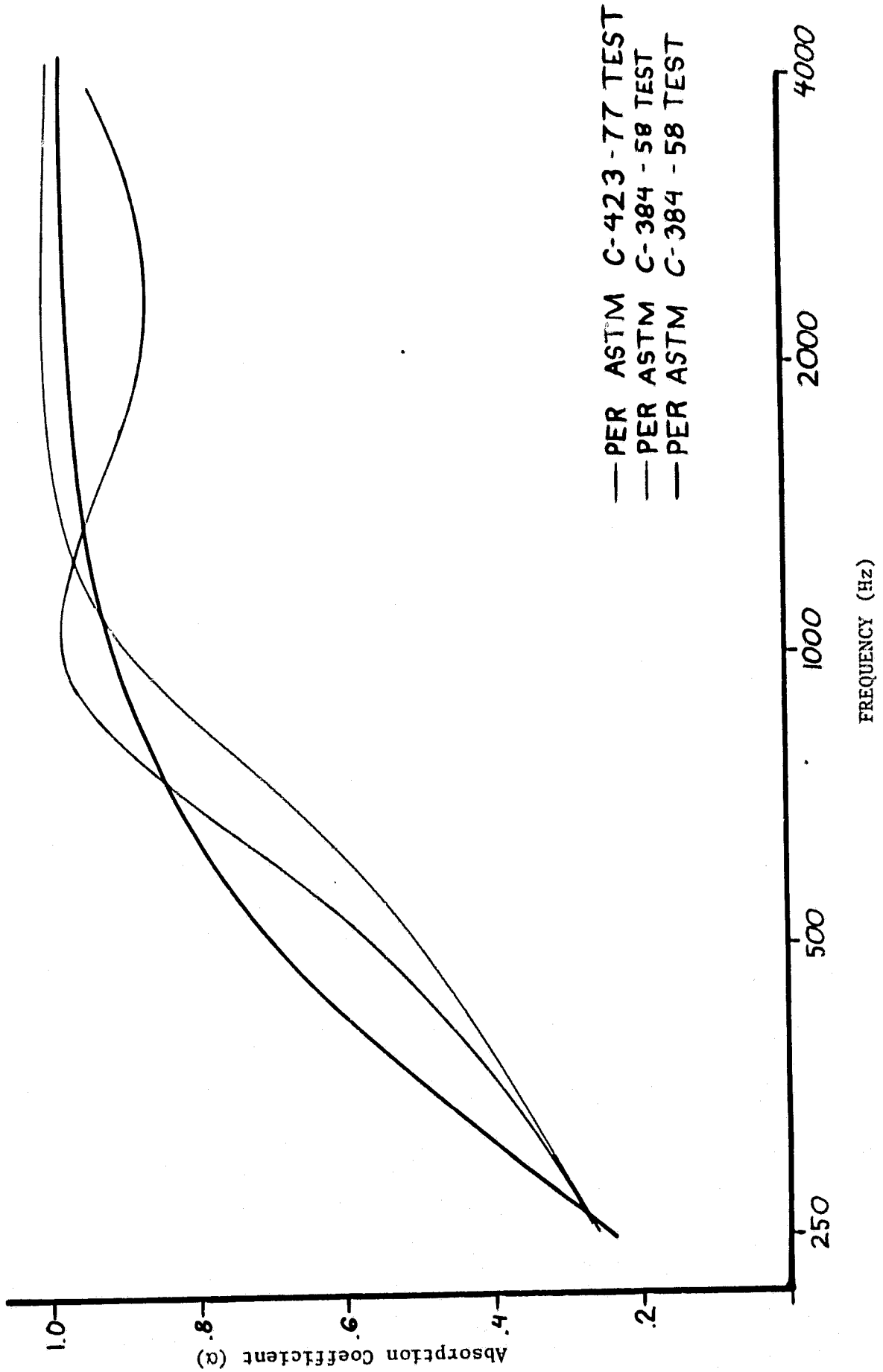

Figure 8 - Absorption Characteristics of Potential Panel Cores (1" Thickness)

based on published data. In order to utilize published data and still make an equal comparison, we had to look at a 1" thick product. The data are shown in Figure 8. It must be pointed out that this information was developed by the manufacturer. Two of the manufacturers used the impedance tube method, which measures normal incidence performance. They then corrected the data for random incidence performance. The third manufacturer used the reverberant room test method, which measures random incidence performance.

Because of this difference in test procedure, a precise comparison of product performance is difficult. What the data do show, however, is that none of the products offer a clear absorptive advantage over the others. Granted, the specific data do show octave band absorption differences, but given the differences in procedure that were used, it is doubtful these could be called significant.

Lastly, we reviewed the acceptability of these products by USDA. The Washington office of the USDA told us that none of the generic products contained toxic components and therefore could be used in a poultry application. Discussions with local inspectors confirmed this position stressing however that any panel with a ripped cover would have to be removed immediately.

Based on the three aspects mentioned above, we selected fiberglass as the most cost-effective absorbing medium of the three evaluated.

The Impact of Placing a Cover Over the Absorbent Core in Terms of Acoustical Performance

We conducted a series of tests designed to determine the acoustic effect of covering a sound-absorbing panel with various protective coverings. The

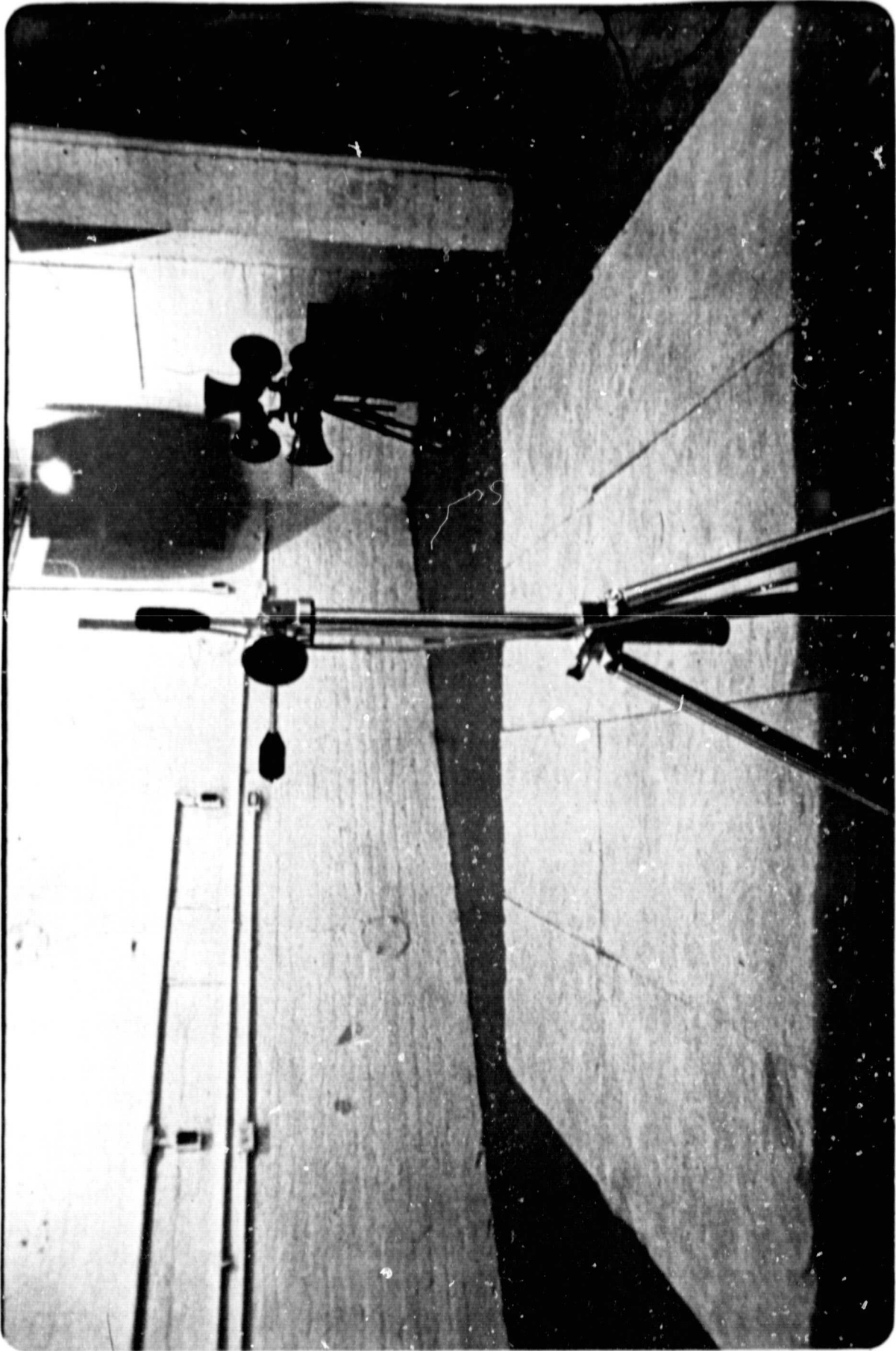

Figure 9 - Uncovered Panels Being Tested in Reverberant Chamber

test procedure involved using eight 2' x 4' x 2" series 703 semi-rigid Fiberglas® insulation boards from Owens-Corning. The panels were placed on the floor of a reverberant test chamber (see Figure 9). The sound absorption coefficients for the uncovered panels were determined, and a comparison was made of the change in the sound absorption coefficient when the panels were covered with different films.

The test methodology utilized in evaluating the effect of protective covers on the acoustical absorption of a fiberglass core was the reverberant decay method (ASTM C423-77). Prior to conducting the test, we modified a building on the Georgia Tech campus to serve as our test chamber. (See Appendix B, which discusses our qualification tests.)

To determine the absorption coefficient of the test panels, a loudspeaker system was fed by a B&K 4205 octave wide noise source to develop a steady-state diffuse field in the chamber. Reverberant levels reached were 110 dB for the 250 and 4000 Hz octave and 125 dB for the 500, 1000 and 2000 Hz octaves. The noise signal was left on for about two seconds to insure that a diffuse steady-state field had been set up in the chamber. The signal was then abruptly cut off, and the decay of the sound field picked up by a microphone and recorded onto magnetic tape. The analysis of the decay rate was performed by playing the tape-recorded signal back through an additional octave filter and into a true RMS detector. A Hewlett-Packard 5420-A spectrum analyzer, in the time record mode, displayed the decay as sound pressure level versus time. This display was transferred to paper by a chart reader. A best-fit line was then drawn through the decay portion of the curve starting 5 dB down from the beginning of the decay and extending to a point that was 15 dB

above the noise floor of the measurement. This usually resulted in 25 dB to 30 dB of range, which was then extrapolated to the time required for 60 dB of decay to occur. Six decays at each octave band were charted and an average decay time calculated. The standard deviation of the measurement samples was also calculated to indicate the measurement uncertainty.

The absorption of the test chamber empty and with panels was calculated using the following formula:⁴

$$A = \frac{.9210 \times V \times 60}{C} \times \frac{1}{T}$$

where

V = volume of the chamber (ft³)

C = speed of sound (ft/sec)

T = average decay time for a 60 dB drop in sound pressure level in the room (sec)

The absorption of the test specimen alone (A_T) was then calculated using the following formula:⁵

$$A_T = A_1 - A_2$$

where

A₁ = The absorption of the test room with panels

A₂ = The absorption of the test room empty

The absorption coefficient (α_T) of the test specimen was next calculated using the following formula:⁶

$$\alpha_T = \frac{A_T}{S_T} + \alpha_1$$

where

A_T = The absorption of the test sample (Sabines)

S_T = Surface area of the test specimen (ft²)

α₁ = Absorption coefficient of the floor area covered by the test specimen

The absorption coefficients obtained on the uncovered fiberglass panels are shown in Table 8.

Table 8

ABSORPTION COEFFICIENT FOR UNCOVERED
FIBERGLASS PANELS (2" THICK, SERIES 703)

Octave (Hz)	250	500	1000	2000	4000
α	.661	.798	.824	.766	.605

We hasten to note that our values are significantly lower than those reported by the manufacturer, but a difference in measured values is not uncommon between two different reverberant rooms. Our goal in reporting these absolute values is to allow subsequent evaluations. We make no challenge of the manufacturer's reported values.

Listed in Table 9 are the percentage changes in absorption coefficient observed for the fiberglass panels using different covering materials.

Table 9

PERCENTAGE CHANGE IN PANEL ABSORPTION
COEFFICIENT CAUSED BY COVERING THE PANEL

Material	Octave				
	250	500	1000	2000	4000
Mylar® (1 mil)	13.5	0.88	0.0	-2.87	-10.2
Mylar® w/screen (1 mil)	-8.17	4.14	-2.67	-9.01	-11.2
Melinex® (2 mil)	-2.12	2.25	-9.71	-18.4	-42.5
EES composite	8.58	0.80	-9.91	-23.9	-44.7
Temperkote® (1.9 oz)	17.2	2.8	-4.38	-9.68	-38.8
Melinex® (3 mil)	3.03	4.64	-11.77	-29.5	-57.0
Melinex® (5 mil)	17.2	-2.13	-29.4	-43.7	-71.9

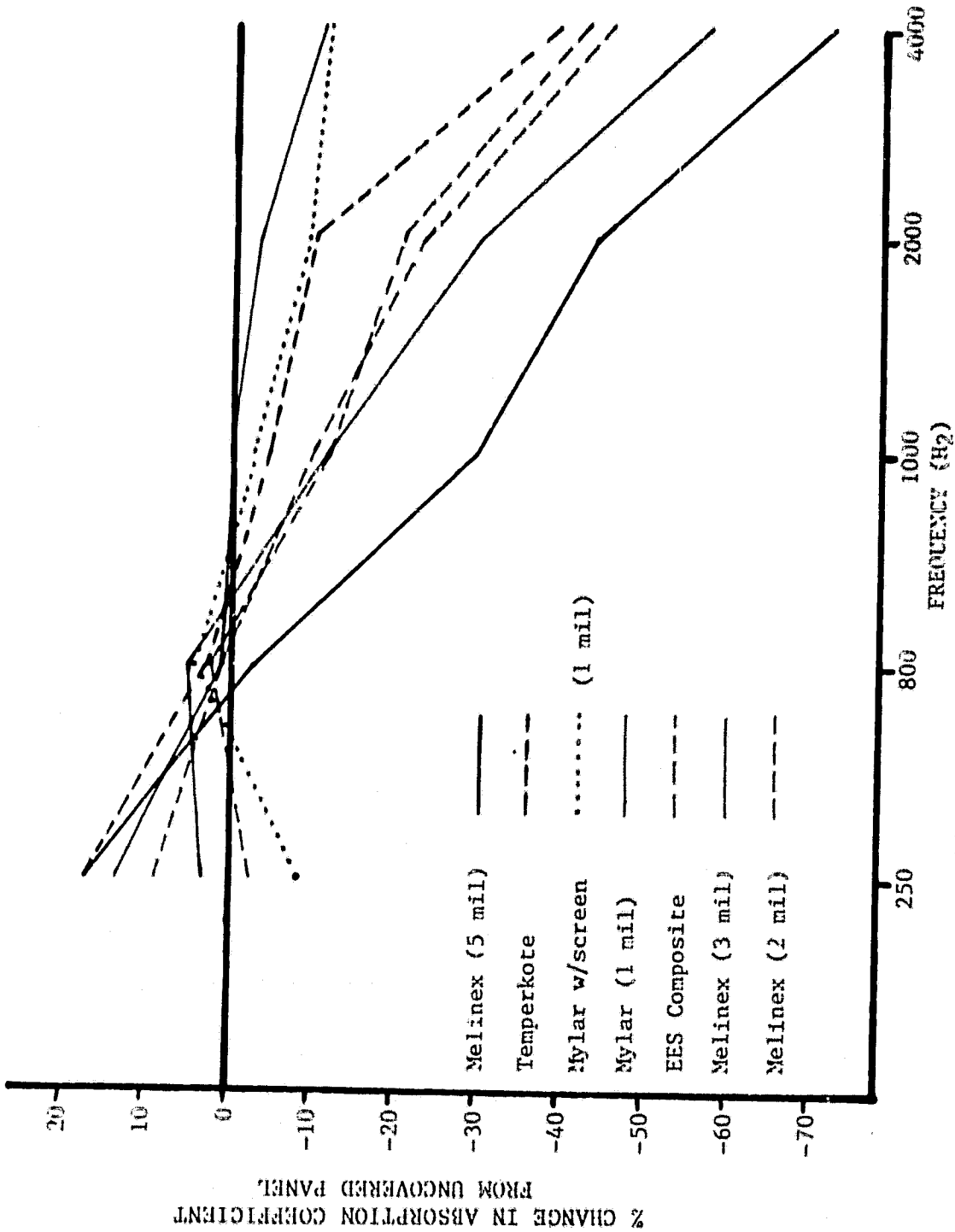
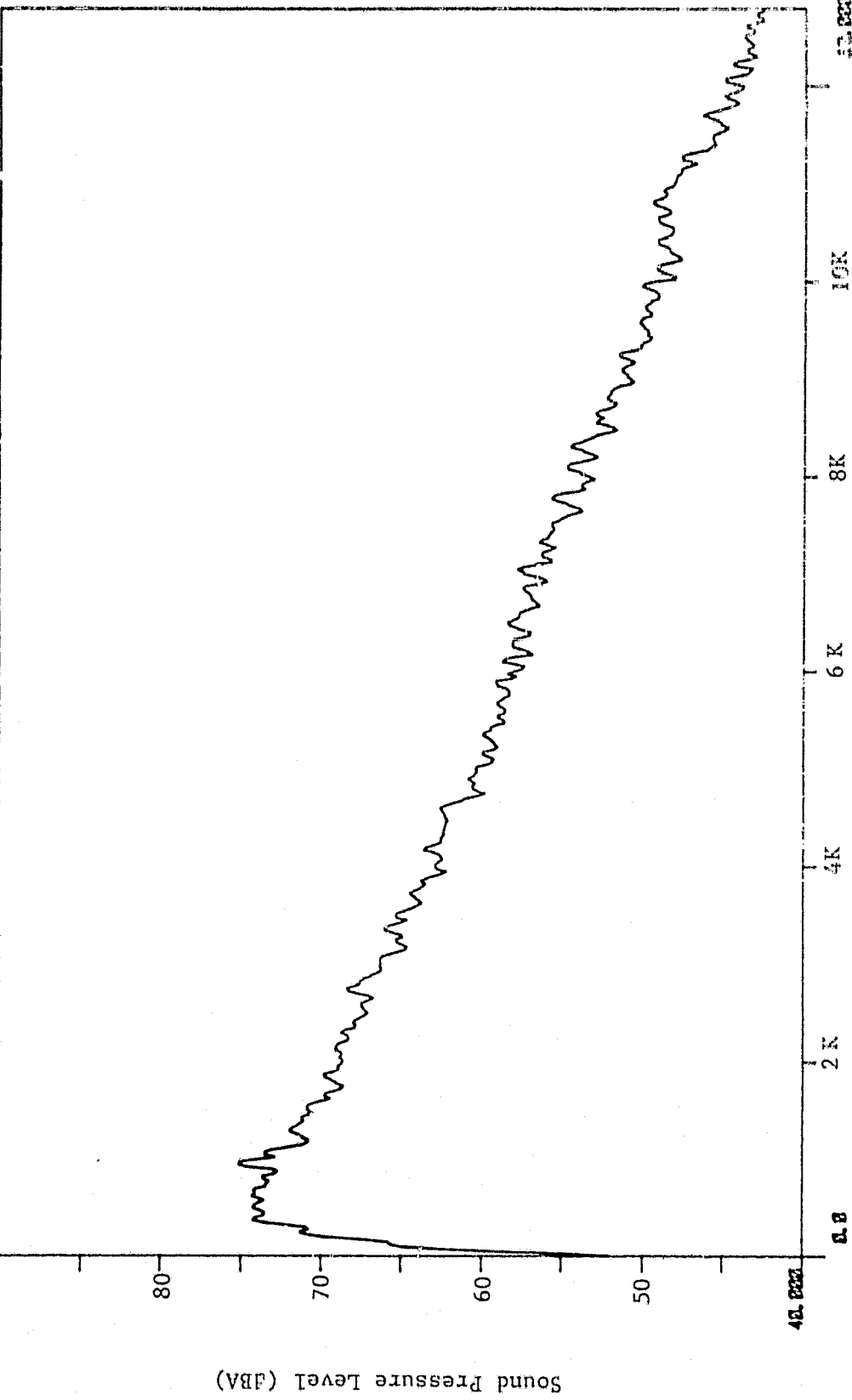

Figure 10 - Percentage Change in Panel Absorption Coefficient Caused by Covering the Panel

#A 123 EXPAND

A SPEC 1
90.000



FREQUENCY (Hz)

Figure 11 - Typical A-Weighted Spectrum for Reverberant Noise Field in a Poultry Processing Plant

These values are graphically plotted in Figure 10. They exhibit an interesting phenomenon. At lower frequencies, a thicker cover enhances panel absorption, while at higher frequencies a thicker cover diminishes panel absorption. This phenomenon is explained when the covering material is viewed as a driven oscillator transmitting sound energy to the core. The amplitude of oscillation is controlled by stiffness, resistance and mass. The degree of stiffness enhances the amplitude of oscillations at lower frequencies because of the inverse relationship of frequency and mechanical impedance. This overrides the mass damping impact. At higher frequencies, this is not true, and therefore, mass diminishes the amplitude of the oscillation.⁸

Because these panels must absorb noise specific to the reverberant sound field of a poultry processing plant, we reviewed the sound pressure frequency spectrum typical for such plants. Figure 11 presents a typical A-weighted spectrum. From this figure, it is obvious that the panels must be optimally effective between 250 and 2500 Hz. From Table 9 and Figure 9 it appears that a cover of greater thickness than 3 mils substantially diminishes absorption for all frequencies over 1000 Hz. Below 3 mils, however, it does appear as though the panels retain suitable absorption to allow sensible tradeoffs for strength. Based on our earlier strength research, we continue to remain convinced that a fiber reinforced cover, such as Temperkote®, is the best overall covering medium.

Other Panel Considerations

In addition to cover strength, we became concerned with the strength of the panel seam as well. As mentioned in our discussion of current technology, the

seam can prove to be the weak link in a panel design. This became particularly obvious to us during our endurance test at Tip Top Poultry. The panels installed in that plant were taped with two-sided Mylar[®] tape (3M brand #41b). After one week of exposure in the plant, we observed that the tape was beginning to separate from the inside of the seam (interior of the panel) out. After the full six months of exposure, none of the seams had failed, but the early separation forced us to consider different seaming techniques. The three techniques considered were:

1. two sided tape
2. heat seal
3. stitching

We made up 1" wide samples of 1.9-oz Temperkote[®] using each seaming technique. Two taped seams were studied, one employing the Mylar[®] double-stick tape already mentioned and the other a special high-adhesive double-sided tape (3M brand ISOTAC #Y-9460). The heat seal was a 1/4" wide seal produced by a Vertrod[®] heat sealer. The stitching employed polyester thread. Using the tensile test described earlier, we applied a pulling force evenly distributed along the entire seam and measured the failure point of the seam. Table 10 presents the test results.

Table 10

SEAM STRENGTH TESTS USING
1.9-oz TEMPERKOTE[®]

	<u>Failure Load</u>
Mylar [®] tape	1.77 lbs
ISOTAC tape	1.38 lbs
Vertrod [®] heat seal	6.60 lbs
Stitch	4.19 lbs

It should be added that the heat seal exhibited some brittleness near the edges of the seam. Also the thread actually failed in the test, thereby exhibiting the strength characteristics of the thread used in the stitching.

While we make no recommendations on seaming technique, we feel it is important to note the effect different techniques can have on cover strength. Obviously, when the maximum load a seam will be asked to take is unknown seam selection should tend towards the highest strength obtainable, limited only by the strength ceiling of the material being bonded.

Panel Spacing Studies

When placing panels in the ceiling of a plant, a number of possible mounting techniques may be used. Perhaps the most straightforward is to mount the panels flat against the ceiling. However, if the panels are hung vertically from the ceiling, more surface area is exposed, thus increasing the total sound absorbing potential of a single panel.

There have been several studies on hanging configurations of panels.⁹ Our tests were designed to measure the relationship between spacing and absorption when covering is added to a panel. It was hoped that by varying the distance of the spacing between hanging panels, improved low frequency absorption could be obtained.

The tests were conducted in the reverberant test chamber described in Appendix B. The test procedure involved hanging 2" thick, series 703, 2' x 4' Fiberglas® panels and two 1" thick, series 703, 2' x 4' Fiberglas® panels from the ceiling in the center of the test chamber. The panels were positioned face

to face and were spaced at equal intervals. The 1" thick panels were placed on the ends of the spaced arrangement and 1/2" thick plywood sheets were placed against the outside face of each 1" panel (see Figure 12). This prevented the outside face of these exterior panels from distorting the measured differences in total absorption resulting from spacing variations. The 1" thickness of the outside panels when placed against the plywood gave them an effective thickness of 2" on the interior, complementing the other 2" interior panels.

The panels were tested at 6", 1', 2', 3', and 4' spacings. Because of limitations in room geometry, one of the three interior panels had to be removed when going from a 3' to 4' spacing to keep the length of the arrangement at 12'.

The tests were conducted on both uncovered Fiberglas® panels and on panels covered with 3 mil Melinex®. The use of 3 mil Melinex® as the cover material was based on our earlier assessment that it represented the maximum cover thickness that could be used without significantly impairing panel acoustic performance in the 250 to 2500 Hz bandwidth.

The test results were evaluated from two angles. First, the total change in absorption (sabins) noted during the tests was divided by the area of ceiling displaced by the hanging panels. This evaluation provided a measure of the improvement in the reflecting surface absorption when it was covered with the hanging panel arrangement. These values are presented in Table 11. Next, the total change in absorption (sabins) was divided by the number of panels used in the hanging pattern. This evaluation provided a measure of the effectiveness of each panel in contributing to the total absorption observed. These values are presented in Figures 13 and 14.

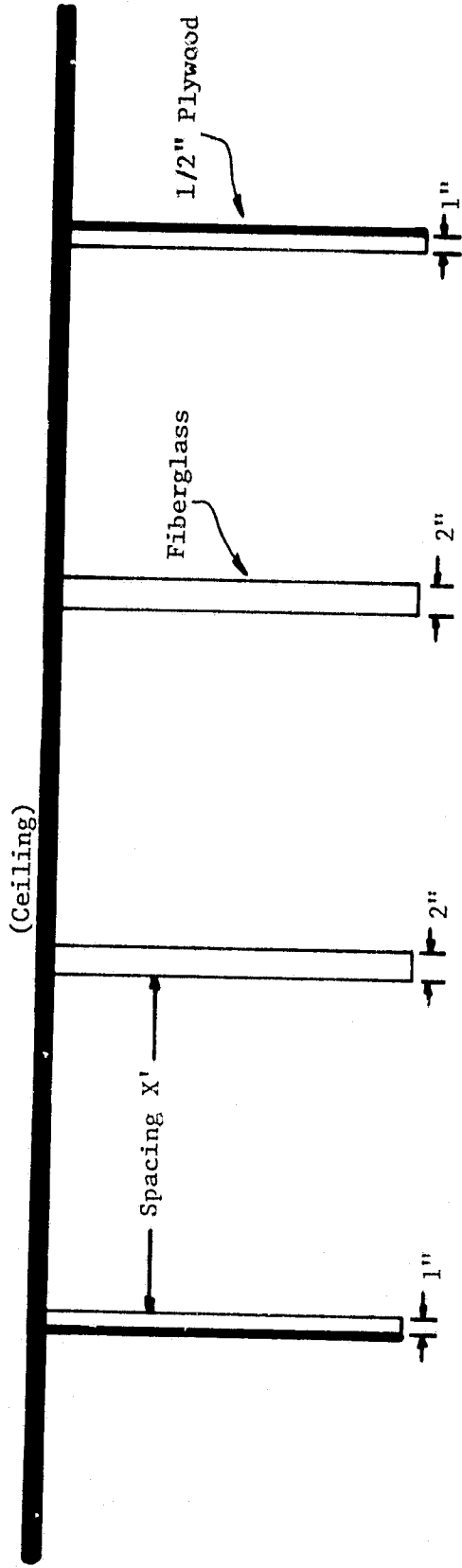

NOTE: Spacing Values X = 1/2, 1, 2, 3, 4

Figure 12 - Schematic of Panel Spacing Test

The test results from Table 11 demonstrate that the hanging arrangement had absorption characteristics similar to those of panels lying flat on the floor when spaced as shown in Figure 15. Since a 2' spacing arrangement utilizes the same amount of material per square foot of area covered as panels placed flat on the floor, less total absorbing medium was needed using the hanging arrangement to achieve results similar to placing panels flat against the ceiling.

The test results observed from Figures 13 and 14 demonstrate that as the spacing between panels is increased, the unit absorption per panel increases. The values in Figure 13 for the uncovered panels resemble results reported by Owens-Corning.¹⁰ As they noted, there is an optimal panel spacing beyond which no additional increase in unit panel performance will be achieved. This spacing, however, is frequency dependent. Figure 14 shows that the relationship between panel spacing and unit panel absorption is changed by the addition of a cover, particularly in the lower frequency octaves, where the increase in unit panel absorption bears an exponentially increasing rather than decreasing relationship with larger spacing. This suggests a possible shift in the optimal panel spacing point if covering materials are used.

NO COVER

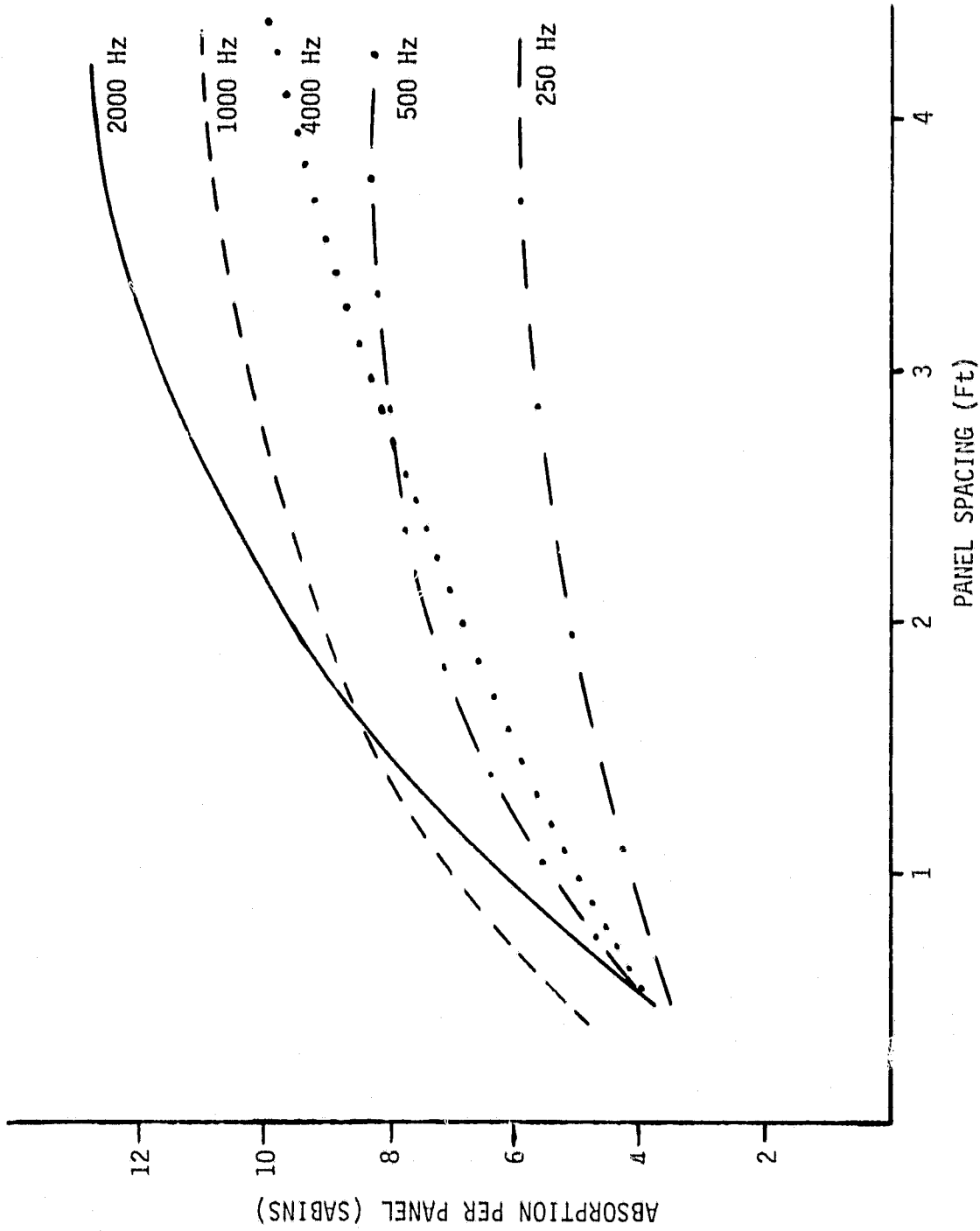

Figure 13 - Panel Absorption as a Function of Spacing (Uncovered Fiberglass)

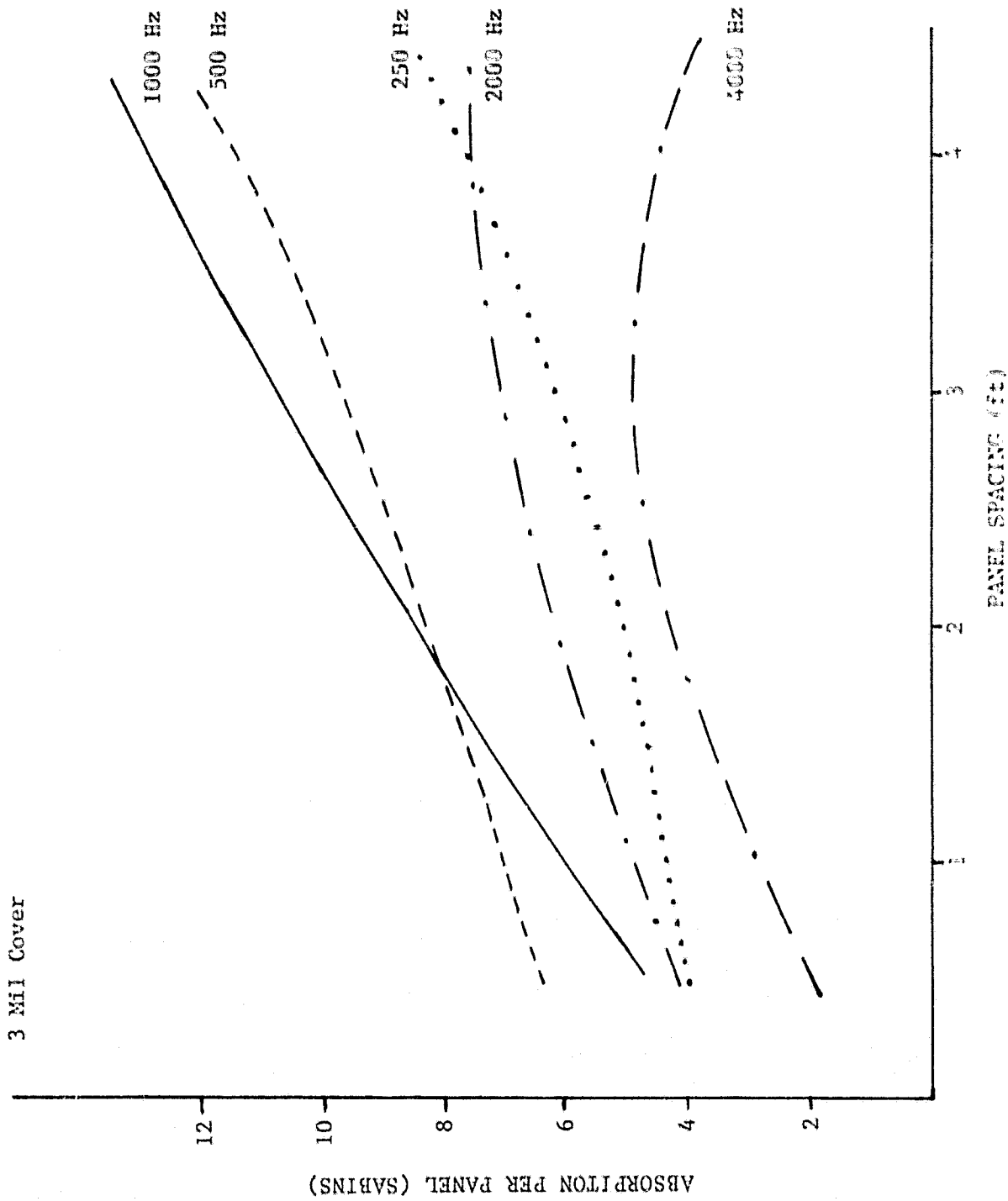

Figure 14 - Panel Absorption as a Function of Spacing (Fiber-glass covered with 3 mil Mylar)

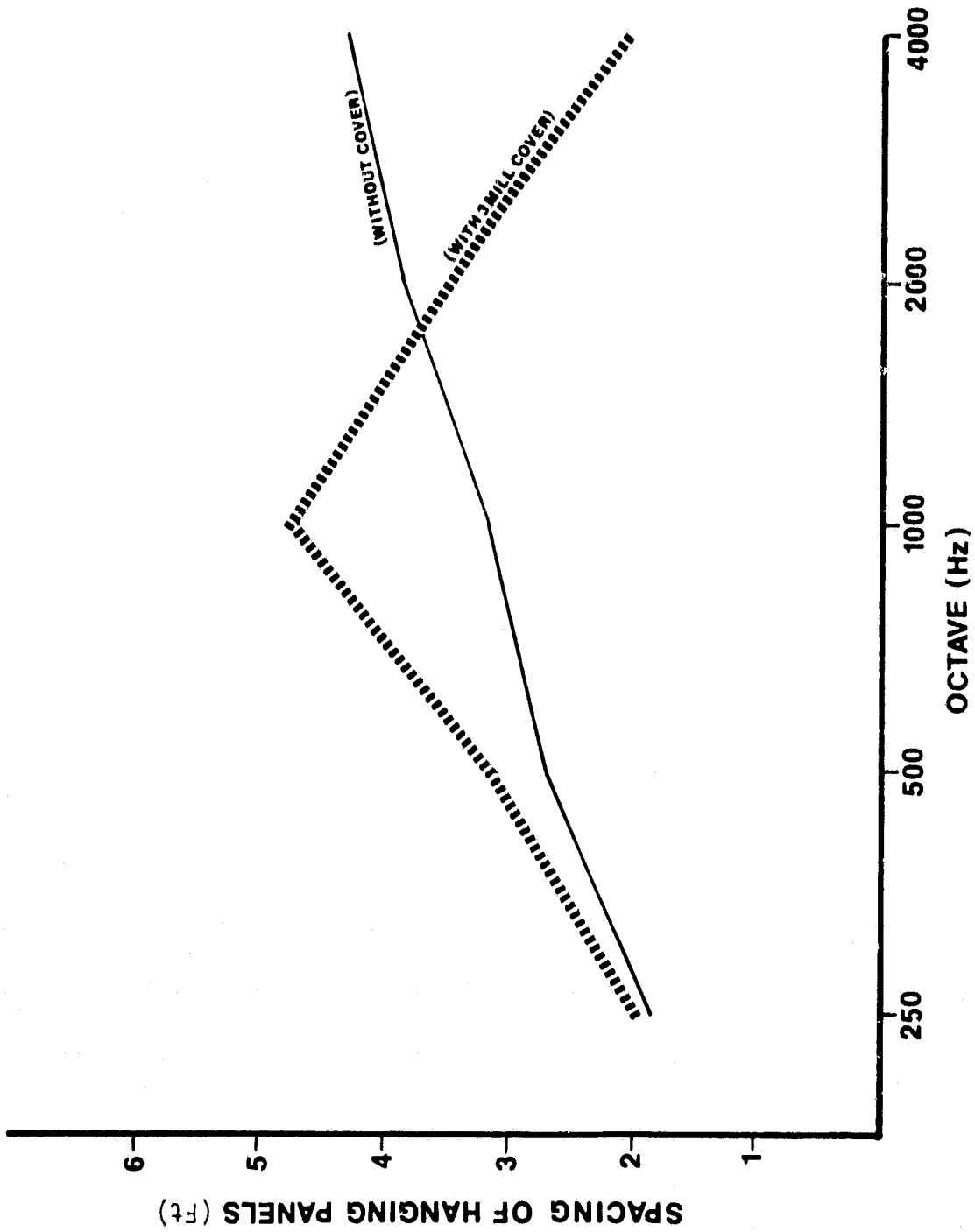

Figure 15 - Spacing at which Hanging Panels have Comparable Absorptive Qualities per Square Foot of Surface Area Covered as Panels placed Flat on Surface

Table 11

ABSORPTION COEFFICIENT OF A CEILING SURFACE COVERED
WITH HANGING PANELS

<u>Panel Spacing</u>	<u>250 Hz</u>	<u>500Hz</u>	<u>1000Hz</u>	<u>2000Hz</u>	<u>4000Hz</u>
Uncovered @ 6"	1.000*	1.000	2.000	1.000	1.000
Uncovered @ 1'	.988	1.000	1.000	1.000	1.000
Uncovered @ 2'	.671	.842	1.000	1.000	.919
Uncovered @ 3'	.502	.709	.862	1.000	.660
Uncovered @ 4'	.386	.444	.688	.741	.619
Covered @ 6"	1.000	1.000	1.000	1.000	1.000
Covered @ 1'	1.000	1.000	1.000	1.000	.723
Covered @ 2'	.622	1.000	1.000	.726	.614
Covered @ 3'	.488	.810	.914	.642	.437
Covered @ 4'	.509	.758	.802	.446	.250

* Note surface absorption values greater than 1 are listed as 1.

Utilizing the two pieces of information above, it becomes obvious that there are off-setting considerations which dictate the best panel spacing for a poultry processing plant. As the spacing between panels is decreased, higher absorption per square foot of ceiling area covered is achieved. However, the unit absorption of each panel utilized declines. The net result is a less efficient utilization of the absorbing properties of each panel. A plant may want to set target reductions in reverberant noise levels and select the corresponding panel orientation absorption values needed to achieve this reduction.

One additional study we performed involved placing panels flat against the ceiling between hanging panels spaced 3' apart (see Figure 16). Reviewing this orientation by absorption per square foot of ceiling area covered, we developed the values in Table 12. While the absorption values exceed those for the 3'

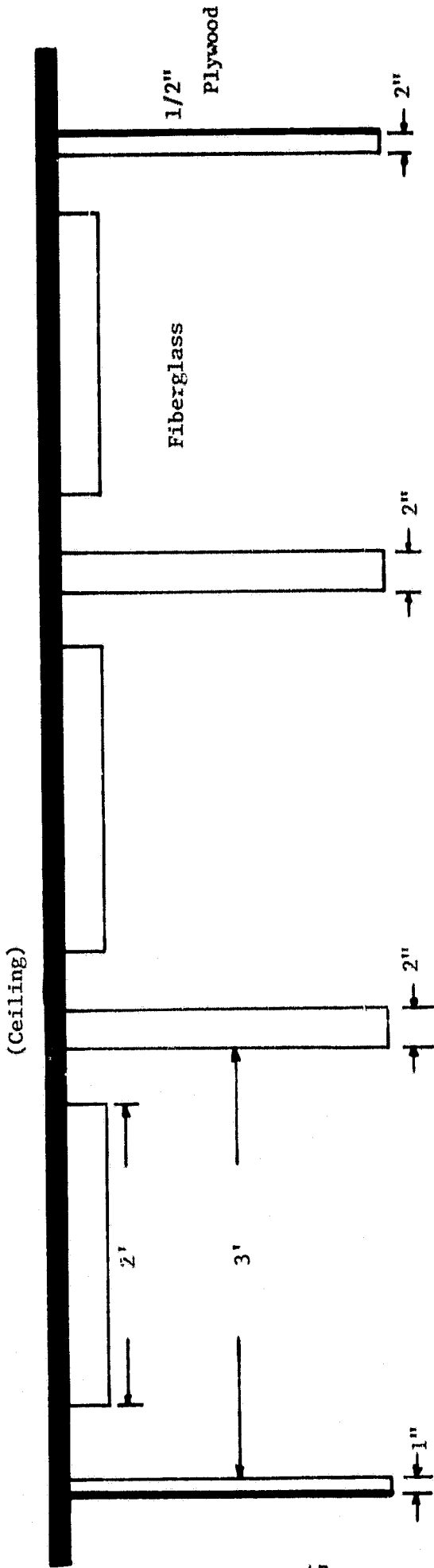

Figure 16 - Schematic of Panel Spacing Test with Ceiling Panels Added

spacing with no inserts, the additional panels result in the following unit panel absorption rates: 250 Hz (5.9 sabins/panel), 500 Hz (7.1 sabins/panel), 1000 Hz (6.2 sabins/panel), 2000 Hz (5.2 sabins/panel), 4000 Hz (3.5 sabins/panel). If the eight panels had all been hung in a 12' x 4' area, the resulting equidistant spacing between panels would have been 1 1/2'. Using Figure 13, the absorption characteristics of such an arrangement per panel would have been: 250 Hz (4.6 sabins/panel), 500 Hz (7.6 sabins/panel), 1000 Hz (6.8 sabins/panel), 2000 Hz (5.5 sabins/panel), 4000 Hz (3.3 sabins/panel). When the two orientations are compared, there does appear to be some benefit in the 250 Hz octave to placing a panel flat between the hanging orientation. However, the remaining octaves show no appreciable difference in unit panel absorption.

Table 12

ABSORPTION COEFFICIENT OF A CEILING SURFACE
COVERED WITH HANGING PANELS

<u>Panel Spacing</u>	<u>250 Hz</u>	<u>500 Hz</u>	<u>1000 Hz</u>	<u>2000 Hz</u>	<u>4000 Hz</u>
Covered 3' with panels placed flat in the space between	.990	1.000*	1.000	.862	.580

* Note surface absorption values greater than 1 are listed as 1.

FOCUS ON SOURCE QUIETING

Introduction

Unlike the previous discussion of sound absorbing panels, which has an almost universal application, techniques which quiet noise sources are only effective if they attack the noise generating mechanism and if that source is significant in terms of the overall noise field. As we discovered in our studies, the sources of noise can be many. For instance, a gearbox not properly greased or a drive shaft slightly warped can both produce excessive noise.

It became obvious in our study that proper maintenance was a key factor to holding individual machinery noise levels to a minimum. Yet it also became obvious that machine design often compounded the difficulty of minimizing machine noise levels. In particular, we found fault in the practice of bolting drive motors and pumps directly to large, expansive metal surfaces. This arrangement subsequently amplifies the total sound power emitted as a result of a failing or worn part. Also, there is an industrywide practice of leaving drive motors and pumps exposed rather than covered.

It is in the area of machine design modification and source isolation that we saw the possibility for a general approach to reducing noise levels. The discussions which follow focus on the major sources of noise identified in our previous report¹¹ along with a few additional sources which offered a potential for significantly contributing to the plant noise problem. This section summarizes our findings regarding source quieting in poultry processing plants.

Current Technology

The current state of the technology for source quieting in poultry processing plants consists primarily of source isolation. For instance, picking machine noise has long been a problem in terms of employee noise exposure in many plants. But it has effectively been dealt with by isolating the machines in a room of their own. Since the machines typically require little attention, only periodic employee exposure takes place.

Improvements made to machinery to enhance productivity, also have lowered noise emissions. For example, hand-held lung guns are being replaced with automatic drawing machines in broiler plants. These drawing machines use no vacuum, which is the source of noise in a lung gun operation.

These events point to the need for an overall awareness of the noise-generating mechanisms common to poultry processing machinery. Rather than to redesign a machine which may soon become obsolete, we chose in this study to evaluate what could be done to a machine, while still in place, to reduce its noise levels. By identifying the noise generating mechanism, we also hoped to make machine designers aware of points to consider in future designs to minimize noise output.

The Chiller

In order to understand the noise-generating mechanism of a chiller, we studied two units.

The first unit was a paddle-type chiller common throughout the industry (see Figure 17). We began the study by filling the chiller with water and

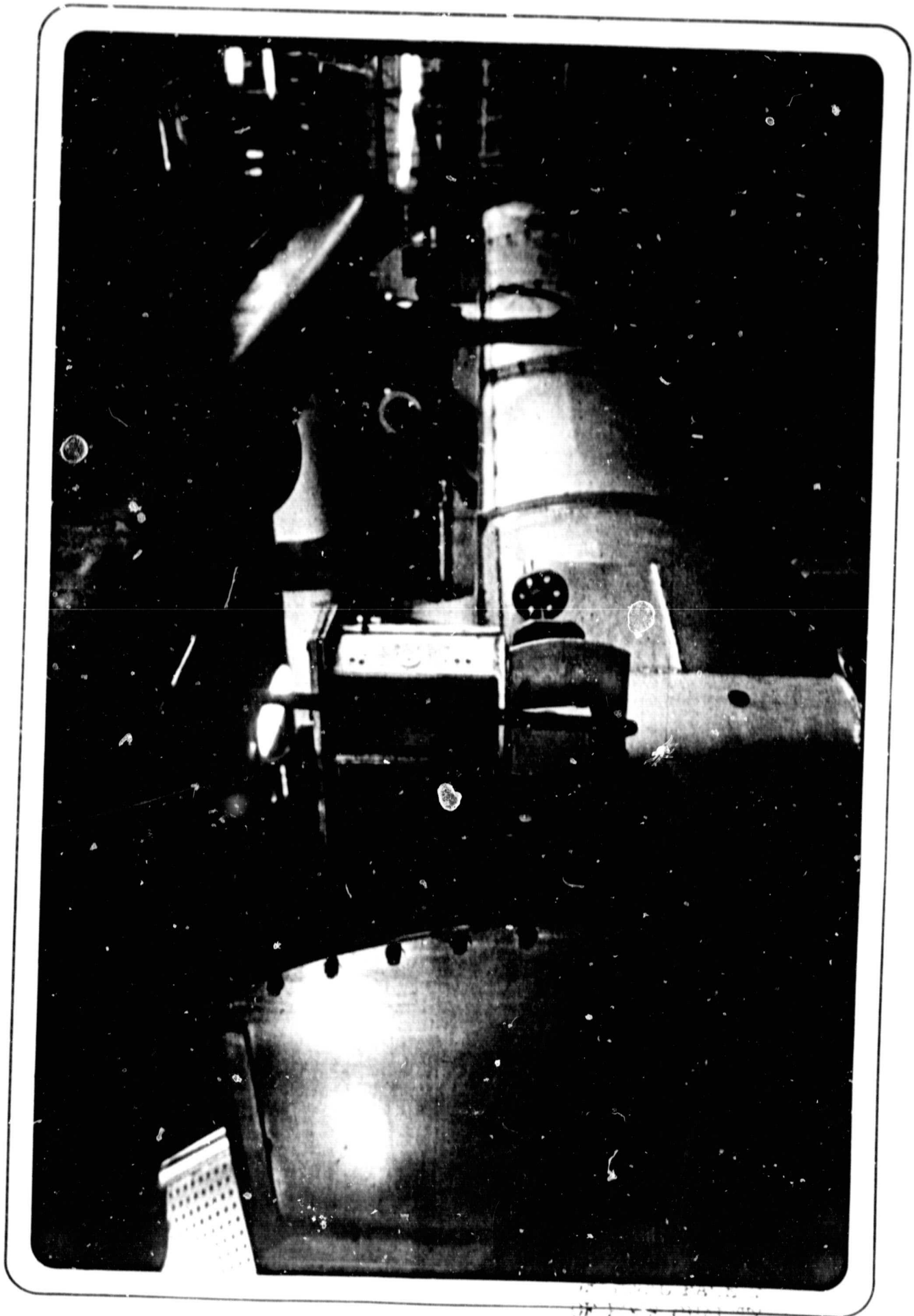

Figure 17 - Paddle Chiller

turning individual components on and off one at a time. The result was a characterization of the noise signature of each component (see Figure 18). When it became obvious that the pumps were the primary noise-generating mechanism for this chiller, we immediately began a detailed study of it.

We first took a series of noise readings on the chiller while varying general conditions. Our test scenario involved operating a single circulating pump on the chiller, first without any water in the chiller and then with water in the chiller. This helped to identify the role water plays in quieting chiller noise. Next, a hood filled with 3" fiberglass padding was placed over the top of the pump housing and drive motor (see Figure 19). This later feature allowed us to reduce noise emanating directly from the pump top and drive motor. Figure 20 shows the impact on the chiller's noise spectra when water was added. The overall level dropped 3.7 dB. Figure 21 shows the impact on the spectra when the hood was then added. The overall level dropped an additional 3.3 dB.

The information in Figures 20 and 21 point out that a tremendous amount of sound energy emanating from the chiller is low frequency (250-2000 Hz). When the drive motor and pump housing top are covered, a full 3.3 dBA reduction in sound pressure level is observed, yet the primary reduction brought about by the hood is centered in the 2000-6000 Hz range. A possible explanation for this occurrence is that the pump and drive motor are unquestionably the noise-generating mechanisms (nothing else mechanical is operating), yet the pump housing and main chiller body are amplifiers of the noise generated. Due to their size, they are more efficient in acoustically transmitting the low-frequency portion of the generated spectrum. Another possible explanation

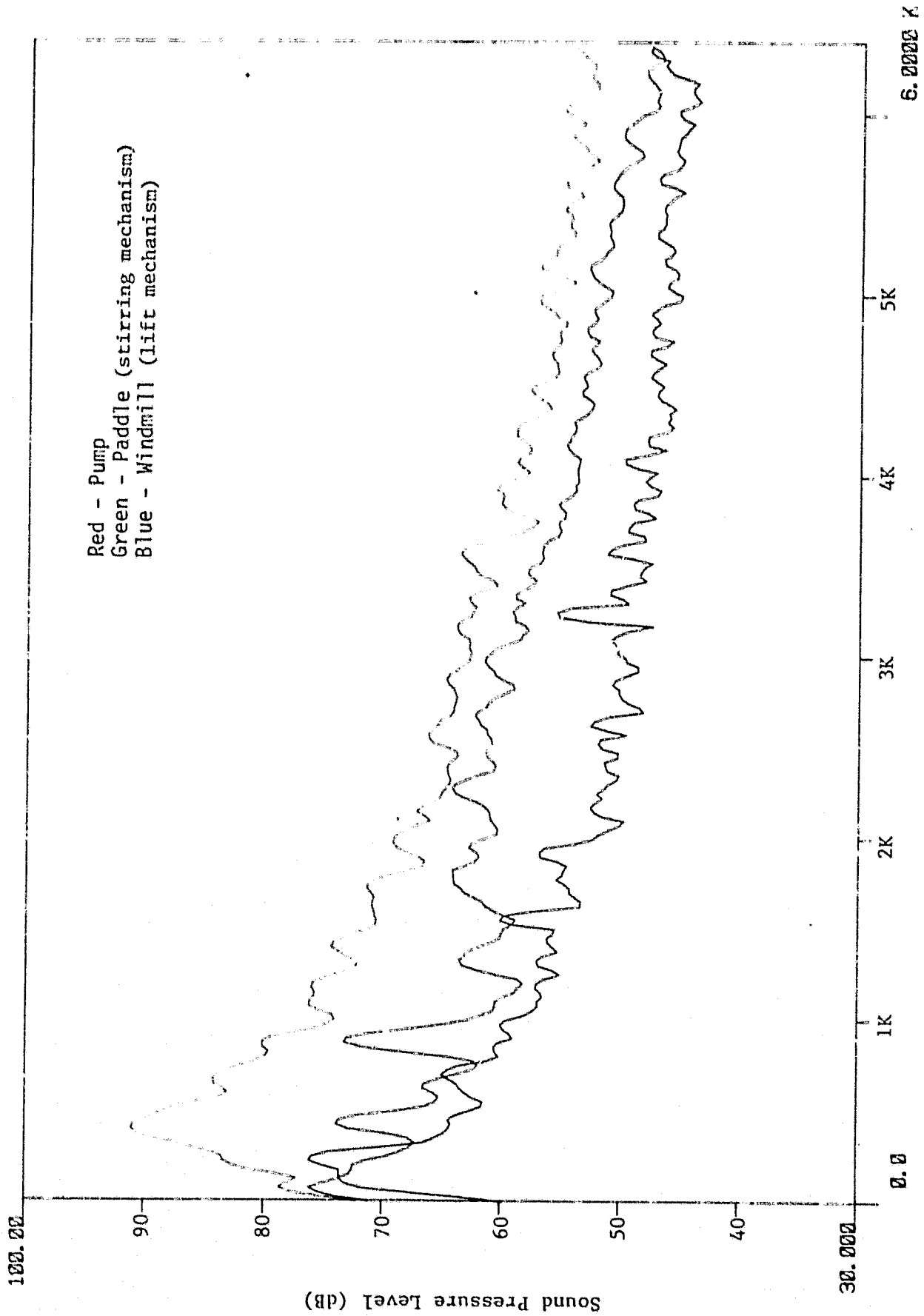

Figure 18 - Spectrum for Individual Components on a Paddle Chiller



Figure 19 - Hood Mounted over Pump Housing and Drive Motor

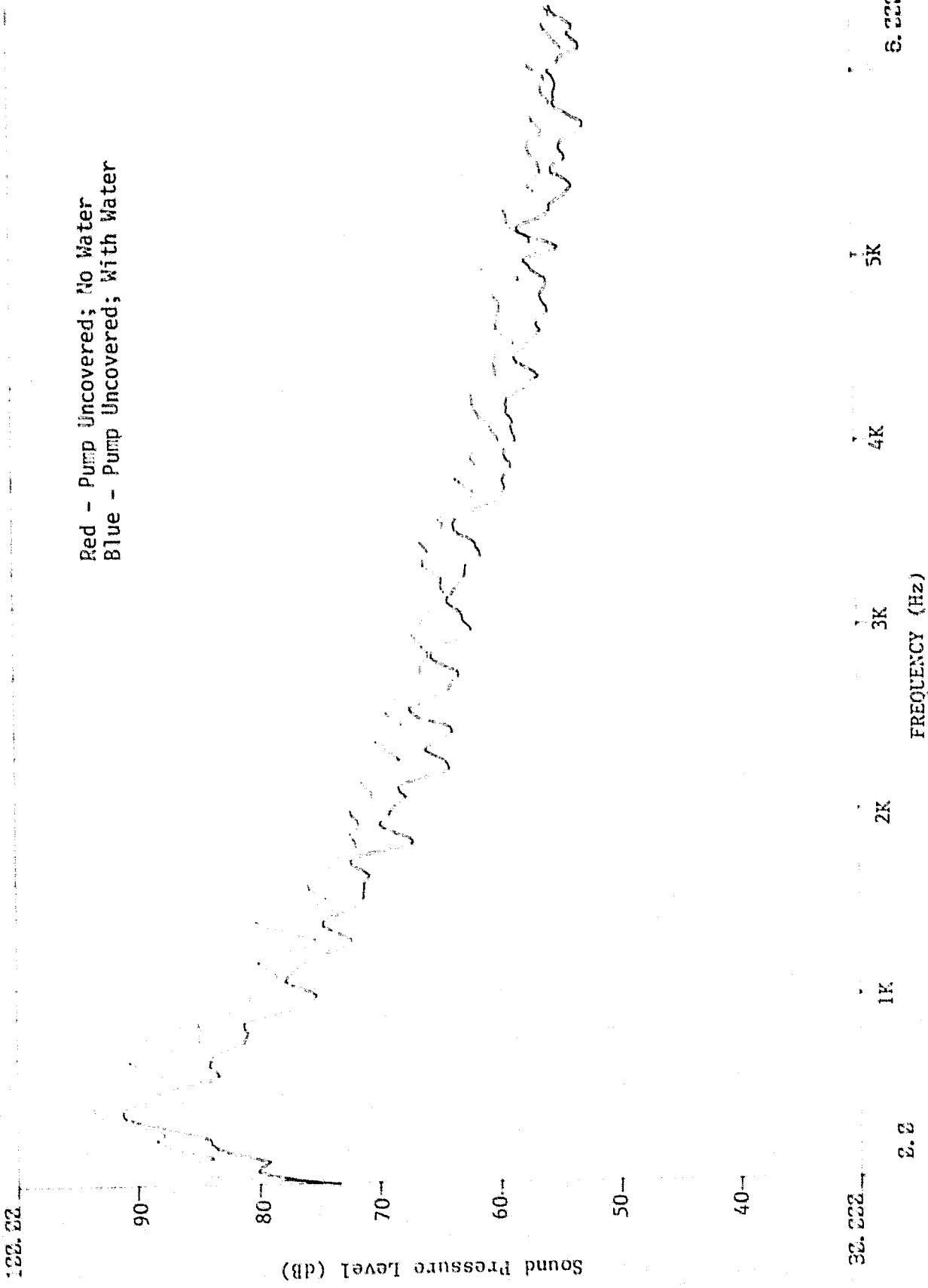

Figure 20 - Sound Energy Spectrum Changes in the Paddle Chiller

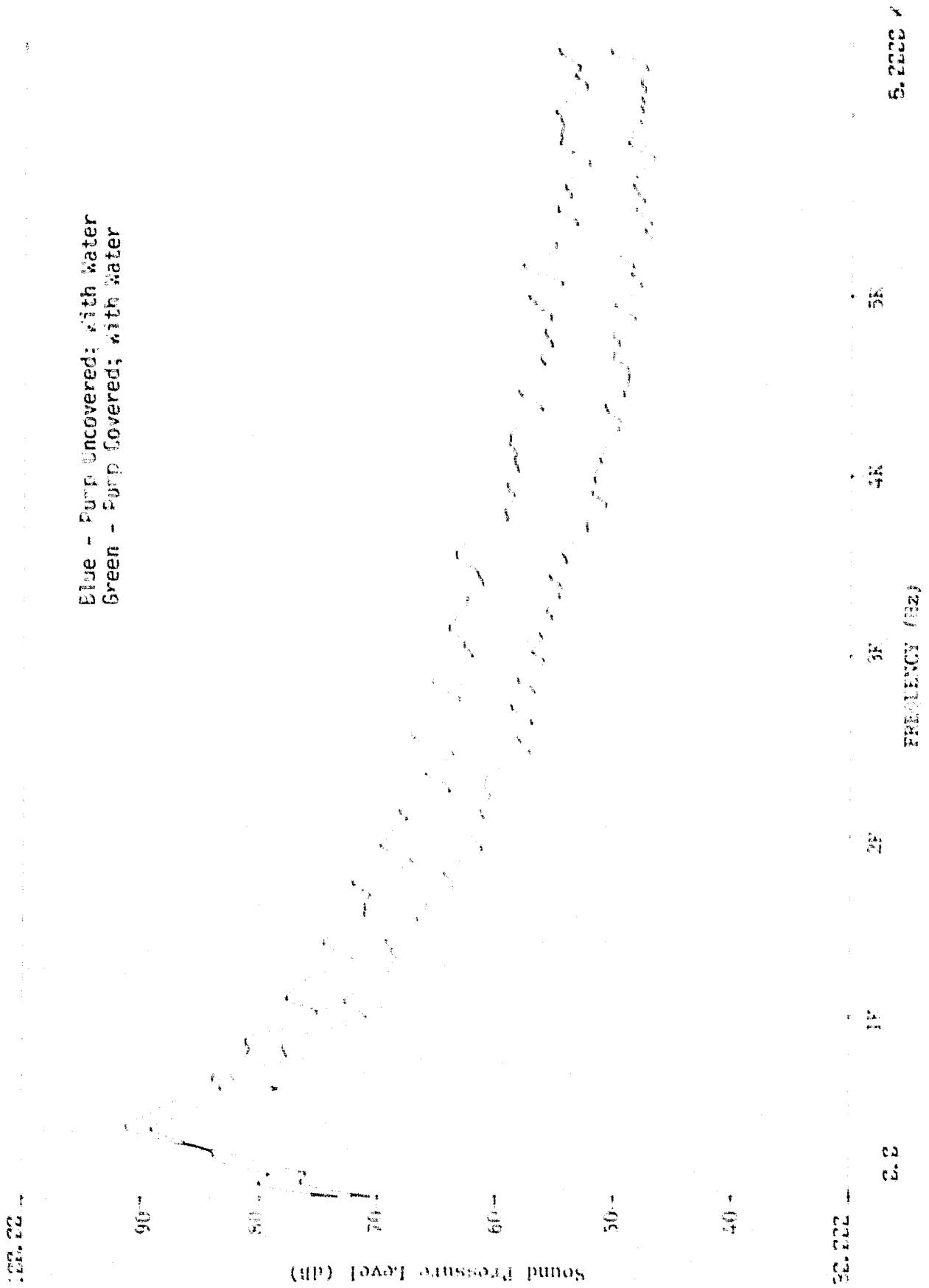

Figure 21 - Sound Energy Spectrum Changes in the Paddle Chiller

is that the acoustic hood was not effective in reducing low-frequency noise and that the pump was the only major noise-generating mechanism.

Using accelerometers and the equipment orientation shown in Figure 22, we attempted to perform coherence and cross correlation analysis to determine the noise signature of various parts of the chiller. Unfortunately, the accelerometer signals contained strong periodicity which prevented our using these techniques properly.

Our conclusion on chiller quieting, therefore, was inconclusive. We do believe that bolting pumps and drive motors directly to a chiller body allows the chiller body to amplify vibrations resulting from their operation, and the sound power transmitted from a chiller potentially can be held in check or possibly reduced by isolating the drives and pumps from the body. This alone, however, may not eliminate the problem, since the drive motors and pumps, by themselves, could be the major noise-generating mechanism. Consequently, where possible, drive motors and pumps also should be enclosed in a sound-absorbing hood.

As mentioned earlier, we studied two chillers. The second chiller was a gilet chiller (see Figure 23). During the course of our study, we discovered a problem in the gear box, and the gear box and drive motor were subsequently replaced. Figure 24 shows the change in sound energy transmitted by the chiller when the replacement was made. Overall, a 16 dB drop in sound pressure level was observed. Clearly this dramatizes the need to isolate and enclose the drive mechanisms. It also points out the need for good maintenance programs.

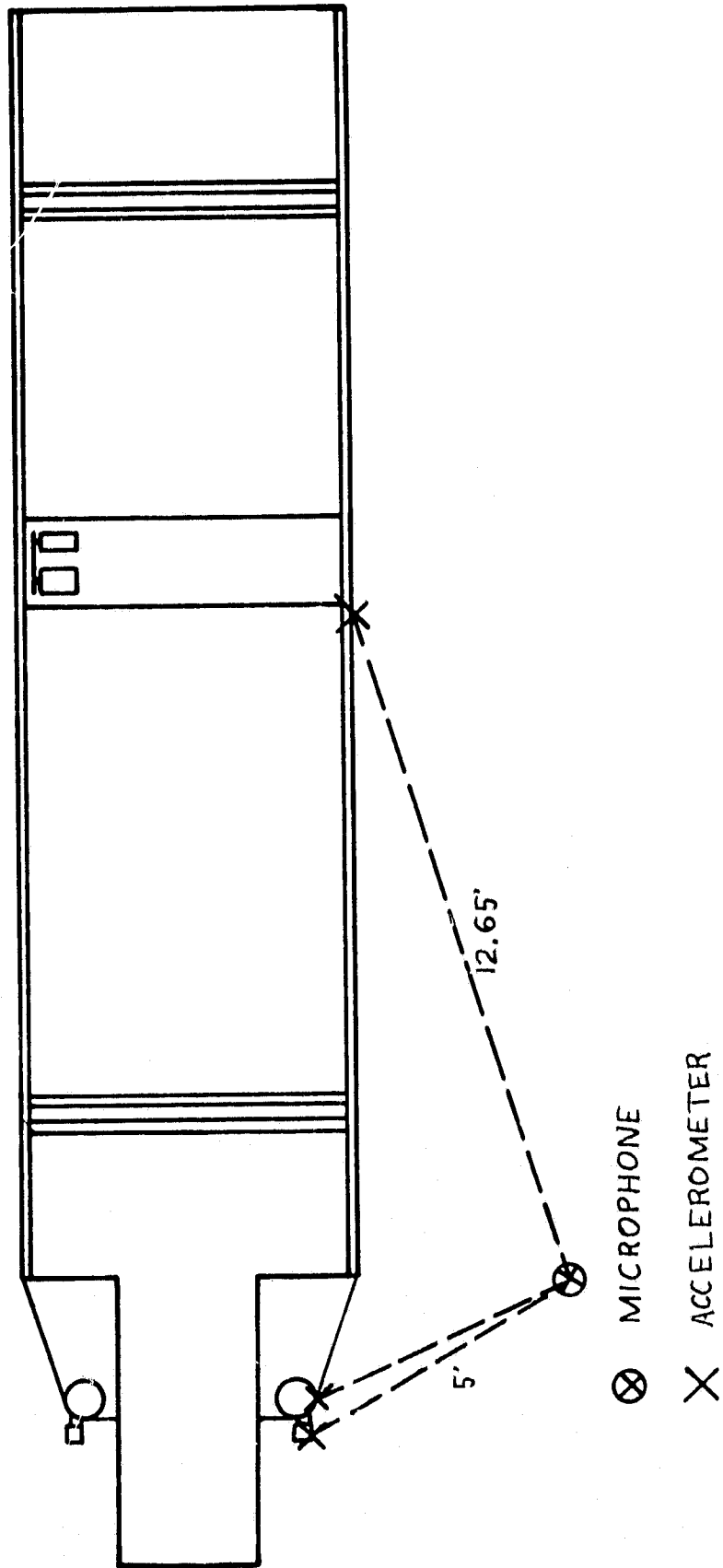

Figure 22 - Accelerometer and Microphone Locations for Chiller Analysis

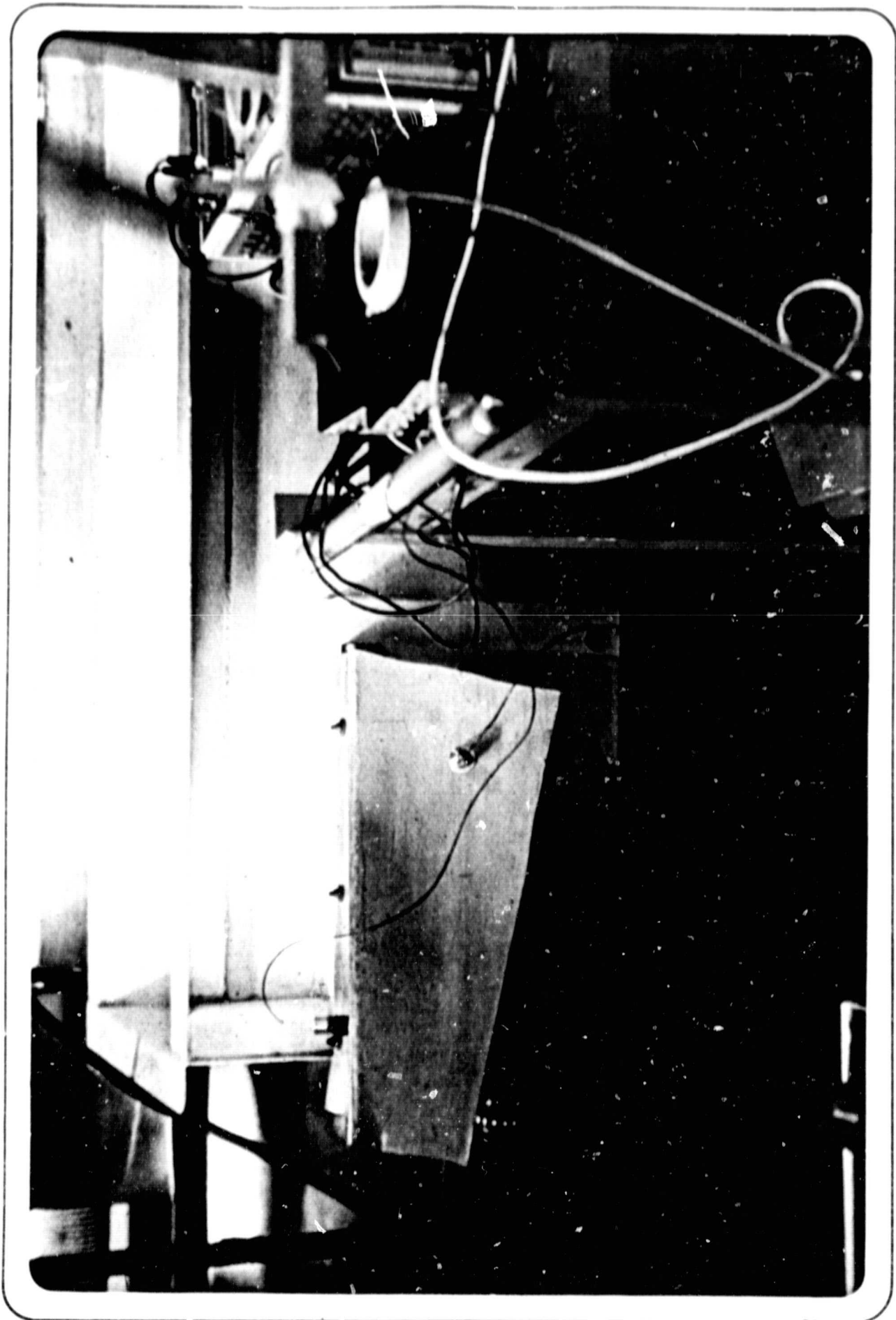

Figure 23 - Giblet Chiller Undergoing Tests

#A 30 EXPAND

A SPEC 2
100.00

Red - Before Gearbox Replacement
Blue - After Gearbox Replacement
Green - Ambient

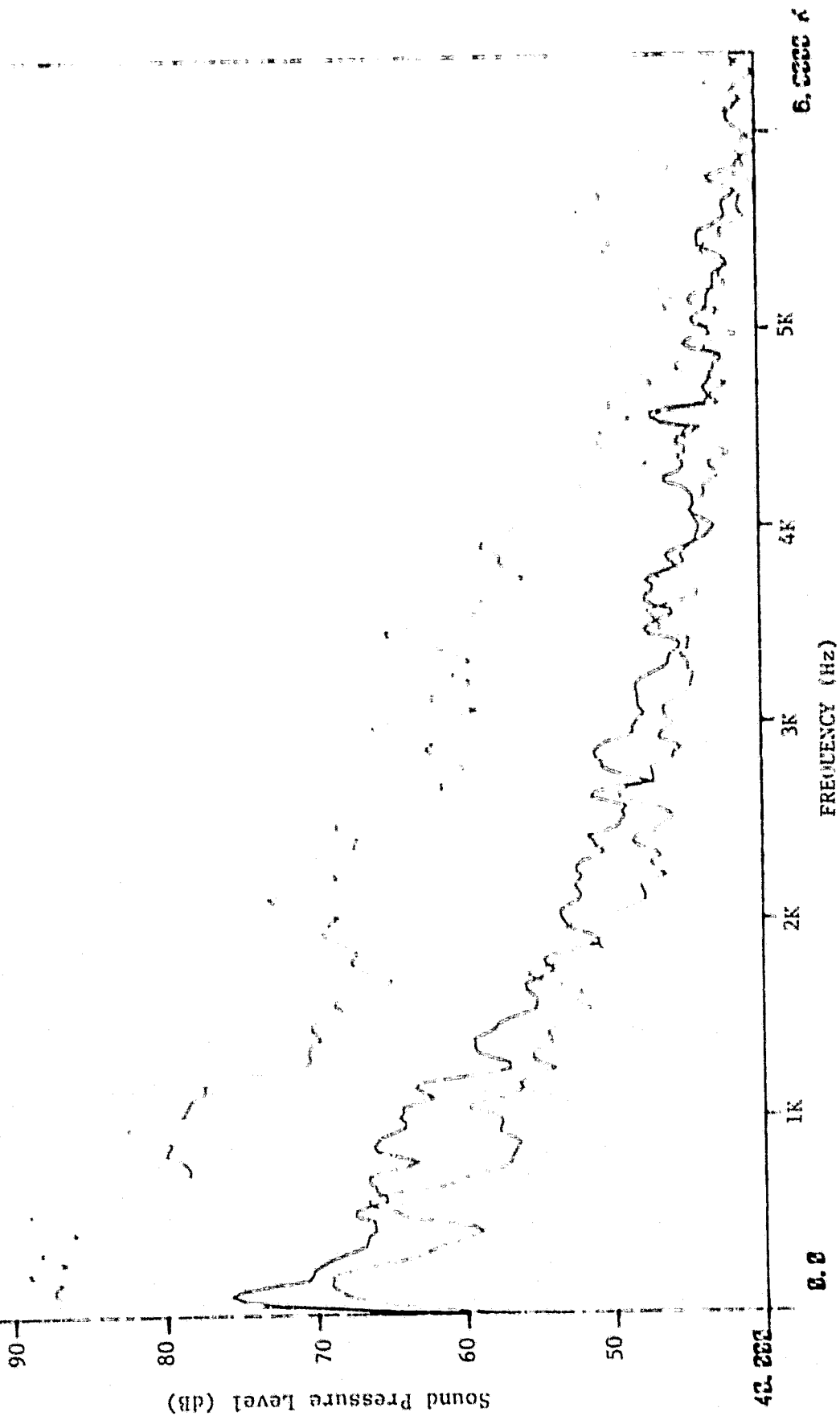

Figure 24 - Sound Pressure Spectrum Changes In The Giber Chiller

The Lung Gun

Lung gun noise is currently being alleviated by many firms who are replacing them with drawing machines that also pull out lungs. Unfortunately, not all plants can use drawing machines, either because of financial constraints or because they process birds of varying size which cannot be processed with existing drawing devices. In a plant where lung guns were replaced by drawing machines, a dramatic reduction in noise level was observed (see Figures 25 and 26).

Lung gun noise is caused by suction pressure between the surface being cleaned and the gun nozzle. Because this operation takes place in a cavity, resonances are set up which amplify the noise level.¹² Typically, several lung guns are operated within close proximity to one another, compounding the problem (see Figure 27).

In dealing directly with the source, we are aware of at least one research effort¹³ which culminated in a hood (see Figure 28) on the lung gun to block the opening to the cavity. While the design lowered noise levels 12 dB, it proved impractical in actual operation because operators complained of obstructed visibility in performing the lung removal.

One method that has worked is to reduce the vacuum on the gun to a level just necessary to perform the pulling function properly. Discussions with one plant indicated that by reducing excessive suction, they lowered sound pressure levels nearly 10 dB at the lung gun stations.

Another method that can work in dealing with lung gun noise is to place plastic barriers between each lung gun station. Since each lung gun is a

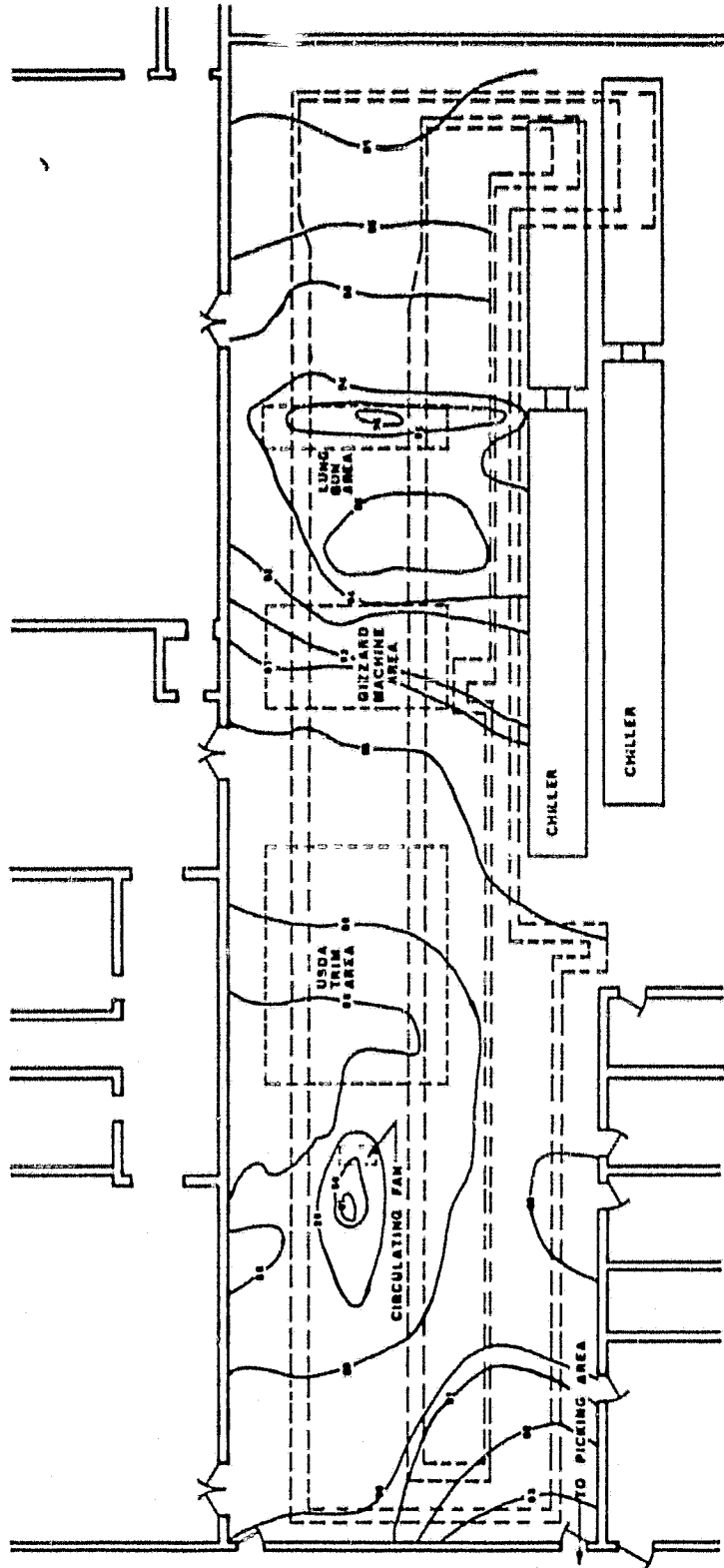

Figure 25 - Noise Contour in Plant with Lung Guns

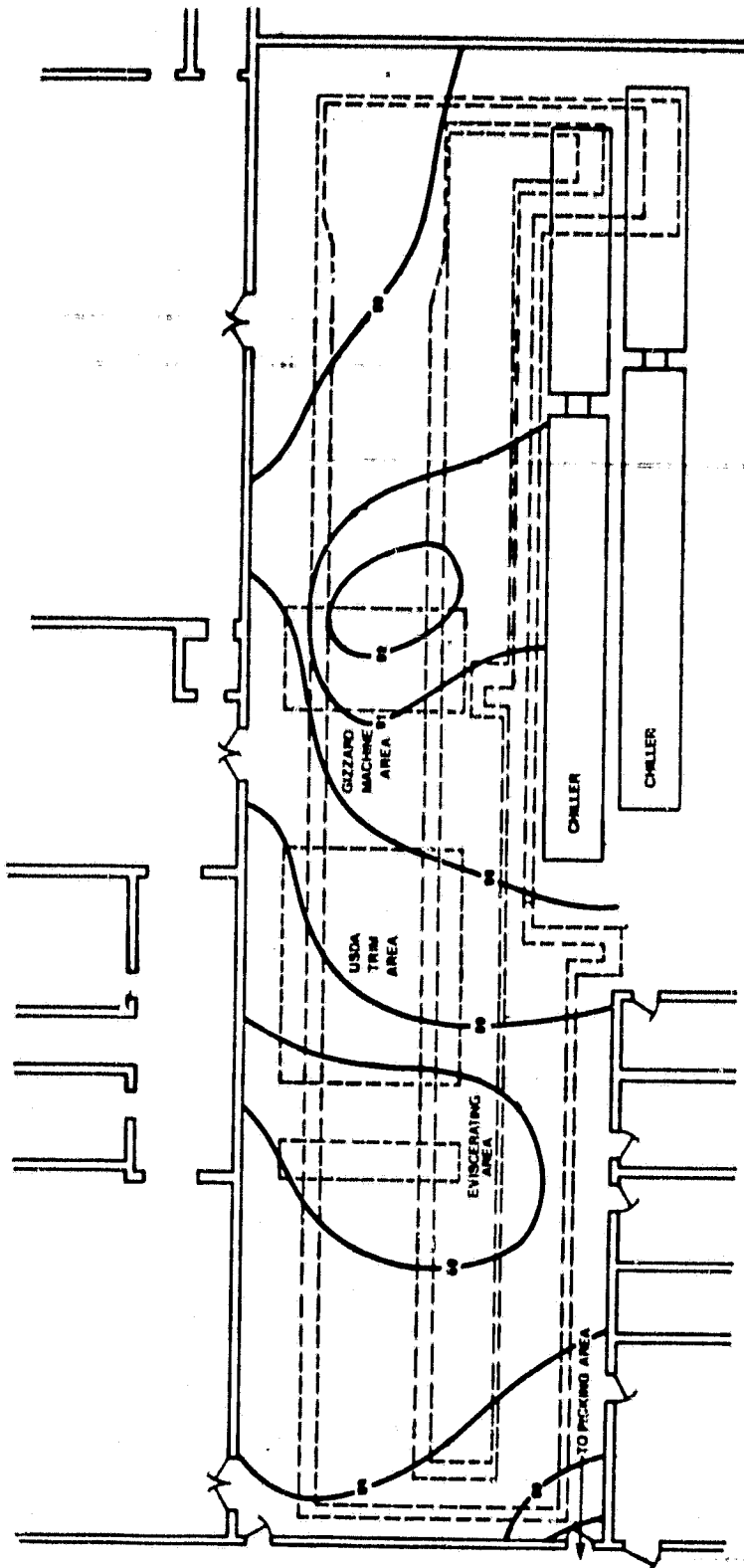

Figure 26 - Noise Contour in Plant with Lung Guns Replaced with Drawing Machines

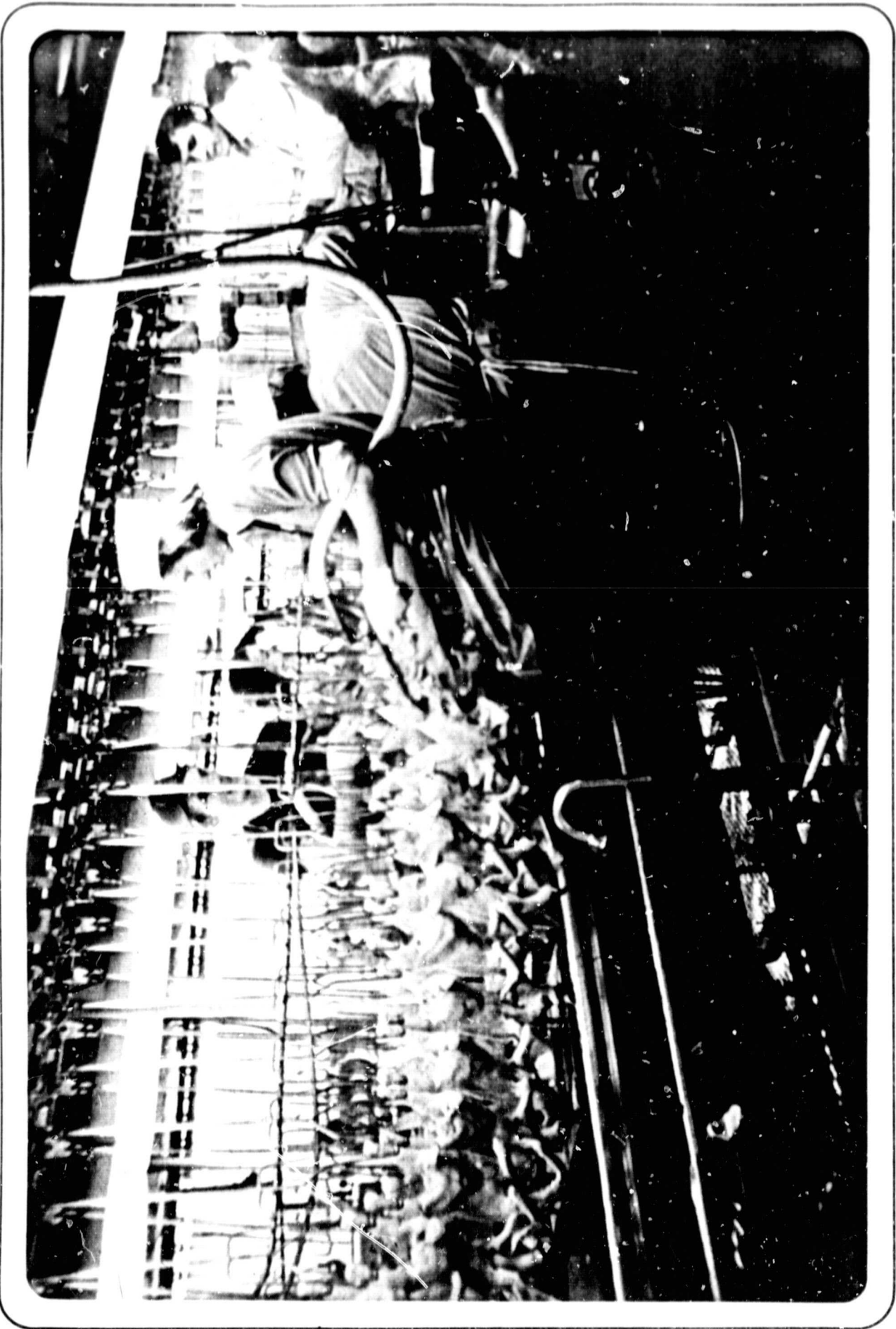

Figure 27 - Typical Lung Removal Area with Hand Held Lung Guns

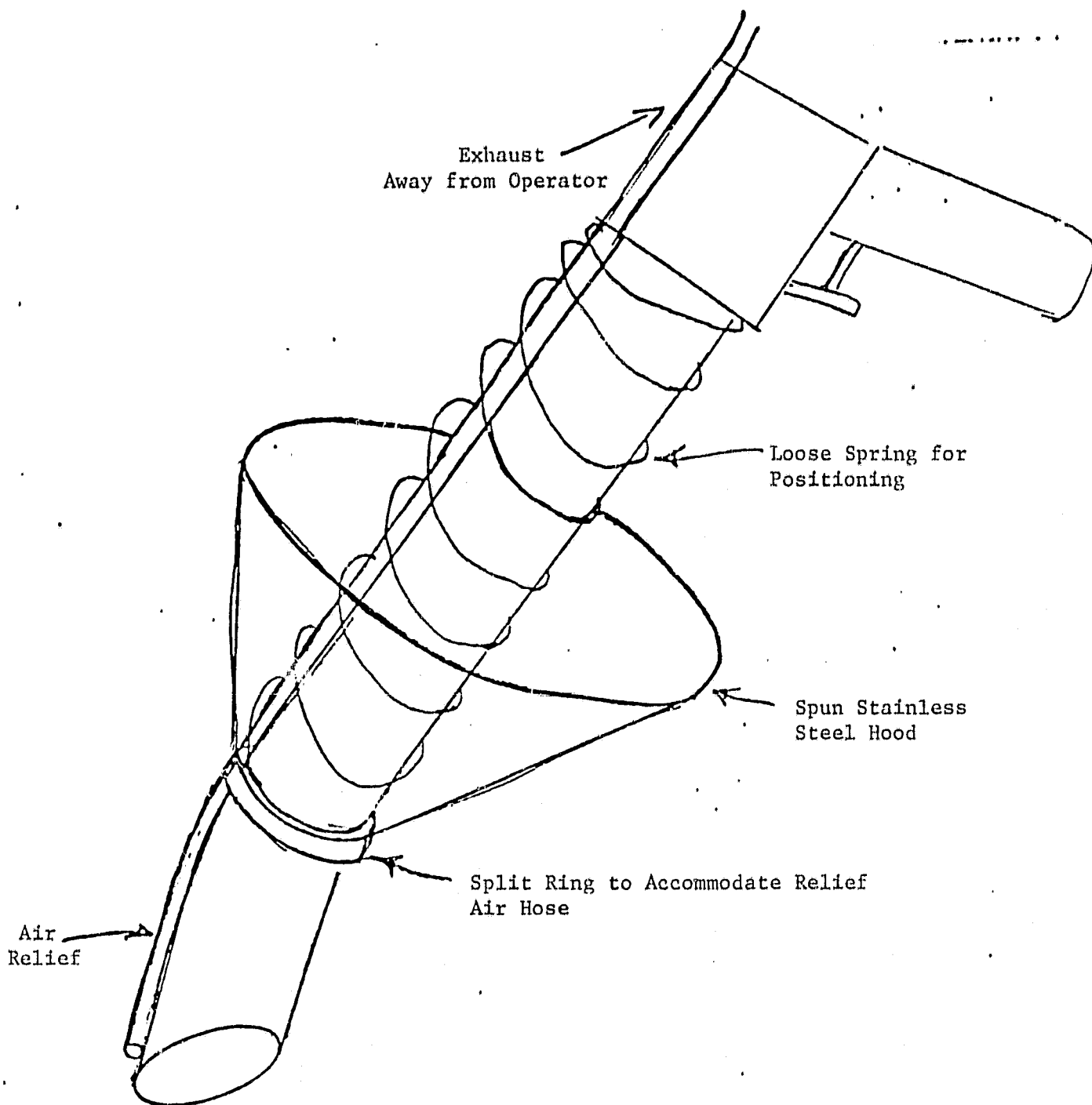

Figure 28 - Lung Gun Hood

single source, isolating the sources can have a tremendous impact on local sound pressure level readings both at and near the lung removal stations. One experiment showed as much as a 14 dB reduction in sound level at the station adjacent to the lung removal operation when a barrier was used.¹⁴ There are, however, problems with putting up barriers, problems which are primarily related to employee morale. In one plant which experimented with vinyl curtains, lung operators systematically cut the curtains down, apparently because they did not like being isolated from fellow employees. This problem perhaps can be overcome by using partial barriers which block the path of direct sound but still allow face to face contact between employees. We further recommend that an absorptive hood be placed directly above the work station, when barriers are used, to prevent sound pressure level buildup at the station.

The Hock Cutter

Hock cutter noise reduction has been accomplished largely by isolating the machine from personnel. Figures 29 and 30 display the observed noise reduction brought about by relocating the hock cutter to another area of the plant. However, isolation techniques are not always successful, either because a large opening is used to convey the birds back into the evisceration room or because many plants still require personnel to work near the machine after isolating it.

A review of the basic design of the hock cutter yields only a few possible explanations for the appreciable noise levels generated by this device. The typical hock cutter has a drive mechanism clustered to one side of the machine which is completely exposed except for a sheet metal safety

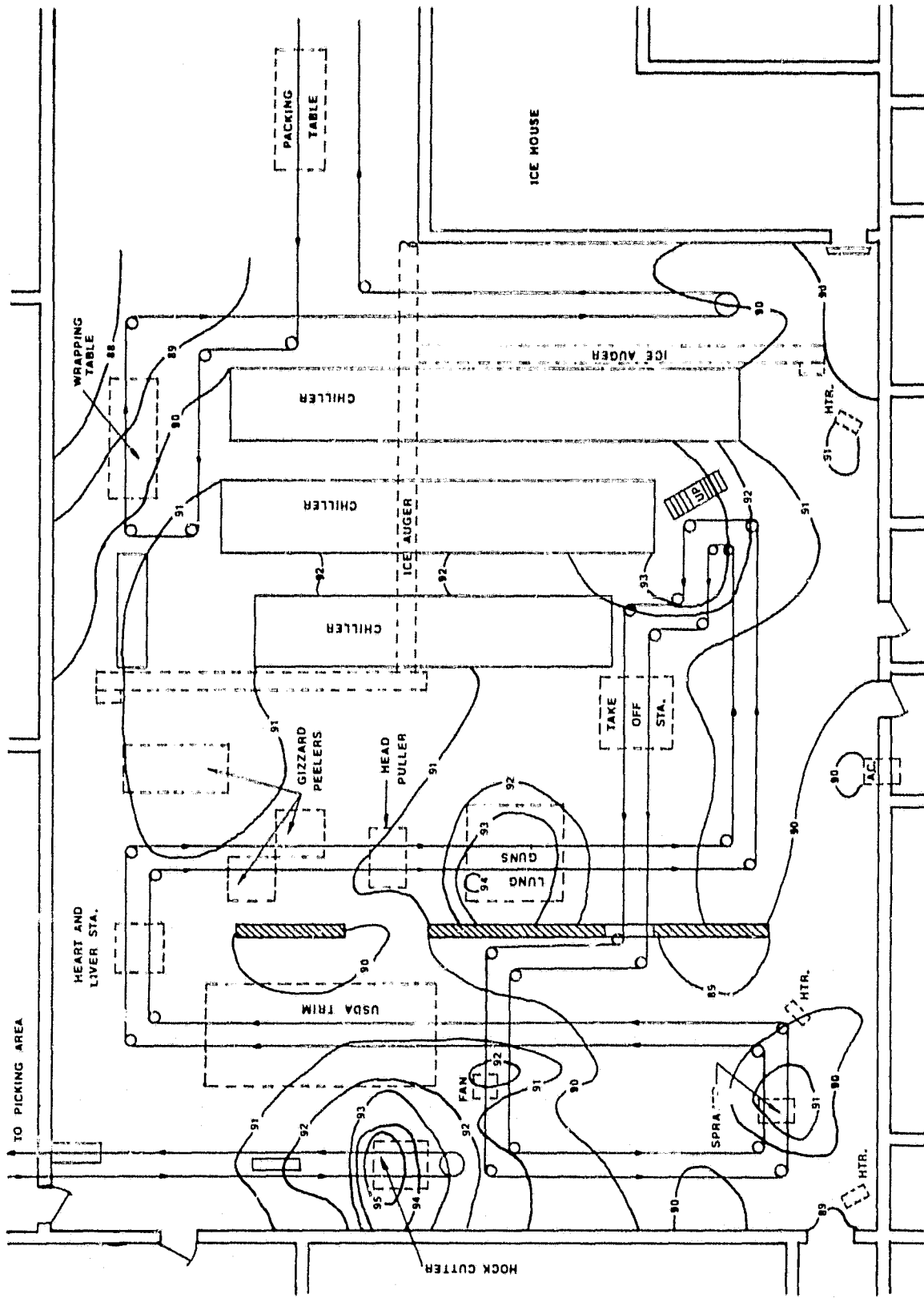

Figure 29 - Noise Contour in Plant with Hock Cutter

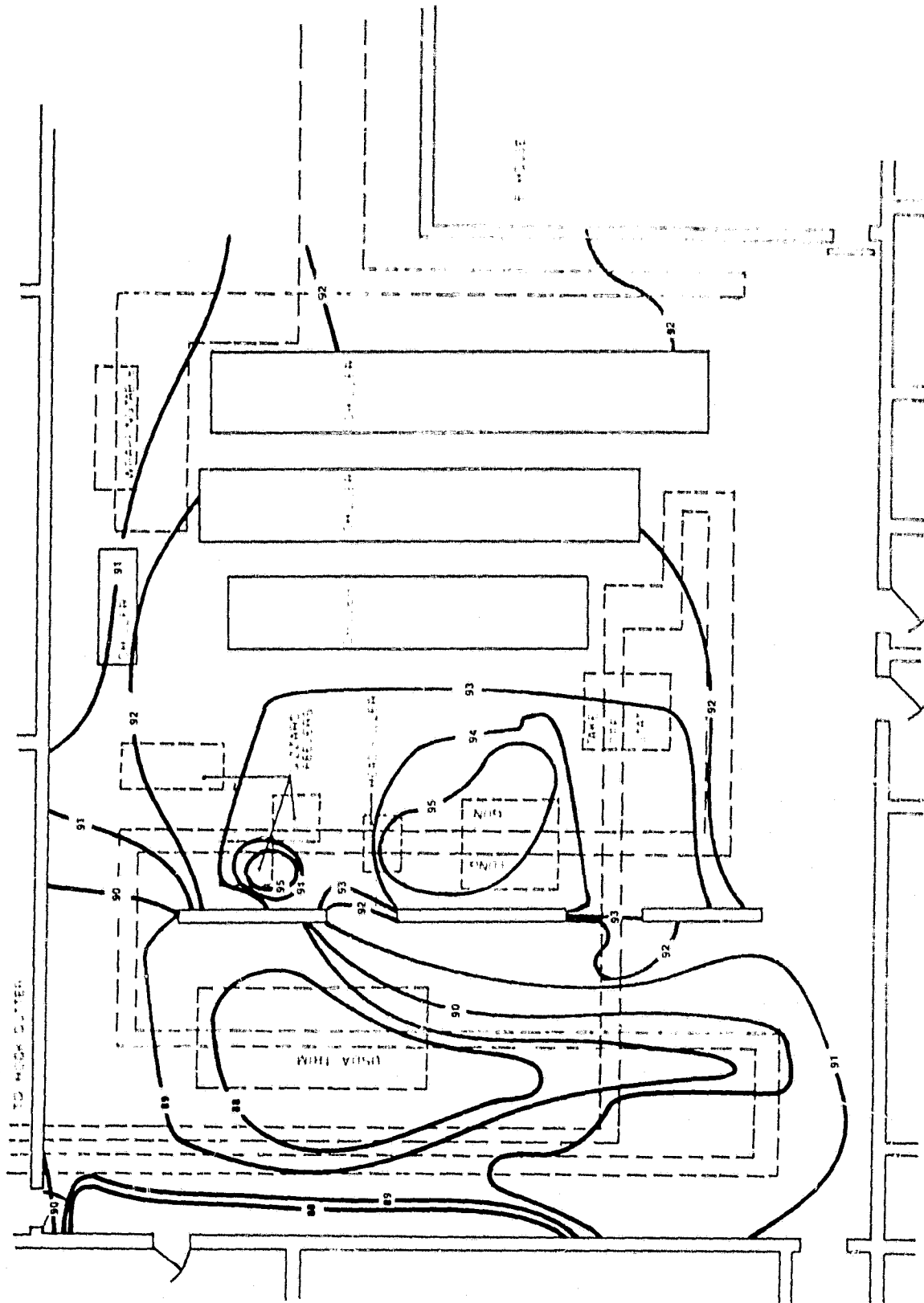

Figure 30 - Noise Contour in Plant with Hock
Cutter Removed

cover plate. These drive motors and drive belts all offer the potential for producing high noise levels.

As a means of attempting to quantify the contribution of the drive motors in generating noise, we mounted accelerometers first on one of the drive motors and then on the frame of a hock cutter and observed the relationship between these transducers and a microphone positioned five feet away (see Figure 31). Again we were unable to utilize coherence or correlation analysis techniques because the accelerometer signals were very periodic.

Therefore, we attempted to quiet the noise source with an enclosure packed with sound-absorbing material. Using a partial housing constructed of plywood and fiberglass (see Figure 32), we enclosed the drive area of the hock cutter. Nearly a 4 dB drop in sound pressure level was observed at the microphone position (see Figure 31). Figure 33 displays the change in the sound pressure spectrum observed during this series of tests.

The Vent Cutter

Vent cutter noise can contribute significantly to local noise levels in a plant. A vent cutter in many cases is merely a pneumatic drill used to open the bird for subsequent evisceration. While newer machine designs exist whereby the drilling is performed automatically by mechanical drive mechanisms, for the pneumatic tools that continue to be used, we evaluated the potential effectiveness of exhaust mufflers. The muffler we selected was a polyethylene design (see Figure 34) which was washable and rugged.

Figure 35 shows the change in sound spectra, measured one foot away from the exhaust part, both before and after muffler attachment. A noise reduction

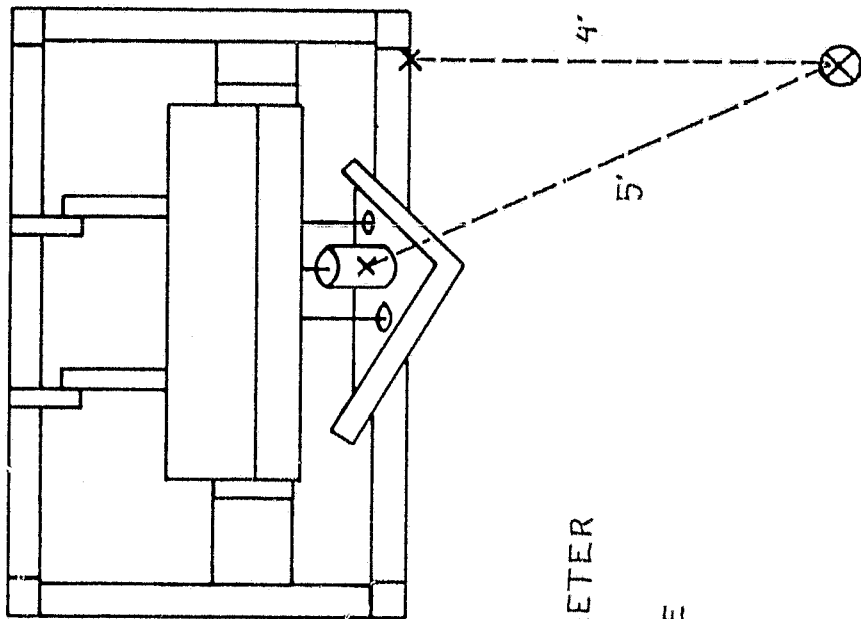

X ACCELEROMETER

⊗ MICROPHONE

Figure 31 - Accelerometer and Microphone Locations
For Hock Cutter Analysis

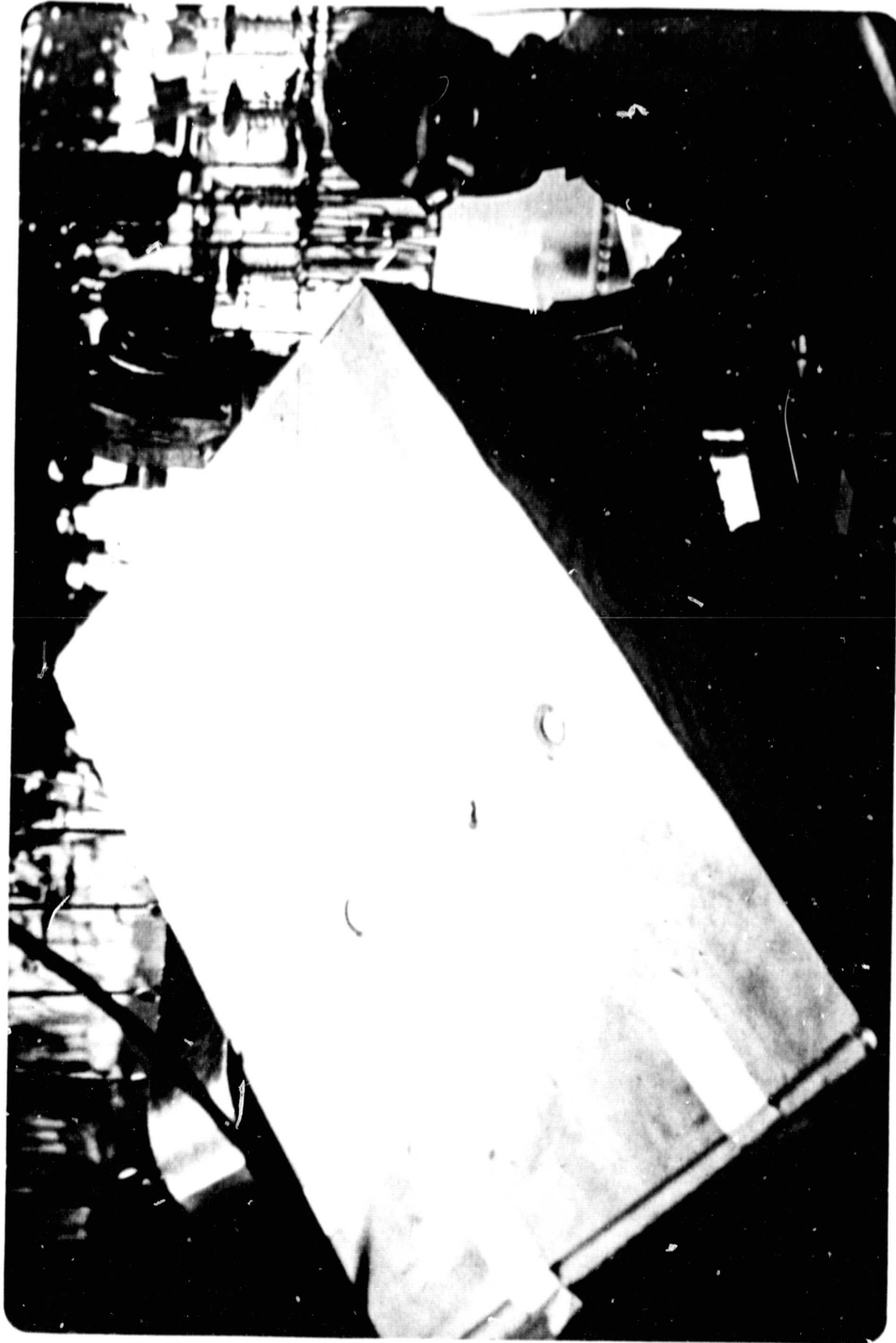

Figure 32 - Partial Housing Placed Over Hock Cutter
Drive Motors

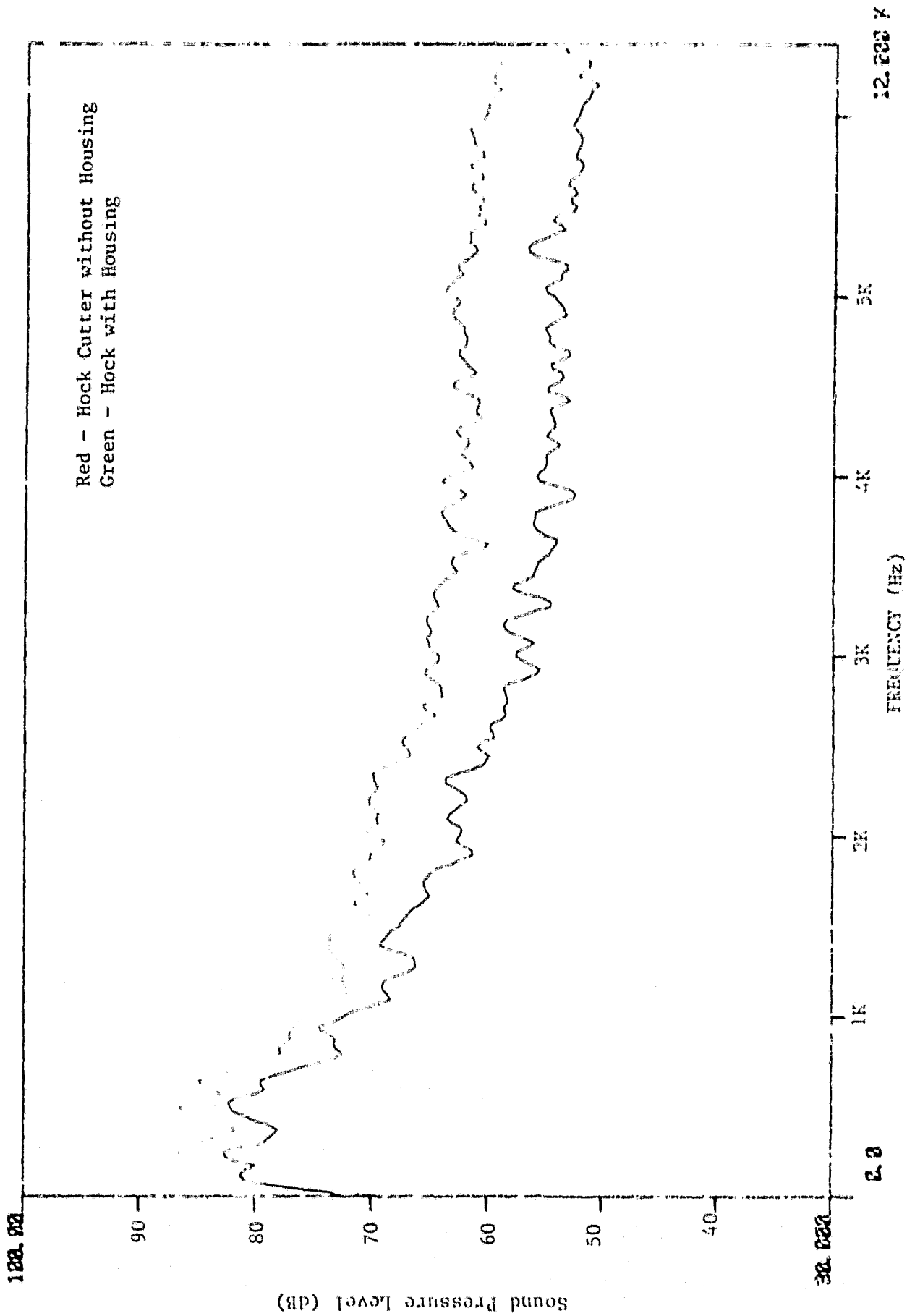

Figure 35 - Sound Energy Spectrum Changes in the Hock Cutter



Figure 34 - Pneumatic Muffler Tested

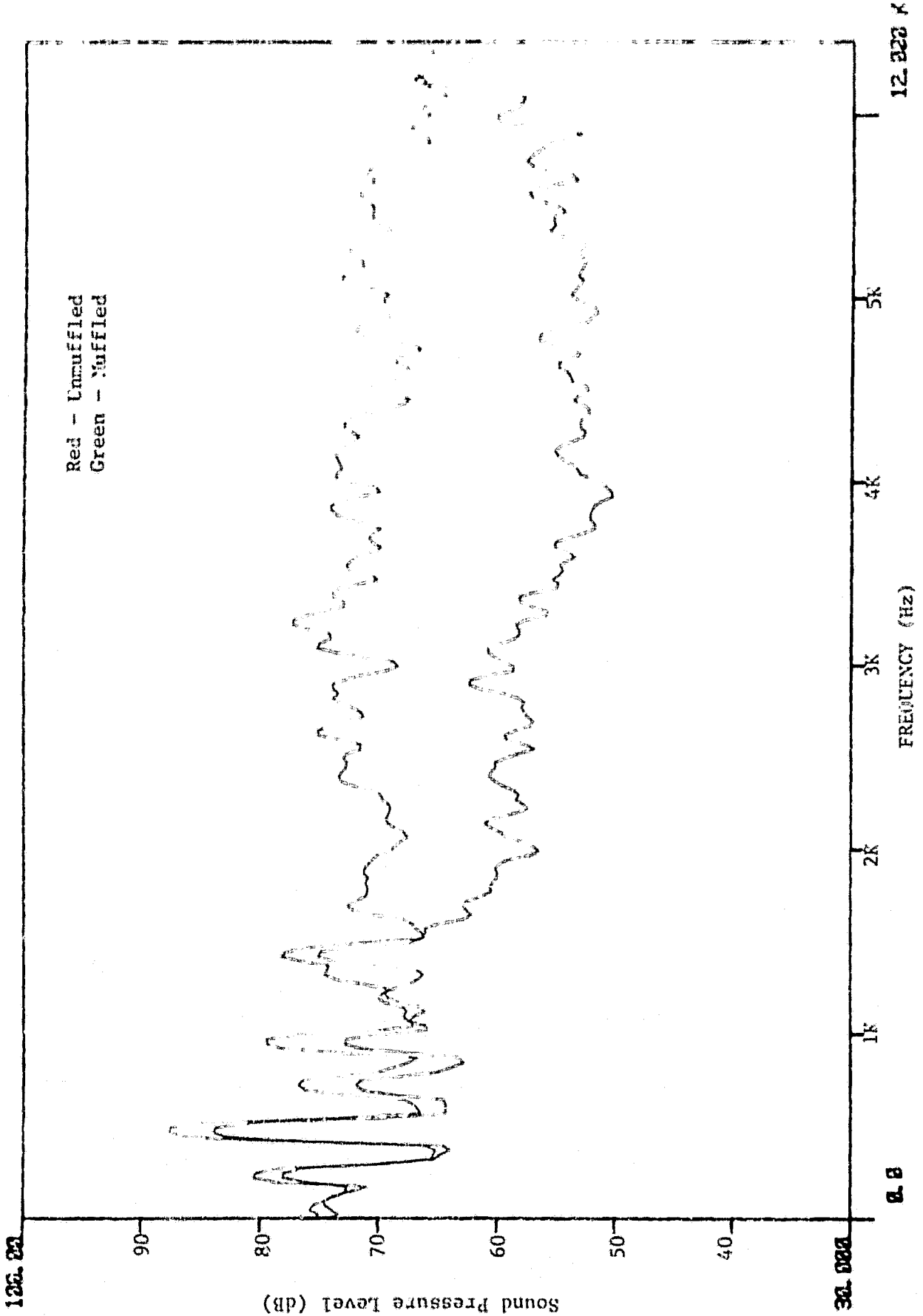

Figure 35 - Sound Energy Spectrum Changes in the Vent Cutter

of 5 dB was observed.

Perhaps the only potential problem with utilizing these muffling devices is their potential for plugging if the air supply is not properly filtered. However, if the air supply filter is working properly, then the muffler we tested should offer little obstruction to normal tool operation. An arrangement is possible, using exhaust hoses on each tool connected to a central overhead exhaust header, to minimize the potential for plugging on air systems with marginal filtration efficiency.

Ice System

Ice troughs and dump stations are another potential noise problem area. While they do not always emit high levels of broadband noise, discrete frequency discharges can produce appreciable noise levels observable above the general din.

Fortunately, energy conservation efforts can help to justify putting jackets on ice troughs. These jackets, if properly designed and maintained can also reduce noise levels associated with ice transport.

Ice drop stations also provide noise-generating mechanisms because of metal-to-metal and ice-to-metal contact. As a means of dealing with this problem, metal-to-metal contact can be minimized through gasketing of contact points. Ice-to-metal contact noise also can be minimized either by utilizing exterior vibration dampening material on the metal surfaces or by replacing the metal with plastic parts. Many modern plastics exhibit excellent strength qualities as well as vibration suppression qualities, making them ideal. As an example, an auto assembly plant has utilized a new plastic to replace a

metal component in its assembly line pull chain¹⁵. The plastic exhibited excellent strength characteristics while also greatly reducing chain noise.

Vibration Monitoring

As pointed out earlier, maintenance is an important feature in reducing overall noise emissions in poultry processing plants. One method of identifying machines in need of repair is to take periodic vibration readings on critical components itmes (such as motor drives, etc.).

We acquired a portable vibration meter, for approximately \$1,000, which was quite useful in taking quick and reasonably accurate vibration readings.* Our meter provided both velocity and displacement data. It was useful more than once in pinpointing excessive vibration levels.

*The meter purchased was a model 306 vibration meter manufactured by IRD Mechanalysis. This mention of the meter does not constitute its endorsement by the Georgia Tech Engineering Experiment Station or any of the project sponsors. This mention is for informational purposes only.

CONCLUSION

Workable solutions to the poultry processing plant noise problem do exist. Our study indicated, however, that care has to be given to durability and practicality.

In the area of absorption, a major weakness in current panel designs is the use of PVF film covers. On a typical panel, the cover amounts to approximately 10% of the total cost. If a stronger covering material is chosen, the cover could rise to nearly 40% of total cost, but it is the cover that is the critical design element of the panel. When it fails, the entire panel, not just the cover, must be replaced. Hence, we must conclude that cover design is a major factor in panel design and should impact panel selection.

We also concluded that using a vertical hanging arrangement is an efficient way to utilize noise panels. Our research showed that 3-foot spacings approximated the absorption characteristics, per square foot of ceiling covered, obtained by laying panels flat against the surface, but represented a one-third savings in the amount of material used. We also must note that through the use of a hanging arrangement, tighter spacing can be utilized to actually increase total absorption and to improve low-frequency absorption. However, these increases come at a progressively higher cost because of the greater volume of panels required to cover a given area.

In the area of source quieting, a major weakness was found in common plant maintenance procedures. Improperly maintained machines can very easily become major noise problems. A schedule of periodic vibration checks, using a portable vibration meter, is a good way to spot machinery in need of immediate attention.

Modifications to machine design, on the other hand, can reduce the potential impact of maintenance lapses. Chiller designs, for instance, should have drive motors and pumps decoupled from the main chiller body. Drive motors and pumps should be enclosed in hoods lined with absorbing medium. These measures can prevent a failing part from leading to a major noise problem.

Hock cutter noise seems to be attributable to the drive motor area. With the inclusion of an absorptive hood over the drive mechanisms, sound pressure levels near this device have the potential for significant reductions.

Lung gun noise, admittedly, is difficult to abate. Because of sanitary restrictions, we foresee no immediate quieting measure to deal directly with the noise-generating mechanisms. Automatic drawing machines do provide suitable substitutes, in many cases, to lung guns and have substantially lower noise levels because of the absence of a vacuum. Where a lung gun must be used, we believe partial barriers between the stations constitute a plausible solution for sound containment. However, to be fully effective, we further suggest that an absorbing hood be placed immediately over the station to minimize sound buildup.

Pneumatic tools should have exhaust mufflers placed on them to reduce noise levels in the immediate vicinity of their operation. Likewise, energy conservation measures can lead to lower noise from the ice transport system since insulation can be specified to reduce thermal loss and sound generation and transmission.

TEXT REFERENCES

1. J. C. Wyvill et al., A Study of Poultry Processing Plant Noise Characteristics and Potential Noise Control Techniques (Atlanta: Georgia Institute of Technology, Engineering Experiment Station, 1980), p. 32.
2. Personal conversation with Robert Huschle and G. T. Scheldahl.
3. Personal conversation with Cliff Miller, E. I. Du Pont de Nemours & Co., Inc.
4. American National Standards Institute, Standard Methods of Test for Sound Absorption of Acoustical Materials in Reverberant Rooms (ASTM C423-77), (New York, 1977), p. 3.
5. M. J. Crocker and A. J. Price, Noise and Noise Control (Vol. 1), (Cleveland: CRC Press, 1975), p. 229.
6. Ibid.
7. American National Standards Institute, op. cit., p. 2.
8. Philip M. Morse, Vibration and Sound, (New York: McGraw-Hill, 1948), p. 33.
9. J. B. Moreland, "Controlling Industrial Noise by Means of Room Boundary Absorption," Noise Control Engineering (November-December 1976), p. 148.
10. Crocker and Price, op. cit., p. 226.
11. J. C. Wyvill et al., loc. cit.
12. William M. Ihde, "Final Report of Noise Investigations for the Poultry Industry," Report to the Poultry Industry Advisory Committee on Safety and Health, March 22, 1973, p. 3.
13. Ibid.
14. Ibid., p. 4.
15. "UHMW Plastic Outdoes Hardened Steel," Design News, March 10, 1980, p. 39.

BIBLIOGRAPHY

- Banks, D. "Noise Reduction by the Use of Suspended Noise Absorbers and Acoustical Treatment," Noise Control Vibration and Insulation, October 1975, pp. 305-8.
- Beranek, Leo L. Noise and Vibration Control New York: McGraw-Hill, 1971.
- Crocker, M. J., and A. J. Price Noise and Noise Control Cleveland: CRC Press, 1975.
- "How to Get Out of a Jam with OSHA," Poultry Processing and Marketing, August 1977, pp. 19-21.
- Ihde, William M. Final Report of Noise Investigation for the Poultry Industry Report to the Poultry Industry Advisory Committee on Safety and Health, 1973.
- Mashburn, William, et al. Use of Acoustical Panels in a Poultry Processing Plant Blacksburg: Virginia Polytechnic Institute and State University, April 1, 1976.
- Moreland, J. B. "Controlling Industrial Noise by Means of Room Boundary Absorption Treatment," Noise Control Engineering, November-December 1976, pp. 148-53.
- Morse, Philip M. Vibration and Sound New York: McGraw-Hill, 1978.
- Wyvill, J. C., et al. A Study of Poultry Processing Plant Noise Characteristics and Potential Noise Control Techniques. Final Report for NASA Research Grant NSG 3228 and Georgia Department of Agriculture Research Project A-2028-006. Atlanta: Georgia Institute of Technology, Engineering Experiment Station, 1980.

APPENDIX A
BURN TEST ON TEMPERKOTE®



COMMERCIAL TESTING CO., INC.

SURFACE BURNING CHARACTERISTICS OF BUILDING MATERIALS
ASTM STANDARD METHOD OF TEST E 84-80

"FR/Film"

Test Number 1080-2538

Report Number 12048

Prepared for:

Georgia Institute of Technology
Atlanta, Georgia

Commercial Testing Company, Inc.

Jonathan Jackson
Executive Vice President

A-1

TESTING • RESEARCH • ENGINEERING

I. INTRODUCTION

This report is a presentation of results of the tunnel test on a material submitted for testing by Georgia Institute of Technology.

The test was conducted in accordance with the provisions of the American Society for Testing and Materials Standard Method of Test E 84-80, "Surface Burning Characteristics of Building Materials," also known as the Steiner Tunnel Test. This method is similar to ANSI 2.5, NFPA No. 255, UBC No. 42-1, and UL No. 723.

This standard should be used to measure and describe the properties of materials in response to heat and flame under controlled laboratory conditions. It should not be used for description, appraisal, or regulation of the fire hazards of materials under actual fire conditions. There are no considerations made for results that may be obtained if the material being evaluated were tested in combination with other building materials.

The fire performance of any material in the light of present knowledge cannot be evaluated on the basis of any one test. The test result presented here applies only to the specimen tested and is not necessarily indicative of apparent identical or similar materials. All test data are on file and are available for review by authorized persons.

II. PURPOSE

The tunnel test method is intended to compare the surface flame-spread and smoke developed measurements in relation to asbestos-cement board and select grade red oak flooring surfaces. A material is exposed to a flaming fire exposure adjusted to spread the flame along the entire length of a red oak specimen in 5½ minutes during a 10-minute test duration, while flamespread over its surface and density of the resulting smoke are measured and recorded. Test results are computed relative to the red oak specimen, which has a rating of 100, and the asbestos-cement board, which has a 0 rating, and are expressed as Flame Spread Index and Smoke Developed Index.

III. DESCRIPTION OF MATERIAL TESTED

CTC Test Number	- 1080-2538
Identification	- FR/Film
Composition	- Bonded Sailcloth/Polyester
Weight	- 2.5 ounces/yd ²

IV. PREPARATION AND CONDITIONING OF TEST SPECIMEN

The material being evaluated was adhered to 1/4 inch asbestos-cement flexboard with VPI #100 Epoxy Adhesive. The adhesive was applied to the board using a short-nap paint roller. The film was then placed into the adhesive and rubbed to remove entrapped air bubbles. The prepared specimen was then conditioned to equilibrium in an atmosphere maintained at 70°F and 50% relative humidity.

V. TEST PROCEDURE

The zero reference and other data critical to furnace operation were verified by conducting a 10-minute test using 1/4 inch asbestos-cement board on the day of the test. Periodic tests using NOFMA certified select grade red oak flooring provided data for the 100 reference. The material was then tested within parameters outlined in the standard test method procedure on January 27, 1981.

VI. TEST RESULTS

The test results, computed on the basis of observed flame front advance and the integrated area under the recorded curve of the smoke density apparatus, are presented in the following table. In recognition of possible variations in results due to limitations of the test method, the results are computed to the nearest number divisible by five.

<u>Test Specimen</u>	<u>Flame Spread Index</u>	<u>Smoke Developed Index</u>
asbestos-cement board	0	0
red oak flooring	100	100
(1080-2538) FR Film	10	25

Although not a requirement of ASTM E 84-80, Fuel Contributed may be reported for reference purposes. The Fuel Contributed is 0 for the material tested when computed in accordance with ASTM E 84-75.

The data for flamespread and smoke developed are shown as solid lines on the graph at the end of the report.

VII. OBSERVATIONS DURING TESTING

Ignition over the burners was noted at 0.86 minutes. The flame front advanced to 2.7 feet at 5.16 minutes with a maximum temperature recorded during the test of 576°F.

Slight dripping of the molten specimen occurred during the test. Blistering of the surface was noted after 0.5 minutes and continued throughout the test. There was no afterflame after the igniting burners were extinguished.

E 84-80 TUNNEL TEST DATA SHEET

CLIENT: GEORGIA INSTITUTE OF TECHNOLOGY
TEST NUMBER: 1080-2538
MATERIAL IDENTIFICATION: FR FILM
DATE: 27 JAN 81

TEST RESULTS:

TIME TO IGNITION = 0.86 MINUTES
DISTANCE MAXIMUM SPREAD = 2.7 FEET
TIME TO MAXIMUM SPREAD = 5.16 MINUTES

FLAMESPREAD CLASSIFICATION = 10
FUEL CONTRIBUTED = 0
SMOKE DEVELOPED = 25

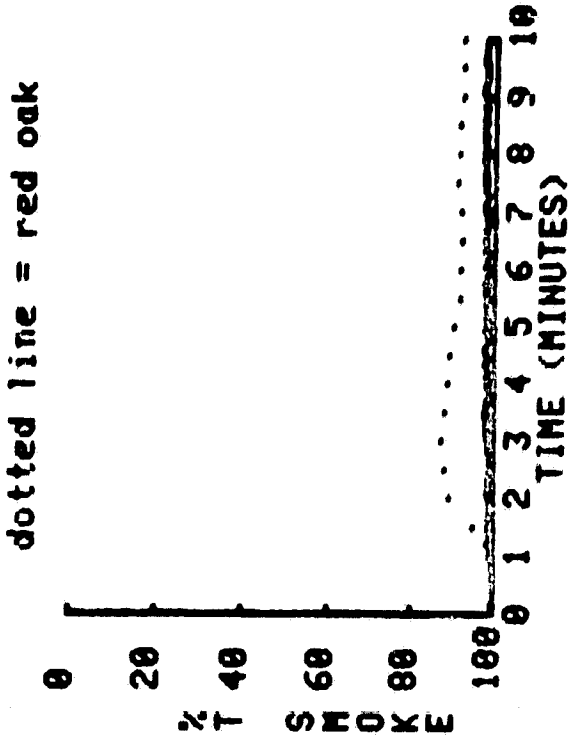
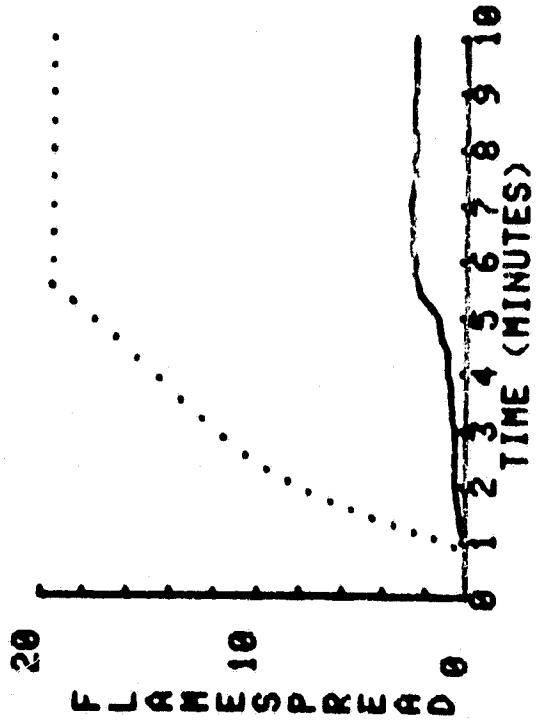

APPENDIX B

QUALIFYING A
REVERBERANT TEST ROOM

Qualifying a Reverberant Room

The reverberation chamber used for testing during this study was constructed of painted brick walls, a painted concrete floor, and a painted plywood ceiling. Per the suggestion of ANSI/ASTM C 423-77 and as more fully explained in Noise and Noise Control - Volume I, by M.J. Crocker and A. J. Price, nine stationary sound-reflective panels were hung at random orientations near the corner areas of the room. The reflective panels were constructed of 1/4" x 4' x 2' masonite sheets which were slightly curved to further break up any room resonance modes. These reflective panels were used to increase the diffusion of the sound field in the chamber and reduce the spatial variance of the sound decay measurements. Practically speaking, this meant that fewer microphone positions were required to achieve a given measurement precision.

Qualification tests on the reverberation chamber were performed to insure its suitability for obtaining meaningful acoustic measurements. The ANSI/ASTM C 423-77 standard requires that the average absorption coefficient of the room surfaces at each frequency be less than .06 after a correction for air absorption has been made. Using the equipment arrangement shown in Figure 1-A and the microphone positions shown in Figure 1-B, nine decay curves were observed for each microphone position.

The room absorption, in sabins, was then calculated from the ANSI/ASTM C 423-77 formula:

$$A_1 = \frac{.9210 \times V \times 60}{C} \times \frac{1}{T}$$

where

V = volume of room (ft³)

T = average time required for the sound field to decay 60dB (seconds)

C = speed of sound (ft/sec)

The average absorption coefficient of the room surfaces (α_R) was determined from the following formula:

$$\alpha_R = \frac{A_1}{S_R} - \frac{4mV}{S_R}$$

where

S_R = total surface area of room surfaces (ft²)

m = air absorption factor (@ 2000HZ = .000625 ft⁻¹ and @ 4000HZ = .001575 ft⁻¹.)

The results of the tests are shown in Table 1-A. From this table it can be seen that the average absorption coefficient of the room surfaces at each frequency is less than .06 as required by the standard.

Table 1-A

	500Hz	1000Hz	2000Hz	4000Hz
Spatially averaged T, in seconds	2.270	2.124	1.959	1.793
Spatial variance T, in % of T	1.40	2.50	2.19	2.52
Absorption, in sabine (A ₁)	77.63	82.97	89.96	98.29
Average α_R for room surfaces	.0485	.0519	.0562	.0614
Average α_R corrected for air absorption	.0485	.0519	.0505	.0471

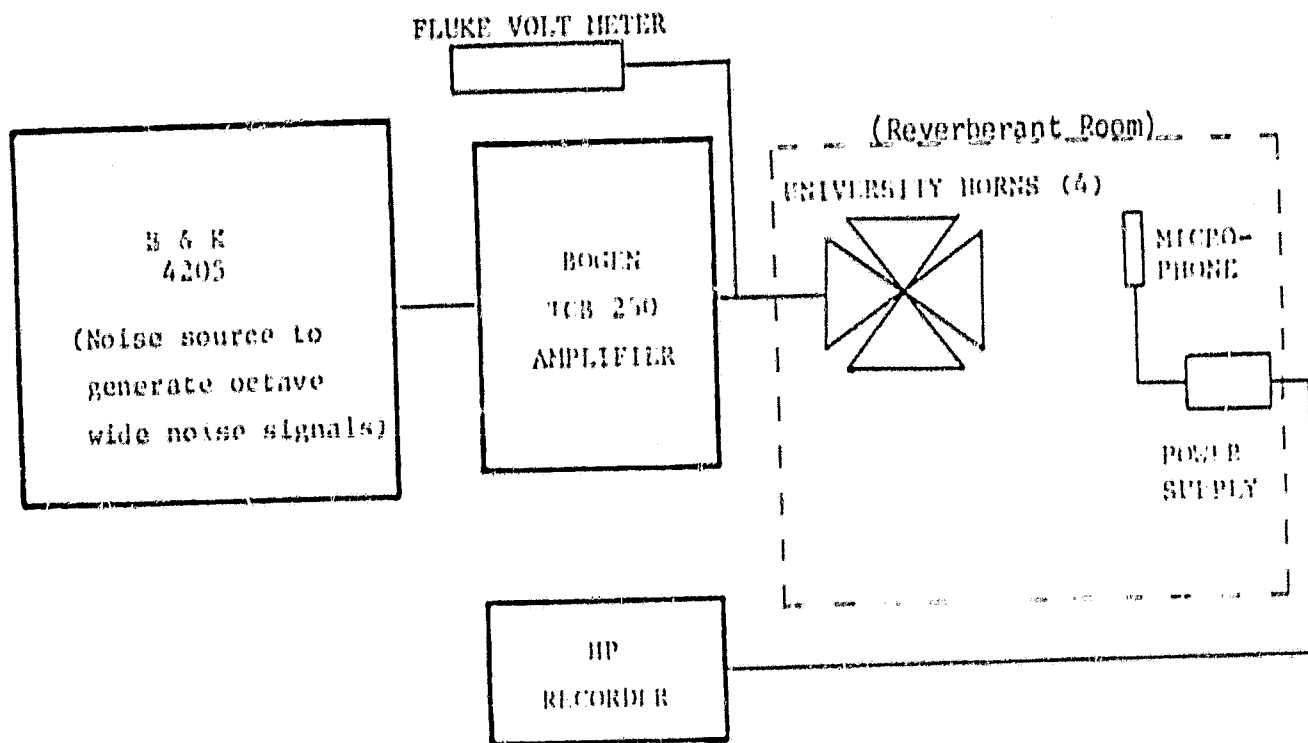
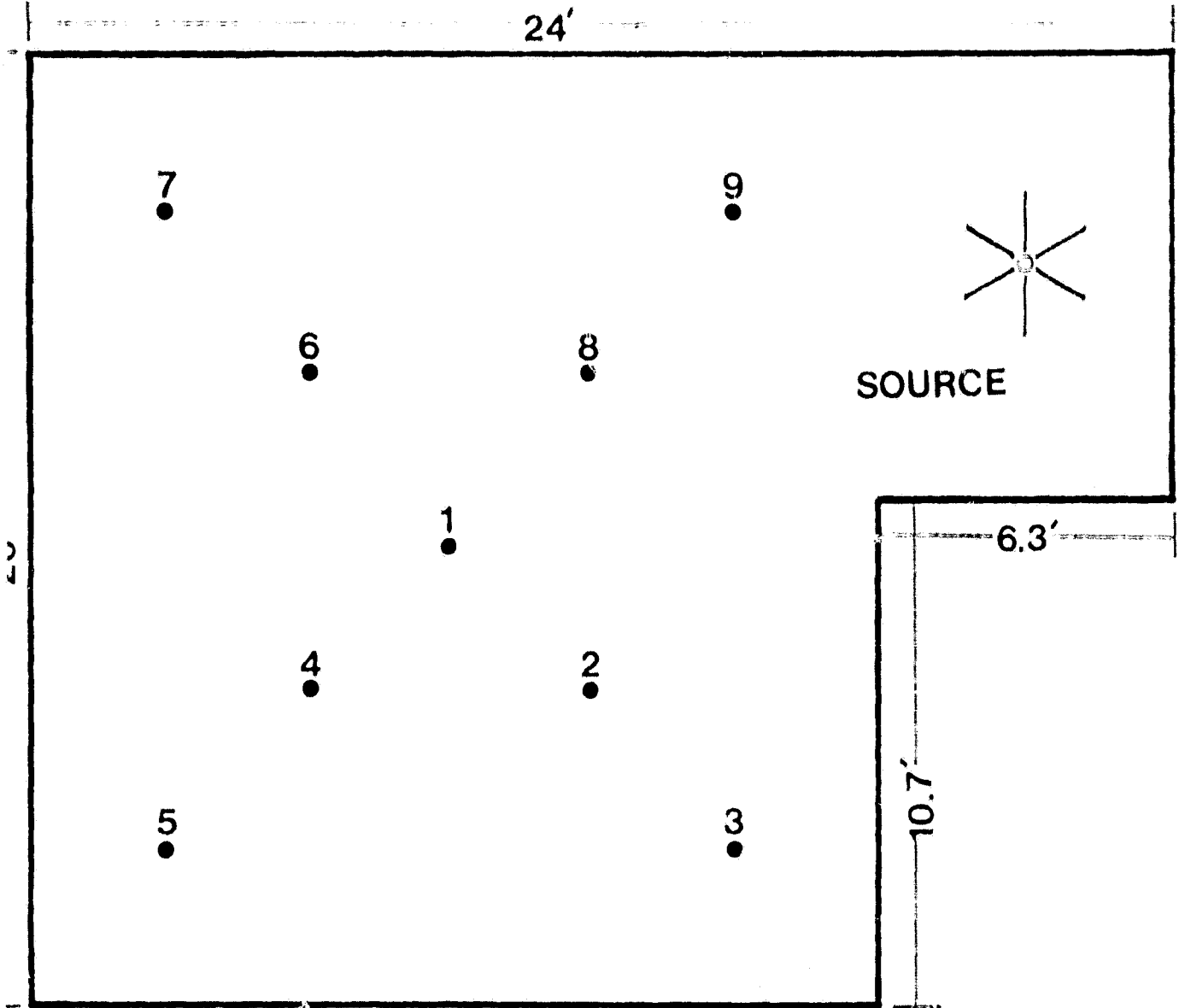

Figure 1-A - Equipment Arrangement



MICROPHONE HEIGHT - 3.4 ft

ROOM HEIGHT - 8.8 ft

END
DATE

JUL 14, 1981

Figure 1-B - Measurement Points in Reverberant Room.