



NASA CR-161,723

DOE/NASA CONTRACTOR
REPORT

DOE/NASA CR-161723

SOLAR ENERGY SYSTEM ECONOMIC EVALUATION--FINAL REPORT
FOR FERN TUNKHANNOCK, TUNKHANNOCK, PENNSYLVANIA

Prepared by

IBM Corporation
Federal Systems Division
150 Sparkman Drive
Huntsville, Alabama 35805

NASA-CR-161723
19810015997

Under Contract NAS8-32036 with

National Aeronautics and Space Administration
George C. Marshall Space Flight Center, Alabama 35812

For the U. S. Department of Energy

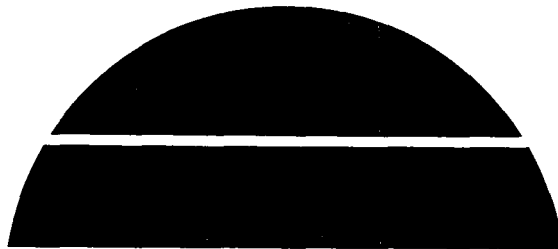

LIBRARY COPY
JUN 9 1981
NATIONAL AERONAUTICS AND SPACE ADMINISTRATION
WASHINGTON, D.C.

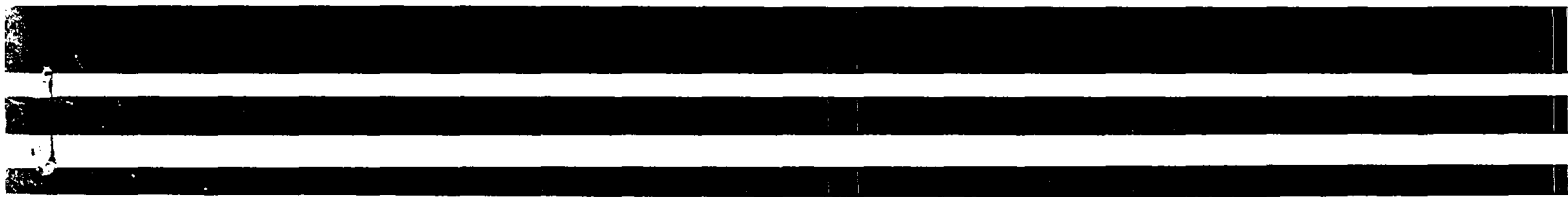

U.S. Department of Energy



NF01404



Solar Energy

NOTICE

This report was prepared to document work sponsored by the United States Government. Neither the United States nor its agents the United States Department of Energy, the United States National Aeronautics and Space Administration, nor any federal employees, nor any of their contractors, subcontractors or their employees, make any warranty, express or implied, or assume any legal liability or responsibility for the accuracy, completeness, or usefulness of any information, apparatus, product or process disclosed, or represent that its use would not infringe privately owned rights.

1. REPORT NO. DOE/NASA CR-161723		2. GOVERNMENT ACCESSION NO.		3. RECIPIENT'S CATALOG NO.	
4. TITLE AND SUBTITLE Solar Energy System Economic Evaluation Final Report for Fern Tunkhannock, Tunkhannock, Pennsylvania				5. REPORT DATE September 1980	
				6. PERFORMING ORGANIZATION CODE	
7. AUTHOR(S)				8. PERFORMING ORGANIZATION REPORT #	
9. PERFORMING ORGANIZATION NAME AND ADDRESS IBM Federal Systems Division 150 Sparkman Drive Huntsville, Alabama 35805				10. WORK UNIT NO.	
				11. CONTRACT OR GRANT NO. NAS8-32036	
12. SPONSORING AGENCY NAME AND ADDRESS National Aeronautics and Space Administration Washington, DC 20546				13. TYPE OF REPORT & PERIOD COVERED Contractor Report	
				14. SPONSORING AGENCY CODE	
15. SUPPLEMENTARY NOTES This work was done under the technical management of Mr. Cecil W. Messer, George C. Marshall Space Flight Center, Alabama.					
16. ABSTRACT <p>The Solar Energy Systems Economic Evaluation-Final Report has been developed by the George C. Marshall Space Flight Center as a part of the Solar Heating and Cooling Development Program funded by the Department of Energy.</p> <p>The economic analysis of the solar energy system that was installed at Tunkhannock, Pennsylvania is developed for this and four other sites typical of a wide range of environmental and economic conditions in the continental United States. This analysis is accomplished based on the technical and economic models in the f-chart design procedure with inputs based on the characteristics of the installed parameters of present worth of system cost over a projected twenty year life: life cycle savings, year of positive savings and year of payback for the optimized solar energy system at each of the analysis sites. The sensitivity of the economic evaluation to uncertainties in constituent system and economic variables is also investigated.</p> <p>The assumptions used in the economic analyses of this report are not typical of savings that could be realized in future installations of these types of solar heating and cooling systems. Although budget constraints preclude an economic reevaluation of each of the sites, a similar site, Carlsbad, New Mexico, was done. When 1985 escalated values for fuel, costs, mass production, and improved design installation techniques were applied, a significantly higher degree of savings was realized. Similar results could be expected for the site in this report.</p>					
17. KEY WORDS			18. DISTRIBUTION STATEMENT UC-59c Unclassified-Unlimited <i>William A. Brooksbank Jr</i> WILLIAM A. BROOKSBANK, JR. Mgr., Solar Energy Applications Projects		
19. SECURITY CLASSIF. (of this report) Unclassified		20. SECURITY CLASSIF. (of this page) Unclassified		21. NO. OF PAGES 100	22. PRICE NTIS

Intentionally Left Blank

TABLE OF CONTENTS

SECTION	TITLE	PAGE
1.	FOREWORD.	1
2.	SYSTEM DESCRIPTION.	3
3.	STUDY APPROACH.	6
3.1	INTRODUCTION	6
3.2	GROUNDRULES AND ASSUMPTIONS.	10
4.	ECONOMIC ANALYSIS	12
4.1	FACTORS IN LIFE CYCLE COSTS AND SAVINGS.	12
4.2	FEDERAL TAX CREDITS FOR SOLAR ENERGY SYSTEMS	18
5.	RESULTS OF ANALYSIS	19
5.1	TECHNICAL RESULTS.	19
5.2	ECONOMIC RESULTS	35
6.	ECONOMIC UNCERTAINTY ANALYSIS	55
7.	SUMMARY AND CONCLUSIONS	62
8.	REFERENCES	66
APPENDIX A	f-CHART PROCEDURE	A-1
APPENDIX B	ECONOMIC UNCERTAINTY ANALYSIS EQUATIONS	B-1
APPENDIX C	MONTHLY AVERAGE WATER SUPPLY TEMPERATURES	C-1
APPENDIX D	ENERGY COSTS FOR ANALYSIS SITES	D-1
APPENDIX E	COMPUTATION OF UA-VALUES.	E-1

LIST OF FIGURES AND TABLES

FIGURES	TITLE	PAGE
2-1	Fern Tunkhannock Solar Energy System Schematic	4
4-1	Life Cycle Savings vs. Collector Area for Four Sets of Economic Conditions.	17
5.1-1(a)-(e)	Solar Fraction vs. Collector Area for Solar Energy Systems at All Analysis Sites.	22-26
5.1-2(a)-(e)	Thermal Performance of Solar Energy System Over Analysis Period for All Sites With Optimized Solar System . .	27-31
5.2-1(a)-(e)	Optimization of Collector Area for All Analysis Sites . .	39-43
5.2-2(a)-(e)	Payback for Solar Energy Systems for All Analysis Sites .	45-49
5.2-3(a)-(e)	Annual Expenses for Solar System vs. Conventional System for All Analysis Sites.	50-54
7-1	Economic Summary Chart for All Analysis Sites	63

TABLES	TITLE	PAGE
5.1-1	Solar System Load Factors and Environmental Parameters. .	21
5.1-2	f-Chart Input Variables	32
5.1-3	Solar System Technical Parameters for f-Chart Program . .	34
5.2-1	Costs and Savings Over 20 Year Analysis Period.	44
6-1	Uncertainty Analysis for Fern Tunkhannock	57
6-2	Uncertainty Analysis for Albuquerque, NM	58
6-3	Uncertainty Analysis for Fort Worth, TX	59
6-4	Uncertainty Analysis for Madison, WI	60
6-5	Uncertainty Analysis for Washington, DC	61

1. FOREWORD

The Solar Energy System Economic Evaluation - Final Report has been developed by the George C. Marshall Space Flight Center as a part of the Solar Heating and Cooling Development Program funded by the Department of Energy. The analysis contained in this document describes the economic performance of an Operational Test Site (OTS). The objective of the analysis is to report the long-term economic performance of the system at its installation site and to extrapolate to four additional locations which have been selected to demonstrate the viability of the design over a broad range of environmental and economic conditions.

The contents of this document are divided into the following topics:

- System Description
- Study Approach
- Economic Analysis and System Optimization
- Results of Analysis: Technical and Economic
- Economic Uncertainty Analysis
- Summary and Conclusions

The data used for the economic analysis have been generated through evaluation of the Operational Test Site described in this document. The data that have been collected, processed, and maintained under the OTS Development Program provide the resource from which inputs to the simulation programs used to perform technical and economic analysis are extracted.

The Final Report document, in conjunction with the Seasonal Report [3]* for each Operational Test Site in the Development Program, culminates the technical

*Numbers in brackets designate references found in Section 8.

activities which began with site selection and instrumentation system design in April, 1976. The Seasonal Report emphasizes the technical analysis of solar systems performance. It compares actual performance with predicted performance derived through simulation methods where actual weather and loads defined the inputs. The simulation used for final report analysis is based on the technical results of the seasonal report simulation, with the exception that long-term weather, and derived loads are used as inputs instead of measured weather and loads. This causes the expected value of solar system performance in the Seasonal and Final Reports to differ. In addition localized and standard economic parameters are used for economic analysis in the final report evaluation. The details of the simulation program are described in References [4] and [5]. Other documents specifically related to the solar energy system analysed in this report are [1] and [2].

2. SYSTEM DESCRIPTION

The Fern* Tunkhannock solar energy system was designed to provide both space heating and domestic hot water preheating for a 1,000 square foot single-family residence in Tunkhannock, Pennsylvania. Solar energy collection is accomplished with flat-plate collectors using air as the transport fluid. The collector array has a gross area of 208.5 square feet and faces 15 degrees west of south at an angle of 45 degrees from the horizontal. Energy is transferred to and from storage by means of a liquid-to-air heat exchanger. Storage capacity is 240 gallons of water in the main tanks (two tanks of 120 gallons each) and 40 gallons in the domestic hot water tank. Auxiliary energy for the hot water subsystem is provided by electricity, and for the space heating subsystem by fuel oil. The hot water heater is rated at 4kw, and the space heating furnace at 100,000 Btu/hr. The system, shown schematically in Figure 2-1, has five modes of operation. The sensor designations in Figure 2-1 are in accordance with NBSIR-76-1137 [6]. The measurement symbol prefixes: W, T, EP, I and F represent respectively: flow rate, temperature, electric power, insolation, and fossil fuel consumption.

Mode 1 - Collector-to-Space Heating: In this mode, solar heated air is delivered directly from the collector array to the conditioned space. This mode is entered whenever there is a demand for space heating and the collector array temperature exceeds 95°F.

Mode 2 - Storage-to-Space Heating: This mode is entered whenever a demand for space heating exists, there is insufficient solar radiation available to directly satisfy this demand, and if the storage tank temperature is high enough (95°F) to supply useful energy. In this mode, heated water is taken from storage and circulated through the liquid side of the liquid-to-air heat exchanger located in the heating system supply duct. Air is then passed through the air side of the heat exchanger, where it is warmed for delivery to the house.

*Solafern Ltd., formerly Fern, Inc. is the system contractor.

- I001 COLLECTOR PLANE TOTAL INSOLATION
- V001 WIND SPEED
- D001 WIND SPEED DIRECTION
- ▼ T001 OUTDOOR TEMPERATURE

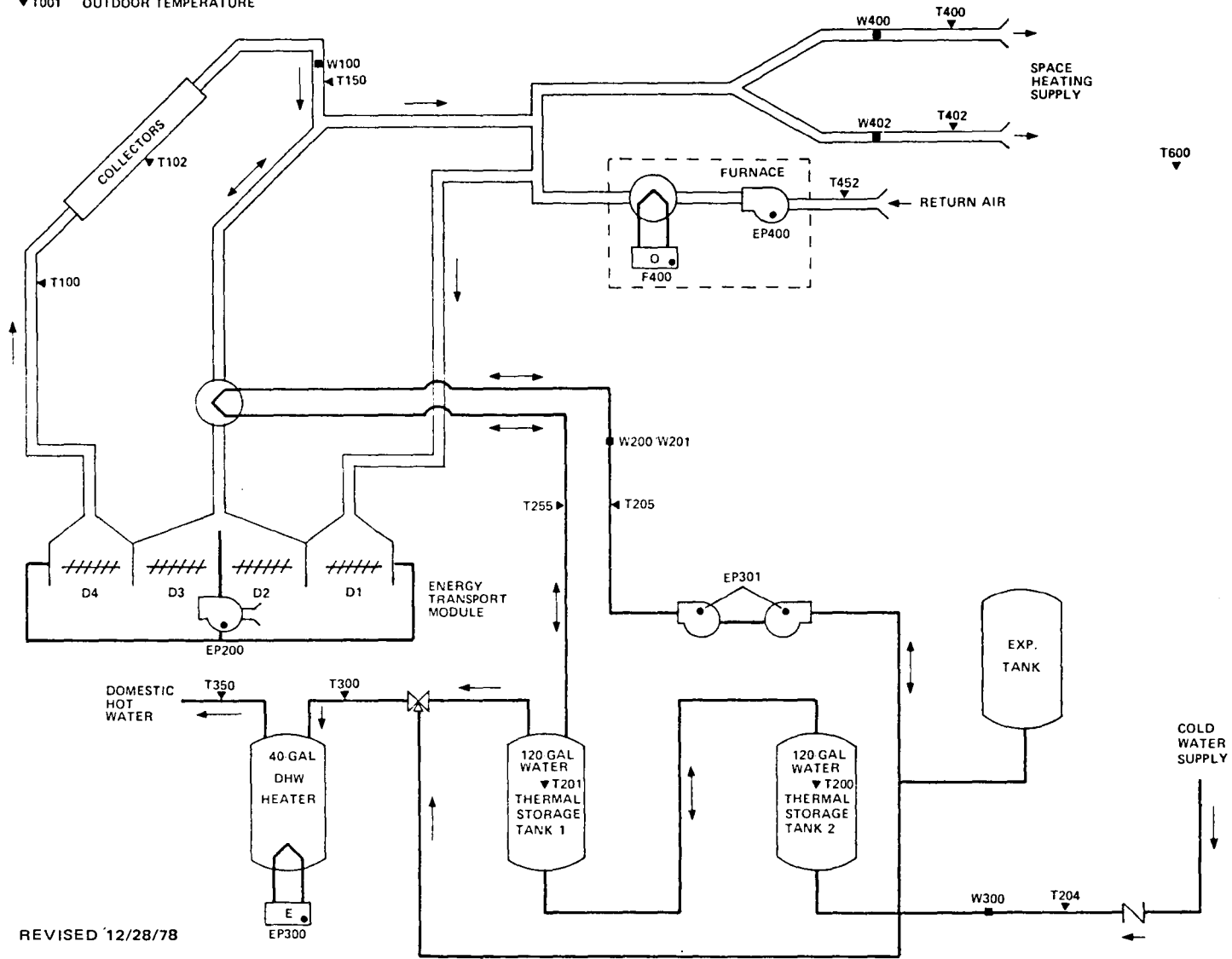

Figure 2-1 Fern Tunkhannock Solar Energy System Schematic

Mode 3 - Collector-to-Storage: The system operates in this mode whenever the space heating demands have been satisfied and additional solar energy is available for heating storage. A differential of 20°F between collector and storage is required before collected energy can be delivered to storage. Solar heated air is passed through the heat exchanger where it warms water that is being circulated from the storage tanks.

Mode 4 - Domestic Hot Water Preheating: This mode exists whenever there is a demand for hot water. Makeup water is delivered to storage where it is preheated before going to the hot water heater.

Mode 5 - Collector-to-Storage and Auxiliary Space Heating: This mode is entered whenever the room thermostat is raised 3°F or more above the solar energy system activation temperature, or if the room temperature drops 3°F below the solar energy system activation temperature. Under these circumstances, auxiliary energy is used to heat the house and any available solar energy is delivered to storage. When the house temperature recovers, the system will switch back to the direct Collector-to-Space Heating mode.

3. STUDY APPROACH

3.1 Introduction

The Final Report is an economic evaluation of the solar energy system (based on life cycle costs versus energy savings) for five cities which are considered to be representative of a broad range of environmental and economic conditions in the United States. Life cycle costs provide a measure of the total costs of owning and operating a system over the life of the system rather than focusing solely on the initial cost of the system. The life cycle costs used in this evaluation consider hardware, installation, maintenance, and operating costs for the solar-unique components of the total system. Energy savings result from replacement of conventional forms of energy by solar energy after the costs of producing the solar energy are deducted. The total system operates in a scenario that comprises long-term average environmental conditions, loads, fuel costs and other economic factors that are applicable in each of five cities.

The five cities include four standard analysis sites which were selected according to the criteria listed below and the site where the system was, in fact, installed and operated. The selection criteria were based on:

- Availability of long-term weather data
- Heating degree days (load related factor)
- Cold water supply temperature (load related factor)
- Solar insolation
- Utility rates
- Market potential
- Type of solar system

To achieve the range of environmental and economic parameters desired, the four locations listed below plus the actual installation location, were used. A solar energy system buyer may evaluate his own local environmental and economic conditions relative to those considered in this Final Report by comparing the insolation available, the heat load, and the utility rates against the results reported in Section 5.

Albuquerque, NM

1828 Btu/Ft²-Day average insolation*
Medium heating load (4292 Heating Degree Days (HDD))
High utility rates (> 0.06 \$/kWh)**
Fuel oil rates (7.41 \$/Million Btu)***

Fort Worth, TX

1475 Btu/Ft²-Day average insolation*
Light heating load (2382 HDD)
Medium utility rates (0.04-0.06 \$/kWh)**
Fuel oil rates (7.03 \$/Million Btu)***

Madison, WI

1191 Btu/Ft²-Day average insolation*
High heating load (7730 HDD)
Medium utility rates (0.04-0.06 \$/kWh)**
Fuel oil rates (6.54 \$/Million Btu)***

Washington, DC

1208 Btu/Ft²-Day average insolation*
Medium heating load (5010 HDD)
High utility rates (> 0.06 \$/kWh)**
Fuel oil rates (7.42 \$/Million Btu)***

Tunkhannock, PA

1086 Btu/Ft²-Day average insolation*
High heating load (6277 HDD)
Medium utility rates (0.04 - 0.06 \$/kWh)
Fuel oil rates (6.79 \$/Million Btu)***

The parameters that define the system design were derived from the actual operating conditions of the system at the installation site. Solar energy system design may be economically optimized for the site at which the

*Insolation values are average daily long-term values on a horizontal surface.

**Utility rates are effective year-round averages based on 1000 kWh for January, 1980. See Appendix D.

***See Appendix D for fuel oil rate computation.

system is installed. The fundamental objective in optimizing the design of a solar energy system on an economic basis is to minimize cost by allocating the required amount of energy between the solar and conventional portions of the system. To attain this objective, each unit of energy should be produced by the portion of the total system which generates the lowest incremental cost in producing that additional unit of energy. This is accomplished in the final report analysis by determining the optimal solar energy system size (collector area or equivalently, solar fraction).

In the Operational Test Site (OTS) Development Program there are many solar energy systems designed by many different contractors. Some of the designs were installed in new buildings and some were retrofitted to existing buildings. Consequently, there are a variety of factors which contributed to the design of a system at a given site. In some cases the objective of optimizing the design according to the previously stated criterion could not be met. A method of evaluation which establishes a common basis for evaluation of all these systems was required. The method selected is to optimize the collector size through the f-Chart [4], [5] design procedure. F-Chart is a design program developed by the University of Wisconsin for solar heating and/or domestic hot water systems. The program uses a set of design charts (developed by detailed simulations) which estimate the thermal performance of a solar system based on collector characteristics, storage, energy demands, and regional long-term weather data. Using the results of thermal analysis, an iterative procedure is implemented to select a collector area which minimizes the life cycle costs. Once the optimal collector size has been determined, the resulting thermal and economic performance can be obtained.

The resolution of two inter-related problems was required in order to adapt f-Chart to the evaluation developed in the Final Report. The first was how to use the data and experience gained from the actual operation of the solar energy system; the second was what procedure to follow in view of the fact that all solar energy systems to be analysed do not have optimal collector

area sizing. To resolve the first problem, the characteristics of design and operation of the existing solar energy system were used to develop the input parameters for f-Chart. This procedure, detailed in Appendix A, involved the normalization of collector flow rates and storage capacity to collector area. Collector characteristics developed from field data through a collector analysis program were substituted for the theoretical single panel parameters furnished by the collector manufacturers. To resolve the problem of different collector areas, an optimal collector area was derived for each site. The final adaption of f-Chart includes the inputs derived from operational data and optimal collector area.

In addition to the f-Chart problems described above, certain internal modifications were required to enable the economic analysis of space heating and domestic hot water systems where the auxiliary energy sources were fossil fuels. This involved the modification of the loads from which the economic parameters were computed. To modify the loads two coefficients of performance, i.e., SHCOP for the space heating system and HWCOP for the hot water system, which are described in Appendix A were introduced. These COP's are used to adjust the cost of fossil fuel auxiliary energy, considering the efficiency of the respective systems, relative to the cost of electrical energy at each analysis site.

As the system application at each of the five analysis sites is studied, the loads are iteratively redefined, the site peculiar parameters are changed as described in Appendix A, and a new optimal collector area is computed. The economic factors are the result of the f-Chart analysis with these inputs.

3.2 Groundrules and Assumptions

The cost differential between solar and the conventional system is significant to the economic evaluation in the Final Report. Cost items which were equal for both alternatives do not contribute to the differential cost. The cost of the conventional system was assumed to be identical with or without the solar alternative. Although a conventional system is usually selected according to the availability and cost of energy in a particular geographic region, this alternative is not permitted in the final report analysis because an existing system is being evaluated. Savings which might be realized by comparing solar against an auxiliary other than the design option were not evaluated. The system configuration, including the conventional auxiliary, is the same for all five analysis sites.

The cost of the solar-unique hardware is based on mass production estimates. The total incremental costs for acquisition of a solar alternative are the sum of a cost proportional to collector area and a cost independent of collector area. For economic evaluation, life cycle costs (i.e., costs of acquiring, operating and maintaining the solar systems) were forecast on an annual basis over the design lifetime of the system, then discounted to an equivalent single constant dollar (1980) value as described in Section 4.

Fuel costs are calculated at current (1980) local values for each of the five analysis sites. Other economic parameters are standardized by referencing current national economic conditions. Maintenance, insurance, depreciation, system life, salvage values (for commercial systems) are determined from best experience. Tax credits allowed by the Federal Government for the solar energy systems are credited against the acquisition cost. A combined state and federal income tax rate of 30 percent is assumed for estimating tax savings resulting from the interest paid

in financing a solar system. Property taxes arising from the increased value of property with an installed solar system are neglected due to the current trend in many states to forego these taxes to prevent them from being a disincentive to solar energy usage.

The primary measure of cost effectiveness of the solar system for the evaluation in the Final Report is:

- Life Cycle Cumulative Savings (LCCS) - The present value of the cumulative energy savings (in dollars) that result from operation of the solar system instead of the conventional system.

Two secondary measures that depend on life cycle cumulative savings are:

- Year of Positive Savings - Year in which solar system first becomes profitable; i.e., the annual conventional fuel bill without solar exceeds the sum of the annual fuel bill with solar and the annual cost for the solar system.
- Year of Payback - Year in which the compounded net savings equals the initial cost for the solar system. Net savings are computed with respect to the fuel cost of the conventional system.

4. ECONOMIC ANALYSIS

4.1 Factors in Life Cycle Costs and Savings

The economic calculations of this study are performed in the f-Chart program and are based on comparisons of life cycle costs of conventional energy systems with those of solar energy systems. The life cycle savings of a solar energy system over a conventional energy system can be expressed as the difference between the total fuel savings that result from operation of the solar energy system and the increased costs that result from the investment in, the operation of, and maintenance of the solar energy system. The savings can be expressed by the relationship [7]:

$$LCCS = P_1 (C_{FE}L_E + C_{FF}L_F/COP_F)F - P_2(C_A A + C_E) \quad (1)$$

where LCCS = Life cycle cost savings of the solar energy system (\$) in terms of present worth

P_1 = Factor relating life cycle fuel cost savings to first year cost savings

C_{FE} = Electrical energy cost per unit (\$/Million Btu)

COP_F = Heating system coefficient of performance (or efficiency (η_F))

L_E = Hot water load (Million Btu)

L_F = Space heating load (Million Btu)

F = Solar fraction

P_2 = Factor relating life cycle investment operation and maintenance expenditures to the initial investment

C_A = Solar energy system costs dependent on the collector area (\$/Ft²)

A = Collector area (Ft²)

C_E = Solar energy system costs that are independent of collector area. (\$)

It was assumed that the costs of components which were common to both conventional and solar heating systems (e.g. the furnace, ductwork, blowers, thermostat), and the maintenance costs of this equipment, are identical. Consequently, all references to solar energy system costs refer to the cost increment above the common costs.

The multiplying factors, P_1 and P_2 , facilitate the use of life cycle cost methods in a compact form. Any cost which was proportional to either the first year fuel cost or the initial investment can be included. These factors allow for variation of annual expenses with inflation and reflect the time value* of money by discounting future expenses to present dollar values.

To illustrate the evaluation of P_1 and P_2 , consider a simple economic situation in which the only significant costs are fuel and system equipment costs. The fuel cost is assumed to escalate at a constant annual rate, and the owner pays cash for the system. Here, P_1 accounts for fuel escalation and the discounting of future payments. The factor P_2 accounts for investment related expenses which in this case, consist only of the investment which is already expressed in current dollars. The factors P_1 and P_2 are then

$$P_1 = \text{PWF}(N, e, d) \quad (2)$$

$$P_2 = 1$$

where N = Period of economic analysis (yrs)

e = Escalation rate of fuel price

d = Annual discount rate

*Discounting refers to the fact that an expense that is anticipated to be \$1000 in 10 years is equivalent to an investment today of \$463 at a discount rate of 8%.

The function $PWF(N, e, d)$ is the present worth factor that accounts for inflating payments in discounted money.

$$PWF(N, e, d) = \frac{1}{d - e} \left[1 - \left(\frac{1 + e}{1 + d} \right)^N \right] \quad (3)$$

When multiplied by a first period cost (which is inflated at a rate, e , and discounted at a rate, d , over N years), the resulting value is the present worth life cycle cost.

In the more complex analysis the expenditures incurred by the additional capital investment cause P_1 and P_2 to take the following form:

$$P_1 = (1 - C\bar{t}) PWF(N, e, d) \quad (4)$$

$$P_2 = P_{21} + P_{22} - P_{23} + P_{24} + P_{25} - P_{26} - P_{27} \quad (5)$$

where P_{21} = Factor representing the down payment

P_{22} = Factor representing the life cycle cost of the mortgage principal and interest

P_{23} = Factor representing income tax deductions for interest payment

P_{24} = Factor representing miscellaneous costs (maintenance, insurance, etc)

P_{25} = Factor representing net property tax costs

P_{26} = Factor representing straight line depreciation tax deduction for commercial installations

P_{27} = Factor representing salvage (commercial installation) or resale value (residential installation).

The factors P21 through P27 are defined as follows:

$$P21 = D \quad (6)$$

$$P22 = (1 - D) \text{PWF}(N, 0, d) / \text{PWF}(N, 0, i) \quad (7)$$

$$P23 = (1 - D) \bar{t} \left\{ \text{PWF}(N, i, d) \left[i - 1 / \text{PWF}(N, 0, i) \right] + \text{PWF}(N, 0, d) / \text{PWF}(N, 0, i) \right\} \quad (8)$$

$$P24 = (1 - C\bar{t}) \text{MPWF}(N, g, d) \quad (9)$$

$$P25 = t (1 - \bar{t}) \text{VPWF}(N, g, d) \quad (10)$$

$$P26 = (C\bar{t}/N) \text{PWF}(N, 0, d) \quad (11)$$

$$P27 = G / (1 + d)^N \quad (12)$$

where D = Ratio of down payment to the initial investment

N = Period of analysis (Note that the period of analysis, the term of the loan, the depreciation lifetime, and the years over which the depreciation deductions contribute to the analysis are arbitrarily set equal in this report).

d = Discount rate (after tax return on the best alternative investment)

i = Annual mortgage interest rate

\bar{t} = Effective income tax rate

C = Commercial or non-commercial flag (1 or 0 respectively)

M = Ratio of first year miscellaneous costs to
initial investment

g = General inflation rate

t = Property tax rate based on assessed value

V = Ratio of assessed value in first year to initial
investment

G = Ratio of salvage or resale value to initial
investment

For a given location, heating load, and economic situation, it is possible to optimize the system design variables to yield the maximum life cycle savings. The main solar energy system design variable is the collector area. The effect of collector area on the life cycle savings is illustrated in Figure 4-1 for the four sets of economic conditions. Curve A corresponds to an economic scenario in which solar energy cannot compete with the conventional system. Curve B exhibits a non-zero optimum area, but the conventional system is still the most economical. Curve C corresponds to the critical condition where solar energy can just compete with the conventional system. Curve D corresponds to an economic scenario in which the solar energy system is the most economical.

Each curve of Figure 4-1 begins with a negative savings for zero collector area. The magnitude of this loss is C_E , and reflects the presence of solar energy system fixed costs in the absence of any fuel savings. As the collector area increases Curves B, C, and D show increased savings until reaching a maximum at some optimum collector area. As the collector area is further increased, the fuel savings continue to increase, but the excessive system cost forces the life cycle savings of the system to decrease. These collector areas at each of the five analysis sites listed in this report have been optimized by the f-Chart program analysis technique for the long-term average weather conditions and the economic conditions at that site.

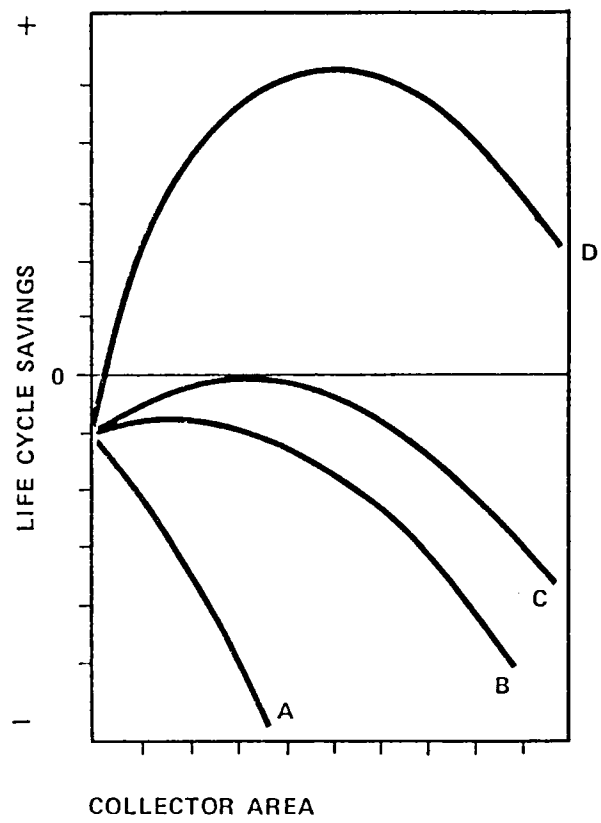

Figure 4-1 Life Cycle Savings versus Collector Area for Four Sets of Economic Conditions

4.2 Federal Tax Credits for Solar Energy Systems

The Federal Government has provided tax incentives that are applicable to solar energy systems after 1979. This credit is 40 percent of the first \$10,000 spent on solar equipment, or a maximum credit of \$4,000. The credit is applied in this analysis by reducing both the collector area dependent cost and the cost independent of the collector area, or constant solar cost, by an effective credit factor based on the total cost of the system.

As an example of the tax credit computation, assume the collector area dependent cost is \$30/Ft² based on 100 Ft² and the constant solar cost is \$900 for a total price of \$3900. The effective credit factor is 0.4 since the system cost is less than \$10,000.

Therefore the adjusted costs used as f-Chart inputs are:

$$\frac{\text{Collector area dependent cost}}{C_A'} = \$30 \times (1 - 0.4) = \$18.00/\text{Ft}^2$$

$$\frac{\text{Constant solar cost}}{C_E'} = \$900 \times (1 - 0.4) = \$540$$

If the system cost had exceeded \$10,000 the effective credit factor would have been the ratio of the maximum credit (\$4,000) to the total system cost.

The f-Chart economic analysis is modified by using these adjusted costs to reflect tax credit effects. Including tax credit in area optimization is an iterative process since the credit is affected by the system size and vice versa. Optimal collector area is modified in this analysis, as are the f-Chart economic parameters, by use of the tax credit. Items 23 and 24 in Table 5.1-2 reflect the solar costs after application of tax credits in terms of collector area dependent cost and constant cost. Initial system costs before and after tax credit inclusion are shown in Table 5.2-1 for each site based on optimal collector area.

5. RESULTS OF ANALYSIS

5.1 Technical Results

For each of the five analysis sites an optimal solar system based on the configuration of the actual installation is determined by using the f-Chart design procedure. The environmental parameters and the loads used in this procedure for each of the five sites are shown in Table 5.1-1. In applying the design procedure a process that iterates on the collector area is used. Figures 5.1-1 (a) - (e) show the results of that design procedure in terms of the expected solar fraction versus the collector area for each site. The expected solar fraction is the ratio of the expected solar energy used toward satisfying the load to the total load. The graphs in Figures 5.1-1 (a) - (e) show that as the collector areas increases, the expected solar fraction increases. However, the economically optimal collector area was selected to maximize the economic benefits of the solar energy system, not the expected solar fraction. The optimal collector area is shown by the dotted line for each site. Increasing the collector area beyond the optimal value forces a diminishing return on the investment for the system. The expected solar fraction for the optimal collector area is shown in the last column in Table 5.1-1.

The resulting thermal performance, once the optimal size system is selected, is shown in the graphs of Figures 5.1-2 (a) - (e) for each analysis site. The incident solar energy is derived from long-term average insolation at the site. The total load is computed based on design parameters of the actual system as installed, modified by environmental conditions at each site. The load calculations are detailed in Appendix A. The useful solar energy is the product of the system solar fraction and the total load. It shows on a month by month basis the portion of the total load that is expected to be supplied by solar energy. The shaded portion between the total load curve and the curve of useful solar energy must be supplied by conventional energy.

Optimal collector areas for the analysis sites ranged from a low of 209 square feet at Fort Worth, Texas to a high of 313 square feet at Albuquerque, New Mexico as shown in Figures 5.1-1(a) - (e). Figures 5.1-2(a) - (e) show that the highest "Individual Solar Energy" and

therefore, the highest "Useful Solar Energy" was in Albuquerque, New Mexico where Table 5.1-1 shows the solar fraction to be 80.8% of the total load for this system. Table 5.1-1 also shows that this system provided 65.2% of the heating and hot water load for the Fort Worth, Texas site based on its optimized collector area.

The technical parameters that uniquely describe this solar energy system are listed in Table 5.1-2 as Items 1 through 21 and Items 47 and 48 and described in detail in Appendix A. Their values are listed by site in Table 5.1-3. The remaining technical parameters are assigned values which are constant for all sites.

The economic parameters for the solar energy system are listed in Table 5.1-2 as Items 22 through 46, and are also described in Appendix A with the source for the assigned value designated.

The following items are a function of the analysis site.

- Collector area
- Collector slope
- Azimuth angle
- Effective building UA (applicable to space heating systems)
- Water main temperature
- Present cost of solar backup fuel
- Present cost of conventional fuel

These are listed by site in Table 5.1-3.

SUMMARY TABLE

TABLE 5.1-1

SOLAR SYSTEM LOAD FACTORS AND ENVIRONMENTAL PARAMETERS

SITE	TOTAL ANNUAL LOAD (MILLION BTU)		ENVIRONMENTAL PARAMETERS - LONG-TERM			EXPECTED
	HEATING	HOT WATER	INSOLATION BTU/FT ² -DAY	HEATING DEGREE DAYS	SUPPLY WATER TEMP (°F)	SOLAR FRACTION*
TUNKHANNOCK	26.44	15.03	1086	6277	62	33.0
ALBUQUERQUE	19.63	12.96	1828	4292	73	80.8
FORT WORTH	10.19	14.56	1475	2382	65	65.2
MADISON	30.83	16.62	1191	7730	54	36.7
WASHINGTON	22.50	15.56	1208	5010	60	45.9

* For optimal collector area

TUNKHANNOCK, PENNSYLVANIA
OPTIMAL COLLECTOR AREA = 243FT²

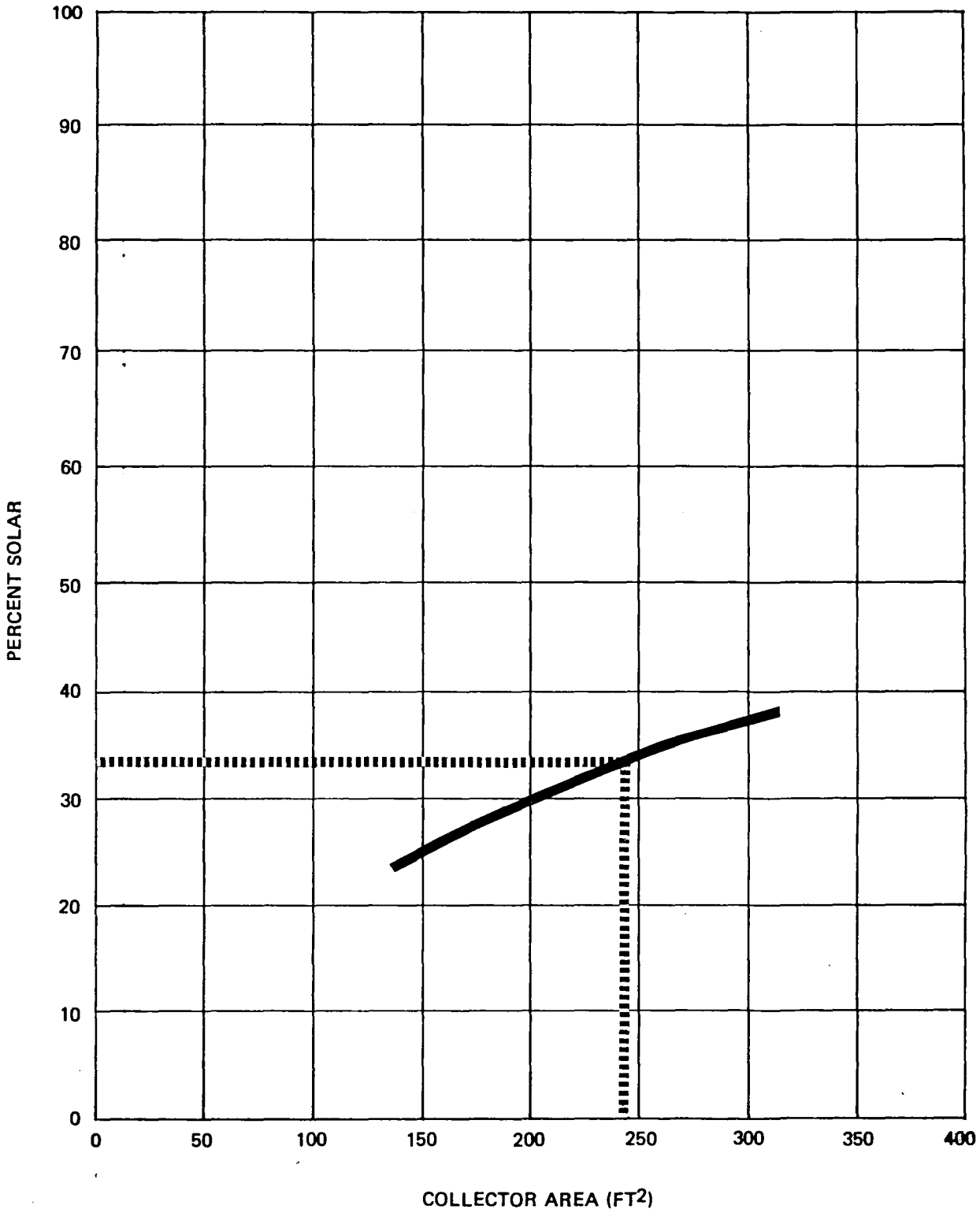

Figure 5.1-1 (a) Solar Fraction vs Collector Area for Solar Energy System at Tunkhannock, Pennsylvania

ALBUQUERQUE, NEW MEXICO
OPTIMAL COLLECTOR AREA = 313 FT²

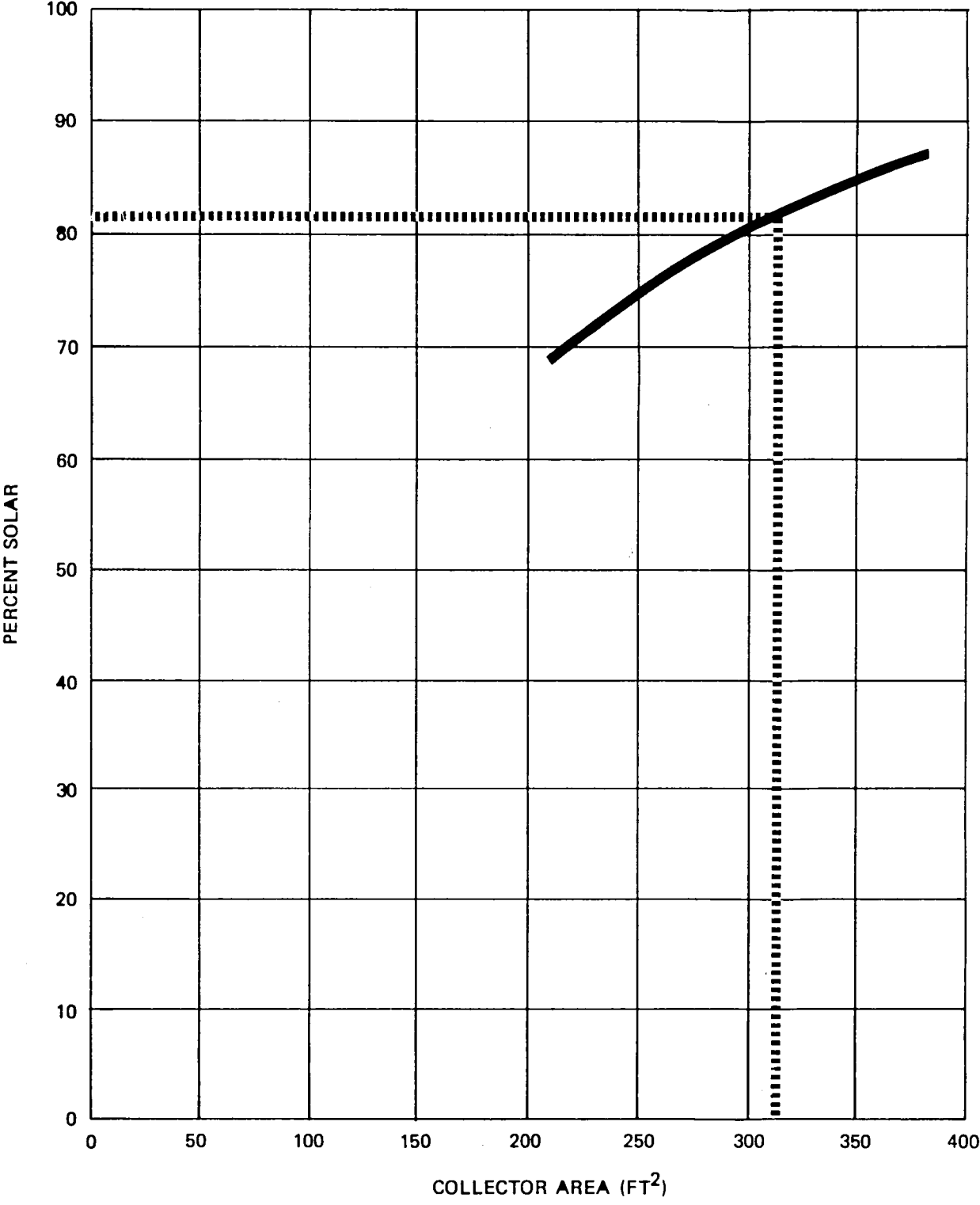

Figure 5.1-1 (b) Solar Fraction vs Collector Area for Solar Energy System at Albuquerque, New Mexico

FORT WORTH, TEXAS
OPTIMAL COLLECTOR AREA = 209 FT²

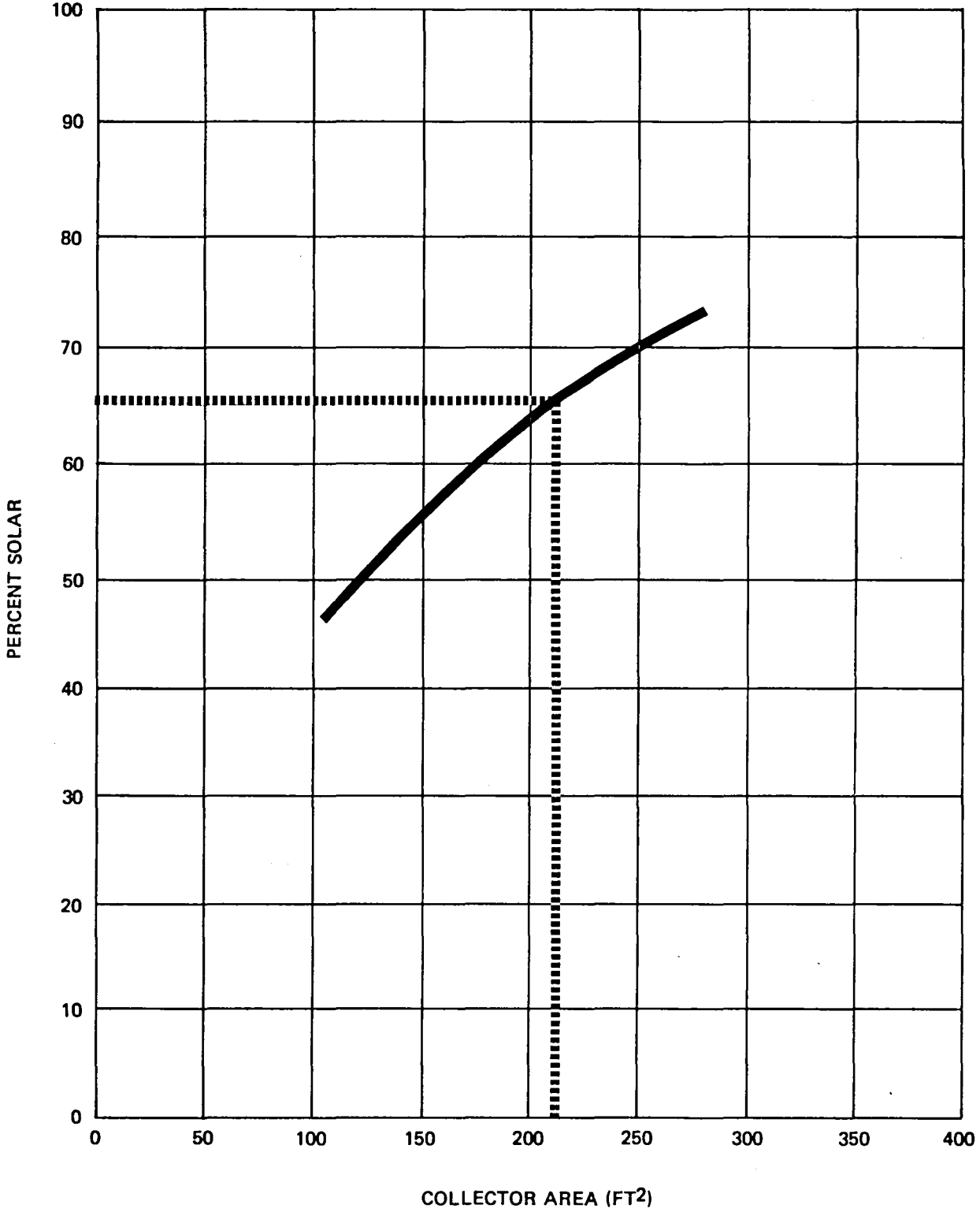

Figure 5.1-1 (c) Solar Fraction vs Collector Area for Solar Energy System at Fort Worth, Texas

MADISON, WISCONSIN
OPTIMAL COLLECTOR AREA = 243 FT²

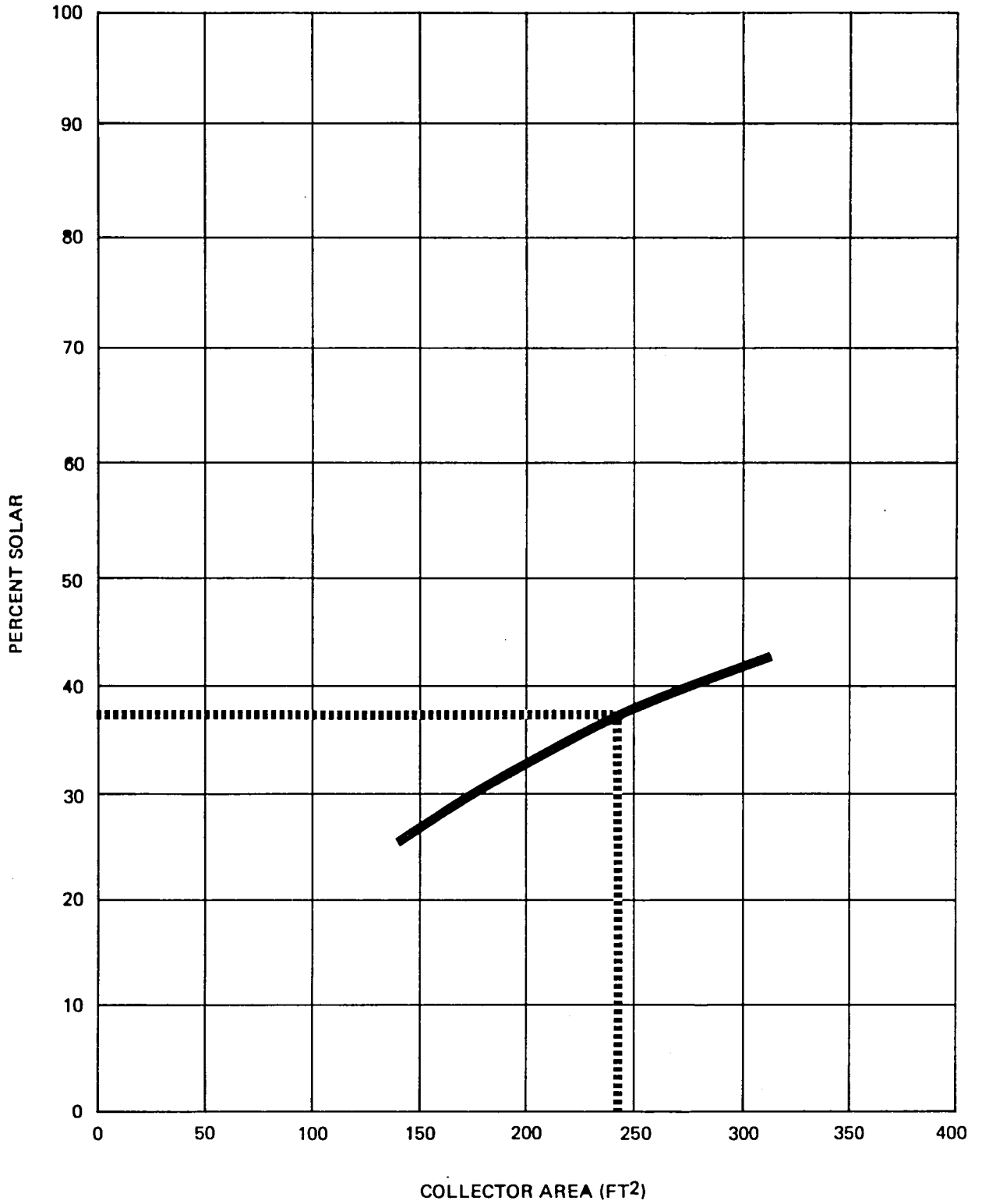

Figure 5.1-1 (d) Solar Fraction vs Collector Area for Solar Energy System at Madison, Wisconsin

WASHINGTON, D. C.
OPTIMAL COLLECTOR AREA = 278 FT²

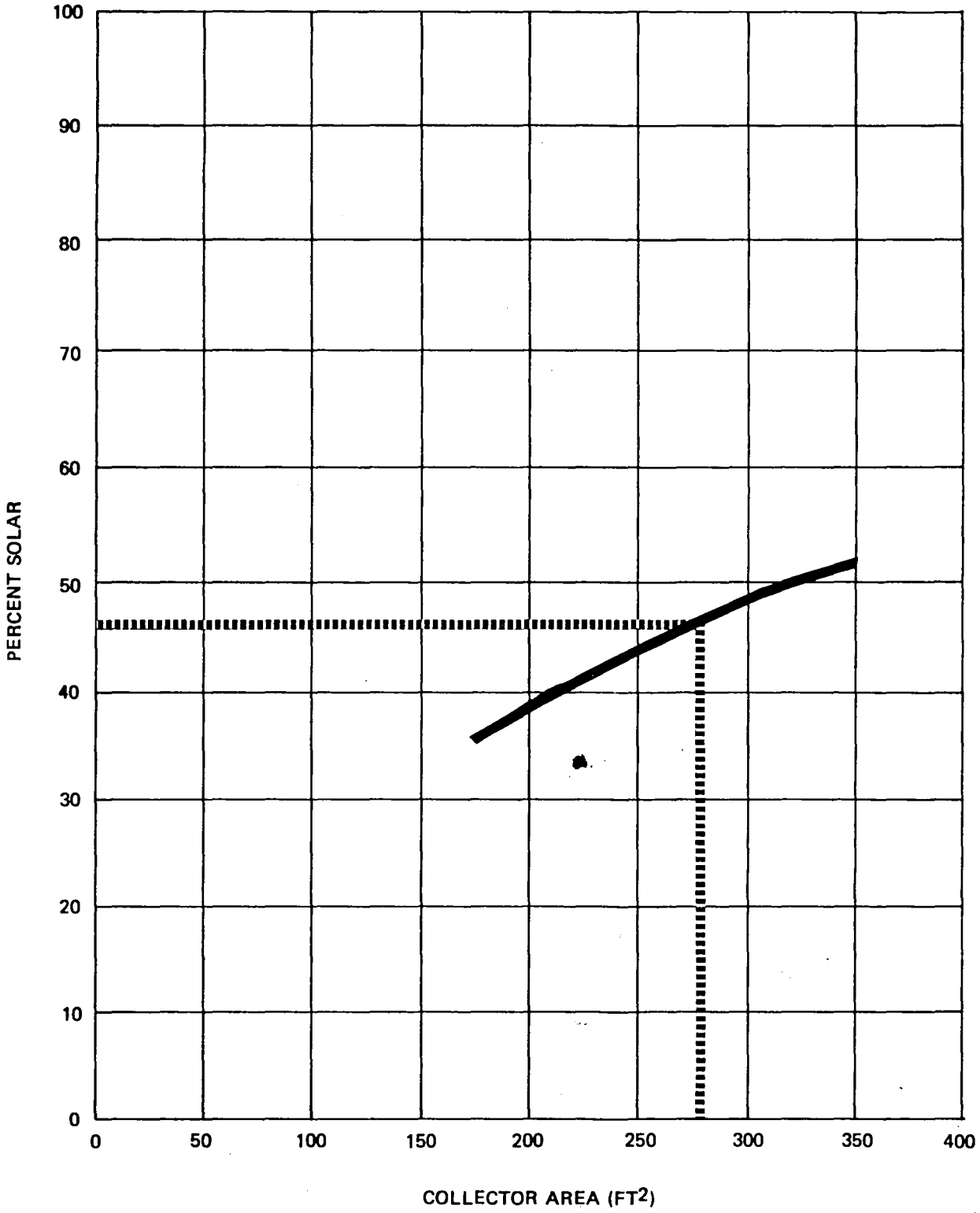

Figure 5.1-1 (e) Solar Fraction vs Collector Area for Solar Energy System at Washington, D. C.

TUNKHANNOCK, PENNSYLVANIA
OPTIMAL COLLECTOR AREA = 243 FT²

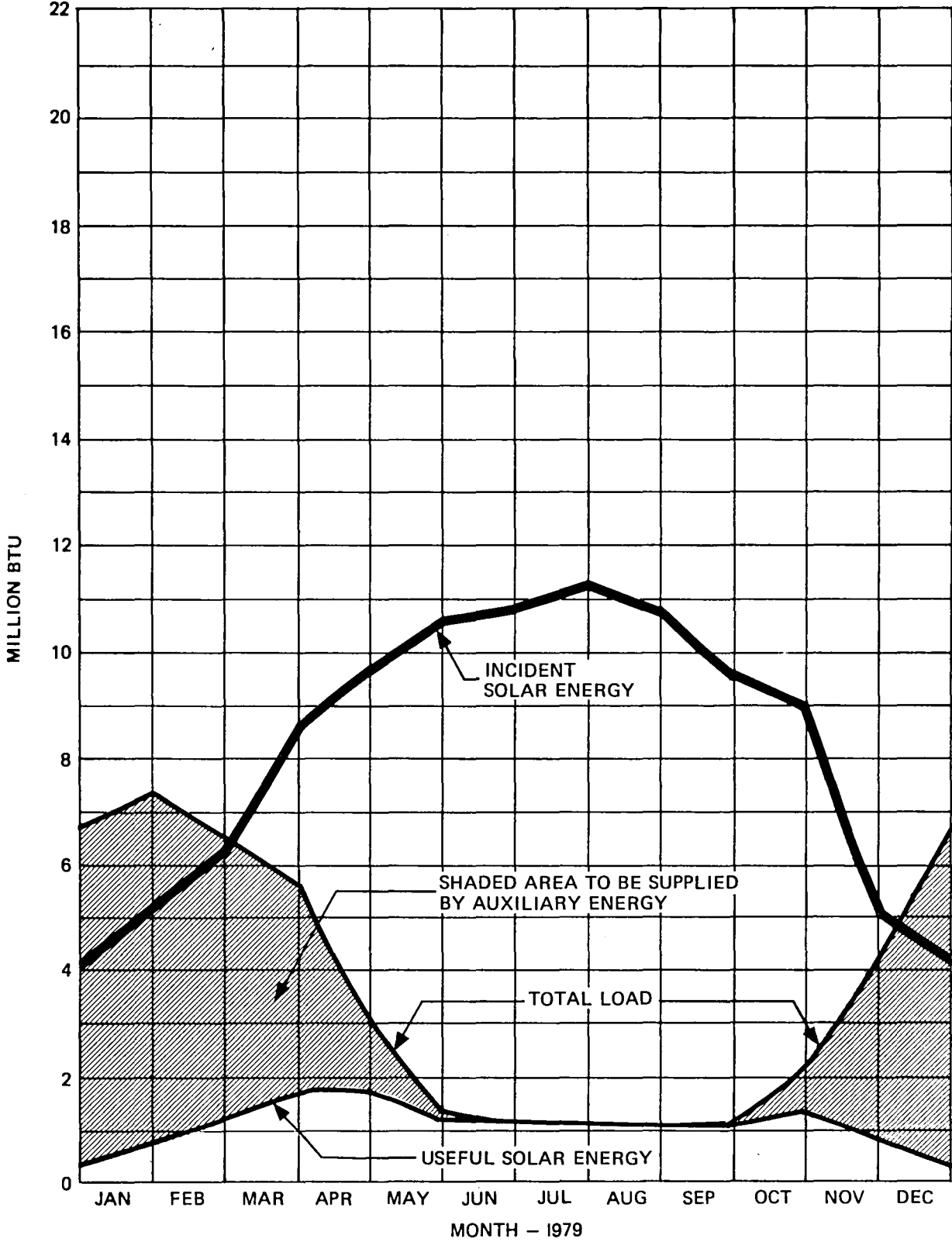

Figure 5.1-2 (a) Thermal Performance of Solar Energy System with Optimized Collector Area for Tunkhannock, Pennsylvania

ALBUQUERQUE, NEW MEXICO
OPTIMAL COLLECTOR AREA = 313 FT²

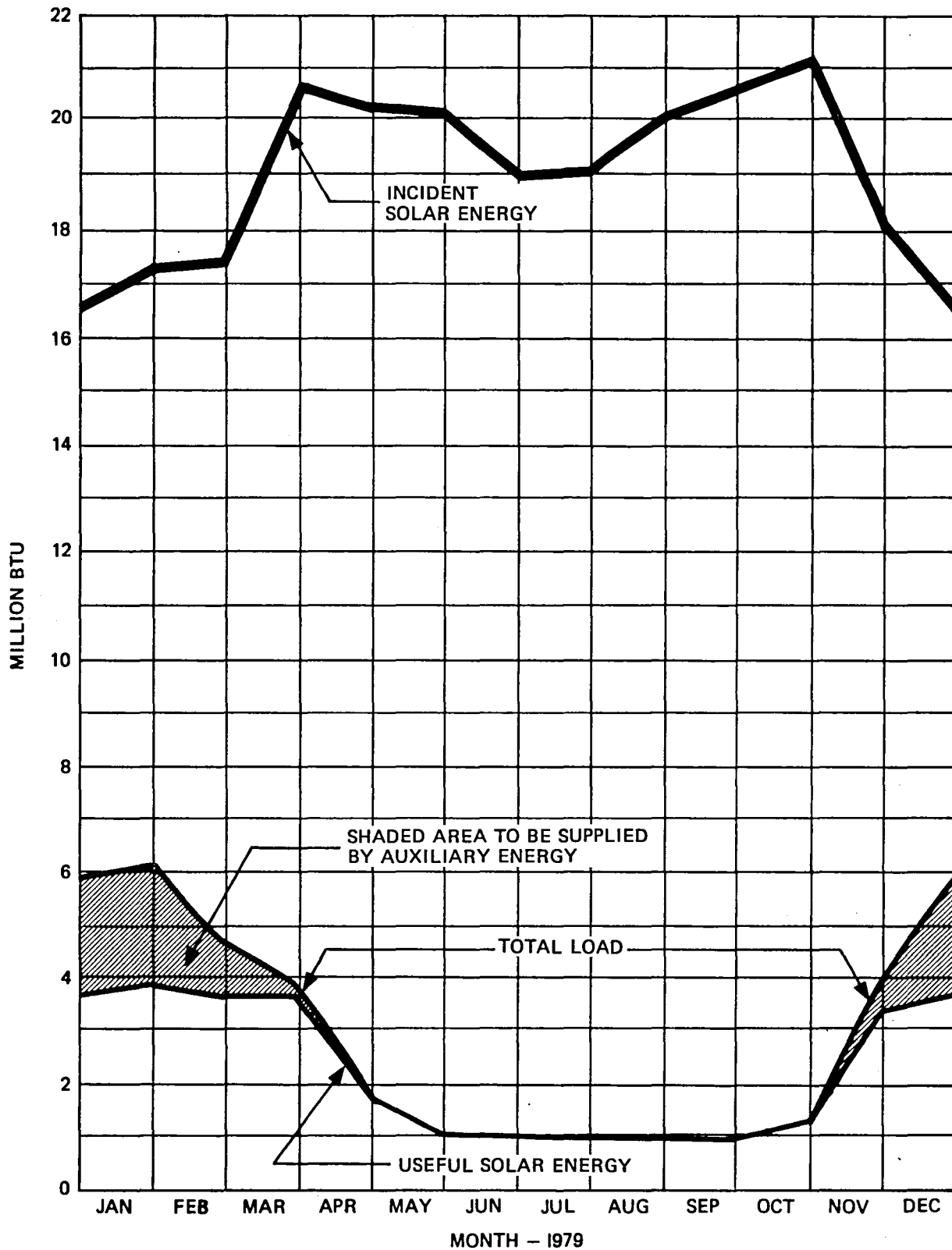

Figure 5.1-2 (b) Thermal Performance of Solar Energy System with Optimized Collector Area for Albuquerque, New Mexico

FORT WORTH, TEXAS
OPTIMAL COLLECTOR AREA = 209 FT²

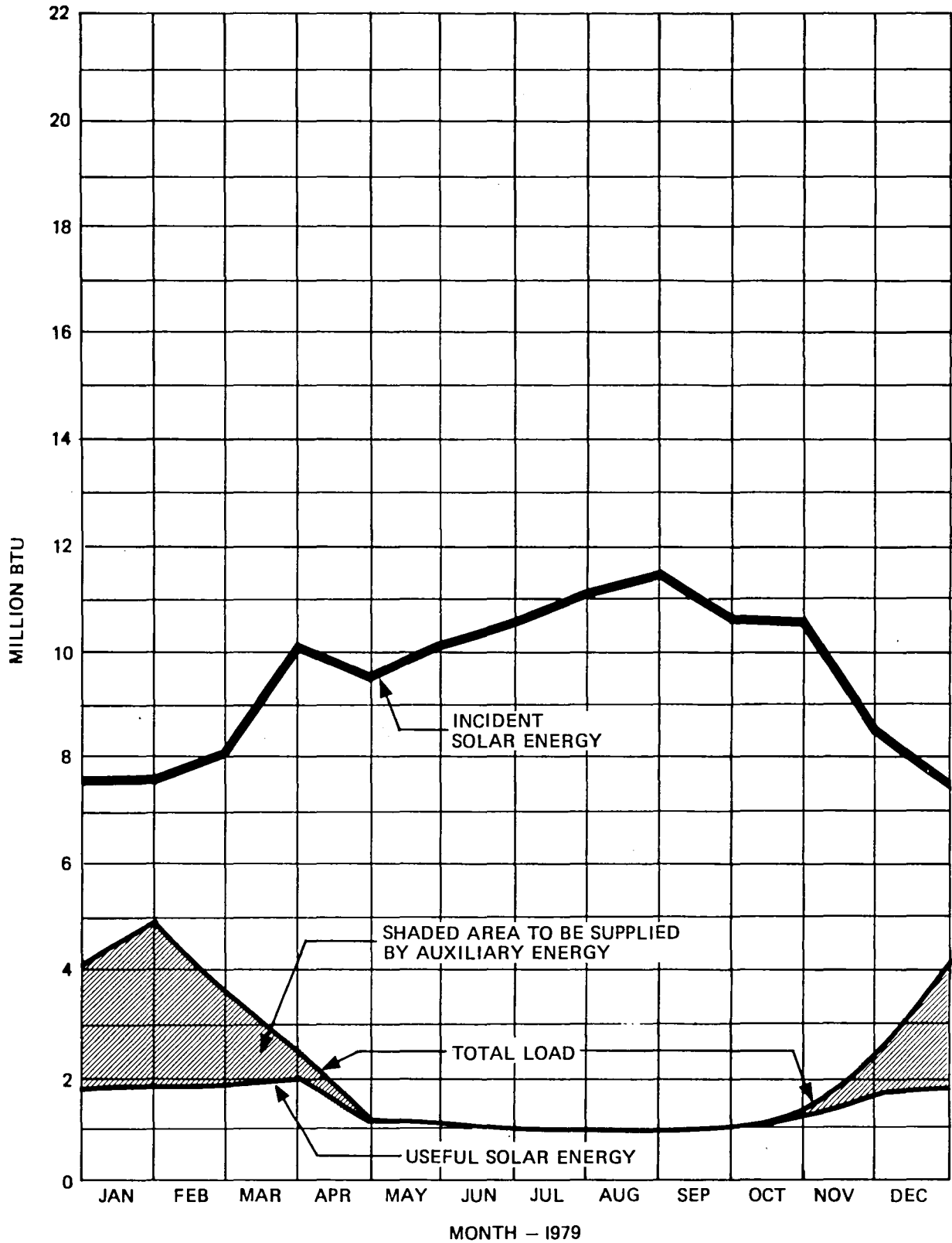

Figure 5.1-2 (c) Thermal Performance of Solar Energy System with Optimized Collector Area for Fort Worth, Texas

MADISON, WISCONSIN
OPTIMAL COLLECTOR AREA = 243 FT²

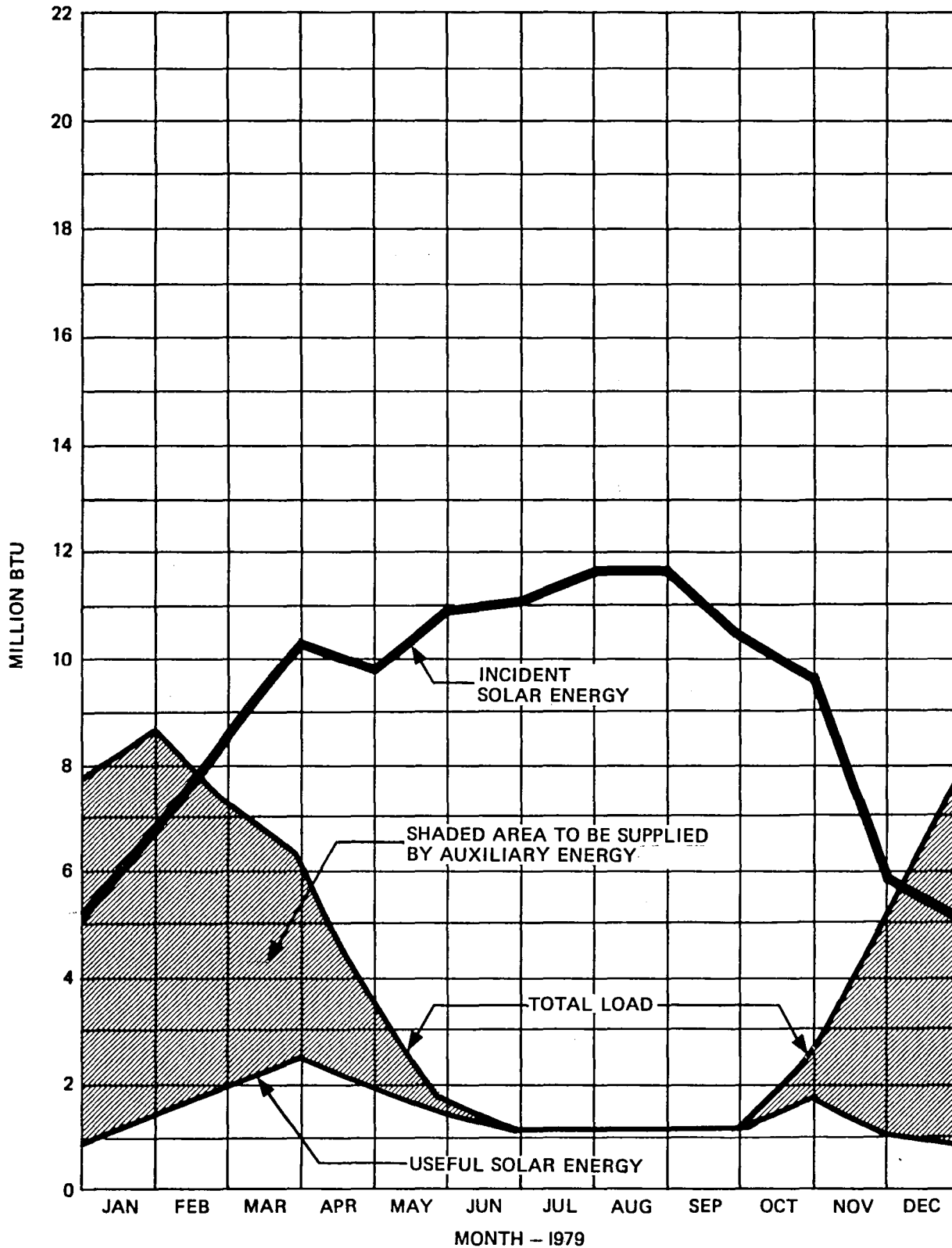

Figure 5.1-2 (d) Thermal Performance of Solar Energy System with Optimized Collector Area for Madison, Wisconsin

WASHINGTON, D.C.
OPTIMAL COLLECTOR AREA = 278 FT²

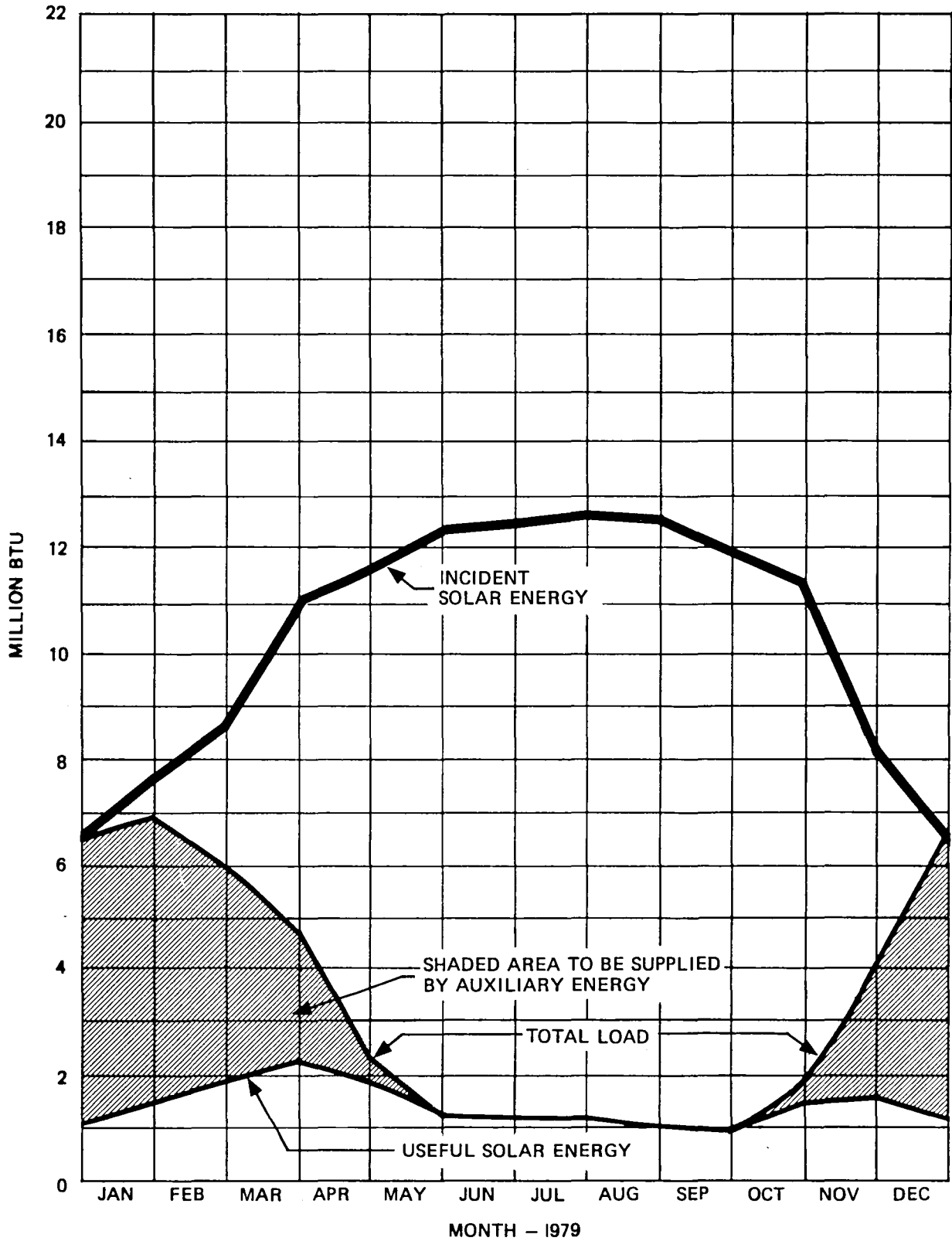

Figure 5.1-2 (e) Thermal Performance of Solar Energy System with Optimized Collector Area for Washington, D.C.

TABLE 5.1-2

f-CHART INPUT VARIABLES

ITEMS	VARIABLE DESCRIPTION	VALUE	UNITS
1	AIR SH+WH = 1, LIQ SH+WH = 2, AIR OR IQ WH ONLY = 3	2	
2	IF 1, WHAT IS (FLOW RATE/COL. AREA)(SPEC. HEAT)?	N/A	BTU/H-°F-FT ²
3	IF 2, WHAT IS (EPSILON)(CMIN)/(UA)?	1.41	
4	COLLECTOR AREA	-	(TABLE 5.1-3)
5	FRPRIME-TAU-ALPHA PRODUCT (NORMAL INCIDENCE)	0.43	
6	FRPRIM-UL PRODUCT	0.52	BTU/H-°F-FT ²
7	INCIDENT ANGLE MODIFIER (ZERO IF NOT AVAIL.)	0	
8	NUMBER OF TRANSPARENT COVERS	1	
9	COLLECTOR SLOPE		(TABLE 5.1-3)
10	AZIMUTH ANGLE (E.G. SOUTH = 0, WEST = 90)		(TABLE 5.1-3)
11	STORAGE CAPACITY	9.59	BTU/°F-FT ²
12	EFFECTIVE BUILDING UA	-	(TABLE 5.1-3)
13	CONSTANT DAILY BLDG. HEAT GENERATION	-	(TABLE 5.1-3)
14	HOT WATER USAGE	66.0	GAL/DAY
15	WATER SET TEMP.(TO VARY BY MONT, INPUT NEG.#)	137.0	°F
16	WATER MAIN TEMP (TO VERY BY MONTH, INPUT NEG. #)	-	(TABLE 5.1-3)
17	CITY CALL NUMBER		
18	THERMAL PRINT OUT BY MONTH = 1, BY YEAR = 2	1	
19	ECONOMIC ANALYSIS ? YES = 1, NO = 2	1	
20	USE OPTMZD. COLLECTOR AREA = 1, SPECFD. AREA = 2	-	
21	SOLAR SYSTEM THERMAL PERFORMANCE DEGRADATION	0	(TABLE 5.1-3)
22	PERIOD OF THE ECONOMIC ANALYSIS	20	YEARS
23	COLLECTOR AREA DEPENDENT SYSTEM COSTS	10.51	\$/FT ²
24	CONSTANT SOLAR COSTS	2678.00	\$
25	DOWN PAYMENT (% OF ORIGINAL INVESTMENT)	20	%
26	ANNUAL INTEREST RATE ON MORTGAGE	13.5	%
27	TERM OF MORTGAGE	20	YEARS
28	ANNUAL NOMINAL (MARKET) DISCOUNT RATE	8.5	%
29	EXTRA INSUR./MAINT. IN YEAR 1 (% OF ORIG. INV.)	0.5	%
30	ANNUAL % INCREASE IN ABOVE EXPENSE	10.0	%
31	PRESENT COST OF SOLAR BACKUP FUEL (BF)	-	(TAB:E 5.1-3)
32	BF RISE: %/YR = 1, SEQUENCE OF VALUES = 2	1	
33	IF 1, WHAT IS THE ANNUAL RATE OF BF RISE	12.5	%
34	PRESENT COST OF CONVENTIONAL FUEL (CF 1	Note 1	
35	CF RISE: %/YR = 1, SEQUENCE OF VALUES = 2	1	
36	IF 1, WHAT IS THE ANNUAL RATE OF DV RISE	12.5	%
37	ECONOMIC PRINT OUT BY YEAR = 1, CUMULATIVE = 2	1	
38	EFFECTIVE FEDERAL - STATE INCOME TAX RATE	30	%
39	TRUE PROP. TAX RATE PER \$ OF ORIGINAL INVEST.	0	%

TABLE 5.1-2

f-CHART INPUT VARIABLES (Continued)

ITEMS	VARIABLE DESCRIPTION	VALUE	UNITS
40	ANNUAL % INCREASE IN PROPERTY TAX RATE		N/A
41	CAL. RT. OF RETURN ON SOLAR INVTMT? YES = 1, NO = 2	-	
42	RESALE VALUE (% OF ORIGINAL INVESTMENT)	0	%
43	INCOME PRODUCING BUILDING? YES = 1, NO = 2	2	
44	DPRC.: STR.LN=1,DC.BAL.=2,SM-YR-DGT=3,NONE=4	2	
45	IF 2, WHAT % OF STR.LN DPRC.RT IS DESIRED?	150	%
46	USEFUL LIFE FOR DEPREC. PURPOSES	20	YEARS
47	ECONOMIC COEFFICIENT OF PERFORMANCE OF BACKUP HEATING SYSTEM .	-	(TABLE 5.1-3)
48	ECONOMIC COEFFICIENT OF PERFORMANCE OF BACKUP WATER HEATER . .	1	

NOTE: 1. The values of Collector Area Dependent System Costs and Constant Solar Costs depend on system size (because of the Federal Tax Credit). These costs are listed in Table 5.2-1. The Area Dependent Cost listed in Table 5.2-1 must be divided by the optimal area to obtain the value for Collector Area Dependent System Costs.

NOTE: 2. Since the backup for the solar system is assumed to be the same type of system as would conventionally be used without a solar system, backup fuel costs and conventional costs per million Btu are equal.

TABLE 5.1-3

SOLAR SYSTEM TECHNICAL PARAMETERS FOR F-CHART PROGRAM

VARIABLE DESCRIPTION	UNITS	LOCATION				
		TUNKHANNOCK	ALBUQUERQUE	FORT WORTH	MADISON	WASHINGTON
COLLECTOR AREA- OPTIMAL	FT ²	209	313	209	243	278
COLLECTOR SLOPE	DEGREES	45	45	43	53	49
AZIMUTH ANGLE	DEGREES	15	0	0	0	0
EFFECTIVE BLDG UA	BTU/°F-DAY	6000	6749	7406	5523	6500
CONSTANT DAILY BLDG HEAT GENERATION	BTU/DAY	42000	42000	42000	42000	42000
SUPPLY WATER TEMPERATURE	°F	SEE TABLE C-1 FOR MONTHLY VALUES				
SYSTEM THERMAL PERF. DEGRADATION	%/YR	0	0	0	0	0
PRESENT COST OF SOLAR BACKUP FUEL ⁽¹⁾	\$/MMBTU	6.79	7.41	7.03	6.54	7.42
REFERENCE COST OF ELECTRICITY ⁽²⁾	\$/MMBTU	14.80	20.39	13.01	12.21	19.78
ECONOMIC COP OF HEATING SYSTEM	-	1.31	1.65	1.11	1.12	1.60

- NOTES: 1. The solar back up for this system is fuel oil. See Appendix D for rate computation.
2. An effective rate is computed for each location based on 1000 kWh usage. This effective rate includes all charges specified in the rate schedules in Appendix D.
3. See Appendix A for an explanation of the Economic COP and the method of computation.

5.2 Economic Results

An essential factor in maximizing the life cycle savings of a solar energy system, or conversely, of minimizing life cycle costs is the economic optimization of the collector area based on equipment and fuel (conventional energy) costs and the capability of the solar system to replace significant quantities of conventional energy with solar energy. The replacement capability is directly dependent on the environmental conditions at the installation site, i.e. available solar energy.

The graphs of Figures 5.2-1 (a) - (e) show the relationship of the factors comprising life cycle costs - equipment costs and fuel costs - as a function of collector area. Both costs are presented in terms of present value, i.e. baselined to today's dollars. It can be readily seen that as collector area increases, solar equipment costs increase proportionately. Also, as collector area increases the fuel costs decrease, although not as a straight line function. At some given collector area, the sum of these two costs is a minimum, as shown by the life cycle cost (LCC) curve. This minimum defines the optimal collector area for the given installation site.

The solar equipment costs discussed in the preceding paragraphs include the principal and interest paid on a 13.5 percent, 20 year mortgage, the income tax deduction for interest for an owner in the 30 percent bracket and the insurance and maintenance costs estimated at 0.5 percent of the initial costs. The fuel cost is that which is required by the conventional backup system and includes the effects of the f-Chart solar system model.

The life cycle costs are not to be confused with life cycle savings. Life cycle savings is the difference between the life cycle costs of

fuel for a conventional system and the life cycle cost of owning, operating and maintaining a solar energy system.

The LCC is clearly defined at the optimum collector area for all analysis sites as shown in Figures 5.2-1 (a) - (b). It should be noted that the "Solar System Life Cycle Cost" is significantly lower for the Fort Worth, Texas and the Albuquerque, New Mexico sites respectively.

A summary of the costs and savings for the conventional system and the solar energy system is shown in Table 5.2-1 in terms of today's dollars expended over the analysis period. It should be recalled that the equipment costs shown do not include the cost of the conventional system since this system must be provided with or without the solar energy system. The equipment costs include only the additional hardware that must be provided for the solar energy system. This includes the following:

- Collectors and mounting hardware
- Piping and duct work (including valves and dampers)
- Heat exchanger(s)
- Storage unit(s)
- Control system

The best estimates of equipment costs for solar energy systems indicate that costs fall into two categories; (1) costs dependent on collector area and, (2) costs independent of collector area, or constant costs. This is the case, especially for residential systems, because regardless of the exact collector area used, certain items of equipment must be provided and the costs of hardware and labor for installation seem to be relatively constant. However, the cost of collectors, and certain incremental costs, are dependent on the size of the collectors used. These costs are shown in Table 5.2-1 for each of the five analysis sites and the total cost for the system is the sum of the constant cost and the area dependent cost multiplied by the collector area.

The initial cost of the system in this analysis should be adjusted for the federal tax credit (and any other tax credit allowed by the state or local governments) by the methods discussed in Section 4.2. These adjusted costs are shown in parentheses under "Initial Cost of System" in Table 5.2-1 and are used in computing the "Present Worth of Total Solar Costs."

Some conventional energy must be expended with or without the solar energy system because, in most cases, the solar energy system will replace only a portion of the total energy required to support the load. Savings are possible with the solar system only because the total costs with the solar system are less than the costs of conventional energy. Consequently, the fuel costs over the analysis period (20 years) are shown in Table 5.2-1 with and without the solar system.

It is assumed in this analysis that the solar system would be financed through a 20 year loan at an interest rate of 13.5 percent. Property taxes are assumed to be zero, but this may not be universally true. Insurance on the value of the solar energy system and maintenance costs are assumed to be 0.5 percent per year of the initial costs. Since interest paid on a loan is tax deductible for federal taxes, and in most cases for state taxes, at different rates according to the income tax bracket of the borrower, a 30 percent combined federal-state tax bracket was assumed. The value of all these costs based on the assumptions of this analysis is shown as the "Present Worth of Other Solar Costs" in Table 5.2-1. Combined with the costs for fuel with the solar system, the value is the "Present Worth of Total Solar Costs."

Since only incremental equipment and associated costs are included in the analysis, the present worth of total costs for the conventional system without solar are simply the cost of fuel without solar. Then the "Present

Worth of Cumulative Savings" is the difference between the "Present Worth of Total Costs Without Solar" and the "Present Worth of the Total Costs With Solar". These values for each of the five analysis sites are listed in Table 5.2-1.

Finally, two economic performance parameters called "Year of Positive Savings" and the "Year of Payback" are shown in Table 5.2-1. As previously discussed the year of positive savings is the year after purchase in which the solar system first becomes profitable, i.e., the annual conventional fuel bill without solar exceeds the sum of the annual fuel bill with solar and the annual costs for the solar system. The year of payback is the year after purchase when the compounded net savings equals the initial cost for the solar system. Savings are compounded at the discount rate throughout the analysis period. The factors that determine years until positive savings are shown in Figures 5.2.2 (a) - (e) for each analysis site. The factors that determine the years until payback are shown in Figures 5.2-3 (a) - (e) for each analysis site. The year corresponding to the intersection of the "Mortgage Principle Remaining" curve and the "Compounded Solar Savings" curve is the year that the savings are sufficient to pay off the mortgage balance.

Figure 5.2-2 (a) - (e) show that all sites provide a positive savings in a maximum of eleven years (Tunkhannock, Pennsylvania) with Albuquerque, New Mexico at a minimum of four years. Conventional energy cost greatly influence the positive savings associated with each site.

Figures 5.2.3 (a) - (e) reveal that only two sites, Albuquerque, New Mexico and Washington, D.C., provide a payback within a reasonable investment period of twenty years. As shown in the payback period is sixteen years (actual fifteen year and ten months) and twenty years, respectively.

Table 5.2-1 provides a tabulation of the costs and savings for each analysis site over a twenty year analysis period.

TUNKHANNOCK, PENNSYLVANIA
OPTIMAL COLLECTOR AREA = 243 FT²

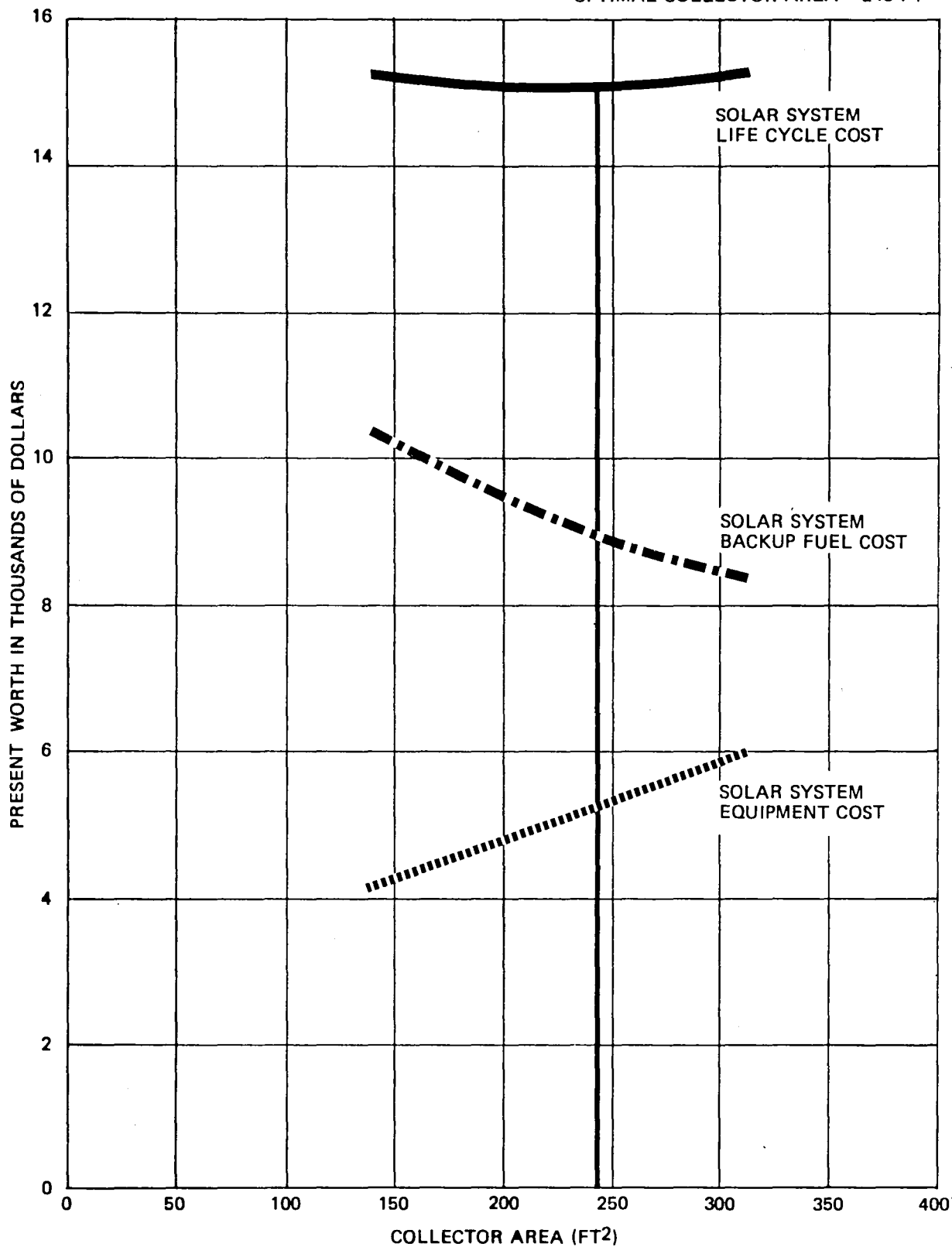

Figure 5.2-1 (a) Optimization of Collector Area for Tunkhannock, Pennsylvania

ALBUQUERQUE, NEW MEXICO
OPTIMAL COLLECTOR AREA = 313 FT²

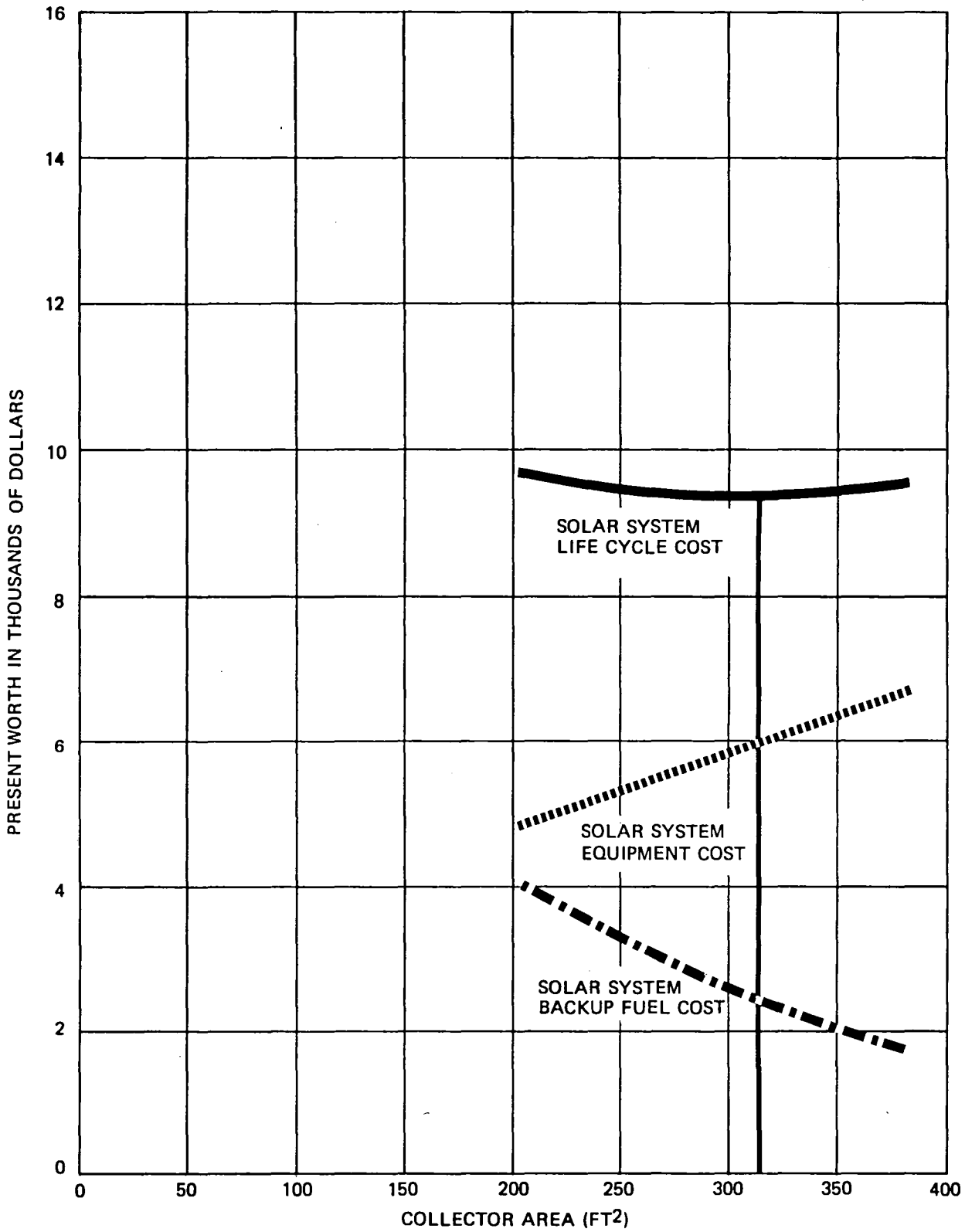

Figure 5.2-1 (b) Optimization of Collector Area for Albuquerque, New Mexico

FORT WORTH, TEXAS
OPTIMAL COLLECTOR AREA = 209 FT²

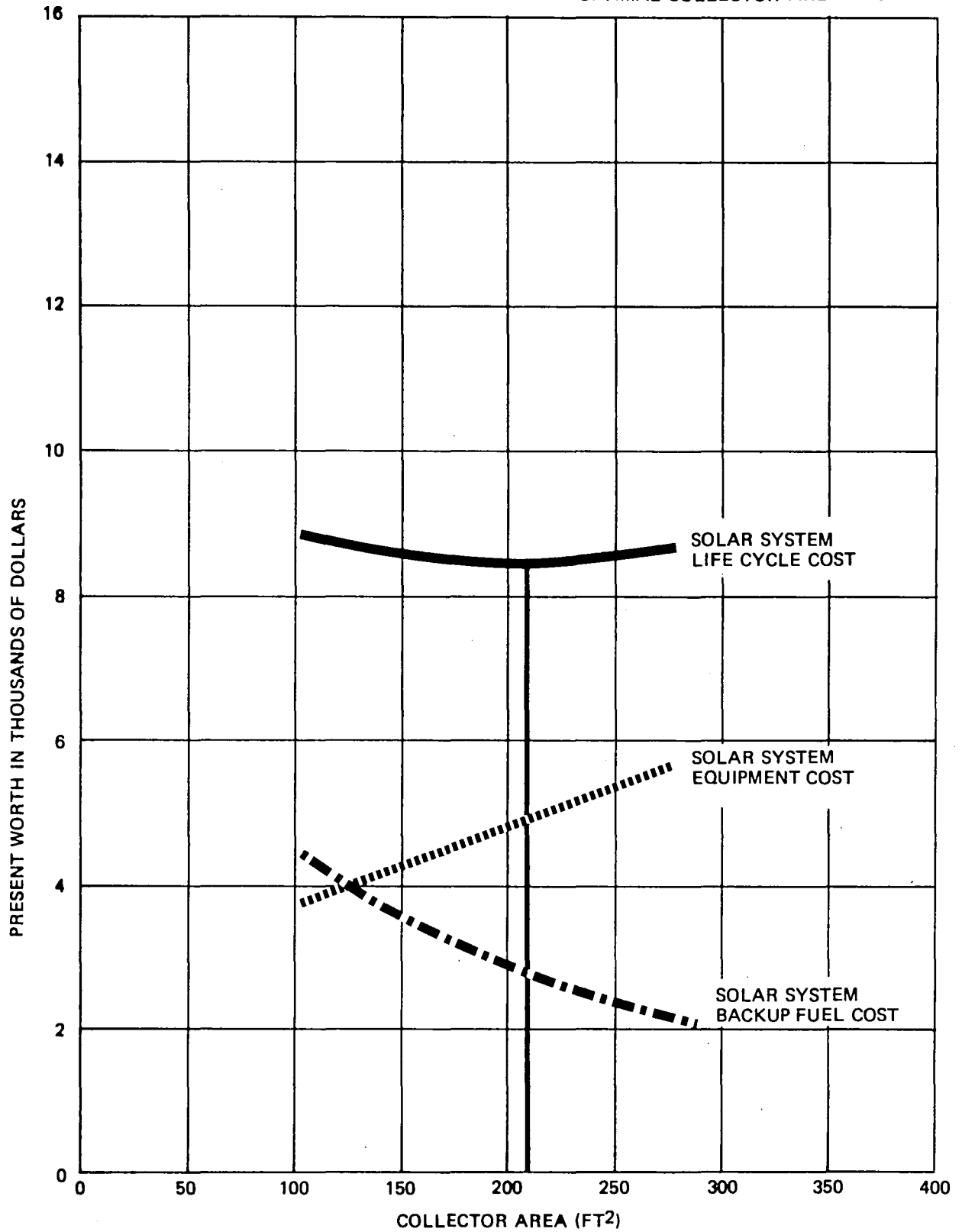

Figure 5.2-1 (c) Optimization of Collector Area for Fort Worth, Texas

MADISON, WISCONSIN
OPTIMAL COLLECTOR AREA = 243FT²

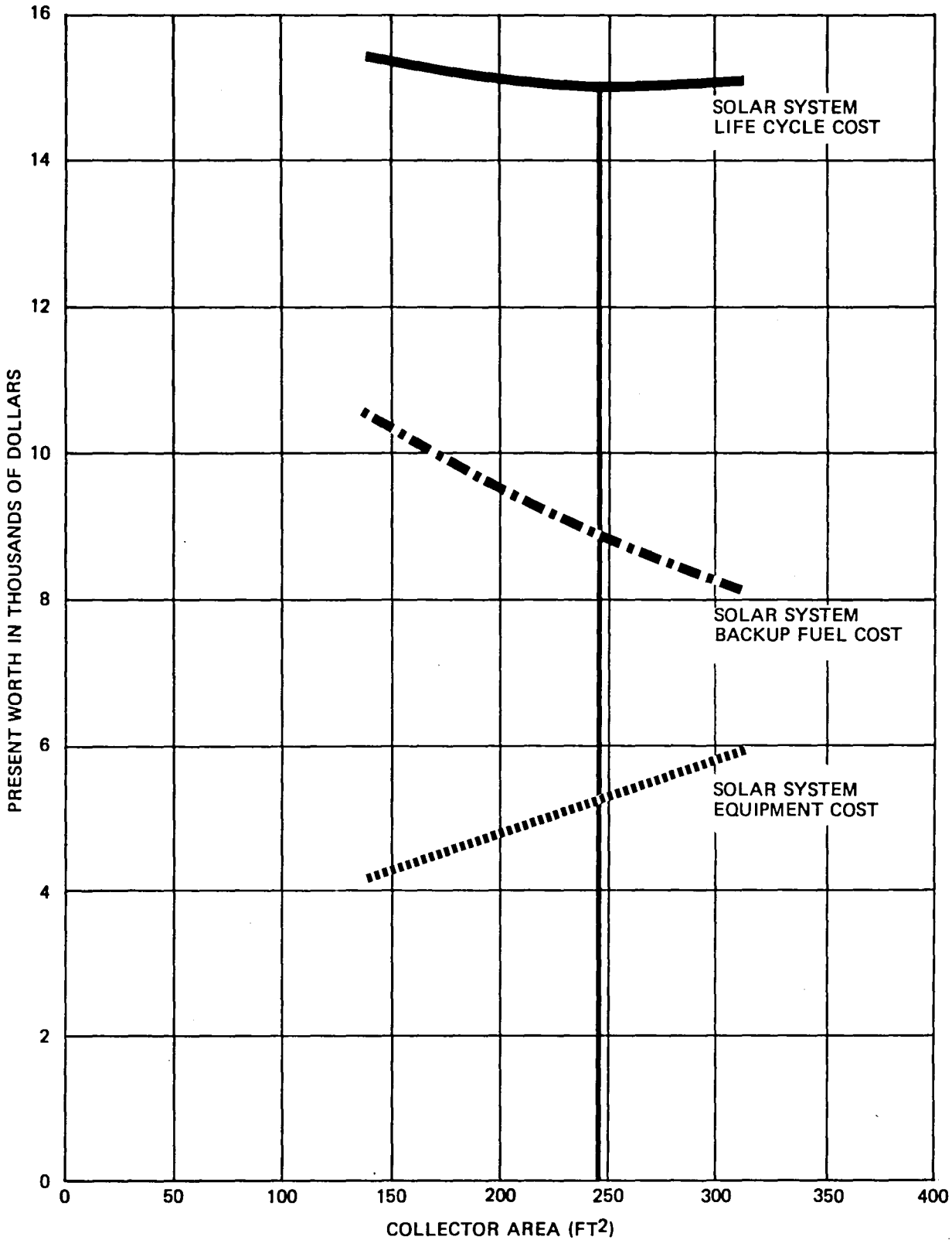

Figure 5.2-1 (d) Optimization of Collector Area for Madison, Wisconsin

WASHINGTON, D. C.
OPTIMAL COLLECTOR AREA = 278 FT²

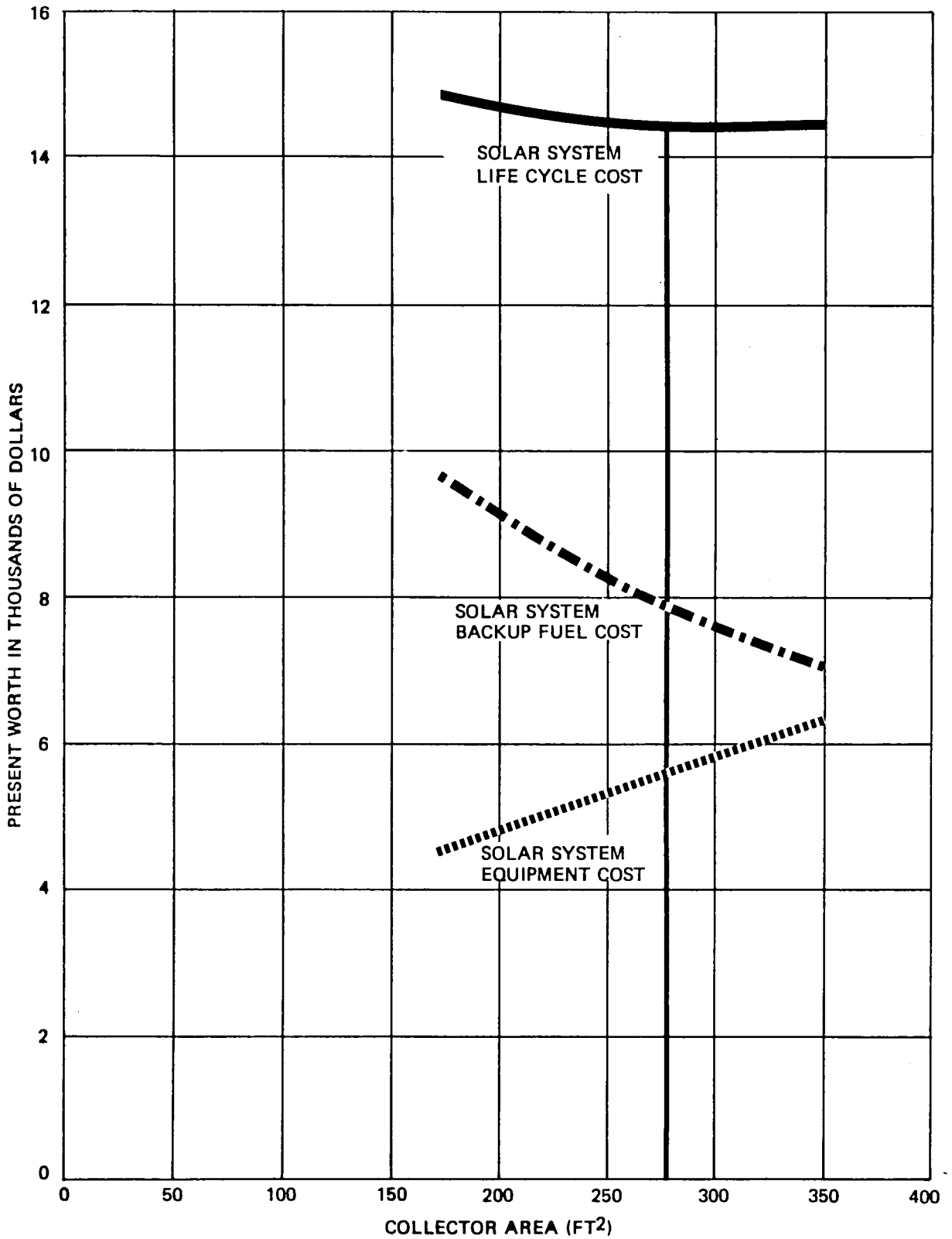

Figure 5.2-1 (e) Optimization of Collector Area for Washington, D.C.

SUMMARY TABLE

TABLE 5.2-1

COSTS AND SAVINGS OVER 20 YEAR ANALYSIS PERIOD IN DOLLARS (1980)

SITE	INITIAL COST OF SYSTEM ¹			PRESENT WORTH OF FUEL COSTS		PRESENT WORTH OF OTHER SOLAR COSTS	PRESENT WORTH OF TOTAL SOLAR COSTS	PRESENT WORTH OF TOTAL COSTS W/O SOLAR	PRESENT WORTH OF CUMULATIVE SAVINGS	YEAR OF POSITIVE SAVINGS	YEAR OF PAYBACK
	CONSTANT	AREA DEPENDENT	TOTAL	WITH SOLAR	W/O SOLAR						
TUNKHANNOCK	4464 (2678)	4257 (2554)	8721 (5232)	8981	13845	6114	15095	13845	-1250	11	>20
ALBUQUERQUE	4464 (2678)	5484 (3290)	9948 (5968)	2418	13465	6962	9380	13465	4085	4	16
FORT WORTH	4464 (2678)	3662 (2197)	8126 (4875)	2790	8205	5679	8469	8205	-264	9	>20
MADISON	4464 (2618)	4257 (2554)	8721 (5232)	8954	14323	6110	15064	14323	-741	10	>20
WASHINGTON	4464 (2678)	4871 (2922)	9335 (5600)	7865	15569	6538	14403	15569	1165	7	20

NOTE:

1. Values in parentheses are adjusted for the Federal tax credit by the method detailed in Section 4.2.

TUNKHANNOCK, PENNSYLVANIA
OPTIMAL COLLECTOR AREA = 243 FT²

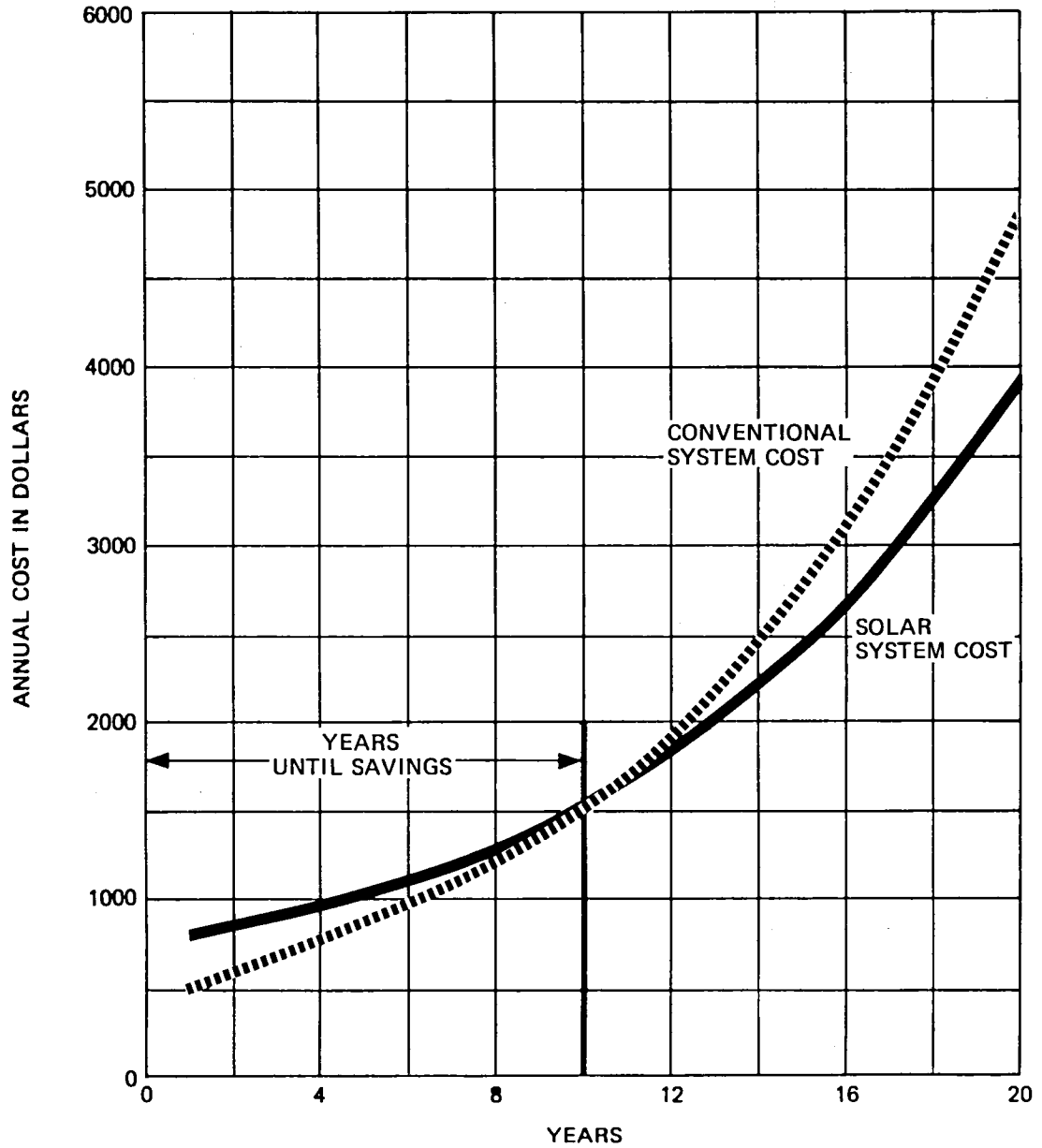

Figure 5.2-2 (a) Annual Expenses for Solar System and Conventional System at Tunkhannock, Pennsylvania

ALBUQUERQUE, NEW MEXICO
OPTIMAL COLLECTOR AREA = 313 FT²

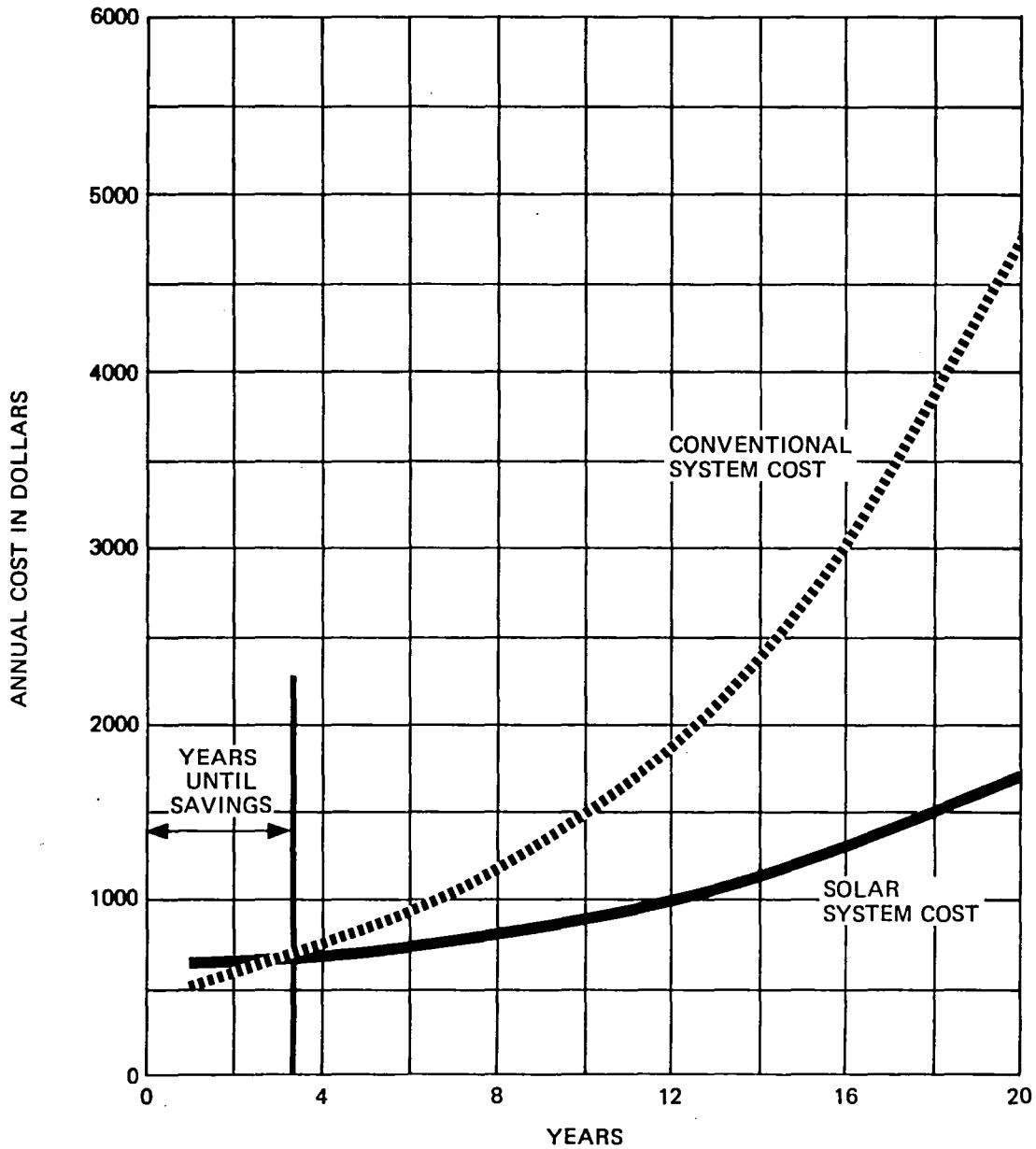

Figure 5.2-2 (b) Annual Expenses for Solar System and Conventional System at Albuquerque, New Mexico

FORT WORTH, TEXAS
OPTIMAL COLLECTOR AREA = 209 FT²

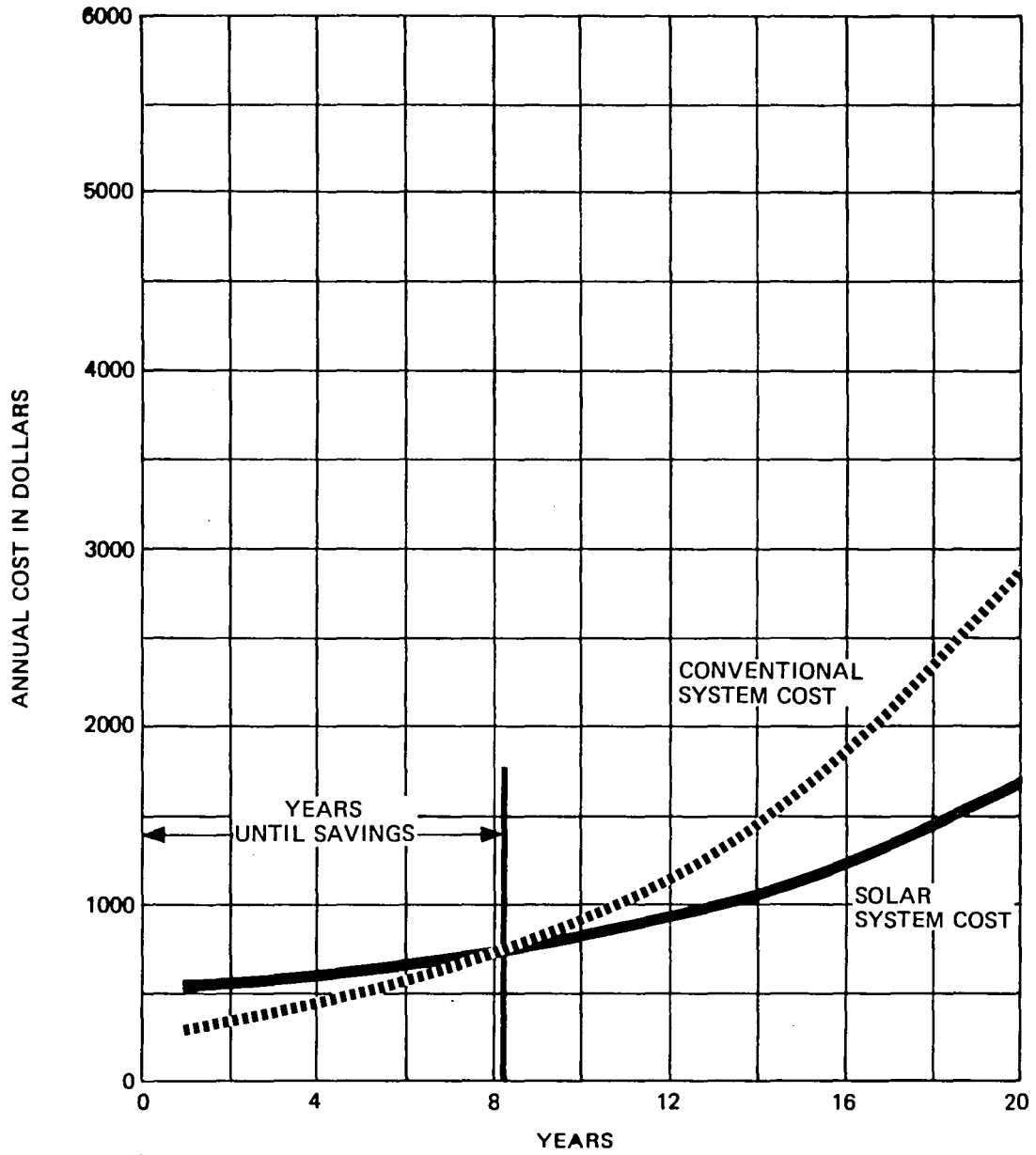

Figure 5.2-2 (c) Annual Expenses for Solar System and Conventional System at Fort Worth, Texas

MADISON, WISCONSIN
OPTIMAL COLLECTOR AREA = 243 FT²

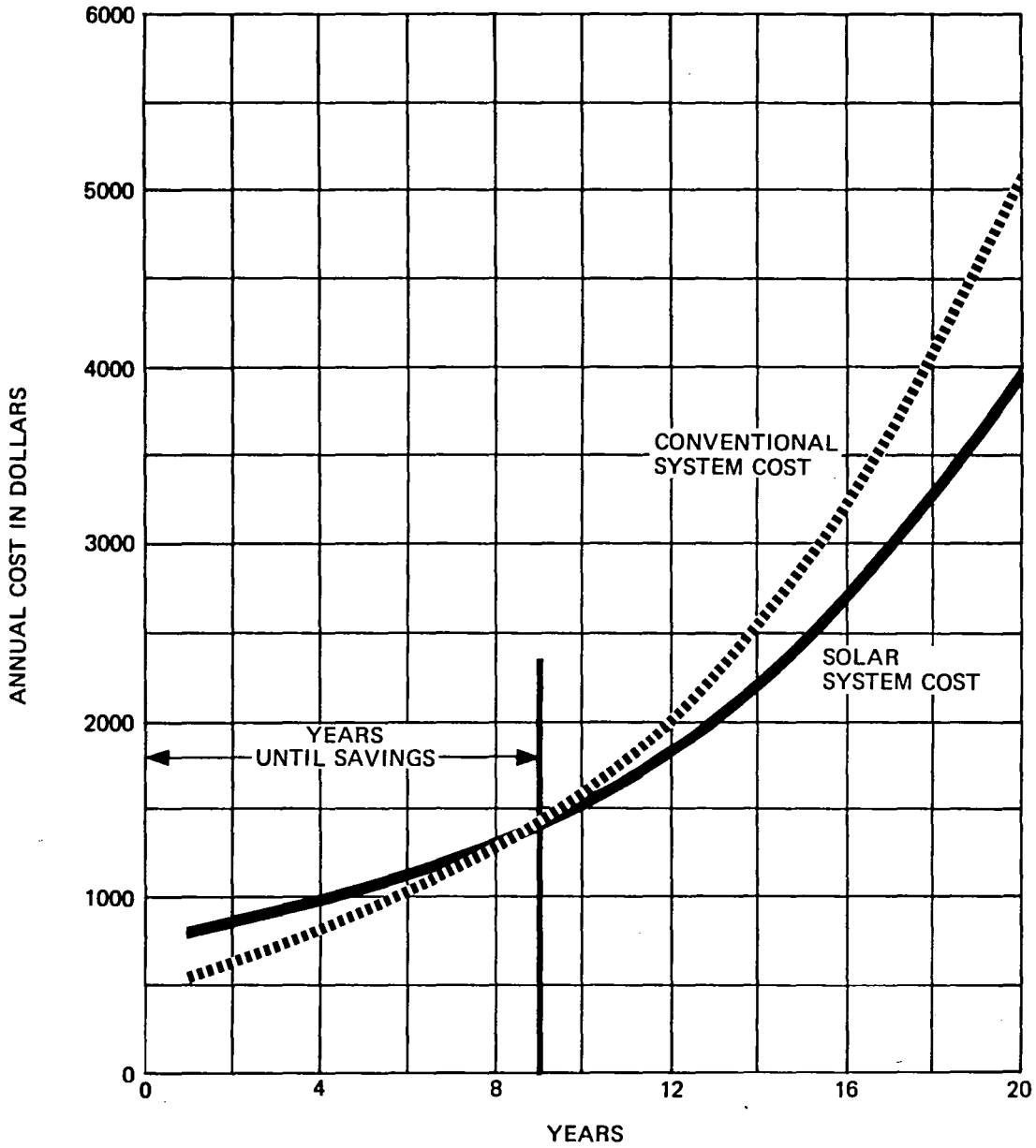

Figure 5.2-2 (d) Annual Expenses for Solar System and Conventional System at Madison, Wisconsin

WASHINGTON, D.C.
OPTIMAL COLLECTOR AREA = 278 FT²

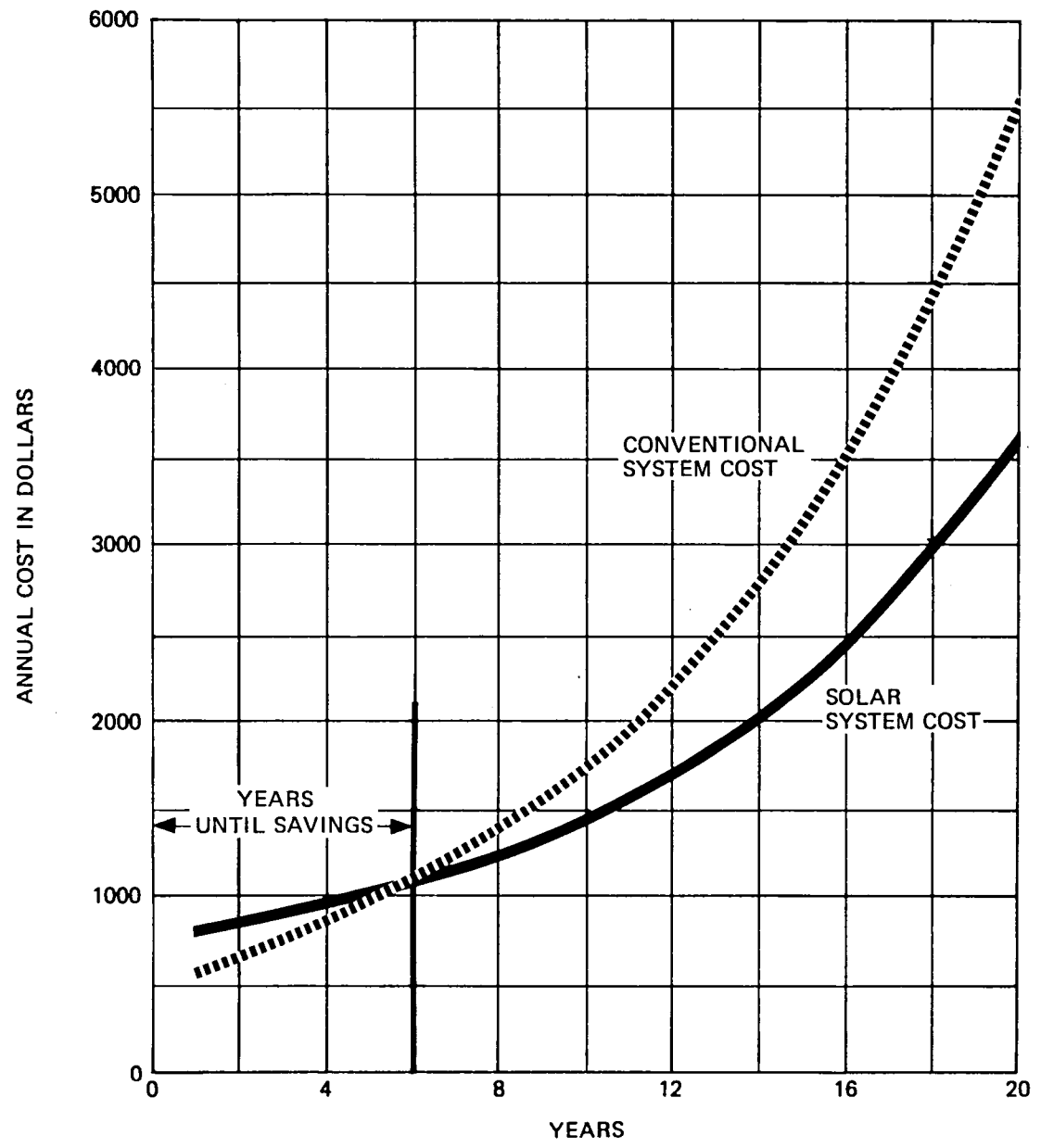

Figure 5.2-2 (e) Annual Expenses for Solar System and Conventional System at Washington, D.C.

TUNKHANNOCK, PENNSYLVANIA
OPTIMAL COLLECTOR AREA = 243 FT²

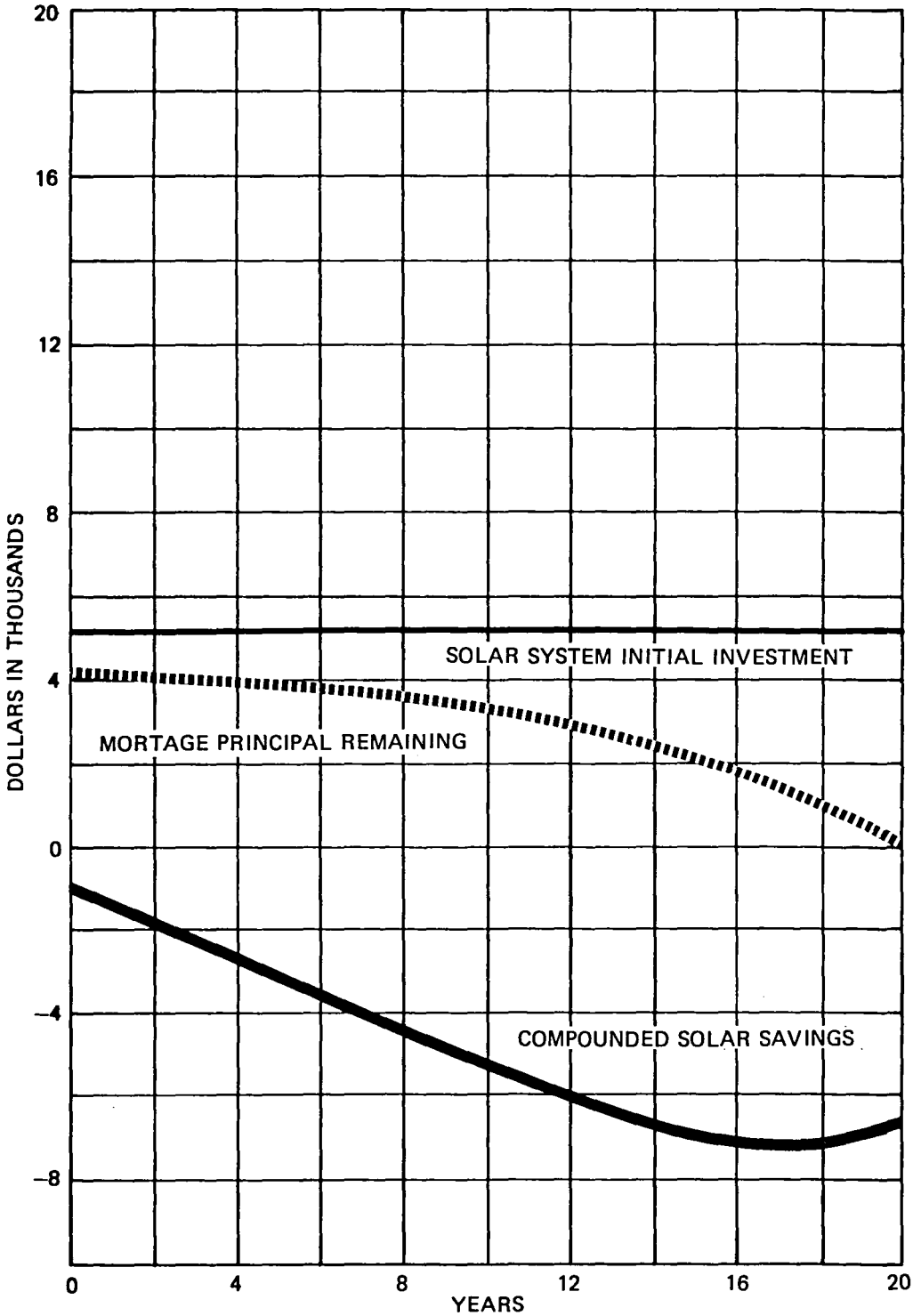

Figure 5.2-3 (a) Payback for Solar Energy System for Tunkhannock, Pennsylvania

ALBUQUERQUE, NEW MEXICO
OPTIMAL COLLECTOR AREA = 313 FT²

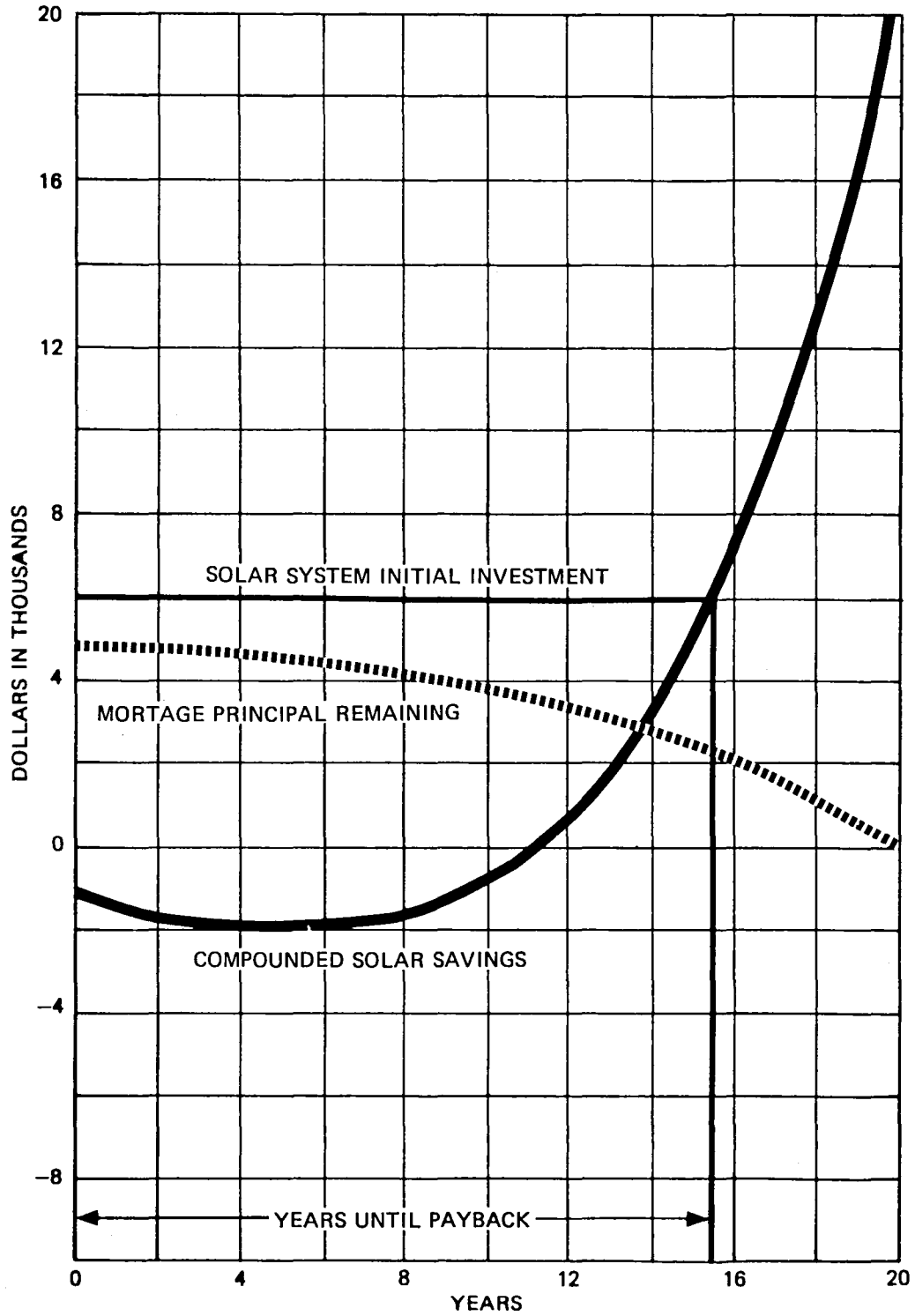

Figure 5.2-3 (b) Payback for Solar Energy System for Albuquerque, New Mexico

FORT WORTH, TEXAS
OPTIMAL COLLECTOR AREA = 209 FT²

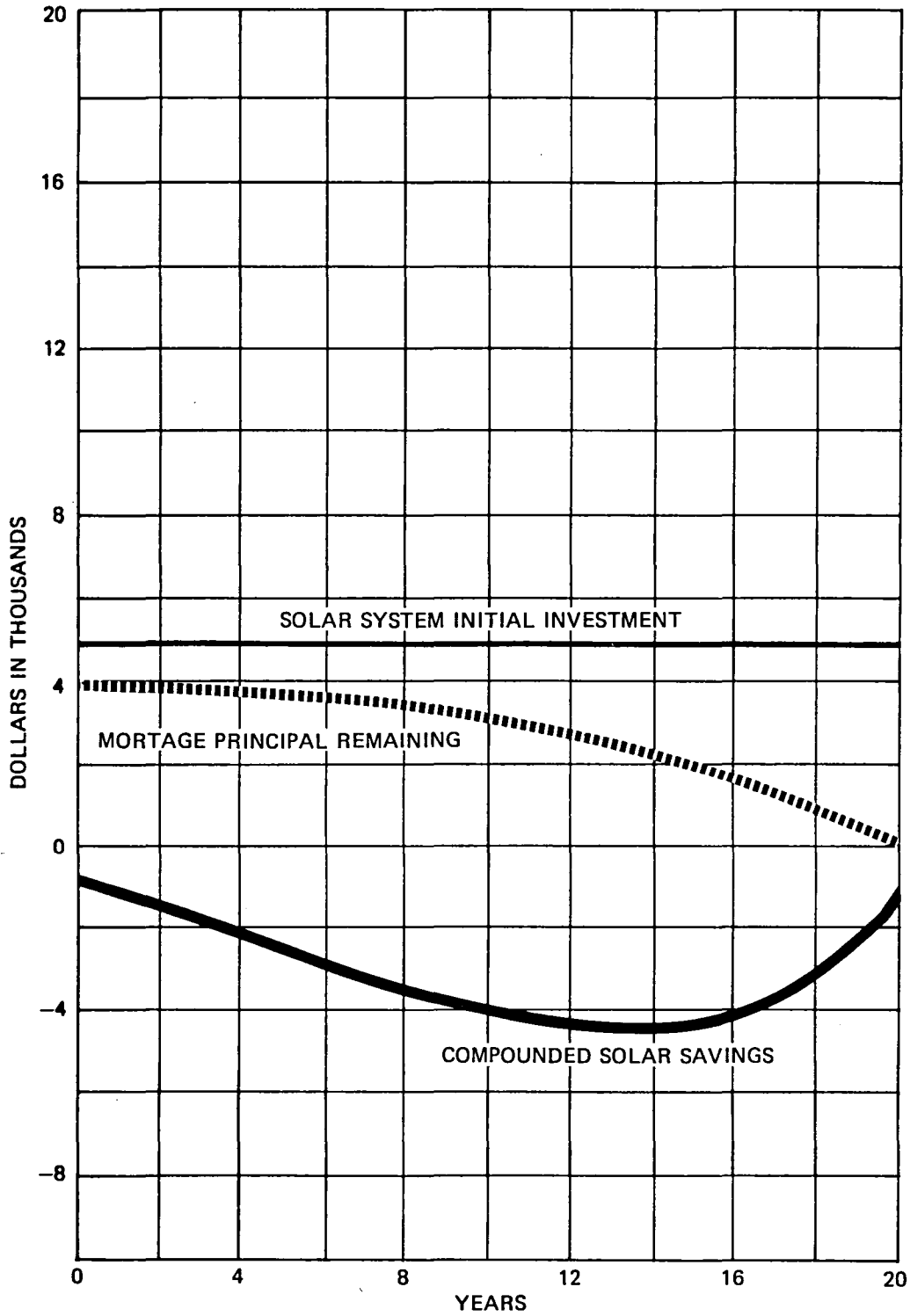

Figure 5.2-3 (c) Payback for Solar Energy System for Fort Worth, Texas

MADISON, WISCONSIN
OPTIMAL COLLECTOR AREA = 243 FT²

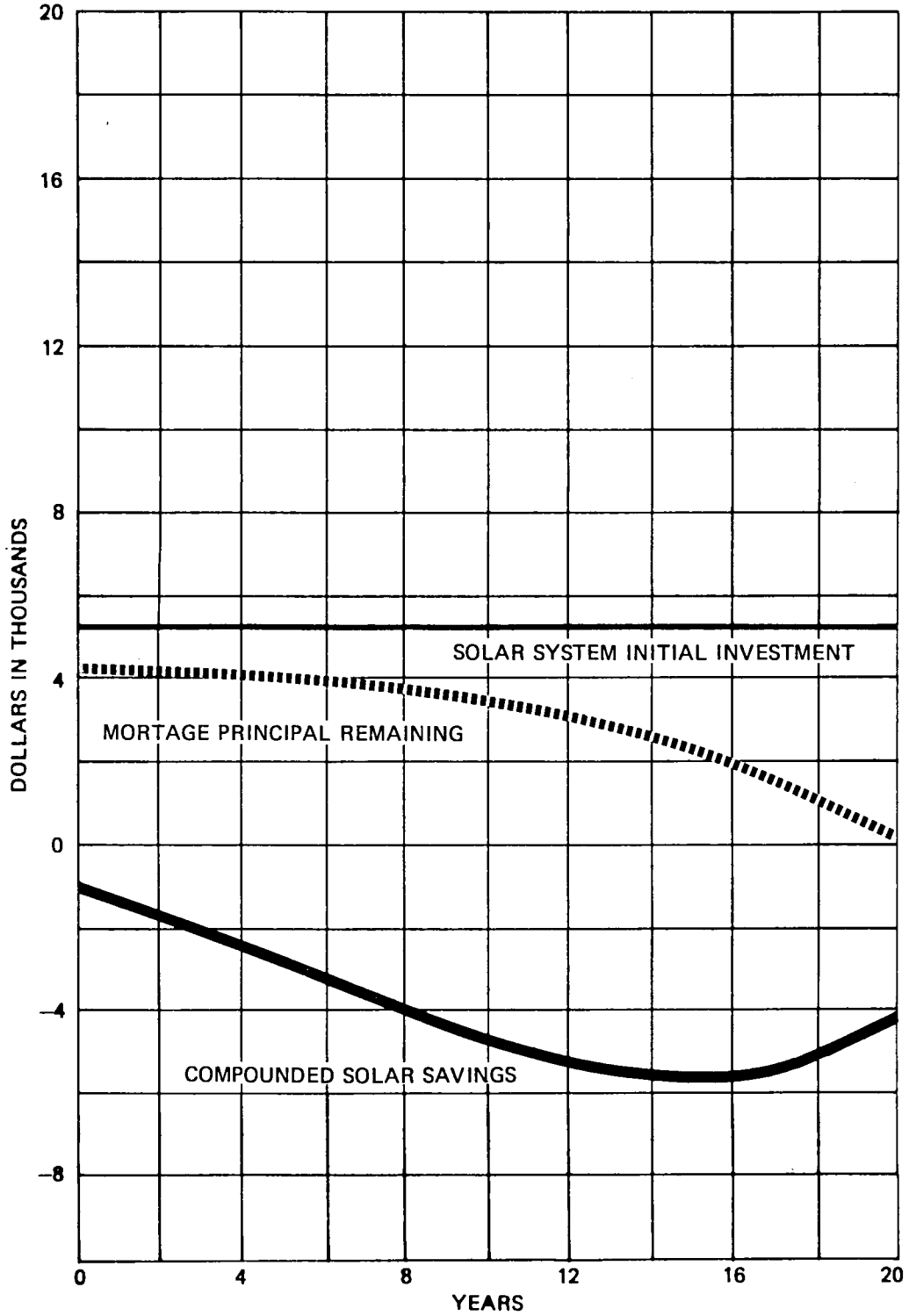

Figure 5.2-3 (d) Payback for Solar Energy System for Madison, Wisconsin

WASHINGTON, D. C.
OPTIMAL COLLECTOR AREA = 278 FT²

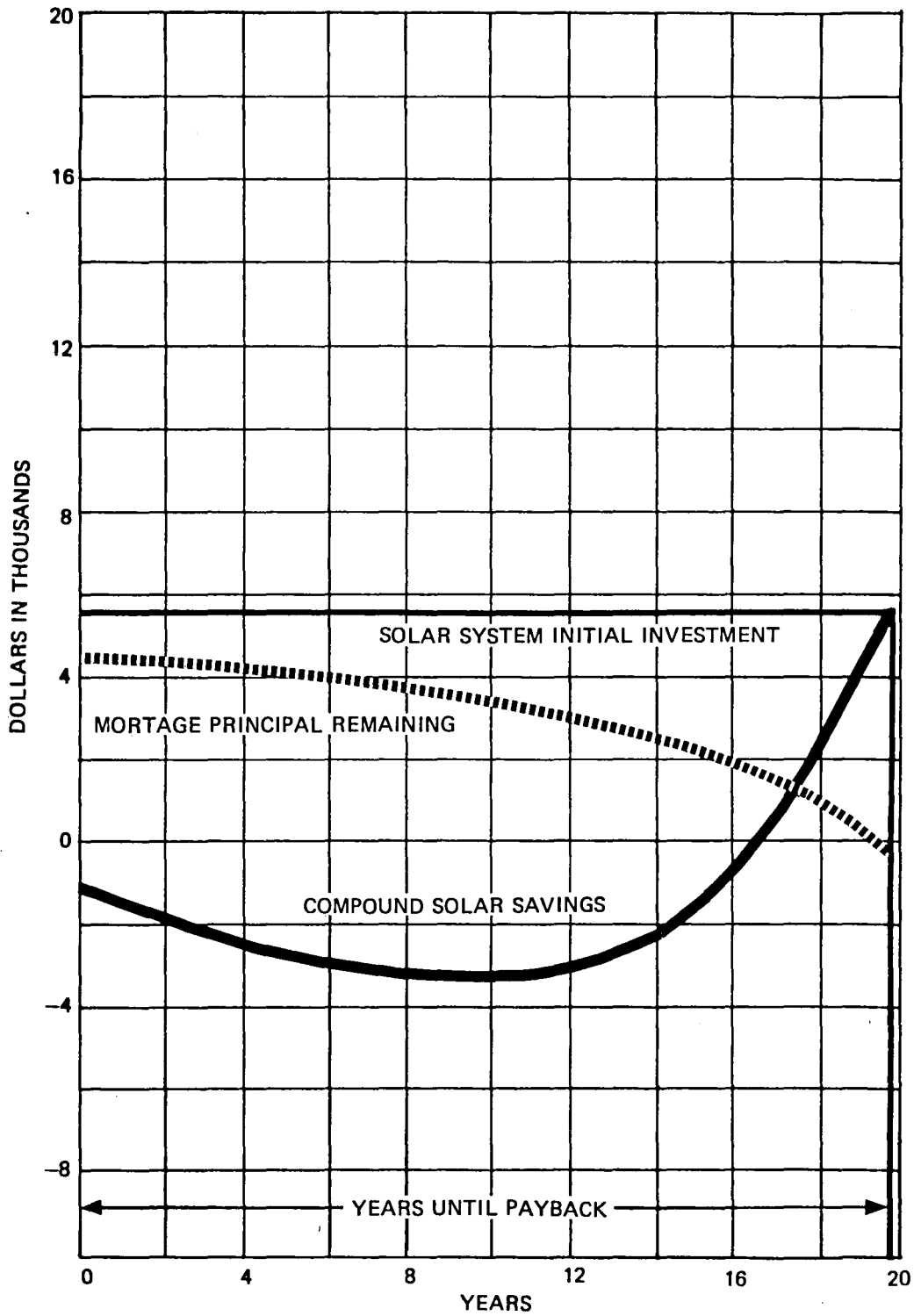

Figure 5.2-3 (e) Payback for Solar Energy System for Washington, D. C.

6. ECONOMIC UNCERTAINTY ANALYSIS

The economic evaluation methods presented in this report are based on the assumption that reliable values for economic variables can be assigned. However, there is an inherent uncertainty in predicting future expenses and benefits which is magnified by international economic instability. As a consequence, the results of both the life cycle cost analysis and the optimization procedures must be accepted with discretion and the effect of uncertainties must be evaluated.

For a given set of conditions, the change in the present worth of life cycle cumulative savings (Table 5.2-1), ΔLCCS , resulting from a change in a particular variable, Δx_j , can be approximated by the following:

$$\Delta\text{LCCS} = \frac{\partial\text{LCCS}}{\partial x_j} \Delta x_j \quad (13)$$

The expression for $\partial\text{LCCS}/\partial x_j$ can be obtained by direct differentiation of the life cycle savings equation. The life cycle cost model of Equations (1), (4) and (6)-(12) will be used for this analysis. The derivatives of these equations for each variable are given in Appendix B. To illustrate the use of these relationships, Uncertainty Analysis Tables 6-1 through 6-5 were made up for each analysis site. The tables give the change in solar system life cycle cumulative savings, ΔLCCS , caused by a 10 percent relative increase in each of the variables.

Table 6-1 shows, for example, that a 10 percent increase in the discount rate from 8.5 to 9.4 percent yields a decrease in the value of P_1 of approximately 2.43 giving a modified value of $P_1 = 24.14$. The value of P_2 decreases by 0.065 giving a modified value of $P_2 = 1.099$. The value of LCCS decreases by approximately \$103 or a relative change of 8 percent from the baseline value of \$1,250. By comparing the magnitude of ΔLCCS for each variable the relative sensitivity of the savings to a change in the variable can be assessed. From the table, it is evident that the savings are affected most by a change in fuel inflation, and least by a change in the down payment. The complex relationship of the variables to each other makes an intuitive approach unreliable and necessitates analysis of this type.

The information of Tables 6-1 through 6-5 can also be used to estimate the uncertainty in life cycle cumulative savings due to uncertainty in different variables. If all the economic parameters are subject to variation a reasonable estimate of savings uncertainty can be obtained by the following:

$$\Delta LCCS_{\text{prob}} = \left[\sum_{j=1}^N \left(\frac{\partial LCCS}{\partial x_j} \Delta x_j \right)^2 \right]^{\frac{1}{2}} \quad (14)$$

As an example, assume uncertainties of ± 10 percent in all eighteen of the variables listed in Table 6-5. The probable uncertainty estimate, using the data from the Table is:

Washington, DC

$\Delta LCCS_{\text{prob}} = \1515
 Cumulative Savings = \$1165

The $\Delta LCCS$ value is larger than the cumulative savings (See Table 5.2-1). Therefore, savings with this system depends on a favorable change in the economic variables, and is, in fact, possible. The results for other sites are as follows:

Albuquerque, NM

$\Delta LCCS_{\text{prob}} = \2254
 Cumulative Savings = \$4085

Ft. Worth, TX

$\Delta LCCS_{\text{prob}} = \1154
 Cumulative Savings = -\$264

Madison, WI

$\Delta LCCS_{\text{prob}} = \1180
 Cumulative Savings = -\$741

Tunkhannock, PA

$\Delta LCCS_{\text{prob}} = \1032
 Cumulative Savings = -\$1250

TABLE 6-1

UNCERTAINTY ANALYSIS FOR TUNKHANNOCK, PENNSYLVANIA

Optimized Collector Area = 209 FT²

COST PARAMETER (x_j)	NOMINAL VALUES	NOMINAL VALUE DELTA	$\frac{\partial P1}{\partial x_j}$	$\frac{\partial P2}{\partial x_j}$	$\frac{\partial LCCS}{\partial x_j}$	$\Delta LCCS$
AREA DEPENDENT COST (C_A)	10.510	1.0510	0.0	0.0	-243	-256
AREA INDEPENDENT COST (C_E)	2678.000	267.8000	0.0	0.0	-1	-312
ELECTRICAL ENERGY COST (C_{FE})	14.800	1.4800	0.0	0.0	132	195
FOSSIL FUEL COST (C_{FF})	6.790	0.6790	0.0	0.0	386	262
DOWN PAYMENT/INIT INV. (D)	0.200	0.0200	0.0	-0.074	359	7
FIRST YR. MISC COST/INIT INV (M)	0.005	0.0005	0.0	21.066	-102687	-51
FIRST YR. ASSESSED VAL/INIT INV (V)	0.0	0.0	0.0	0.0	0	0
SALVAGE VAL/INIT INV (G)	0.0	0.0	0.0	-0.196	954	0
ANNUAL MKT DISCOUNT RATE (d)	0.085	0.0085	-286.35	-7.626	-12120	-103
ANNUAL MKT RATE OF FUEL COST INC. (e)	0.125	0.0125	252.55	0.0	43475	543
ANNUAL INT. RATE ON MORTGAGE (i)	0.135	0.0135	0.0	4.406	-21479	-290
ANNUAL RATE OF GENERAL INFLATION (g)	0.100	0.0100	0.0	0.954	-4649	-46
PROPERTY TAX RATE (t)	0.0	0.0	0.0	0.0	0	0
EFFECTIVE INCOME TAX RATE (\bar{t})	0.300	0.0300	0.0	-0.838	4083	122
ELECTRICAL ENERGY LOAD (L_E)	15.030	1.5030	0.0	0.0	130	195
FOSSIL FUEL LOAD (L_F)	26.440	2.6440	0.0	0.0	99	262
ANNUAL SOLAR FRACTION (F)	0.330	0.0330	0.0	0.0	13861	457
FOSSIL FUEL UNIT EFFICIENCY (η_F)	0.600	0.0600	0.0	0.0	-4373	-262

UNCERTAINTY ANALYSIS FOR ALBUQUERQUE, NEW MEXICO

Optimized Collector Area = 313 FT²

COST PARAMETER (x_j)	NOMINAL VALUES	NOMINAL VALUE DELTA	$\frac{\partial P1}{\partial x_j}$	$\frac{\partial P2}{\partial x_j}$	$\frac{\partial LCCS}{\partial x_j}$	$\Delta LCCS$
AREA DEPENDENT COST (C_A)	10.510	1.0510	0.0	0.0	-364	-383
AREA INDEPENDENT COST (C_E)	2678.000	267.8000	0.0	0.0	-1	-312
ELECTRICAL ENERGY COST (C_{FE})	20.390	2.0390	0.0	0.0	278	567
FOSSIL FUEL COST (C_{FF})	7.410	0.7410	0.0	0.0	702	520
DOWN PAYMENT/INIT INV. (D)	0.200	0.0200	0.0	-0.074	440	9
FIRST YR. MISC COST/INIT INV (M)	0.005	0.0005	0.0	21.066	-125712	-63
FIRST YR. ASSESSED VAL/INIT INV (V)	0.0	0.0	0.0	0.0	0	0
SALVAGE VAL/INIT INV (G)	0.0	0.0	0.0	-0.196	1167	0
ANNUAL MKT DISCOUNT RATE (d)	0.085	0.0085	-286.35	-7.626	-71721	-610
ANNUAL MKT RATE OF FUEL COST INC. (e)	0.125	0.0125	252.55	0.0	103393	1292
ANNUAL INT. RATE ON MORTGAGE (i)	0.135	0.0135	0.0	4.406	-26295	-355
ANNUAL RATE OF GENERAL INFLATION (g)	0.100	0.0100	0.0	0.954	-5692	-57
PROPERTY TAX RATE (t)	0.0	0.0	0.0	0.0	0	0
EFFECTIVE INCOME TAX RATE (\bar{t})	0.300	0.0300	0.0	-0.838	4999	150
ELECTRICAL ENERGY LOAD (L_E)	12.960	1.2960	0.0	0.0	438	567
FOSSIL FUEL LOAD (L_F)	19.630	1.9630	0.0	0.0	265	520
ANNUAL SOLAR FRACTION (F)	0.808	0.0808	0.0	0.0	13463	1088
FOSSIL FUEL UNIT EFFICIENCY (η_F)	0.600	0.0600	0.0	0.0	-8674	-520

TABLE 6-3

UNCERTAINTY ANALYSIS FOR FORT WORTH, TEXAS

Optimized Collector Area = 209 FT²

COST PARAMETER (x_j)	NOMINAL VALUES	NOMINAL VALUE DELTA	$\frac{\partial P1}{\partial x_j}$	$\frac{\partial P2}{\partial x_j}$	$\frac{\partial LCCS}{\partial x_j}$	$\Delta LCCS$
AREA DEPENDENT COST (C_A)	10.510	1.0510	0.0	0.0	-243	-256
AREA INDEPENDENT COST (C_E)	2678.000	267.8000	0.0	0.0	-1	-312
ELECTRICAL ENERGY COST (C_{FE})	13.010	1.3010	0.0	0.0	252	328
FOSSIL FUEL COST (C_{FF})	7.030	0.7030	0.0	0.0	294	207
DOWN PAYMENT/INIT INV. (D)	0.200	0.0200	0.0	-0.074	359	7
FIRST YR. MISC COST/INIT INV (M)	0.005	0.0005	0.0	21.066	-102687	-51
FIRST YR. ASSESSED VAL/INIT INV (V)	0.0	0.0	0.0	0.0	0	0
SALVAGE VAL/INIT INV (G)	0.0	0.0	0.0	-0.196	954	0
ANNUAL MKT DISCOUNT RATE (d)	0.085	0.0085	-286.35	-7.626	-20482	-174
ANNUAL MKT RATE OF FUEL COST INC. (e)	0.125	0.0125	252.55	0.0	50850	636
ANNUAL INT. RATE ON MORTGAGE (i)	0.135	0.0135	0.0	4.406	-21479	-290
ANNUAL RATE OF GENERAL INFLATION (g)	0.100	0.0100	0.0	0.954	-4649	-46
PROPERTY TAX RATE (t)	0.0	0.0	0.0	0.0	0	0
EFFECTIVE INCOME TAX RATE (\bar{t})	0.300	0.0300	0.0	-0.838	4083	122
ELECTRICAL ENERGY LOAD (L_E)	14.560	1.4560	0.0	0.0	225	328
FOSSIL FUEL LOAD (L_F)	10.190	1.0190	0.0	0.0	203	207
ANNUAL SOLAR FRACTION (F)	0.652	0.0652	0.0	0.0	8205	535
FOSSIL FUEL UNIT EFFICIENCY (η_F)	0.600	0.0600	0.0	0.0	-3447	-207

TABLE 6-4

UNCERTAINTY ANALYSIS FOR MADISON, WISCONSIN

Optimized Collector Area = 243 FT²

COST PARAMETER (x_j)	NOMINAL VALUES	NOMINAL VALUE DELTA	$\frac{\partial P1}{\partial x_j}$	$\frac{\partial P2}{\partial x_j}$	$\frac{\partial LCCS}{\partial x_j}$	$\Delta LCCS$
AREA DEPENDENT COST (C_A)	10.510	1.0510	0.0	0.0	-283	-297
AREA INDEPENDENT COST (C_E)	2678.000	267.8000	0.0	0.0	-1	-312
ELECTRICAL ENERGY COST (C_{FE})	12.210	1.2210	0.0	0.0	162	198
FOSSIL FUEL COST (C_{FF})	6.540	0.6540	0.0	0.0	501	328
DOWN PAYMENT/INIT INV. (D)	0.200	0.0200	0.0	-0.074	385	8
FIRST YR. MISC COST/INIT INV (M)	0.005	0.0005	0.0	21.066	-110214	-55
FIRST YR. ASSESSED VAL/INIT INV (V)	0.0	0.0	0.0	0.0	0	0
SALVAGE VAL/INIT INV (G)	0.0	0.0	0.0	-0.196	1023	0
ANNUAL MKT DISCOUNT RATE (d)	0.085	0.0085	-286.35	-7.626	-16742	-142
ANNUAL MKT RATE OF FUEL COST INC. (e)	0.125	0.0125	252.55	0.0	49955	624
ANNUAL INT. RATE ON MORTGAGE (i)	0.135	0.0135	0.0	4.406	-23053	-311
ANNUAL RATE OF GENERAL INFLATION (g)	0.100	0.0100	0.0	0.954	-4990	-50
PROPERTY TAX RATE (t)	0.0	0.0	0.0	0.0	0	0
EFFECTIVE INCOME TAX RATE (\bar{t})	0.300	0.0300	0.0	-0.838	4383	131
ELECTRICAL ENERGY LOAD (L_E)	16.620	1.6620	0.0	0.0	119	198
FOSSIL FUEL LOAD (L_F)	30.830	3.0830	0.0	0.0	106	328
ANNUAL SOLAR FRACTION (F)	0.367	0.0367	0.0	0.0	14321	526
FOSSIL FUEL UNIT EFFICIENCY (η_F)	0.600	0.0600	0.0	0.0	-5461	-328

TABLE 6-5

UNCERTAINTY ANALYSIS FOR WASHINGTON, DC

Optimized Collector Area = 278 FT²

COST PARAMETER (x_j)	NOMINAL VALUES	NOMINAL VALUE DELTA	$\frac{\partial P1}{\partial x_j}$	$\frac{\partial P2}{\partial x_j}$	$\frac{\partial LCCS}{\partial x_j}$	$\Delta LCCS$
AREA DEPENDENT COST (C_A)	10.510	1.0510	0.0	0.0	-324	-340
AREA INDEPENDENT COST (C_E)	2678.000	267.8000	0.0	0.0	-1	-312
ELECTRICAL ENERGY COST (C_{FF})	19.780	1.9780	0.0	0.0	190	375
FOSSIL FUEL COST (C_{FF})	7.420	0.7420	0.0	0.0	457	339
DOWN PAYMENT/INIT INV. (D)	0.200	0.0200	0.0	-0.074	413	8
FIRST YR. MISC COST/INIT INV (M)	0.005	0.0005	0.0	21.066	-117963	-59
FIRST YR. ASSESSED VAL/INIT INV (V)	0.0	0.0	0.0	0.0	0	0
SALVAGE VAL/INIT INV (G)	0.0	0.0	0.0	-0.196	1095	0
ANNUAL MKT DISCOUNT RATE (d)	0.085	0.0085	-286.35	-7.626	-34319	-292
ANNUAL MKT RATE OF FUEL COST INC. (e)	0.125	0.0125	252.55	0.0	67932	849
ANNUAL INT. RATE ON MORTGAGE (i)	0.135	0.0135	0.0	4.406	-24674	-333
ANNUAL RATE OF GENERAL INFLATION (g)	0.100	0.0100	0.0	0.954	-5341	-53
PROPERTY TAX RATE (t)	0.0	0.0	0.0	0.0	0	0
EFFECTIVE INCOME TAX RATE (\bar{t})	0.300	0.0300	0.0	-0.838	4691	141
ELECTRICAL ENERGY LOAD (L_E)	15.560	1.5560	0.0	0.0	241	375
FOSSIL FUEL LOAD (L_F)	22.500	2.2500	0.0	0.0	151	339
ANNUAL SOLAR FRACTION (F)	0.459	0.0459	0.0	0.0	15571	715
FOSSIL FUEL UNIT EFFICIENCY (η_F)	0.600	0.0600	0.0	0.0	-5656	-339

7. SUMMARY AND CONCLUSIONS

Solar energy systems of the type installed at the Tunkhannock, Pennsylvania site are not economically beneficial under the assumed economic conditions at Tunkhannock, Pennsylvania; Fort Worth, Texas; and Madison, Wisconsin as shown in Figure 7-1. Only in Albuquerque, New Mexico and Washington, DC where the average solar insolation is 2018 Btu/Ft²/day and 1251 Btu/Ft²/day, respectively, and the conventional energy (electricity) cost is high (0.072 \$/kWh and 0.068 \$/kWh, respectively) is a solar energy system of the type described in this report profitable. Economic benefits from this solar energy system depend primarily on two factors: (1) maintaining or decreasing the initial investment required; (2) the continuing increase in the cost of conventional energy. The capability to maintain or decrease the cost of the system relative to its present level is uncertain. It depends on favorable tax treatment from the various levels of government, local through federal, as well as the continuing development of the solar energy industry. On the other hand, increases in the cost of conventional energy are virtually assured. From the economic uncertainty analysis in Section 6, where the conventional energy costs are medium to high, the savings with this system are 0.6 to 1.2 times more sensitive to increases in the solar energy system cost than to proportional increases in the conventional energy cost. This sensitivity demonstrates that there is approximately equivalent economic benefit for this solar energy system for proportional increases in conventional energy cost or reductions in the solar energy system cost.

The analysis and results given in this report can be used to guide a potential solar energy system buyer in evaluating the purchase of this type of heating/DHW system. To do this the solar insolation in the buyer's geographic area must be known. This data is available from several sources, including [9] and [10]. The cost of conventional energy must also be known. The local utility company can furnish rates from which a comparison cost based on 1000 kWh use can be computed in dollars per kWh or dollars per million Btu. The suppliers of fuel oil can furnish costs from which the rates in dollars per million Btu can be computed. These values can then be compared with the characteristics of the analysis sites given in Section 3.1. The results for that analysis site can be ascertained from Section 5.1 and 5.2. The primary economic parameters such as solar system cost, mortgage rates, inflation rates, discount rates, etc., are generally known by the buyer for his area. Deviations in these economic

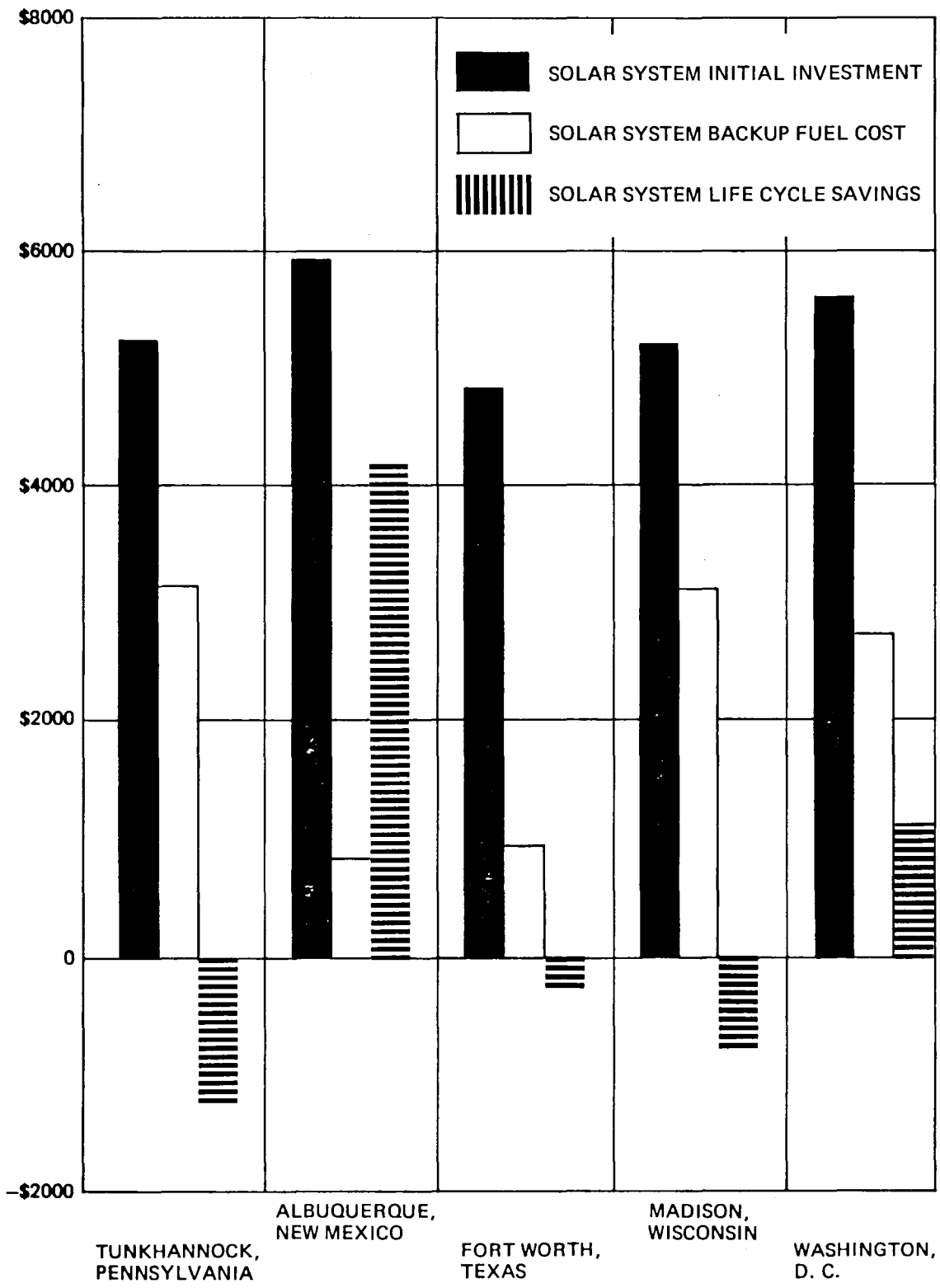

Figure 7-1 Economic Summary Chart for all Analysis Sites

parameters from the values assumed in developing the results in this report can be evaluated from material included in Section 6. The Δ LCCS values given in Table 6-1 through 6-5 were computed based on a 10 percent increase in the economic parameter in question. A 10 percent decrease simply means changing the sign of the value in the appropriate table. Larger increases or decreases in an economic parameter can also be obtained by multiplying the Δ LCCS value by the ratio of the desired increase to the 10 percent increase used in the original computation.

As an example of the discussion above, assume the buyer has determined that the characteristics of his locale are similar to Fort Worth, Texas, and is considering the results reported for this solar energy system in Fort Worth. He notes that the reported loss from Table 5.2-1 is -\$264, however, the conventional energy cost of his locale is \$0.040/kWh, instead of the \$0.044/kWh (Table 5.1-3) used in developing the Fort Worth loss. To modify the loss to consider the new rate the change is computed as:

$$\frac{0.040 - 0.044}{0.044} \times 100\% = 9.1\% \text{ (decrease)}$$

In Table 6-3 for Fort Worth it can be seen that a 10 percent increase in the electrical energy cost yields a value for Δ LCCS of \$328. The impact on the Life Cycle Cost Savings of a 9.1 percent decrease in fuel cost can be computed as follows:

$$\Delta\text{LCCS} = \frac{-9.1}{10.0} \times \$328 = -\$298 \text{ (decrease)}$$

Therefore, the new loss is:

$$-\$264 - \$298 = -\$562$$

Consequently the solar energy system moves to an even less competitive position because of the decreased cost of conventional energy.

The buyer can evaluate the result of a change in any of the economic parameters in the same manner. However, he should be aware that the parameters are sometimes inter-related and a change in one parameter may affect the ΔLCCS for several parameters. Consequently, the larger the changes the less the accuracy. However, approximate results may be obtained that prove of value in making a final decision.

8.0 REFERENCES

1. DOE/NASA CR-150515, Solafern Solar System Design Brochure, December 1977.
2. DOE/NASA CR-150760, Installation Package for a Domestic Solar Heating and Hot Water System, August 1978.
3. DOE/NASA CR-161592, Solar Energy System Performance Evaluation Seasonal Report for Fern Tunkhannock, Tunkhannock, Pennsylvania, prepared by the National Aeronautics and Space Administration, Solar Heating and Cooling Development Program, for the Department of Energy.
4. University of Wisconsin Engineering Experiment Station (EES) Report 49-3, f-Chart Users Manual, Version 3.0, June 1978.
5. Beckman, William A.; Klein, Sanford A.; Duffie, John A.; Solar Heating Design by the f-Chart Method, Wiley Interscience, New York, NY, 1977.
6. E. Streed, et. al., Thermal Data Requirements and Performance Evaluation Procedures for the National Solar Heating and Cooling Demonstration Program, NBSIR-76-1137, National Bureau of Standards, Washington, August 1976.
7. Brandemuehl, M. J. and Beckman, W. A., "Economic Evaluation and Optimization of Solar Heating Systems", Solar Energy, Vol. 23, Number 1, 1979, pp 1-10.
8. ASHRAE Standard 90-75, Energy Conservation in New Building Design, The American Society of Heating Refrigeration and Air Conditioning Engineers, Inc., New York, NY, 1975.
9. Cinquemani, V., et. al., "Input Data for Solar Systems." Prepared for the U.S. Department of Energy by the National Climatic Center, Asheville, North Carolina, 1978.
10. United States Department of Commerce, Climatic Atlas of the United States, Environmental Data Service, Reprinted by the National Oceanic and Atmospheric Administration, Washington, DC, 1977.

APPENDIX A
f-CHART PROCEDURE

APPENDIX A

F-Chart Procedure

Modifications are made to f-Chart to enable the program to be used to perform economic analysis of the following:

1. Systems that use heat pumps and fossil fuel space heating systems, as well as electric resistance heat.
2. Systems that use two different energy sources for domestic hot water heating and space heating.

The problem of analysis of the solar energy system with a conventional backup other than electric resistance heat is resolved by introducing Coefficients of Performance (COP's) (Item Nos. 47 and 48) whose values are dependent upon the types of backup systems. Typical COP's of heat pumps are computed from a heat pump model which uses as inputs the ambient and building temperature. Fossil fuel furnace COP's are assumed to be 0.60 unless different efficiencies, based on manufacturer's or other sources of data, are available.

The problem of analysis with two different energy sources is resolved by adjusting the COP's of the space heating system and domestic hot water system relative to the cost of electrical energy. This is necessary because the structure of f-Chart assumes electric energy to be the source for both space heating and domestic hot water. The adjustment factors are the adjusted ratios of the rates for the two energy sources used. The general expression for this is:

$$\left[\begin{array}{c} \text{SH COP}' \\ \text{or} \\ \text{HW COP}' \end{array} \right] = \frac{\text{Electrical Energy Rate } (\$/\text{million Btu})}{\left[\begin{array}{c} \text{SH Auxiliary Fuel Rate} \\ \text{or} \\ \text{HW Auxiliary Fuel Rate} \end{array} \right] (\$/\text{million Btu})} \times \left[\begin{array}{c} \text{SH COP} \\ \text{or} \\ \text{HW COP} \end{array} \right]$$

where the Electrical Energy Rate is the effective rate for 1000 kWh and the SH or HW Auxiliary Fuel Rate is the actual cost for fuel converted to \$/million Btu. Electrical Energy Rate will also be used for the value of Items Number 31 and 34 for systems of this configuration.

The value of SH COP' is input to the modified f-Chart program. This value is used to compute an adjusted total load. The load, in turn, is used to derive the solar fraction which is input to the f-Chart economic analysis subroutine.

Major considerations of the final report analysis procedure are the definitions of the loads that the system supports as it is analyzed in different geographic locations, and the sizing of the system to handle these loads at the various locations. The method is outlined in the following paragraphs.

The monthly long-term heating load at the selected analysis sites is computed in the f-Chart procedure from the following equation:

$$HL_{LT} = UA * HDD_{LT} - HTGEN \text{ DAYS}$$

where

UA is the modified building energy loss coefficient

HDD_{LT} is the monthly long-term average heating degree days

HTGEN is the internally generated heat computed from measured data.

It is to be noted that UA is a modified parameter. The modification is to compensate for the fact that housing standards differ from location to location, i.e., the construction standards for a Florida house are not suitable for the New York environment. The UA factor used is derived from the ASHRAE 90-75 Standard [8] as a function of long term heating degree days according to the appropriate U-value. The area, A, is derived from the building where the system is installed.

HTGEN is a factor that accounts for the part of the load which is internally generated. This is assumed to be the heat added which brings the building to the desired (comfortable) temperature when the outside ambient temperature is 65°F and no auxiliary heat is being added to the building. HTGEN, once derived, is assumed to be constant since it is a function of the life style of the occupants. The value of HL_{LT} is the monthly long-term average heat load input to f-Chart.

Additional technical and economic parameters that are input to f-Chart for the final report analysis are listed below with applicable comments.

1. Air SH + WH = 1, Liq SH + WH = 2, Air or Liq WH Only = 3

Comment: This is a definition of system type. The value is 1, if the system uses air collectors and supplies both space heat and domestic hot water; 2, if the system uses liquid collectors and supplies both space heat and domestic hot water; 3, if the system uses either type of collector and supplies only domestic hot water.

2. (Flow rate/col. area) * (Spec. heat)

Comment: If the system is an air system, this parameter is applicable. It is the air mass flow rate in lb/min divided by the gross collector area multiplied by the specific heat of air at standard conditions. The value of this parameter is computed for the system at the actual installation site. This value is then maintained constant as the collector size is optimized for all analysis sites.*

*f-Chart uses an optimized value of $2.15 \text{ Btu/Hr-}^\circ\text{F-Ft}^2$ for this parameter.

In resizing a system, only the collector size is varied. The system is not given the benefit of further optimization.

The system was not given the benefit of further optimization.

3. $\epsilon C_{\min}/UA$

Comment: If the system is a liquid system and uses a liquid to air heat exchanger in the space heating loop, this parameter is applicable. It is the manufacturer's heat exchanger effectiveness multiplied by the minimum capacitance rate through the heat exchanger and divided by the building energy loss coefficient. If the heat exchanger effectiveness is unknown, a default value of 0.5 is specified. The capacitance, C_{\min} , is the minimum product of mass flow rate and specific heat, which usually occurs on the air side. The UA value is the modified parameter applicable to the site. Deriving this value of UA has been previously discussed. The value of $\epsilon C_{\min}/UA$ is computed for the system at the actual installation site. This value is then maintained constant as the collector size is optimized for all analysis sites.*

4. Collector Area

Comment: This is the gross collector area which is optimized for all analysis sites. The optimization is extended to the actual installation site if an optimum sizing is not apparent in the original design. The predicted performance with optimal collector sizing is then compared to the predicted performance of the actual design and the actual measured performance.

5. $F_R (\tau\alpha)$

Comment: The basic value of $F_R (\tau\alpha)$ is derived from the collector analysis program. This value is more consistent with actual operation than the manufacturer's or laboratory single

*f-Chart uses an optimized value of 2.0 (dimensionless) for this parameter. In resizing a system only the collector size is varied. The system is not given the benefit of further optimization.

panel test values. If the system has a heat exchanger between collectors and storage, the derived value of $F_R(\tau\alpha)$ was modified by the F_R'/F_R factor as outlined in Section 2.4.4 of EES Report 49-3 (f-Chart Users Manual). [4] Note that the values input to f-Chart are assumed to be derived in accordance with ASHRAE specified method.

6. F_{R,U_L}

Comment: Same comment as Item 5.

7. Incidence Angle Modifier

Comment: In general, the default value of 0 is used. For evacuated tube collectors modeled as flat plate collectors the collector angle incidence modifier is obtained from the collector manufacturer.

8. Number of Transparent Covers

Comment: This is specified according to the characteristics of the collector.

9. Collector Slope

Comment: Collector Slope is changed according to the latitude of the site and the type of system. When the site analyzed is the existing site, the actual slope value is used. For other analysis sites the slope is computed as follows:

- Latitude +10° if space heat and domestic hot water
- Latitude if domestic hot water only

10. Azimuth Angle

Comment: At sites other than the existing installation site the azimuth angle is 0° . At the existing site the actual azimuth angle was used for analysis. However, any resulting performance degradation is noted.

11. Storage Capacity

Comment: This parameter is computed as the product of storage mass and specific heat divided by collector area for the existing site. The same value of storage capacity is used for all sites.

12. Effective Building UA

Comment: The building UA, if not known, is derived from the measurement data contained in the Seasonal Report [3]. The computed value of UA is compared for reasonableness with a corresponding value of UA derived from ASHRAE Standard 90-75. For other analysis sites the value of UA is derived from ASHRAE 90-75 as a function of building type and heating degree-days for each site.

13. Constant Daily Building Heat Generation

Comment: For residential type buildings, this parameter is derived from the measurement data contained in the Seasonal Report [3]. The derived value is held constant for all analysis sites.

14. Hot Water Usage

Comment: An effective average hot water consumption rate that accounts for actual load plus standby losses was computed from the following equation:

$$\text{HWCSMPEFF} = \frac{\text{HWSE} + \text{HWAT}}{\text{C}_p \left(\frac{\text{TMAIN} + \text{TSET}}{2} \right) * (\text{TSET} - \text{TMAIN}) * \text{RHO} \left(\frac{\text{TMAIN} + \text{TSET}}{2} \right)}{\text{Number of Days in Month}}$$

15. Water Set Temperature

Comment: The actual value of this parameter at the existing site is used for all analysis sites.

16. Water Main Temperature

Comment: The inputs for this parameter are a series of monthly values. The actual monthly value at the existing site is referenced to the average long-term ambient for the month for analysis at that site. For analysis at other sites the monthly value of TMAIN was established by site measurement at a nearby site referenced to the average long-term ambient for the month. (See Appendix C)

17. City Call Number

Comment: If the analysis site is located at a city listed in the November 1978 Input Data For Solar Systems that site is entered into the f-Chart data record. If the analysis site is not a part of the data record, an interpolative routine computes the data for any arbitrary site from nearby sites where data is available.

18. Thermal Print Out by Month

Comment: None

19. Economic Analysis

Comment: In general, all runs made for Final Reports specify print out of economic analysis.

20. Use Optimized Collector Area = 1, Specified Area = 2

Comment: In general the runs made for Final Reports use an optimized collector area.

21. Solar System Thermal Performance Degradation

Comment: A value of zero percent is used.

22.-46. Economic Parameters

Comment: The values of the economic parameter were worked out between MSFC and IBM for the Final Reports. The source of the value is given in the notes on page A-11.

Residential

<u>Item</u>	<u>Variable Description</u>	<u>Value</u>	<u>Units</u>	<u>Source</u>
22	Period of Economic Analysis	20	Yrs.	SAI ¹
23	Collector Area Dependent System Costs			MSFC ²
24	Constant Solar Costs			MSFC ²
25	Down Payment (% of Original Investment)	20	%	SAI ¹
26	Annual Interest Rate on Mortgage	13.5	%	MSFC ²
27	Term of Mortgage	20	Yrs.	SAI ¹
28	Annual NOminal (Market) Discount Rate	8.5	%	SAI ¹
29	Extra Insur., Maint. in Year 1	0.5	%	MSFC ²
			(% of Orig. Inv.)	
30	Annual % Increase in Above Expenses	10.0	%	MSFC ²
31	Present Cost of Solar Backup Fuel (BF)			Actual ³
32	BF Rise: %/Yr. = 1, Sequence of Values = 2	1		

Residential (Continued)

<u>Item</u>	<u>Variable Description</u>	<u>Value</u>	<u>Units</u>	<u>Source</u>
33	Annual Rate of BF Rise			
	Electricity	12.5	%	MSFC ²
	Oil	12.5	%	MSFC ²
	Natural Gas	12.5	%	MSFC ²
34	Present Cost of Conventional Fuel (CF)			Same as #31 ⁴
35	CF Rise: %/Yr. = 1, Sequence of Values - 2	1		
36	Annual Rate of CF Rise			
	Electricity	12.5	%	MSFC ²
	Oil	12.5	%	MSFC ²
	Natural Gas	12.5	%	MSFC ²
37	Economic Print Out by Year = 1, Cumulative = 2	2		Analyst Option
38	Effective Federal State Income Tax Rate			
	Residential	30	%	SAI ¹
	Commercial	48	%	MSFC ²
39	True Property Tax Rate Per \$ of Original Investment	0	%	SAI ¹
40	Annual % Increase in Property Tax Rate	NA If #39 is "0"		
41	Calc. Rt. of Return on Solar Investment? Yes = 1, No = 2			Analyst
42	Resale Value (% of Original INvestment)	0		MSFC ^{2,5}
43	Income Producing Building, Yes = 1, No = 2			Site Dependent
44	Dprc.: Str. In. = 1, Dc. Bal. = 2, Sm-yr.-Dgt. = 3, None = 4	2	%	MSFC ²
45	If 2, What % of Str. Ln. Dprc. Rt. is Desired	150	%	MSFC ²
46	Useful Life for Deprec. Purposes	20	Yrs.	MSFC ²

47. & 48. Economic COPs for Auxiliary Systems

Comment: These are new parameters defined for f-Chart to account for economic analysis of solar systems having auxiliary backup other than electric resistance heat. The default values of these parameters are as follows:

Heat Pump Auxiliary	COP = 2
Fossil Fuel Auxiliary	COP = 0.6
Electric Resistance	COP = 1.0

The values of the basic COPs are modified, according to the method described on page A-2, to account for differences between the fuel used for the domestic hot water and the fuel used for space heating.

NOTES:

1. Source is Science Applications, Inc. (SAI) Draft Final Report on "Comparison of Solar Heat Pump Systems to Conventional Methods for Residential Heating, Cooling, and Water Heating," April 1979.
2. These items are based on judgment and best experience.
3. The actual current utility rates for the analysis sites selected are obtained. (See Appendix D).
4. The assumption for final report analysis is that the backup system actually used for the installation is the same type of system that would be used if the solar system was not installed.
5. The declining balance technique never permits 100% depreciation of the asset no matter how long the period. The balance remaining at the end of the system lifetime is treated, for accounting purposes, as salvage value is presumed to exist.

APPENDIX B

ECONOMIC UNCERTAINTY ANALYSIS
EQUATIONS

APPENDIX B

ECONOMIC UNCERTAINTY ANALYSIS EQUATIONS

1. Area dependent investment costs (C_A)

$$\Delta LCCS_{CA} = -P_2^A (\Delta C_A)$$

2. Area independent investment costs (C_E)

$$\Delta LCCS_{CE} = -P_2 (\Delta C_E)$$

3. Ratio of downpayment to initial investment (D)

$$\Delta LCCS_D = -(C_A^A + C_E) \left\{ 1 - (1 - \bar{t}) \frac{f(N, 0, d)}{f(N, 0, i)} + \bar{t} f(N, i, d) \left[i - \frac{1}{f(N, 0, i)} \right] \right\} (\Delta D)$$

4. Ratio first year's misc. costs to init. inv. (M)

$$\Delta LCCS_M = -(C_A^A + C_E) \left[(1 - C\bar{t}) f(N, g, d) \right] (\Delta M)$$

5. Ratio first year's assessed value to init. inv. (V)

$$\Delta LCCS_V = -(C_A^A + C_E) \left[t (1 - \bar{t}) f(N, g, d) \right] (\Delta V)$$

6. Ratio salvage or resale value to init. inv. (G)

$$\Delta LCCS_G = -(C_A^A + C_E) \left[\frac{-1}{(1 + d)^N} \right] (\Delta G)$$

7. Annual market discount rate (d)

$$\begin{aligned} \Delta LCCS_d = & (C_{FE}L_E + C_{FF}L_F/\eta_F)F(1 - C\bar{t}) \frac{\partial}{\partial d} f(N, e, d) (\Delta d) \\ & -(C_A A + C_E) \left\{ \frac{1-D}{f(N, 0, i)} \frac{\partial}{\partial d} f(N, 0, d) + \right. \\ & \left[(1 - C\bar{t}) M + t (1 - \bar{t}) V \right] \frac{\partial}{\partial d} f(N, g, d) - \\ & (1 - D) \bar{t} \left[\frac{1}{f(N, 0, i)} \frac{\partial}{\partial d} f(N, 0, d) + \right. \\ & \left. \left(i - \frac{1}{f(N, 0, i)} \right) \frac{\partial}{\partial d} f(N, i, d) \right] + \frac{NG}{(1 + d)^{N+1}} \\ & \left. - \frac{C\bar{t}}{N} \frac{\partial}{\partial d} f(N, 0, d) \right\} (\Delta d) \end{aligned}$$

8. Annual market rate of fuel price increase (e)

$$\Delta LCCS_e = (C_{FE}L_E + C_{FF}L_F/\eta_F)F(1 - C\bar{t}) \frac{\partial}{\partial e} f(N, e, d) (\Delta e)$$

9. Annual interest rate on mortgage (i)

$$\begin{aligned} \Delta LCCS_i = & -(C_A A + C_E) \left\{ (D - 1) (1 - \bar{t}) \frac{f(N, 0, d)}{f(N, 0, i)} \right. \\ & \left. \frac{\partial}{\partial i} f(N, 0, i) - \bar{t} (1 - D) \left[i - \frac{1}{f(N, 0, i)} \right] \right. \\ & \left. \frac{\partial}{\partial i} f(N, i, d) - \bar{t} (1 - D) f(N, i, d) \right. \\ & \left. \left[1 + \frac{1}{f(N, 0, i)^2} \frac{\partial}{\partial i} f(N, 0, i) \right] \right\} \Delta i \end{aligned}$$

10. Annual rate of general inflation (g)

$$\Delta LCCS_g = -(C_A^A + C_E) \left[(1 - C\bar{t}) M + (1 - \bar{t}) t V \right] \frac{\partial}{\partial g} f(N, g, d) (\Delta g)$$

11. Effective income tax rate (\bar{t})

$$\Delta LCCS_{\bar{t}} = -(C_{FE}L_E + C_{FF}L_F/\eta_F) FCf(N, e, d) (\Delta \bar{t})$$

$$(C_A^A + C_E) \left\{ (D - 1) \frac{f(N, 0, d)}{f(N, 0, i)} + (D - 1) f(N, i, d) \right.$$

$$\left[i - \frac{1}{f(N, 0, i)} \right] - t Vf(N, g, d) - C \left[Mf(N, g, d) + \right.$$

$$\left. \left. \frac{1}{N} f(N, 0, d) \right] \right\} (\Delta \bar{t})$$

12. Property tax rate (t)

$$\Delta LCCS_t = -(C_A^A + C_E) (1 - \bar{t}) Vf(N, g, d) (\Delta t)$$

13. Cost of electrical energy in the first year (C_{FE})

$$\Delta LCCS_{C_{FE}} = P_1 L_E F (\Delta C_{FE})$$

14. Cost of fossil fuel in the first year (C_{FF})

$$\Delta LCCS_{C_{FF}} = P_1 (L_F/\eta_F) F (\Delta C_{FF})$$

15. Annual hot water load (L_E)

$$\Delta LCCS_{L_E} = P_1 C_{FE} F (\Delta L_E)$$

16. Annual heating load (L_F)

$$\Delta LCCS_{L_F} = P_1 (C_{FF}/\eta_F) F (\Delta L_F)$$

17. Coefficient of Performance

$$\Delta \text{LCCS}_{\eta_F} = -(P_1 L_F C_{FF} / \eta_F^2) (\Delta \eta_F)$$

18. Annual load fraction supplied by solar (F)

$$\Delta \text{LCCS}_F = P_1 (C_{FE} L_E + C_{FF} L_F / \eta_F) (\Delta F)$$

NOTE: Three functions used above require definition, as follows:

$$f(N, a, b) = \frac{1}{b-a} \left[1 - \left(\frac{1+a}{1+b} \right)^N \right]$$

$$\frac{\partial}{\partial a} f(N, a, b) = \frac{1}{b-a} \left[f(N, a, b) - \frac{N}{1+a} \left(\frac{1+a}{1+b} \right)^N \right]$$

$$\frac{\partial}{\partial b} f(N, a, b) = \frac{1}{b-a} \left[\frac{N}{1+b} \left(\frac{1+a}{1+b} \right)^N - f(N, a, b) \right]$$

APPENDIX C

MONTHLY AVERAGE WATER
SUPPLY TEMPERATURES

TABLE C-1

MONTHLY AVERAGE WATER SUPPLY TEMPERATURES IN °F

SITE NAME	MONTH											
	J	F	M	A	M	J	J	A	S	O	N	D
TUNKHANNOCK, PA	54	48	49	59	63	67	71	72	72	71	63	58
ALBUQUERQUE, NM	66	66	66	70	74	76	80	83	79	74	71	66
FORT WORTH, TX	42	49	58	65	73	80	82	83	78	63	53	49
MADISON, WI	34	37	39	50	61	68	70	72	68	63	54	36
WASHINGTON, DC	42	42	52	56	63	67	67	78	79	68	55	46

APPENDIX D

**ENERGY COST FOR
ANALYSIS SITES**

TUNKHANNOCK, PA

GAS

NOT APPLICABLE

ELECTRICITY

0.0373\$/kWh STRAIGHT RATE

ALSO	SERVICE CHARGE	5.00 \$/MONTH
	SURCHARGE	4.6 %
	TAX	0
	FUEL ADJUSTMENT	0.0065 \$/kWh

1000 kWh EFFECTIVE RATE = 0.05053 \$/kWh = 14.80 \$/Million Btu

FUEL OIL

0.95 \$/Gallon

1 GALLON = 140,000 Btu

TAX 0

EFFECTIVE RATE = 6.79 \$/Million Btu

ECONOMIC COP = $\frac{14.80 \times 0.6 \text{ (Furnace Efficiency)}}{6.79}$ = 1.31 (Space Heating)

ALBUQUERQUE, NM

GAS

0-165 THERMS 0.0803\$/THERM
165-340 THERMS 0.0826\$/THERM
340+ THERMS 0.0966\$/THERM
SERVICE CHARGE \$1.25
FUEL ADJUSTMENT 0.2114\$/THERM
TAX 4%

1 THERM = 100,000 BTU

EXAMPLE

30 THERMS * 0.2114 = \$6.34

EFFECTIVE RATE OF 10 MILLION BTU = 3.16\$/Million Btu

ELECTRICITY

0-200 kWh 0.05294\$/kWh
200-800 kWh 0.04794\$/kWh
800+ kWh 0.03894\$/kWh NOV-MAY
OR
800 + kWh 0.04094\$/kWh JUN-OCT

FUEL RATE ADJUSTMENT 0.016680\$/kWh
SERVICE CHARGE \$2.60
TAX 4.5%

1000 kWh EFFECTIVE RATE YEAR-AROUND = 0.069576 \$/kWh = 20.39 \$/Million Btu

FUEL OIL

0.999\$/GALLON
TAX 4%

1 GALLON = 140,000 BTU

EFFECTIVE RATE = 7.41 \$/Million Btu

PROPANE

0.66\$/GALLON FOR FIRST 500 GALLONS

TAX 4%

ECONOMIC COP = $\frac{20.39 \times 0.6 \text{ (Furnace Efficiency)}}{7.41}$ = 1.65 (Space Heating)

FORT WORTH, TEXAS

GAS

0-1000 MCF 4.05\$/MCF
1000+MCF 2.433\$/MCF

MCF = 1000 FT³ = 10⁶ BTU

SERVICE CHARGE 0
TAX 0

EFFECTIVE RATE OF 10 MILLION BTU = 4.05\$/Million Btu

ELECTRICITY

0- 25 kWh \$6.00 (MINIMUM)
25+ kWh 0.0285\$/kWh
FUEL CHARGE 0.008899\$/kWh
TAX 4%

1000 kWh EFFECTIVE RATE = 0.0444\$/kWh = 13.01\$/Million Btu

FUEL OIL

EFFECTIVE RATE (FOR COMPARATIVE ANALYSIS) = 7.03 \$/Million Btu

PROPANE

0.62\$/GALLON
TAX 0

1 GALLON = 91,500 BTU

ECONOMIC COP = $\frac{13.01 \times 0.6 \text{ (Furnace Efficiency)}}{7.03}$ = 1.11 (Space Heating)

MADISON, WI

GAS

0-20 THERMS 0.28732\$/THERM
20-50 THERMS 0.27936\$/THERM
50+ THERMS 0.26892\$/THERM

1 THERM = 100,000 BTU

FUEL RATE CHARGE 0.0762\$/THERM
TAX 0.
SERVICE CHARGE 2.00\$/MONTH

ELECTRICITY

0- 100 kWh 0.0360\$/kWh
100- 500 kWh 0.0350\$/kWh
500-1000 kWh 0.0320\$/kWh
1000+ kWh 0.0275\$/kWh

FUEL RATE CHARGE (JAN) 0.00607\$/kWh
TAX 0.
SERVICE CHARGE 2.00\$/MONTH

1000 kWh EFFECTIVE RATE = 0.04167\$/kWh = 12.21 \$/Million Btu

FUEL OIL

0.919\$/GALLON
TAX 0 FOR RESIDENTIAL 4% FOR COMMERCIAL

1 GALLON = 140,000 BTU

EFFECTIVE RATE = 6.54 \$/Million Btu

PROPANE

0.678\$/GALLON
TAX 0

1 GALLON = 91.500 BTU

ECONOMIC COP = $\frac{12.21 \times 0.6 \text{ (Furnace Efficiency)}}{6.54}$ = 1.12 (Space Heating)

WASHINGTON, DC

GAS

0.3255\$/THERM

1 THERM = 100,000 BTU

SERVICE CHARGE 5.00\$/Month

TAX 5%

EFFECTIVE RATE OF 10 MILLION BTU = 3.94\$/Million Btu

ELECTRICITY

NOV - MAY

JUNE - OCT

WINTER RATES

SUMMER RATES

0 - 600 kWh 0.06024 \$/kWh
600 - 1500 kWh 0.05334 \$/kWh
1500 + kWh 0.04289 \$/kWh

0 - 600 0.06024 \$/kWh
600 - 1500 0.06924 \$/kWh
1500 + 0.26638 \$/kWh

SERVICE CHARGE 5.00\$/MONTH

TAX 16% OF FIRST \$15.00 (\$2.40 MAX)

FUEL CHARGE 0.01500 \$/kWh (INCLUDED IN ABOVE RATES)

1000 kWh EFFECTIVE RATE = 0.0675 \$/kWh YEAR-ROUND = 19.78 \$/Million Btu

FUEL OIL

0.989\$/GALLON

1 GALLON = 140,000 BTU

TAX 5%

EFFECTIVE RATE = 7.42 \$/Million Btu

PROPANE

1.00\$/GALLON

1 GALLON = 91,500 BTU

TAX 5%

ECONOMIC COP = $\frac{19.78 \times 0.6 \text{ (Furnace Efficiency)}}{7.42}$ = 1.60 (Space Heating)

APPENDIX E

DETERMINATION OF ENERGY
LOSS (UA) COEFFICIENTS

DETERMINATION OF THE UA VALUE OF DETACHED ONE AND TWO FAMILY DWELLINGS
(A1) AND ALL OTHER RESIDENTIAL BUILDING 3 STORIES OR LESS

1. WALLS

- a. Determine the gross area of all exterior walls, including windows and doors. (A_w)
- b. Refer to Figure E-1 [8] to obtain combined thermal transmittance value (U_{ow} value) for geographic region.
- c. Multiply gross wall area by value found in (b) to derive $U_{ow}A_w$ for walls.

2. CEILING

- a. Determine total interior surface of ceiling.
- b. For geographic areas where:
 - o $HDD \leq 8000$, $U_{oc} = 0.05 \text{ BTU/H-}^\circ\text{F-FT}^2$
 - o $HDD > 8000$, $U_{oc} = 0.04 \text{ BTU/H-}^\circ\text{F-FT}^2$
- c. Multiply interior ceiling area by value found in (b) to derive $U_{oc}A_c$

3. FLOORS

a. FLOORS OVER UNHEATED SPACES

- (1) Determine the interior floor area (A_f)
- (2) Refer to Figure E-2 to obtain thermal transmittance value (U_{of} value) in geographic region.

- (3) Multiply interior floor area by value found in (2) to derive $U_{OF}A_F$ for floors.

b. SLAB ON GRADE FLOORS

- (1) Determine the perimeter of the exposed edge of the floor.
- (2) Multiply perimeter length by a factor determined from the following table to derive $C_{HL}L_F$ for floor.

T_D Outdoor Design Temperature ($^{\circ}F$)	C_{HL} Heat Loss Coefficient (BTU/H-FT)
-20 to -30	50
-10 to -20	45
0 to 10	40
Above 10	35

- (3) Divide the $C_{HL}L_F$ product by the difference of the outside design temperature (T_D) and the average winter building temperature (T_B).

4. BUILDING UA FACTOR

The UA factors determined in Steps (1) - (3) are added as follows:

$$UA = U_{OW}A_W + U_{OC}A_C + U_{OF}A_F \text{ (or } C_{HL}L_F/(T_B - T_D))$$

5. If the UA factor for the building at the actual site is known, computing the UA factor as described in Steps (1) - (4) will give a comparison value. If this comparison value is less than the given value at the actual site, the given value should be used in f-Chart, and the computed value for every other analysis site should be increased by the percentage difference from the computed value at the actual site. Similarly, if the comparison value is greater than the given value for the actual site, the given value should be used, and the computed value for every other analysis site should be decreased by the percentage difference from the computed value at the actual site.

Figure E-1

U_o WALLS—TYPE "A" BUILDINGS

TYPE A BUILDINGS SHALL INCLUDE:

A 1 DETACHED ONE AND TWO FAMILY DWELLINGS

A 2 ALL OTHER RESIDENTIAL BUILDINGS, THREE
STORIES OR LESS, INCLUDING BUT NOT LIMITED
TO:

MULTI-FAMILY DWELLINGS
HOTELS AND MOTELS

ANNUAL CELSIUS HEATING DEGREE DAYS (18 C BASE)
(IN THOUSANDS)

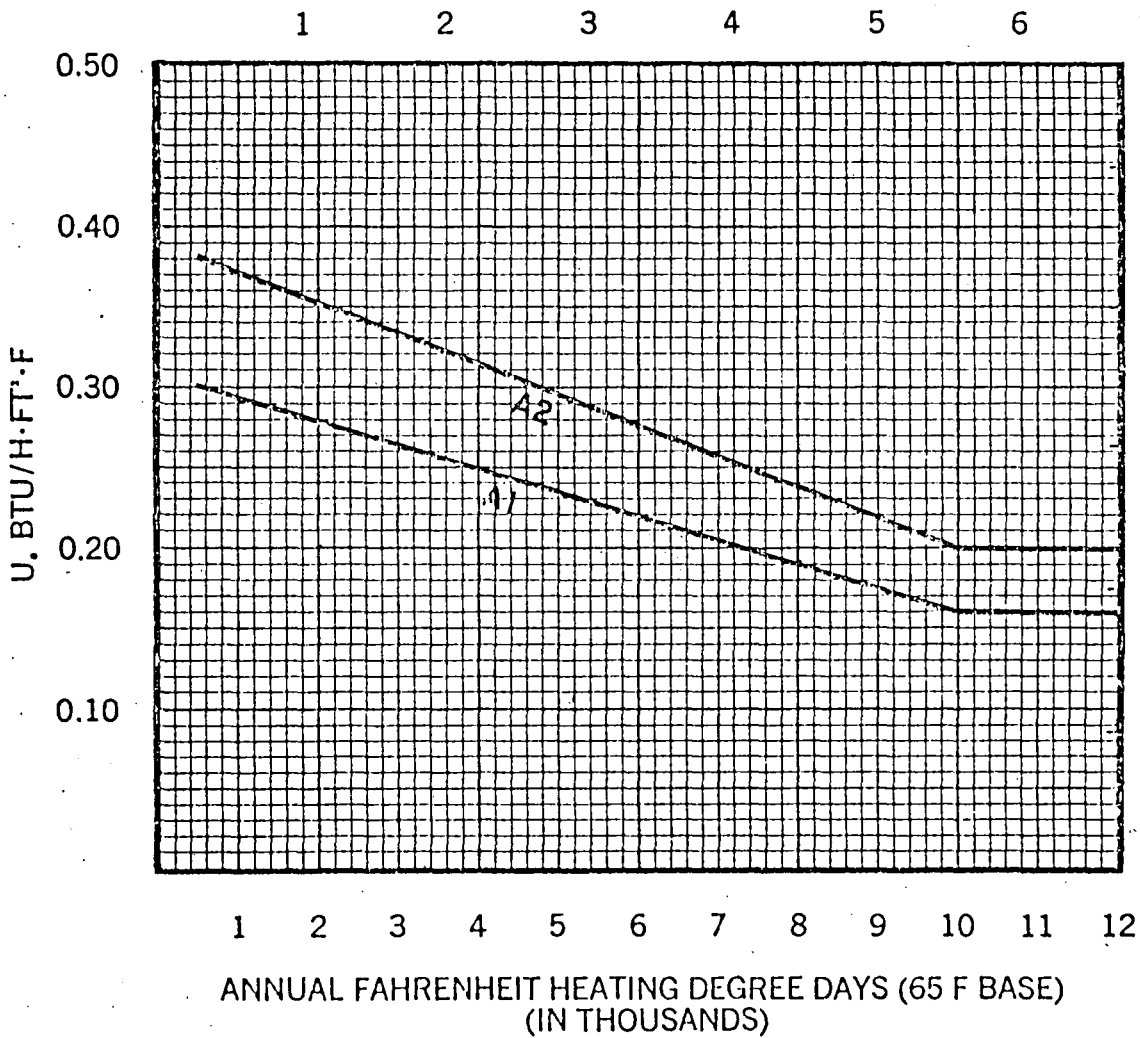
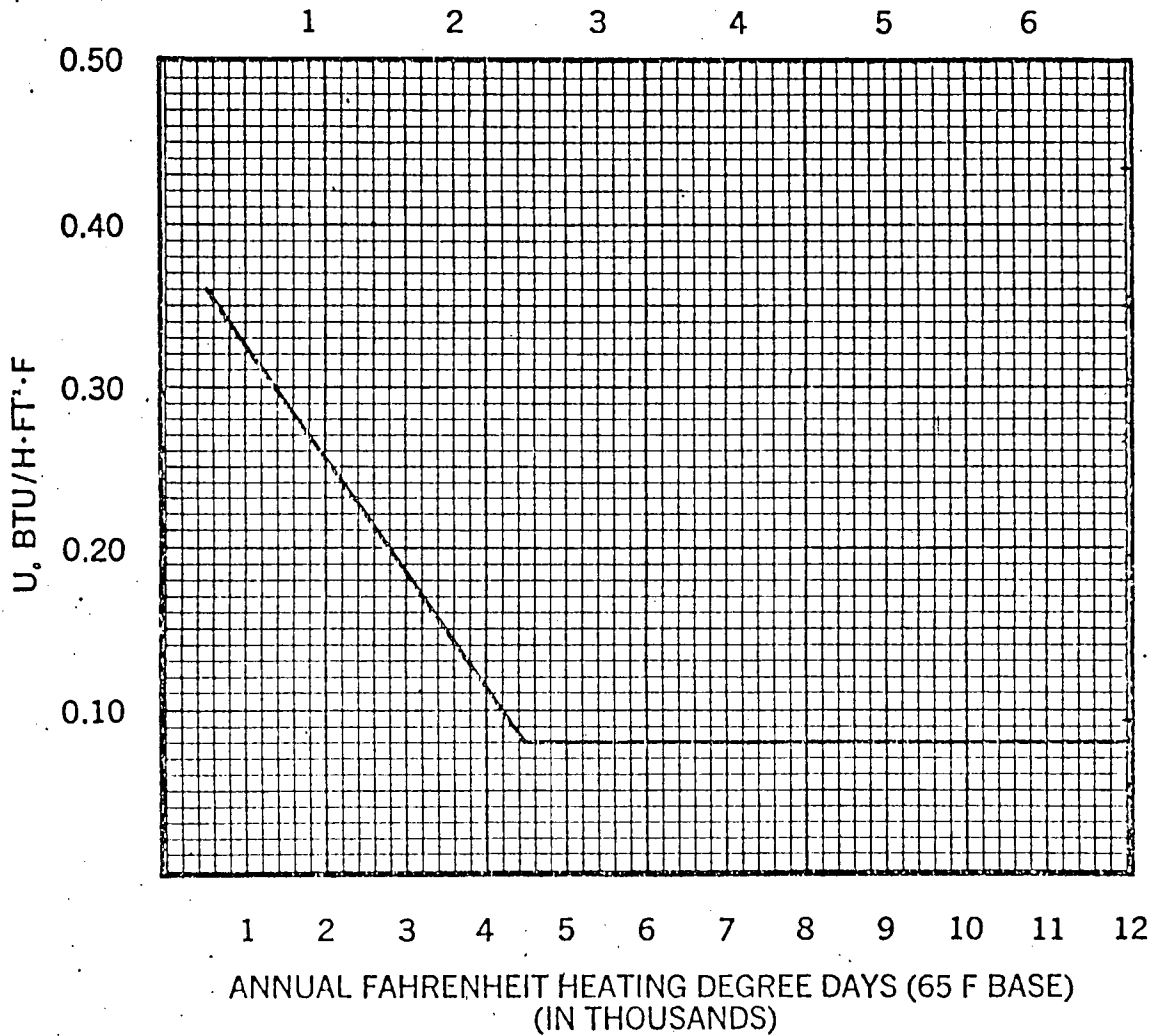

Figure E-2

U_o VALUES—FLOORS OVER UNHEATED SPACES

ANNUAL CELSIUS HEATING DEGREE DAYS (18 C BASE)
(IN THOUSANDS)



End of Document