

## N O T I C E

THIS DOCUMENT HAS BEEN REPRODUCED FROM  
MICROFICHE. ALTHOUGH IT IS RECOGNIZED THAT  
CERTAIN PORTIONS ARE ILLEGIBLE, IT IS BEING RELEASED  
IN THE INTEREST OF MAKING AVAILABLE AS MUCH  
INFORMATION AS POSSIBLE

NI

NASA  
Technical Memorandum 82617

AVRADCOM  
Technical Report 81-C-10

# Effect of a Part-Span Variable Inlet Guide Vane on the Performance of a High-Bypass Turbofan Engine

(NASA-TM-82617) EFFECT OF A PART-SPAN  
VARIABLE INLET GUIDE VANE ON THE PERFORMANCE  
OF A HIGH-BYPASS TURBOFAN ENGINE (NASA)  
15 p HC A02/MF A01

N81-25081

CSCL 21E

Unclas  
63/01 26571

George A. Bobula  
Propulsion Laboratory  
AVRADCOM Research and Technology Laboratories  
*Lewis Research Center*  
*Cleveland, Ohio*

and

Ronald H. Soeder and Leo A. Burkardt  
*Lewis Research Center*  
*Cleveland, Ohio*

Prepared for the  
Seventeenth Joint Propulsion Conference  
cosponsored by the AIAA, SAE, and ASME  
Colorado Springs, Colorado, July 27-29, 1981



**NASA**



EFFECT OF A PART-SPAN VARIABLE INLET GUIDE VANE ON THE  
PERFORMANCE OF A HIGH-BYPASS TURBOFAN ENGINE

George A. Bobula\*  
Propulsion Laboratory  
AVRADCOM Research and Technology Laboratories  
Lewis Research Center  
Cleveland, Ohio

and

Ronald H. Soeder\*\* and Leo A. Burkardt\*  
National Aeronautics and Space Administration  
Lewis Research Center  
Cleveland, Ohio

Abstract

The ability of a part-span variable inlet guide vane to modulate the thrust of a high bypass turbofan engine was evaluated at altitude/Mach number conditions of 4572 m/0.6 and 9144 m/0.93. Fan-tip, gas generator and supercharger performance were also determined, both on operating lines and during fan duct throttling. The evaluation was repeated with the bypass splitter extended forward to near the fan blade trailing edge.

Gross thrust attenuation of over 50 percent was achieved with 50° VIGV closure at 100 percent corrected fan speed. Gas generator supercharger performance fell off with VIGV closure, but this loss was reduced when a splitter extension was added. The effect of VIGV closure on gas generator performance was minimal.

Nomenclature

D	duct diameter
ETA <sub>FH2C</sub>	fan-hub efficiency measured from engine inlet to core inlet
ETA <sub>FT</sub>	fan-tip efficiency
F <sub>PRH2C</sub>	fan-hub pressure ratio measured from engine inlet to core inlet
F <sub>PRT</sub>	fan-tip pressure ratio
N <sub>F</sub> /√θ <sub>2</sub>	fan speed corrected to engine inlet temperature, percent of 7005 rpm
N <sub>G</sub> /√θ <sub>2C</sub>	gas generator speed corrected to core inlet temperature, percent of 15 683 rpm
PS	static pressure, kPa
PT	total pressure, kPa
PT <sub>2</sub>	engine inlet pressure, kPa
PT <sub>2C</sub>	gas generator inlet pressure, kPa
S/G	strain gage
TM	metal temperature, K
TT	total temperature, K
VIGV	variable inlet guide vane
W <sub>A1</sub>	total engine inlet airflow, kg/sec
W <sub>A2C</sub>	core inlet airflow, kg/sec
W <sub>A<sub>T</sub></sub>	fan-tip airflow, W <sub>A1</sub> -W <sub>A2C</sub> , kg/sec
WF	fuel flow, kg/hr
α	VIGV angle, deg
δ	ratio of total pressure to absolute pressure of NASA standard sea-level conditions
θ	ratio of total temperature to absolute temperature of NASA standard sea-level conditions
Subscripts:	
BL	boundary layer

\*Research Engineer; Member AIAA.  
\*\*Research Engineer.

2 engine inlet  
2C gas generator inlet

Introduction

The propulsion system of a V/STOL aircraft must provide substantial and rapid thrust modulation to control attitude, especially during take-off, landing, and hover. In a high bypass turbofan, most thrust is developed in the fan tip, therefore variable inlet guide vanes, controlling the airflow into a fan, have been proposed as one means for achieving this modulation.

Performance of a variable inlet guide vane fan has previously been demonstrated on rig tests (refs. 1 and 2) and on a full-scale engine test (ref. 3). In these tests, however, the VIGV covered the entire annulus ahead of the fan, thus as fan-tip performance decreased with VIGV closure, so did gas generator supercharging. In a two-engine VTOL aircraft, the gas generator size is determined by a one-engine inoperative vertical landing requirement where one core engine must drive both fans. Thus decreased core supercharging due to full-span VIGV's would necessitate an increased core engine size. A part-span VIGV, the subject of this paper, would maintain core supercharging. In addition, a forward extension of the fan/core bypass splitter was tested to investigate its potential for further improving core supercharging.

The evaluation reported herein was conducted in the NASA Lewis Research Center PSL altitude chamber at simulated flight conditions of 4572 m (15 000 ft) altitude, 0.6 Mach number with 284 K (511° R) inlet temperature, and at 9144 m (30 000 ft) altitude, 0.93 Mach number with both 284 and 259 K (466° R) inlet temperatures.

Apparatus

Engine and Installation

A YTF34-F5 high bypass turbofan, configured to closely resemble a TF34-100 engine, was used in this evaluation. At the design point, the fan pressure ratio was 1.5:1, the total airflow was 151 kg/sec (333 lb/sec), the bypass ratio was 6.2:1, and the core compressor pressure ratio was 14:1. Design point thrust was 40 000 newtons (9000 lb). A detailed description of the engine may be found in reference 4. The engine was installed in a conventional direct-connect manner with a labyrinth seal isolating the inlet ducting from the test chamber. A photograph of the installation is provided in figure 1. The engine was mounted on a thrust bed suspended from the

test chamber by four long flexure rods. The outer fan cowl and convergent fan and core exhaust nozzles were extended to provide a nearly coplanar exhaust. The core nozzle exit area was 1258 cm<sup>2</sup> (195 in<sup>2</sup>). The fan had two possible nozzles, a "nominal" nozzle with an exit area of 4640 cm<sup>2</sup> (719 in<sup>2</sup>) and a large nozzle having an exit area of 5670 cm<sup>2</sup> (879 in<sup>2</sup>).

A fan back-pressure system (fig. 2) was installed for portions of the test when fan characteristic curves between a nominal operating line and a limit line were being determined (ref. 5). When this large structure was mounted on the thrust bed, thrust data were not recorded.

#### Variable Inlet Guide Vane and Extended Splitter

The part-span VIGV evaluated in this program is shown in figures 3 and 4. The assembly consisted of 30 fixed forward struts, cantilevered from an outer casing and mutually supported by a fixed inner ring, and 30 movable rear flaps. The undeflected VIGV was completely uncambered and was intended to produce nominal TF34 performance. A detailed description of the VIGV design was given in reference 3.

The extended splitter configuration is shown in figure 5. This splitter provided an aerodynamically shaped physical boundary between the fanhub and tip flows from immediately behind the fan trailing edge, rearward to the core inlet splitter. Its purpose was to reduce spillage of fanhub airflow over the splitter and thus maintain fanhub performance.

#### Instrumentation

The instrumentation used to acquire the data to be presented is shown in figure 6. As this figure indicates, the airflow measurement station, the fan inlet and exit, and the gas generator inlet and exit were heavily instrumented. Pressures were recorded on individual transducers and on scanivalves. The differential pressure scanivalve transducers were calibrated on each data scan. Temperatures were measured on either ChromelAlumel or copper-constantan thermocouples referenced to 339 K (610° R).

Stress levels in the VIGV, fan blades, fan exit guide vanes, and compressor third-stage starters were monitored using strain gages. A photoelectric scan system (ref. 6) was also used to monitor fan blade vibrations.

#### Procedure

For this evaluation, the average engine inlet total pressure and total temperature, and the test chamber altitude pressure, were maintained at values corresponding to a simulated Mach number of 0.6 at 4572 m (15 000 ft) altitude with an inlet total temperature of 284 K (511° R), or at a simulated Mach number of 0.93 at 9144 m (30 000 ft) altitude with inlet total temperatures of 284 K (511° R) or 259 K (466° R). The low inlet pressures were chosen to reduce stress levels on the test hardware. The lower inlet temperature was selected to permit running at higher speeds while avoiding turbine temperature limits.

Tests were run in two phases. Performance data, with thrust measurement, were recorded on the nominal and low (large fan nozzle) operating lines at VIGV closures of 0°, 15°, 35°, and 50°. Then, the fan back-pressure jets were installed and data were recorded along lines of constant fan

speed from the operating line to an aeromechanical or aerodynamic limit. No thrust data were recorded during the fan mapping tests. These procedures were followed for the baseline TF34 with VIGV's and also for the TF34 with VIGV's and the extended splitter.

It should be noted that excess fan-turbine power, due to fan unloading with VIGV closure, was not extracted and so did not simulate many typical V/STOL load requirements. Therefore, to maintain a constant fan speed, it was expected that the core speed, and therefore the throttle position, would have to be reduced as the VIGV closed.

### Results and Discussion

#### Effect of VIGV on Thrust and Fan Performance

The objective of installing variable inlet guide vanes ahead of a high bypass turbofan engine was to investigate thrust modulation and engine performance changes due to the VIGV's. Figure 7 shows the measured attenuation of gross thrust with VIGV closure at 4572 m altitude, 0.6 Mach number. At 100 percent corrected fan speed, closing the VIGV from 0° to 50° decreased thrust from 34 700 newtons (7800 lb) to 15 790 newtons (3550 lb), more than a 50-percent thrust drop. The part-span VIGV was designed to achieve this modulation by reducing the fan-tip airflow, which comprised more than 85 percent of the total inlet flow, with minimal effect in the fan-hub region.

The effect of the VIGV on fan performance at 95 percent corrected fan speed,  $N_f/\sqrt{\theta_2}$ , can be seen in figure 8. As the VIGV closed from 0° to 50°, the constant speed line dropped, providing a reduced pressure ratio and airflow characteristic. Fan-tip efficiency decreased as the VIGV closed beyond 15° with a dramatic loss between 35° and 50°.

In no case was a fan stall encountered. At 0° and 15° VIGV, fan flutter modes limited operation. At 35° and 50°, fan exit guide vane stresses, due to EGV stall, were limiting. These were also the limits encountered at other speeds with the standard bypass splitter. More information on these aeromechanical limits can be found in reference 7.

Gas generator supercharging by the fan-hub and through the gooseneck is presented in figure 9 in terms of the ratio of core inlet pressure to engine inlet pressure, efficiency, and gas generator inlet airflow corrected to the engine inlet conditions. As the VIGV closed, the supercharger pressure ratio and efficiency curves shifted to lower airflow, pressure ratio, and efficiency, with a large performance loss between 35° and 50°. Note that on these data as the fan-tip was back-pressured, both the pressure ratio and corrected airflow increased for the supercharger, which was not throttled, helping to satisfy the increased power demand put on the core engine during fan duct throttling.

Fan-tip performance with the extended splitter is shown in figure 10. Along lines of constant fan speed, the fan-tip pressure ratio and airflow began at lower values than with the standard splitter. Even the curves for 0° VIGV are not colinear. This is believed to be due to the extended splitter imposing one fixed fan exit area split which is not optimal for all speeds and airflows. As the fan-tip was throttled, the characteristic for 0° VIGV gradually merged with its standard splitter counterpart. At 15° and greater VIGV closures, the characteristics with the exten-

ded splitter crossed the standard splitter curves, and encountered limits at higher fan tip pressure ratios. With the extended splitter, fan flutter modes generally determined the limit during fan back pressuring.

Fan-tip efficiency curves for both splitters nearly coincided at 0° and 15° VIGV. At larger closures, the fan-tip efficiency with the extended splitter was lower at high flows, but rose and stayed above the efficiency with the standard splitter, as fan flow was throttled.

Supercharging performance with the extended splitter (fig. 11) was higher than with the standard splitter. At each VIGV angle, both pressure ratio and efficiency showed improvement, which, while small at lesser VIGV angles, became considerable beyond 35°.

The improved fan-hub supercharging performance can be seen in more detail in figure 12 and table I which compare the pressure profiles at the core inlet for VIGV at 35° and several resulting performance parameters for both splitter cases. The data were recorded at the same speed, core airflow, and engine inlet conditions, however, several differences appear. The average core inlet pressure with the standard splitter, 63.0 kPa (9.13 psia), was significantly lower than with the extended splitter, 68.5 kPa (9.93 psia), with a resulting difference in supercharging pressure ratio of 1.201 against 1.295. Also, the total pressure profiles for the standard splitter case are steeper than those for the extended splitter, imposing a larger hub-radial distortion on the core engine. Even the radial static pressure gradients are less severe with the extended splitter.

It is believed that in applications in which fan power is extracted as the VIGV closes, requiring that core speed be maintained, the supercharger losses would be lowered further. This is because maintaining core airflow should decrease those losses due to diffusion of a portion of the fan-hub flow into the fan-duct.

#### Effect of VIGV on Gas Generator Performance

As the VIGV closed and unloaded the fan, excess power became available from the fan turbine. In order to maintain a constant fan speed, the throttle position, and therefore the core speed, were reduced. This is seen in figure 13 where the corrected core speed-fan speed match is presented for operating lines at the 4572 m/0.6 Mach number condition. The drop in core speed at 100 percent corrected fan speed was 5 percent as the VIGV closed from 0° to 15°, 4 percent from 15° to 35°, and 1 percent from 35° to 50°. With the extended splitter, it was necessary to reduce core speed even lower than with the standard splitter, due to improved core supercharging.

The core compressor remained on its nominal operating line. The only effect of VIGV closure on compressor performance was to move the operating point lower along the operating line due to the speed reduction previously shown in figure 13. In figure 14, the compressor operating line for the extended splitter appears to fall slightly below that with the standard splitter.

The effect of VIGV closure on fuel flow rate may be seen in figure 15. As the preceding would imply, less energy input was required to maintain a constant fan speed as the VIGV closed. The fan-tip unloading and gas generator deceleration as the VIGV's closed at a fixed fan speed decreased the energy demands of the engine. With

the extended splitter and its improved core supercharging and greater core speed drop the fuel consumption was even lower.

#### Summary of Results

An experimental investigation was performed to evaluate the concept of using a part-span variable inlet guide vane to modulate the thrust of a high bypass turbofan engine with minimal effect on gas generator supercharging. Forward extension of the bypass splitter was also evaluated as a means of further eliminating supercharger losses. The major results of this investigation follow.

- o Deflecting part-span variable inlet guide vanes provided a high degree of thrust modulation, largely through the modulation of fan-tip performance. A reduction of gross thrust greater than 50 percent was demonstrated at a constant fan speed for a 6:1 bypass ratio engine.
- o The supercharger did suffer performance losses as the VIGV closed, especially at the larger VIGV angles. These larger losses were substantially reduced by extending the bypass splitter forward. Thus, the extended splitter becomes an important consideration when thrust modulation requires large VIGV closures.
- o The core compressor stayed on its operating line regardless of what was done to the fan. The core operating line was slightly lower with the extended splitter.
- o The gas generator supercharging was influenced by both the fan-tip and the gas generator demands.
- o As the fan was unloaded with VIGV closure, excess power became available from the fan turbine. Therefore, to maintain a constant fan speed, the gas generator had to be decelerated by decreasing fuel flow.

In summary, the installation of a part-span variable inlet guide vane system ahead of a high bypass turbofan engine appears to be a feasible method of accomplishing the thrust modulation required for V/STOL attitude control.

#### References

1. Moore, R. D. and Reid, L., "Aerodynamic Performance of Axial-Flow Fan Stage Operated at Nine Inlet Guide Vane Angles," NASA TP-1510, 1979.
2. Healy, H. S., "V/STOL Performance Comparisons with Variable Pitch and Variable Inlet Guide Vane Fans: A Report on Experimental Data," AIAA Paper 79-1286, June 1979.
3. Reed, V. L. and Schneider, P. W., "Part-Span Variable Inlet Guide Vanes for V/STOL Fan Thrust Modulation," AIAA Paper 80-1248, June 1980.
4. "TF34-100 Training Guide," General Electric Company, Aircraft Engine Group, Lynn, MA, SEI-451, Feb. 1978.
5. Biesiadny, T. J., "Test Techniques for Obtaining Off-Nominal Compressor Data During Engine Tests," NASA TM X-71597, 1974.
6. Neiberding, W. C. and Pollack, J. L., "Optical Detection of Blade Flutter," ASME Paper 77-GT-66, Mar. 1977.
7. Lubomski, J. F., "Status of NASA Full-Scale Engine Aeroelasticity Research," NASA TM-81500, 1980.

TABLE I

VIGV	35°	35°
Splitter	Standard	Extended
PT2	52.40 kPa	52.88 kPa
NF/√a <sub>2</sub>	95.0 percent	95.1 percent
WA1√a <sub>2</sub> /δ <sub>2</sub>	120.4 kg/sec	118.0 kg/sec
WAT√a <sub>2</sub> /δ <sub>2</sub>	109.2 kg/sec	106.8 kg/sec
WA2C√a <sub>2</sub> /δ <sub>2</sub>	11.2 kg/sec	11.1 kg/sec
PT2C	63.0 kPa	68.5 kPa
FPRT	1.150	1.110
ETAFT	0.790	0.704
FPRH2C	1.201	1.295
ETAFH2C	0.513	0.697
NG/√a <sub>2C</sub>	90.5	88.5

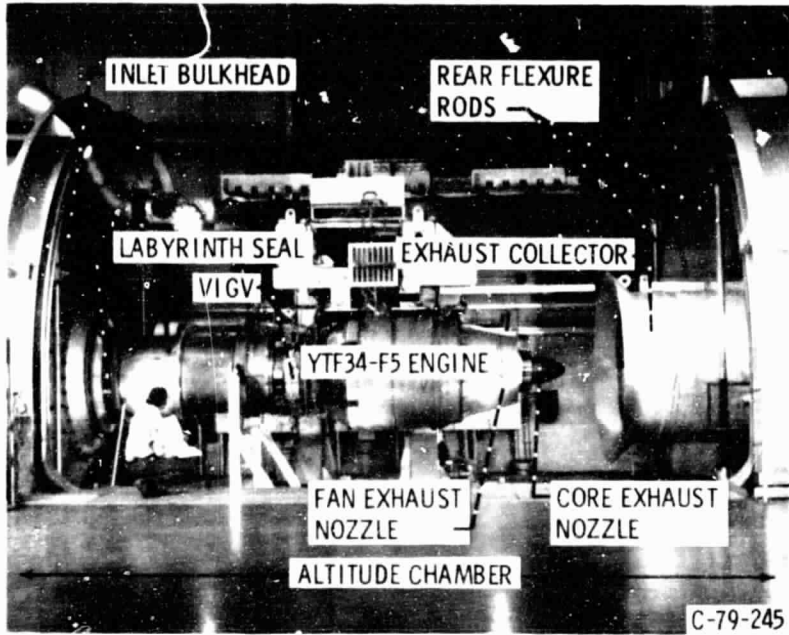

Figure 1. - TF-34 engine, with VIGV, installed in altitude facility.

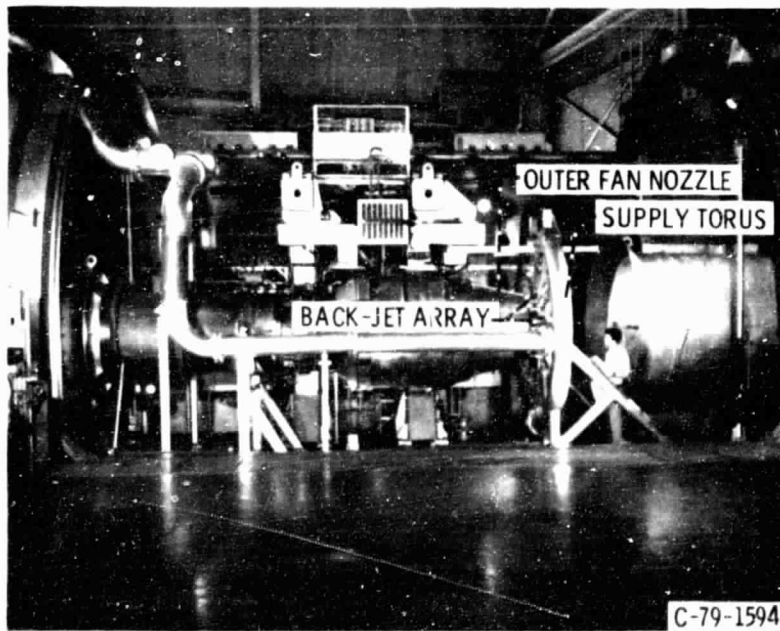

Figure 2. - Fan back-pressure system installation.

50  
 100  
 150  
 200  
 250  
 300  
 350  
 400  
 450  
 500  
 550  
 600  
 650  
 700  
 750  
 800  
 850  
 900  
 950  
 1000

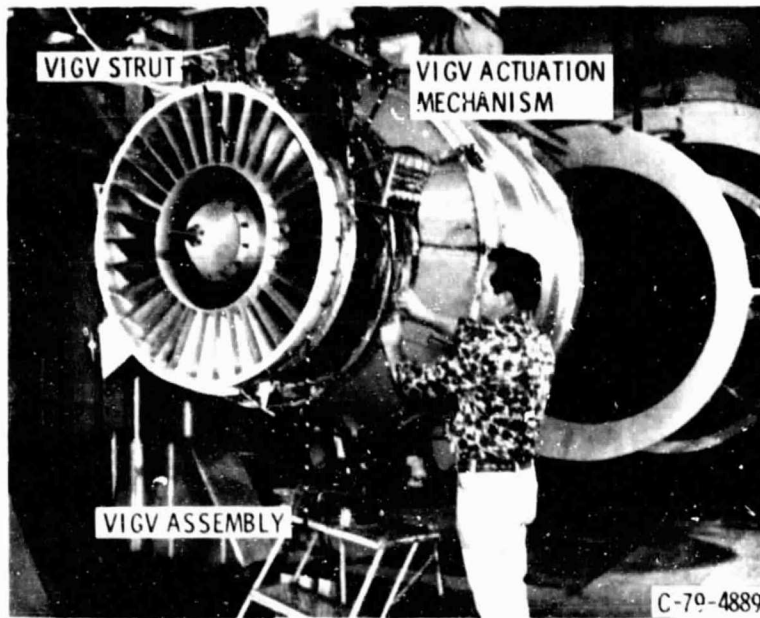

Figure 3. - Part-span VIGV installed on YTF34-F5 engine.

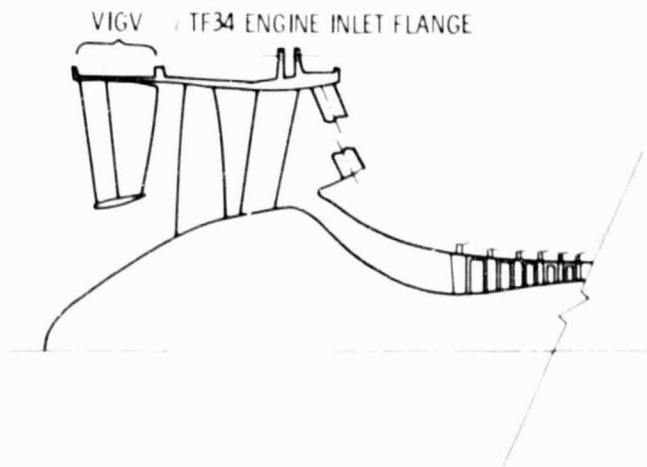

Figure 4. - Cross-section of VIGV installed ahead of TF34 turbfan engine.



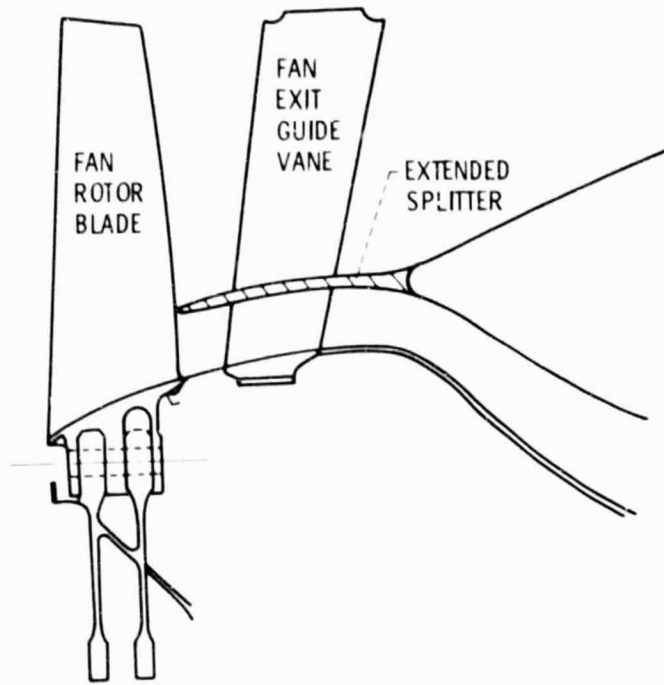

Figure 5. - Cross-section of extended splitter installation.

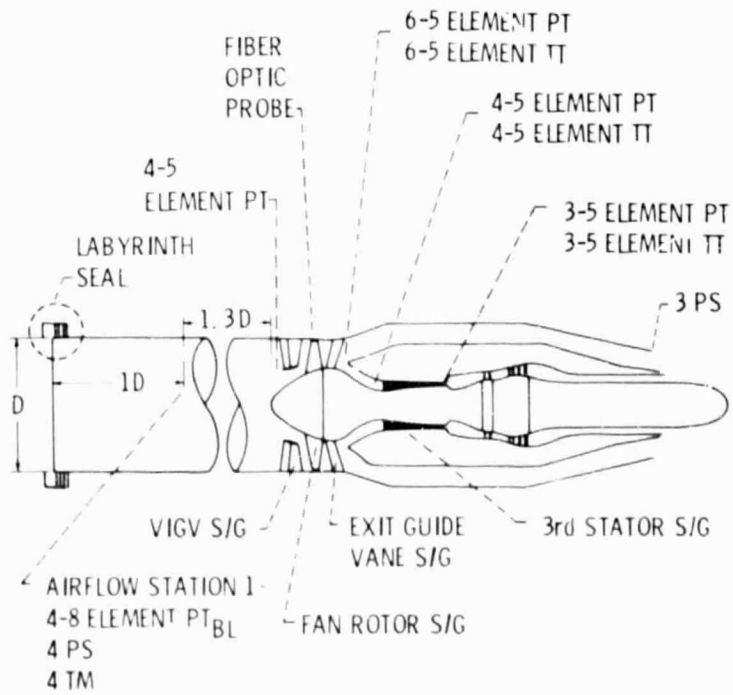

Figure 6. - Schematic of TF34 installation, instrumentation and VIGV.

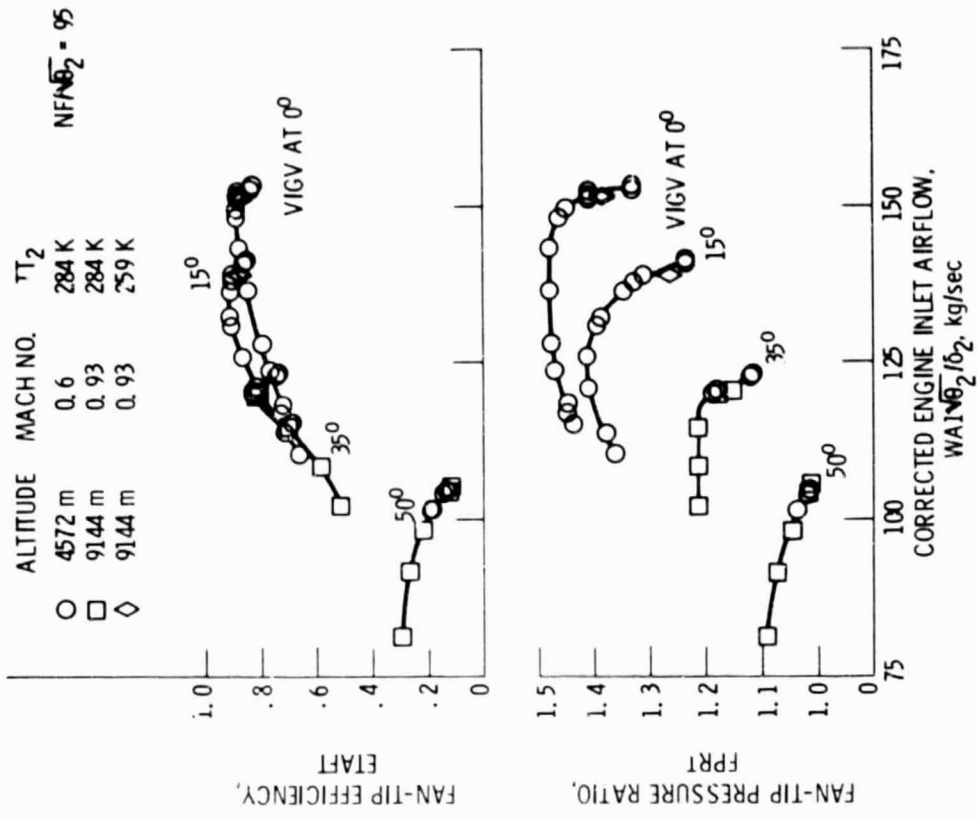

Figure 8. - Effect of VIGV closure on fan-tip performance with standard bypass splitter.

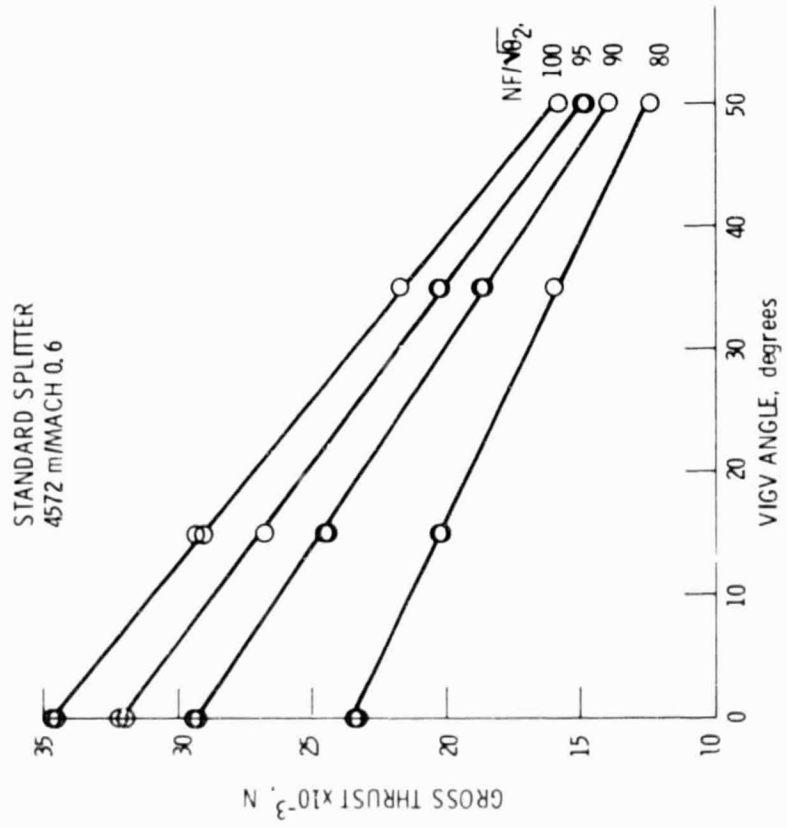

Figure 7. - VIGV attenuation of gross thrust

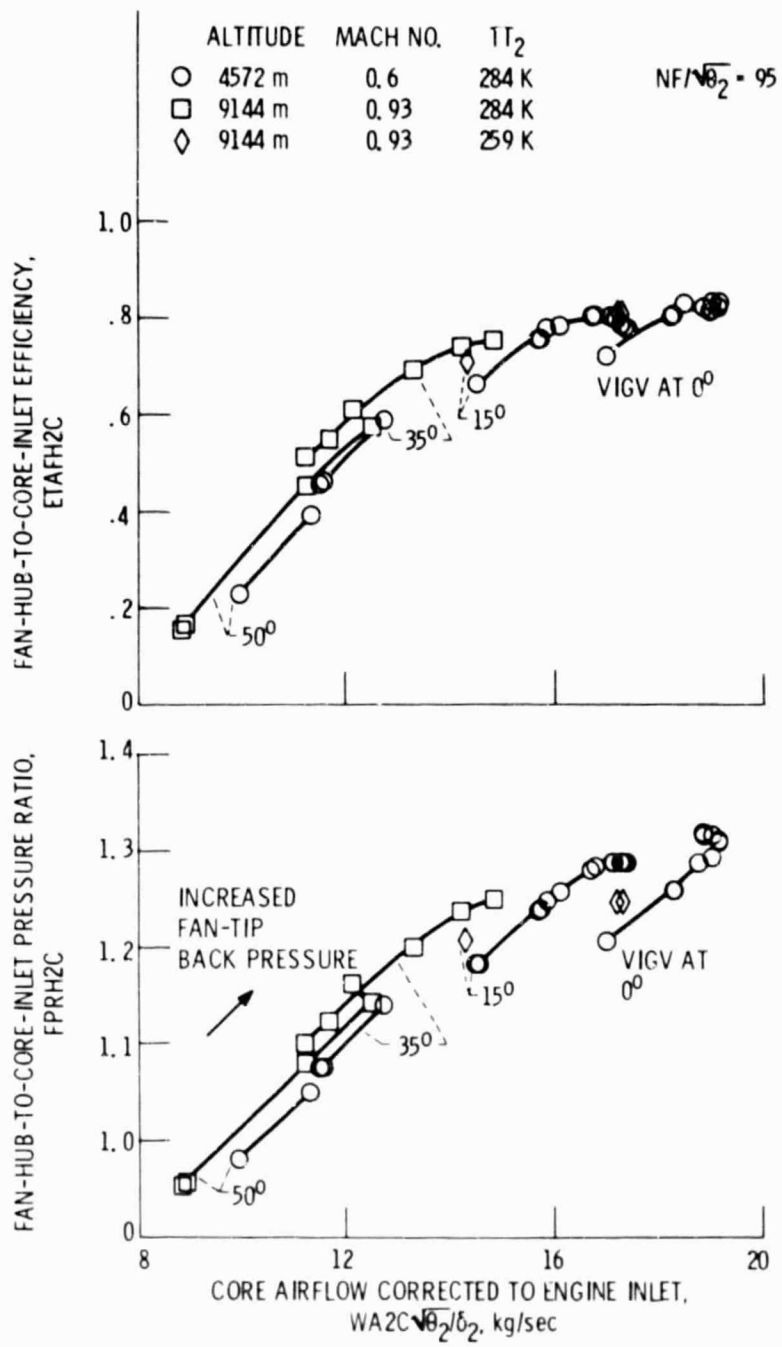

Figure 9. - Effect of VIGV closure on supercharger performance with standard bypass splitter.

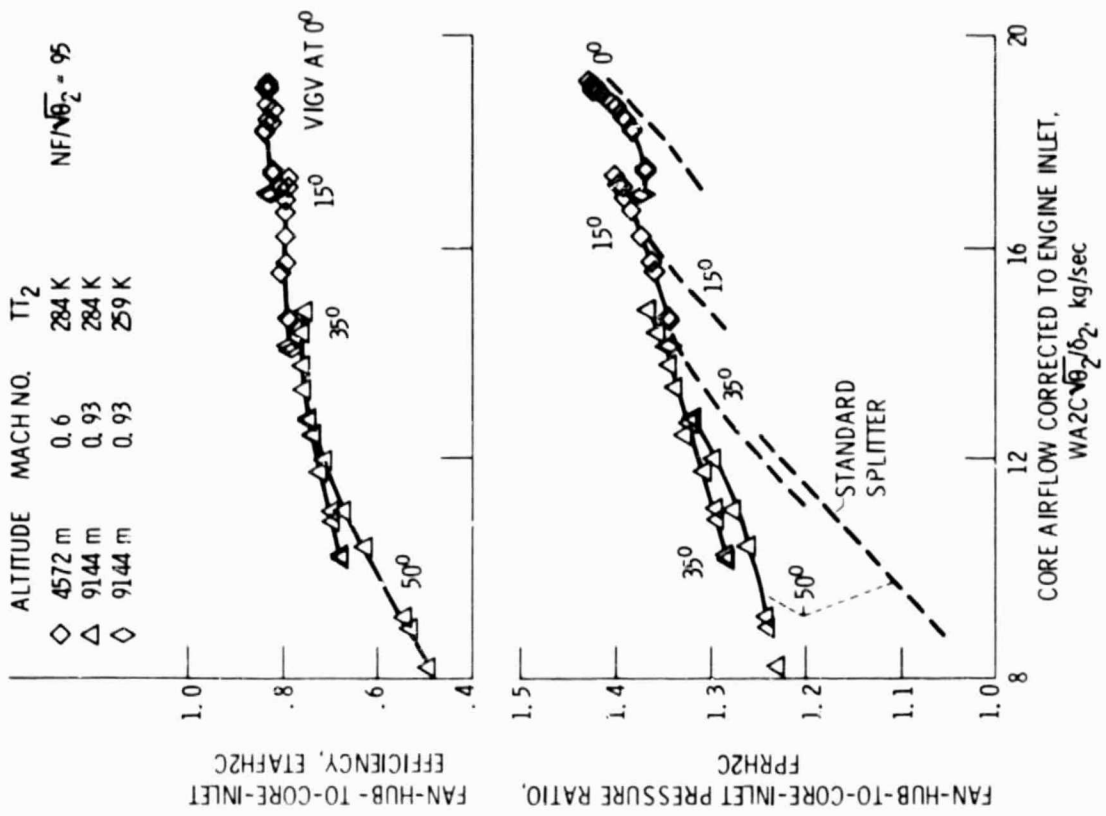

Figure 11. - Effect of VIGV closure on supercharger performance with extended bypass splitter.

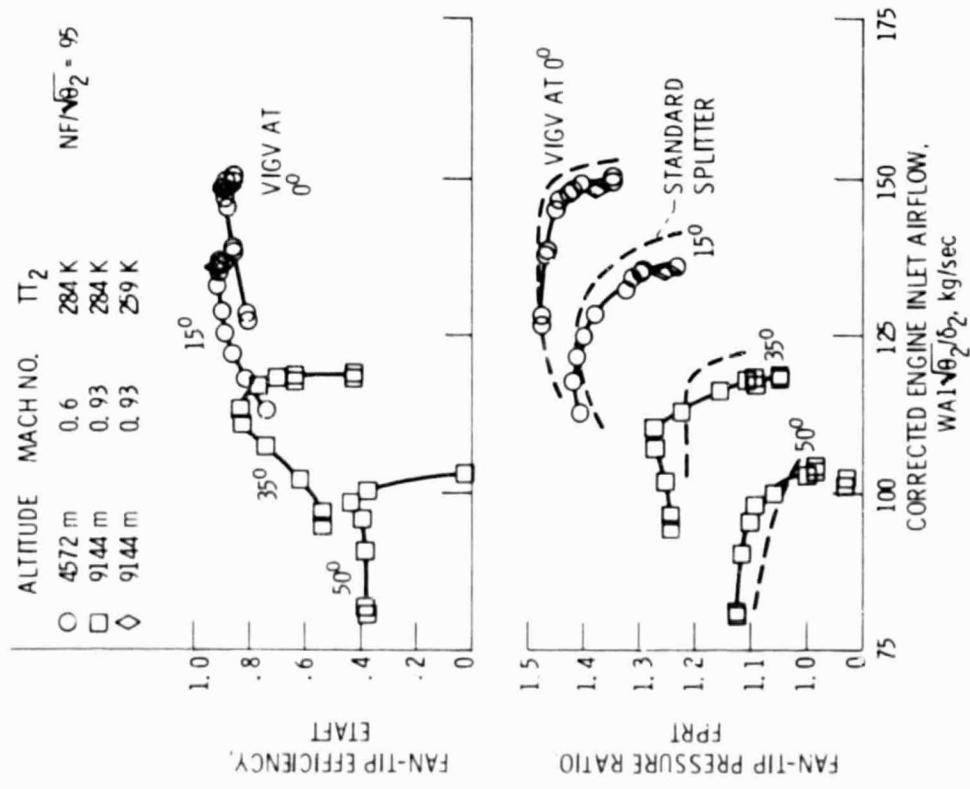

Figure 10. - Effect of VIGV closure on fan-tip performance with extended bypass splitter.

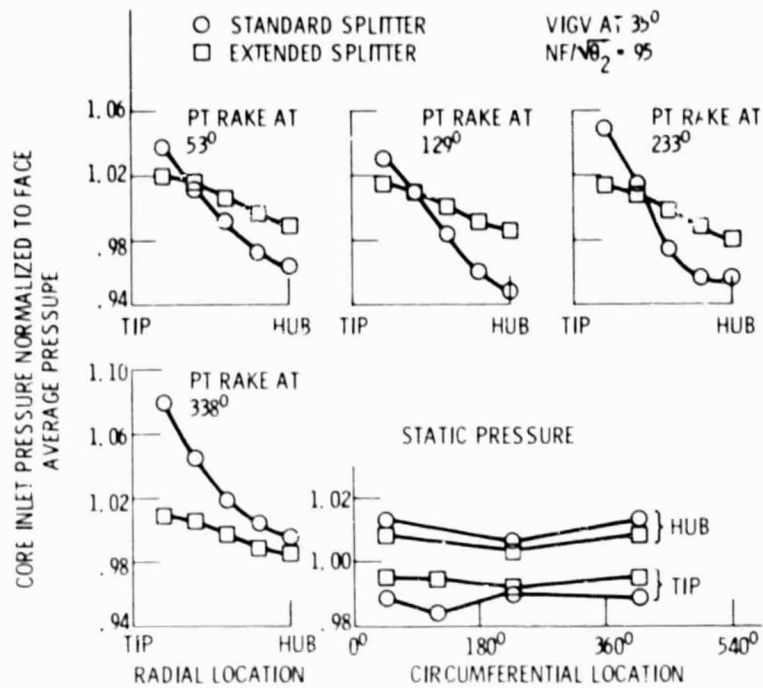

Figure 12. - Effect of extended splitter on core-inlet pressure profiles at 9144 m/Mach 0.93.

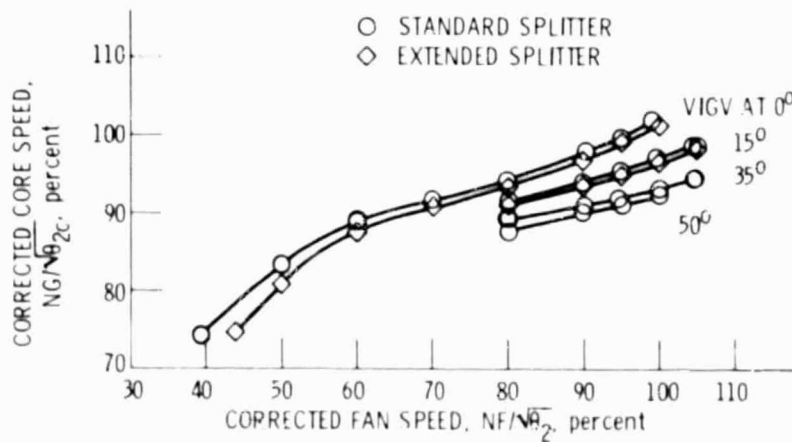

Figure 13. - Effect of VIGV and bypass splitter on engine speed match on nominal operating lines at 4572 m/Mach 0.6.

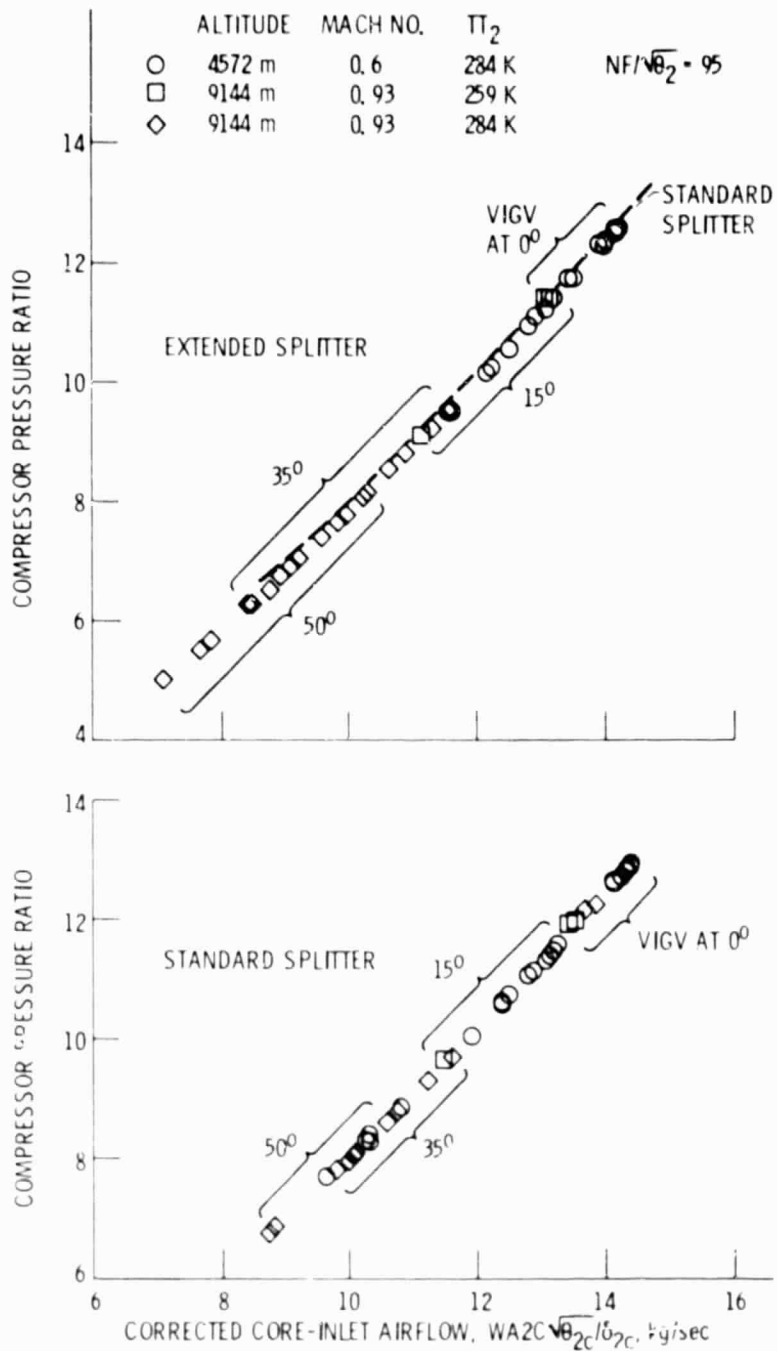

Figure 14. - Effect of VIGV and bypass splitter on compressor performance.

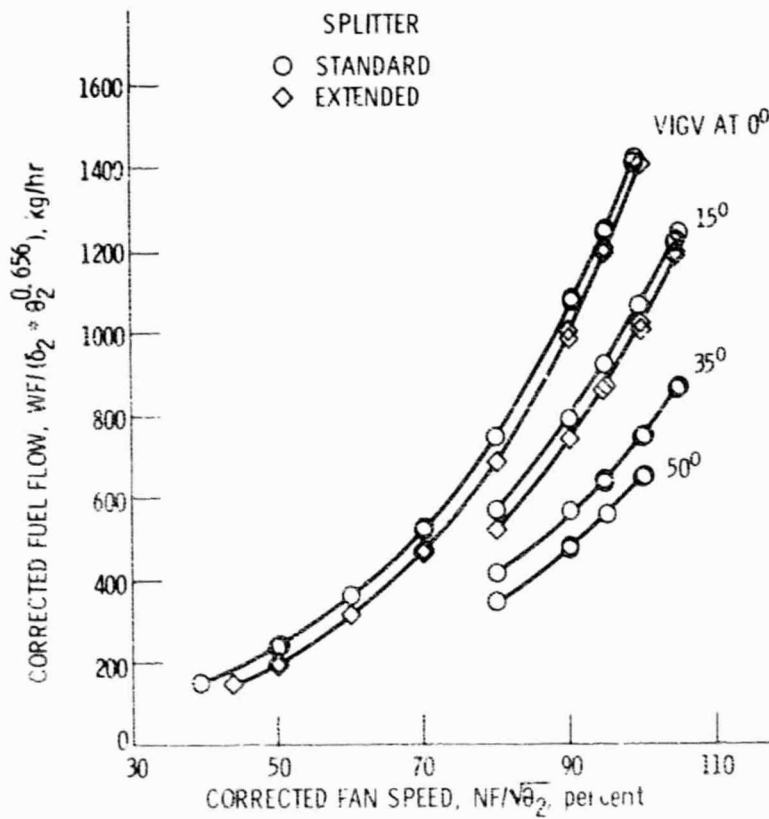

Figure 15. - Effect of VIGV and bypass splitter on corrected fuel flow on the operating line at 4572 m/Mach 0.6.