



NASA CR-159,010

NASA Contractor Report 159010

NASA-CR-159010
19810018578

747 PRIMARY FLIGHT CONTROL SYSTEMS RELIABILITY AND MAINTENANCE

ENERGY EFFICIENT TRANSPORT PROGRAM

BOEING COMMERCIAL AIRPLANE COMPANY,
P.O. BOX 3707, SEATTLE, WA 98124

CONTRACT NAS1-14742, TASK 4.6
APRIL 1979

~~_____~~

Because of its possible commercial value, this data developed under U.S. Government contract NAS1-14742 is being disseminated within the U.S. in advance of general publication. This data may be duplicated and used by the recipient with the expressed limitations that the data will not be published nor will it be released to foreign parties without prior permission of The Boeing Company. Release of this data to other domestic parties by the recipient shall only be made subject to these limitations. The limitations contained in this legend will be considered void after April 1981. This legend will be marked on any reproduction of this data in whole or in part.

~~_____~~

NASA

National Aeronautics and
Space Administration

Langley Research Center
Hampton, Virginia 23665
AC 804 827-3966

RECEIVED

MAY 1 1980

LANGLEY RESEARCH CENTER
LIBRARY, NASA
HAMPTON, VIRGINIA



FOREWORD

This document constitutes the final report for task 4.6, "747 Primary Flight Control Systems Reliability and Maintenance Study," one of five major tasks covered by the statement of work for contract NAS1-14742. The report covers work conducted from August 1977 through July 1978. The NASA technical monitor for all contract tasks was D.B. Middleton of the Energy Efficient Transport project office at Langley Research Center.

The investigations were conducted within the Product Assurance unit of the Vice President—Engineering organization of Boeing Commercial Airplane Company. Contractor personnel who participated and their areas of contribution are:

G.W. Hanks	Program Manager
G.T. Katt	Task Manager
R.H. Edwards	Principal Investigator
R.D. Shannon	Reliability Modeling

Principal measurements and calculations used during this study were in customary units.

N79 - 75742#



CONTENTS

	Page
1.0 SUMMARY	1
2.0 INTRODUCTION	3
2.1 Study Objective	3
2.2 Primary Flight Control System Definition	3
2.3 Reliability Analysis Approach	4
2.4 Maintenance Cost Approach	4
2.5 Report Structure	5
3.0 SYMBOLS AND ABBREVIATIONS	7
4.0 STUDY RESULTS	9
4.1 Description of Model 747 Systems	9
4.1.1 Elevator Control	10
4.1.2 Stabilizer Trim	16
4.1.3 Lateral Control	23
4.1.4 Rudder Control	31
4.1.5 Speed Brakes	38
4.1.6 Hydraulic Power Supply	41
4.1.7 Electrical Power Supply	41
4.2 Reliability Assessment	44
4.2.1 Analysis Methodology	44
4.2.2 Control Function Definition	49
4.2.3 Component Reliability	51
4.2.4 Control Function Analysis	65
4.2.5 PFCS Analysis and Sensitivity	95
4.3 Maintenance Cost Assessment	100
4.3.1 Scheduled Line Maintenance Cost	102
4.3.2 Unscheduled Line Maintenance Cost	103
4.3.3 Overhaul Shop Maintenance Cost	105
4.3.4 Delay and Cancellation Costs	106
4.3.5 Maintenance Cost Summary	108
5.0 CONCLUDING REMARKS	111
5.1 Control Function Reliability	111
5.2 Maintenance Cost Assessment	112
6.0 REFERENCES	113
APPENDIX A CARSRA Program Description and Users Guide	A-1 thru A-31
APPENDIX B Airline Component Removal Details	B-1 thru B-25
APPENDIX C Power Control Unit Workshop Findings	C-1 thru C-8
APPENDIX D 747 Hydraulic System Fluid Losses	D-1 thru D-5
APPENDIX E Scheduled Maintenance Requirements	E-1 thru E-12
APPENDIX F Delay/Cancellation Cost Algorithm	F-1 thru F-6

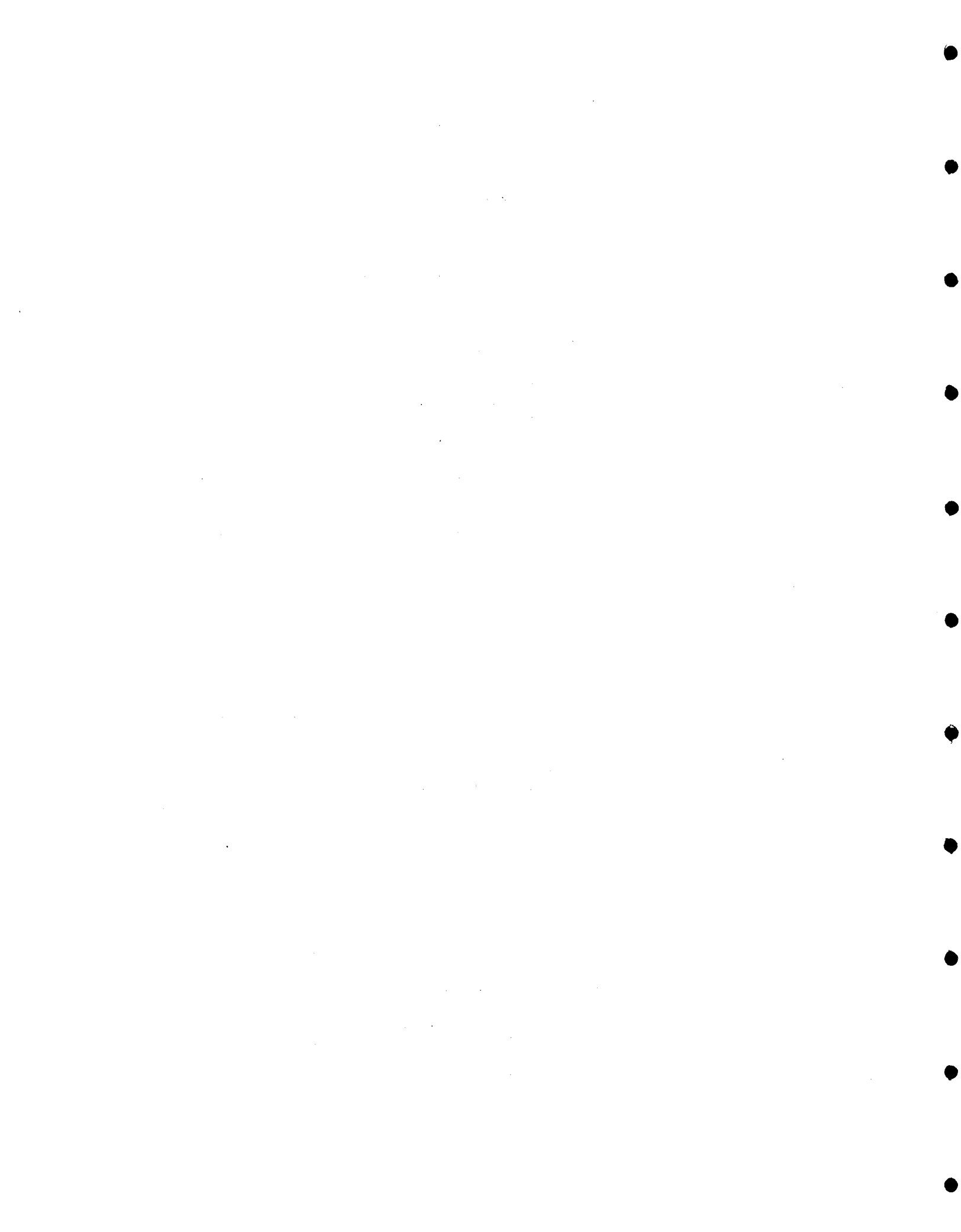

FIGURES

No.		Page
1	747 Control Surface Location	9
2	Elevator Control System	11
3	Elevator Feel System	12
4	Inboard Elevator Power Control Unit	13
5	Elevator Control Functional Block Diagram	14
6	Elevator Control Reliability Block Diagram	15
7	Stabilizer Trim System	17
8	Stabilizer Trim Control Modules	19
9	Stabilizer Trim Drive Mechanism	20
10	Stabilizer Trim Functional Block Diagram.	21
11	Stabilizer Trim Reliability Block Diagram	22
12	Lateral Control System	24
13	Central Control Inputs	25
14	Central Control Actuator Schematic	27
15	Aileron Power Control Unit	28
16	Spoiler Quadrant Schematic	39
17	Lateral Control Functional Block Diagram	30
18	Lateral Control Reliability Block Diagram	31
19	Rudder Control System	32
20	Rudder Trim System	33
21	Rudder Ratio Changer System	34
22	Rudder Power Control Unit	35
23	Rudder Control Functional Block Diagram	36
24	Rudder Control Reliability Block Diagram	37
25	Speed Brake System	38
26	Speed Brake Functional Block Diagram	39
27	Speed Brake Reliability Block Diagram	40
28	Flight Control Hydraulic System	42
29	Electrical Power System	43
30	System Modeling for CARSRA Program	44
31	Computer Control System Model	46
32	Mechanical Control System Model	47
33	Functional Failure Rate Determination	52
34	Electrical Power Fault Tree	56
35	CARSRA Modeling Process	65
36	Markov Model with Different Modules	66
37	Elevator Control State Identification	66
38	Elevator Control Dependency Tree	67
39	Elevator Control Markov Models	68
40	Elevator Control Success Path Model	73
41	Stabilizer Trim Stage Identification	74
42	Stabilizer Trim Dependency Tree	75
43	Stabilizer Trim Markov Models	76
44	Lateral Control Stage Identification	80
45	Lateral Control Dependency Tree	81
46	Lateral Control Markov Models	82
47	Lateral Control Markov Models for Outboard Ailerons	84

No.		Page
48	Rudder Control Stage Identification	86
49	Rudder Control Dependency Tree	87
50	Rudder Control Markov Models	88
51	Rudder Control Success Path Model	90
52	Speed Brake Stage Identification	91
53	Speed Brake Dependency Tree	92
54	Speed Brake Markov Models	93
55	PFCS Dependency Tree	95
56	PFCS Markov Models	99
57	PFCS and Airframe Maintenance Cost	109

TABLES

No.		Page
1	Control Function Definitions	50
2	PFCS Function Definition	50
3	Summary of Airline Component Removal Rates	53
4	Electrical Power Component Failure Rates	55
5	Functional Failure Rate Summary	64
6	Elevator Control Stage Failures	71
7	Elevator Control Module Dependencies	71
8	Elevator Control Stage Success Configurations	72
9	Elevator Control Failure Probabilities	72
10	Elevator Control Functional Readiness	72
11	Stabilizer Trim Stage Failures	77
12	Stabilizer Trim Module Dependencies	77
13	Stabilizer Trim Stage Success Configurations	78
14	Stabilizer Trim Failure Probabilities	78
15	Stabilizer Trim Functional Readiness	78
16	Lateral Control Stage Failures	79
17	Lateral Control Module Dependencies	79
18	Lateral Control Stage Success Configurations	83
19	Lateral Control Failure Probabilities	83
20	Lateral Control Functional Readiness	84
21	Lateral Control Stage Failures (Low-Speed Case)	84
22	Rudder Control Stage Failures	85
23	Rudder Control Module Dependencies	85
24	Rudder Control Stage Success Configurations	85
25	Rudder Control Failure Probabilities	89
26	Rudder Control Functional Readiness	89
27	Speed Brake Stage Failures	91
28	Speed Brake Module Dependencies	92
29	Speed Brake Stage Success Configurations	93
30	Speed Brake Failure Probabilities	94
31	Speed Brake Functional Readiness	94
32	PFCS Stage Failures	96
33	PFCS Module Dependencies	97
34	PFCS Stage Success Configurations	97
35	PFCS Failure Probabilities	97
36	PFCS Functional Readiness	98
37	PFCS Input and Actuation Failure Probabilities	99
38	Direct Maintenance Cost Categories	102
39	Scheduled Maintenance Man-Hours	103
40	Line Maintenance Man-Hours	104
41	Unscheduled Line Maintenance Costs	104
42	Overhaul Shop Maintenance Costs	106
43	Delay and Cancellation Rates for 747 Fleet During 1977	107
44	Delay and Cancellation Costs	108
45	Maintenance Cost Summary	108
46	Failure Probability of Each Control Function for a 4-hr Flight	111
47	Total PFCS Unscheduled Maintenance Cost	112

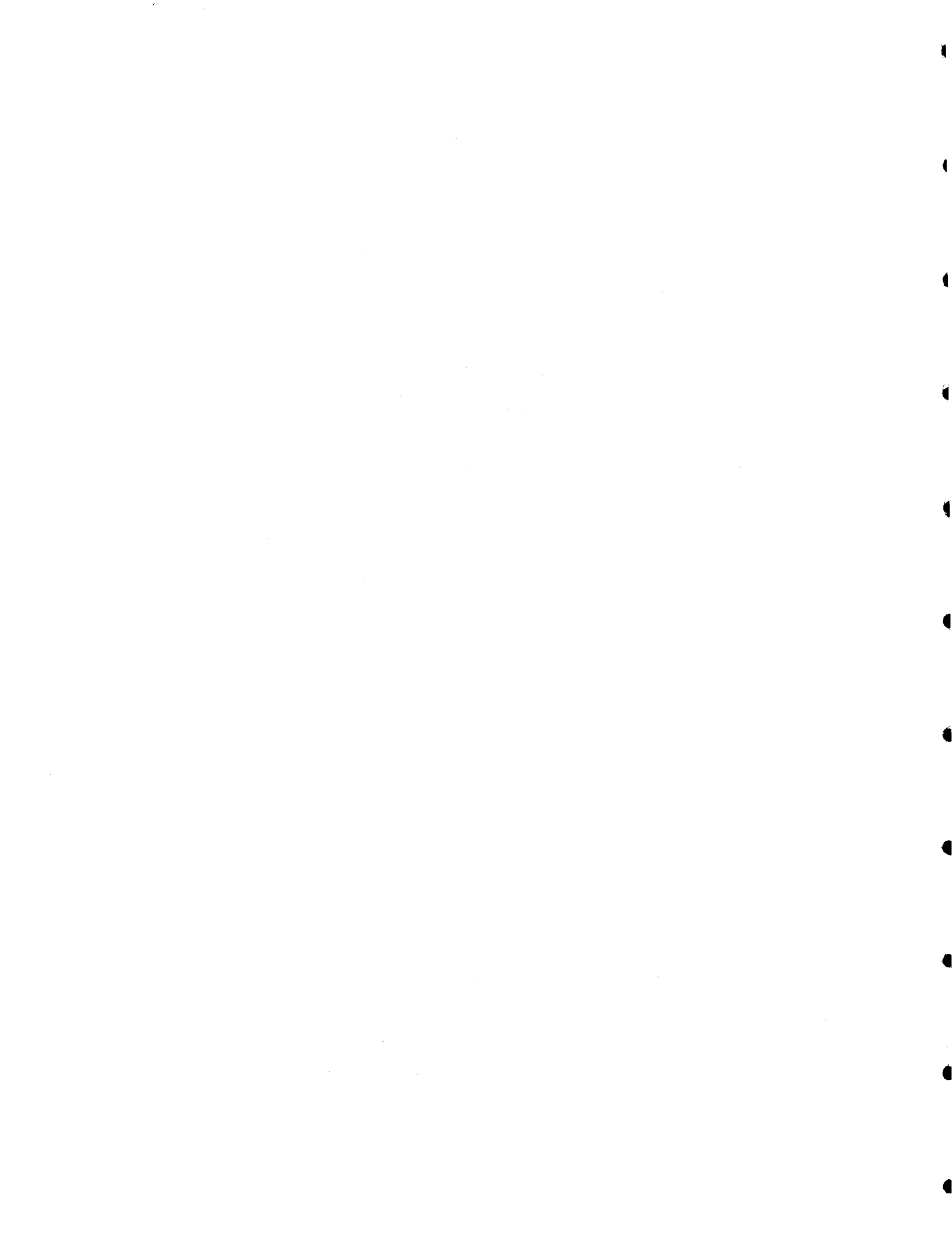

1.0 SUMMARY

The Boeing model 747 primary flight control system (PFCS) reliability and maintenance study was one of five tasks of contract NAS1-14742 addressing selected advanced aerodynamic and active control concept development. The study provides a reliability and maintenance data base for contemporary flight controls against which future applications of active controls can be assessed.

The study objectives were to define and describe the significant operational characteristics of the PFCS. As specified in the statement of work, the description included primary control systems (elevators, rudder, ailerons), some secondary control systems (stabilizer trim, spoilers, and speed brakes), and hydraulic and electrical power supply systems. Autopilot actuators, which are integral with the hydraulic power control units, were not treated as separate components.

Two operational characteristics of the 747 PFCS were analyzed: control function reliability, and maintenance cost. The approach to the analysis of control function reliability was to determine component failure rates from airline data and then analyze these data using the CARSRA (computer-aided redundant system reliability analysis) computer program. The program was developed in the ARCS (airborne advanced reconfigurable computer system) study, contract NAS1-13654 (ref. 1), to evaluate the reliability of fault-tolerant computer systems applied to advanced flight controls. CARSRA was limited in its application to the PFCS analysis, but satisfactory results were obtained. The results were verified by another contractor program, CRAM (computerized reliability analysis method), as described in section 4.2.4.

The results show that for each primary control system (elevator, rudder, and aileron plus spoiler) the loss of function is less than 1×10^{-9} during a typical 4-hr 747 flight. This reflects the great failure tolerance of the 747 flight controls.

PFCS maintenance cost, the other operational characteristic considered, was analyzed using available airline data at the component level, including maintenance man-hours, material costs, and delay and cancellation rates. Both unscheduled and scheduled maintenance costs were generated as a function of flying time.

Mechanical flight control maintenance, which is mostly unscheduled, costs about \$3.94 per flight-hour. Such cost comprises 55% component overhaul, 5% line maintenance, and 40% delays and cancellations. To put such costs in perspective, the PFCS overhaul and line maintenance costs are similar to costs for the automatic flight control system (AFCS) determined during the ARCS study. The PFCS delay and cancellation costs, however, are more than 10 times those for the AFCS because of the dispatch criticality of primary controls. As found in the ARCS study, maintenance costs at the component level vary widely between airlines because of differing airline maintenance philosophies and operating methods.

Mechanical controls also are maintained on a scheduled basis through repeated inspections and checks. The cost for scheduled maintenance is established at \$0.19 per flight-hour. Scheduled maintenance probably will not be needed for active control system electronics.

Scheduled and unscheduled maintenance costs, plus reliability results and component data gathered from airline fleet experience, meet the objectives of providing the operational characteristics of the 747 PFCS.

2.0 INTRODUCTION

The model 747 primary flight control systems reliability and maintenance study was a 1-year effort sponsored by the Aircraft Energy Efficiency (ACEE) project office at NASA Langley Research Center. The study was one of several tasks performed in the Energy Efficient Transport (EET) element of the ACEE program.

2.1 STUDY OBJECTIVE

The purpose of this study was to define and describe the significant operational characteristics of the model 747 primary flight control system as they relate to system reliability and maintenance cost. The study provided data sufficient to establish these characteristics for a baseline contemporary flight control system against which future applications of active controls technology (ACT) can be assessed.

The model 747 was selected because it represents a current-technology airplane using mechanical devices assisted by powered actuators for primary control in flight. Also, useful 747 operational data were available from a previous contract study (airborne advanced reconfigurable computer system—ARCS), contract NAS1-13654 (ref. 1). This previous work involved maintenance cost and reliability assessment of the 747 automatic flight control system. A logical extension of this work was to evaluate reliability and maintenance cost for flight control electronics and to show the relationship between these two parameters and operating philosophies for different airlines.

The data base provided by the previous work on electronics and by this study can be applied in the reliability assessment of a derivative 747 using ACT concepts. Such concepts are being developed under contract NAS1-14741, also funded through the ACEE project office.

2.2 PRIMARY FLIGHT CONTROL SYSTEM DEFINITION

This study covered the mechanical portion of the flight control systems and the associated power sources. Actuation systems for both primary and secondary control surfaces plus the autopilot and yaw damper actuators were included in the study. Because the actuators are integral with the hydraulic power control units in the 747, they were not considered as separate components in the study analysis. Low-speed aerodynamic devices such as the leading edge wing flaps and trailing edge wing flaps were not included.

Some features of the PFCS include:

- o Ailerons, elevators, and rudders as primary control surfaces, with spoilers and stabilizer trim as secondary control surfaces.
- o Positioning of control surfaces using power from four independent hydraulic systems.

- o Transmission of manual commands via dual quadrants and dual cable loops.
- o Actuation by dual tandem pistons within structurally separate cylinders, pressurized by two hydraulic systems.
- o Dual linkage load paths to actuators.

Manual reversion has been eliminated because of the high number of power sources, command paths, power actuators, and control surfaces. Such capabilities give the flight control system great failure tolerance.

2.3 RELIABILITY ANALYSIS APPROACH

Reliability analysis of systems with high levels of redundancy has dictated the development of computer programs to handle the many failure combinations. One such program, CARSRA, was developed by Boeing under NASA sponsorship (ref. 1) to assess the reliability of future fault-tolerant computer systems. CARSRA was first tested during this study for its ability to model mechanical systems similar to those used in the 747 PFCS. The reliability results will be used as a baseline for assessing future designs, so the use of the same analysis technique will be helpful. Results from the CARSRA program were verified using an in-house program developed for general applications.

Because the 747 PFCS has inherent functional redundancy (e.g., stabilizer trim can be used for pitch control in certain elevator failure modes), the study concentrated on independent reliability evaluation for each control function. Failure data were gathered from airline component removal histories. Some of the mechanical components within the PFCS have low failure rates compared to those of electronic components. In such components, it was necessary to refer to a large data collection base compiled from model 747 reports provided by airlines.

2.4 MAINTENANCE COST APPROACH

The cost of maintaining aircraft systems is an important part of assessing new technology designs. Any gain made in reducing fuel costs by incorporating ACT may be affected by a change in maintenance cost. To determine such changes, the maintenance cost of the present hardware must be known—especially equipment that is expected to be replaced by new-technology hardware. Any change in an airline's maintenance practice for particular types of equipment also will affect the cost.

The cost categories for the 747 primary flight control systems include: scheduled line maintenance; unscheduled line maintenance; component overhaul shop maintenance, which is almost entirely unscheduled; and delays and cancellations. Scheduled maintenance consists of inspecting and checking such items as cables, pulleys, and mechanisms. It is anticipated that scheduled maintenance and its associated cost will be greatly reduced for airplanes having electrical devices for controls because maintenance on electrical equipment is usually accomplished on an unscheduled basis.

Some airlines closely monitor costs on unscheduled maintenance activity at the component level. Cost figures for this study were obtained or generated from such airline records. Data on costs for scheduled maintenance at the same detailed level, however, were not available because this type of maintenance is planned and is usually allocated a fixed budget. Actual costs for itemized tasks are difficult to obtain, so the scheduled maintenance costs were estimated for the PFCS from detailed planning requirements.

2.5 REPORT STRUCTURE

Study results are reported in three main sections. Section 4.1 describes each of the PFCS control functions and identifies the elements in the reliability analysis. Section 4.2 brings together the system modeling, functional failure rates for the modules, and definitions for failure; it also presents the results of the analysis using CARSRA. Maintenance costs at the component level are assessed in section 4.3. The study results are summarized in section 5.0. Detailed component data used in the reliability and cost analyses are included as appendixes to the report.

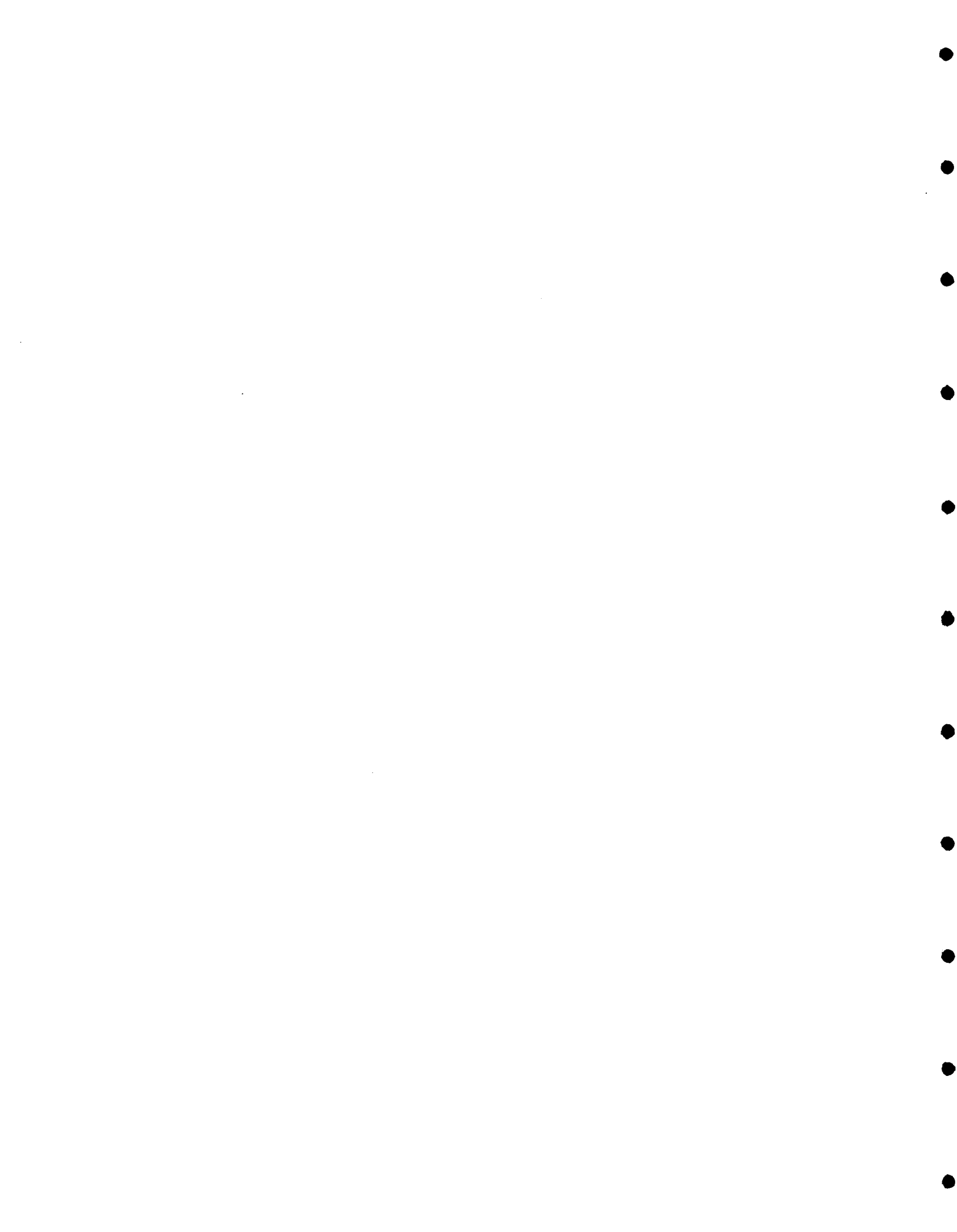

3.0 SYMBOLS AND ABBREVIATIONS

ACEE	aircraft energy efficiency
ACT	active control technology
AFCS	automatic flight control system
APU	auxiliary power unit
ARCS	airborne advanced reconfigurable computer system
CARSRA	computer-aided redundant system reliability analysis
CCA	central control actuator
CRAM	computerized reliability analysis method
CSD	constant-speed drive
EET	energy efficient transport
FAA	Federal Aviation Administration
F/C	flight control
GEN	generator
HYD	hydraulic
I/B	inboard
LH	left hand
LRU	line-replaceable unit
O/B	outboard
PCU	power control unit
PFCS	primary flight control system
POS	position
PRGMR	programmer
q	dynamic air pressure
RH	right hand

S/O	shutoff
SW	switch
SYS	system
λ	failures per million hours

4.0 STUDY RESULTS

The model 747 primary flight control system (PFCS) description, reliability assessment, and maintenance cost assessment are included in this section.

4.1 DESCRIPTION OF MODEL 747 SYSTEMS

Ailerons, rudders, and elevators provide primary control of the model 747 airplane flight attitude. The control surfaces are positioned by hydraulic power packages served by four independent hydraulic systems. The surfaces are controlled by conventional aileron control wheels, elevator control columns, and rudder pedals. Secondary controls include an adjustable horizontal stabilizer and spoilers. The horizontal stabilizer is positioned by hydraulic motors controlled primarily by switches in the aileron control wheel. The spoilers are hydraulically powered from different hydraulic systems and are positioned by an output from the aileron control system. When used as speed brakes, the spoilers are controlled by a speed brake control lever. The layout of these control surfaces on the 747 is shown in figure 1.

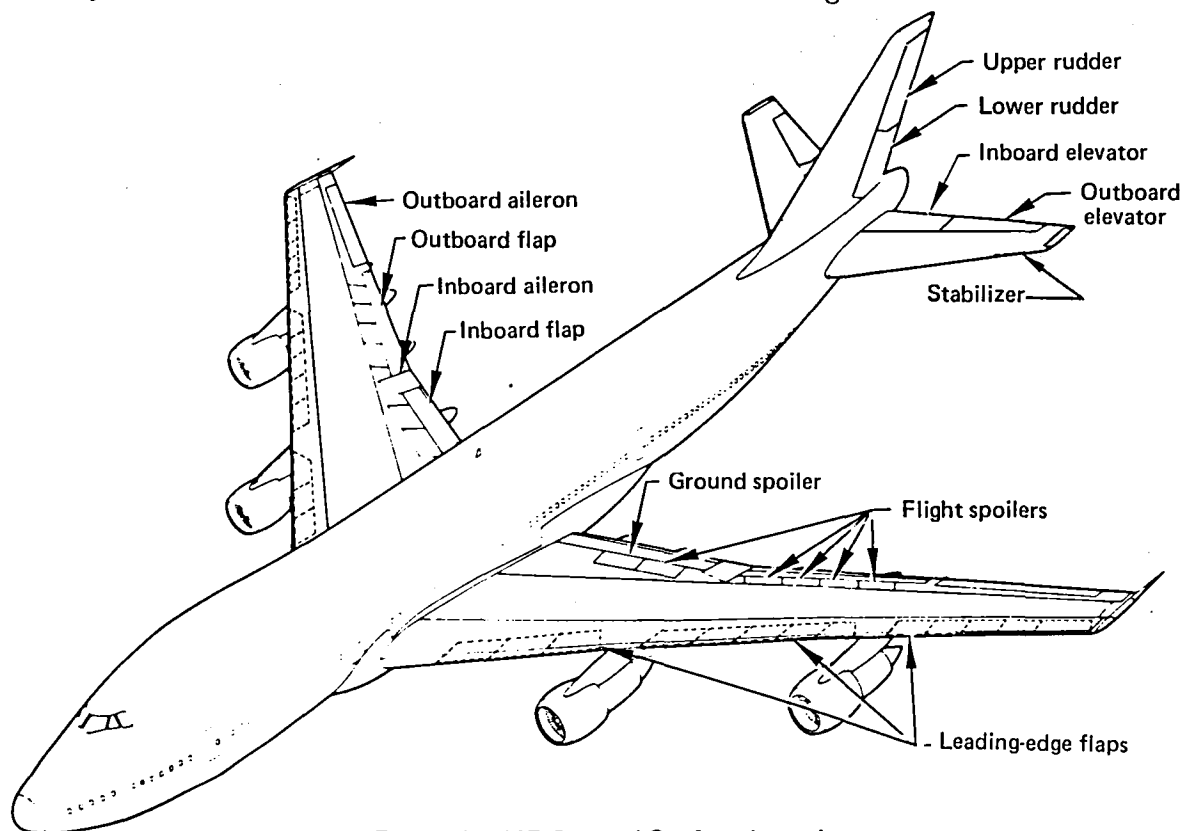

Figure 1. 747 Control Surface Location

Lateral trim is accomplished by shifting the neutral position of the aileron control system. The repositioning is controlled by a switch on the pilot control stand. Rudder trim is provided by shifting the neutral position of the rudder control system by a rudder trim control knob located on the pilot control stand. Repositioning of the horizontal stabilizer provides pitch trim of the airplane.

Control surfaces can also be actuated through the autopilot and yaw damper systems. The autopilot systems control the electrohydraulic transfer valves on the autopilot modules. The modules, which are part of the power control packages, are included as part of the respective control system description.

Because each control system depends on its hydraulic and electrical power sources, the power sources are described in separate sections. Functional and reliability diagrams serve as a logical introduction to the analysis section for each system description in the report.

The functional block diagrams for each system define the relationships of the hardware elements to the power sources they control or that control them. The diagrams further identify the elements necessary for the system to operate. Each function within the system is defined by a block in the diagram; a block may represent a complex piece of equipment or a simple single unit. The reliability block diagrams show only component parts essential to the proper functioning of the system. Figure 5 is an example of a functional block diagram and figure 6 is an example of a reliability block diagram.

The following discussion is divided into seven sections dealing with:

- o Elevator control (4.1.1)
- o Stabilizer trim (4.1.2)
- o Lateral control (4.1.3)
- o Rudder control (4.1.4)
- o Speed brakes (4.1.5)
- o Hydraulic power supply (4.1.6)
- o Electrical power supply (4.1.7)

4.1.1 Elevator Control

The elevator control system provides primary control of the airplane about its pitch axis. The elevator is divided into four segments (fig. 2), each of which is positioned by hydraulically powered control units.

The system consists of pilot and copilot control columns, a forward quadrant and crank, a common aft quadrant, cables, linkage, and four power control units. No provision has been made for manual reversion. Artificial feel forces for the system are obtained through a dual-feel computer control unit.

Elevator positioning is achieved by manual or autopilot actuation. Manual control is obtained from either the pilot or the copilot control column, which are linked together mechanically. Duality is maintained with a separate cable system from each control column to the dual-linkage aft quadrant. Manual command signals from the aft quadrant to the inboard power control units (PCU) are transmitted through dual linkage. The outboard elevators are slaved to the inboard elevator outputs by a single cable system. Autopilot input signals can be transmitted to either or both of the inboard position servos mounted within the PCU, and the pilot can select the operational channel. Autopilot operation of either position servo causes the entire manual control system to move, including both control columns. Pitch control can also be achieved by changing the incidence of the horizontal stabilizer, which is described in section 4.1.2.

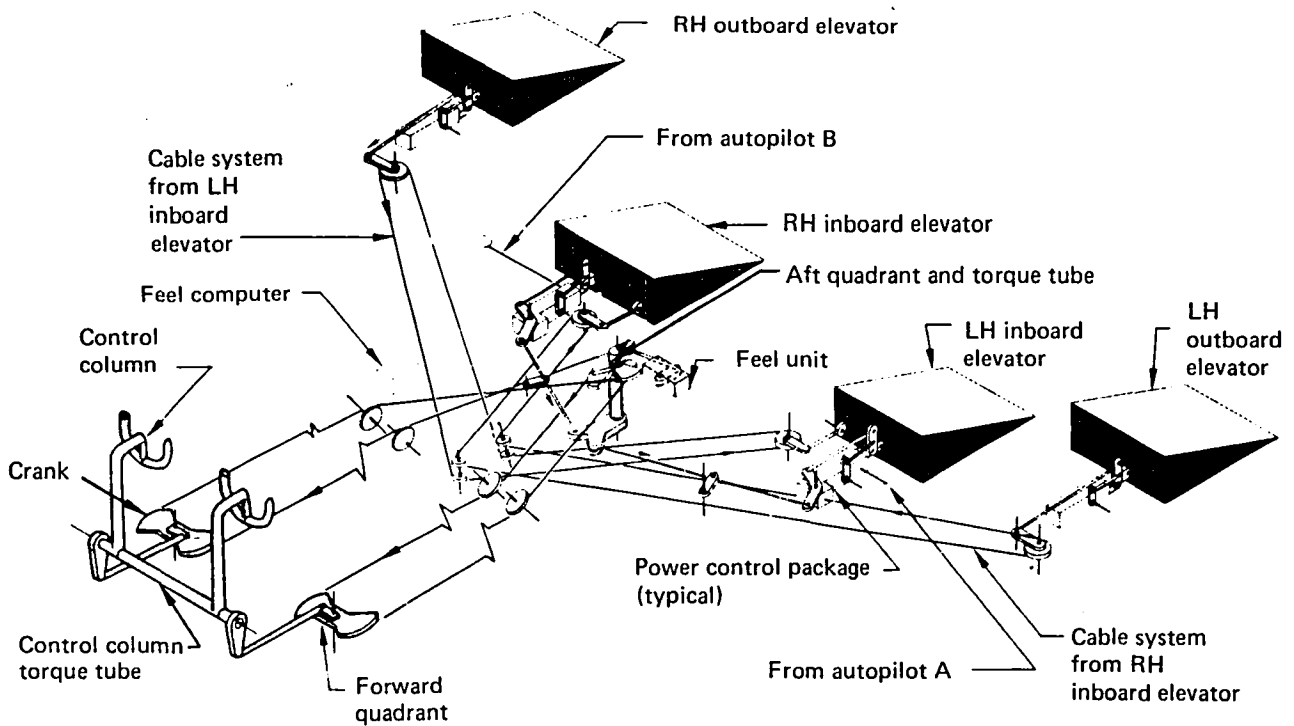

Figure 2. Elevator Control System

The following paragraphs describe in detail each element of the elevator system, which is then summarized in a functional block diagram. Also, elements essential to system operation are presented in the reliability block diagram. These two diagrams are shown on pages 14 and 15.

4.1.1.1 Control Columns and Forward Quadrant

The control columns are rigidly mounted on a torque tube. Crank assemblies on each end of the torque tube transmit motion aft by pushrods to the forward quadrant and crank. Stops on the left torque tube crank and its bearing housing limit movement of the control column. Separate pairs of cables connect the crank and forward quadrant to the common aft quadrant. A tension regulator in the forward quadrant mechanically compensates for the effects of temperature variation and structural deflections on the elevator system. The range of regulator tension compensation is limited by positive stops.

4.1.1.2 Aft Quadrant and Torque Tube

A common aft quadrant receives the cable-transmitted input from the forward quadrant and crank. The aft quadrant is mounted on a torque tube located on the stabilizer hinge bulkhead. A dual load path is incorporated into the torque tube to prevent a single torque tube failure from incapacitating the elevator control system. A lever arm and linkage on the torque tube transmit centering forces and artificial feel from the feel unit to the cable system. Another lever arm conveys input through linkages to the input controls on each inboard power control package.

4.1.1.3 Elevator Feel System

The feel computer is the controlling element in a hydraulically powered subsystem comprising the computer, a feel actuator, and a feel unit (see fig. 3). The computer modulates hydraulic pressure inputs to the feel actuator in response to changes in dynamic air pressure and horizontal stabilizer position. Airplane hydraulic systems 2 and 3 provide the hydraulic pressure inputs from which feel pressure is derived.

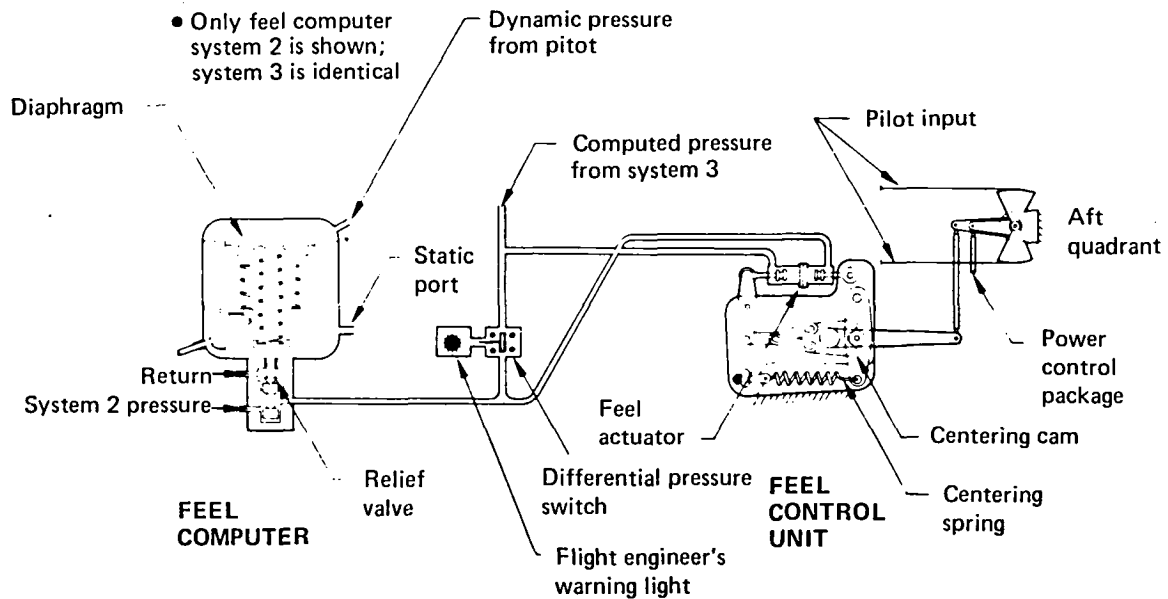

Figure 3. Elevator Feel System

The computer contains two identical groups of components, each providing a separate feel pressure input to the feel actuator. A pressure-differential sensing actuator in the computer senses the pressure output of both groups of components. The actuator closes one of two switches if the output pressure from one group falls to about 75% of the output from the other group. Operation of either switch illuminates an ELEV FEEL indicator light on the center instrument panel. A pressure transducer in each component group senses the difference between feel pressure and system return pressure, then transmits a voltage, proportional to feel pressure, to the autopilot pitch control channel.

The feel actuator, which is mounted on the elevator feel unit, receives hydraulic pressure inputs from the feel computer. The actuator contains two rams moving in opposite directions within a free-floating cylinder. One ram is connected to the feel unit body, which is attached to the airplane structure, and the other to the feel linkage. The force exerted by the actuator is proportional to the parallel outputs of the feel computer; therefore, failure of one output does not affect elevator feel.

The feel unit transmits the force from the feel actuator to the elevator controls. Feel pressure acts on the feel actuator rams to apply force through a Y-linkage attached to a cam mounted on a pivot shaft. A lever mounted on the same shaft connects the feel unit to the elevator aft quadrant. When moving the control column in either direction, the operator must overcome the feel force transmitted through the linkage to rotate

the cam. As the cam rotates, a roller in contact with the cam surface moves out of detent, displacing a lever arm held in place by two centering springs. When the pilot releases the control column, the roller exerts pressure to center the cam, acting with the feel pressure to return the control column to neutral. Loss of feel force is not considered to cause loss of the elevator control function.

4.1.1.4 Inboard Elevator Controls

Motion from the aft quadrant, through the torque tube, is transmitted to each inboard elevator power control package by a mechanical linkage. The linkage has a dual load path so that a single failure will not affect elevator operation. The inboard elevator power control packages are dual-tandem hydraulic power units that actuate the inboard elevators. Each package (fig. 4) drives its associated inboard elevator independently. The left package is powered by hydraulic systems 3 and 4, and the right package is powered by hydraulic systems 1 and 2. Figures 5 and 6 illustrate hydraulic system interconnections. The two hydraulic systems are isolated within the package so that loss of one system cannot cause loss of a second system; in the reliability analysis (sec. 4.2), the package is represented as two modules. Pressurization of the overtravel mechanism provides a hydraulically supported pivot for the control linkage, thus arming the linkage. With the linkage armed, control inputs are applied to the main control servo valve. Feedback linkage from the actuator returns the control valve to neutral when the correct amount of elevator movement has been achieved. Return fluid from the actuator chambers passes via the main control valve to a compensator, which it charges to capacity, if required. Pressure buildup then opens a check valve in the compensator piston, allowing the fluid to exit through the return port. The compensator retains a reserve of pressurized return fluid to ensure proper operation of check valves within the package.

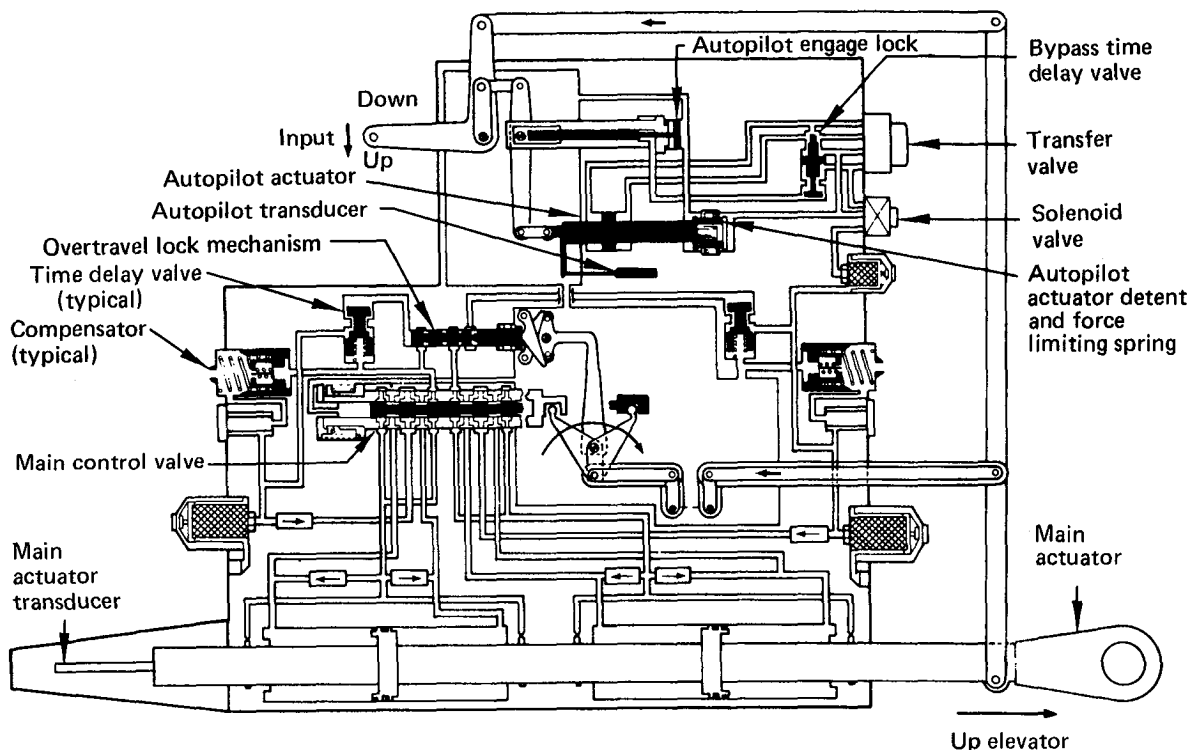

Figure 4. Inboard Elevator Power Control Unit

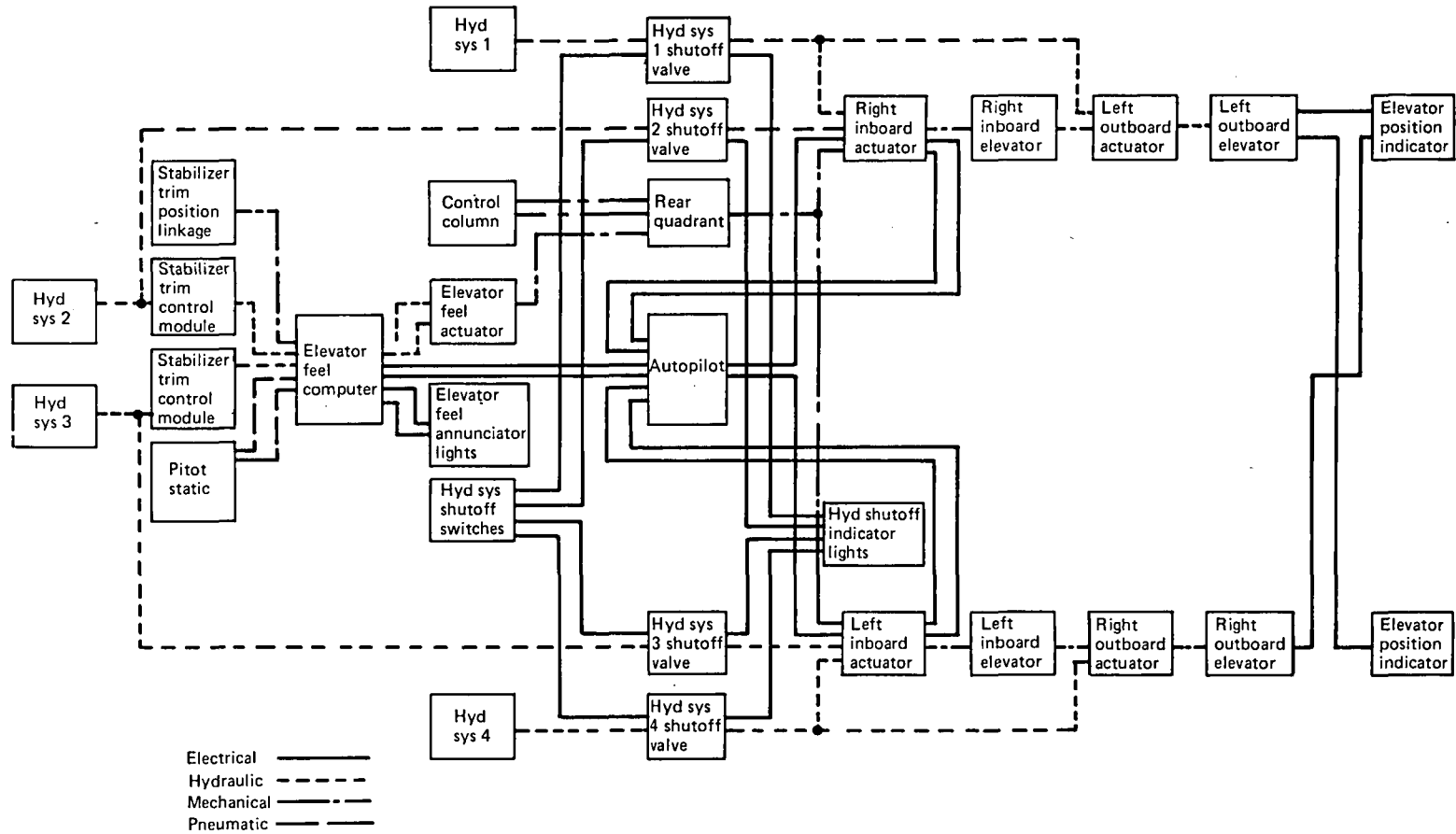

Figure 5. Elevator Control Functional Block Diagram

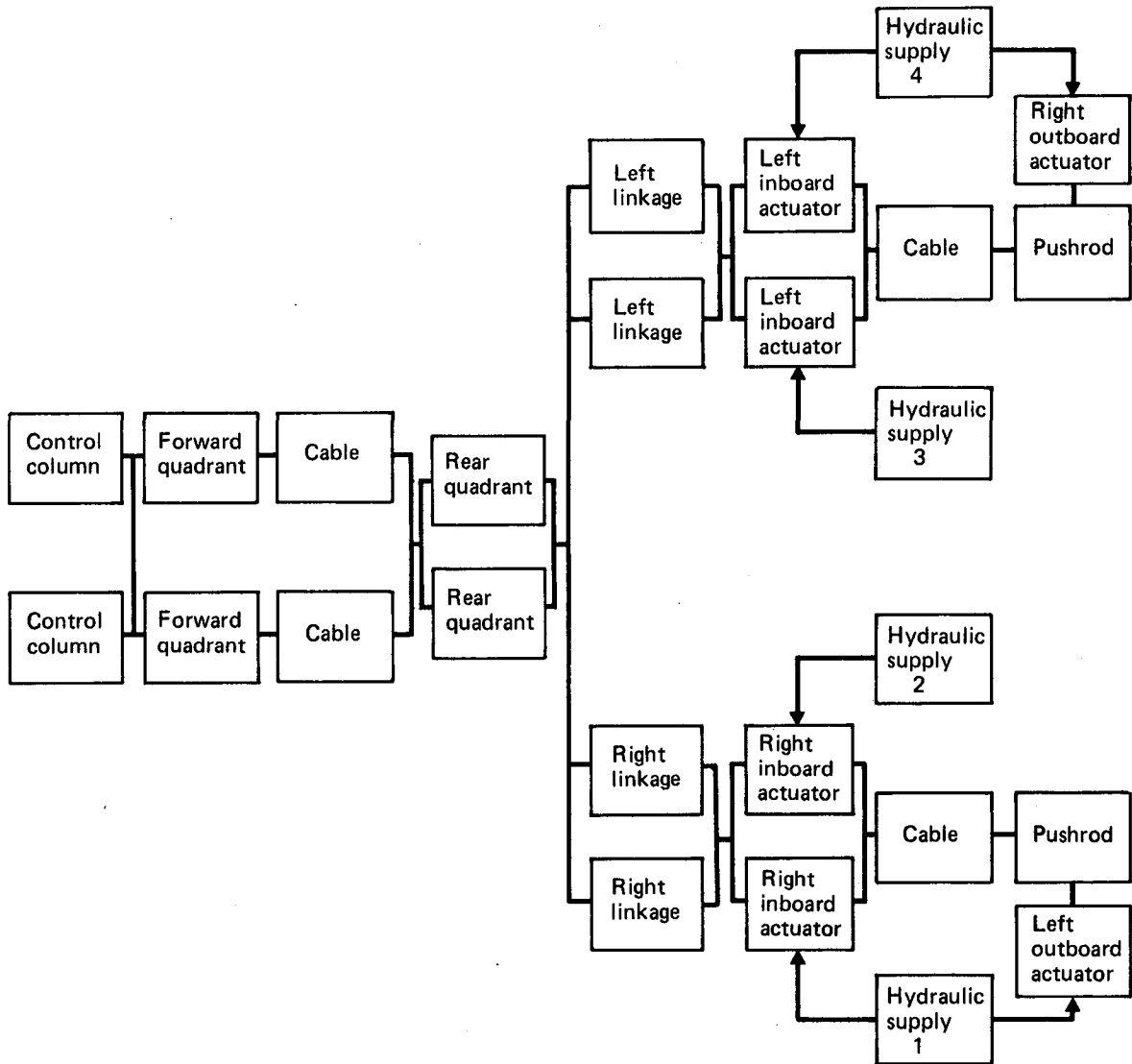

Figure 6. Elevator Control Reliability Block Diagram

4.1.1.5 Autopilot Elevator Control

In the autoflight mode, electrical signals generated by the autopilot pitch channels operate the inboard-elevator power-package control-valve linkages. An electrically operated transfer valve in the autopilot module controls a hydraulically driven positioning piston connected directly to the linkage.

For autopilot operation, fluid from each pressure port passes to the autopilot module, then to a solenoid valve. When the autopilot is engaged, the solenoid directs pressure to the autopilot engage lock. When the bypass valve closes, pressure applied to the autopilot engage lock arms the autopilot linkage by providing a hydraulically supported pivot. Autopilot commands operate a transfer valve to direct fluid from the solenoid valve to the appropriate chamber of the autopilot actuator. The autopilot actuator consists of an actuator piston connected to the autopilot input summing lever through a force-limiting and valve-regulating spring assembly, a closed-center, three-way

regulating valve, and an actuator-positioning detent spring. The force-limiting and valve-regulating spring assembly provides a detent for the regulating valve and limits the force authority of the autopilot actuator. This force limitation ensures that manual control column inputs can be applied to override autopilot inputs, if necessary. The autopilot actuator operates the linkage to position the main control valve, initiating main actuator response.

A linear transducer connected to the autopilot actuator signals the position of the actuator to the autopilot pitch control channel. A linear transducer connected to the dual-tandem main actuator provides a feedback signal to the autopilot pitch control channel to close the servo loop.

4.1.1.6 Outboard Elevator Control

The mechanical control to each outboard-elevator power-control package is transmitted mechanically through a slave system from the opposite inboard elevator. A pushrod connected to the front spar of the inboard elevator operates an inboard quadrant, which is connected by cables to the opposite outboard quadrant. A pushrod from the outboard quadrant connects to the input linkage of the outboard elevator power control package. No hydraulic or mechanical connection exists between outboard and inboard packages on the same side. The left outboard package is powered by hydraulic system 1; the right outboard package is powered by hydraulic system 4.

4.1.1.7 Surface Position Indication

A control surface position transmitter, connected to each outboard elevator, transmits electrical signals to a control surface position indicator in the control cabin. The indicator is a composite instrument that shows the positions of the outboard elevators, ailerons, spoilers, and rudders. Functional and reliability block diagrams are shown in Figures 5 and 6 on pages 14 and 15.

4.1.2 Stabilizer Trim

The stabilizer control system (fig. 7) uses a linear, ball-screw actuator, driven by two hydraulic motors, to pivot the stabilizer about its rear attachments to the empennage structure. A gimbal mounting attaches the lower end of the mechanism to the empennage structure. A ball nut, driven by the jackscrew, connects to the stabilizer through the upper gimbal attachment. Two independent modular control packages direct hydraulic power to the trim drive mechanism.

The system provides four modes of stabilizer trim control: three electrical modes, and an emergency manual-mechanical mode. The electrical modes permit manual-electric actuation by either the pilot or copilot or automatic actuation by the autopilot systems. The open-loop control system is designed to prevent trim in opposition to the direction commanded or runaway trim. Functional and reliability block diagrams for the stabilizer trim are shown on pages 21 and 22 in the following detailed description.

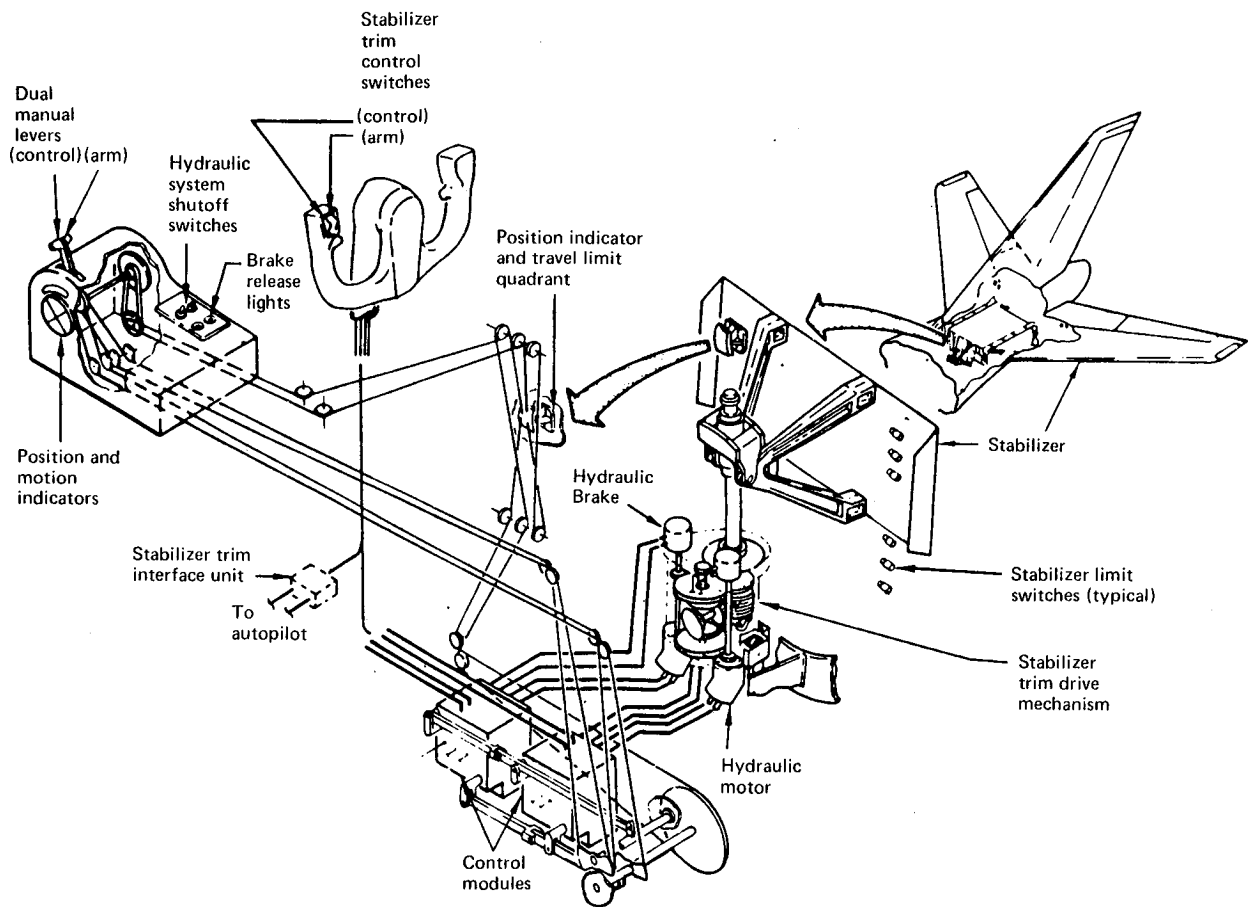

Figure 7. Stabilizer Trim System

4.1.2.1 Stabilizer Trim Control Switches

Duplicate control switches, located in the pilot and copilot control wheels, actuate the stabilizer trim systems in the manual-electric control mode (see fig. 7). The two segments in each switch are mechanically and electrically isolated from each other. Each segment operates a pair of solenoids on each control module. One segment controls a pair of arming solenoids and the other controls a pair of directional control solenoids. Because both an arming solenoid and its associated directional control solenoid must be energized to trim the stabilizer, both segments must be held in the same direction to initiate movement. This ensures that a malfunction in a single segment of the circuit cannot cause a runaway stabilizer.

4.1.2.2 Autopilot Stabilizer Control

The autopilot control mode is connected through two separate dual-channel systems (A or B), which operate the arming and control valves of the hydraulic modules. During cruise, only one channel is used, but both channels may be switched on during landing. In this mode, the first channel is operative and the second is armed and in a standby state. If the first channel malfunctions, control is automatically transferred to the standby (second) channel.

If there is disagreement between the arming or control circuits and the secondary hydraulic brake pressure switch, the autopilot warning light will come on 3 sec after the disagreement occurs. The warning light also comes on if a 12-sec out-of-trim condition occurs.

The autopilot mode has no authority over any other mode. When the autopilot is in operation and a signal is generated by the thumb switches, the autopilot channel disengages.

4.1.2.3 Stabilizer Trim Limit Switches

In the electrical control modes, limit switches prevent the stabilizer from moving beyond the positions required by the normal flight envelope for the prevailing operating condition. Travel limit and warning horn switches are mounted outboard on the aft face of the actuator bulkhead. Cams attached to the stabilizer front spar actuate the switches. One pair of switches limits travel in the manual-electric control mode and two pairs limit travel in the autopilot control modes (one pair for each autopilot channel).

The trim system contains an elevator-operated trim cutoff that is operated by switches in the elevator control system. Two pairs of micro switches on the structure beneath the control cabin are actuated by the elevator forward quadrant. Two switches are operated by the control column in the elevator up direction, and two by movement in the elevator down direction. The switches operate relays in the stabilizer trim interface. The relays interrupt electrical commands to the stabilizer if the control column is moved more than 5.5 deg from neutral in a direction opposed to the trim. The signal path commanding trim in the opposite direction is left intact.

4.1.2.4 Stabilizer Trim Levers

Two levers on the pilot side of the control stand actuate the system in the manual-mechanical control mode. The levers perform essentially the same functions as the stabilizer trim switches, but they operate through separate mechanical systems. The right lever operates an arming servo valve in each modular control package, and the left lever operates a control servo valve in each package.

Both levers must be moved in the same direction to trim the stabilizer. This ensures that a runaway trim cannot occur if a malfunction jams one lever in either direction. The dual control levers exercise complete authority over all modes. Thus, complete control is achieved by the hydraulic module servo valves, which hydraulically interrupt any other trim signal when the levers are operated.

In the mechanical control mode, a cable system shuts off power to the hydraulic motors before the mechanical stops are reached. Mechanical control permits travel beyond the electrical limits to satisfy all performance requirements. Mechanical stops on the jackscrew limit absolute travel, but the trim system does not normally drive the stabilizer to the stops.

4.1.2.5 Hydraulic Power

Airplane hydraulic systems 2 and 3 supply power for the stabilizer trim system. Each system supplies power to an independently functioning group of components. Each group of components consists of a modular control package, hydraulic motor, and hydraulic brake. Hydraulic system 2 supplies the left component group, while hydraulic system 3 supplies the right component group.

4.1.2.6 Hydraulic Modules

Two identical modules consist of an arming valve, control valve, two manually controlled servo valves, four dual-wound, solenoid-operated valves, a rate control valve, motor-operated shutoff valve, and a secondary brake pressure switch (fig. 8). A motor shutoff valve upstream of the rate control valve in the pressure line is operated by a switch located on the aisle stand in the control cabin. The rate control valve, which is a spool valve positioned by a "Q" bellows-linkage assembly, controls the output of the hydraulic motor and the stabilizer trim rate.

When the trim has been selected in either direction, hydraulic fluid enters each module through integral check valves to the rate control valve, which regulates the fluid flow rate in proportion to aircraft speed. The flow, which is directed by the arming and control up or down solenoid, continues through the arming and control service ducts. The solenoids direct the flow to the arming valve and the control valve.

When energized, each solenoid releases pressure from a balance cylinder at one end of its corresponding valve. Pressure exerted by the opposite solenoid on the other end of the valve drives the valve to the end of its travel in the selected direction.

With both the up and down solenoids deenergized, the valve is pressure-balanced and spring-loaded to the center neutral position. With both the arming and control valves positioned to command trim in the same direction, fluid is directed through outlet ports to the trim drive mechanism. Fluid cannot flow if only one valve is positioned directionally.

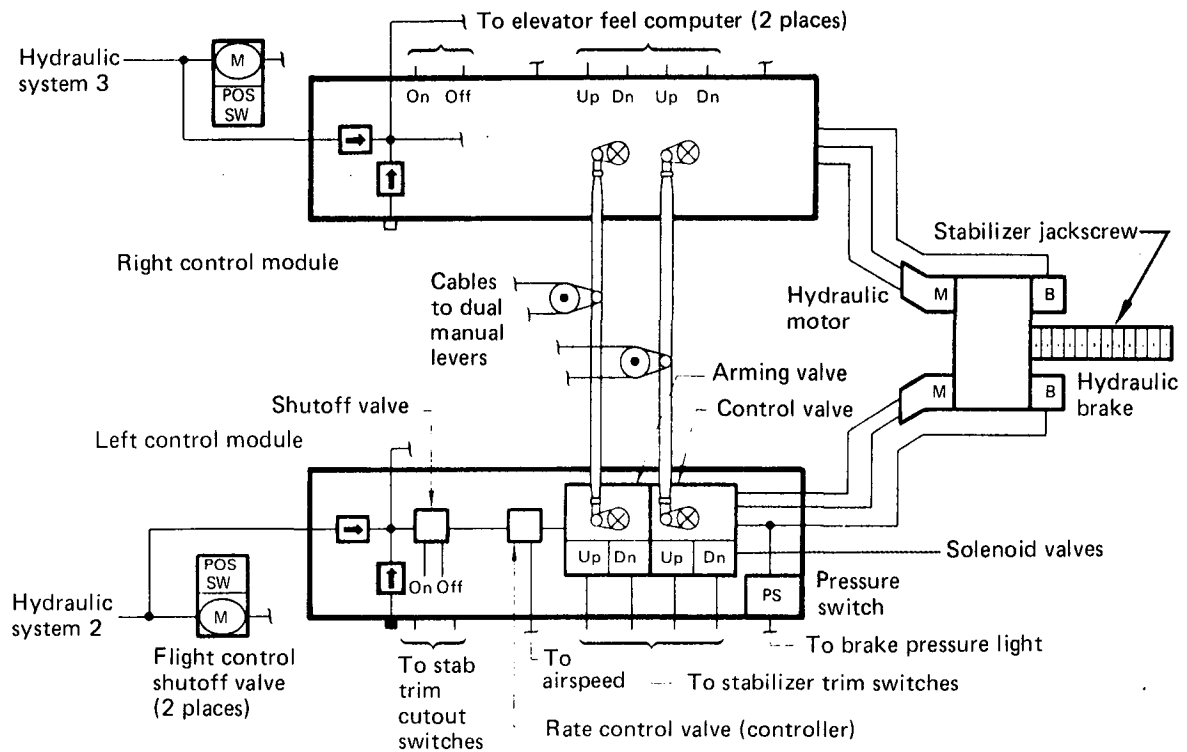

Figure 8. Stabilizer Trim Control Modules

4.1.2.7 Stabilizer Trim Drive Mechanism

Two hydraulic motors convert hydraulic pressure to rotary motion to drive a jackscrew. The drive mechanism (fig. 9) also includes two hydraulic secondary brakes, a primary brake, differential, bull gear, and ball nut.

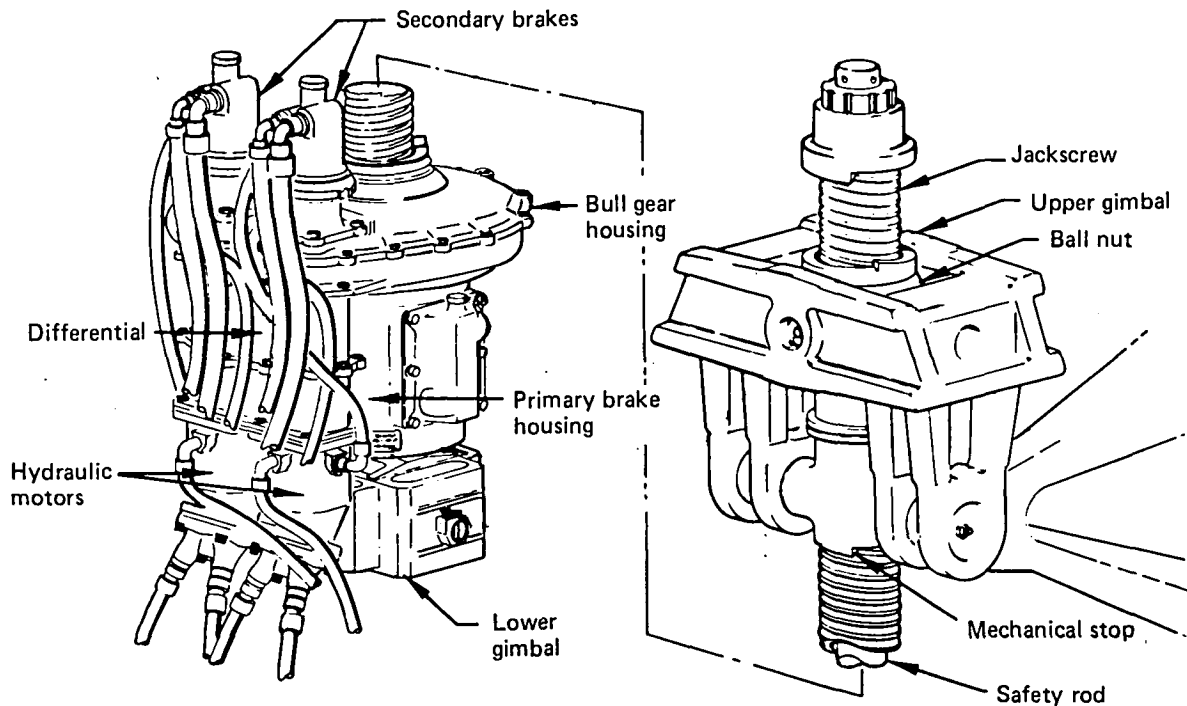

Figure 9. Stabilizer Trim Drive Mechanism

Each combination of motor and brake, activated by its associated modular control package, can control stabilizer movement independently through the differential. In normal operation, however, the two combinations act together. Each motor is a nine-cylinder, piston-type, reversible unit. The differential, a dual load path from input to output, is bolted to the bull gear housing.

The bull gear housing contains a spur gear splined to the jackscrew. To prevent the stabilizer front attachment from failing if the jackscrew fails, a safety rod is inserted lengthwise through the jackscrew. The safety rod is held in place by a safety nut at the top of the rod and a safety sleeve and shaft at the bottom.

The jackscrew drives a ball nut consisting of a primary and a secondary nut splined together and joined by a bolted, mating flange. Ball bearings circulate within the primary nut and through two external ball return tubes to transmit the drive from the jackscrew to the upper, primary nut.

The ball nut achieves its loading duality through two ball circuits. Only one of the two ball circuits is loaded. If this circuit fails, the second ball circuit carries the load. The lower, secondary nut carries loads only if a primary nut or gimbal yoke fails.

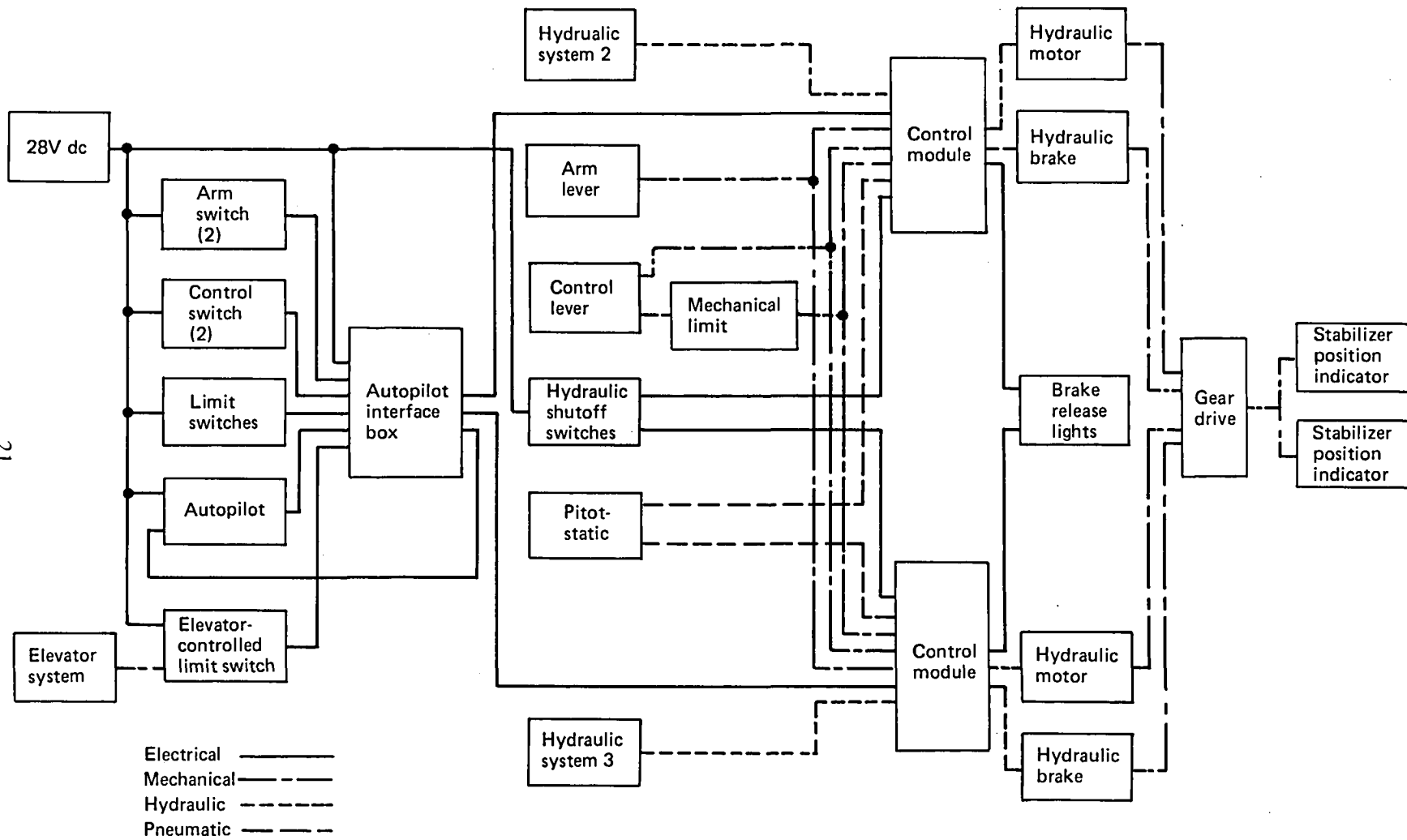

Figure 10. Stabilizer Trim Functional Block Diagram

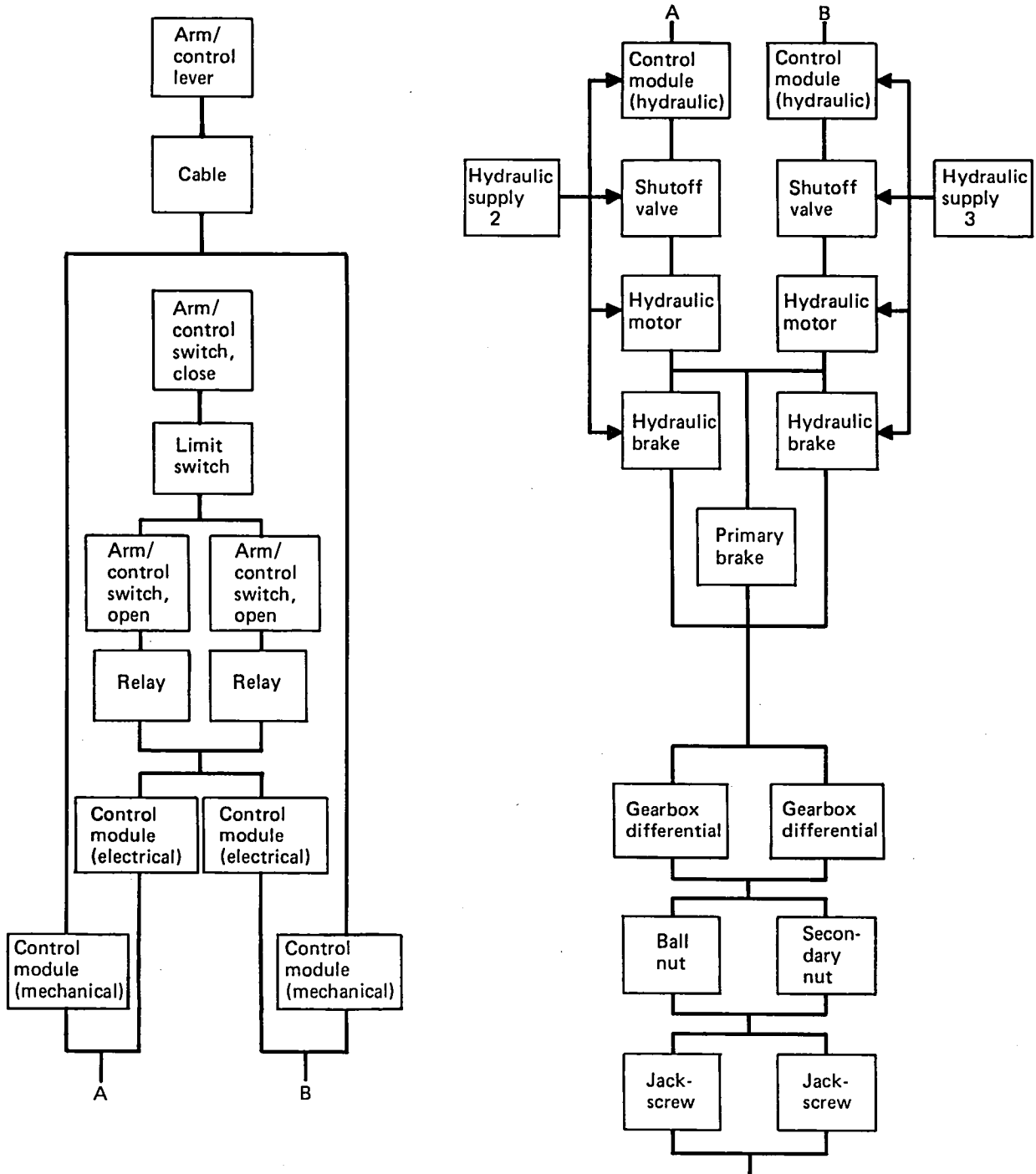

Figure 11. Stabilizer Trim Reliability Block Diagram

The primary and secondary brakes prevent the stabilizer from creeping when it is stationary. The primary brake is applied by the thrust exerted on the jackscrew by stabilizer air loads. Downward thrust compresses the lower brake disk of the primary brake between the flange and the lower ratchet. Because the jackscrew is right-hand

threaded, downward thrust exerts pressure to turn it clockwise (viewed from the drive end). But two diametrically opposed pawls prevent the lower ratchet from turning clockwise, thus constraining the screw. Upward thrust exerted on the screw compresses the upper disk and applies counterclockwise torque, which is similarly resisted by the upper ratchet. The actuator drive that trims the stabilizer in a direction opposed to air-load thrust is unresisted, because the ratchet and compressed brake disk rotate freely with the flanged screw shaft. Drive in a direction with the thrust is opposed by the primary brake. The hydraulic motors, assisted by the thrust exerted by the air load, overcome brake friction to trim the stabilizer in this direction. The hydraulic brakes and control valves provide secondary braking by hydraulically locking each motor when no trim signal exists.

4.1.2.8 Stabilizer Position Indication

Two BRAKE release lights and two STAB TRIM lights indicate the operating status of the system. The BRAKE release lights are mounted on the control stand to the right of the throttles in the control cabin. The remaining lights, the autoflight system annunciator lights, are located on the forward center instrument panel.

A stabilizer position indicator dial is located on each side of the control cabin aisle stand. The dial is connected directly to the stabilizer by a cable system that transmits the stabilizer position to the dial needle. In addition to the dial indicator, the stabilizer operation is also indicated by rotating wheels with color bands and an audible generator indicator. Each dial has a green band that shows the safe range for the stabilizer trim position during takeoff.

Functional and reliability block diagrams are shown in Figures 10 and 11 on pages 21 and 22.

4.1.3 Lateral Control

Lateral control of the airplane is provided by two ailerons in each wing and by the spoilers (see fig. 12). The ailerons are hydraulically powered using all four airplane hydraulic supply systems.

The ailerons are controlled by conventional control wheels interconnected with drums and cables below the control columns. The control cables connect the drum at the pilot control column to a cable quadrant in the left wing-gear wheel well. The quadrant includes a trim mechanism and also provides artificial feel to the aileron control system. The trim and feel mechanism provides input to the hydraulically powered left and right central control actuators, which also receive input from the airplane autopilot system.

The mechanical input to the central control actuators moves internal control valves, which causes the actuators to provide a hydraulically powered output. The upper piston rod of each actuator is connected to a spoiler differential that controls the five flight spoilers in the respective wing. The lower piston rod of each actuator is connected to an aileron programmer that transmits the output by cable to the respective wing. The cables are attached to an aileron power-package control quadrant at each control surface. The outboard ailerons, which are used for low-speed operation only, are isolated from the aileron system by a lockout mechanism. The lockout mechanism prevents the outboard ailerons from operating when the outboard flaps are fully retracted. It is engaged by an electric actuator that receives power through a flap-actuated switch.

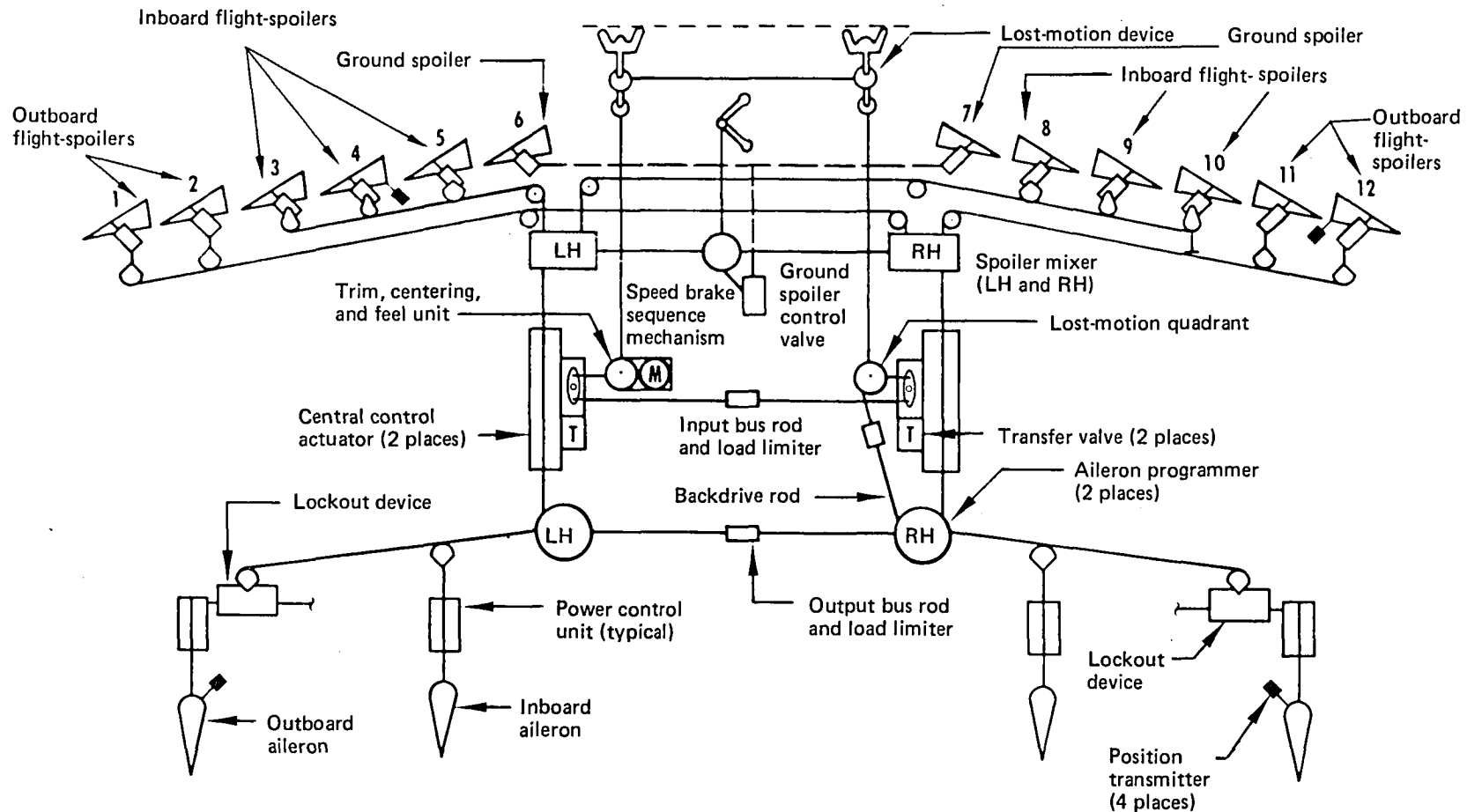

Figure 12. Lateral Control System

The spoiler control system supplements the ailerons at all speeds in providing lateral control of the airplane. Of a total of 12 spoilers, 10 are flight spoilers and 2 are ground spoilers. Only the flight spoilers are used with the spoiler control system. However, the flight spoilers are used with the ground spoilers in the speed brake control system, which is discussed fully in section 4.1.5. The two outer spoilers (numbers 1, 2, 11, and 12, fig. 12) are outboard flight spoilers. The next three spoilers on each side (3, 4, 5, 8, 9, and 10) are inboard flight spoilers. The two remaining spoilers (6 and 7) are the ground spoilers.

The control input to operate the flight spoilers comes from the central control actuators, through the spoiler control differential mechanisms, and then by cables to the control valves of the flight spoiler power control packages. Spoiler extension is limited by aerodynamic blowdown forces in proportion to airspeed.

The functional block diagram following the description details shows the spoilers and ailerons used for the lateral control function. The reliability block diagram shows which spoilers are paired together for the reliability analysis.

4.1.3.1 Aileron Control Load Limiter

The aileron control load limiter shown in figure 13 performs two functions. It provides an alternative system to move the ailerons if either body cable system should jam, and it incorporates a lost-motion feature to prevent undesired feedback of cable system motion into the aileron control wheels.

If the left body control cables become jammed, the pilot control wheel becomes inoperable. In this case, the copilot control wheel must be used to maintain lateral flight control. The lost-motion feature of the copilot control wheel is provided by the load limiter. This permits the control wheel bus drum to move with respect to the load limiter drum within certain mechanical stop limitations. Up to ± 4 deg of system lag is permitted without causing any input to the aileron control wheels.

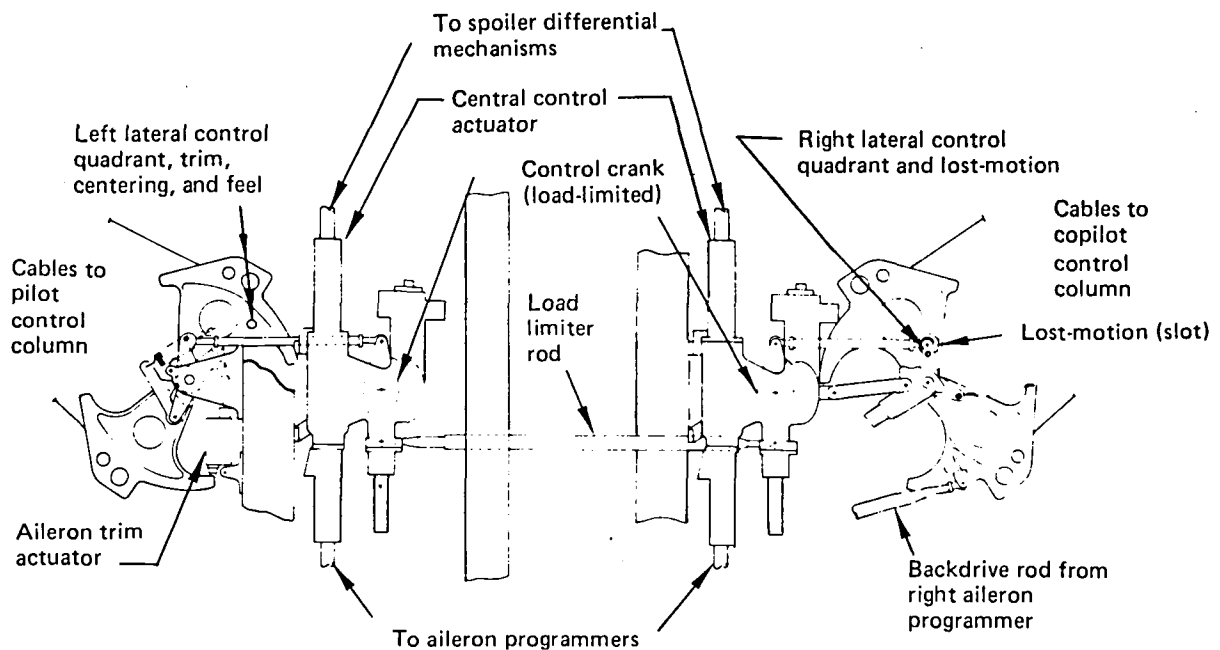

Figure 13. Central Control Inputs

4.1.3.2 Aileron Trim and Feel Mechanism

The aileron trim and feel mechanism (fig. 13) provides artificial feel at the aileron control wheels. It also centers and trims the lateral control system. The mechanism receives its input from the left body control cables and provides an output to operate the central control actuators.

Trim input to the mechanism is provided by a trim actuator. The actuator consists of an electric motor and jackscrew that provide linear motion of the output shaft. The actuator is controlled by switches on the pilot control stand; the actuator output shaft is connected to the mechanism support assembly. Output of the actuator establishes a new control system neutral position by repositioning the entire trim and feel mechanism, including the input quadrant. Such rotation provides an input to the central control actuators, which position the lateral flight control surfaces to give the desired trim correction. Rotation of the input quadrant in response to trim input also repositions the aileron control wheels away from the normal neutral position.

The trim actuator position is not affected by reverse forces resulting from normal control of the system. Loss of the feel and trim system will not cause loss of the lateral control function.

4.1.3.3 Central Control Actuators

The aileron programmers and spoiler differentials are operated by two mechanically connected central control actuators. The actuators receive lateral control input and provide a hydraulically powered output to operate the programmers and differentials. Hydraulic pressure is provided to the left actuator from systems 1 and 2. Hydraulic supply systems 3 and 4 provide power for the right actuator. The actuators also include provisions for input from the autopilot system.

Mechanical input to each actuator is transmitted through dual load path cranks to the primary and secondary summing levers (fig. 14). The primary summing lever is connected directly to the spool of the main control valve. The valve is a dual tandem valve with the valve sleeve connected to the secondary summing lever.

During normal operating conditions, the sleeve is rarely repositioned. Motion of the valve spool or sleeve directs hydraulic fluid from both supplying systems to a tandem actuator that provides the input to the spoiler differential and aileron programmer. The summing levers, which are connected to the actuator, provide the follow-up motion to close the control valve when the actuator reaches the desired position.

Autopilot components within the actuator include a solenoid valve, electrohydraulic servo valve, autopilot cylinder bypass valve, autopilot actuator, and two linear transducers. During manual operation using the aileron control wheels, hydraulic fluid in the autopilot actuator circulates, preventing a hydraulic lock and allowing the summing levers to move. Autopilot operation is accomplished by electrical signals applied to the transfer valve, which controls the flow of hydraulic fluid to the autopilot actuator. When the autopilot actuator is moved, the main electrohydraulic servo valve is positioned through the summing levers. From this point, functioning is identical, irrespective of the mode of operation (manual or autopilot). Movement of the tandem actuator, transmitted through the summing levers, provides the feedback signal to the main control valve. Autopilot feedback signals are provided by linear transducers positioned by the autopilot actuator and the tandem actuator.

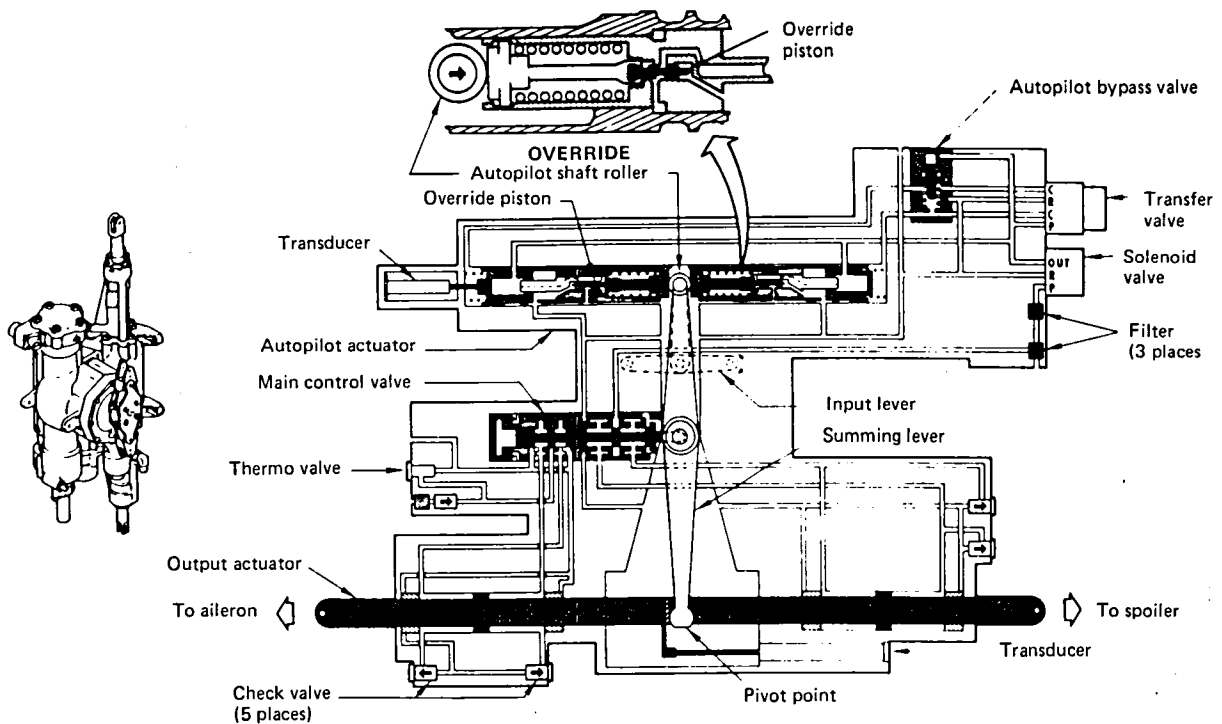

Figure 14. Central Control Actuator Schematic

Spring detents, force limiters, and lost-motion features permit system operation if a component fails. A spring detent is located on the input link to each central control actuator. In the event of jamming within an actuator, the link disengages in response to a small aileron control wheel movement, permitting full valve travel in the alternate actuator. In either control system, any jamming that may occur between an aileron control wheel and the control actuator is bypassed by the aileron control load limiter. The spring force is overcome in the limiter, permitting the left body cables to operate even though the right body cable system is jammed. In this condition, the system can be operated by the pilot control wheel. If the left body cable system jams, the system can be operated by the copilot control wheel through the right body cables. If the hydraulic system within one actuator fails completely, the related programmer will not move. The opposite central control actuator, however, will respond to a signal by moving its programmer and providing the input to override the force-limiting rod between the programmers. This permits the aileron to be operated on the same side of the airplane as the operable central control actuator.

4.1.3.4 Aileron Programmers

The aileron programmers control the motion of the ailerons relative to movement in the aileron control wheel. Two programmers are installed, one on each wing, with each programmer providing the output for its respective wing. The programmers are designed to produce a relatively large amount of aileron travel from an initial rotation of the control wheel away from neutral. The aileron response rate decreases as control wheel rotation increases.

4.1.3.5 Aileron Power Packages

Each of the four ailerons is positioned by a single aileron power package, as shown in figure 15. Two independent hydraulic supply systems provide hydraulic fluid to each package. They are isolated within the package so that with the loss of one system the package will continue to operate. For reliability analysis, the power package is represented as two separate modules, each with its own hydraulic supply system.

Input to each power package is provided by a control linkage and cable runs that are positioned by one of the central control actuators. The input operates through an overtravel mechanism to position a single-spool tandem control valve. The overtravel mechanism compensates for additional input after the valve spool has reached full travel.

Hydraulic fluid from the supply systems is provided to the control valve through filters and check valves that prevent reverse flow in the pressure lines. Positioning of the control valve ports both hydraulic systems to a tandem actuator. As the actuator moves to position the aileron, it also repositions the input linkage to the power package. The follow-up motion closes the control valve when the aileron reaches the desired position as determined by the initial input. If the linkage fails, a bias spring positions the control valve spool to the aileron full-down position.

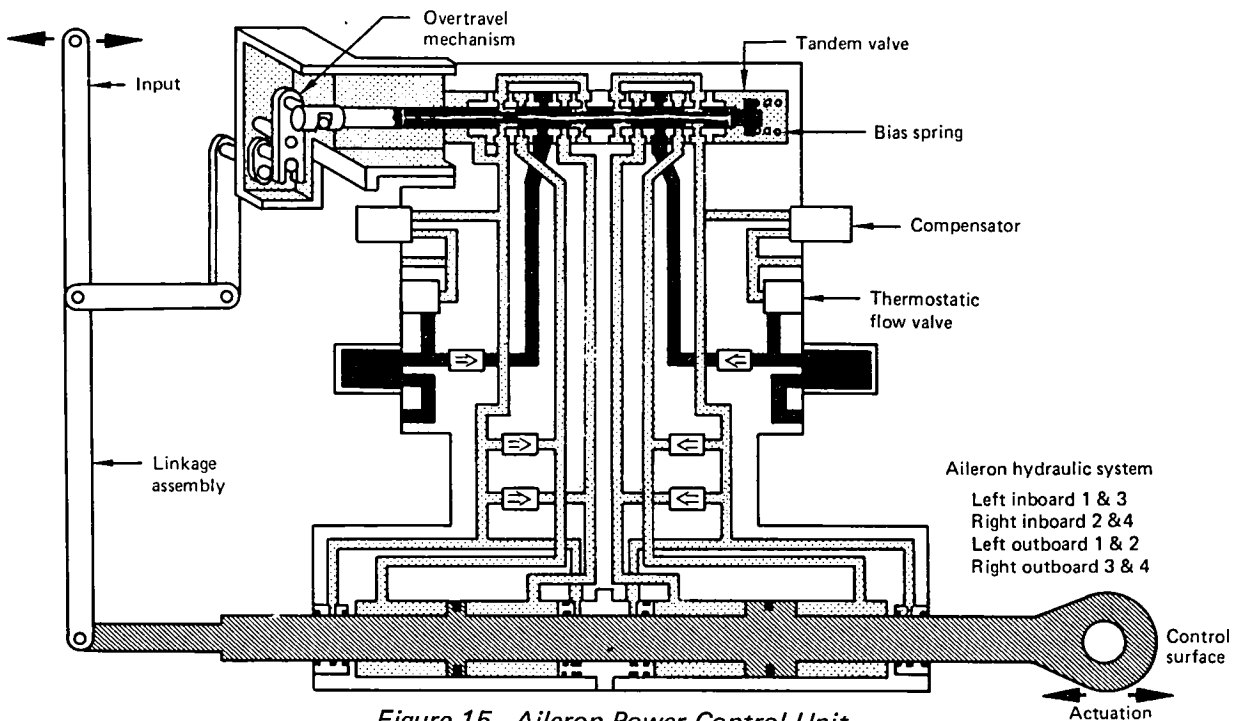

4.1.3.6 Outboard Aileron Lockout System

An outboard aileron lockout mechanism in each wing isolates the outboard ailerons from the lateral control system during high-speed flight. The mechanism consists of a housing, cable quadrant, input crank, output crank, and a series of levers and links. When the components are in certain positions, the mechanism either transmits or

prevents the transmission of motion from the control wheel to the aileron power package. The outboard aileron electric lockout actuator provides the input to the aileron lockout mechanism. The actuator consists of a 28V dc reversible motor controlled by limit switches within the actuator plus an actuator shaft. Electrical power to the actuator is provided through a switch actuated by the outboard trailing edge flap power package.

4.1.3.7 Spoiler Control Differential Mechanisms

Two differential mechanisms, located on the forward wheel well bulkhead, combine the inputs from the central control actuators and the speed brake sequence mechanism to position the flight spoilers (fig. 16). The differential mechanisms allow the flight spoilers to be used to augment lateral control of the airplane, even when simultaneously being used as speed brakes. Each differential mechanism includes a lateral input shaft and a speed brake input shaft plus a right and left output shaft with cable quadrants for cable control inputs to the spoilers.

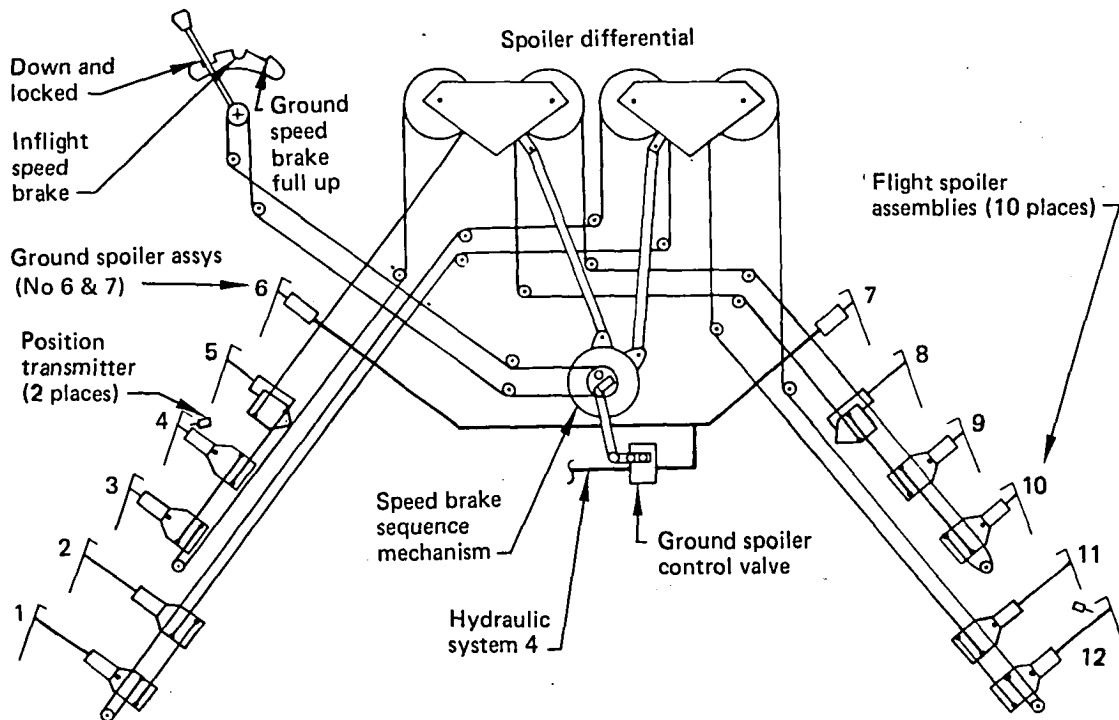

Figure 16. Spoiler Quadrant Schematic

The differential mechanism housing contains the spoiler programming cam plus related levers and linkage. Rotation of the cam programs the lateral control to the spoilers by causing the output cable quadrants to be rotated differentially.

Only a speed brake input to the differential mechanism will raise the flight spoilers on both wings in proportion to actual speed brake input. Simultaneous inputs from aileron and speed brake systems will cause the output quadrants to move in a combined manner, providing lateral control from the flight spoilers with the speed brakes on.

4.1.3.8 Spoiler Power Control Packages

Each flight spoiler power package includes a cable quadrant and linkage for conveying the control input to the control package valve. Certain spoilers are grouped together for simultaneous operation by common cable runs from the differential mechanisms (fig. 16). One cable quadrant of the left differential mechanism controls spoilers 3, 4, and 5; the other controls spoilers 8, 9, and 10. One cable quadrant of the right differential mechanism controls spoilers 1 and 2 and the other cable quadrant controls spoilers 11 and 12.

4.1.3.9 Spoiler Position Indication

Surface position transmitters are installed at spoiler 4 on the left side and spoiler 12 on the right side. The two transmitters provide electrical signals to the position indicator in the control cabin, showing relative displacement and position of the two spoilers. The maximum up position for all flight spoilers is 45 deg, except for spoilers 5 through 8, which is 20 deg.

Functional and reliability block diagrams for the lateral control system are shown in Figures 17 and 18.

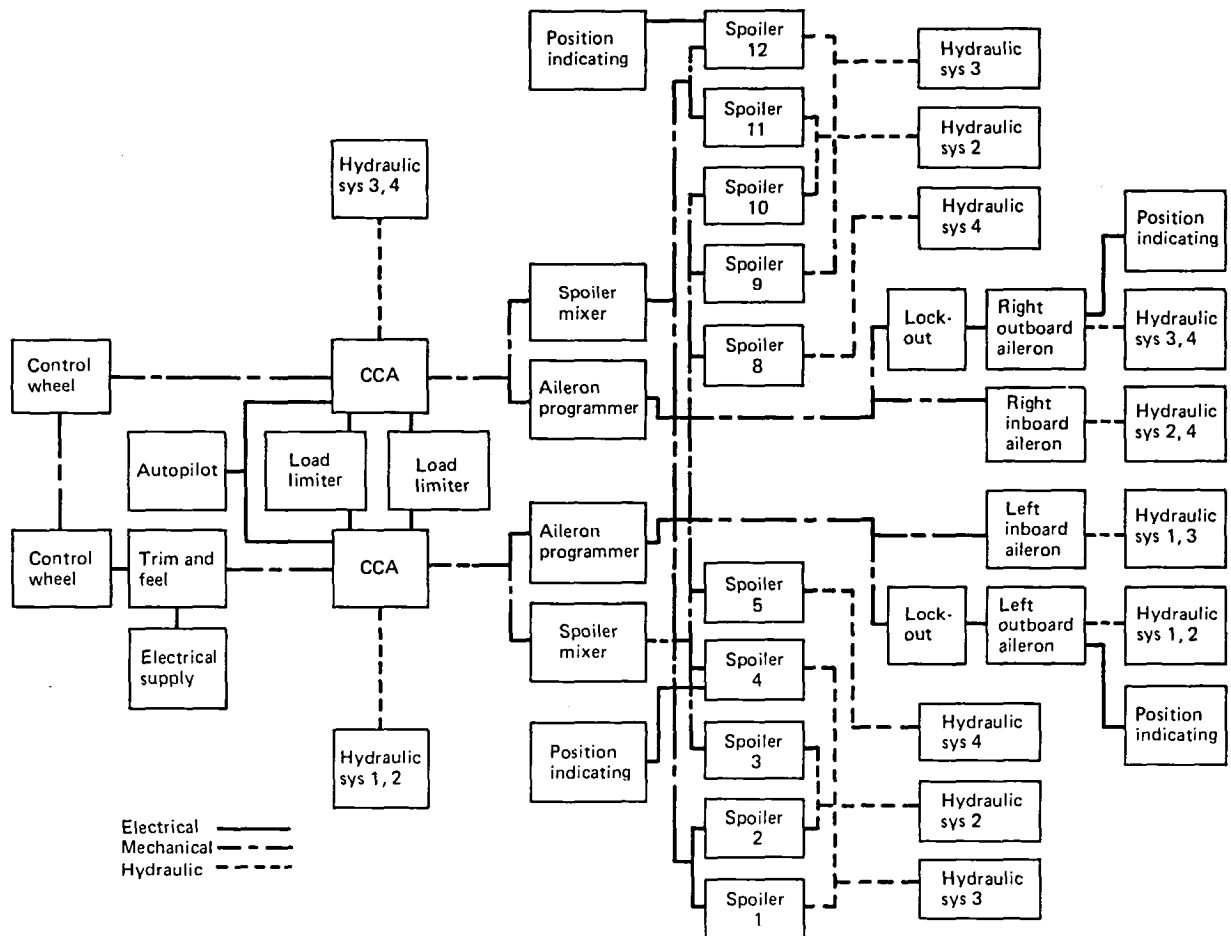

Figure 17. Lateral Control Functional Block Diagram

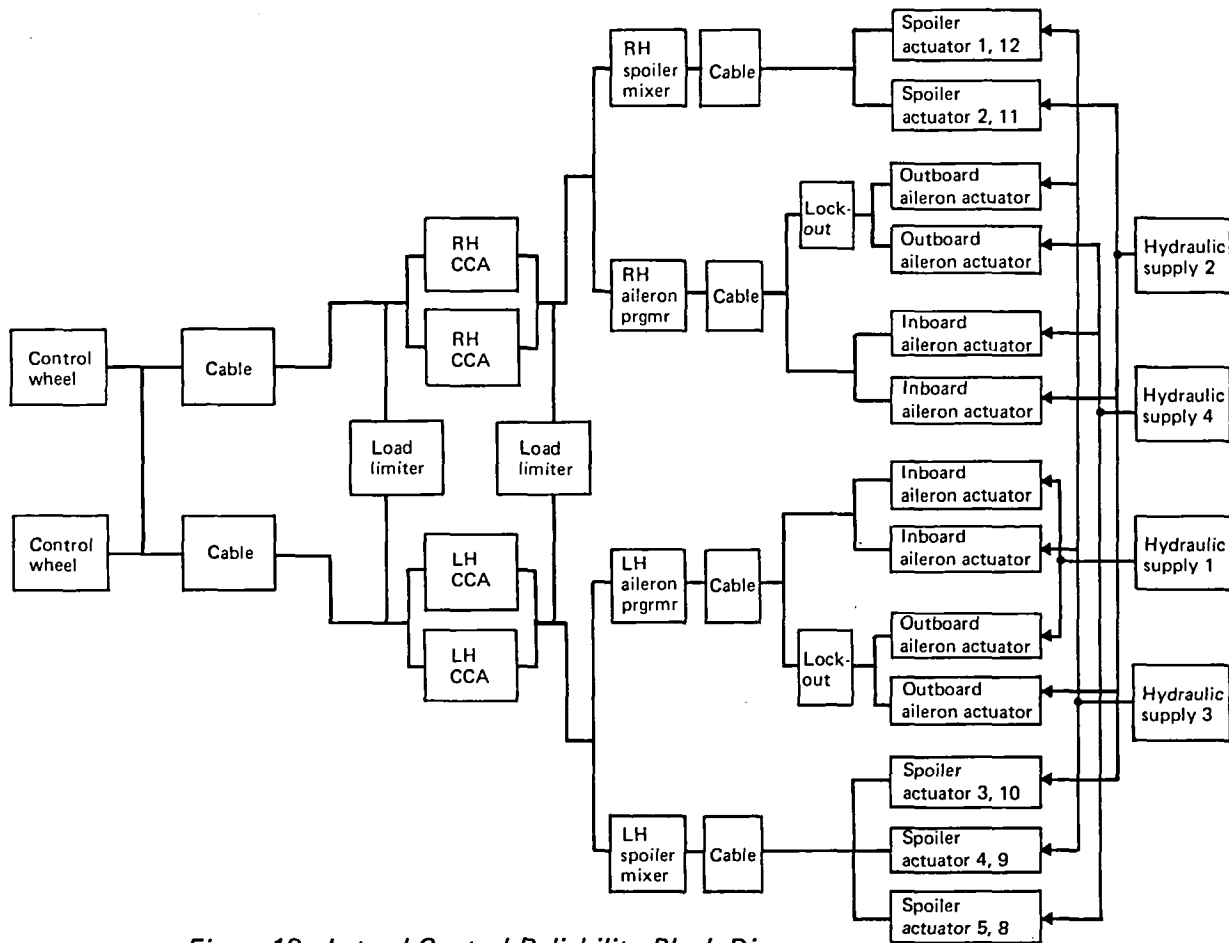

Figure 18. Lateral Control Reliability Block Diagram

4.1.4 Rudder Control

Two hydraulically powered rudders provide directional control (fig. 19). Forward control quadrants and cables transmit rudder pedal motion to an aft control quadrant in the fin. Aft quadrant motion then positions ratio changers to provide input to the rudder power package at each rudder. A yaw damping system also signals the power packages to position the rudders.

The ratio changers in the package input mechanism control available travel of the rudders. Maximum travel of the rudders is available at low speeds and is reduced as airplane speed increases. This is accomplished by changing the ratio of pedal travel to power package input. The ratio changer position is determined by q-pressure from a pitot-static system.

Rudder trim, centering, and artificial feel are provided by a mechanism connected to the aft control quadrant. Rotation of the trim control wheel on the pilot control stand positions the mechanism to give a new system-neutral position, which corrects the trim. A spring in the mechanism provides the centering and feel forces.

The pilots apply mechanical inputs to either set of rudder pedals or to the rudder trim control knob in the control cabin. The autopilot applies electrical inputs directly to the upper and lower rudder power control packages. The functional and reliability block diagrams for the rudder control are shown following the detailed description of the system.

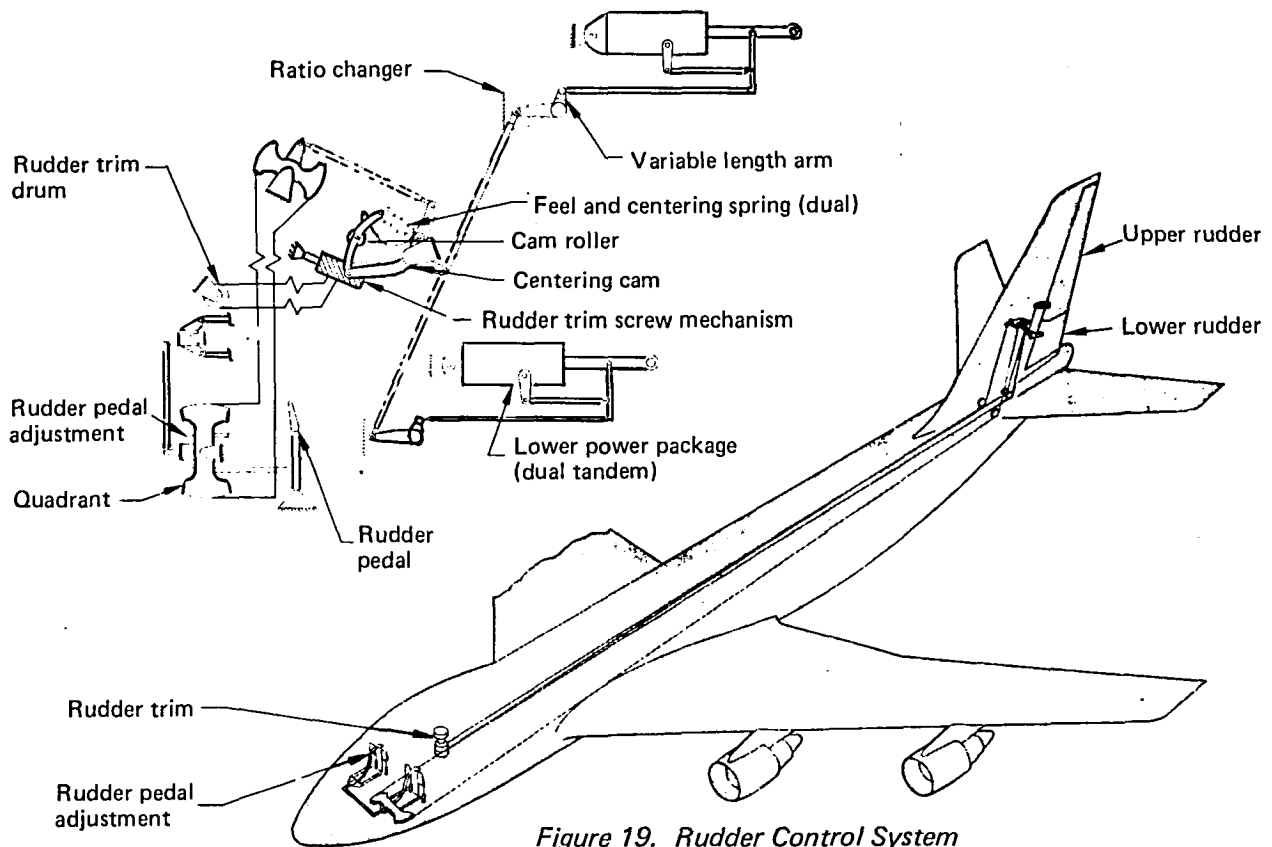

Figure 19. Rudder Control System

4.1.4.1 Forward and Aft Quadrant

Movement of rudder pedals transmits motion to the jackshaft yoke of the forward quadrant by two pushrods. Rotary motion of the jackshaft yoke and forward quadrant moves the aft quadrant through a pair of cables. The rudder aft control quadrant conveys the motion of the rudder control cables to the feel and centering trim mechanism.

4.1.4.2 Rudder Trim System

The control mechanism consists of a rudder trim knob and indicator on the aft end of the control stand and a cable drum attached to the knob through a vertical shaft (fig. 20). Movement of the trim knob rotates the shaft and drum, which is connected by cables to the rudder trim actuator.

The rudder trim actuator converts cable motion into a linear force, which is applied to the rudder feel and centering mechanism. The actuator assembly consists of a cable drum and jackscrew nut, actuator housing, and screw. Rotation of the cable drum moves the drum and nut plus the actuator housing linearly on the screw. A thrust bearing, located in the upper end of the actuator, transfers the jackscrew nut forces to the actuator housing. Movement of the actuator housing causes the feel and centering assembly to rotate, which shifts the null of the centering mechanism to provide ± 16 deg of rudder trim. As the pedals are displaced progressively from neutral, the rudder feel and centering mechanism applies a progressively increasing centering force to the control system. When pedal force is removed, the centering mechanism returns the pedals and rudder to their neutral positions. All components of the feel and centering mechanism are of a dual load path design to ensure that no single failure will result in the loss of the trim system or in the loss of rudder centering.

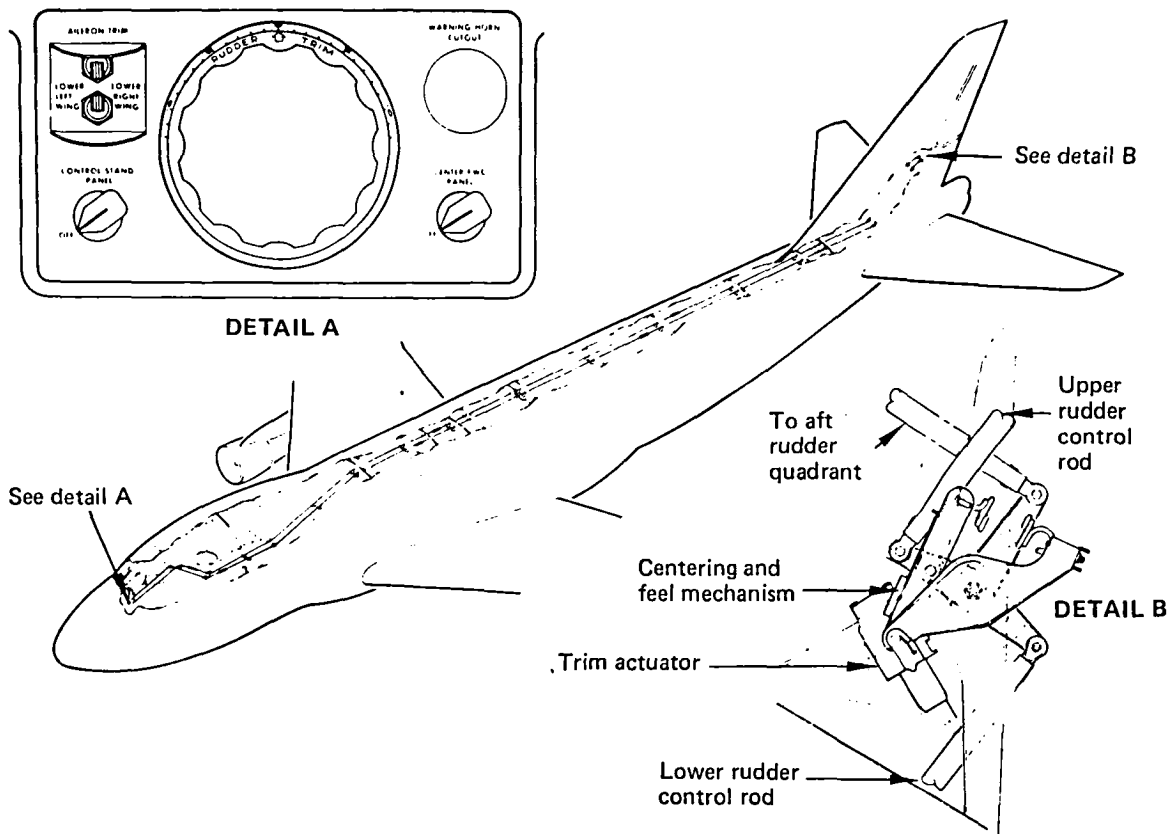

Figure 20. Rudder Trim System

4.1.4.3 Rudder Ratio Changer System

Each of the upper and lower rudder ratio changer systems shown in figure 21 is composed of a control unit and a ratio changer (servo unit), interconnected electrically to form an electromechanical closed servo loop. A comparator continuously monitors the servo unit positions of both ratio changers. Each control unit contains a pressure transducer, amplifier, switching circuit, and internal power supply. Each servo unit contains an actuator, electric motor, and positional potentiometer.

Both ratio changer control systems are installed in the vertical fin close to their associated power control packages. The rudder ratio changer control system consists of an input crank, trunnion, output crank, and a servo unit. The control unit is activated by a variable air pressure input applied at the q-pressure port. Mechanical input and output linkages connect the servo unit to the feel and centering unit and to the rudder power control package. The comparator unit compares the positions of the two servo units and provides a signal whenever the positional relationship of the two servo units is out of tolerance. The comparator supplies excitation voltage for two potentiometers and compares their signals. When the signal difference is excessive, the comparator turns on the rudder ratio warning light on the instrument panel.

If the ratio changer fails to respond to changes in airspeed, the warning light will illuminate, indicating that the two ratio changer actuators are not at the same positions. One rudder will have either too little or too much authority, depending upon

whether the airplane speed has increased or decreased after the failure. When making rudder inputs, the pilot will monitor the rudder position at high speeds to avoid excessive rudder displacements.

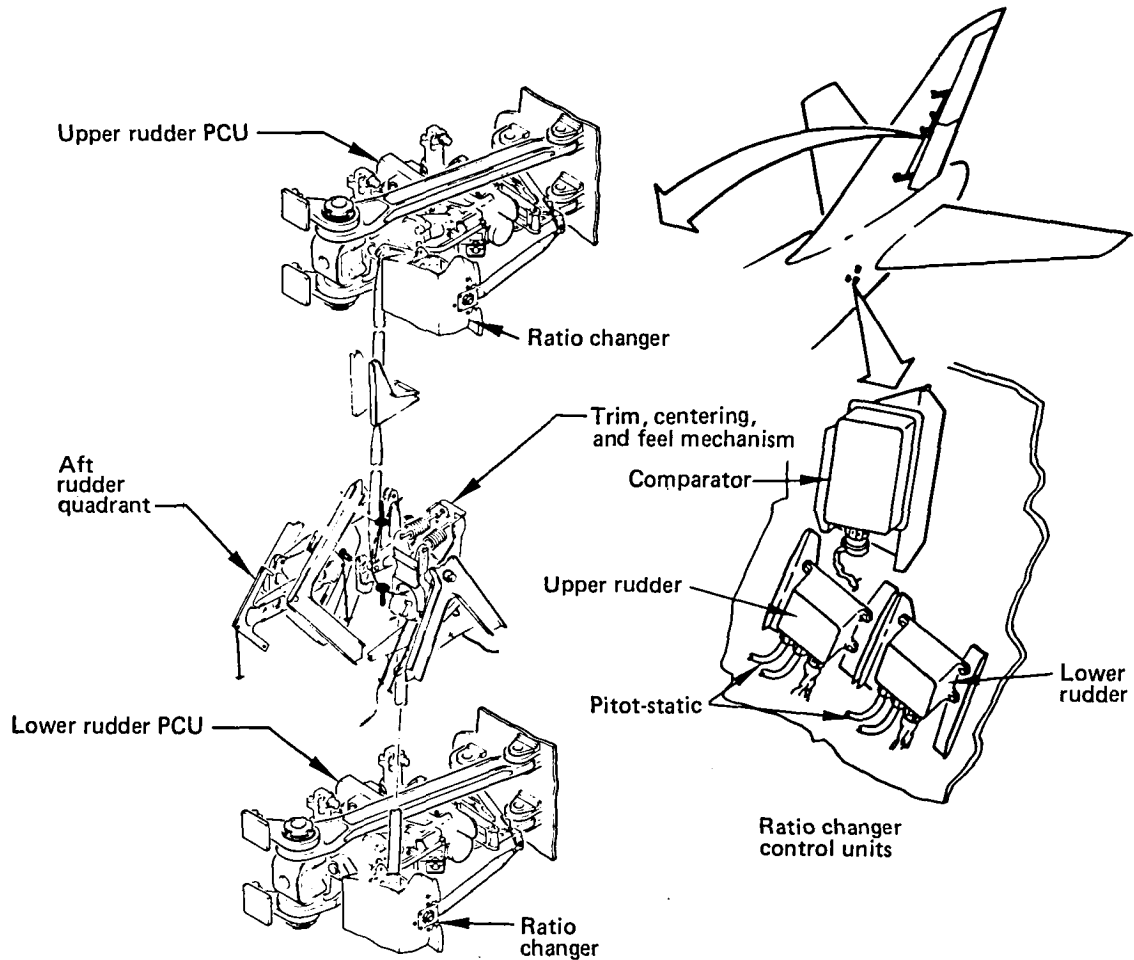

Figure 21. Rudder Ratio Changer System

If the ratio changer actuator inadvertently extends or retracts fully because of an electrical failure, the following will result.

- 1) The ratio changer warning light illuminates.
- 2) If the ratio changer actuator extends, the authority of one rudder will be greatly reduced at low speeds.
- 3) If the ratio changer actuator retracts, one rudder will have excessive authority at high speeds. Pilot response would be:
 - o No action required if the ratio changer extends.
 - o Monitor the rudder position at high speeds if the ratio changer actuator retracts.

For this study, such failures are not considered to cause a loss of rudder control function.

4.1.4.4 Rudder Power Control Packages

Each rudder power control package consists of a dual-tandem hydraulically driven actuator with integral control components (fig. 22). Two separate hydraulic systems supply each power control package: airplane hydraulic systems 1 and 3 supply the upper rudder package and systems 2 and 4 supply the lower rudder package.

In manual operation, the lower and upper rudder power control packages function similarly. On each package, pressure from both associated hydraulic systems is applied to two separate pressure ports. The functions performed by both systems are identical, but complete hydraulic isolation is maintained between the two systems. An

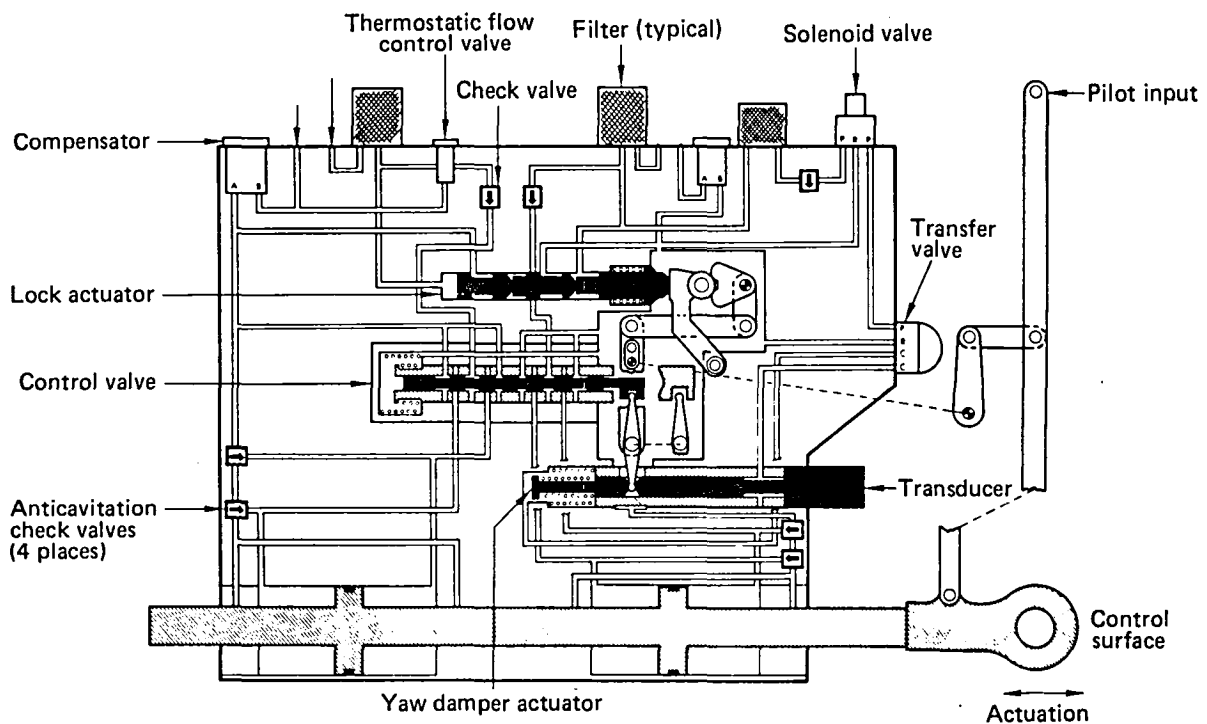

Figure 22. Rudder Power Control Unit

autopilot module on each package provides an alternative means of operating the control valve electrically. The module contains a transfer valve, solenoid valve, and position transducer for interface with the yaw damper channel.

Rudder pedal and trim input is transmitted to the power control package rotary input shaft through the external summing lever, drag link, and input lever. The input shaft rotates, actuating the dual concentric servo valve plungers.

The actuator control valve is dual concentric so that, if the primary spool jams, the secondary sleeve can be used to close the valve or vice versa.

Feedback, provided through the input summing lever and input drag link assemblies, returns the servo valve plungers to neutral. Hydraulic pressure equalizes on both sides of the tandem actuator pistons and arrests further motion. During normal operation,

the internal linkage pivot point is maintained by pivot lock pistons exerting force against a locking cam. If the servo valve of one power control package becomes jammed, the internal linkage will rotate the locking cam, thus allowing input to the other rudder power control package.

Rudder control functional and reliability block diagrams are shown in Figures 23 and 24.

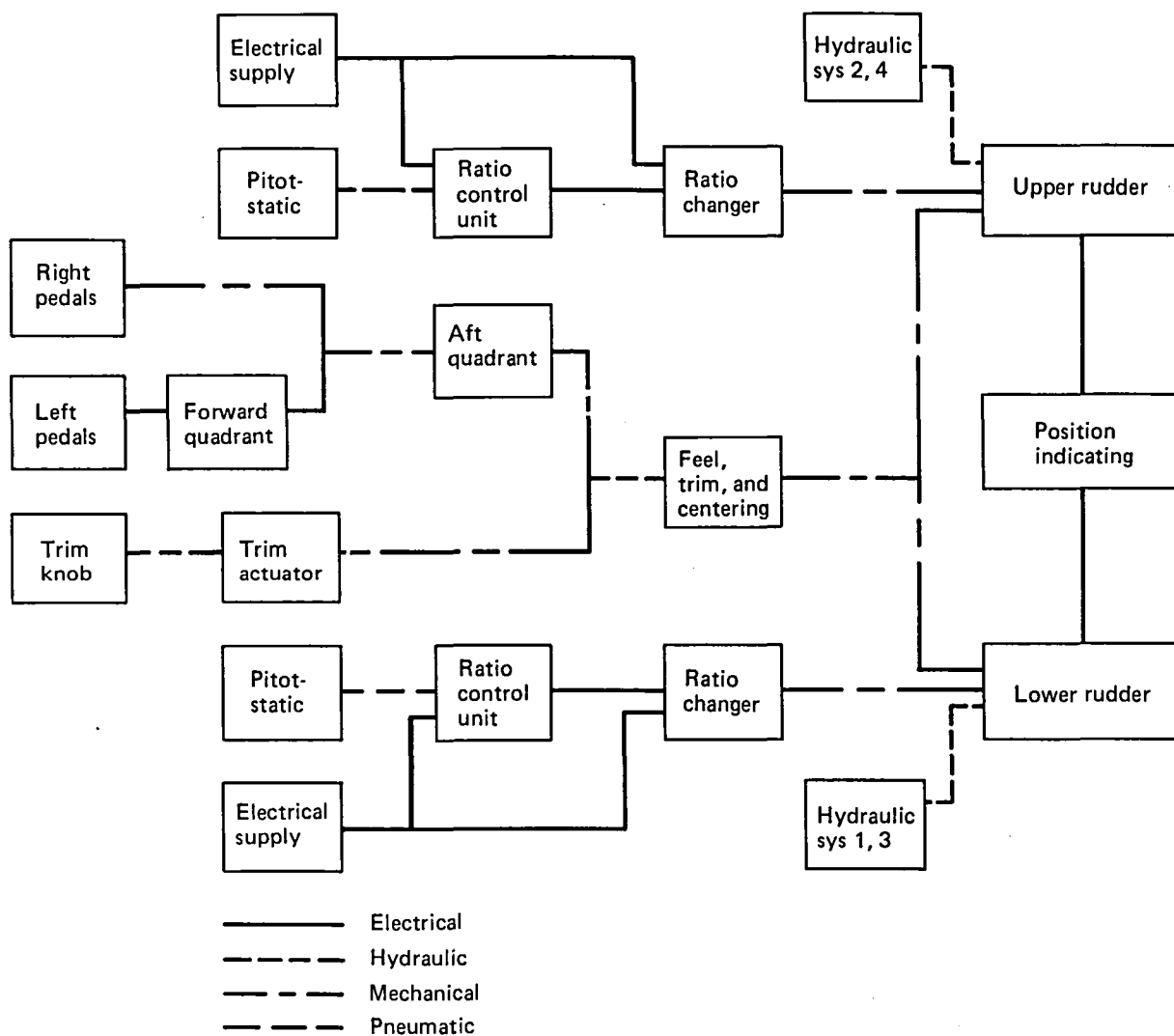

Figure 23. Rudder Control Functional Block Diagram

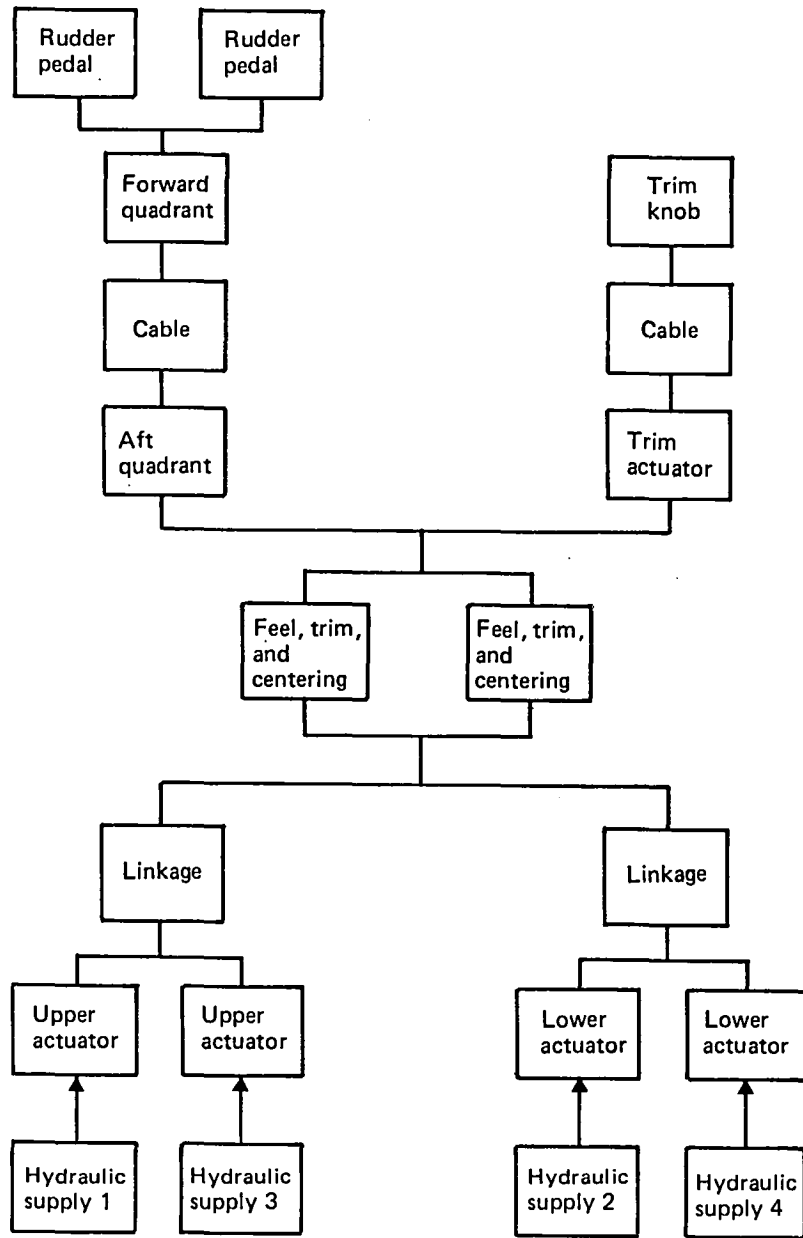

Figure 24. Rudder Control Reliability Block Diagram

4.1.5 Speed Brakes

The speed brake control system increases drag and reduces lift both in flight and on the ground. The system consists of 12 spoiler panels (numbered 1 through 12), a power control package for each spoiler, speed brake control lever, drum mechanism, sequence mechanism, ground spoiler control valve, and cables and pulleys to operate the system. The five outermost spoilers on each wing are flight spoilers and the two remaining spoilers (6 and 7) are ground spoilers.

The speed brake control lever located on the left side of the pilot control stand (fig. 25) controls the system. The flight spoilers use hydraulic systems 2, 3, and 4 while the ground spoilers use hydraulic system 4. The fully raised position is 45 deg for spoilers 1 through 4 and 9 through 12; it is 20 deg for spoilers 5 through 8.

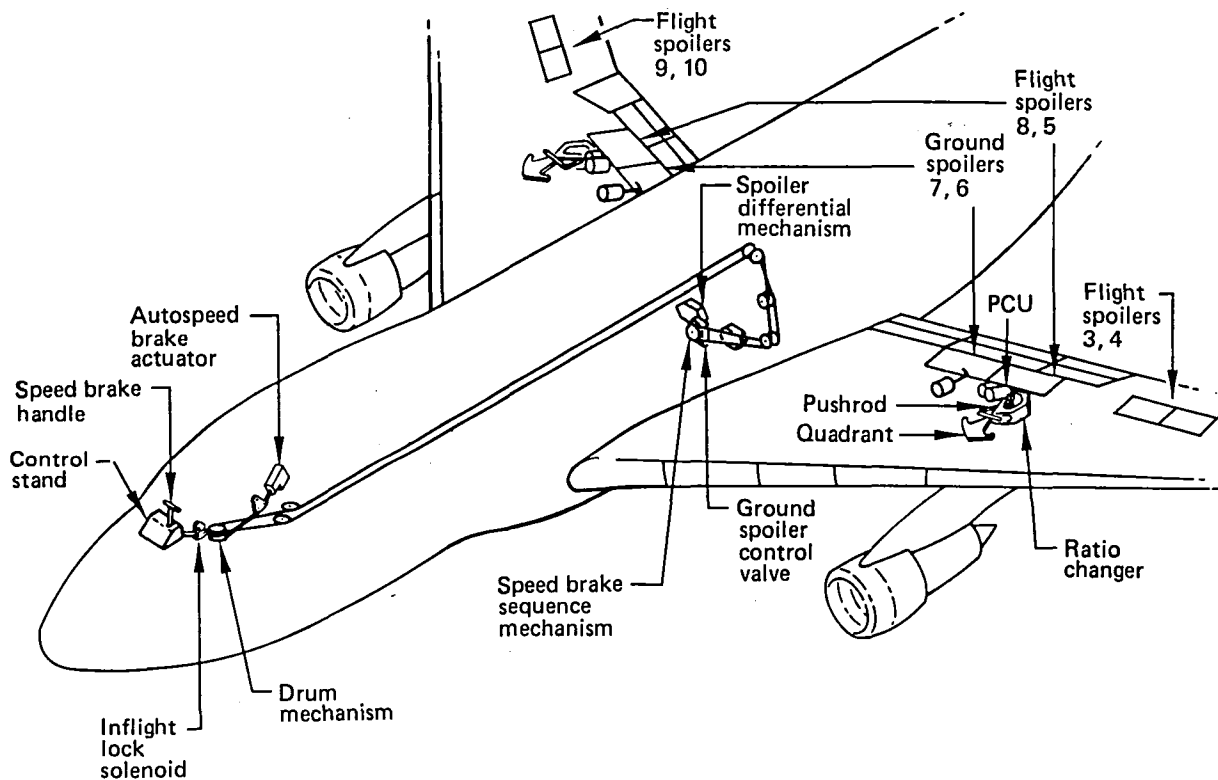

Figure 25. Speed Brake System

When using spoilers as speed brakes in flight, spoilers 3 through 10 are used. When the speed brake control lever is moved to the FLIGHT stop, these spoilers are moved from faired to full travel. A solenoid-operated stop at the speed brake crank under the cabin floor arrests the speed brake control lever at the FLIGHT DETENT position during flight.

4.1.5.1 Speed Brake Control Lever

The speed brake control lever, located on the left side of the pilot control stand, is coupled by linkage to the speed brake drum mechanism and by cable to the speed brake sequence mechanism.

4.1.5.2 Speed Brake Drum Mechanism

The speed brake drum mechanism consists of a cable quadrant and an irreversible mechanism. The mechanism permits the main shaft to rotate in response to inputs from the speed brake control lever. It prevents the main shaft from rotating in response to the torque applied at the cable drum side. A cam is provided on the drum with a detent for the ARMED position. A spring-loaded roller arm follows the cam and provides speed-brake-control-lever feel at this point.

4.1.5.3 Speed Brake Sequence Mechanism

The speed brake sequence mechanism receives the cable quadrant input from the speed brake control lever and programs an output to operate the flight and ground spoilers. The mechanism consists of a cable pulley, two input cranks connecting control rods to the spoiler control differential mechanisms, a crank connecting a control rod to the spoiler control valve, and a housing assembly. The housing assembly contains a mechanism that programs the positioning of the spoilers as speed brakes when the speed brake lever is placed in the UP position. The speed brake mechanism is located in the right wing-gear wheel well.

Two other output lever arms provide input to the spoiler control differential mechanisms to operate the flight spoilers as speed brakes. The output from the sequence mechanism results in an output to the differential mechanism to activate flight spoilers 3, 4, 5, 8, 9, and 10 for speed brake use in flight.

The reliability block diagram for the speed brakes is shown in figure 26 and the functional block diagram is shown in figure 27.

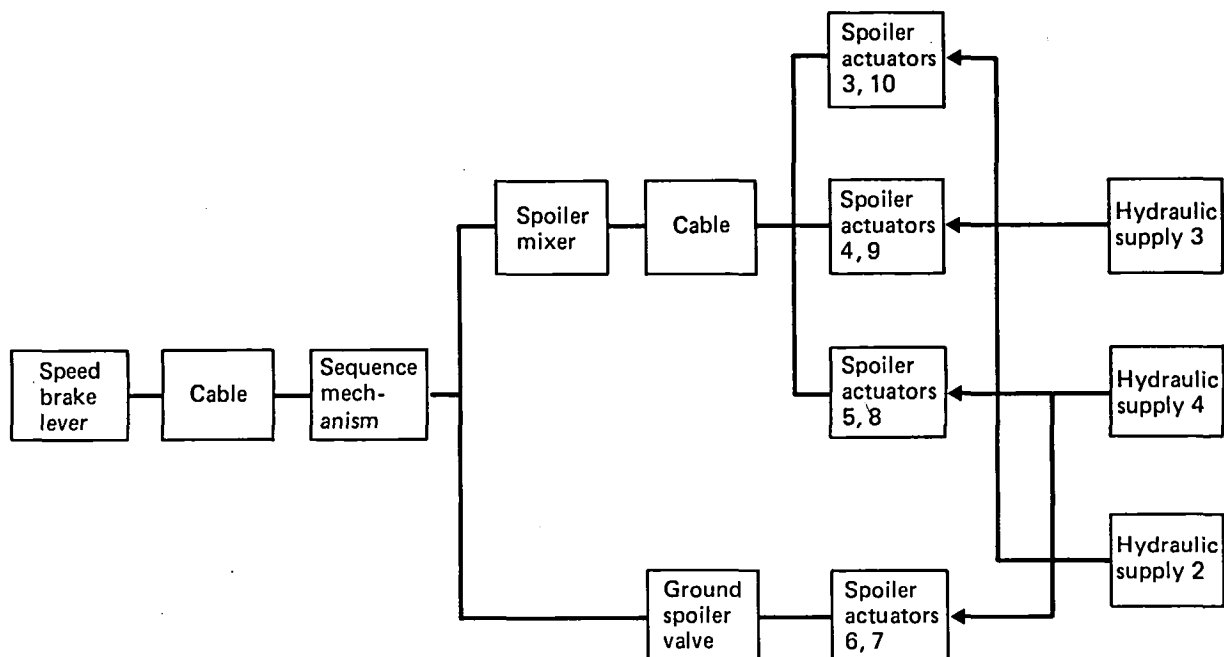

Figure 26. Speed Brake Reliability Block Diagram

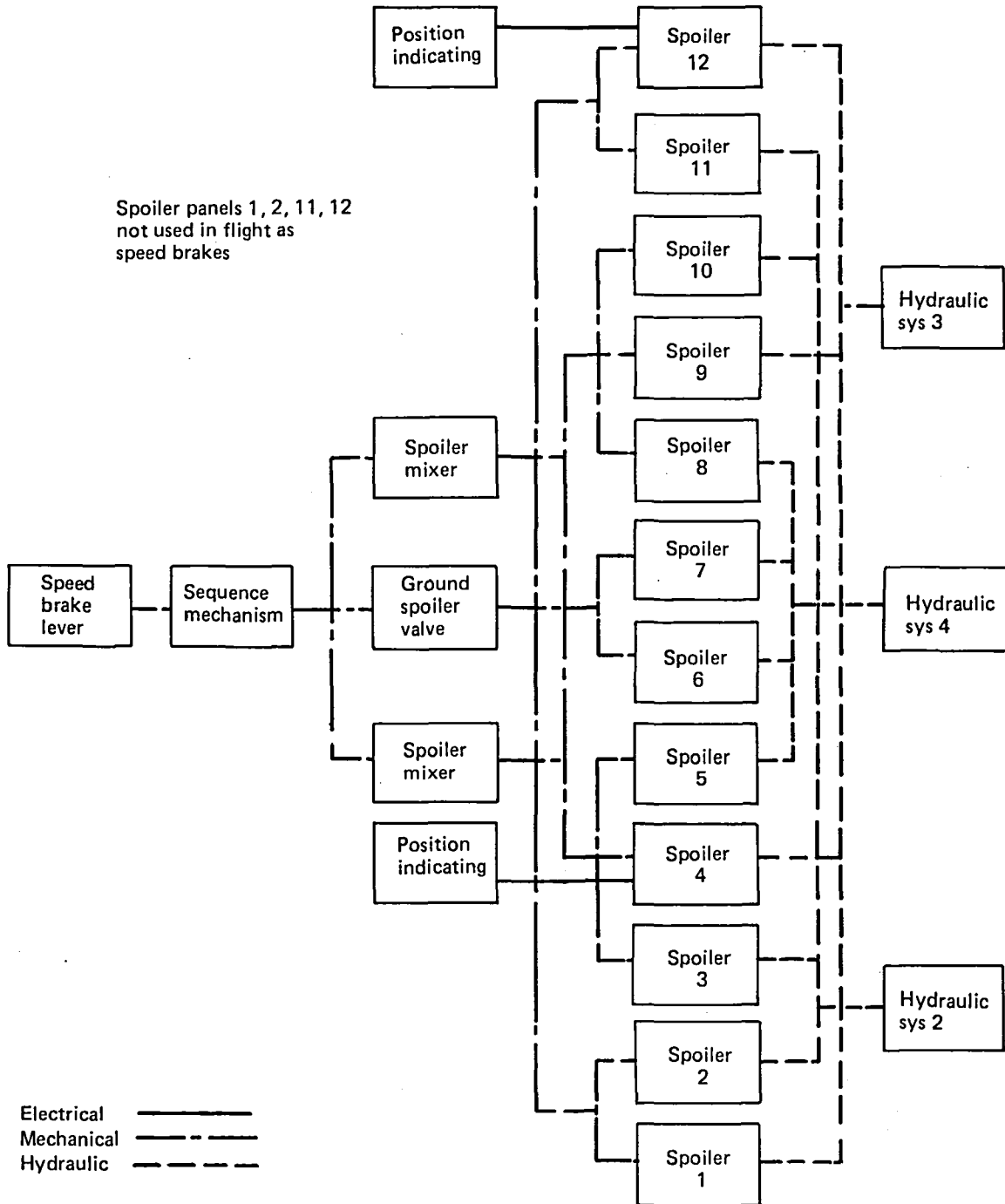

Figure 27. Speed Brake Functional Block Diagram

4.1.6 Hydraulic Power Supply

The model 747 has an unusual degree of hydraulic source redundancy and load transfer ability. Four independent primary hydraulic systems each relate to a different main engine, and each has two pumps in parallel that are interchangeable. One pump is mechanically driven by the engine, while the other is driven by bleed air from any or all main engines or from the auxiliary power unit (APU). This pump redundancy enables dispatch of the airplane with an air-driven pump inoperative. Hydraulic system 4 also contains an ac motor-driven pump that can operate with electrical power from APU generators or ground sources.

The hydraulic sources operate the systems shown in figure 28. Each primary function and most individually actuated elements are powered by at least two hydraulic sources. For example, all four main sources are normally available to control yaw, pitch, and roll.

Each main hydraulic system has a fluid reservoir that is pneumatically pressurized for positive pump feed without pump cavitation. Emergency gravity flow is assured by the position of the engine-driven pump, which is directly below the reservoir. A reservoir negative-g trap ensures continuity of supply during downward acceleration.

All reservoirs are filled with fire-resistant hydraulic fluid at one main wheel well location. This location provides a hand pump and suction line, ground cart pressure-fill connection, and reservoir selector valve and quantity indicator.

Hydraulic system filtration includes separate case drain filters, which permit fault isolation and keep contamination out of the system. Pressure filters have no bypass and have large dirt-holding capacity. Large return filters permit operation "on condition" up to excessive pressure indication without danger of bypassing. All filters in the power generation system include ΔP indicators.

4.1.7 Electrical Power Supply

Primary electrical power is provided by four generators powered through constant-speed drives from the engines and normally working in parallel to supply four main ac buses.

Alternatively, primary power can be supplied on the ground by two onboard APU generators or by ground power via two external connectors (fig. 29). All six generators are identical 3-phase, 400-Hz, 115/200V units. The generators are brushless units, rated for 60 kVA when engine driven and for 90 kVA when APU driven. Four identical 75A transformer-rectifiers convert ac power to 28V dc at four buses. The dc power is used throughout the airplane to supply control circuits. A 34-Ah battery provides standby power sufficient to permit continued flight with the primary sources inoperative.

The system is designed for dispatch with one engine generator inoperable. A high degree of source redundancy and selectivity is provided for all loads. Such flexibility in isolating or paralleling generators ensures operational continuity and easy fault location. To prevent accidental fault prolongation, each breaker remains free to trip during any attempt to close into a fault.

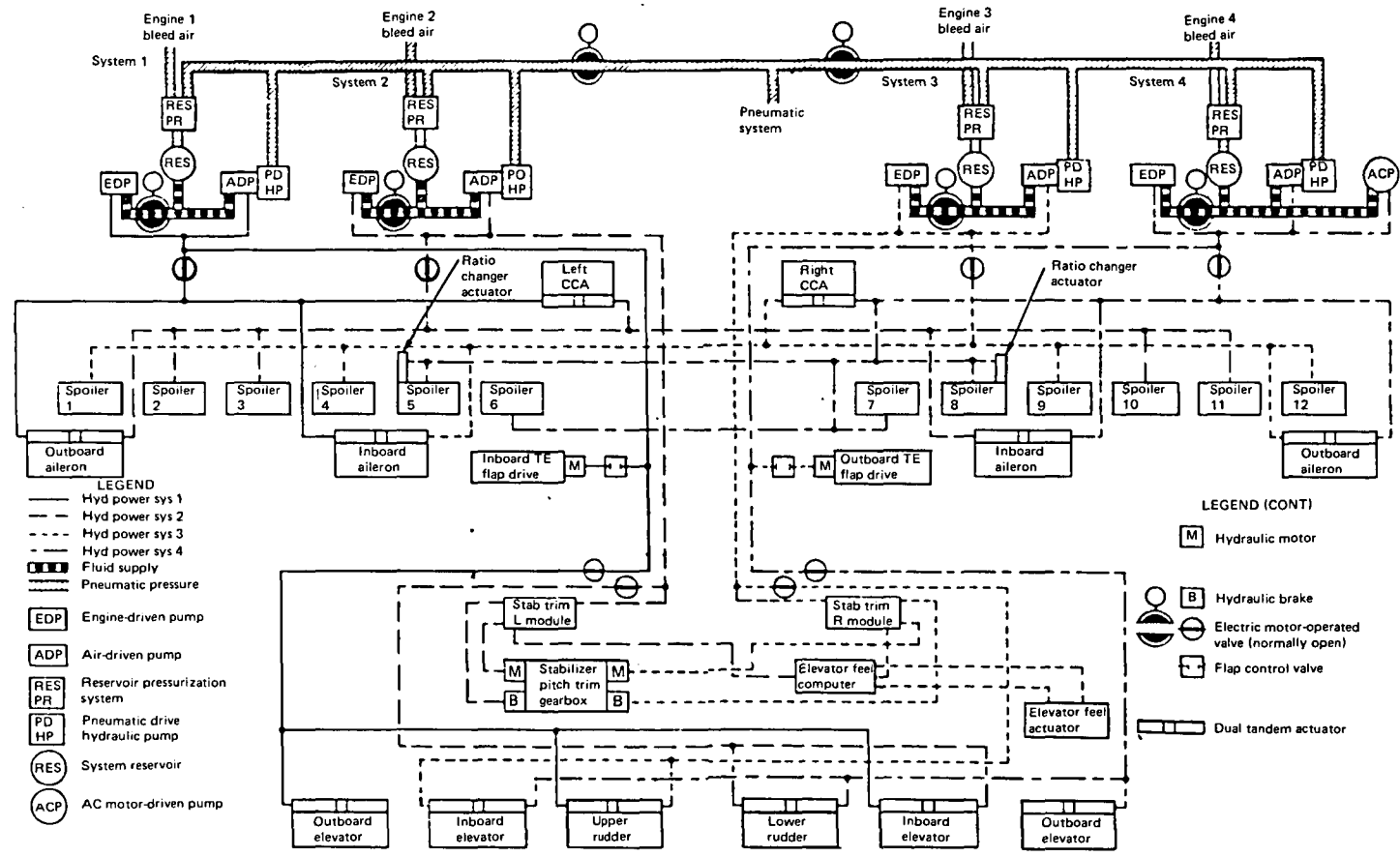

Figure 28. Flight Control Hydraulic System

APU = auxiliary power unit
 Ess = essential
 TRU = transformer-rectifier unit
 APB = APU breaker
 BTB = bus tie breaker
 GCB = generator breaker
 XPC = external power connector

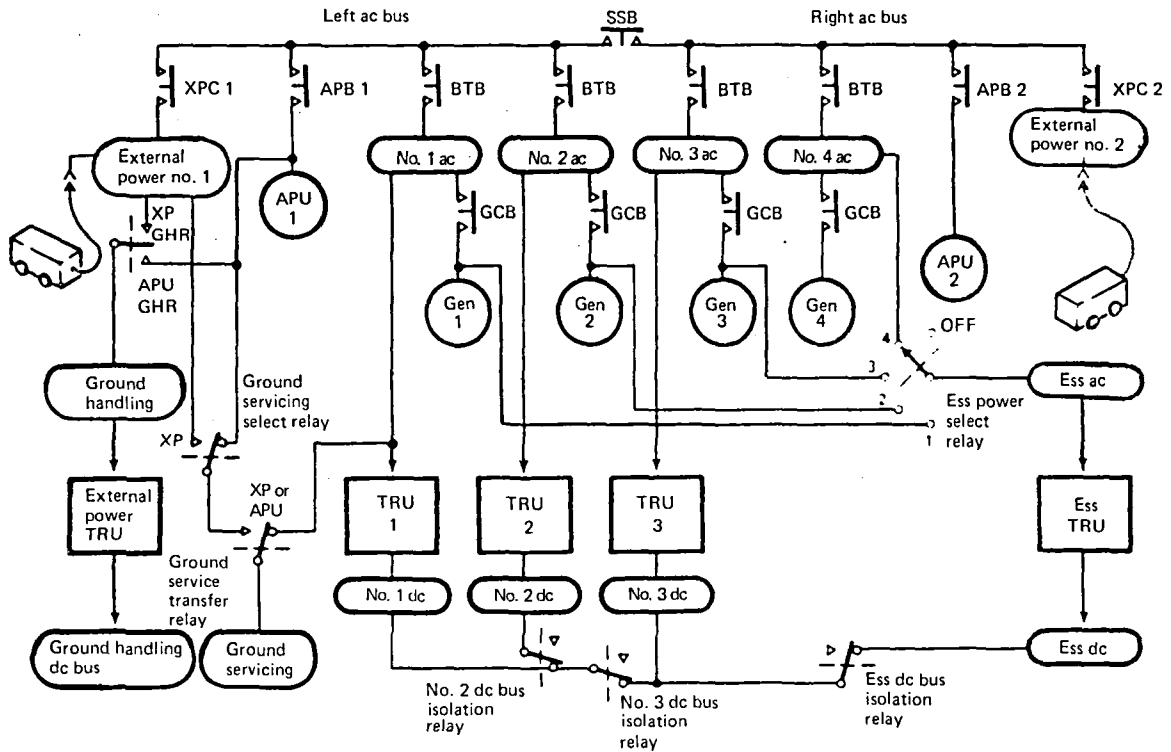

Figure 29. Electrical Power System

An "essential ac" bus is normally connected to main bus 4, but alternatively is switchable directly to generators 1, 2, or 3. With this arrangement, any combination of one, two, or three inoperable generators can be sustained without loss of power for the essential bus.

If all generators are deenergized, the main battery can supply the standby bus loads for at least 30 min. Another battery, identical to the main battery and located forward of the APU firewall, is used for starting the APU.

4.2 RELIABILITY ASSESSMENT

4.2.1 Analysis Methodology

The first step in the methodology consists of determining the functions and interactions of the various components in the system. This was accomplished in the system description (sec. 4.1). That section reveals how the PFCS operates, permitting the construction of functional block diagrams and reliability block diagrams.

The next step in the analysis is to use the block diagrams as tools to assemble system models for a specific analysis technique. A reliability analysis technique was not developed for this study because of a specific requirement to use a technique, computer-aided redundant system reliability analysis (CARSRA), developed during a previous study (ref. 1) involving system reliability of advanced flight control designs. This analysis will be used to establish a baseline contemporary flight control system against which future applications can be assessed. The use of the same reliability model would be advantageous for comparing system modeling and results.

The CARSRA program description and users guide are included in appendix A. The output from the computer program is functional readiness and failure probability. Functional readiness is the probability of retaining a function at a certain time assuming the system is initially fully operational. Failure probability is computed from a given functional readiness criterion as a function of time.

The CARSRA program requires that the system be precisely defined using Markov models, Markov transition rates, and system dependency trees, as illustrated in figure 30.

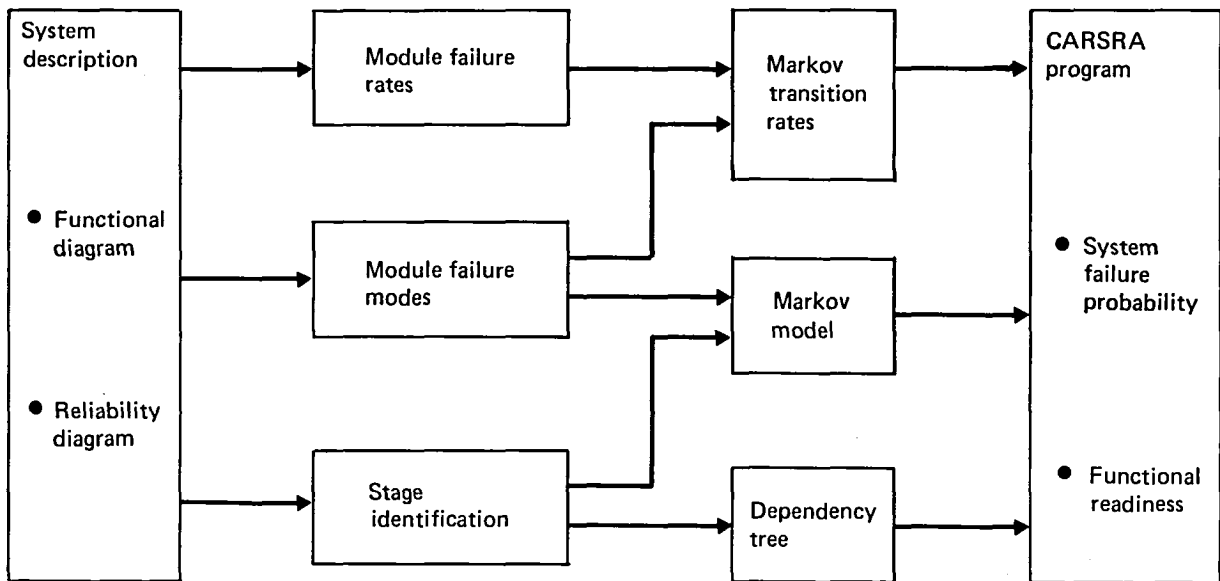

Figure 30. System Modeling for CARSRA Program

Markov transition rates are established from module failure rates and module failure modes. The failure rates for each of the modules or line-replaceable units identified in the description, and the failure modes for each module, are calculated from airline component reliability reports. The calculation of these rates is shown in section 4.2.3.

The modeling of a flight control system involving conventional cables and linkage plus hydromechanical power control actuators represents a departure from the modeling of advanced flight controls involving sensors, computers, and servos cross-strapped in various ways. To see the relationship between modeling of conventional flight controls and modeling of a computer-controlled concept, an example of each is shown in figures 31 and 32. Each example is a control system providing actuation to a pair of control surfaces.

The system modeling task begins with partitioning the system into stages where a stage has been defined as a set of identical redundant modules. Referring first to the computer control model (fig. 31), the stages identified are the sensors, computers, and each set of servos; in this case, each stage has three modules. The second step consists of defining the dependency structure in the form of a dependency tree diagram. A dependency exists whenever the operational status of a module in a particular stage depends on the operation of modules in other stages. Here, dependency exists between a computer and servo, and the lines drawn from modules in stage B to stages C and D show where the dependencies exist. Because the sensors are cross-strapped to the computers, no dependency exists and the sensor stage is shown as three nondependent modules.

Markov models are drawn for each stage as the next step. The computer control example represents a triplex system that is considered two-fail operational and may degrade to duplex and simplex operation. The term two-fail operational refers to a system that can remain operating after two successive and unrelated failures.

For each Markov state, a corresponding fault rate λ determines the probability of exiting the state due to a single fault. Specifically, the amount of time the stage spends in that state is an exponentially distributed random variable with mean equal to the reciprocal of λ . For example, consider the four states for the sensor stage: operating with none failed, operating with one failed, operating with two failed, and not operating (three failed). If the failure rate of each module is λ , then the exit rate from the none-failed state is $3\lambda (= \lambda_{1-2})$. Similarly, the exit rate from the one-failed state is $2\lambda (= \lambda_{2-3})$, and from the two-failed state is $\lambda (= \lambda_{3-4})$.

The Markov model for the computer stage shows four states: three success states, and one failure state. The CARSRA program is able to handle another failure state, which is an undetected failure not shown here for simplicity. There is no single-point failure mode shown in the model by the absence of a transition from state 1 to the failed-state 4. Thus, the system is assumed to survive all possible single failures. The transition from state 2 to state 4 indicates that some second failures may cause stage failure. Otherwise, the computer stage will tolerate a second failure and the system will remain operational.

Coverage is the conditional probability that, given failures, a stage continues to perform the required function. An array of coverage values or parameters is critically important in the determination of the functional availability and mission reliability.

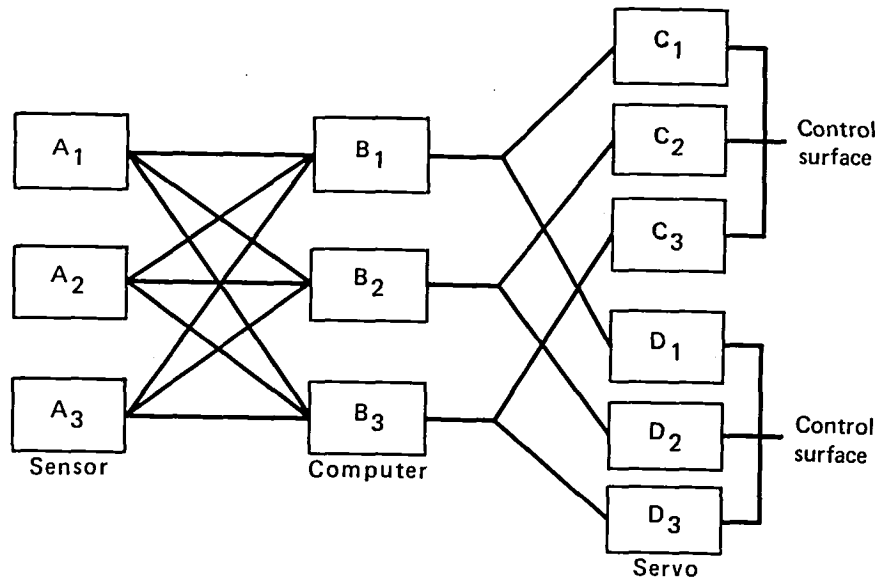

RELIABILITY BLOCK DIAGRAM

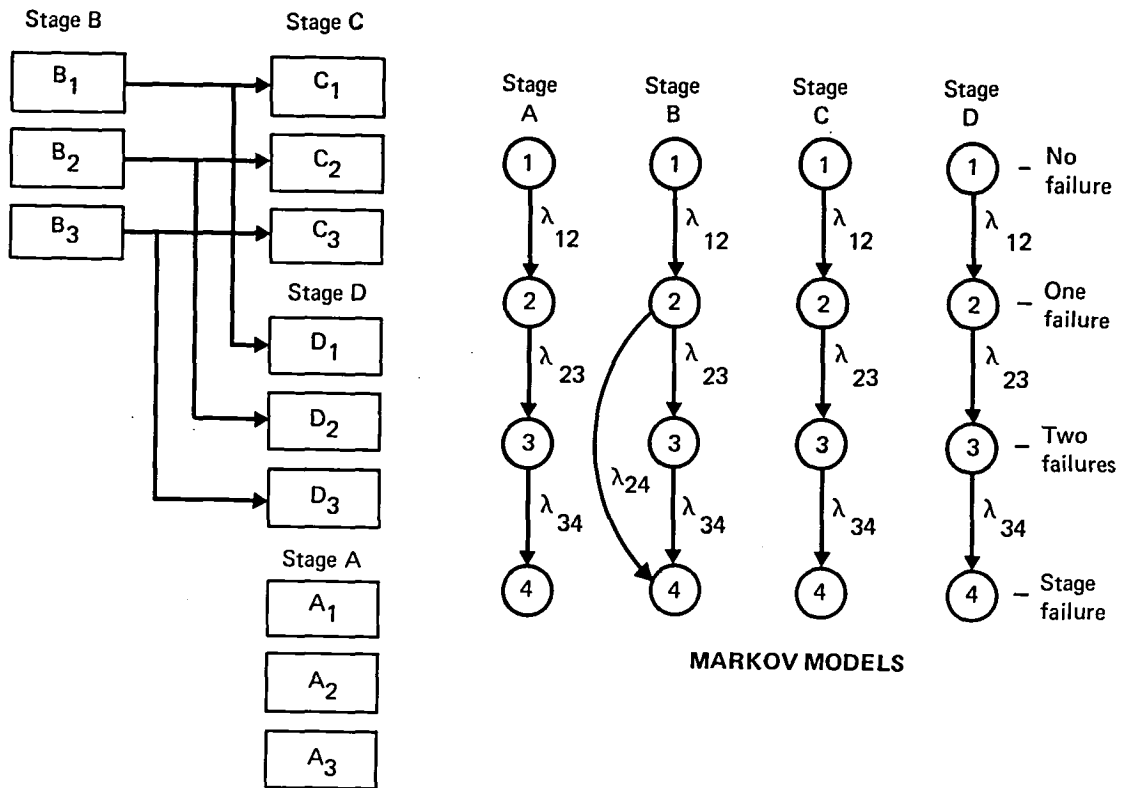

DEPENDENCY TREE

MARKOV MODELS

Figure 31. Computer Control System Model

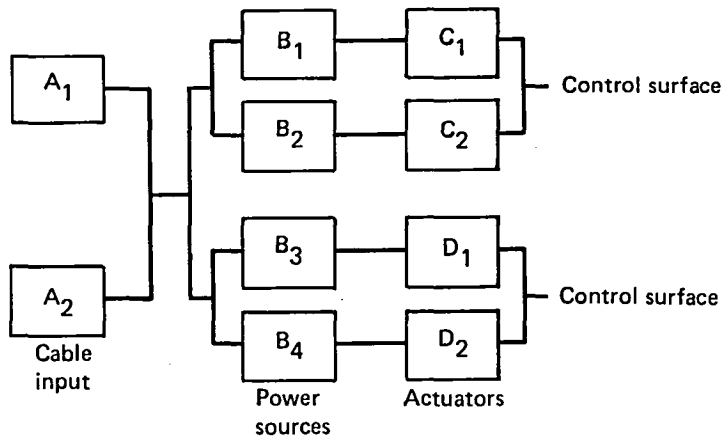

RELIABILITY BLOCK DIAGRAM

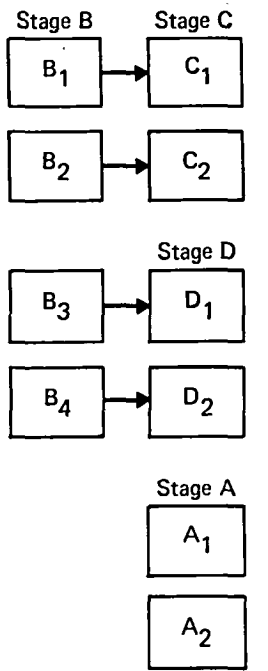

DEPENDENCY TREE

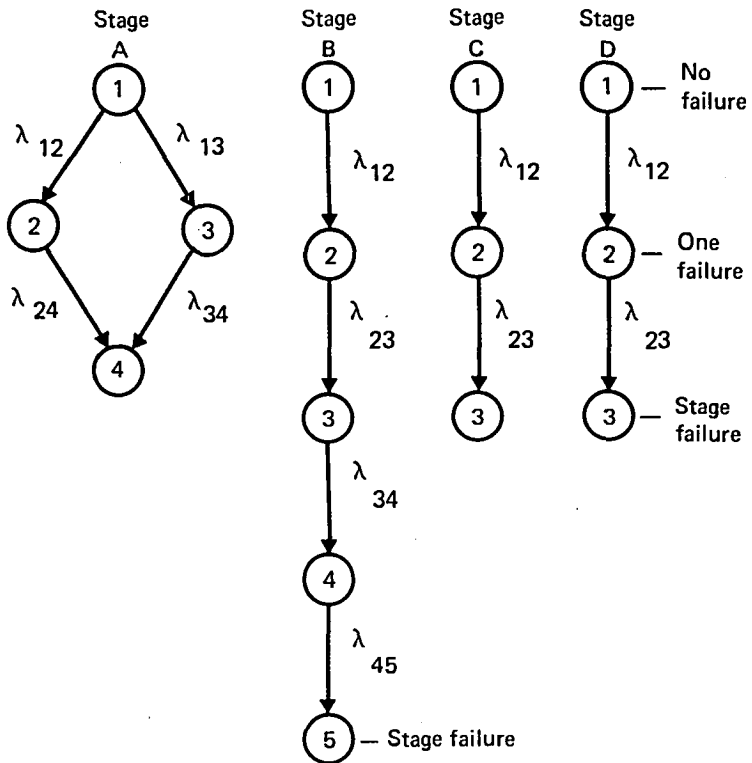

MARKOV MODELS

Figure 32. Mechanical Control System Model

In the computer stage, a second failure from state 2 can be tolerated only if it is detected and isolated to achieve successful redundancy degradation to state 3 or simplex operation. The percentage of second failures that are successfully detected and isolated is the second-failure coverage.

The final step consists of establishing the success criteria for system operation. In this case, it is assumed that control is acceptable if only one control surface is operating. CARSRA will model this situation by accepting a success event tabulation covering all nondependency stage combinations equivalent to system success.

The modeling steps for the mechanical control system example shown in figure 32 are identical to the computer control system example. Stage identification includes one stage for the four independent power sources, one stage for each actuation package serving the respective control surfaces, and one stage for the control cable inputs. The control cable input stage contains modules having different failure rates. CARSRA has the capability to handle this situation although the airborne advanced reconfigurable computer system (ARCS) concept was confined to stages having identical modules. Dependency exists between power source modules and actuator modules; the dependency tree shows this. The cable inputs form a nondependent stage because the input to a control surface actuation channel can come from either input module. The Markov model shows five failure states for the power source stage. If success criteria establish that control is acceptable with only one control surface operating and that the actuator stages are each one-fail operational (able to operate after one failure), then the power source stage can suffer three module failures; i.e., fail to state 4 before stage failure to state 5. The identification of coverage

parameters is not significant here because the power sources are independent of each other. A first, second, or third power source failure need not be detected and isolated because there is no need to identify and vote out the failed source; each failure is passive and there is no transition to state 5 from states 1, 2, or 3. The Markov model for the cable input stage shows four states, but only one failure state exists before stage failure. It is assumed for this example that the failure rate or transition rate for each input A_1 and A_2 are different. This can be the case if one input is by main pilot control and the other input is by a trim cable system. Failure order then dictates this form of the Markov model. If A_1 fails first, followed by A_2 , transition is from state 1 to state 2 for A_1 failed and transition from state 2 to state 4 when A_2 fails. Transition from state 1 to state 3 to state 4 occurs when A_2 fails before A_1 .

In general, a system can be modeled in more than one way by grouping different modules in a stage to suit a particular success configuration. Usually, it is desirable to combine as many modules as possible in a stage, if the success configurations can be maintained and the Markov models are not too large. CARSRA is limited to nine failed states in the Markov model and 20 different success configurations.

A feature of CARSRA is the ability to assess functional readiness as well as system failure probability. The concept of functional readiness is useful for a flight containing a critical subtask that will either be performed or not depending on the operational redundancy level at the time of demand. An example is the category II autoland function of the automatic flight control system. For this example, a functional readiness criterion is established that specifies what elements of the flight control system can fail without losing the autoland function. The system functional readiness for selected module failure patterns is computed by CARSRA and represents the probability that category II autoland will be available at the end of a flight.

Speed brake deployment is a subtask that may be required at a particular phase of flight for the primary flight control system (PFCS). Speed brakes are often used to reduce airspeed when a pilot must make a rapid descent as part of an air traffic control maneuver. The functional readiness of the speed brake system will be assessed at the descent phase of the flight.

4.2.2 Control Function Definition

In the model 747, all flight control surfaces are power actuated. High multiplicity of power sources, command paths, power actuators, and control surfaces has eliminated manual reversion. There are 23 structurally independent, movable control surfaces (not including the high-lift devices): four ailerons, four elevators, two rudders, a horizontal stabilizer, and 12 spoilers.

4.2.2.1 Control Inputs

The primary control cabin controls for surface movement are two conventional control columns, two control wheels, and two sets of rudder pedals. Control surface actuation can also be accomplished by the trim system, which is available in all three control axes. Another source that maintains control in flight is the input from the autopilot and yaw damper system. However, for this study, the analysis includes only the mechanical controls available to the pilot and copilot.

4.2.2.2 Actuation and Power Sources

Each aileron, elevator (except the outboard elevator), and rudder is driven by two independent hydraulic sources. The identity of these sources varies from surface to surface and is available from four different pairings of the airplane's four hydraulic systems. As a result of these assigned energy sources, airplane control around each of the three axes (roll, pitch, and yaw) is powered by all four hydraulic systems. In normal operation, hydraulic systems 2 and 3 have no assignment other than flight control. They are, in that sense, the basic flight control energy supplies. However, even if both of these primary systems were to fail, the source redundancy is such that the aileron, elevator, and rudder sections could still be moved.

The degree of redundancy in the 747 PFCS establishes that airplane control can be maintained with loss of some input control, power sources, and actuation to control surfaces. For the reliability analysis, a failure definition is established governing a combination of control surfaces that are required to maintain the control function. These control functions are defined in table 1, including the required inputs, power sources, and surfaces. For simplicity, the terms 1/3 I/B and 1/2 O/B used in the table refer to one-third of all left and right inboard spoiler surfaces, and one-half of all left and right outboard spoiler surfaces. Figure 12 shows the location of the inboard and outboard spoilers, and the reliability diagram in figure 18 shows the pairing for left and right spoilers.

The definitions (table 1) for each control function do not identify absolute control minimums. It could be, for example, that only one inboard elevator is operating in the elevator control system. Whether adequate control can be maintained will depend on factors such as availability of other flight controls, the center-of-gravity position, and engine-out possibilities. Because the reliability analysis is confined to each separate control function, these definitions are considered appropriate for each control function. The reliability results will, therefore, show the probability of not maintaining a control function and not necessarily the probability of losing control in that particular flight axis.

Table 1. Control Function Definitions

Control system	Operation of these surfaces	Hydraulic power sources required	Control inputs required
Elevator control	<ul style="list-style-type: none"> ● One inboard and one outboard or ● Both inboard 	At least two	Control column
Stabilizer trim	<ul style="list-style-type: none"> ● Stabilizer surface 	At least one	Mechanical or electrical
Lateral control*	<ul style="list-style-type: none"> ● For high-speed case, one of these: <ul style="list-style-type: none"> ● Left inboard aileron and (1/3 inboard or 1/2 outboard spoiler) ● Right inboard aileron and (1/3 inboard or 1/2 outboard spoiler) ● Left and right inboard ailerons ● 1/2 outboard and 1/3 inboard spoilers ● For low-speed case, one of these: <ul style="list-style-type: none"> ● Left inboard and outboard ailerons and (1/3 inboard or 1/2 outboard spoilers) ● Right inboard and outboard ailerons and (1/3 inboard or 1/2 outboard spoilers) ● Left and right inboard or outboard ailerons ● 1/2 outboard and 1/3 inboard spoilers 	At least two	Control wheel
Rudder control	<ul style="list-style-type: none"> ● Upper or lower surface 	At least one	Rudder pedal or trim
Speed brakes	<ul style="list-style-type: none"> ● 1/3 inboard and ground spoilers or ● 2/3 inboard spoilers 	At least two	Control lever

*For the lateral control function, the outboard ailerons have not been included because they are locked out during most of the flight. However, as a check, the failure probability for the low-speed case is also computed and the failure definition includes the availability of the outboard ailerons.

4.2.2.3 PFCS Definition

The model 747 basic design includes surfaces that provide primary flight control: the elevators, ailerons, and rudders. These surfaces control the airplane about the pitch, roll, and yaw axes. The stabilizer trim is not considered a primary pitch control system and provides only trim in this axis. The spoilers are secondary control surfaces in relation to the ailerons. As speed brakes, the spoilers do not provide control about any axis. The PFCS is defined in table 2, including the required inputs, power sources, and surfaces.

Table 2. PFCS Function Definitions

Control system	Operation of these surfaces	Hydraulic power sources required	Control inputs required
PFCS	<ul style="list-style-type: none"> ● One inboard and one outboard elevator or ● Both inboard elevators and ● Left or right inboard ailerons and ● Upper or lower rudder 	At least two	<ul style="list-style-type: none"> ● Control column and wheel and ● Rudder pedals or trim

4.2.3 Component Reliability

The system reliability evaluation requires that failure transitions be assessed in each of the stage modules that make up the system model. Transition rates are determined from module failure rates, failure mode, and system operating characteristics. For this study, a module is identified as a component or series of components that perform a function.

Component failure rates and failure modes are available primarily from airline records at the line-replaceable unit (LRU) level. In some cases, an LRU may include an assembly of components. In such cases it will be necessary to refer to airline overhaul shop records to identify specific components.

4.2.3.1 Airline Records

The method used to obtain or derive module failure rates is to research airline technical reports. The airlines produce reports to show trends in mechanical operating performance and also to keep track of material usage, i.e., the frequency of component replacements. One such report is the unscheduled component removal report. The unscheduled removal rate is obtained from this report for most items identified in the functional block diagram in the system descriptions, section 4.1.

The objective is to derive the functional failure rate for each component, which then forms the basis of the transition rate in the reliability model. Functional failures include only modes of failure that are considered to result in a loss of function. The flow diagram in figure 33 indicates what steps are necessary to determine the functional failure rate.

Information provided in the component removal reports shows the number of unscheduled removals in a given time period plus the removal rate as a function of the flight-hours flown for that period. Some components may have been removed during troubleshooting, not because they failed. For this study, only justified removals (removals caused by failure) are of interest. In many cases, the airline report will indicate the percentage of justified removals.

The failure rate is the product of the removal rate and the proportion of justified removals. However, more information is required about the justified removal before a functional failure rate can be derived. The failure modes must be identified and categorized into functional failures and nonfunctional failures. This information is available in airline shop records. The functional failure rate is then the product of the failure rate and the proportion of functional failures.

4.2.3.2 Component Removal Rates

The reliability of the mechanical elements in the flight control system is generally much higher than the flight control electronics. Component removal data must, therefore, be collected over a long time span. Appendix B includes removals, hours, and removal rates for the major flight control LRU's. The data base is an assembly of several separate airline reports that goes back to the start of model 747 service in 1970 and extends through 1976. Removal rates used in this study are the cumulative rates. Where the trend shows a marked improvement for any component, the average of the past 4 years is used. For most components, a justified removal percentage is also shown. The justified percentage is not available for components with very low

removal rates; therefore, all removals are considered justified, unless other available reports show otherwise. Removal rates for each control system and the percentage of justified removals are summarized in table 3.

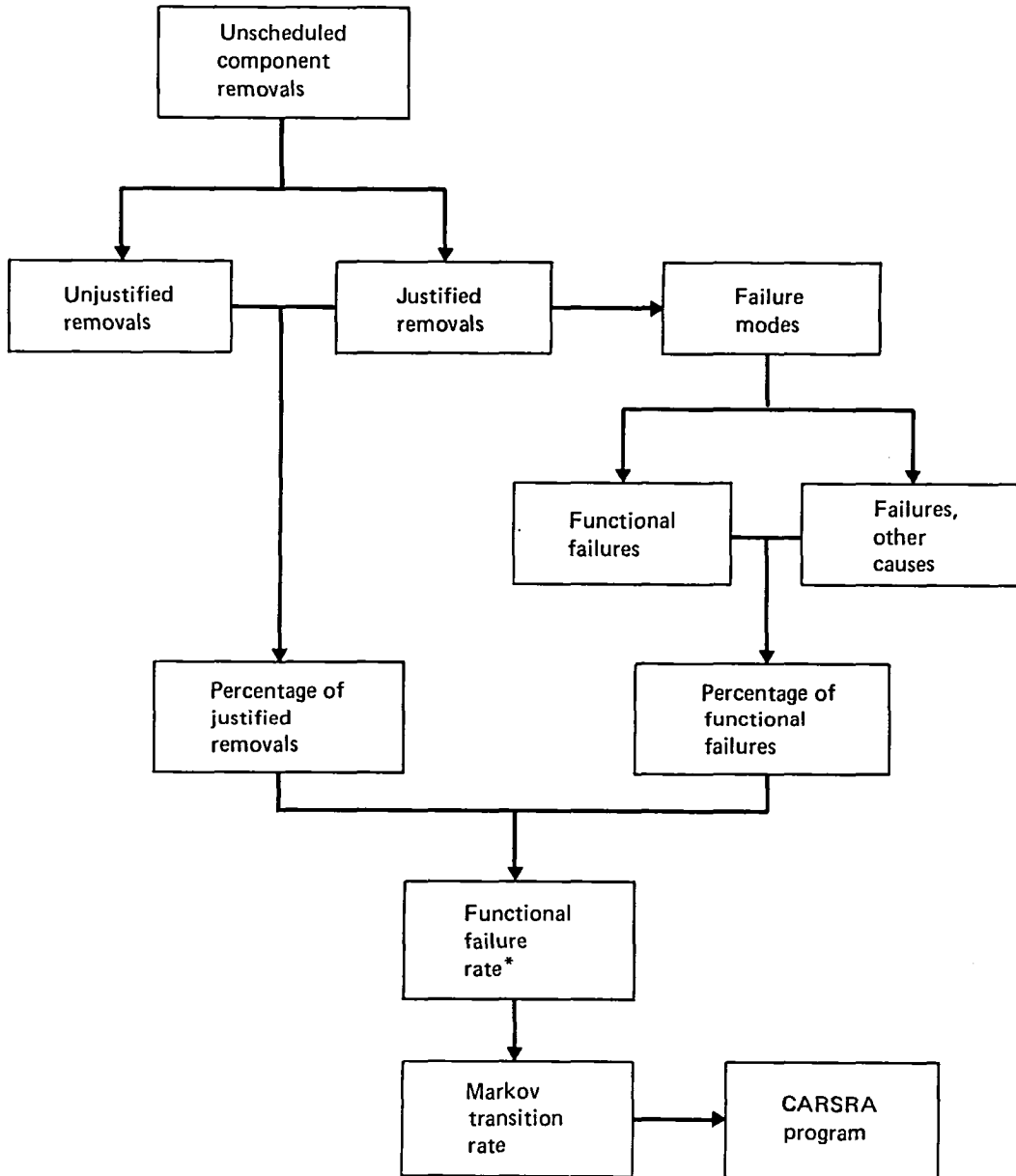

* Functional failure rate = unscheduled removal rate x percentage of justified removals/100 x percentage of functional failures/100

Figure 33. Functional Failure Rate Determination

Table 3. Summary of Airline Component Removal Rates

Component	Removals per 10 ⁶ unit hours	Justified removals (percent)
Elevator		
Control column	0	
Aft quadrant	0	
Feel unit	1.6	100*
Feel actuator	16.8	100*
Feel computer	62.7	84
Inboard power control unit	62.8	93
Outboard power control unit	17.0	100
Stabilizer trim		
Hydraulic motor	20.4	100*
Gear drive	0.6	100*
Hydraulic brake	1.7	100*
Shutoff valve	6.5	100*
Control module	28.7	100
Lateral control		
Control wheel	0	
Trim and feel mechanism	0.9	100*
Trim actuator	13.0	100*
Central control actuator	30.0	61
Aileron programmer	0.4	100*
Spoiler differential (mixer)	0	
Load limiter	0	
Inboard aileron power control unit	37.1	100
Outboard aileron power control unit	22.3	100
Outboard aileron lockout actuator	8.0	100*
Outboard aileron lockout gearbox	1.7	100*
Flight control shutoff valve	6.6	100
Inboard spoiler power control unit	15.3	80
Outboard spoiler power control unit	14.0	92
Rudder		
Feel trim and centering mechanism	0	
Aft quadrant	1.7	100*
Ratio control unit	161.3	52
Ratio changer actuator	111.9	44
Ratio changer comparator	186.5	100
Power control unit	57.7	94
Trim actuator	3.6	100*
Speed brakes		
Control lever	3.3	100*
Sequence mechanism	1.2	100*
Ground spoiler control valve	2.4	100*
Ground spoiler actuator	9.7	100*

* The removals for these components was assumed 100% justified.

4.2.3.3 Functional Failure Rate Analysis

To develop functional failure rates from failure modes and component failure rates, the overhaul workshop findings and maintenance and flight inspection frequencies must be used with prediction analyses.

Mechanical Elements—These elements of the system seldom fail. Functional failure rates are determined in the following two ways. In cases where airline reports

indicate zero removals for mechanical elements, yet preflight checks detect a failure, a functional failure rate of zero is used. In cases where an airline does not report the removal record for mechanical elements, and a review of other records does not show any removals, yet there are regular inspection intervals, a functional failure of 1/3 is used. This figure is obtained from the reference 2 reliability paper, which provides an estimate for the exponential failure rate from data with no failure events. This 1/3 failure can be applied over the accumulated 747 flight time.

Mechanical control failures	= 1/3
747 flight-hours to December 1977	= 5,300,000 hr
Functional failure rate	= 0.06 failure/10 ⁶ hr

This failure rate is conservative; each mechanical item is exposed to regular maintenance inspections and all reported removals were considered justified.

Cables—Control cables are used for the main control paths from the pilot control column and rudder pedals; for trim in roll, pitch, and yaw; and for interconnecting with multiple surface actuation as in spoilers and outboard elevators. The functional failure modes for cables and associated pulleys are cable breakage, pulley breakage, cable-pulley jamming from foreign objects, and cable jamming from ice. Experience with cables on the 747 has been excellent. Just one incident has been reported to the FAA. This was ice accumulation on an aileron cable, which prevented surface actuation. Actuation was possible later in the flight.

A functional failure rate of 0.06 failure per 10⁶ hr is used for each cable-pulley control run as a conservative estimate. This is the same rate as used for mechanical elements with zero failure events.

Hydraulic Modules—Removal rates for hydraulic equipment are higher than those for mechanical items; these rates can be determined from airline shop records and used to assess functional failures. Appendix C is a record of power control unit (PCU) shop findings covering a group of five airlines over a 4-year period. Most PCU removals are for internal leakage problems where hydraulic fluid pressure, temperature, moisture content, and other contaminants have caused the moving parts to erode internally. Functional failures will occur in 5% of the PCU removals explained as follows. Normally, an actuator will continue to function adequately with a certain degree of internal leakage and usually the unit is replaced before excessive leakage develops. As part of scheduled maintenance, an operator will conduct a leakage check on each hydraulic system. If the internal leakage rate exceeds certain levels, the high-leakage component or components must be replaced. When low hydraulic power is combined with the presence of a unit with high internal leakage, at a time of high power demand, force may be insufficient to move a control surface the desired amount. This is considered a functional failure. For this analysis, the functional failure rate is 50% of every removal for internal leakage times an estimated probability of 10% of every flight that did not have sufficient power for adequate actuation.

Hydraulic Power—Hydraulic pressure for each of the four systems is supplied normally by power from four engines through four engine-driven pumps. Power is also available from the pneumatic source, engine bleed air, or APU to four air-driven pumps mounted next to each engine-driven pump. Hydraulic pressure can be lost only when both power sources are unavailable.

The distribution of pressure for each hydraulic system is not redundant. A line breakage or component housing fracture will result in hydraulic fluid loss and subsequent pressure loss even though the power source may still be available. This loss results in no power to the actuators and prevents mechanical actuation. With actuators that have dual cylinders served by two hydraulic systems, the fluid loss from one system does not prevent mechanical actuation.

A hydraulic system failure rate used for this study is the hydraulic pressure loss rate. It can be calculated from the number of times fluid has been lost and the number of hours flown for each system. Power source losses are small compared with fluid losses.

Hydraulic system losses for two model 747 operators are detailed in appendix D. Fractures of flight control power units that result in fluid losses are counted in the hydraulic system loss rate, but are not counted again as a power unit failure.

There were 39 system losses for the two operators between February 1975 and April 1976, with an accumulated flight time of 223,857 hr. For each hydraulic system, the loss rate equalled $43.5/10^6$ hr.

Although the individual loss rates will be different for each of the four systems, an average loss rate figure is used. This is done because the CARSRA program is set up more efficiently to handle similar modules having identical failure rates.

Electrical Power—The primary electrical power is provided by four generators powered through constant-speed drives (CSD) from the engines and normally working in parallel to supply four main ac buses. The failure rate for each generator channel is the sum of the component failure rates, as listed in table 4.

Table 4. Electrical Power Component Failure Rates

Component	Failure per 10^6 hr
a.c. elements	
Constant speed drive	333.0
Generator	228.7
Constant speed drive oil cooler	15.5
Frequency load controller	45.1
Generator control unit	236.5
Engine (in-flight shutdowns)	84.8*
	$\lambda=943.6$
d.c. elements	
Essential relay diode	2.4
Transformer rectifier unit	10.2
Isolation relay	15.6
* 212.0 failures per 10^6 hours with 60% restarts	

The probability of losing essential ac bus power during a 1-hr flight (t) equals the probability of losing all four generator channels.

$$\begin{aligned}
 &= (1 - e^{-\lambda t})^4 \\
 &= 0.79 \times 10^{-12}
 \end{aligned}$$

For the flight controls under study, the stabilizer trim system requires the use of a 28V dc power supply to the arming and control switches. The power is converted from the ac bus by transformer-rectifier units (TRU) as shown in the description, section 4.1, figure 29. The essential dc bus can be serviced either through the essential TRU or through the essential dc bus isolation relay.

The probability of losing power to the essential 28V dc bus can be determined by the fault tree shown in figure 34. The failure rates for the dc components are listed in table 4. Figure 34 shows that the probability of losing 28V dc power is 0.253×10^{-10} for a 1-hr flight.

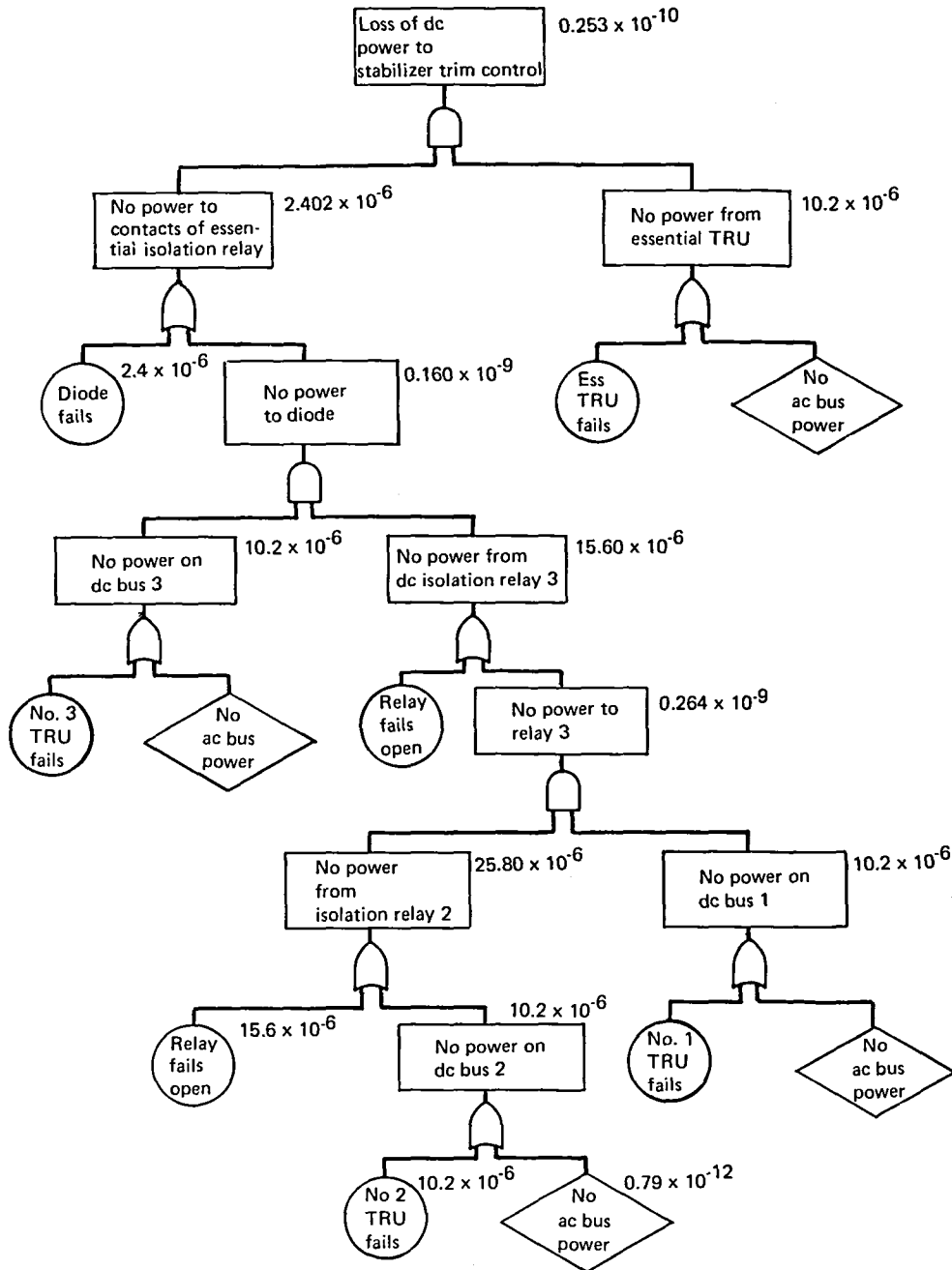

Figure 34. Electrical Power Fault Tree

Pushrod to outboard PCU

No removal reported for this item
Functional failure mode—open/jam
Assume 1/3 failure in 5,300,000 flight-hours
Functional failure rate = 0.06 failure/10⁶ hr

o STABILIZER TRIM

Arm switch and control switch

No removal reported for these items
Functional failure mode—open or closed
From reference 3, MIL-HDBK-217B, page 2.10-1, electrical switches:
Functional failure rate, per switch (λ_p) = $\lambda_b (\pi_E \times \pi_C \times \pi_{CYC})$

$$\lambda_b = 0.01 \text{ failure}/10^6 \text{ hr}$$

π_E (airborne environment)	= 15
π_C (contact form)	= 2
π_{CYC} (cyclic ratio)	= 2
Open/closed failure ratio	= 90/10

$$\lambda_p \text{ (open)} = 0.54 \text{ failure}/10^6 \text{ hr}$$

$$\lambda_p \text{ (closed)} = 0.06 \text{ failure}/10^6 \text{ hr}$$

Limit switch

No removal reported for this item
Functional failure mode—open
From reference 3, MIL-HDBK-217B, page 2.10-1, electrical switches:

$$\text{Functional failure rate } (\lambda_p) = \lambda_b (\pi_E \times \pi_C \times \pi_{CYC})$$

$$\lambda_b = 0.007 \text{ failure}/10^6 \text{ hr}$$

π_E (airborne environment)	= 15
π_C (contact form)	= 2
π_{CYC} (cyclic ratio)	= 0.10 (limited operation)
λ_p (open)	= 0.02 failure/10 ⁶ hr

Relay

No removal reported for this item
Functional failure mode—loss of function
From reference 3, MIL-HDBK-217B, table 3-10, relays:
Functional failure rate (inhabited, airborne) = 1.3 failures/10⁶ hr

Arm lever and control lever

No removal reported for these items
Functional failure mode—loss of function
Assume 1/3 failure in 5,300,000 flight-hours, each lever
Functional failure rate = 0.06 failure/10⁶ hr, each lever

Hydraulic motor

Removal rate = 20.4 removals/10⁶ unit-hours
Percent justified removals = 100%
Functional failure mode—loss of function
Percent functional failures = 50% assumed
Functional failure rate = 10.2 failures/10⁶ hr

Primary brake

No removal reported for this item
Functional failure mode—loss of function or jam
Assume 1/3 failure in 5,300,000 flight-hours
Functional failure rate = 0.06 failure/10⁶ hr

Hydraulic brake

Removal rate = 1.7 removals/10⁶ unit-hours
Percent justified removals = 100%
Functional failure mode—loss of function or jam
Percent functional failures = 100%
Functional failure rate = 1.7 failures/10⁶ hr

Jackscrew and nut

No removal reported for this unit
Functional failure modes—jackscrew jam or disconnect
 —ball nut disconnect
 —secondary nut disconnect
Assume 1/3 failure for each nut in 5,300,000 flight-hours
Ball nut functional failure rate = 0.06 failure/10⁶ hr
Secondary nut functional failure rate = 0.06 failure/10⁶ hr
Jackscrew is a dual load path device with a separate inner shaft
Assume 1/3 failure for each load path in 5,300,000 flight-hours
Jackscrew functional failure rate = 0.06 failure/10⁶ hr
Inner shaft functional failure rate = 0.06 failure/10⁶ hr

Shutoff valve

Removal rate = 6.5 removals/10⁶ unit-hours
Percent justified removals = 100%
Functional failure mode—fail closed
Percent functional failures = 50%
Functional failure rate = 3.2 failures/10⁶ hr

Gear drive

Removal rate = 0.6 removal/10⁶ unit-hours
Percent justified removals = 100%
Functional failure mode—differential jam or disconnect
Percent functional failures, each differential = 50%
Functional failure rate, each differential = 0.30 failure/10⁶ hr

Control module

Removal rate = 28.7 removals/10⁶ unit-hours
Percent justified removals = 100%
Functional failure mode—loss of function; high internal leakage
From appendix C, workshop findings for PCU's:
Functional failures
 High internal leakage = 27/55 x 5%
 Mechanical-centering piston jammed = 1/55
 Diaphragm defective = 2/55
 Electrical, shutoff valve defective = 4/55
Nonfunctional failures = 21/55
Functional failure rates
 Hydraulic (high internal leakage) = 0.70 failure/10⁶ hr
 Mechanical = 1.6 failures/10⁶ hr
 Electrical = 2.1 failures/10⁶ hr

o LATERAL CONTROL

Control wheel

Removal rate = 0 removals/10⁶ unit-hours
Functional failure mode--open/jam
Functional failure rate = 0 failures/10⁶ hr

Aileron programmer

Removal rate = 0.4 removal/10⁶ unit-hours
Percent justified removals = 100%
Functional failure mode—open/jam
Percent functional failures = 100%
Functional failure rate = 0.4 failure/10⁶ hr

Central control actuator (CCA)

Removal rate = 30.0 removals/10⁶ unit-hours
Percent justified removals = 61%
Functional failure mode—loss of function, high internal leakage
From appendix C, workshop findings for PCU's:
Functional failures—high internal leakage = 18/45 x 5%
 —other = 0/45
Functional failure rate = 0.4 failure/10⁶ hr

Load limiter

Removal rate = 0 removals/10⁶ unit-hours
Functional failure mode—open/jam
Functional failure rate = 0 failures/10⁶ hr

Spoiler differential (mixer)

Removal rate = 0 removals/10⁶ unit-hours
Functional failure mode—open/jam
Functional failure rate = 0 failures/10⁶ hr

Inboard aileron power control unit (PCU)

Removal rate = 37.1 removals/10⁶ unit-hours
Percent justified removals = 100%
Functional failure mode—loss of function, high internal leakage

From appendix C, workshop findings for PCU's:
Functional failures—high internal leakage = 60/91 x 5%
 —other = 0/91
Functional failure rate = 1.2 failures/10⁶ hr

Outboard aileron power control unit (PCU)
Removal rate = 22.3 removals/10⁶ unit-hours
Percent justified removals = 100%
Functional failure mode—loss of function, high internal leakage
From appendix C, workshop findings for PCU's:
Functional failures—high internal leakage = 33/50 x 5%
 —other = 0/50
Functional failure rate = 0.7 failure/10⁶ hr

Outboard aileron lockout actuator
Removal rate = 8.0 removals/10⁶ unit-hours
Percent justified removals = 100%
Functional failure mode—loss of function
Percent functional failures = 100%
Functional failure rate = 8.0 failures/10⁶ hr

Outboard aileron lockout gearbox
Removal rate = 1.7 removals/10⁶ unit-hours
Percent justified removals = 100%
Functional failure mode—open/jam
Percent functional failures = 100%
Functional failure rate = 1.7 failures/10⁶ hr

Inboard spoiler power control unit (PCU)
Removal rate = 15.3 removals/10⁶ unit-hours
Percent justified removals = 80%
Functional failure mode—loss of function, high internal leakage
From appendix C, workshop findings for PCU's:
Functional Failures—high internal leakage = 15/31 x 5%
 —other = 0/31
Functional failure rate = 0.3 failure/10⁶ hr

Outboard spoiler power control unit (PCU)
Removal rate = 14.0 removals/10⁶ unit-hours
Percent justified removals = 92%
Functional failure mode—loss of function, high internal leakage
From appendix C, workshop findings for PCU's:
Functional failures—high internal leakage = 78/118 x 5%
 —other = 0/118
Functional failure rate = 0.4 failure/10⁶ hr

o RUDDER CONTROL

Feel, trim, and centering mechanism
Removal rate = 0 removals/10⁶ unit-hours
Functional failure mode—open/jam
Functional failure rate = 0 failures/10⁶ hr

Rudder pedal

No removal reported for this item
Functional failure mode—open/jam
Assume 1/3 failure in 5,300,000 flight-hours
Functional failure rate = 0.06 failure/10⁶ hr

Forward quadrant

No removal reported for this item
Functional failure mode—open/jam
Assume 1/3 failure in 5,300,000 flight-hours
Functional failure rate = 0.06 failure/10⁶ hr

Aft quadrant

Removal rate = 1.7 removals/10⁶ unit-hours
Percent justified removals = 100%
Functional failure mode—open/jam
Percent functional failures = 100%
Functional failure rate = 1.7 failures/10⁶ hr

Rudder trim actuator

Removal rate = 3.6 removals/10⁶ unit-hours
Percent justified removals = 100%
Functional failure mode—open/jam
Percent functional failures = 100%
Functional failure rate = 3.6 failures/10⁶ hr

Rudder power control unit (PCU)

Removal rate = 57.7 removals/10⁶ unit-hours
Percent justified removals = 94%
Functional failure mode—loss of function, high internal leakage
From appendix C, workshop findings for PCU's:
Functional failures—high internal leakage = 62/122 x 5%
 —other = 0/122
Functional failure rate = 1.6 failures/10⁶ hr

Linkage to PCU

No removal reported for this unit
Functional failure mode—open/jam
Assume 1/3 failure in 5,300,000 flight-hours
Functional failure rate = 0.06 failure/10⁶ hr

o SPEED BRAKES

Control lever

Removal rate = 3.3 removals/10⁶ unit-hours
Percent justified removals = 100%
Functional failure mode—open/jam
Percent functional failures = 0%
Functional failure rate = 0 failures/10⁶ hr

Table 5. Functional Failure Rate Summary

Component	Functional failure rate (failures per 10 ⁶ hr)
Elevator	
Control column	0.0
Forward quadrant	0.06
Rear quadrant	0.0
Rear linkage (each load path)	0.06
Inboard elevator power control unit	1.6
Outboard elevator power control unit	0.5
Pushrod to outboard power control unit	0.06
Stabilizer trim	
Arm switch (open)	0.54
Arm switch (closed)	0.06
Control switch (open)	0.54
Control switch (closed)	0.06
Limit switch (open)	0.02
Relay	1.30
Arm lever	0.06
Control lever	0.06
Hydraulic motor	10.2
Primary brake	0.06
Hydraulic brake	1.7
Ball nut	0.06
Secondary nut	0.06
Jackscrew (each load path)	0.06
Shutoff valve	3.2
Gear drive (each differential)	0.3
Control module (hydraulic)	0.7
Control module (mechanical)	1.6
Control module (electrical)	2.1
Lateral control	
Control wheel	0.0
Aileron programmer	0.4
Central control actuator	0.4
Load limiter	0.0
Spoiler differential (mixer)	0.0
Inboard aileron power control unit	1.2
Outboard aileron power control unit	0.7
Outboard aileron lockout actuator	8.0
Outboard aileron lockout gearbox	1.7
Inboard spoiler power control unit	0.3
Outboard spoiler power control unit	0.4
Rudder control	
Feel, trim, and centering mechanism	0.0
Rudder pedal	0.06
Forward quadrant	0.06
Aft quadrant	1.7
Rudder trim actuator	3.6
Rudder power control unit	1.6
Linkage to power control unit	0.06
Speed brakes	
Control lever	0.0
Sequence mechanism	0.0
Ground spoiler control valve	2.4
Ground spoiler actuator	0.75

4.2.4 Control Function Analysis

This section constructs models for the analysis by integrating the operating characteristics (sec. 4.1), the failure definitions (sec. 4.2.2), and the component reliability (sec. 4.2.3). Figure 35 shows the modeling process. As discussed in the analysis methodology (sec. 4.2.1), the CARSRA program is then used to compute reliability for each control function; the results are included in this section.

The first step consists of identifying the stages in the reliability block diagram developed in the system description (sec. 4.1). For an example, consider the modeling of the elevator control function in section 4.2.4.1. The numbers on the top of each block of the stage identification (fig. 37) are the module functional failure rates. In the next step, the identified stages are assembled as a dependency tree (fig. 38). Dependencies between the various stages are indicated by the lines connecting the stages, while the direction of a dependency is indicated by an arrowhead. The dependency tree is used to establish the dependency array by which the system dependency structure is specified for CARSRA.

Markov models, one model for each stage, also are constructed from the stage identification diagram (fig. 39).

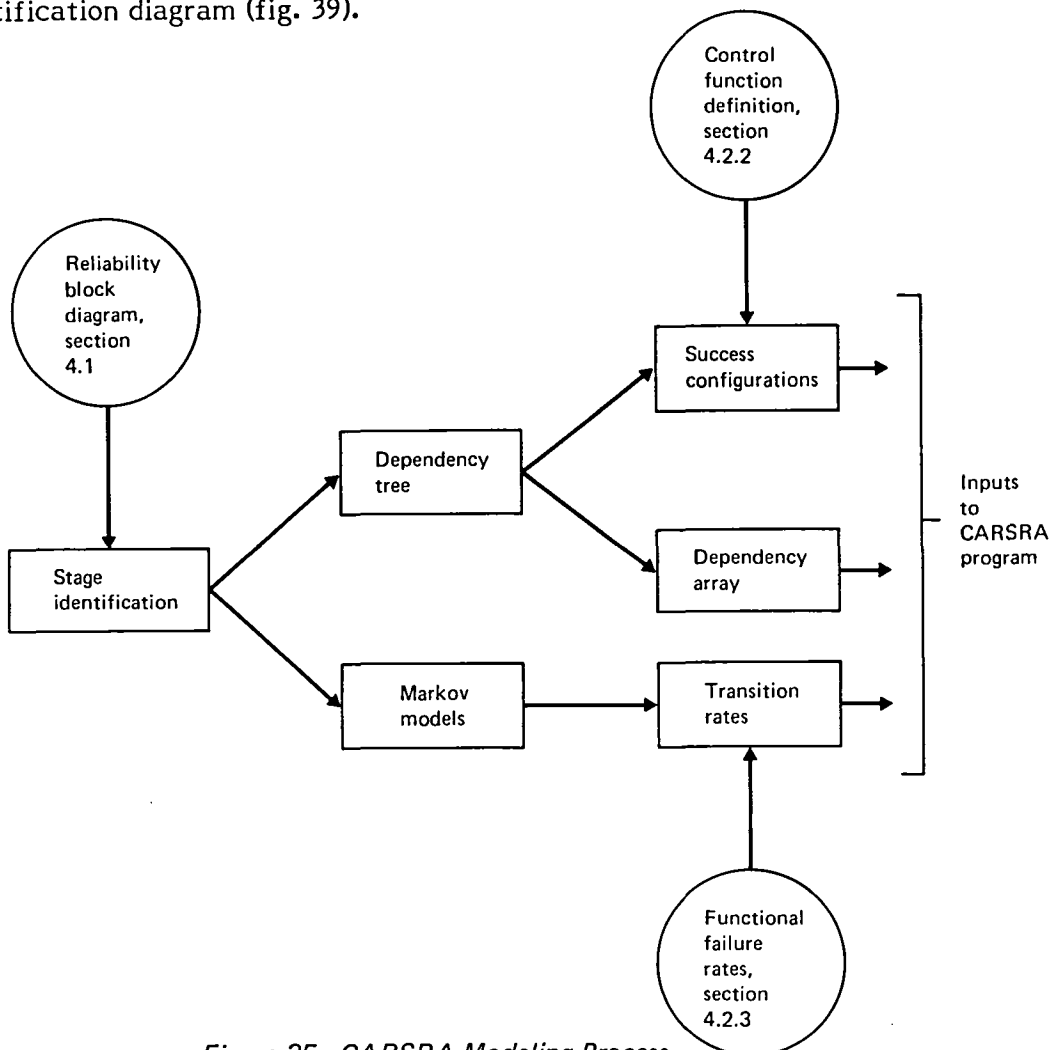

Figure 35. CARSRA Modeling Process

Although stages, in general, are assembled from modules with identical failure rates, a group of modules with different failure rates has been modeled in the study. This was done because the limits of the CARSRA program may be exceeded if too many stages are modeled. An example of this approach is illustrated in figure 36. The Markov model shows that stage failure can occur either by a single failure from state 1 to state 3 (λ_B) or the stage will tolerate a first failure to state 2. The transition rate from state 1 to state 2 (λ_{1-2}) has a value of $2\lambda_A$, which means that two modules (A_1 and A_2) are operating, and any one can fail first. The transition from state 2 to state 3 occurs when the remaining module A fails. This Markov model, seen by itself, should not be treated as a two-module system with coverage rates as described in section 4.3.1.

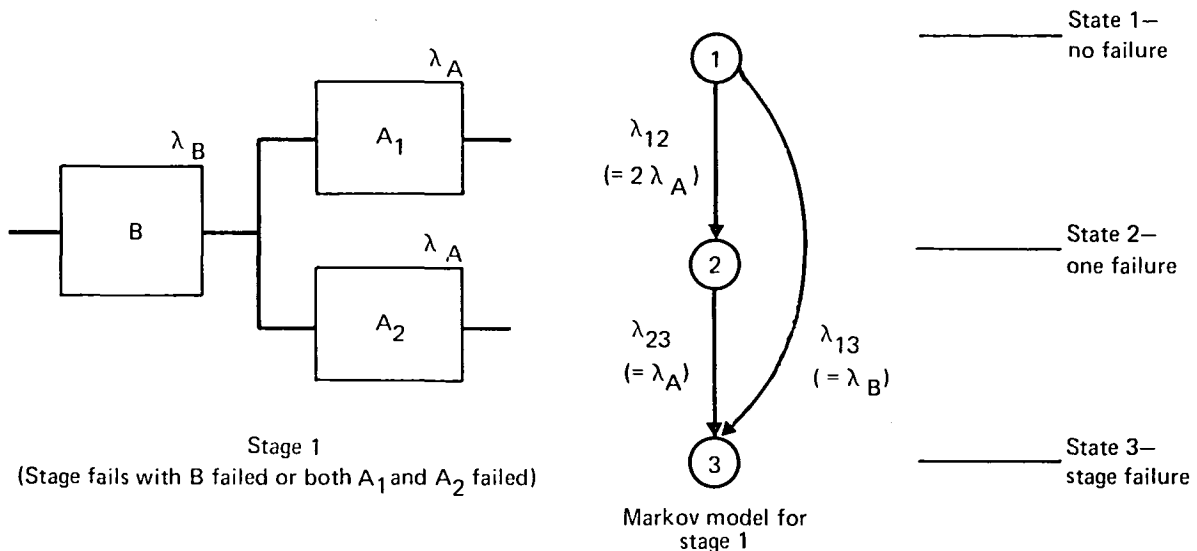

Figure 36. Markov Model With Different Modules

The transition rates, $\lambda_{2-3} (= \lambda_A)$ and $\lambda_{1-3} (= \lambda_B)$, are the functional failure rates of modules A and B, respectively. All the functional failure rates for the control functions have been developed in section 4.2.3.

Success configurations are the last step required to complete the input file for the CARSRA program. These configurations state which stages may fail without causing system functional failure. All combinations, including single stage failures, dual stage failures, etc., are required (this information was determined in the system definition, sec. 4.2.2).

Failure probability results from the CARSRA program indicate the probability of losing a control function during specified exposure times. The exposure times have been identified as flight times ranging from 1 to 10 hr in 1-hr increments. Actual model 747 operations are conducted throughout this flight length range. Each control function is considered to be operational at the beginning of flight time.

The CARSRA program also computes functional readiness. For this study, a functional readiness criterion corresponding to no module failed was established for the elevator, stabilizer trim, lateral, and rudder control functions at successive 2-hr increments of a flight. The results show the probability of not having a fully operational control function at the given stage of the flight. For the speed brakes,

which may be required at a certain time during a flight, a functional readiness criterion, corresponding to a combination of failed modules, was established. The combination is the same as that established in the control function definition for speed brakes (sec. 4.2.2).

The use of the CARSRA program to compute the reliability of the 747 PFCS has necessitated a slightly different approach in modeling the system. No attempt has been made to change the program itself. To verify the CARSRA results, a check is made against an existing analysis technique using a computer program for assessing the reliability of redundant systems. The program, computerized reliability analysis method (CRAM), uses system-related inputs (time period, component failure rates, and system success paths). It calculates the resultant system reliability.

The assumptions for CRAM are as follows.

1. Exponential distribution applies (constant failure rate). Reliability of component i is r_i .
$$R_i = e^{-r_i t}$$
where r_i is the failure rate for component i , and t is the time period.
2. Each component is independent of all other components.
3. Each component has two mutually exclusive states: failed and operational (not failed).
4. All components are operational at the beginning of the time period.
5. Component failures are not repaired within the time period considered.

CRAM uses a modified event-space method to calculate system reliability.

For a system with n components, there are 2^n logical combinations of component success or failure that can occur. All events in this "event space" are mutually exclusive. To determine the system reliability, only the identity of the system success events and the sum of the occurrence probabilities of each successful event must be determined.

By systematically developing the events of the event space with respect to the number of failed components, it is possible to reduce the number of events to be checked to more reasonable levels and yet maintain satisfactory results. CRAM develops the events by zero failures, one failure, two failures, . . . k failures ($k = 8$ maximum). If the component unreliabilities are fairly small, the sum of the occurrence probabilities of the successful events, involving $K + 1$ failures or more, will be so small that the accuracy of the final answer will not be adversely affected.

The control function failure-probability results were verified by modeling the control function for the CRAM program. This consisted of using the dependency tree diagram as a success path diagram in conjunction with the success configuration. CRAM computes system reliability. For this analysis, the system reliability was calculated for a flight time of 1 hr.

The elevator and rudder control failure probabilities have been checked using CRAM. The results are included with the CARSRA results in sections 4.2.4.1 and 4.2.4.4.

4.2.4.1 Elevator Control Reliability

On the basis of the stage identification (fig. 37), dependency tree (fig. 38), and Markov models (fig. 39), the stage failures are listed in table 6, dependencies are listed in table 7, and success configurations are listed in table 8.

The failure probabilities of the elevator control function using CARSRA are shown in table 9. The functional readiness for no module failed for the elevator control function is shown in table 10.

The control function reliability for a 1-hr flight can be calculated, using CRAM, from the elevator control success path diagram (fig. 40) developed from the dependency tree diagram (fig. 38) and the success configurations (table 8). The failure probability is equal to 1 minus system reliability.

Failure probability for a 1-hr flight = 0.189×10^{-12} (result from CRAM)

This result compares with the CARSRA result of 0.357×10^{-12} per 1-hr flight. The difference results from the modeling of the hydraulic supply, stage 2. For CARSRA, three or more failed hydraulic supply systems will cause stage failure, thus control

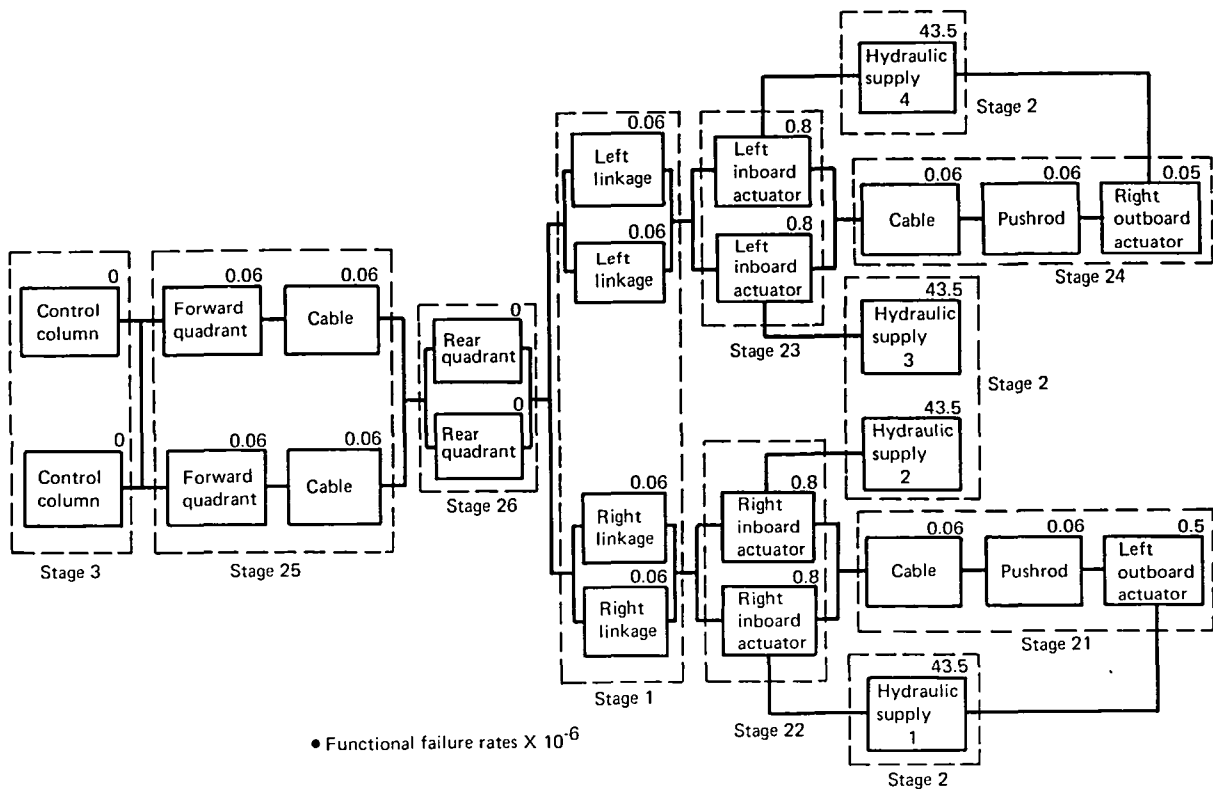

Figure 37. Elevator Control Stage Identification

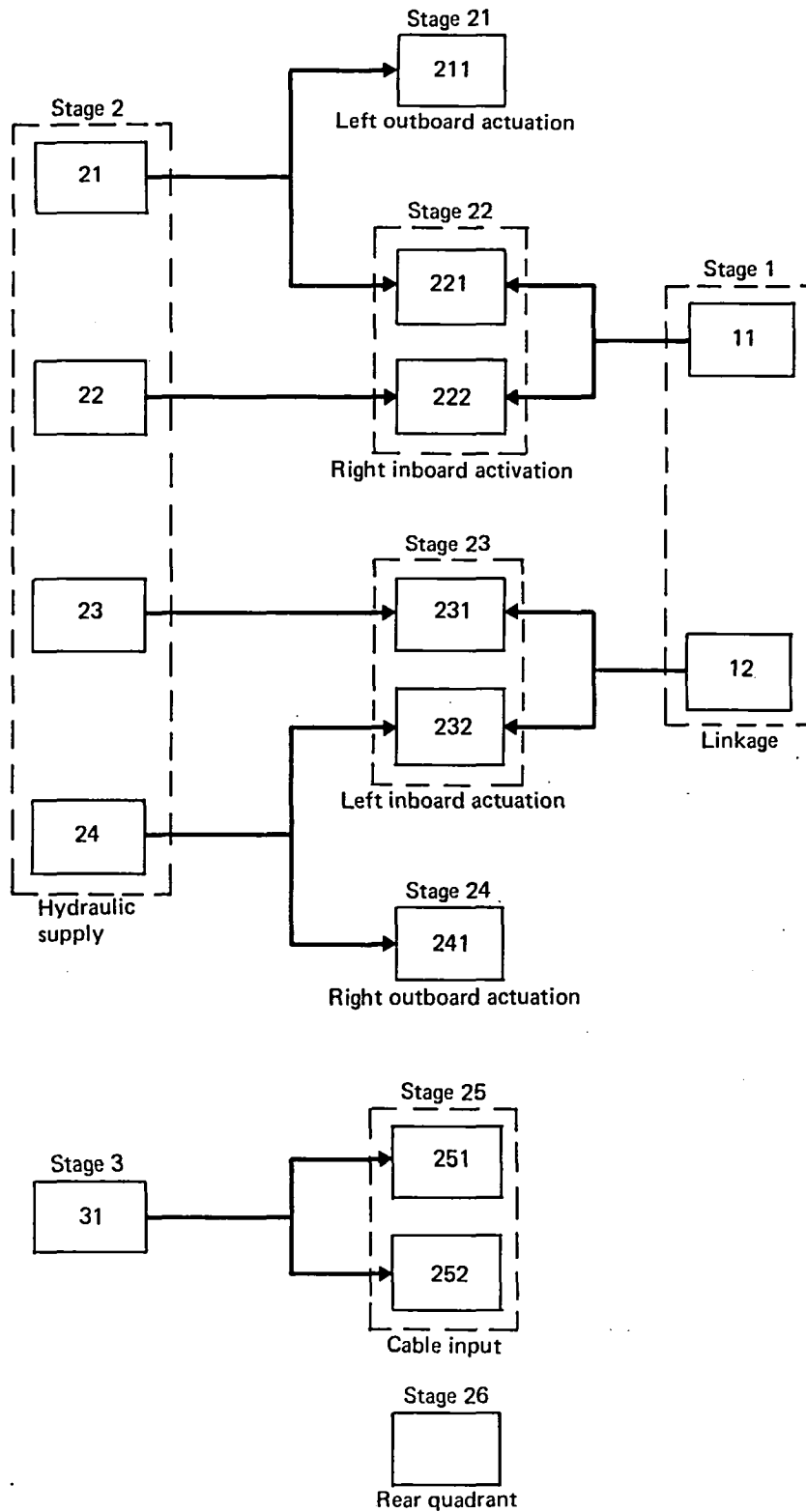

Figure 38. Elevator Control Dependency Tree

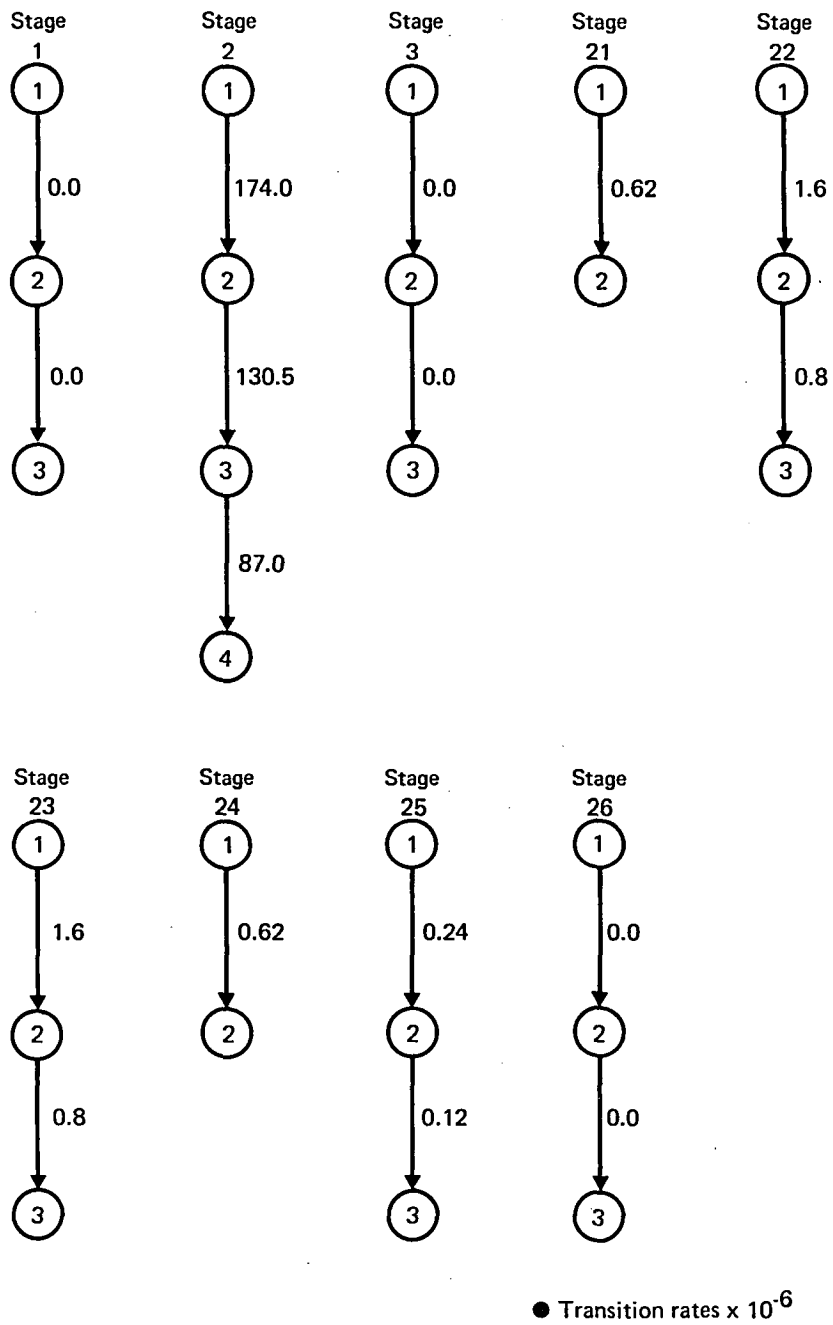

Figure 39. Elevator Control Markov Models

Table 6. Elevator Control Stage Failures

Stage No.	Stage description	Stage failure
Dependent stages		
1	Linkage to left and right inboard elevators	Stage fails with fourth load path failure of the two linkages
2	Hydraulic supply	Stage fails with third hydraulic supply system failure
3	Control column	Stage fails with second control column failure
Nondependent stages		
21	Left outboard elevator actuation	Stage fails with cable, pushrod, or actuator failure
22	Right inboard elevator power control unit	Stage fails with second actuator failure
23	Left inboard elevator power control unit	Stage fails with second actuator failure
24	Right outboard elevator actuation	Stage fails with cable, pushrod, or actuator failure
25	Cable and forward quadrant	Stage fails with second cable/quadrant failure
26	Aft quadrant	Stage fails with second load path of aft quadrant failure

Table 7. Elevator Control Module Dependencies

Dependent modules	Nondependent modules
11 →	221, 222
12 →	231, 232
21 →	211, 221
22 →	222
23 →	231
24 →	232, 241
31 →	251, 252

Table 8. Elevator Control Stage Success Configurations

Failures	Stage failure combinations that do not cause system failure
Single	Stage 21, or Stage 22, or Stage 23, or Stage 24
Dual	Stages 21 and 22, or Stages 21 and 24, or Stages 23 and 24

Table 9. Elevator Control Failure Probabilities

Flight length (hours)	Failure probability
1.0	0.357×10^{-12}
2.0	0.276×10^{-11}
3.0	0.928×10^{-11}
4.0	0.218×10^{-10}
5.0	0.425×10^{-10}
6.0	0.734×10^{-10}
7.0	0.116×10^{-9}
8.0	0.174×10^{-9}
9.0	0.247×10^{-9}
10.0	0.339×10^{-9}

Table 10. Elevator Control Functional Readiness (No Modules Failed)

Time from start of flight (hours)	Functional readiness at time of flight
2.0	0.999643
4.0	0.999286
6.0	0.998928
8.0	0.998572
10.0	0.998215

SYSTEM CONSIDERED -

ELEVATOR CONTROL

SUCCESS PATHS

```

1 3 7 8
1 3 7 4 9
1 3 8 5 10
1 3 8 6 11
1 4 9 5 10
1 4 9 6 11
1 5 10 6 12
1 6 11 12
2 3 7 8
2 3 7 4 9
2 3 8 5 10
2 3 8 6 11
2 4 9 5 10
2 4 9 6 11
2 5 10 6 12
2 6 11 12
    
```

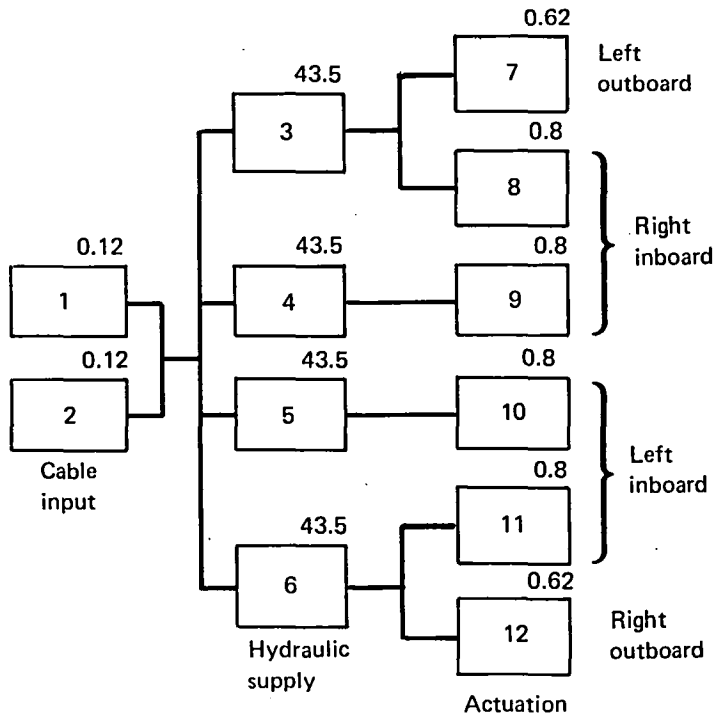

TIME = 0.100000000000000D+01

COMP	FAILURE RATE	RELIABILITY
1	0.120000000000000D-06	0.999999880000007D+00
2	0.120000000000000D-06	0.999999880000007D+00
3	0.435000000000000D-04	0.999956500946111D+00
4	0.435000000000000D-04	0.999956500946111D+00
5	0.435000000000000D-04	0.999956500946111D+00
6	0.435000000000000D-04	0.999956500946111D+00
7	0.620000000000000D-06	0.999999380000192D+00
8	0.800000000000000D-06	0.999999200000320D+00
9	0.800000000000000D-06	0.999999200000320D+00
10	0.800000000000000D-06	0.999999200000320D+00
11	0.800000000000000D-06	0.999999200000320D+00
12	0.620000000000000D-06	0.999999380000192D+00

FAILURES	SYSTEM RELIABILITY	SUCCESS EVENTS	TOTAL EVENTS
0	0.999821335962320D+00	1	1
1	0.999999987824187D+00	13	13
2	0.999999999999601D+00	78	79
3	0.999999999999811D+00	272	299
4	0.999999999999811D+00	602	794

SYSTEM RELIABILITY = 0.999999999999811D+00

Figure 40. Elevator Control Success Path Model

function failure. CRAM computes reliability by specifying exact success configurations. The elevator control system has four success paths where three hydraulic supply systems can fail without control function failure. These success paths (1-3-7-8, 1-6-11-12, 2-3-7-8, and 2-6-11-12) correspond to successful operation of one inboard elevator and the opposite outboard elevator when only one hydraulic supply system (number 1 or 4) is available. In all other success configurations, at least two hydraulic systems are needed to maintain the control function.

To model these success configurations, some with two hydraulic systems failed and others with three hydraulic systems failed, for CARSRA, each hydraulic supply system must be in a separate stage. This approach, however, does not make use of the features for which CARSRA was designed: the ability to group like modules in a single stage.

4.2.4.2 Stabilizer Trim Reliability

On the basis of the stage identification (fig. 41), dependency tree (fig. 42), and Markov models (fig. 43), the stage failures are listed in table 11, dependencies are listed in table 12, and the success configurations are listed in table 13.

The failure probabilities of the stabilizer trim function using CARSRA are shown in table 14. The functional readiness for no module failed for the stabilizer trim function is shown in table 15.

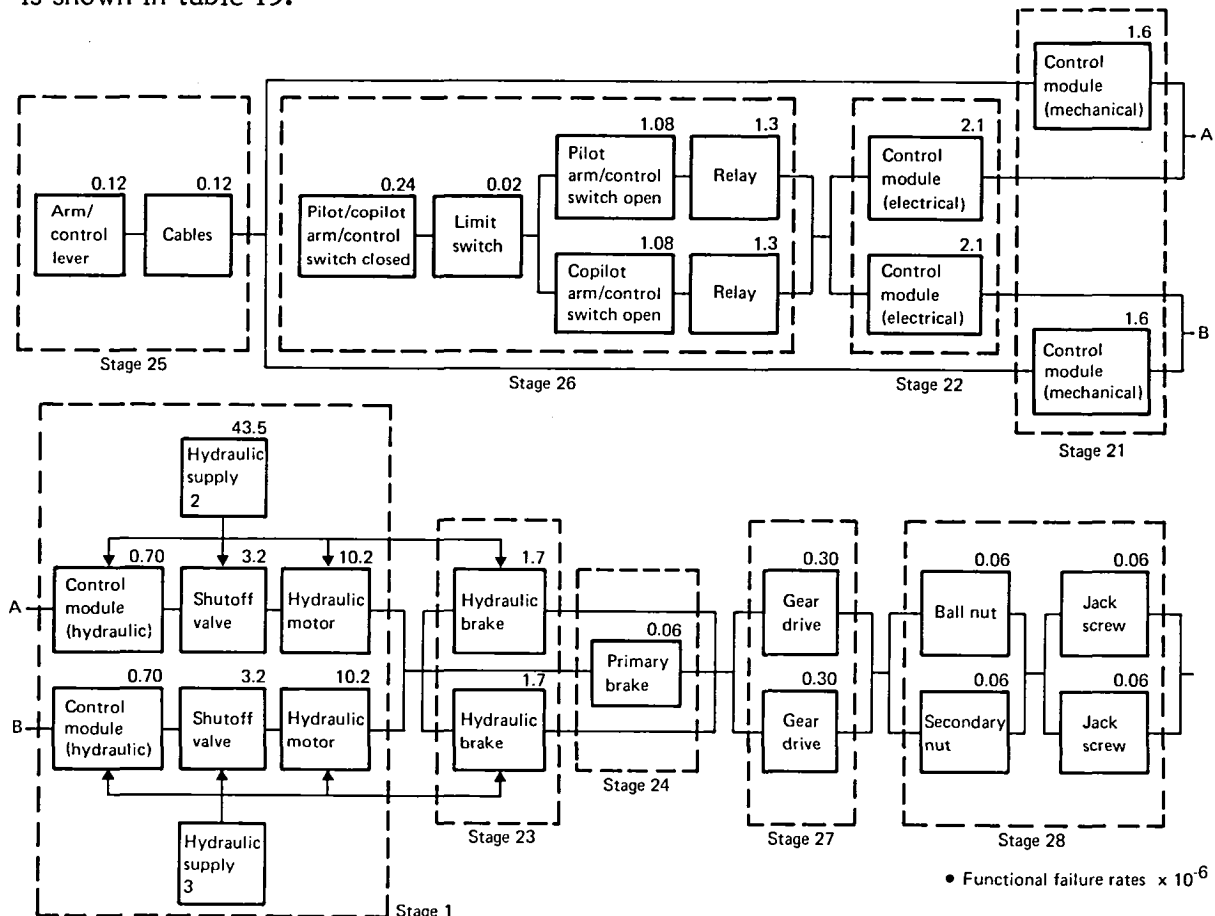

Figure 41. Stabilizer Trim Stage Identification

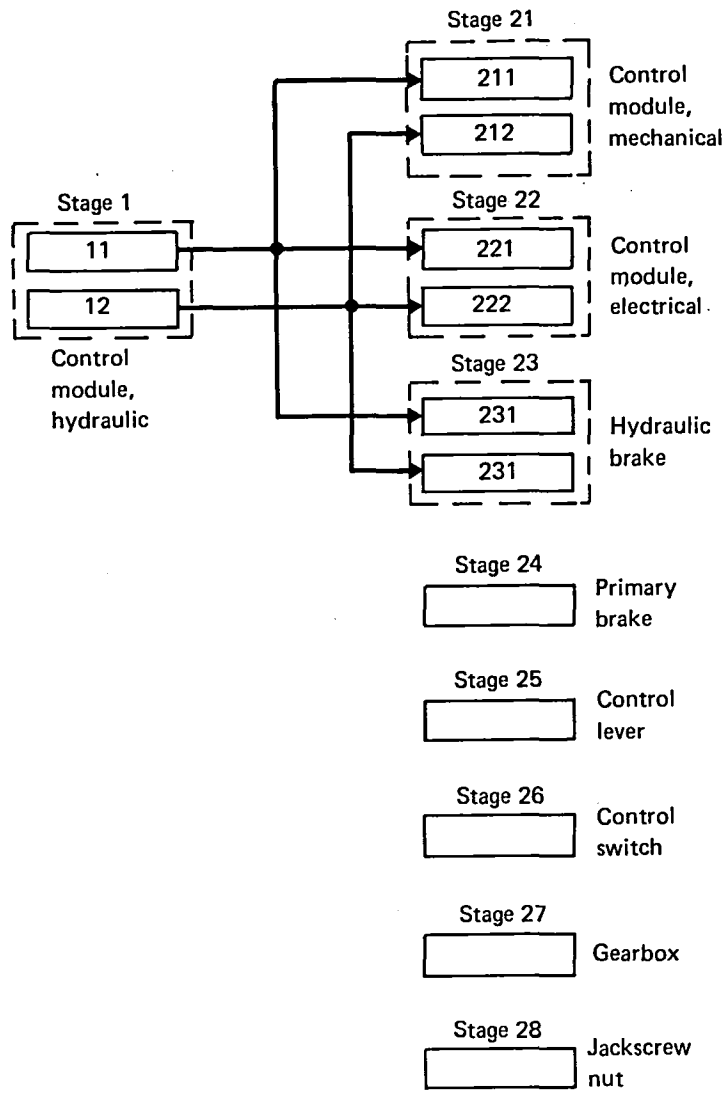

Figure 42. Stabilizer Trim Dependency Tree

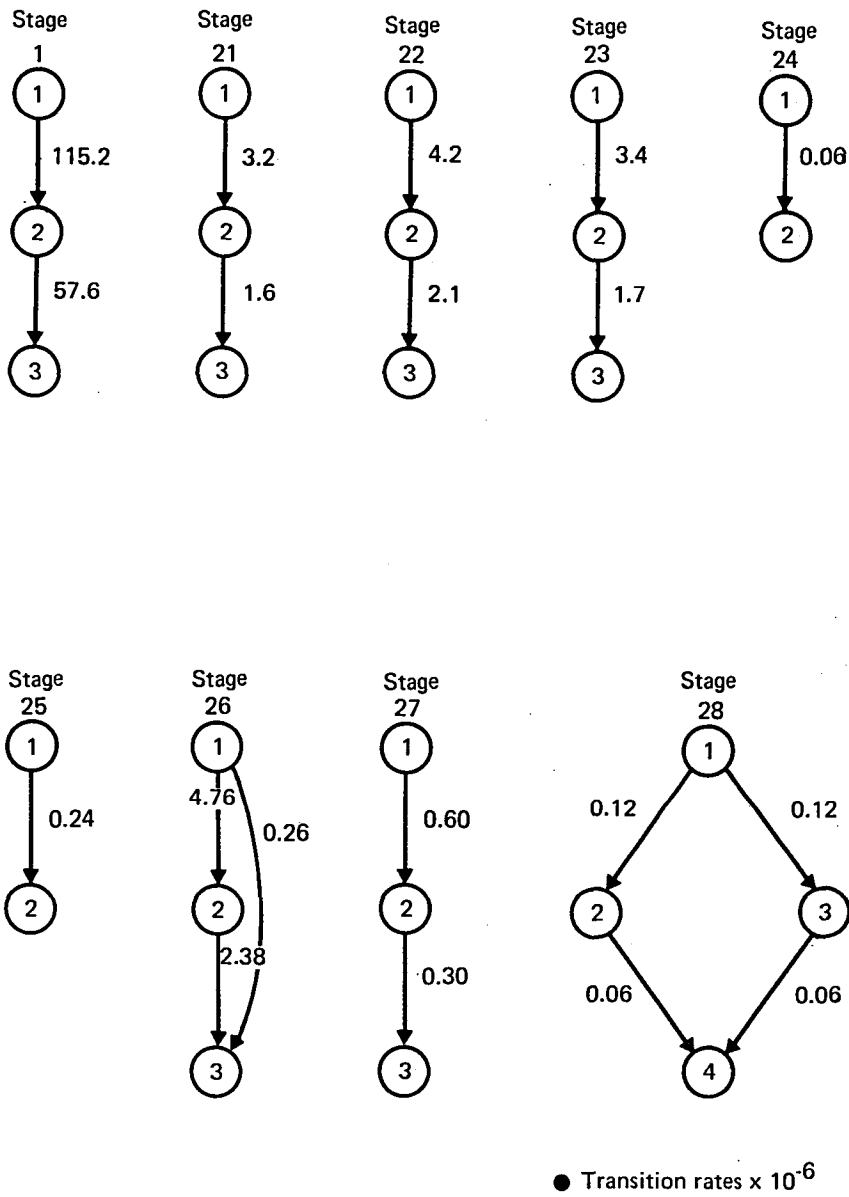

Figure 43. Stabilizer Trim Markov Models

Table 11. Stabilizer Trim Stage Failure

Stage no.	Stage description	Stage failure
Dependent stages 1	Control module (hydraulic)	Stage fails with second failure of control module (hydraulic), shutoff valve, motor, or hydraulic supply
Nondependent stages 21	Control module (mechanical)	Stage fails with second control module (mechanical) failure
22	Control module (electrical)	Stage fails with second control module (electrical) failure
23	Hydraulic brake	Stage fails with second brake failure
24	Primary brake	Stage fails with brake failure
25	Mechanical control	Stage fails with any lever or cable failure
26	Electrical control	Stage fails with one arm/control switch failure (closed), or limit switch failure, or both arm/control switch failures (open), or both relay failures
27	Gearbox	Stage fails with second gear drive failure
28	Jackscrew/ball nut	Stage fails with either second nut failure or second jackscrew failure

Table 12. Stabilizer Trim Module Dependencies

Dependent modules	Nondependent modules
11 →	211, 221, 231
12 →	212, 222, 232

Table 13. Stabilizer Trim Stage Success Configurations

Failures	Stage failure combinations that do not cause system failure
Single	Stage 21, or Stage 22, or Stage 23, or Stage 24, or Stage 25, or Stage 26
Triple	Stages 21, 23, and 25, or Stages 21, 24, and 25, or Stages 22, 23, and 26, or Stages 22, 24, and 26

Table 14. Stabilizer Trim Failure Probabilities

Flight length (hours)	Failure probability
1.0	0.332×10^{-8}
2.0	0.133×10^{-7}
3.0	0.299×10^{-7}
4.0	0.531×10^{-7}
5.0	0.829×10^{-7}
6.0	0.119×10^{-6}
7.0	0.163×10^{-6}
8.0	0.212×10^{-6}
9.0	0.269×10^{-6}
10.0	0.332×10^{-6}

Table 15. Stabilizer Trim Functional Readiness (No Modules Failed)

Time from start of flight (hours)	Functional readiness at time of flight
2.0	0.999736
4.0	0.999472
6.0	0.999207
8.0	0.998943
10.0	0.998679

4.2.4.3 Lateral Control Reliability

On the basis of the stage identification (fig. 44), dependency tree (fig. 45), and Markov models (fig. 46), the stage failures are listed in table 16, the dependencies are listed in table 17, and success configurations are listed in table 18.

Table 16. Lateral Control Stage Failures

Stage no.	Stage description	Stage failure
Dependent stages 1	Hydraulic supply	Stage fails with third hydraulic supply failure
Nondependent stages 21	Outboard spoiler power control units, cable and right hand mixer	Stage fails with second spoiler pair or cable, or spoiler mixer failure
22	Right hand inboard aileron power control unit, cable, and programmer	Stage fails with second actuator failure or cable/programmer failure
23	Left hand inboard aileron power control unit, cable, and programmer	Stage fails with second actuator failure or cable/programmer failure
24	Inboard spoiler power control unit, cable, and left hand mixer	Stage fails with third spoiler actuator pair failure or cable/left hand mixer failure
25	Central control actuator load limiters	Stage fails with second CCA failure (fourth cylinder). Load limiters are not modeled due to zero failure rate
26	Input control cables	Stage fails with second cable failure
27	Pilot and copilot control wheels	Stage fails with second control wheel failure

Table 17. Lateral Control Module Dependencies

Dependent modules	Nondependent modules
11 →	221, 251
12 →	211, 231, 241, 252
13 →	212, 222, 242, 253
14 →	232, 243, 254

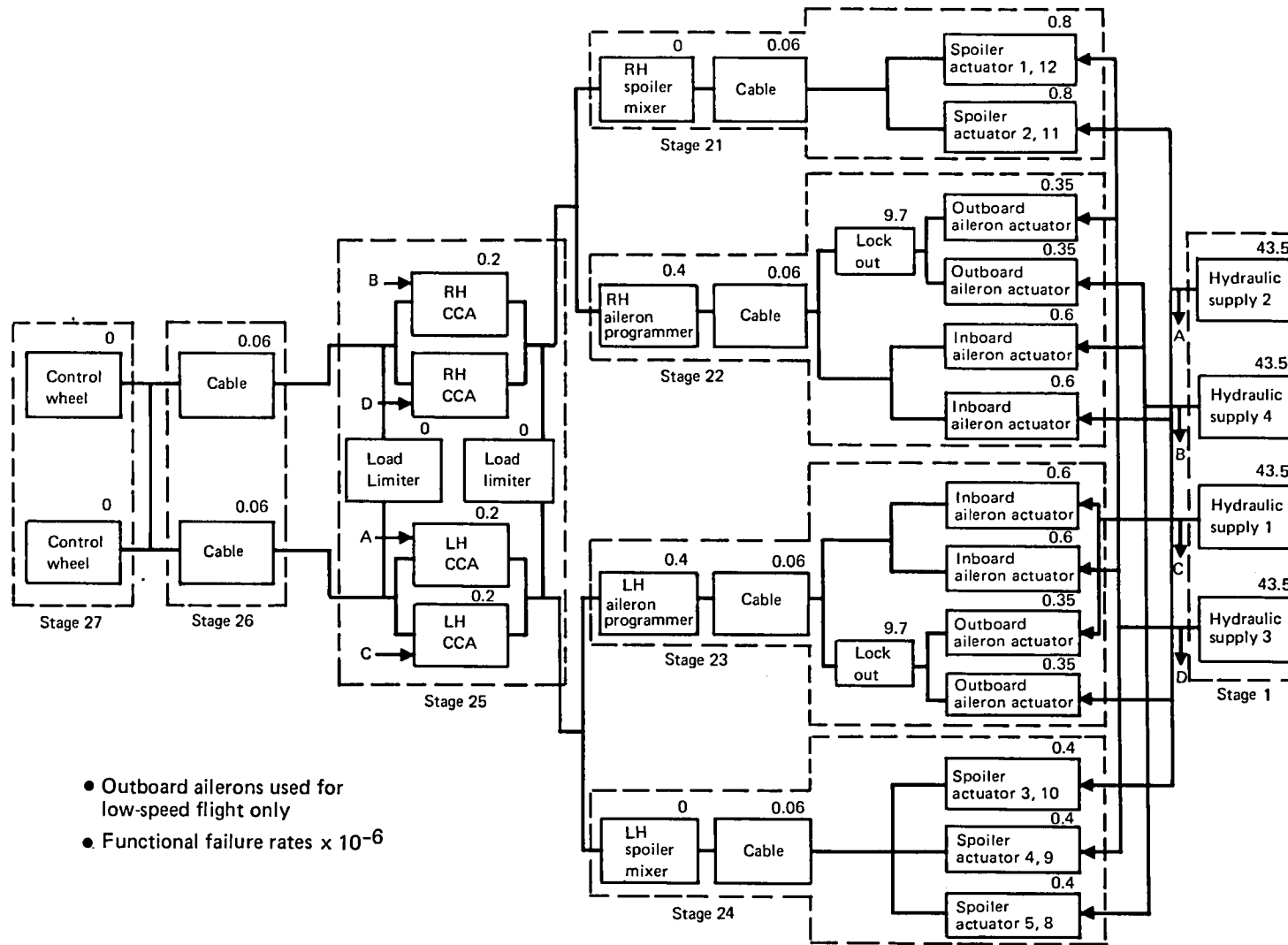

Figure 44. Lateral Control Stage Identification

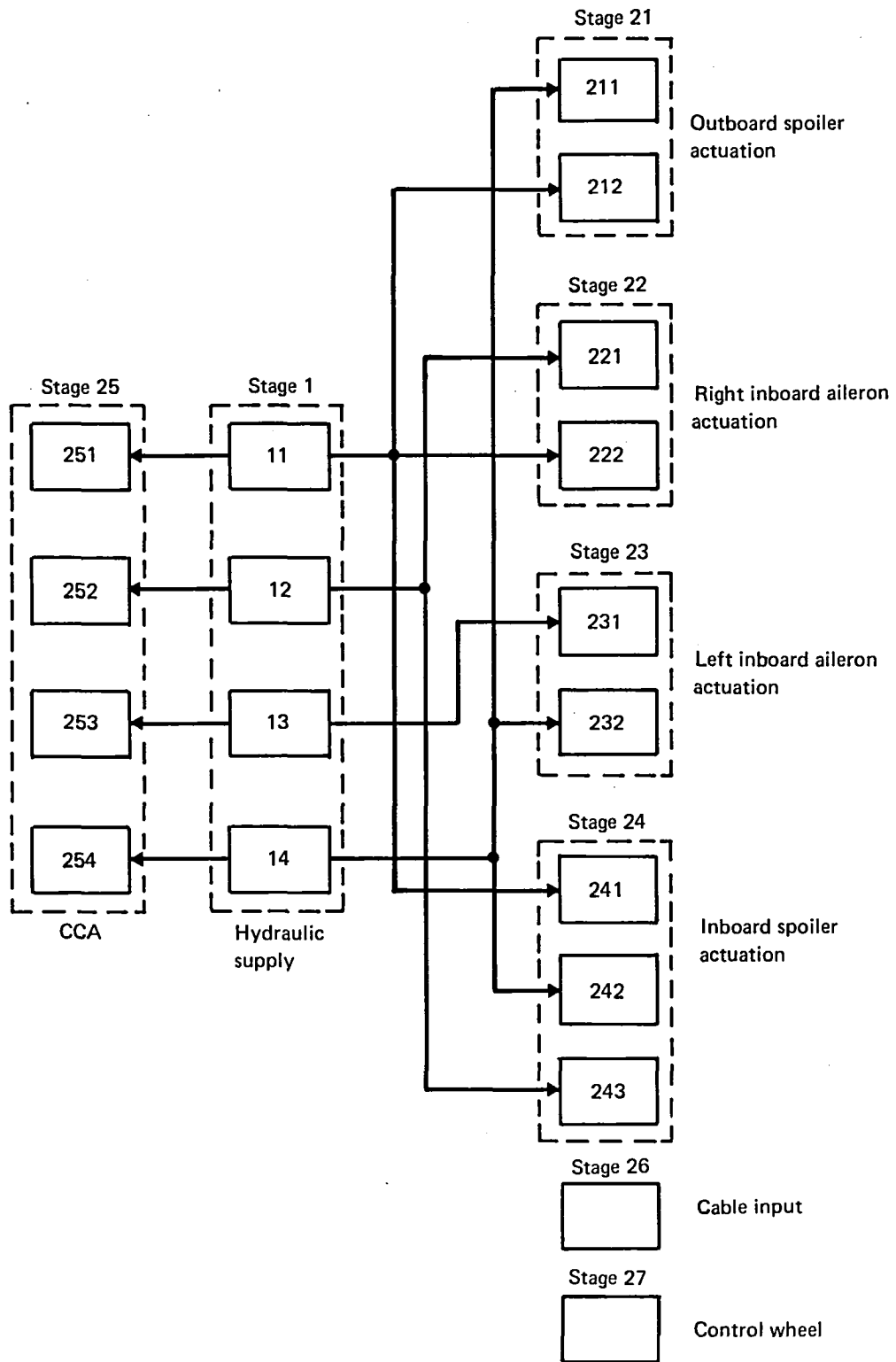

Figure 45. Lateral Control Dependency Tree

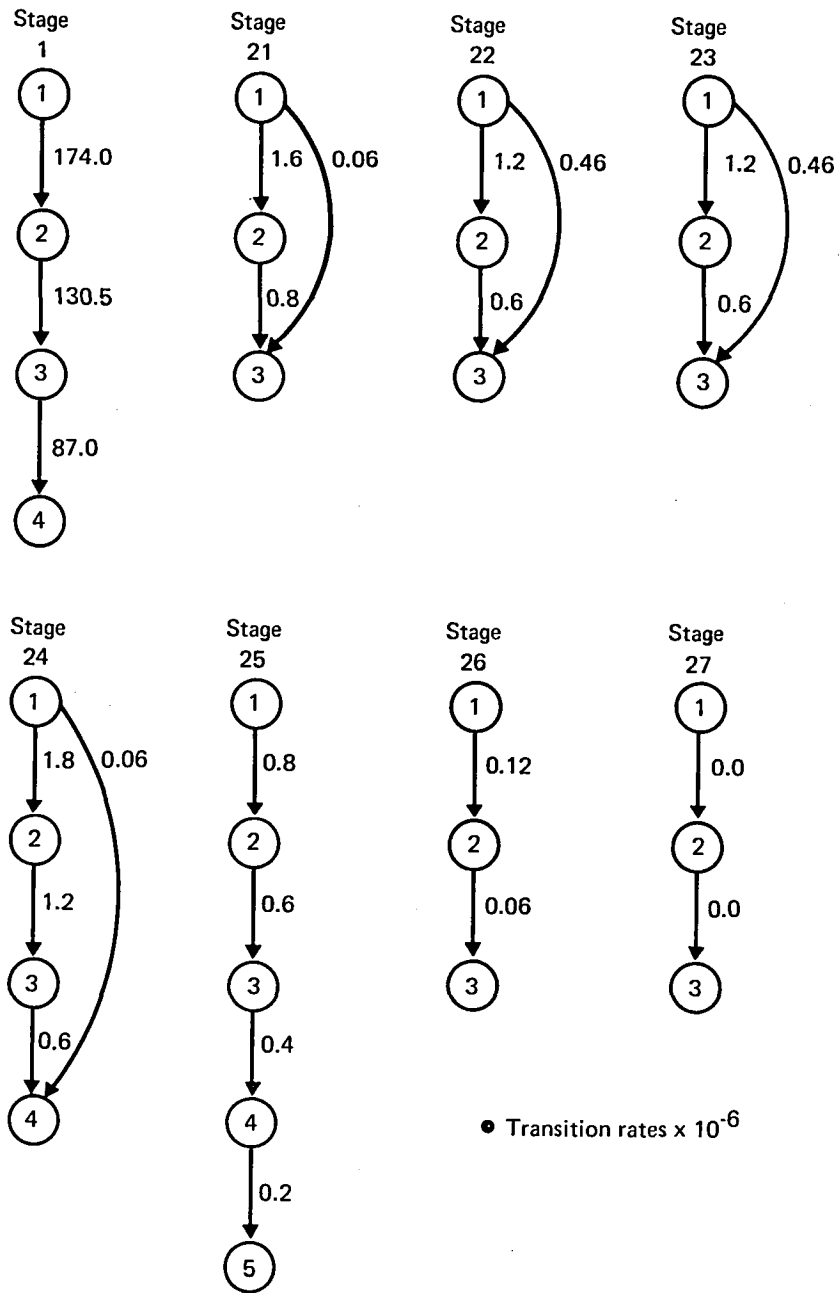

Figure 46. Lateral Control Markov Models

Table 18. Lateral Control Stage Success Configurations

Failures	Stage failure combinations that do not cause system failure
Single	Stage 21, or Stage 22, or Stage 23, or Stage 24
Dual	Stages 22 and 23, or Stages 21 and 24, or Stages 23 and 24, or Stages 21 and 23, or Stages 22 and 24, or Stages 21 and 22

The failure probabilities of the lateral control function using CARSRA are shown in table 19. The functional readiness for no module failed for the lateral control function is shown in table 20.

To check the failure probability of the lateral control function for the low-speed case, the outboard ailerons are included in the model. Stages 22 and 23 are changed to include the aileron lockout system and the outboard actuators (table 21). Figure 47 shows the revised Markov models for these two stages.

The failure probability of the lateral control function, which includes the outboard ailerons for a 1-hr flight, is 0.355×10^{-12} . Comparison of the low-speed case to the general case shows only a slight degradation in reliability.

Table 19. Lateral Control Failure Probability

Flight length (hours)	Failure probability
1.0	0.341×10^{-12}
2.0	0.266×10^{-11}
3.0	0.894×10^{-11}
4.0	0.211×10^{-10}
5.0	0.412×10^{-10}
6.0	0.712×10^{-10}
7.0	0.113×10^{-9}
8.0	0.169×10^{-9}
9.0	0.240×10^{-9}
10.0	0.329×10^{-9}

Table 20. Lateral Control Functional Readiness (No Modules Failed)

Time from start of flight (hours)	Functional readiness at time of flight
2.0	0.999637
4.0	0.999273
6.0	0.998910
8.0	0.998547
10.0	0.998184

Table 21. Lateral Control Stage Failures (Low-Speed Case)

Stage No.	Stage description	Stage failure
22	Right hand inboard and outboard aileron power control unit, cable, programmer, and lockout	Stage fails with the fourth actuator failure, lockout system, cable or programmer failure
23	Left hand inboard and outboard aileron power control unit, cable, programmer, and lockout	Stage fails with the fourth actuator failure, lockout system, cable or programmer failure

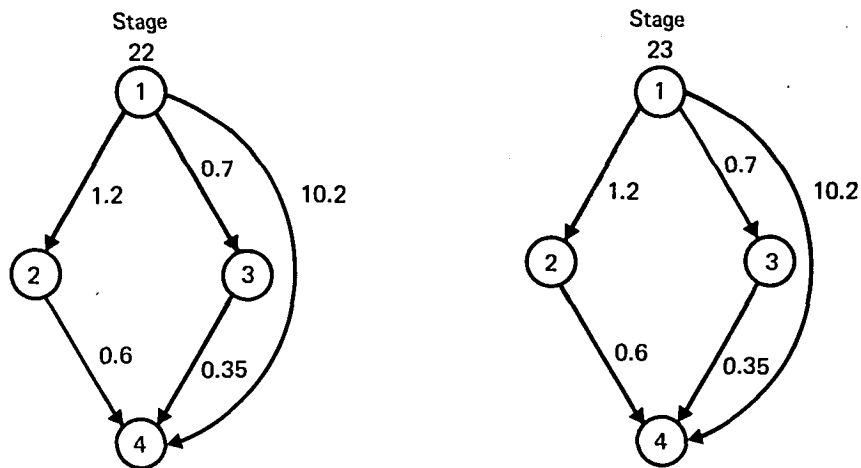

• Transition rates x 10⁻⁶

Figure 47. Lateral Control Markov Models for Outboard Ailerons

4.2.4.4 Rudder Control Reliability

On the basis of the stage identification (fig. 48), dependency tree (fig. 49), and Markov models (fig. 50), the stage failures are listed in table 22, the dependencies are listed in table 23, and success configurations are listed in table 24.

Table 22. Rudder Control Stage Failures

Stage No.	Stage description	Stage failure
Dependent stages		
1	Linkage to power control units	Stage fails with second linkage failure
2	Hydraulic supply	Stage fails with fourth hydraulic supply system failure
Nondependent stages		
21	Upper and lower rudder power control units	Stage fails with fourth actuator failure
22	Rudder trim input	Stage fails with trim/actuator/cable/trim knob failure
23	Rudder pedal input	Stage fails with second rudder pedal failure or forward quadrant/cable/aft quadrant failure
24	Feel, trim, and centering unit	Stage fails with second load path failure of feel, trim, and centering unit

Table 23. Rudder Control Module Dependencies

Dependent modules	Nondependent modules
11 →	221, 251
12 →	211, 231, 241, 252
13 →	212, 222, 242, 253
14 →	232, 243, 254

Table 24. Rudder Control Stage Success Configurations

Failures	Stage failure combinations that do not cause system failure
Single	Stage 22, or Stage 23

• Functional failure rates $\times 10^{-6}$

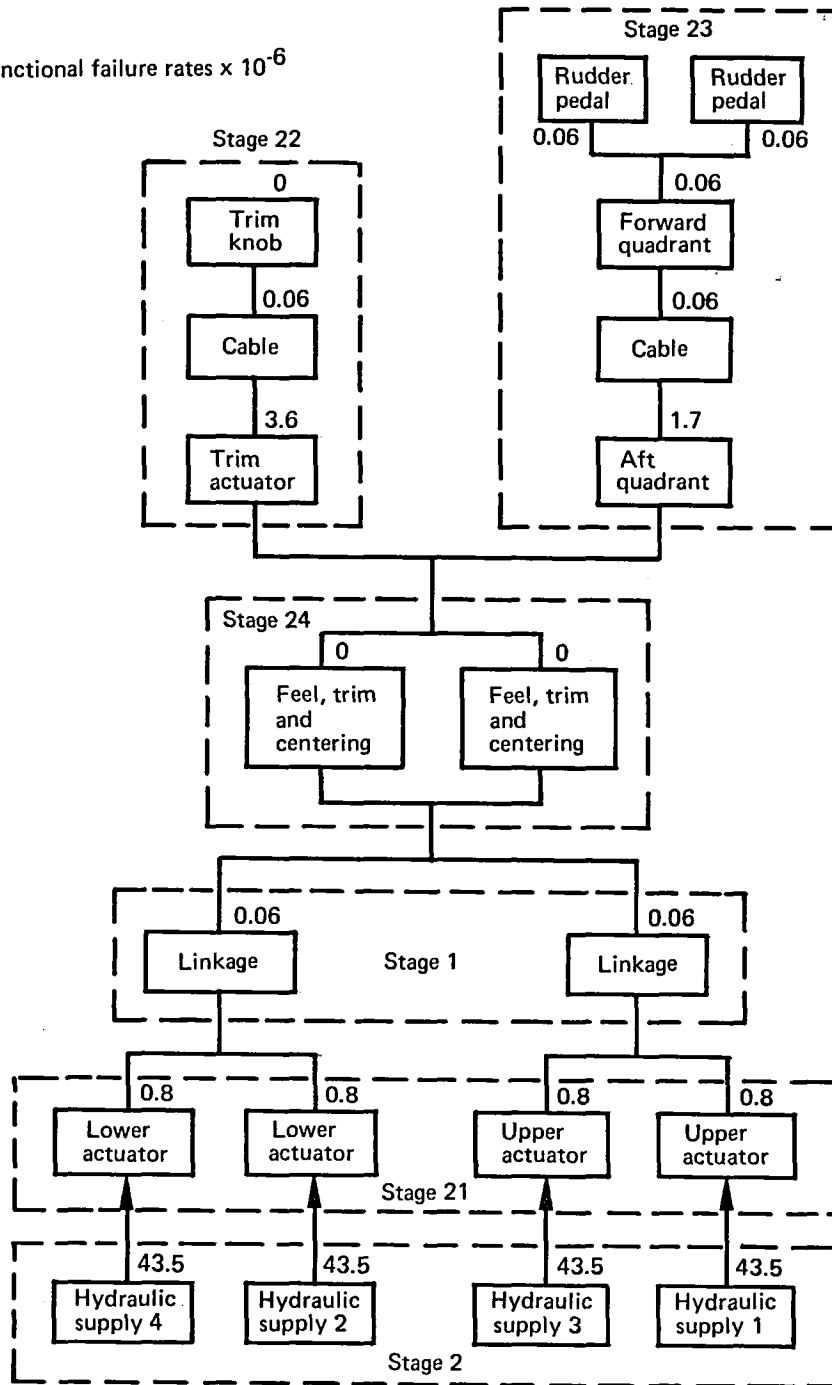
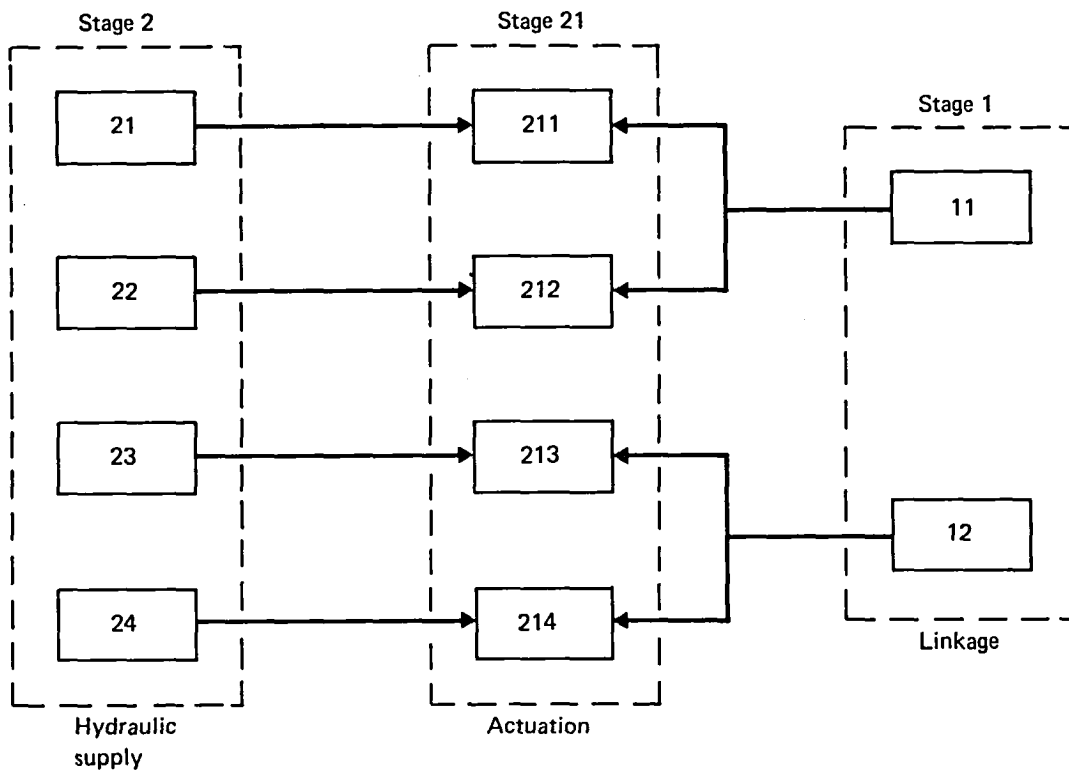

Figure 48. Rudder Control Stage Identification



Stage 22

 Trim input

Stage 23

 Pedal input

Stage 24

 Feel and trim

Figure 49. Rudder Control Dependency Tree

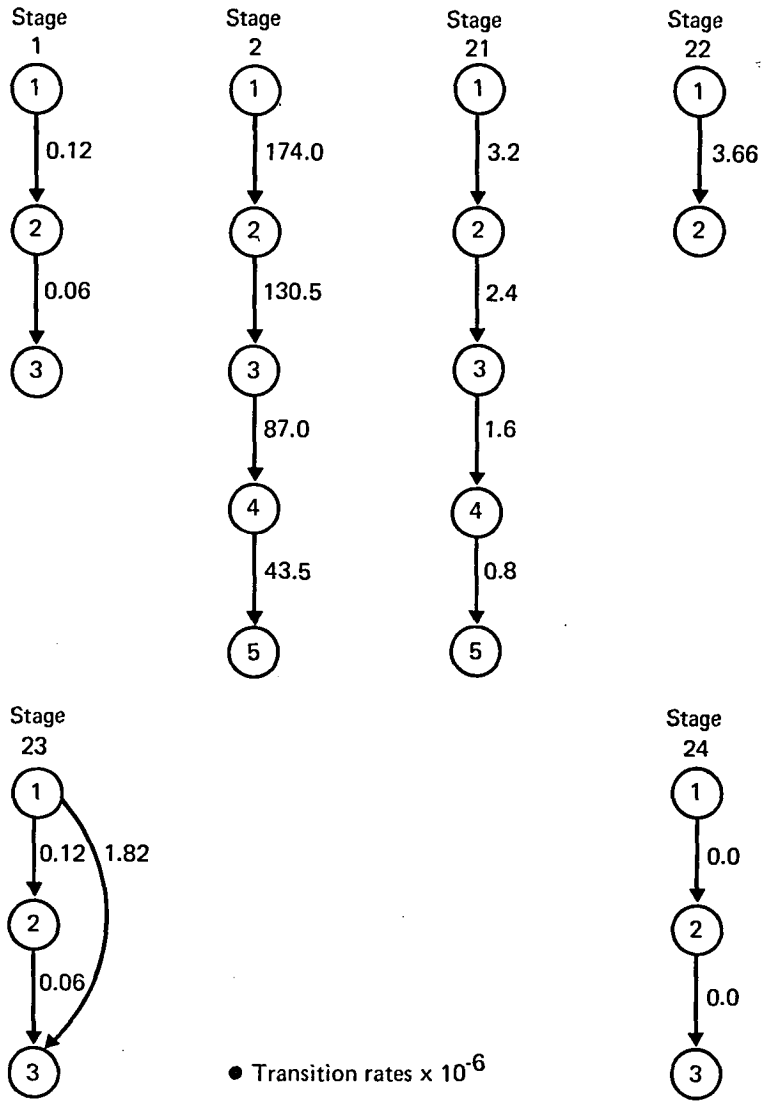

Figure 50. Rudder Control Markov Models

The failure probabilities of the rudder control function using CARSRA are shown in table 25. The functional readiness for no module failed for the rudder control function is shown in table 26.

The control function reliability for a 1-hr flight can be calculated using CRAM from the rudder success path diagram (fig. 51) developed from the dependency tree diagram (fig. 49) and the success configurations (table 24). The failure probability is equal to 1 minus system reliability.

$$\text{Failure probability for a 1-hr flight} = 0.6666 \times 10^{-11} \text{ (result from CRAM)}$$

This result compares closely with the CARSRA result of 0.6672×10^{-11} per 1-hr flight. In this case, the hydraulic supply failure combination for system failure with the fourth supply failure is the same for both CARSRA and CRAM.

Table 25. Rudder Control Failure Probabilities

Flight length (hours)	Failure probability
1.0	0.667×10^{-11}
2.0	0.267×10^{-10}
3.0	0.600×10^{-10}
4.0	0.107×10^{-9}
5.0	0.167×10^{-9}
6.0	0.240×10^{-9}
7.0	0.327×10^{-9}
8.0	0.427×10^{-9}
9.0	0.540×10^{-9}
10.0	0.667×10^{-9}

Table 26. Rudder Control Functional Readiness (No Modules Failed)

Time from start of flight (hours)	Functional readiness at time of flight
2.0	0.999634
4.0	0.999269
6.0	0.998903
8.0	0.998538
10.0	0.998172

SYSTEM CONSIDERED -

RUDDER CONTROL

SUCCESS PATHS

```

1 3 5
1 3 6
1 4 7
1 4 8
2 3 5
2 3 6
2 4 7
2 4 8
  
```

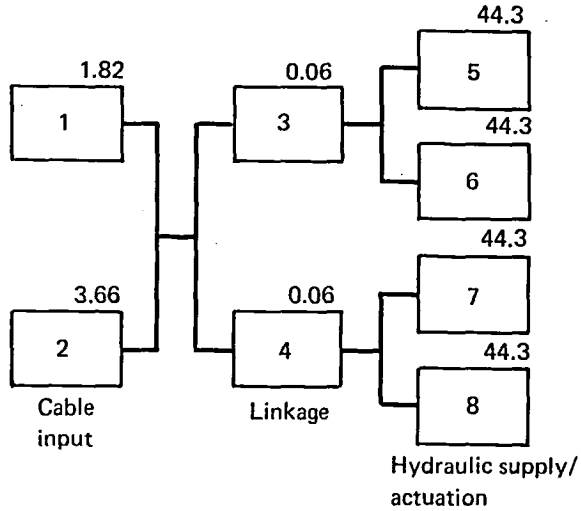

TIME = 0.1000000000000000D+01

COMP	FAILURE RATE	RELIABILITY
1	0.1820000000000000D-05	0.999998180001656D+00
2	0.3660000000000000D-05	0.999996340006698D+00
3	0.6000000000000000D-07	0.999999940000002D+00
4	0.6000000000000000D-07	0.999999940000002D+00
5	0.4430000000000000D-04	0.999955700981231D+00
6	0.4430000000000000D-04	0.999955700981231D+00
7	0.4430000000000000D-04	0.999955700981231D+00
8	0.4430000000000000D-04	0.999955700981231D+00

FAILURES	SYSTEM RELIABILITY	SUCCESS EVENTS	TOTAL EVENTS
0	0.999817216706902D+00	1	1
1	0.999999987226792D+00	9	9
2	0.999999999992921D+00	35	37
3	0.999999999993334D+00	77	93
4	0.999999999993334D+00	109	163

SYSTEM RELIABILITY = 0.999999999993334D+00

Figure 51. Rudder Control Success Path Model

4.2.4.5 Speed Brake Reliability

On the basis of the stage identification (fig. 52), dependency tree (fig. 53), and Markov models (fig. 54), the stage failures are listed in table 27, the dependencies are listed in table 28, and the success configurations are listed in table 29.

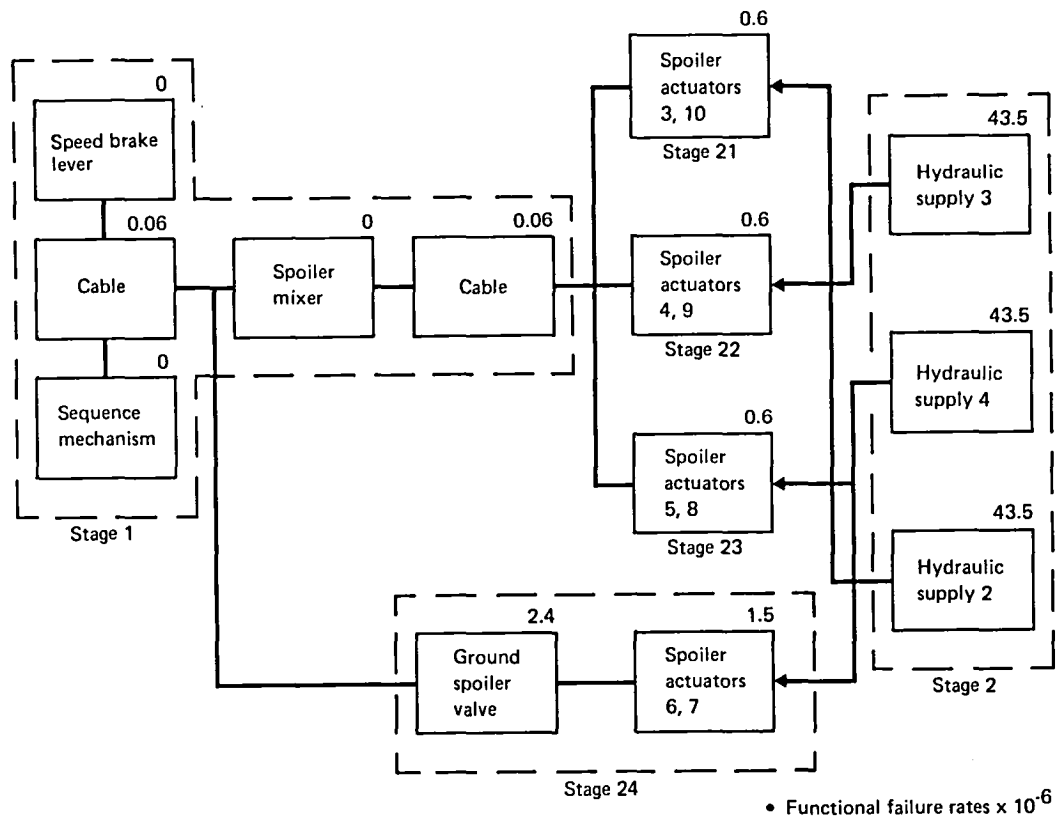

Figure 52. Speed Brake Stage Identification

Table 27. Speed Brakes Stage Failures

Stage No.	Stage description	Stage failure
Dependent stages		
1	Control input	Stage fails with speed brake lever/input cable/sequence mechanism, spoiler mixer/inboard spoilers cable failure
2	Hydraulic supply	Stage fails with second hydraulic system supply failure
Nondependent stages		
21	Spoiler power control units 3 and 10	Stage fails with power control unit 3 or 10 failure
22	Spoiler power control units 4 and 9	Stage fails with power control unit 4 or 9 failure
23	Spoiler power control units 5 and 8	Stage fails with power control unit 5 or 8 failure
24	Spoiler power control units 6 and 7	Stage fails with ground spoiler valve or power control unit 6 or 7 failure

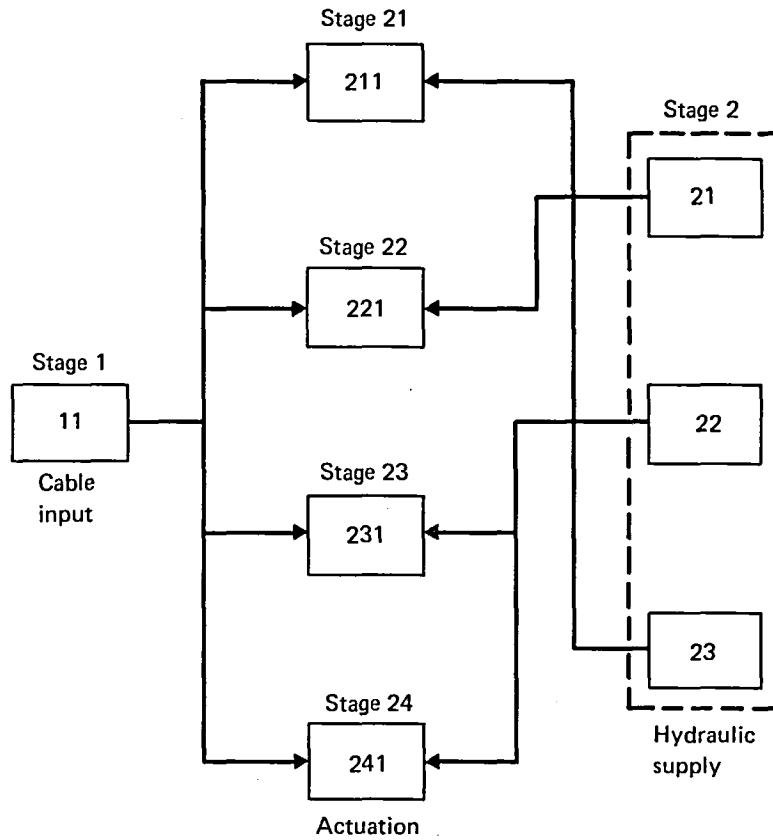
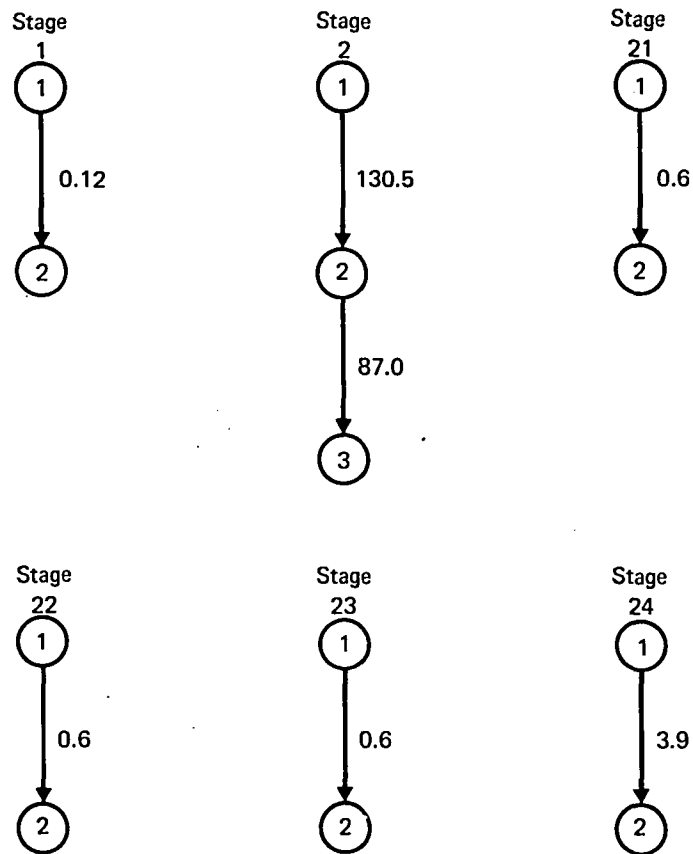

Figure 53. Speed Brake Dependency Tree

Table 28. Speed Brake Module Dependencies

Dependent modules	Nondependent modules
11 →	211, 221, 231, 241
21 →	221
22 →	231, 241
23 →	211



● Transition rates x 10⁻⁶

Figure 54. Speed Brake Markov Models

Table 29. Speed Brake Stage Success Configurations

Failures	Stage failure combinations that do not cause system failure
Single	Stage 21, or Stage 22, or Stage 23, or Stage 24
Dual	Stages 21 and 22, or Stages 21 and 23, or Stages 21 and 24, or Stages 22 and 23, or Stages 22 and 24, or Stages 23 and 24

The failure probabilities of the speed brake function using CARSRA are shown in table 30. The functional readiness for any failed hydraulic supply system and any two of four failed symmetrical spoiler pairs is shown in table 31, which also shows the failure probability of losing the speed brake function.

Table 30. Speed Brake Failure Probabilities

Flight length (hours)	Failure probability
1.0	0.126×10^{-6}
2.0	0.263×10^{-6}
3.0	0.412×10^{-6}
4.0	0.572×10^{-6}
5.0	0.743×10^{-6}
6.0	0.926×10^{-6}
7.0	0.112×10^{-5}
8.0	0.133×10^{-5}
9.0	0.154×10^{-5}
10.0	0.177×10^{-5}

Table 31. Speed Brake Functional Readiness

Time from start of flight (hours)	Functional readiness at time of flight	Failure probability at the time increment following	
		Failure probability	Hours
1.8	0.999990	0.283×10^{-7}	0.2
3.6	0.999979	0.653×10^{-7}	0.4
5.4	0.999968	0.111×10^{-6}	0.6
7.2	0.999958	0.165×10^{-6}	0.8
9.0	0.999947	0.228×10^{-6}	1.0

4.2.5 PFCS Analysis and Sensitivity

The primary flight control system (PFCS) reliability analysis was conducted using the same approach as that taken in the control function analyses. In this case, the dependency tree diagram can be constructed directly from the elevator control, lateral control, and rudder control stage identification diagrams (fig. 55). The corresponding Markov models (figure 56) have been changed slightly from those of the control functions. This was done to form a compact dependency tree to keep the number of successful configurations within limits. The stage failures are listed in table 32, the dependencies are listed in table 33, and success configurations are listed in table 34.

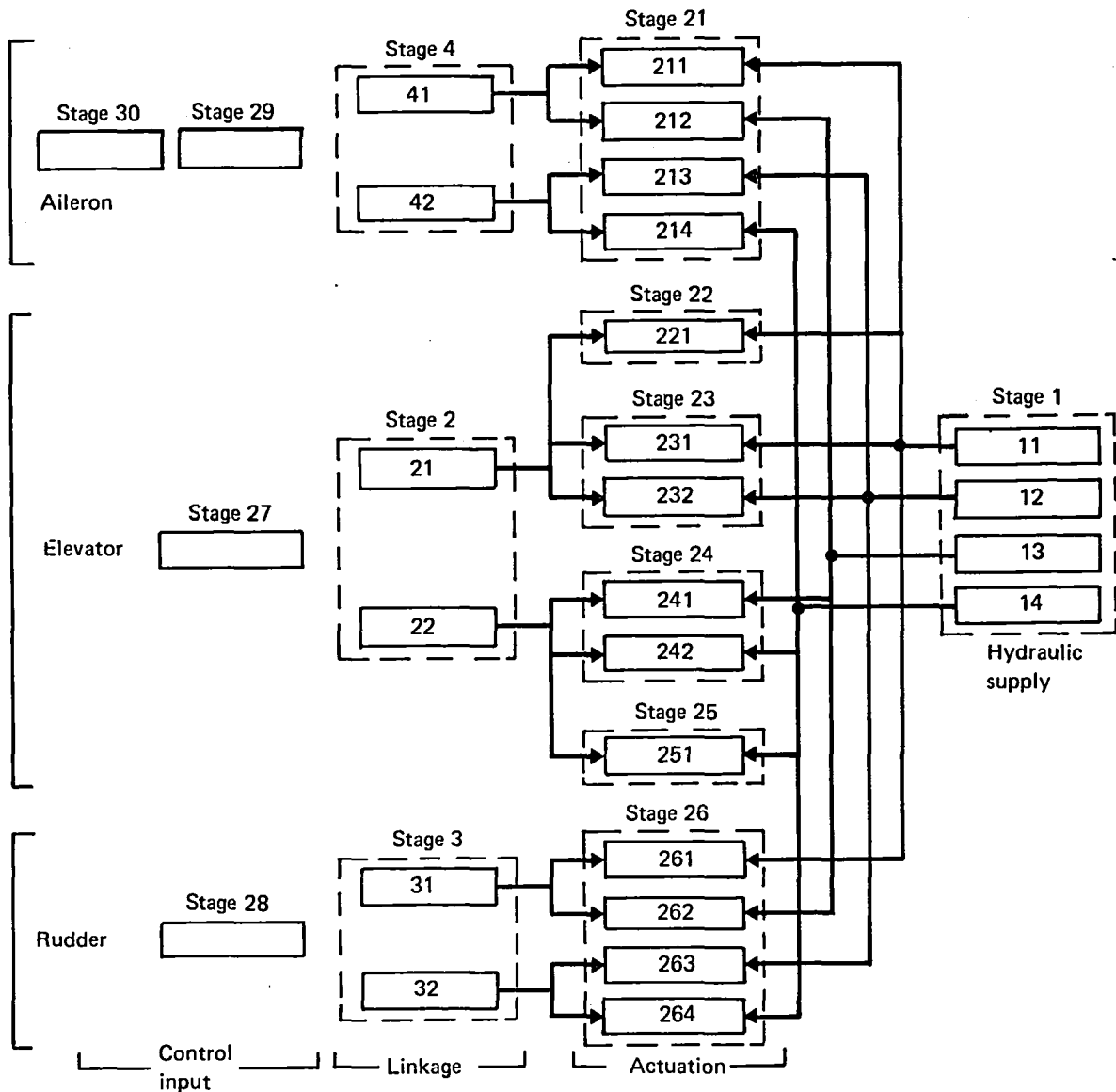

Figure 55. PFCS Dependency Tree

Table 32. PFCS Stage Failures

Stage No.	Stage description	Stage failure
<p>Dependent stages</p> <p>1</p> <p>2</p> <p>3</p> <p>4</p>	<p>Hydraulic supply</p> <p>Elevator linkage to inboard power control units</p> <p>Rudder linkage to power control units</p> <p>Left and right aileron programmer and cable</p>	<p>Stage fails with third hydraulic supply system failure</p> <p>Stage fails with fourth load path failure of the two linkages</p> <p>Stage fails with second linkage failure</p> <p>Stage fails with second cable/programmer failure</p>
<p>Nondependent stages</p> <p>21</p> <p>22</p> <p>23</p> <p>24</p> <p>25</p> <p>26</p> <p>27</p> <p>28</p> <p>29</p> <p>30</p>	<p>Left and right inboard aileron power control units</p> <p>Left outboard elevator actuator</p> <p>Right inboard elevator power control unit</p> <p>Left inboard elevator power control unit</p> <p>Right outboard elevator actuator</p> <p>Upper and lower rudder power control units</p> <p>Elevator control cable and forward quadrant</p> <p>Rudder pedal and trim control</p> <p>Aileron control cable</p> <p>Aileron control wheel</p>	<p>Stage fails with fourth actuator failure</p> <p>Stage fails with cable, pushrod, or actuator failure</p> <p>Stage fails with second actuator failure</p> <p>Stage fails with second actuator failure</p> <p>Stage fails with cable, pushrod, or actuator failure</p> <p>Stage fails with fourth actuator failure</p> <p>Stage fails with second cable/forward quadrant failure</p> <p>Stage fails with rudder pedal/forward quadrant/cable/aft quadrant failure, or trim actuator/trim cable failure</p> <p>Stage fails with second cable failure</p> <p>Stage fails with second control wheel failure</p>

Table 33. PFCS Module Dependencies

Dependent modules	Nondependent modules
11 →	211, 221, 231, 261
12 →	213, 232, 263
13 →	212, 241, 262
14 →	214, 242, 251, 264
21 →	221, 231, 232
22 →	241, 242, 251
31 →	261, 262
32 →	263, 264

Table 34. PFCS Stage Success Configurations

Failures	Stage failure combinations that do not cause system failures
Single	Stage 22, or Stage 23, or Stage 24, or Stage 25
Dual	Stages 22 and 23, or Stages 22 and 25, or Stages 24 and 25

The failure probabilities of the PFCS function using CARSRA are shown in table 35. The functional readiness for no modules failed for the PFCS function is shown in table 36.

Table 35. PFCS Failure Probabilities

Flight length (hours)	Failure probability
1.0	0.726×10^{-11}
2.0	0.303×10^{-10}
3.0	0.712×10^{-10}
4.0	0.132×10^{-9}
5.0	0.215×10^{-9}
6.0	0.321×10^{-9}
7.0	0.454×10^{-9}
8.0	0.614×10^{-9}
9.0	0.805×10^{-9}
10.0	0.103×10^{-8}

Table 36. PFCS Functional Readiness (No Modules Failed)

Time from start of flight (hours)	Functional readiness at time of flight
2.0	0.999618
4.0	0.999213
6.0	0.998855
8.0	0.998474
10.0	0.998093

As defined in section 4.3.2, the PFCS includes three functions that control the airplane about the pitch, roll, and yaw axes: the elevator, aileron, and rudder. An assessment is made in this section of the contribution of each control function failure probability to the PFCS failure probability. A simple summation of the control function failure probabilities from section 4.3.4 to obtain a total PFCS failure probability is not valid because some modules are common to all control functions in the reliability block diagrams. The control function for the flight compartment control inputs and the surface actuation systems, however, are completely independent. But, the four hydraulic systems provide the power supply to all the control functions. The four modules for hydraulic supply systems 1, 2, 3, and 4 form a dependent stage that is common to all control function dependency trees.

By starting instead with the combined PFCS dependency tree (fig. 55) in this section, the diagram can be split into separate control function input stages, actuation stages, and the combined hydraulic supply stage. The contribution of elevator control input and actuation, aileron control input and actuation, rudder control input and actuation, and the hydraulic supply to the combined PFCS can be made. This is achieved by running the CARSRA program separately for each control function input and actuation system and for the hydraulic supply.

The results of this sensitivity task are shown in table 37.

The rudder control function (less power supply) shown in table 37 contributes more than 92% to the total PFCS failure probability. In the control function analysis in section 4.3.4 the failure probability for the rudder control including power supply is 0.6672×10^{-11} per hour-flight. By inspecting the functional failure rates shown on the stage identification diagram (fig. 48), the input control, rudder pedal, and rudder trim combination is the contributing factor. In the aileron control and elevator control systems, the hydraulic power supply failure probability is a significant contributor to each control function probability.

Table 37. PFCS Input and Actuation Failure Probabilities

Nondependent functions	Failure probability, 1-hr flight	Percent of total
Elevator control input and actuation	0.215×10^{-11}	3.0
Aileron control unit and actuation	0.0021×10^{-11}	0.3
Rudder control input and actuation	0.6665×10^{-11}	92.2
Hydraulic supply (three or more systems failed)	0.0329×10^{-11}	4.5
PFCS	0.7230×10^{-11}	100.0

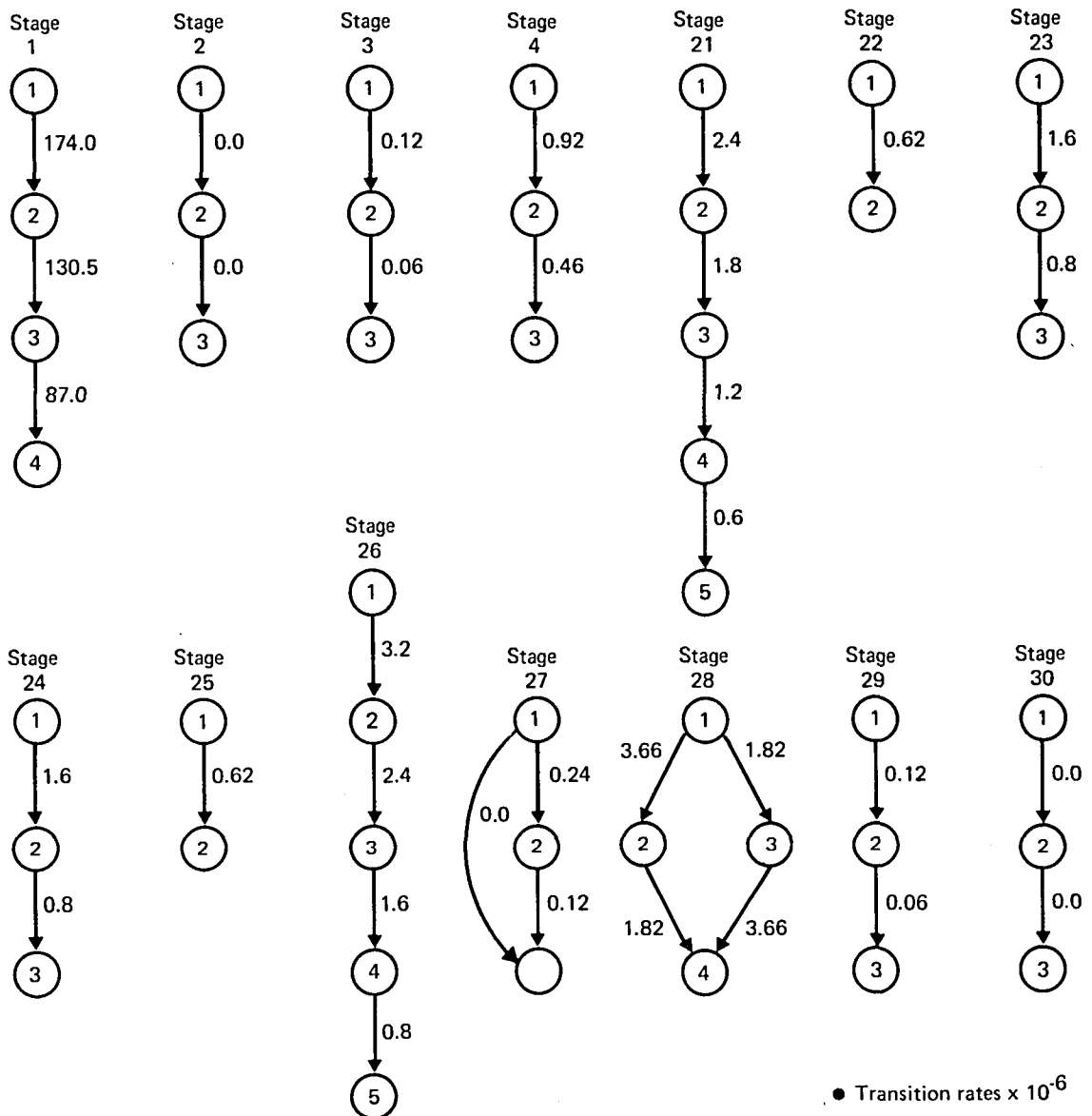

Figure 56. PFCS Markov Models

4.3 MAINTENANCE COST ASSESSMENT

The total primary flight control system (PFCS) maintenance cost consists of delay and cancellation costs plus direct maintenance cost. The latter includes scheduled and unscheduled line maintenance costs and overhaul shop costs. To determine the total PFCS maintenance costs, the available man-hour and delay rate data at the component level were reviewed. The costs associated with these rates were determined, then the individual costs were totaled.

Data were extracted from large domestic trunk and international carrier airlines. Any comparison of maintenance costs between airlines will usually vary because of many factors, including differing maintenance philosophies, varying route structures, fleet maturity, geographic location, and accounting methods. Such cost variations cannot be used to assess airline efficiency or to compare airplane types.

To help reveal the reasons for cost variations and the methods for cost accumulation and the evolution of the maintenance program, the maintenance process categories and terms are summarized in the following paragraphs.

When any new model of airplane is introduced, the manufacturer, customer airline, and Government regulatory agencies convene to produce an initial set of maintenance guidelines from which each airline designs its maintenance program. In the United States, the Federal Aviation Administration (FAA) issues an advisory circular (an MRB report generated by the maintenance review board), which is closely followed by the domestic airlines and many overseas airlines in developing their individual maintenance programs. Each program is separately approved by the FAA prior to placing the new model into service. The individual programs are specifically tailored to an airline's maintenance philosophy, route structure, etc. But, they conform closely to the MRB recommendations for maintenance processes and scheduled time periods.

Although the airlines introduce service on new types of airplanes with scheduled maintenance frequencies recommended by the MRB, they escalate the frequencies periodically (upon FAA approval) as they gain experience with the airplane. At a given point in time, therefore, an airline that has escalated its maintenance intervals several times over a number of years will experience lower scheduled maintenance cost than an airline introducing that model of airplane. The escalation process has a profound effect on reducing scheduled maintenance costs, and airlines strive for increases in interval times as experience permits. Interval escalation has little effect on unscheduled maintenance costs because this is controlled primarily by equipment reliability.

The term scheduled maintenance, sometimes called preventive or routine maintenance, can be defined as maintenance performed at intervals to retain an item in a serviceable condition by actions such as systematic inspection, detection, replacement of wear-out items, adjustment, calibration, and cleaning. The scheduled maintenance cost includes only resources spent for planned maintenance activities. Any resources spent on problems found during planned work become an unscheduled maintenance cost.

Unscheduled maintenance, sometimes referred to as corrective or nonroutine maintenance, is defined as maintenance performed to restore an item to a satisfactory condition by correcting a known or suspected malfunction or defect.

Maintenance processes have evolved over the years to the point where three primary processes are in use on today's jet transport aircraft. They are:

1. Time-controlled (hard time) overhaul—Equipment or structure is overhauled in accordance with a plan that monitors time histories of individual items. The monitoring system is used to schedule the removal of items before they exceed a specified time limit. Time-controlled overhaul is a preventive maintenance process and is used primarily for structural inspection of the airframe. On infrequent occasions it is used to inspect system components that exhibit defined wear-out patterns or life limits.
2. On-condition maintenance—Repetitive inspections or tests determine the serviceability condition of units, systems, or portions of structure (corrective action is taken when required by item condition). On-condition maintenance is a preventive maintenance process widely used for aircraft components and systems to reduce the consequences of malfunction by detecting unsatisfactory conditions or operational degradation prior to complete failure.
3. Condition-monitored maintenance—Data on all specified items in service are analyzed to determine if technical resources are required. Condition monitoring is a corrective maintenance process that allows failures to occur and relies upon an analysis of operating experience information to indicate any need for appropriate action. Action may involve changing the maintenance procedure, redesigning the item, or transferring the item to a different maintenance process. It is a widely used process for items that have no effect on safety and have low monetary consequence.

The segregation of items into one of the three maintenance processes is accomplished by a system known currently as maintenance steering group II (MSG-II). This is a logic-oriented process using a decision tree model to assess the consequences of an aircraft operation failure and, based on the severity of the consequence, to assign the item to an appropriate maintenance process. This system is used to develop the initial maintenance program recommendations prior to certification of the airplane model. Individual airlines will modify the basic recommendations to suit their specific needs subject to Government regulatory agency approval.

A typical breakdown of the direct maintenance cost for a model 747 operator having complete in-house maintenance and repair capability is shown in table 38. While some costs occur for scheduled maintenance on a routine basis, most direct maintenance costs are categorized as nonroutine or unscheduled.

Scheduled line maintenance for the PFCS includes periodic inspections and checks scheduled as part of the "C" check (see appendix E). Unscheduled line maintenance can be categorized as maintenance to correct discrepancies found either during scheduled maintenance or reported as in-flight malfunctions. Both the scheduled and unscheduled line maintenance are conducted on the airplane. The on-airplane activity in the overhaul shop is mostly confined to structural inspection. The off-airplane shop activity for the PFCS applies to the components removed for overhaul and repair. For all PFCS equipment, such maintenance is nearly all unscheduled because of the predominance of the condition monitoring process.

Maintenance cost is based on a unit of 1,000 flight-hours. Costs are then calculated on a calendar basis by including an annual airplane use of about 3,500 hr for a typical 747 operator. Scheduled maintenance costs, line maintenance costs, overhaul shop costs, and delay and cancellation costs are assessed in the following sections.

Table 38. Direct Maintenance Cost Categories

Line maintenance costs		
On-airplane		
Preflight checks	}	Scheduled
Transit/turnaround inspections		
A-checks		
C-checks		
Corrective actions generated by scheduled maintenance and flight reports		Unscheduled
Shop maintenance costs		
On-airplane		
D-checks, structural inspection	}	Scheduled and non-routine repair work
Flight control surfaces		
Off-airplane		
Component overhaul		Scheduled and unscheduled

4.3.1 Scheduled Line Maintenance Cost

The scheduled line maintenance for flight controls involves the inspections and functional checks performed at the "C" check intervals. The inspection items of specific interest are the mechanical portions of the PFCS, which rarely fail.

The cost depends on the number of checks. Appendix E lists flight control checks, the C-check intervals at which the checks must be accomplished, and the estimated man-hours required to make the checks. The check interval is established separately for each airline according to the approved maintenance program, as explained in this section. For the U.S. domestic 747 fleet the C-check interval ranges from 2,000 to 3,600 hr. The fleet average, 2,660 hr, is used in the calculation of the scheduled line maintenance cost.

The inspection items from appendix E have been summarized in table 39, which shows the man-hours required per airplane in terms of the C-check interval or hours flown.

By applying a C-check interval of 2.66 per 1,000 hr: total man-hours per 1,000 hr = 17.75 hr.

With a 1978 labor rate of \$10.87 per hour, the scheduled maintenance cost is \$192.94 per 1,000 hr. One airline, in support of requests for check time extensions from their regulatory agency, embarked on a component sampling program. In this case, mechanical components were actually removed from the airplane and checked for wear and corrosion. With little evidence of component degradation, the check interval was escalated and the costs for scheduled maintenance reduced.

Scheduled maintenance is a production operation and can be planned for and allocated a fixed budget. The budget is then amortized over a certain time period, and cost underruns, if any, result as an internal profit. Since actual airline costs on a flight-hour basis at the component or system level are not available, the above scheduled maintenance cost should be treated as an estimate only.

Table 39. Schedule Maintenance Man-hours

Check item	Manhours required and frequency			
	C check	2C check	4C check	Other
-02 Aileron control mechanisms	7.3	4.2	0.5	
-04 Spoiler control mechanisms	3.9		1.0	2.0 (4,000 hr F/C)
-09 Elevator control mechanisms	7.8		2.0	5.0 (4,000 hr F/C)
-11 Rudder control mechanisms	5.0		0.9	1.0 (4,000 hr F/C)
-12 Rudder pedals			0.4	
-13 Stabilizer trim control			0.5	
-14 Stabilizer actuating mechanism	8.0	0.8		6.0 (4,000 hr F/C)
-19 Forward rudder quadrant				2.0 (9,000 hr)
-20 Forward elevator quadrant				2.0 (9,000 hr)
-21 Cables-fin and stabilizer				3.0 (9,000 hr)
Totals	Manhours			
Every C check (C)	= 32.0			
Every second C check (2C)	= 5.0			
Every fourth C check (4C)	= 5.3			
Every 4,000 hr	= 14.0			
Every 9,000 hr	= 7.0			

4.3.2 Unscheduled Line Maintenance Cost

Unscheduled line maintenance costs result basically from the man-hours used to remove and replace equipment on the airplane and the labor rate associated with such work. Actual removal and replacement times, as recorded by one airline over a period of 3 years (from 1972 to 1975) are shown in table 40. A "flight control general" category is assigned because some unscheduled line maintenance consists of troubleshooting that does not pinpoint the problem at the LRU level. Some problems are deferred for later actions while other problems resulting from pilot reports are difficult to detect on the ground. To generate man-hours per 1,000 flight-hours, the average removal and replacement times are multiplied by the unscheduled removal rate in removals per 1,000 flight-hours. For general items, such as tubing and wiring, where no removal rates are known, the removal and replacement times are summed over the time period and divided by the flight-hours flown by that airline in the same time period.

$$\text{Unscheduled line labor cost} = \text{Average man-hours to remove and replace} \times 1978 \text{ labor rate } (\$10.87 \text{ per hour}) \times \text{removal rate (removals per 1,000 flight-hours)}$$

$$\text{or} \\ = \text{Accumulated man-hours to remove and replace} \times \text{labor rate per 1,000 flight-hours during the period}$$

Table 41 shows the computed unscheduled line maintenance cost for each control function.

Table 40. Line Maintenance Man-Hours

Control system	Total man-hours	Average man-hours per action	Removals per 1,000 flight hours	Man-hours per 1,000 flight hours
Flight control—general	96.2	—	—	0.930
Elevator control				
Hydraulic hose/line/fitting	8.9	—	—	0.086
Feel computer	—	8.5	0.1254	1.066
Feel control unit	—	5.5	0.0016	0.009
Power control unit	—	11.8	0.1600	1.888
Indicating/warning	2.4	—	—	0.023
Total				3.072
Stabilizer trim				
Hydraulic hose/line/fitting	11.4	—	—	0.110
Electrical connector/wiring	1.3	—	—	0.013
Hydraulic motor	—	8.3	0.0408	0.339
Control module	—	12.4*	0.0574	0.712
Indicating/warning	0.5	—	—	0.005
Total				1.179
Lateral control				
Trim actuator	—	6.5	0.0130	0.085
Outboard aileron lockout actuator	—	3.5	0.0160	0.056
Power control unit	—	31.4	0.1484	4.660
Central control actuator	—	12.4*	0.0600	0.744
Flight control shutoff valve	—	6.6	0.0462	0.305
Indicating/warning	8.0	—	—	0.077
Spoiler actuator	—	6.5	0.1530	0.995
Total				6.922
Rudder control				
General	4.0	—	—	0.039
Mechanical linkage	2.5	—	—	0.024
Ratio servo (actuator)	—	17.9	0.2238	4.006
Ratio control unit	—	6.4	0.3226	2.065
Power control unit	—	3.8	0.1154	0.439
Indicating/warning	69.3	—	—	0.639
Total				7.212
Speed brakes				
General	2.6	—	—	0.025
Ground spoiler control valve	—	10.5	0.0024	0.025
Ground spoiler actuator	—	10.0	0.0194	0.194
Total				0.244

*Data not available, estimated values used

Table 41. Unscheduled Line Maintenance Costs

Control system	Line labor (\$/1,000 flight hr)
Flight control—general	10.11
Elevator control	33.39
Stabilizer trim	12.82
Lateral control	75.24
Rudder control	78.39
Speed brakes	2.65
Total	212.60

4.3.3 Overhaul Shop Maintenance Cost

Components removed from the airplane are sent to the main base overhaul shop where initial testing is carried out, when required, and parts are then overhauled. The two significant cost elements are labor to overhaul and test the components and materials to repair and refurbish them.

The cost accounting associated with components that move through the overhaul shop is not specifically accumulated by airplane type or airplane system. The shops are arranged by the ability to handle similar types of equipment such as hydraulics or electrical. Thus, flight control components being overhauled most likely will be from different types of airplanes in the fleet and spread through more than one overhaul shop.

Some airlines, however, do keep track of components for cost purposes at the airline stock number level. The stock number is usually identified with a particular component used on a particular airplane.

Data for overhaul shop maintenance cost were obtained from one airline that identified cost with particular 747 flight control components. Costs for both labor and material were accumulated over a 7-month period. In order to equate these costs to a flight-hour basis, the flight-hours flown during the same period of time were used.

The 1978-dollar shop costs are shown in table 42, which also shows costs obtained for some components from two other airline sources. In these two cases, labor man-hours per shop visit and material cost (for 1977) per shop visit were available. The costs per 1,000 flight-hours were generated as follows:

- o Shop labor = Labor man-hours per visit x 1978 labor rate (\$10.87 per hour) x removal rate (removals per 1,000 flight-hours)
- o Shop material = Material cost per visit x removal rate (removals per 1,000 flight-hours) x inflation factor (1977-1978 = 1.086)

An attempt was made to identify costs of overhauling flight control cables and pulleys. Since these items will most likely be deleted in future flight control designs, their cost is of special interest. The airline costs for cables and pulleys are available only at a whole-fleet level, in this case comprising six different airplane types. These costs were then factored by the ratio of 747 airplanes to the fleet. This may not be an accurate assessment, but should reflect cable and pulley costs in relation to other flight control component costs.

The costs between airlines are expected to vary because accurate costs are difficult to assess because of the low overhaul rate of the mechanical and hydraulic components. For example, for an actuator with a removal rate of 100 per 10⁶ flight-hours and a fleet of 10 airplanes flying 30,000 hr per year, the overhaul shop will be repairing three actuators in that year. Electronic equipment, however, has a much higher flow rate through the overhaul shop and the associated costs can be assessed more accurately.

Table 42. Overhaul Shop Maintenance Costs

Control system	Shop labor cost (\$/1,000 flight hour)	Shop materials cost (\$/1,000 flight hour)	Total
General (pulleys, cables)	4.84	13.23	18.07
Elevator control			
Feel actuator	1.80 (8.99)	2.26 (0.0)	
Feel computer	10.20 (80.83)	6.24 (123.66)	
Power control unit	49.81 (221.17)	153.86 (270.35)	
Total	<u>61.81</u>	<u>162.36</u>	224.17
Stabilizer trim			
Drive mechanism	5.70	0	
Control module	11.67	105.36	
Total	<u>17.37</u>	<u>105.36</u>	122.73
Lateral control			
Trim actuator	3.31 (0.93)	0 (0.08)	
Flight control shutoff valve	17.11 (2.59)	11.62 (0.0)	
Central control actuator	45.61	274.92	
Outboard aileron lockout actuator	6.30 (0.28)	.56 (0.0)	
Aileron programmer	11.58	3.01	
Inboard aileron power control unit	23.41 (53.39)	195.74 (213.30)	
Outboard aileron power control unit	10.20	350.80	
Spoiler differential (mixer)	11.40	6.31	
Spoiler actuator	4.80 (7.82)	10.30 (0.0)	
Total	<u>133.72</u>	<u>853.26</u>	986.98
Rudder control			
Power control unit	90.31 (101.86)	618.01 (1335.46)	
Rudder ratio servo actuator	14.10 (18.68)	2.55 (0.0)	
Rudder ratio control unit	26.41 (12.73)	56.66 (23.49)	
Total	<u>130.82</u>	<u>677.22</u>	808.04
Speed brakes			
Sequence mechanism	2.10	19.85	
Ground spoiler actuator	15.31	5.31	
Total	<u>17.41</u>	<u>25.16</u>	42.57

NOTE: Figures in parentheses are costs from two other airline sources

4.3.4 Delay and Cancellation Costs

The mechanical delays and cancellations of the 747 fleet during a number of revenue flights can be shown as the percentage of flights departing on time (schedule reliability). This reliability is a useful measure of the airplane's mechanical operating performance. Details of delays and cancellations are readily available in the airline reports for assessing performance.

The written accounts of delays and cancellations are charged, where possible, to equipment at the line-replaceable unit level. A delay can be charged to a component whether it is replaced or not. Troubleshooting that delays a flight departure may result in equipment being tagged inoperative if it is not dispatch-critical. In this case, the problem will be deferred to a time allotted for scheduled maintenance. In some cases, a pilot report will initiate a maintenance action but fail to pinpoint the problem. If a delay results, it is charged to a general category within the airplane system involved.

The delays and cancellations for the PFCS have been tabulated at the component level and general subject level (table 43). There were 234,518 revenue departures for the 747 fleet during the reporting period of 1977.

Table 43. Delay and Cancellation Rates for 747 Fleet During 1977

Control system	Delays per 1,000 departures	Cancellations per 1,000 departures
Flight control general	0.092	0
Elevator control		
General	0.015	0
Hydraulic hose/line/fitting	0.013	0
Mechanical linkage/cable	0	0.0045
Feel actuator	0.002	0
Feel computer	0.055	0.0045
Feel unit	0.004	0
Power control unit	0.032	0
Indicating /warning	0.009	0
Total	0.130	0.009
Stablizer Trim		
General	0.041	0
Hydraulic hose/line/fitting	0.026	0
Mechanical linkage/cable	0	0.0045
Electrical connector/wiring	0.019	0
Hydraulic motor	0.006	0
Control module	0.050	0.0045
Indicating/warning	0.004	0
Total	0.146	0.009
Lateral control		
General	0.042	0
Trim actuator	0.013	0
Load limiter	0.002	0
Lockout actuator	0.058	0
Aileron power control unit	0.015	0.009
Hydraulic hose/line/fitting	0.023	0
Electrical connector/wiring	0.057	0
Mechanical linkage	0.008	0
Central control actuator	0.002	0
Flight control shutoff valve	0.038	0
Spoiler actuator	0.043	0
Indicating/warning	0.004	0
Total	0.305	0.009
Rudder control		
General	0.121	0.009
Hydraulic hose/line/fitting	0.004	0
Electrical connector / wiring	0.006	0
Ratio servo (actuator)	0.135	0
Ratio control unit	0.085	0
Power control unit	0.030	0
Indicating warning	0.043	0
Total	0.424	0.009
Speed brakes		
General	0.011	0
Hydraulic hose/line/fitting	0.017	0
Ground spoiler actuator	0.036	0
Total	0.064	0

The costs associated with delays and cancellations are passenger handling costs, extra crew costs, and lost passenger revenue. An algorithm developed to assess these costs (see appendix F) makes use of inputs from several airlines on their estimated costs for different airplane types. A computer program is now available to handle the many variables. For each 747 flight control system, table 44 shows the average delay time and the results from the computer program for delay and cancellation costs. The calculated cost per delay-hour for flight control components averages \$1,954. The cancellation costs consist of delay costs up to the time the flight is finally cancelled plus the costs resulting from the cancelled flight. A figure of \$13,058 per cancellation results when the cancellation occurs after a delay time of 5 hr.

Table 44. Delay and Cancellation Costs

Control system	Average delay time (hours)	Delay cost (\$/1,000 flight hours)	Cancellation cost (\$/1,000 flight hours)
Flight control—general	1.52	65.07	0
Elevator control	2.41	145.76	27.98
Stabilizer trim	2.68	182.04	27.98
Lateral control	3.75	532.13	27.98
Rudder control	2.27	447.79	27.98
Speed brakes	1.45	43.18	0

4.3.5 Maintenance Cost Summary

The maintenance costs at the PFCS level are summarized in table 45. To put these costs in perspective, the following subsections compare the PFCS and airplane line, shop, delay, and cancellation costs; PFCS costs and automatic flight control costs; and scheduled and unscheduled costs.

Table 45. Maintenance Cost Summary

System maintenance	Line labor	Shop labor and material	Delay and cancellations	Total maintenance cost
Unscheduled maintenance				
Flight control—general	10.11	18.07	65.07	93.25
Elevator control	33.39	224.17	173.74	431.30
Stabilizer trim	12.82	122.73	210.02	345.57
Lateral control	75.24	986.98	560.11	1,622.33
Rudder control	78.39	808.04	475.77	1,362.20
Speed brakes	2.65	42.57	43.18	88.40
Total FCS (\$/1,000 flight hours)	212.60	2,202.56	1,527.89	3,943.05
Scheduled maintenance Estimated PFCS cost =	\$192.94/1,000 flight hours			

4.3.5.1 PFCS Costs

The major contributor to total PFCS cost is the component shop labor and material costs (55%). This compares with total airframe shop costs, an estimated 71% of the total maintenance cost (fig. 57). The PFCS delay and cancellation costs contribute a greater share to the total PFCS cost in comparison with the airframe cost breakdown. PFCS delay and cancellation costs of \$1,528 represent 40% of the PFCS total unscheduled maintenance cost; airframe delay and cancellation costs represent an estimated 13% of the total airframe unscheduled maintenance cost. The high PFCS delay and cancellation costs are a combination of higher than average delay times and the dispatch criticality of the system.

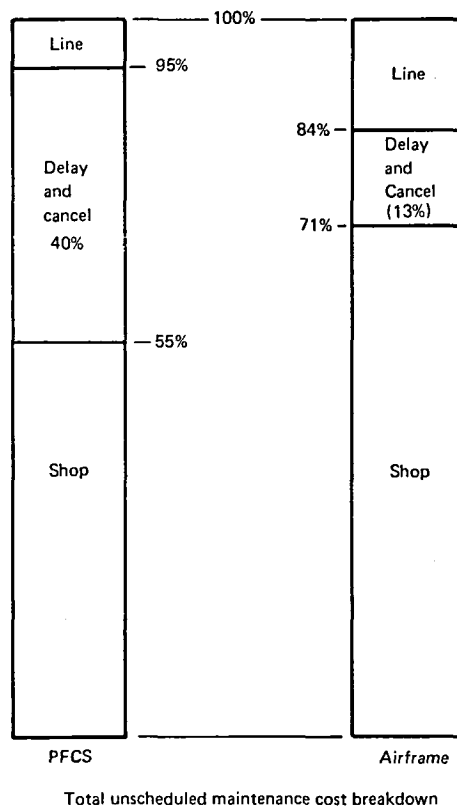

Figure 57. PFCS and Airframe Maintenance Cost

4.3.5.2 PFCS and AFCS Costs

Unscheduled line and shop costs for the PFCS and the automatic flight control system (AFCS), for ATA Chapter 22 components only, are about the same. The PFCS delay and cancellation costs, however, are more than 10 times higher than the AFCS costs for the reasons given in section 4.3.5.1.

4.3.5.3 Scheduled and Unscheduled Maintenance

The scheduled maintenance cost for the PFCS, estimated at \$192.94 per 1,000 flight-hours, is about 90% of the line labor cost. An industry breakdown of direct maintenance cost at the total airplane level shows that line maintenance cost is \$31.50 per flight-hour and periodic scheduled maintenance cost (A and C checks) is \$23.58 per flight-hour, or a 75% ratio of scheduled to unscheduled cost for line labor.

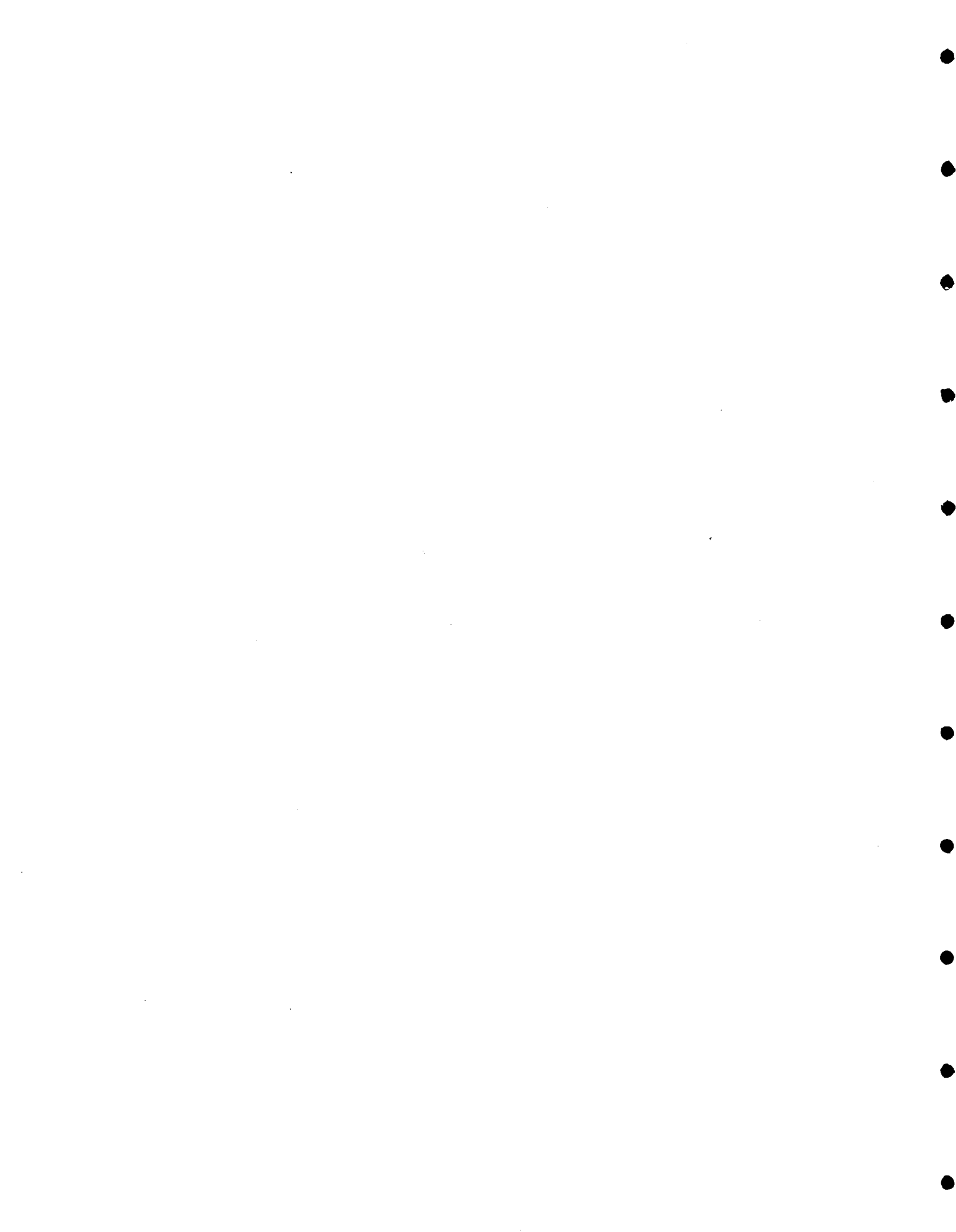

5.0 CONCLUDING REMARKS

The analysis performed in section 4 plus the component data collected from airline sources represent the significant operational characteristics of the model 747 primary flight control system (PFCS).

Contemporary flight control systems, such as those on the 747, use a cable and linkage connection between conventional pilot controls and powered actuators that provide control surface movement. The description of the controls identifies the redundancy used in the design: separate cable systems for control and trim, dual load paths in mechanisms and linkages, and four independent hydraulic power systems used in paired combinations for each control surface.

Advanced concepts using active control technology (ACT) may very well be different in terms of hardware. To evaluate the advantages of ACT, operating characteristics, such as reliability and maintenance cost of the existing hardware that may be affected, need to be assessed.

5.1 CONTROL FUNCTION RELIABILITY

The results of the reliability analysis clearly reflect the flight criticality of the primary control functions within the flight control system. To summarize these results, the failure probability for each control function for a typical 4-hr flight for a 747 is listed in table 46.

Table 46. Failure Probability of Each Control Function for a 4-hour Flight

Control function	Probability of failure during a 4-hr flight
Elevator	0.218×10^{-10}
Stabilizer trim	0.531×10^{-7}
Lateral (aileron and spoiler)	0.211×10^{-10}
Rudder	0.107×10^{-9}
Speed brakes	0.572×10^{-6}
PFCS (elevator, aileron and rudder)	0.132×10^{-9}

The failure probability results were obtained from CARSRA (computer-aided redundant system reliability analysis), a program previously developed for NASA to analyze fault-tolerant computer systems. Since CARSRA was designed to handle systems with several levels of redundancy, each level having identical sets of modules, it was not directly applicable to this type of analysis. However, the reliability modeling task for this analysis was arranged to be compatible with the program and satisfactory results were obtained. The results were verified by using another computer program. CARSRA was also designed to compute functional readiness, which is defined as the probability that a certain prescribed function is available after some time of system operation. For this study, the functional readiness of the speed brakes (0.999979) was

computed at the descent phase of a flight, which was specified at the 90% completion of a 4-hr flight. Functional readiness for the other systems was not computed for any flight phase because these systems operate full time.

The PFCS as a system was defined as the elevator, aileron, and rudder control functions. A reliability sensitivity study was made to determine the contribution of each of these control functions to the PFCS. Results show that the rudder control function contributed to 92% of the PFCS failure probability. This percentage is due to the higher failure probability of this function compared with the elevators and ailerons if the hydraulic power supply failures were excluded. The hydraulic power supply failure probability was a significant contributor to the failure probabilities of the elevator and aileron control functions, but not the rudder function.

5.2 MAINTENANCE COST ASSESSMENT

The maintenance cost for the PFCS is \$3.94 per flight-hour for unscheduled maintenance and an estimated \$0.19 per flight-hour for scheduled maintenance. The unscheduled maintenance cost is broken down in table 47. To put these figures in perspective, the direct maintenance costs of the mechanical flight control system (PFCS) and automatic flight control system (AFCS) electronics are about the same. However, the delay and cancellation costs for the PFCS are more than 10 times those for the AFCS because of the dispatch criticality of primary controls. The AFCS-related costs, adjusted to 1978 dollars, were obtained from the data supplied in the 747 flight control electronics reliability and maintenance study (NAS1-13654).

Table 47. Total PFCS Unscheduled Maintenance Cost

Unscheduled maintenance cost	\$/flight hour
Direct maintenance	
Line maintenance	0.21
Shop maintenance	2.20
Delay and cancellation	<u>1.53</u>
Total	3.94

6.0 REFERENCES

1. NASA CR-145024, Airborne Advanced Reconfigurable Computer System (ARCS), contract NAS1-13654, August 1976
2. Welker, E.L. and M. Lipow, "Estimating the exponential failure rate from data with no failure events," Proceedings of 1974 Annual Reliability and Maintainability Symposium
3. MIL-HDBK-217B, Military Standardization Handbook. Reliability Prediction of Electronic Equipment, September 1974
4. NASA CR-145271, Flight Control Electronics Reliability/Maintenance Study, contract NAS1-13654, December 1977

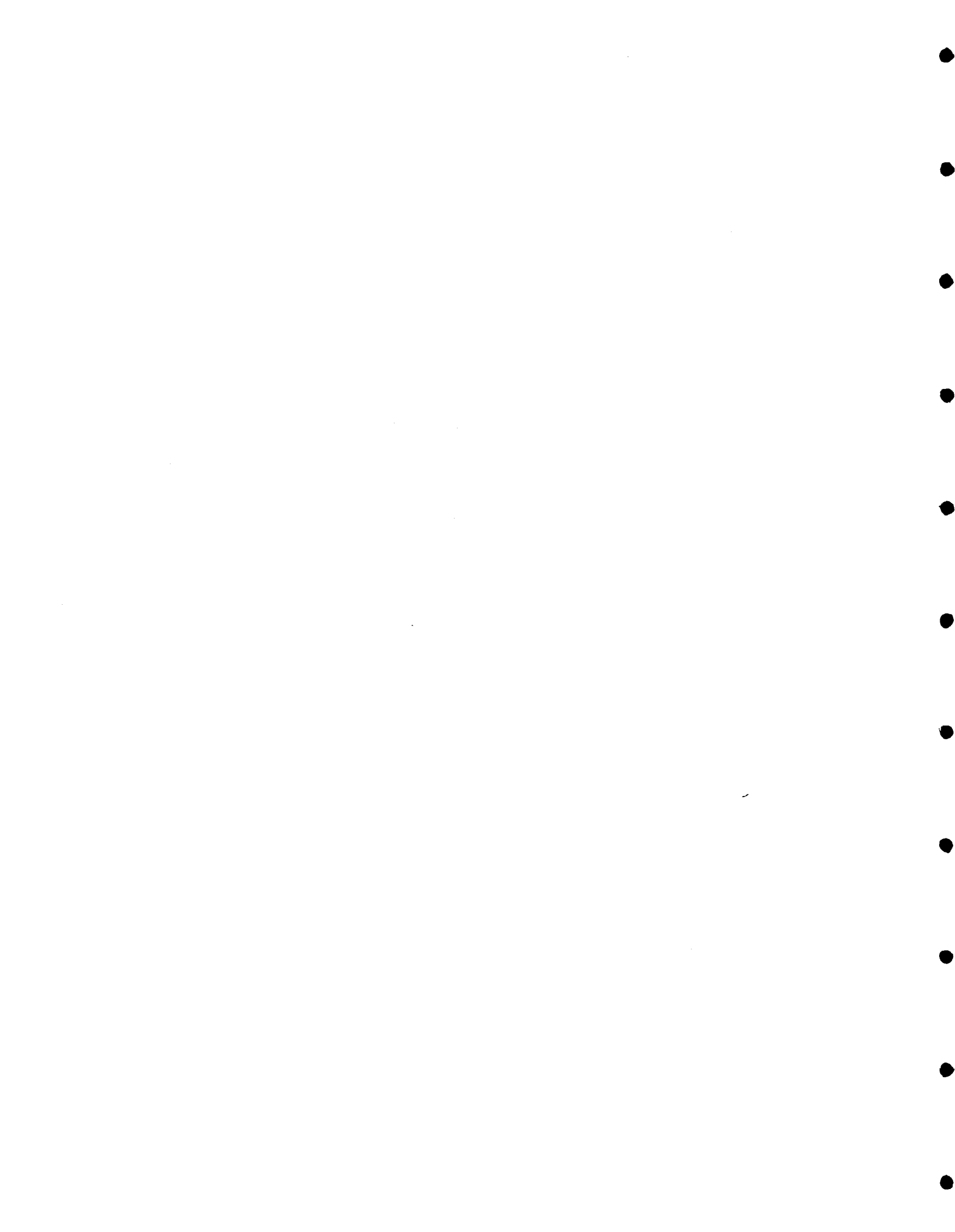

APPENDIX A

CARSRA PROGRAM DESCRIPTION AND USERS GUIDE

CARSRA is a FORTRAN program specifically developed during the ARCS contract (NAS1-13654) and the sections on the program description and the guide for setting up the input for the computer are included in this appendix.

CARSRA, A RELIABILITY ESTIMATION TOOL FOR REDUNDANT SYSTEMS

1. 0 PROGRAM DESCRIPTION

1. 1 Introduction

CARSRA (Computer Aided Redundant System Reliability Analysis) is a FORTRAN program which is designed to facilitate the reliability assessment task for fault tolerant reconfigurable systems. It is capable of taking into account influences from transient faults and will model a wide range of redundancy management strategies.

Many previously developed reliability estimation tools are based on success paths tabulation. Examples are the TASRA program developed by Battelle Columbus Laboratories (reference 1) and the ARMM program described in reference 2. One disadvantage of the success path tabulation approach is the very large number of success paths in a highly redundant system. Another perhaps more significant disadvantage with the above mentioned programs is their inability to model transient fault and failure coverage effects where the latter parameter reflects the probability of detecting, isolating and recovering from a failure.

Recently, see for example references 3 and 4, Markov modeling has been utilized to model the effect of failure coverage. The Markov model has the advantage of offering high flexibility which makes it possible to take into account most factors of interest including fault transients, failure coverage and the possibility of spares or maintenance actions. However, a basic disadvantage with the direct Markov model approach is the very large number of Markov states required to model a system with (many) internal signal consolidation (voting) nodes.

The most significant feature of the CARSRA program is the concept of partitioning the system into smaller entities, each of which may be treated by a Markov model of lower dimension. This preserves the Markov model flexibility, avoiding the problem of an exorbitant number of Markov states.

Another significant feature of CARSRA is the ability to assess Functional Readiness as well as system failure probability. The concept of Functional Readiness is of considerable significance for a mission containing a critical subtask which will either

be performed, or not performed, depending on the operational redundancy level at the time of demand. An example is an aircraft automatic landing function for which a certain level of hardware redundancy is required before a landing may be initialized in poor visibility weather conditions.

1.2 Definition of Terms

A number of special terms are defined which will be used in the following.

A module is the smallest functional entity treated by the program. It has a Poisson type failure distribution with an a priori known failure rate.

A stage is a set of identical redundant modules. Voting or Signal Consolidation is often performed on the output signals from the modules in a stage. There are however stages without output voting. TMR stands for Triple Modular Redundancy and is associated with majority voting on the module outputs of a stage such that at least two out of three modules have to operate for the stage to survive.

A channel is a particular minimal set of modules capable of performing the system function in a non-redundant configuration.

1.3 The CARSRA Approach

The system is conceptually partitioned into stages, for example each sensor type in a flight controls system will constitute a stage as will the processors and each servo function.

The operational status of each stage is modeled by a finite order Markov process in which each state corresponds to a particular redundancy state. An example is shown in Figure 1.

The transition rates λ_{ij} in the figure are assumed constant, i. e., not time varying and CARSRA will handle up to ten states per stage.

The operational status of a module in a particular stage may or may not depend on modules in other stages being operational. A module which when failed will cause loss of function of another module in a different stage will be called a "dependency" module and the corresponding stage a "dependency stage".

FIGURE 1 EXAMPLE OF STAGE MARKOV MODEL

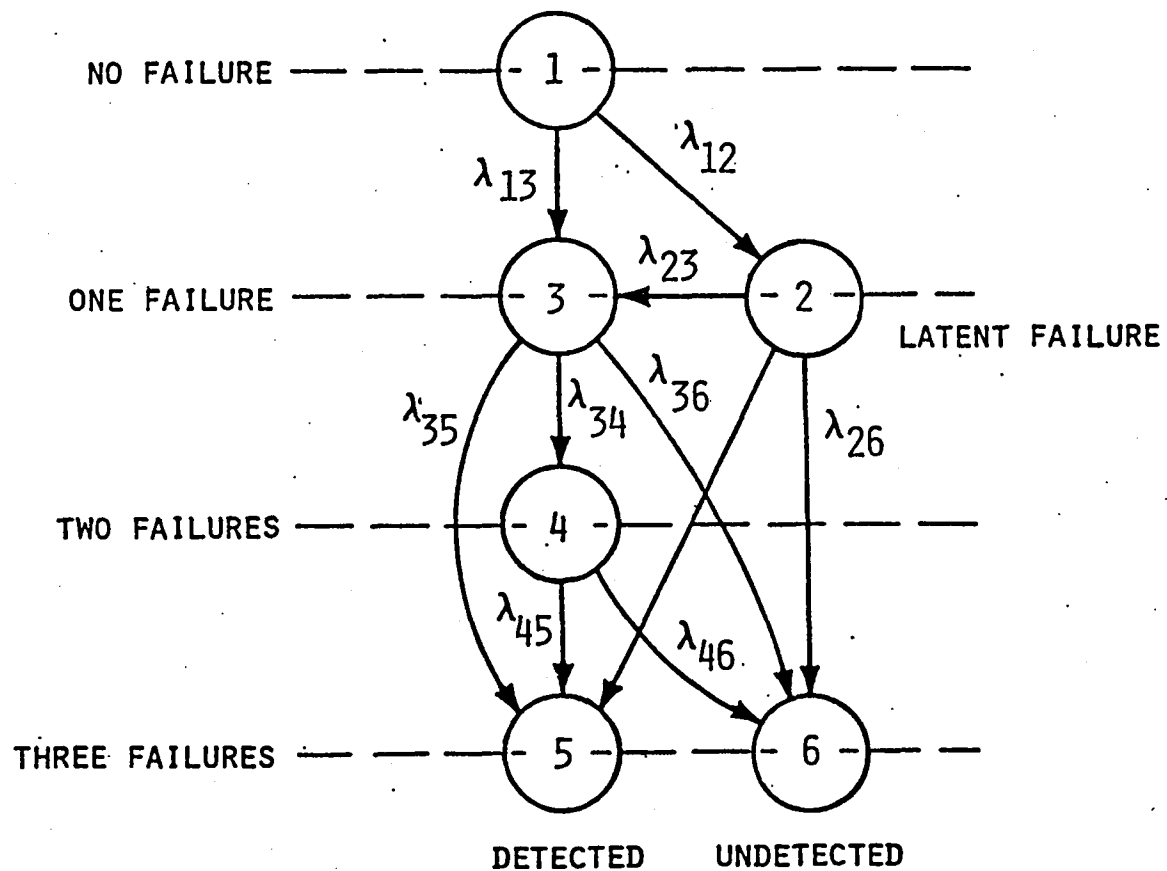

EXAMPLE = $\lambda_{34} = 2\lambda_P \mu_{34} + 2\lambda_T \ell_{34}$

μ = PERMANENT RATE RATIO

ℓ = LEAKAGE

1.3 (cont'd)

Thus, there are two types of stages: dependency and non-dependency stages. Some stages may be both dependency and non-dependency stages. The dependency structure of a system may be described by a dependency tree diagram, an example of which is displayed in Figure 2 for a flight controls system. In this system the processor/memory stage is a dependency stage, the MPX and A/D stage both dependency and a non-dependency stages and each sensor function a non-dependency stage.

The lines connecting the different stages indicate the dependency structure in the sense that a failure in for example the processor channel A will cause loss of function of the channel A sensor and servo modules. The digits at the upper right hand corner of each block indicate the number of redundant modules in each stage.

The signal consolidation, or voting nodes, to the right in the figure represents functions needed for system survival. A loss of a combination of these functions (for example all of them) will cause system failure. This combination may be specified by a particular entry to the program, a feature which will be further described shortly.

CARSRA treats dependency between stages by an approach which may be denoted "exhaustive conditioning." The essence of this approach is to make the non-dependency stages independent via conditioning upon the failure status of the dependency stages.

This approach is most easily explained by presenting a simple example. Consider the triplex system outlined in Figure 3 consisting of two sensor stages A and B, a multiplex stage C and a computer stage D. The sensor signals are multiplexed and cross strapped into the computers where signal selection (voting) and failure detection is performed in software.

TMR operation is assumed which implied that two out of three signals are required at each voting node. For simplicity the assumption is made that the output voter has zero failure rate.

FIGURE 2: FLIGHT CONTROL SYSTEM DEPENDENCY TREE

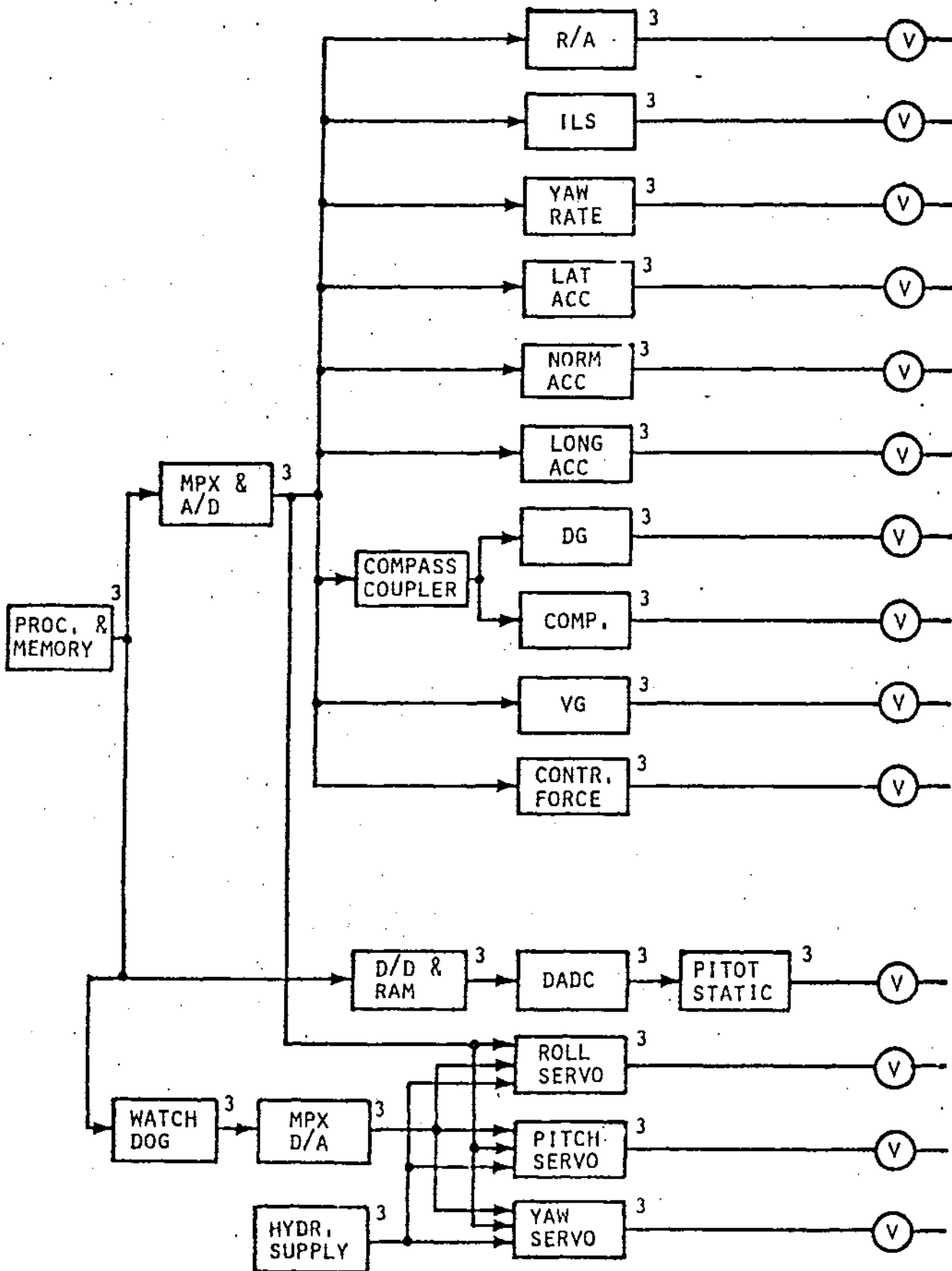

1.3 (cont'd)

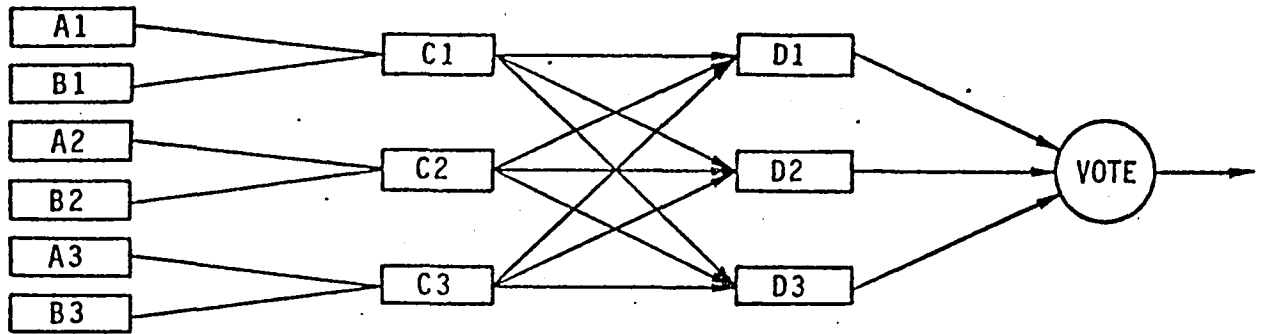

Figure 3

Note that the sensor stages and the multiplex stage are mutually dependent in the sense that a multiplex failure will cause a module failure both in sensor stage A and sensor stage B. The dependency is unidirectional since a sensor failure will not prevent the multiplex module from acquiring data from a sensor in another channel. Figure 4 displays the corresponding dependency tree.

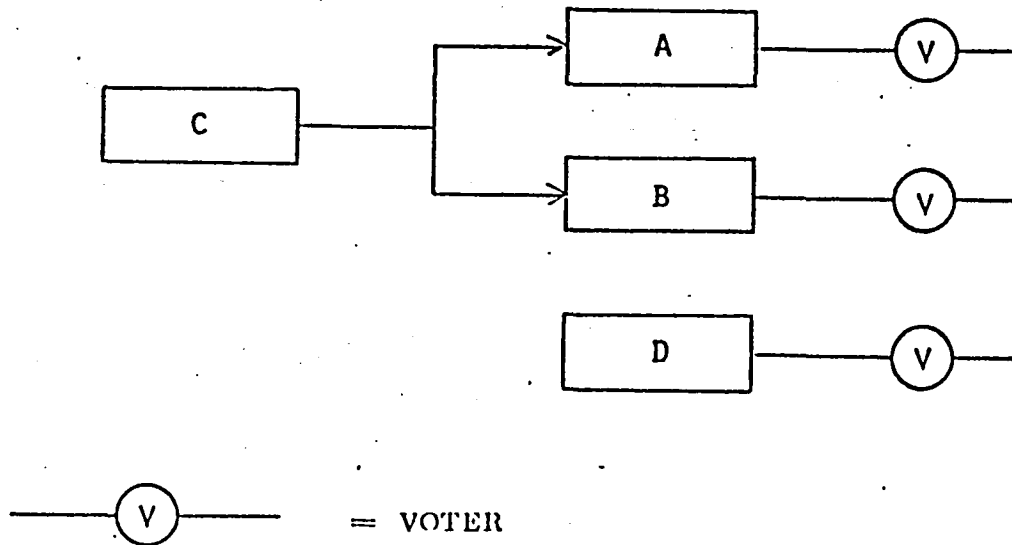

Figure 4

1.3 (cont'd)

To explain the approach, the following theorem will be needed:

Let E_i $i = 1, 2, \dots, n$ be disjoint events with $\sum_{i=1}^n P(E_i) = 1$.

Let F be an arbitrary event. Then,

$$P(F) = \sum_{i=1}^n P(F | E_i) \cdot P(E_i)$$

The success probability for the system of Figure 1 may now be found by defining the events E_i as follows:

- E_1 = no multiplex module failed
- E_2 = one multiplex module failed
- E_3 = two multiplex modules failed
- E_4 = all multiplex modules failed

The probability of system success may, according to the above theorem, be expanded:

$$P(S) = \sum_{i=1}^4 P(S | E_i) \cdot P(E_i)$$

The advantage of this representation is that the probabilities $P(S | E_i)$ usually are easier to find than finding $P(S)$ directly. For example:

$$P(S | E_1) = P \left\{ (\text{Stage A Survives}) \text{ and } (\text{Stage B Survives}) \text{ and } (\text{Stage D Survives}) \right\}$$

becomes with R = module reliability and $Q = 1-R$:

$$P(S | E_1) = (R_A^3 + 3R_A^2 Q_A) \cdot (R_B^3 + 3R_B^2 Q_B) \cdot (R_D^3 + 3R_D^2 Q_D)$$

Furthermore:

$$P(E_1) = R_C^3$$

1.3 (cont'd)

The next term in the expression contains the factor $P(S|E_2)$, i. e., the probability of system survival given that one multiplex module is failed. In this case both of the remaining modules in sensor stages A and B have to survive for system survival:

$$P(S|E_2) = R_A^2 \cdot R_B^2 \cdot (R_D^3 + 3R_D^2 Q_D)$$

$$P(E_2) = 3R_C^2 Q_C$$

Finally $P(S|E_3) = P(S|E_4) = 0$

Summarizing, the system reliability becomes:

$$P(S) = (R_A^3 + 3R_A^2 Q_A) (R_B^3 + 3R_B^2 Q_B) (R_D^3 + 3R_D^2 Q_D) R_C^3 +$$

$$+ R_A^2 \cdot R_B^2 (R_D^3 + 3R_D^2 Q_D) \cdot 3R_C^2 Q_C;$$

Note that this expression differs from what is obtained if the stages are assumed independent:

$$P(S_{IND}) = (R_A^3 + 3R_A^2 Q_A) (R_B^3 + 3R_B^2 Q_B) (R_C^3 + 3R_C^2 Q_C) \cdot$$

$$\cdot (R_D^3 + 3R_D^2 Q_D);$$

As was mentioned above, the voted (or signal consolidated) outputs from the non-dependency stages constitute the functions required for systems survival. There are, however, situations where these functions themselves may be redundant, for example the redundancy between aileron and spoiler control surfaces of certain aircrafts. CARSRA will model this situation by accepting a success event tabulation covering all, non-dependency stage combinations equivalent to system success.

Summarizing, the computation is performed in three different steps: Markov modeling for each stage, treating dependencies between stages via exhaustive conditioning and specifying the functions needed for success by success configuration tabulation.

1.4 The Functional Readiness Feature

Fault tolerant systems will continue to perform their functions even after experiencing one or several module failures. With this basic feature it will be of interest to be able to assess the probability of experiencing a certain redundancy degradation within a prescribed time interval and furthermore to be able to assess the system

failure probability given that a certain degradation has taken place. This information could be used to establish Functional Readiness Criteria, i. e., the system failure states that will not cause deferment of a particularly critical phase of a mission, for example the landing a manned spacecraft on the moon or the previously mentioned case of automatic landing of a passenger transport in low visibility weather conditions.

CARSRA accepts a selected Functional Readiness Criterion specifying the combination of modules which could be failed and computes the probability of having any of these modules failed as a function of time. It also computes the system failure given a Functional Readiness Criterion as a function of time in separately specified time frame. Two different system failure modes may be specified, e. g., detected or undetected system failure.

The following relations are used. Let $PFR(t_1)$, $i=1, 2, \dots, N$ denote the probabilities associated with the different specified Functional Readiness configurations at a time t_1 and let $PFP_i(t_2)$ be the conditional probability of a certain failure mode at an exposure time t_2 given Functional Readiness configuration i :

CARSRA then computes:

$$PFR = \text{Functional Readiness} = \sum_{i=1}^N PFR_i(t_1)$$

$$PFP = \text{Failure Probability} = \left[\sum_{i=1}^N PFP_i(t_2) \times PFR_i(t_1) \right] \cdot PFR^{-1}$$

In addition to the above mentioned features, two levels of computational accuracy may be specified. The resulting computational roundoff errors are indicated in the computer printout.

1.5 CARSRA Program Structure

In this section, the structure of the program will be described in enough detail to provide a basic understanding of the operation.

The program is designed using a top-down approach with each subtask carried out in a separate subroutine. The overall structure is shown in Figure 5.

MAIN is the main program and each of the other blocks represents subroutines with a higher order subroutine calling a lower order routine as indicated by the lines connecting the different blocks. The subroutine FAILPR will, for example, call the subroutine SETETY, STRIP, EQUAL, PRINTZ, INDFP and DEFP.

The operation of each of the subroutines and their interplay will next be described.

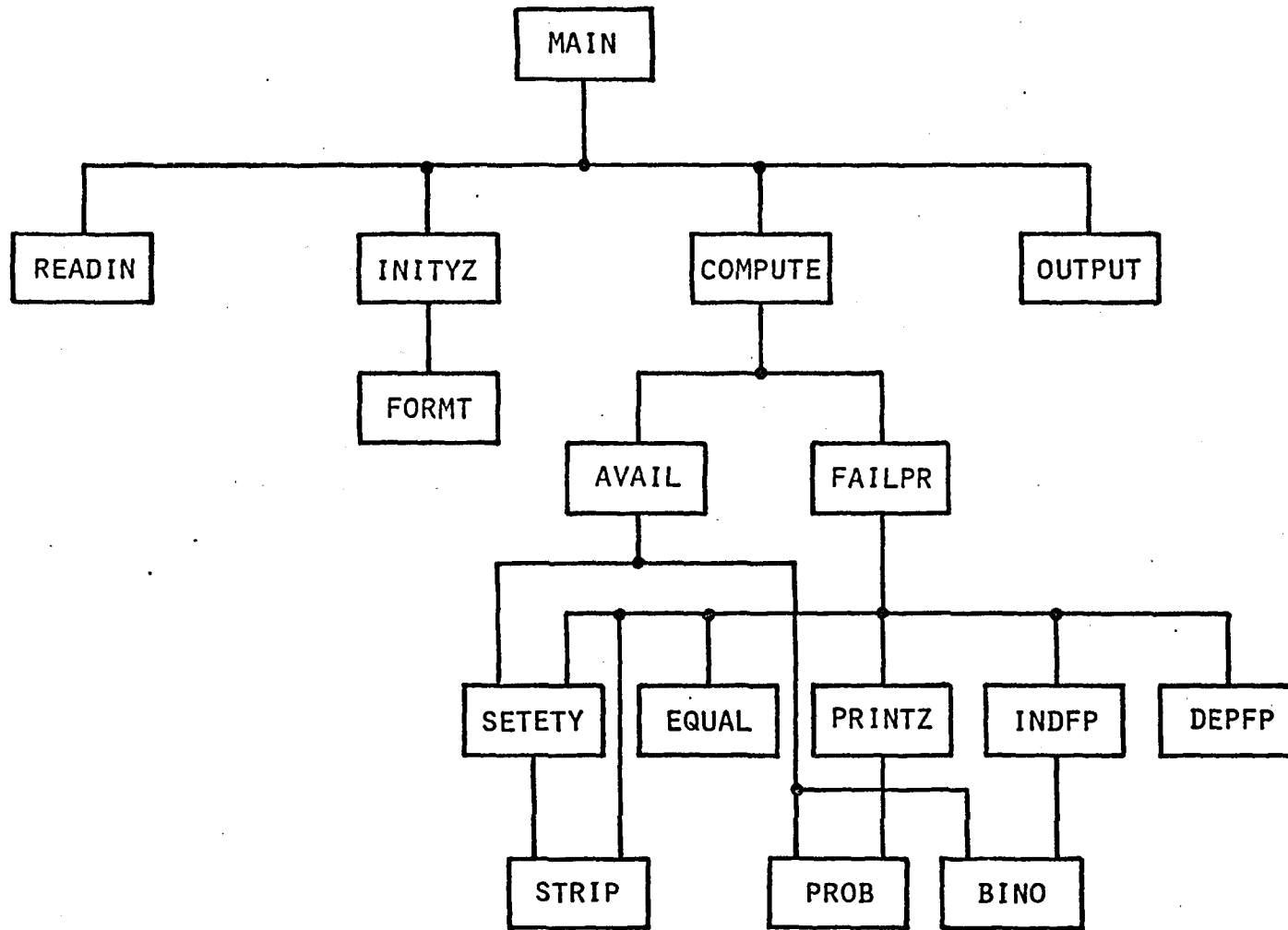

FIGURE 5: CARSRA STRUCTURE

1.5.1 Subroutine Descriptions and Flow Diagrams

MAIN: The MAIN program directs the data input, the computation, and the data printout. It calls the subroutine READIN, INITYZ, COMPUTE and OUTPUT. As part of the input data from READIN, the MAIN program gets the specified Functional Readiness time interval and time increment which it uses to set up a loop which computes Functional Readiness and system Failure Probability data and outputs this information for each Functional Readiness time increment. The MAIN flow diagram is shown in Figure 6.

READIN: Reads input data from a punched card file specifying Markov model transition rates, desired Functional Readiness time interval and increment, desired Failure Probability time interval and increment; Functional Readiness Criteria, the Success Configuration and the desired computational accuracy. The subroutine flow diagram is indicated in Figure 7.

INITYZ: Initializes the computation by computing the transition rates

$$\lambda_{ii} = - \sum_j \lambda_{ij}$$

It calls the subroutine FORMT which computes a matrix T and its inverse TINV used by the program to solve the Markov model equations. (The mathematical details may be found in the appendix.) The subroutine INITYZ also initializes the indicator array INDIC which is used to indicate the Functional Readiness Configuration, and the array INTMP which is used to map the dependency between modules. Also, the array MAP is constructed indicating the relation between modules failed in a stage and the number of the corresponding Markov state. The flow diagram is shown in Figure 8.

FORMT (I):

Computes the matrices T and TINV for a particular stage (see Appendix). I indicates the stage number. The flow diagram is displayed in Figure 9.

COMPUTE (AVT, AVBTY):

Computes the detected and undetected failure (or any other two selected failure mode) probabilities for a certain Functional Readiness time and criterion. The failure probabilities are stored in common arrays FAILP and FALUN where FAILP is the

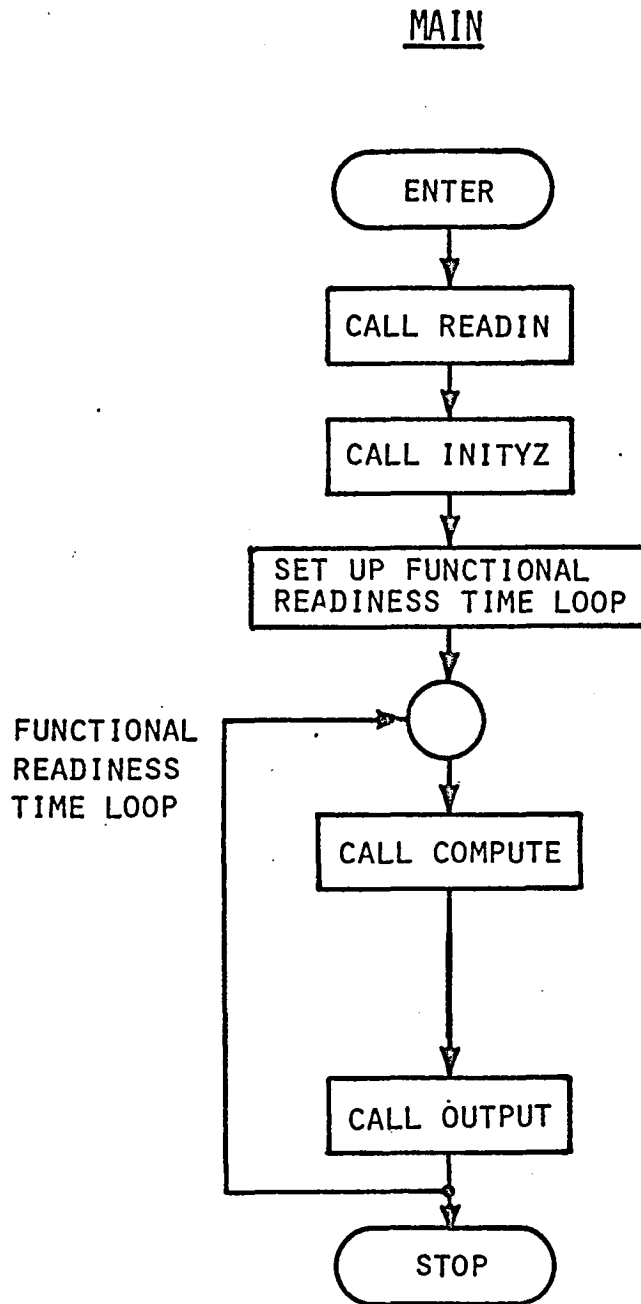

FIGURE 6: MAIN PROGRAM FLOW DIAGRAM

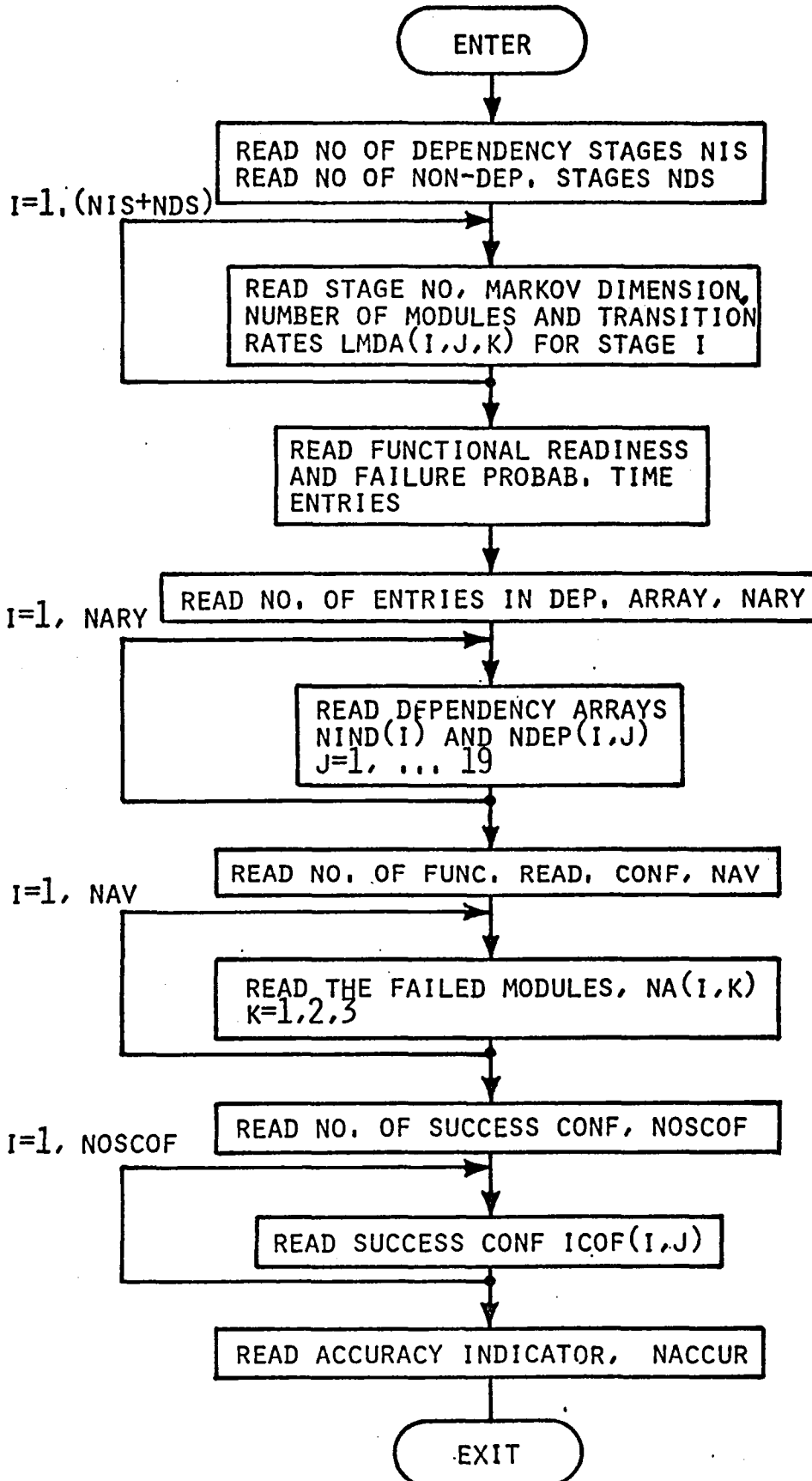

FIGURE 7: READIN FLOW DIAGRAM

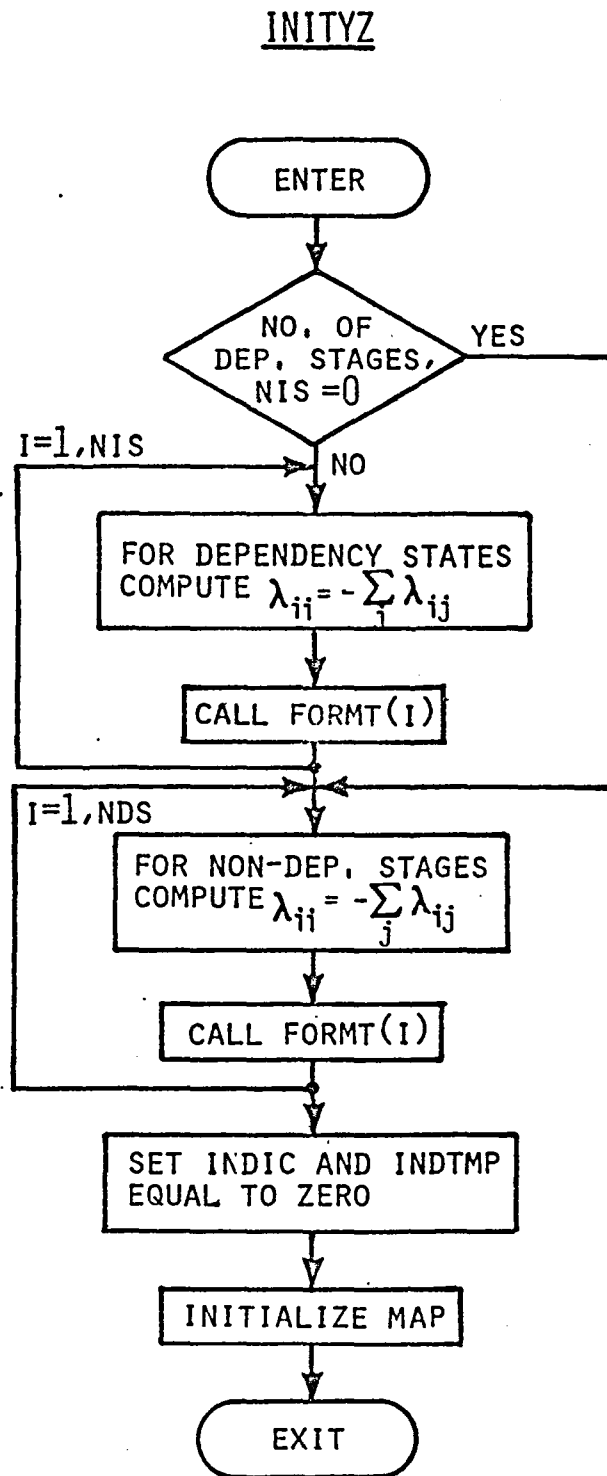

FIGURE 8: INITYZ FLOW DIAGRAM

FORMT

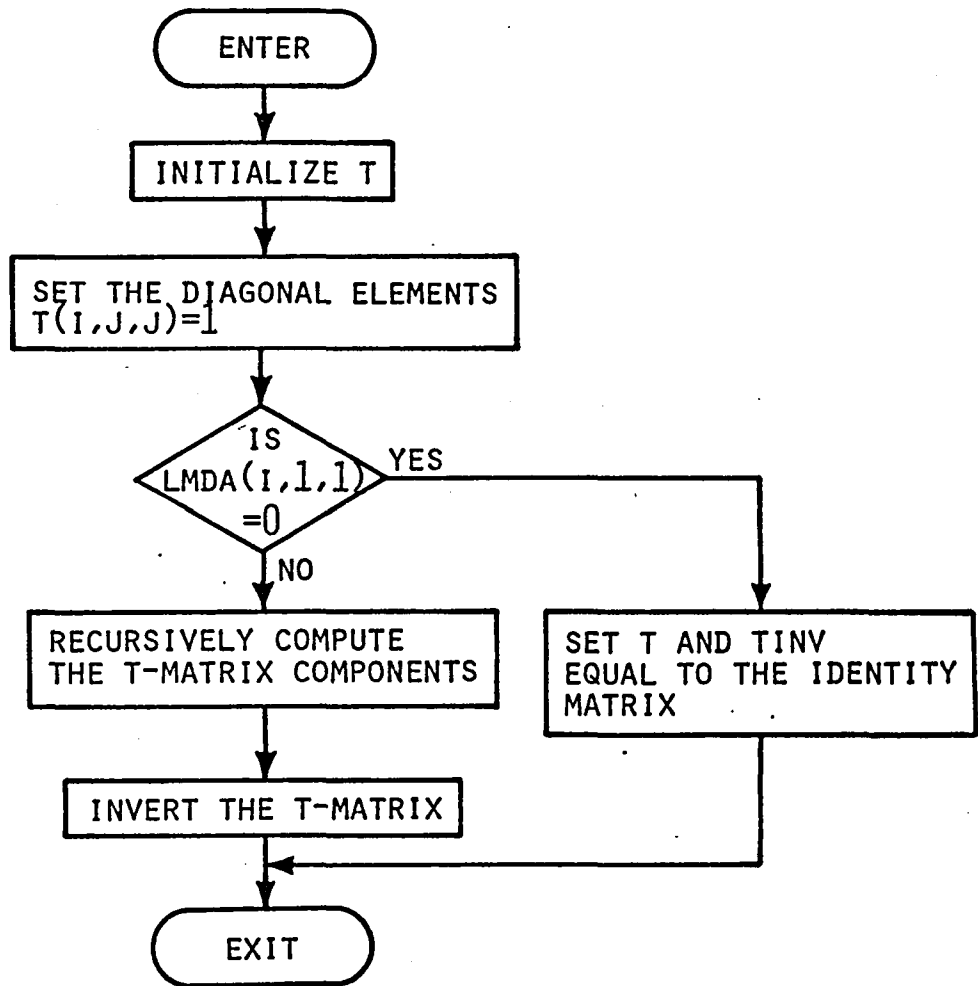

FIGURE 9: FORMT FLOW DIAGRAM

1.5.1 (cont'd)

probability of being in any of the two last Markov states in any stage and FALUN is the probability of being in the last Markov state in any stage. The array SPY which contains the computational truncation error estimates is also computed. The range of the above arrays are specified by the failure probability time range FPMT and the increment FPDT read by INITYZ, with the i element in each array corresponding to a failure probability time $T = i \cdot \text{FPDT}$. The Functional Readiness time is transferred from MAIN to COMPUTE in the argument AVT. COMPUTE calls the subroutine AVAIL to compute the Functional Readiness probability which is transferred to MAIN in the argument AVBTY. The flow diagram is shown in Figure 10.

OUTPUT (AVT, AVBTY):

Outputs the arrays FAILP, FALUN and SPY together with the Functional Readiness (AVBTY) for a particular Functional Readiness time (AVT).

AVAIL (PRO, I, TIME):

Computes the Functional Readiness, PRO, at time TIME for the Functional Readiness configuration specified by entry number I in the Functional Readiness table which is read by READIN and stored in the common array NA (I, K). The AVAIL subroutine also sets the indicator array INDIC corresponding to the Functional Readiness Configuration and, in the case the Functional Readiness configuration specifies a dependency module failure, rearranges the structure of the common arrays NIND and NDEP which specifies module dependencies. The corresponding rearranged arrays are NTIND and NTDEP.

The subroutine AVAIL uses the subroutine PROB to compute Functional Readiness and SETETY to set the indicator array INDIC. The flow diagram is shown in Figure 11.

COMPUTE

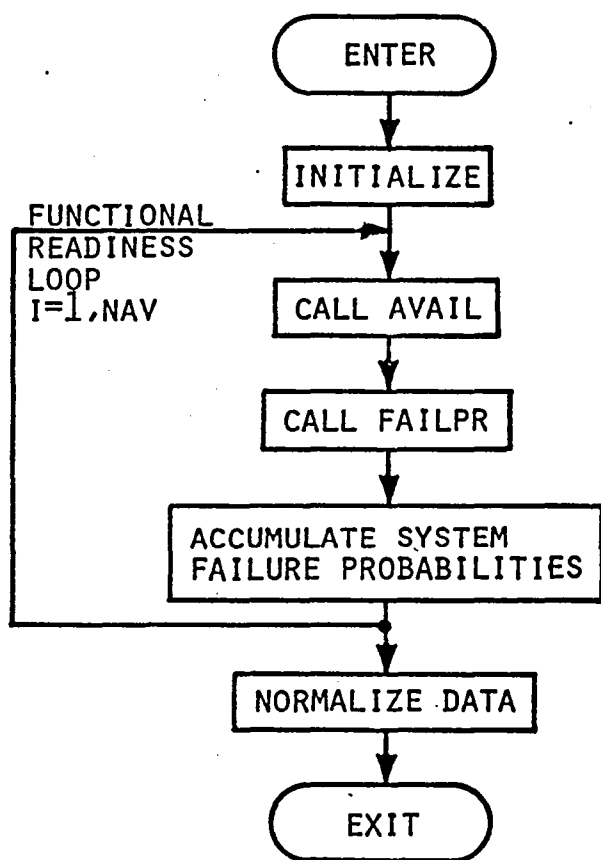

FIGURE 10: COMPUTE FLOW DIAGRAM

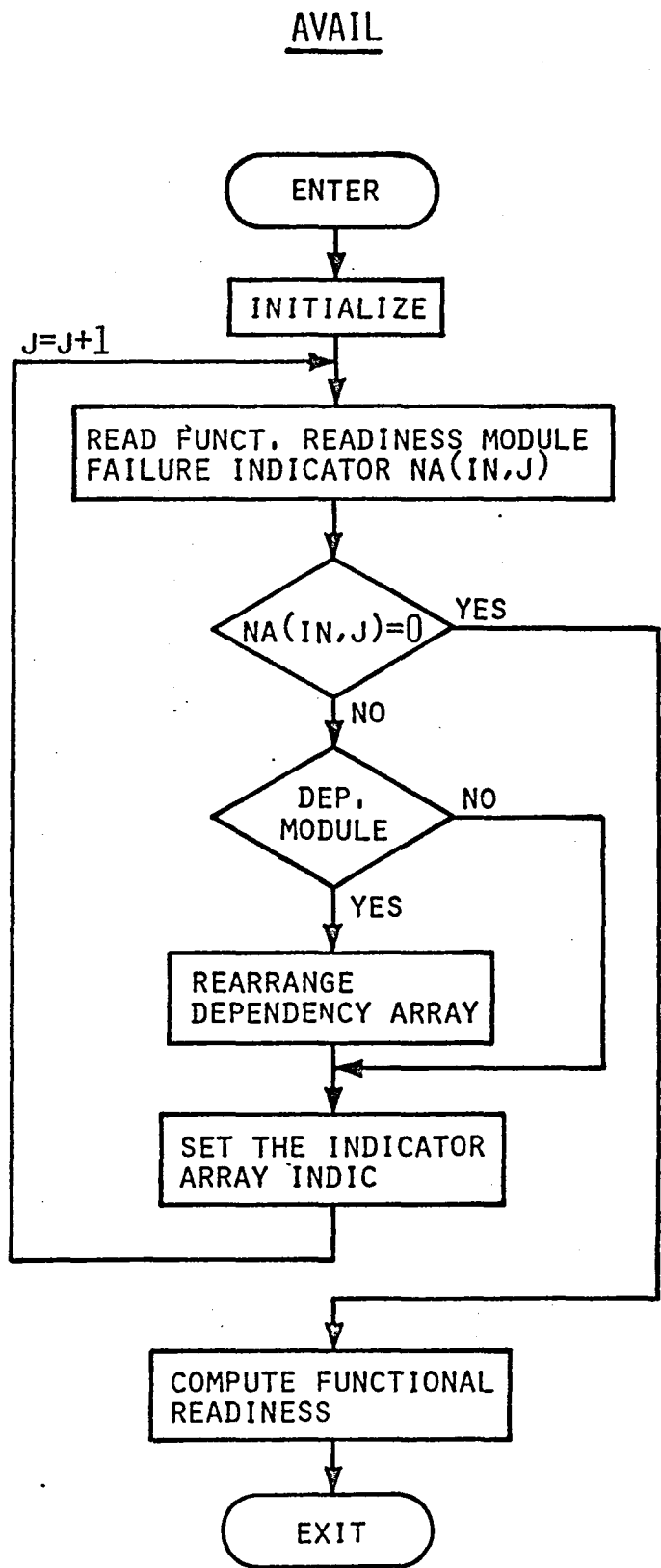

FIGURE 11: SUBROUTINE AVAIL FLOW DIAGRAM

PROB (ISTAGE, IENTRY, IEXIT, P, TIME):

This subroutine computes for stage ISTAGE, the probability P of being in Markov state IEXIT at time TIME given state IENTRY at time zero. The subroutine uses the previously, in FORMT, calculated matrices T and TINV.

SETETY (J):

The subroutine sets the failure condition array INDTMP according to the module failure pattern specified by entry number J in the dependency table which specified the system dependency structure. The flow diagram is shown in Figure 12.

STRIP (INPUT, NSTGE, NSTATE):

Finds the stage number XX and state Y from a three digit number INPUT = XXY.

FAILPR (FALP, FALND, SP):

This subroutine computes the failure probability arrays FAILP and FALUN for a certain Functional Readiness configuration specified by the status of the array INDIC which was set in AVAIL. It uses the (rearranged) dependency arrays NTIND (I) scanning through all entries I and failing combinations of dependency modules NTIND (I) which in turn causes non-dependency modules NTDEP (I, J), J = 1, 2, ... to fail. This is the actual implementation of the above described "exhaustive conditioning" approach. The probability of each combination of dependency module failure states is computed by calling the subroutine INDFP, and the conditional probability of the non-dependency modules failing, given the particular combination of dependency module failures, is computed by calling DEFP. The system failure probability is then computed by multiplying these two probabilities and summing over the different dependency module failure combinations. To avoid calling the subroutine PROB repeatedly all needed transition probabilities are computed initially by calling PRINTZ which stores those probabilities in the array PROBAB which is common for INDFP and DEFP.

Combinations of up to two different dependency module failures are considered if the accuracy indicator NACCUR entered by READIN is set to zero. With NACCUR = 1, combinations of up to three dependency module failures will be considered.

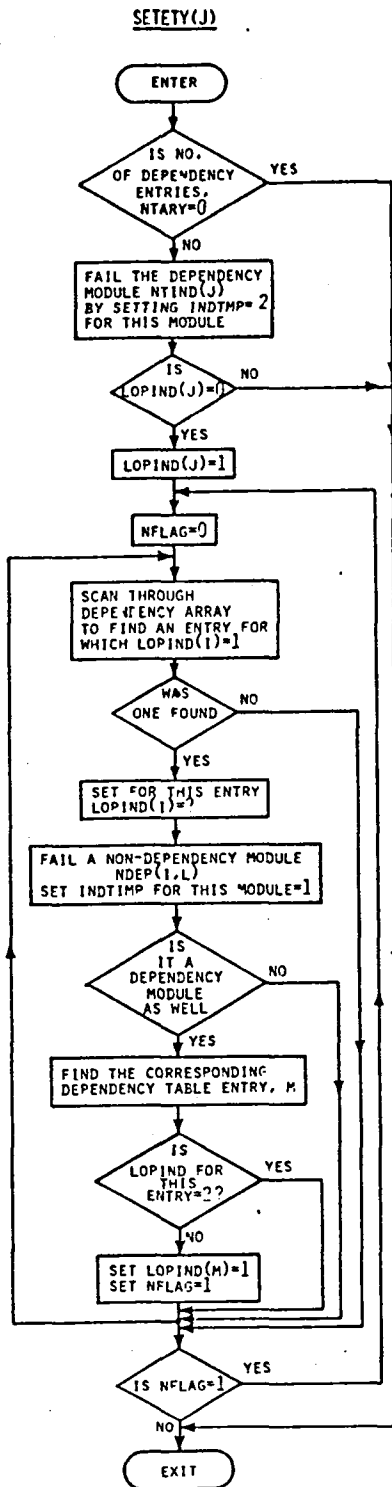

FIGURE 12: SUBROUTINE SETETY FLOW

1.5.1 (cont'd)

The truncation error, caused by not covering of possible combinations of dependency module failures, is the difference between unity and the sum of the probabilities of all considered dependency module combinations. A flow diagram over the subroutine FAILPR is outlined in Figure 13.

PRINTZ (TIME, NIS, NDS, DIM):

Computes Markov transition probabilities from state K to state J with $J \geq K$ for all system stages and stores the result in the array PROBAB.

EQUAL (A, B):

Equalizes the two dimensional array A with the two dimensional array B.

INDFP (PR, FP, FPU, K):

Computes the probability PR of a certain dependency module failure pattern specified by the state of the array INDTMP. The possibility that this specified combination leads to system failure is also computed and the two failure mode probabilities are stored in FP and FPU. The flow diagram is in Figure 14.

BINO (M, N, K):

Computes the binomial coefficient $K = \binom{M}{N}$

DEFP (PFAIL, PUNDET):

Computes the conditional probabilities of two system failure modes given a particular dependency module failure state which causes failure of non-dependency modules as specified by the status of the array INDTMP. It also scans through the stage success table and accumulates success probabilities over all combinations of non-dependency stages equivalent to system success. The flow diagram may be found in Figure 15.

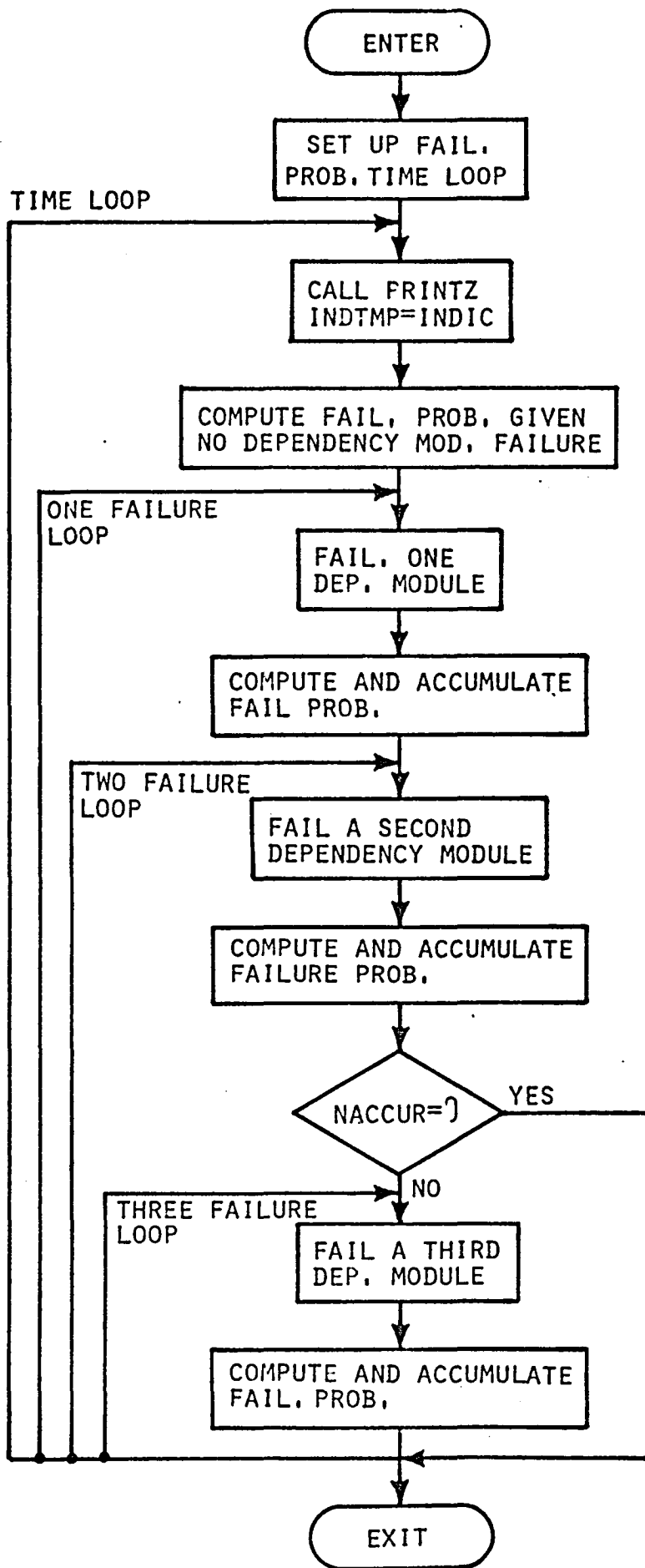

FIGURE 13
 FLOW DIAGRAM FOR
 SUBROUTINE FAILPR

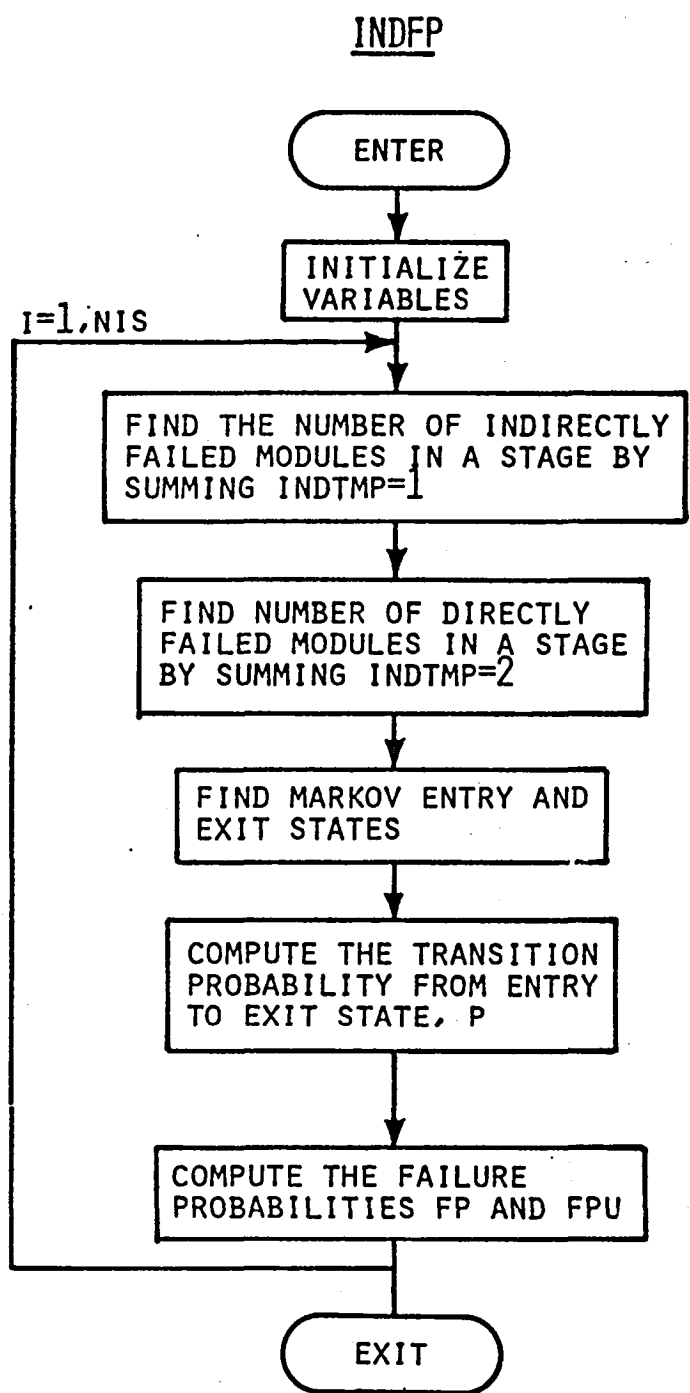

FIGURE 14: INDFP FLOW DIAGRAM

DEFPF

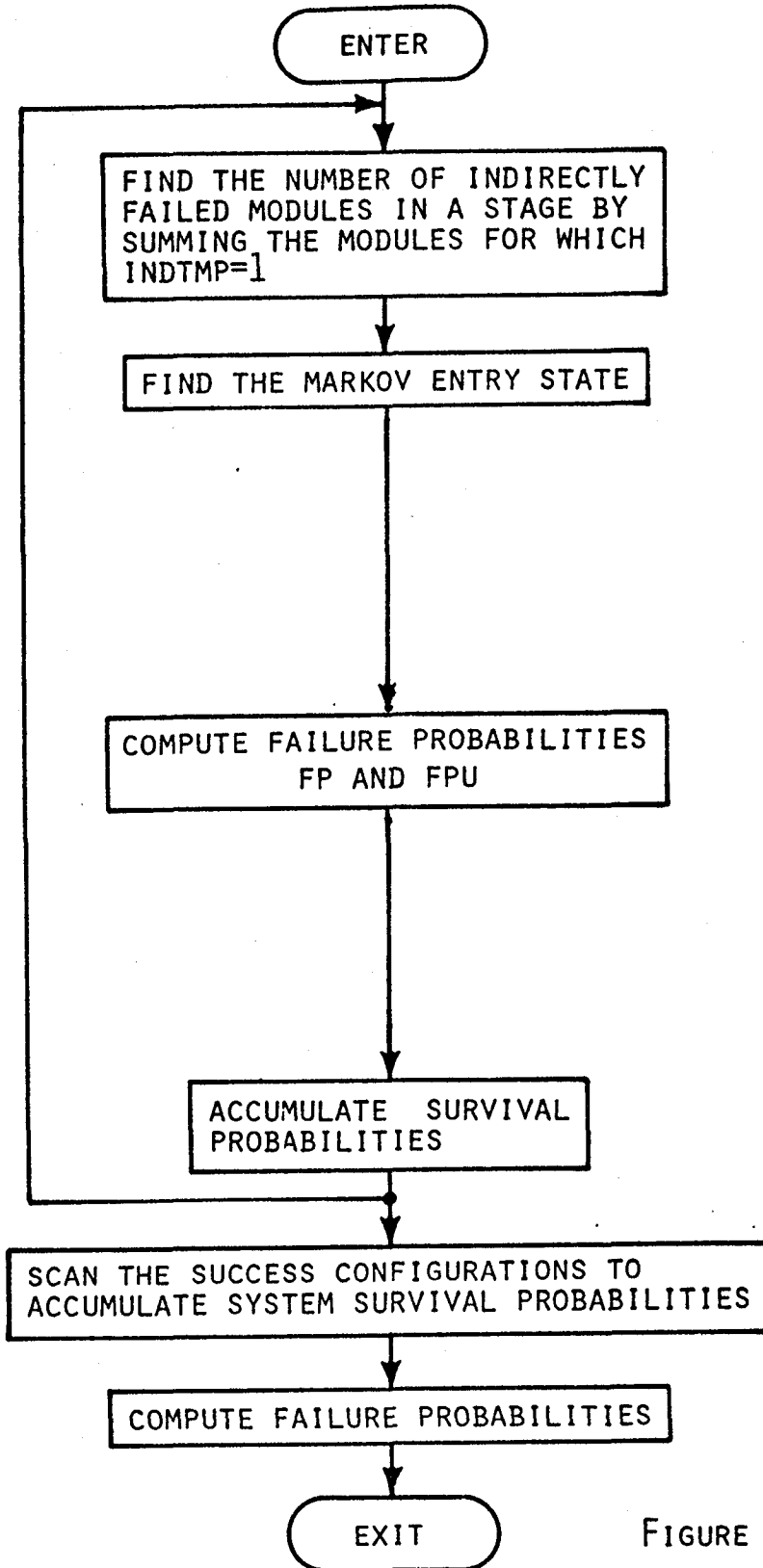

FIGURE 15: DEFPF FLOW DIAGRAM

2.0 CARSRA — A USER'S GUIDE

2.1 General

The CARSRA program is coded in FORTRAN IV with approximately 700 FORTRAN statements. It requires 100,000 core locations to run, and the execution time varies with the complexity of the system to be analyzed and the selected program option, the typical execution time being in the range of 1-30 seconds.

2.2 Input Description

All input data is on punched cards and must be input in a prescribed order. The following comments are made in relation to Table 1 which specifies required input data, the corresponding variable names used by the program, and the input format.

2.2.1 Dependency and Non-Dependency Stages

The system is partitioned into dependency and non-dependency stages with a failure of a dependency stage module causing failure of a module in a different stage. In cases where a stage both is a dependency and a non-dependency stage, it will, in the program input, be identified as a dependency stage.

Dependency stages are assigned numbers in the range 1-20 consecutively starting by 1. If failure of a certain dependency stage module causes another dependency stage module to fail, the former stage should be assigned a lower stage number than the latter. Dependency stage numbers should be assigned in consecutive order without leaving a number unassigned inside the array.

Non-dependency stages are assigned numbers in the range 21-50 consecutively starting with 21.

2.2.2 Stage Dimension, Numbers of Modules and Transition Rates

The assigned stage number (NST), the dimension (NDIM) and the number of modules in the stage (MODN) information is entered on one card. The dimension specifies the number of states in the Markov model for the stage and is used to control the read in of the following (NDIM-1) cards which

TABLE 1: CARSRA Input Data

Input Data	Variable Name	Format	No. of Cards
No. of non-dependency (NDS) and dependency stages (NIS)	NDS, NIS	2 I 10	1
Stage dimension and No. of modules for a certain stage, NST, followed by	NST, NDIM, MODN	3 I 10	1 } NDS+NIS TIMES NDIM-1
The corresponding transition rate matrix in failures per million hours.	LMDA (NST, K, J) J = 1, NDIM K = 1, (NDIM-1)	10(F8.2)	
Functional readiness and failure probability time entries	AMT, ADT, FPMT, FPDT	4(F10.5)	1
No. of dependency array entries	NARY	I 10	1
Dependency Structure	NIND(I), NDEP(I, J) I = 1, NARY J = 1, 19	20(I4)	NARY
No. of Functional Readiness Configurations	NAV	I 10	1
Failed Modules	NA (I, K) I = 1, NAV K = 1, 3	3(I4)	NAV
No. of Success Configurations	NOSCOF	I 10	1
Success Configurations	ICOF (I, J) I = NOSCOF J = 1, 50	50 I 1	NOSCOF
Accuracy Indicator	NACCUR	I 10	1

2.2.2 (cont'd)

specify the transition rates LMDA (NST, K, J) in failures per million hours. LMDA (NST, K, J) is the transition from state K to state J in stage NST with LMDA (NST, K, J), $J = 1, 2, \dots, \text{NDIM}$ on one card for each K value. Only (NDIM-1) cards corresponding to $K = 1, 2, \dots, (\text{NDIM}-1)$ have to be entered for each stage since the last state always will have zero transition rates. Only transitions from lower order to a higher order states are permitted, i. e., LMDA (NST, K, J) must be equal to zero (left blank) for $K > J$. This constraint implies that CARSRA as currently coded is unable to handle modeling of equipment repair.

Markov state one always models no module failures, Markov state two one module failure, and state three two module failures.

2.2.3 Functional Readiness and Failure Probability Time Entries

Transitional Readiness Time span (AMT) and time increment (ADT) are entered on one card together with Failure Probability Time span (FPMT) and time increment (FPDT). For each Functional Readiness Time equal to $I \times \text{ADT} \leq \text{AMT}$, $I = 0, 1, 2, \dots$, a table over the Failure Probabilities as a function of Failure Probability Time of $J \times \text{FPDT} < \text{FPM}$ $J = 1, 2, \dots$ is printed. If only the Failure Probabilities are of interest, enter $\text{AMT} = 0$, $\text{ADT} = 1$.

2.2.4 Dependency Array

The number of dependency modules in the system, (NARY), is entered on a separate card, followed by NARY cards specifying the system dependency configuration. Each dependency module NIND (I) ($I = 1, \dots, \text{NARY}$) will when failed cause failure of modules NDEP (I, J), $J = 1, \dots, N$ with $N \leq 19$. The modules are specified by NIND and NDEP in the form XXY with XX being the stage number and Y the module number within the stage. (See further the example below).

2.2.5 Functional Readiness Table

The number of Functional Readiness configuration entries NAV is specified on a separate card followed by NAV cards, one for each configuration. Each configuration is characterized by up to 3 failed modules NA (I, K) K = 1, 2, 3 where the module is indicated by XXY as before (2.2.4). The Functional Readiness probability computed by the program is the probability of having any one of the specified system failure patterns at a given time.

2.2.6 Stage Success Table

NOSCOF, entered on a separate card, specifies the number of stage failure patterns equivalent to system success. One card is thereafter entered for each pattern which is specified by a 1 (one) in a column corresponding to a failed stage. If all stages are essential for system success, NOSCOF is equal to one followed by a blank card. If two stages, for example the non-dependency stages 21 and 22, are redundant three cards are required:

1) Col 21 = 0 Col 22 = 0; 2) Col 21 = 1 Col 22 = 0; 3) Col 21 = 0 Col 22 = 1.

2.2.7 Accuracy Indicator

The accuracy indicator, NACCUR, specifies the level to which conditioning upon the combinations of dependency module failure is performed. If NACCUR = 0 (lower accuracy setting) all combinations of zero, one and two dependency module failures will be considered plus failure combinations equivalent to system failure. If NACCUR = 1, up to three dependency module failures will be considered plus failure combinations equivalent to system failure. The higher accuracy could be required when treating a system with high module redundancy (for example a quad system) or when the mission time is long. However, the program run time could be in the order of ten times longer for the higher accuracy setting.

The truncation error is indicated by an accuracy number. The correct failure probability value will lie in the range.

[printed output value, printed output value + accuracy] .

2.3

Output Description

A table over system failure probabilities are printed for each Functional Readiness Time $I \times ADT = AMT$. The table entries are Failure Probability times $J \times FPDT < FPMT$, the probabilities of a detected and an undetected system failure (or any other two failure modes), and the truncation error band.

REFERENCES

1. R. H. Blazek, R. E. Thomas, R. K. Thatcher and J. L. Easterday,
"TABular System Reliability Analysis", Battelle, Columbus Lab.
AFFDL-TR-71-128.
2. "An Automatic Reliability Mathematical Model", Boeing Document No. D6A-10500-1.
3. Y. W. Ng and A. Avizienis,
"A Unifying Reliability Model for Closed Fault Tolerant Systems"
1975 Int. Symp. on Fault Tolerance Computers, Paris June 18-20.
4. Jean-Claude Laprie
"Reliability and Availability of Repairable Structures"
1975 Int. Symp. on Fault Tolerance Computers, Paris, June 18-20.

1. The first part of the document discusses the importance of maintaining accurate records of all transactions. It emphasizes that proper record-keeping is essential for the integrity of the financial system and for the ability to detect and prevent fraud.

2. The second part of the document outlines the specific requirements for record-keeping, including the need to maintain original documents and to keep copies of all records for a minimum of seven years. It also discusses the importance of ensuring that records are accessible and retrievable at all times.

3. The third part of the document discusses the consequences of non-compliance with the record-keeping requirements. It states that failure to maintain accurate records can result in severe penalties, including fines and imprisonment. It also notes that non-compliance can damage the reputation of the individual or organization involved.

APPENDIX B

AIRLINE COMPONENT REMOVAL DETAILS

Failure rates for each of the flight control modules are required for the reliability analysis. To derive these rates, airline component removal histories are used. This appendix is a collection of several 747 operators reports giving details of unscheduled component removals on a yearly basis. The reports cover the years 1970 through 1976.

B-3

747 COMPONENT REMOVAL DATA

OP	YR	QPA	UNIT HOURS	NO. REM	RATE	% JUS	OP	YR	QPA	UNIT HOURS	NO. REM	RATE	% JUS	OP	YR	QPA	UNIT HOURS	NO. REM	RATE	% JUS
27-02-340-051							MODULE, FLIGHT CONTROL PSN INDC							P/N: 60800102						
A	70	1	55100	0	0.0		J	73	1	61540	21	0.3412		Z	73	1	20834	16	0.7680	
A	71	1	96878	1	0.0103		J	74	1	58440	18	0.3080		Z	74	1	31679	16	0.5051	
A	72	1	119846	3	0.0250		J	75	1	53618	16	0.2984		Z	75	1	40794	36	0.8825	
A	73	1	57296	2	0.0349		J	76	1	57230	28	0.4893	65	Z	76	1	46014	34	0.7389	
A	CUM		329120	6	0.0182		J	CUM		319116	111	0.3478		Z	CUM		139321	102	0.7321	
B	70	1	11882	4	0.3366		L	71	1	16466	2	0.1215		ZA	70	1	17055	1	0.0586	
B	71	1	60514	15	0.2479		L	73	1	41640	22	0.5283		ZA	71	1	63702	16	0.2512	
B	72	1	71613	24	0.3351		L	74	1	57674	16	0.2774		ZA	72	1	61523	29	0.4714	
B	73	1	63517	30	0.4723		L	75	1	71056	40	0.5629		ZA	73	1	59928	23	0.3838	
B	74	1	60612	42	0.6929		L	76	1	80937	50	0.6178		ZA	74	1	26583	10	0.3762	
B	75	1	49413	39	0.7893		L	CUM		267773	130	0.4855		ZA	75	1	26728	2	0.0748	
B	76	1	38378	43	1.1204		R	72	1	26816	12	0.4475		ZA	76	1	28259	5	0.1769	
B	CUM		355929	197	0.5535		R	73	1	27214	15	0.5512		ZA	CUM		283778	86	0.3031	
D	73	1	30887	23	0.7446		R	74	1	27531	10	0.3632		ZB	75	1	105138	17	0.1617	80
D	74	1	23604	1	0.0424		R	75	1	28841	6	0.2080		ZB	76	1	106947	28	0.2618	68
D	CUM		54491	24	0.4404		R	CUM		110402	43	0.3895		ZB	CUM		212085	45	0.2122	
H	70	1	5405	1	0.1850	100	S	71	1	6039	2	0.3312		ALL	70		96090	6	0.0624	
H	71	1	17065	5	0.2930	50	S	73	1	9189	0	0.0		ALL	71		297840	54	0.1813	
H	72	1	32366	12	0.3708	90	S	74	1	9025	2	0.2216		ALL	72		368344	101	0.2742	
H	73	1	43607	23	0.5274		S	CUM		24253	4	0.1649		ALL	73		424201	177	0.4173	
H	74	1	57550	25	0.4344		T	71	1	3385	0	0.0		ALL	74		360191	142	0.3942	
H	CUM		155993	66	0.4231		T	72	1	8331	6	0.7202		ALL	75		375588	156	0.4153	
J	70	1	6648	0	0.0		T	73	1	8549	2	0.2339		ALL	76		357765	188	0.5255	
J	71	1	33791	13	0.3847		T	74	1	7493	2	0.2669		ALL	CUM		2280019	824	0.3614	72
J	72	1	47849	15	0.3135		T	CUM		27758	10	0.3603								
27-02-576-811							VALVE, AIL/SPLR/CLCP HYD S/D							P/N: 60800258						
B	70	4	47528	0	0.0		J	70	6	39888	0	0.0		Z	73	8	166672	2	0.0120	
B	71	4	242056	2	0.0083		J	71	6	202746	1	0.0049		Z	74	8	253432	2	0.0079	
B	72	4	286452	4	0.0140		J	72	6	287094	0	0.0		Z	CUM		481128	4	0.0083	
B	73	12	762204	8	0.0105		J	73	6	369240	3	0.0081		ZA	70	4	68220	1	0.0147	
B	74	12	727344	4	0.0055		J	74	6	350640	4	0.0114		ZA	71	4	254808	0	0.0	
B	CUM		2065584	18	0.0087		J	CUM		1249608	8	0.0064		ZA	72	4	246092	3	0.0122	
D	73	8	247096	1	0.0040		L	71	4	65864	0	0.0		ZA	73	4	239712	2	0.0083	
D	74	8	188832	3	0.0159		L	73	8	333120	2	0.0060		ZA	74	4	106332	1	0.0094	
D	CUM		435928	4	0.0092		L	74	8	461392	0	0.0		ZA	CUM		915164	7	0.0076	
H	70	8	43240	0	0.0		L	CUM		860376	2	0.0023		ALL	70		198876	1	0.0050	
H	71	8	136520	1	0.0073		R	73	9	244926	0	0.0		ALL	71		909242	4	0.0044	
H	72	8	258528	3	0.0116	100	R	74	9	247779	0	0.0		ALL	72		1132342	10	0.0088	
H	73	8	348856	2	0.0057		R	CUM		492705	0	0.0		ALL	73		2711826	20	0.0074	
H	74	8	460400	2	0.0043		Z	71	4	7248	0	0.0		ALL	74		2796151	16	0.0057	
H	CUM		1247544	8	0.0064		Z	72	4	53776	0	0.0		ALL	CUM		7748437	51	0.0066	100

747 COMPONENT REMOVAL DATA

OP	YR	OPA	UNIT HOURS	NO. REM	RATE	% JUS	OP	YR	OPA	UNIT HOURS	NO. REM	RATE	% JUS	OP	YR	OPA	UNIT HOURS	NO. REM	RATE	% JUS
27-02-675-131 CON/U, CNTRL LTRL HYD (CLCP/CCA)							P/N: 60800052													
A	70	2	110200	2	0.0181		J	75	2	107236	1	0.0093		ZA	70	2	34110	0	0.0	
A	71	2	193756	4	0.0206		J	76	2	114460	1	0.0087		ZA	71	2	127404	8	0.0628	
A	72	2	239692	5	0.0209		J	CUM		638232	7	0.0110		ZA	72	2	123046	3	0.0244	
A	73	2	114592	0	0.0		L	71	2	32932	0	0.0		ZA	73	2	119856	3	0.0250	
A	CUM		658240	11	0.0167		L	73	2	83280	0	0.0		ZA	74	2	53166	0	0.0	
B	70	2	23764	0	0.0		L	74	2	115348	2	0.0173		ZA	75	2	53456	0	0.0	
B	71	2	121028	1	0.0083		L	75	2	142112	11	0.0774		ZA	76	2	56518	2	0.0354	
B	72	2	143226	0	0.0		L	76	2	161874	21	0.1297		ZA	CUM		567556	16	0.0282	
B	73	2	127034	2	0.0157		L	CUM		535546	34	0.0635		ZB	70	2	48036	0	0.0	
B	74	2	121224	4	0.0330		R	71	2	21022	0	0.0		ZB	71	2	97866	2	0.0204	
B	75	2	98826	4	0.0405		R	72	2	53632	1	0.0186		ZB	72	2	162366	6	0.0370	
B	76	2	76756	5	0.0651		R	73	2	54428	1	0.0184		ZB	74	2	214386	7	0.0327	
B	CUM		711858	16	0.0225		R	74	2	55062	1	0.0182		ZB	75	2	210276	19	0.0904	40
D	73	2	61774	1	0.0162		R	75	2	57682	1	0.0173		ZB	76	2	213894	23	0.1075	78
D	CUM		61774	1	0.0162		R	CUM		241826	4	0.0165		ZB	CUM		946844	57	0.0602	
H	70	2	10810	0	0.0		S	71	2	12078	0	0.0		ZD	76	2	93912	1	0.0106	
H	71	2	34130	1	0.0293		S	CUM		12078	0	0.0		ZD	CUM		93912	1	0.0106	
H	72	2	64732	2	0.0309		T	73	2	17098	1	0.0585		ALL	70		240216	2	0.0083	
H	73	2	87214	1	0.0115		T	74	2	14986	1	0.0667		ALL	71		711442	16	0.0225	
H	74	2	115100	0	0.0		T	CUM		32084	2	0.0623		ALL	72		909280	19	0.0209	
H	75	2	151280	0	0.0		Z	71	2	3624	0	0.0		ALL	73		830024	10	0.0120	
H	CUM		463266	4	0.0086		Z	72	2	26888	1	0.0372		ALL	74		869510	19	0.0219	
J	70	2	13296	0	0.0		Z	73	2	41668	1	0.0240		ALL	75		902456	37	0.0410	
J	71	2	67582	0	0.0		Z	74	2	63358	0	0.0		ALL	76		809442	55	0.0679	
J	72	2	95698	1	0.0104		Z	75	2	81588	1	0.0123		ALL	CUM		5272370	158	0.0300	61
J	73	2	123080	0	0.0		Z	76	2	92028	2	0.0217								
J	74	2	116880	4	0.0342		Z	CUM		309154	5	0.0162								
27-11-008-321 ACTUATOR, AIL TRIM CONTROL							P/N: SDL 1020M159													
A	70	1	55100	2	0.0363		D	CUM		54491	1	0.0184		L	CUM		115780	3	0.0259	
A	71	1	96878	1	0.0103		H	70	1	5405	0	0.0		R	73	1	27214	1	0.0367	
A	72	1	119846	3	0.0250		H	71	1	17065	0	0.0		R	74	1	27531	0	0.0	
A	73	1	57296	1	0.0175		H	72	1	32366	0	0.0		R	CUM		54745	1	0.0183	
A	CUM		329120	7	0.0213		H	73	1	43607	2	0.0459		Z	73	1	20834	0	0.0	
B	70	1	11882	0	0.0		H	74	1	57550	0	0.0		Z	74	1	31679	0	0.0	
B	71	1	60514	0	0.0		H	CUM		155993	2	0.0128		Z	CUM		52513	0	0.0	
B	72	1	71613	1	0.0140		J	73	1	61540	0	0.0		ALL	70		72387	2	0.0276	
B	73	1	63517	0	0.0		J	74	1	58440	0	0.0		ALL	71		190923	1	0.0052	
B	74	1	60612	0	0.0		J	CUM		115980	0	0.0		ALL	72		223825	4	0.0179	
B	CUM		268138	1	0.0037		L	71	1	16466	0	0.0		ALL	73		346535	5	0.0144	
D	73	1	30887	1	0.0324		L	73	1	41640	0	0.0		ALL	74		317090	3	0.0095	
D	74	1	23604	0	0.0		L	74	1	57674	3	0.0520		ALL	CUM		1150760	15	0.0130	

747 COMPONENT REMOVAL DATA

OP	YR	OPA	UNIT HOURS	NO. REM	RATE	%	JUS	OP	YR	OPA	UNIT HOURS	NO. REM	RATE	%	JUS	OP	YR	OPA	UNIT HOURS	NO. REM	RATE	%	JUS
27-11-008-361 ACTUATOR, AILERON LOCKOUT								P/N: 60880050-1															
A	70	2	110200	1	0.0091			H	CUM		311986	5	0.0160			Z	73	2	41668	0	0.0		
A	71	2	193756	0	0.0			J	70	2	13290	0	0.0			Z	74	2	63358	0	0.0		
A	72	2	239692	1	0.0042			J	71	2	67582	2	0.0296			Z	CUM		135538	1	0.0074		
A	73	2	114592	1	0.0087			J	72	2	95698	1	0.0104			ZA	70	2	34110	1	0.0293		
A	CUM		658240	3	0.0046			J	73	2	123080	1	0.0081			ZA	71	2	127404	2	0.0157		
B	70	2	23764	0	0.0			J	74	2	116880	1	0.0086			ZA	72	2	123046	0	0.0		
B	71	2	121028	1	0.0083			J	CUM		416536	5	0.0120			ZA	73	2	119856	3	0.0250		
B	72	2	143226	0	0.0			L	71	2	32932	0	0.0			ZA	74	2	53166	1	0.0188		
B	73	2	127034	0	0.0			L	73	2	83280	0	0.0			ZA	CUM		457582	7	0.0153		
B	74	2	121224	0	0.0			L	74	2	115348	0	0.0			ALL	70		192180	2	0.0104		
B	CUM		536276	1	0.0019			L	CUM		231560	0	0.0			ALL	71		580456	6	0.0103		
H	70	2	10810	0	0.0			R	73	2	54428	0	0.0			ALL	72		693282	5	0.0072		
H	71	2	34130	1	0.0293			R	74	2	55062	1	0.0182			ALL	73		751152	6	0.0080		
H	72	2	64732	2	0.0309			R	CUM		109490	1	0.0091			ALL	74		640138	4	0.0062		
H	73	2	87214	1	0.0115			Z	71	2	3624	0	0.0			ALL	CUM		2857208	23	0.0080		
H	74	2	115100	1	0.0087			Z	72	2	26688	1	0.0372										
27-11-248-011 GEARBOX, OUTBD AILERON LOCKOUT								P/N: 65880934															
A	70	2	110200	0	0.0			B	71	2	121028	0	0.0			ALL	71		314784	1	0.0032		
A	71	2	193756	1	0.0052			B	72	2	143226	0	0.0			ALL	72		382918	1	0.0026		
A	72	2	239692	1	0.0042			B	73	2	127034	0	0.0			ALL	73		241626	0	0.0		
A	73	2	114592	0	0.0			B	74	2	121224	0	0.0			ALL	74		121224	0	0.0		
A	CUM		658240	2	0.0030			B	CUM		536276	0	0.0			ALL	CUM		1194516	2	0.0017		
B	70	2	23764	0	0.0			ALL	70		133964	0	0.0										
27-11-325-061 LIMITER, AIL CONTROL LOAD								P/N: 65880314															
B	70	1	11882	0	0.0			J	CUM		208268	0	0.0			ZA	70	1	17055	0	0.0		
B	71	1	60514	0	0.0			L	71	1	16466	0	0.0			ZA	71	1	63702	0	0.0		
B	72	1	71613	0	0.0			L	73	1	41640	0	0.0			ZA	72	1	61523	0	0.0		
B	73	1	63517	0	0.0			L	74	1	57674	0	0.0			ZA	CUM		142280	0	0.0		
B	74	1	60612	0	0.0			L	CUM		115780	0	0.0			ALL	70		35585	0	0.0		
B	CUM		268138	0	0.0			R	73	1	27214	0	0.0			ALL	71		174473	0	0.0		
J	70	1	6648	0	0.0			R	74	1	27531	0	0.0			ALL	72		180985	0	0.0		
J	71	1	33791	0	0.0			R	CUM		54745	0	0.0			ALL	73		214745	0	0.0		
J	72	1	47849	0	0.0			Z	73	1	20834	0	0.0			ALL	74		235936	0	0.0		
J	73	1	61540	0	0.0			Z	74	1	31679	0	0.0			ALL	CUM		841724	0	0.0		
J	74	1	58440	0	0.0			Z	CUM		52513	0	0.0										
27-11-396-011 PROGRAMMER, AILERON								P/N: 6580554															
A	70	2	110200	0	0.0			J	72	2	95698	0	0.0			Z	73	2	41668	0	0.0		
A	71	2	193756	0	0.0			J	73	2	123080	0	0.0			Z	74	2	63358	0	0.0		
A	72	2	239692	0	0.0			J	74	2	116880	0	0.0			Z	CUM		135538	0	0.0		

(CONTINUED ON NEXT PAGE)

B-6

747 COMPONENT REMOVAL DATA																							
OP	YR	QPA	UNIT HOURS	NO. REM	RATE	% JJS	OP	YR	QPA	UNIT HOURS	NO. REM	RATE	% JUS	OP	YR	QPA	UNIT HOURS	NO. REM	RATE	% JUS			
27-11-396-011			PROGRAMMER, AILERON					(CONTINUED)			P/N: 6580554												
A	73	2	114592	0	0.0		J	CUM		416536	0	0.0		ZA	70	2	34110	0	0.0				
A	CUM		658240	0	0.0		L	71	2	32932	0	0.0		ZA	71	2	127404	0	0.0				
B	70	2	23764	0	0.0		L	73	2	83280	0	0.0		ZA	72	2	123046	0	0.0				
B	71	2	121028	0	0.0		L	74	2	115348	1	0.0087		ZA	CUM		284560	0	0.0				
B	72	2	143226	0	0.0		L	CUM		231560	1	0.0043		ALL	70		181370	0	0.0				
B	73	2	127034	0	0.0		R	73	2	54428	0	0.0		ALL	71		546326	0	0.0				
B	74	2	121224	0	0.0		R	74	2	55062	0	0.0		ALL	72		628550	0	0.0				
B	CUM		536276	0	0.0		R	CUM		109490	0	0.0		ALL	73		544082	0	0.0				
J	70	2	13296	0	0.0		Z	71	2	3624	0	0.0		ALL	74		471872	1	0.0021				
J	71	2	67582	0	0.0		Z	72	2	26888	0	0.0		ALL	CUM		2372200	1	0.0004				
27-11-598-031			WHEEL, AIL CONT								P/N: SEE 27-00-122-021												
27-11-675-0111			CONTROL UNIT, AIL POWER (IN8D)								P/N: 60800050-1												
A	70	2	110200	0	0.0		J	74	2	116880	0	0.0		ZA	70	2	34110	0	0.0				
A	71	2	193756	1	0.0052		J	75	2	107236	1	0.0093		ZA	71	2	127404	2	0.0157				
A	72	2	239692	1	0.0042		J	76	2	114460	2	0.0175		ZA	72	2	123046	1	0.0081				
A	73	2	114592	0	0.0		J	CUM		638232	9	0.0141		ZA	73	2	119856	1	0.0083				
A	CUM		658240	2	0.0030		L	71	2	32932	0	0.0		ZA	74	2	53166	2	0.0376				
B	70	2	23764	0	0.0		L	73	2	83280	0	0.0		ZA	75	2	53456	6	0.1122				
B	71	2	121028	1	0.0083		L	74	2	115348	3	0.0260		ZA	76	2	56518	1	0.0177				
B	72	2	143226	1	0.0070		L	75	2	142112	13	0.0915		ZA	CUM		567556	13	0.0229				
B	73	2	127034	4	0.0315		L	76	4	323748	38	0.1174		ZB	70	2	48036	0	0.0				
B	74	2	121224	7	0.0577		L	CUM		697420	54	0.0774		ZB	71	2	97886	1	0.0102				
B	75	2	98826	14	0.1417		R	71	2	21022	0	0.0		ZB	72	2	162366	5	0.0308				
B	76	2	76756	3	0.0391		R	72	2	53632	0	0.0		ZB	74	2	214386	18	0.0840				
B	CUM		711858	30	0.0421		R	73	2	54428	0	0.0		ZB	75	2	210276	22	0.1046	100			
D	73	2	61774	1	0.0162		R	74	2	55062	0	0.0		ZB	76	2	213894	22	0.1029	100			
D	CUM		61774	1	0.0162		R	75	2	57682	0	0.0		ZB	CUM		946844	68	0.0718				
H	70	2	10810	0	0.0		R	CUM		241826	0	0.0		ZD	76	2	93912	3	0.0319				
H	71	2	34130	0	0.0		S	71	2	12078	0	0.0		ZD	CUM		93912	3	0.0319				
H	72	2	64732	1	0.0154		S	72	2	19024	1	0.0526		ALL	70		240216	0	0.0				
H	73	2	87214	1	0.0115		S	73	2	18376	1	0.0544		ALL	71		711442	5	0.0070				
H	74	2	115100	0	0.0		S	CUM		45480	2	0.0404		ALL	72		928304	11	0.0118				
H	75	2	151280	5	0.0331		Z	71	2	3624	0	0.0		ALL	73		831304	13	0.0156				
H	76	2	161498	12	0.0743	100	Z	72	2	26888	0	0.0		ALL	74		854524	32	0.0374				
H	CUM		624764	19	0.0304		Z	73	2	41668	0	0.0		ALL	75		902456	62	0.0687				
J	70	2	13296	0	0.0		Z	74	2	63358	2	0.0316		ALL	76		1132814	85	0.0750				
J	71	2	67582	0	0.0		Z	75	2	81588	1	0.0123		ALL	CUM		5601060	208	0.0371	100			
J	72	2	95698	1	0.0104		Z	76	2	92028	4	0.0435											
J	73	2	123080	5	0.0406		Z	CUM		309154	7	0.0226											

747 COMPONENT REMOVAL DATA

OP	YR	OPA	UNIT HOURS	NO. REM	RATE	Z JJS	OP	YR	OPA	UNIT HOURS	NO. REM	RATE	Z JUS	OP	YR	OPA	UNIT HOURS	NO. REM	RATE	Z JUS
27-11-675-0112 CONTROL UNIT, AIL POWER (OUTBD)							P/N: 60800051													
A	70	2	110200	0	0.0		J	73	2	123080	0	0.0		ZA	71	2	127404	0	0.0	
A	71	2	193756	0	0.0		J	74	2	116880	10	0.0856		ZA	72	2	123046	0	0.0	
A	72	2	239692	0	0.0		J	75	2	107236	3	0.0280		ZA	73	2	119856	1	0.0083	
A	73	2	114592	0	0.0		J	76	2	114460	1	0.0087		ZA	74	2	53166	1	0.0188	
A	CUM		658240	0	0.0		J	CUM		638232	15	0.0235		ZA	75	2	53456	1	0.0187	
B	70	2	23764	0	0.0		L	71	2	32932	0	0.0		ZA	76	2	56518	1	0.0177	
B	71	2	121028	0	0.0		L	73	2	83280	1	0.0120		ZA	CUM		567556	4	0.0070	
B	72	2	143226	2	0.0140		L	74	2	115348	2	0.0173		ZB	70	2	48036	0	0.0	
B	73	2	127034	6	0.0472		L	75	2	142112	11	0.0774		ZB	71	2	97886	0	0.0	
B	74	2	121224	8	0.0660		L	CUM		373672	14	0.0375		ZB	72	2	162366	1	0.0062	
B	75	2	98826	6	0.0607		R	71	2	21022	0	0.0		ZB	74	2	214386	16	0.0746	
B	76	2	76756	1	0.0130		R	72	2	53632	0	0.0		ZB	75	2	210276	18	0.0856	100
B	CUM		711858	23	0.0323		R	73	2	54428	0	0.0		ZB	76	2	213894	9	0.0421	
D	73	2	61774	0	0.0		R	74	2	55062	0	0.0		ZB	CUM		946844	44	0.0465	
D	CUM		61774	0	0.0		R	75	2	57682	0	0.0		ZD	76	2	93912	0	0.0	
H	70	2	10810	0	0.0		R	CUM		241826	0	0.0		ZD	CUM		93912	0	0.0	
H	71	2	34130	0	0.0		S	71	2	12078	0	0.0		ALL	70		240216	0	0.0	
H	72	2	64732	0	0.0		S	CUM		12078	0	0.0		ALL	71		711442	0	0.0	
H	73	2	87214	1	0.0115		Z	71	2	3624	0	0.0		ALL	72		909280	4	0.0044	
H	74	2	115100	4	0.0348		Z	72	2	26888	0	0.0		ALL	73		812926	9	0.0111	
H	75	2	151280	5	0.0331		Z	73	2	41668	0	0.0		ALL	74		854524	42	0.0492	
H	76	2	161498	3	0.0186		Z	74	2	63358	1	0.0159		ALL	75		902456	45	0.0499	
H	CUM		624764	13	0.0208		Z	75	2	81588	1	0.0123		ALL	76		809066	17	0.0210	
J	70	2	13296	0	0.0		Z	76	2	92028	2	0.0217		ALL	CUM		5239910	117	0.0223	100
J	71	2	67582	0	0.0		Z	CUM		309154	4	0.0129								
J	72	2	95698	1	0.0104		ZA	70	2	34110	0	0.0								

27-11-980-011 LOCKOUT MECHM, OUTBD AILERON CONT

P/N: 65880510

A	70	2	110200	0	0.0		H	CUM		311986	0	0.0		Z	72	2	26888	0	0.0	
A	71	2	193756	0	0.0		J	70	2	13296	0	0.0		Z	73	2	41668	0	0.0	
A	72	2	239692	0	0.0		J	71	2	67582	0	0.0		Z	74	2	63358	0	0.0	
A	73	2	114592	0	0.0		J	72	2	95698	0	0.0		Z	CUM		135538	0	0.0	
A	CUM		658240	0	0.0		J	73	2	123080	0	0.0		ZA	70	2	34110	0	0.0	
B	70	2	23764	0	0.0		J	74	2	116880	0	0.0		ZA	71	2	127404	0	0.0	
B	71	2	121028	0	0.0		J	CUM		416536	0	0.0		ZA	72	2	123046	0	0.0	
B	72	2	143226	0	0.0		R	71	2	21022	0	0.0		ZA	CUM		284560	0	0.0	
B	73	2	127034	0	0.0		R	72	2	53632	0	0.0		ALL	70		192180	0	0.0	
B	74	2	121224	0	0.0		R	73	2	54428	0	0.0		ALL	71		580624	0	0.0	
B	CUM		536276	0	0.0		R	74	2	55062	0	0.0		ALL	72		765938	0	0.0	
H	70	2	10810	0	0.0		R	CUM		184144	0	0.0		ALL	73		548016	0	0.0	
H	71	2	34130	0	0.0		S	71	2	12078	0	0.0		ALL	74		471624	0	0.0	
H	72	2	64732	0	0.0		S	72	2	19024	0	0.0		ALL	CUM		2558382	0	0.0	
H	73	2	87214	0	0.0		S	CUM		31102	0	0.0								
H	74	2	115100	0	0.0		Z	71	2	3624	0	0.0								

747 COMPONENT REMOVAL DATA

OP	YR	OPA	UNIT HOURS	NO. REM	RATE	% JUS	OP	YR	OPA	UNIT HOURS	NO. REM	RATE	% JUS	OP	YR	OPA	UNIT HOURS	NO. REM	RATE	% JUS
27-18-556-121 TRANSMITTER, AIL PSN							P/N: 60B40042-1													
A	70	2	110200	6	0.0544		J	70	2	13296	1	0.0752		S	CUM		12078	0	0.0	
A	71	2	193756	8	0.0413		J	71	2	67582	4	0.0592		T	71	2	6770	0	0.0	
A	72	2	239692	8	0.0334		J	72	2	95698	1	0.0104		T	72	2	16662	0	0.0	
A	CUM		543648	22	0.0405		J	CUM		176576	6	0.0340		T	CUM		23432	0	0.0	
B	70	2	23764	2	0.0842		R	71	2	21022	0	0.0		ALL	70		147260	9	0.0611	
B	71	2	121028	4	0.0331		R	72	2	53632	0	0.0		ALL	71		422236	16	0.0379	
B	72	2	143226	11	0.0768		R	CUM		74654	0	0.0		ALL	72		548910	20	0.0364	
B	CUM		288018	17	0.0590		S	71	2	12078	0	0.0		ALL	CUM		1118406	45	0.0402	
27-21-008-021 ACTUATOR, RUDDR TRIM MANUAL							P/N: 65-218J1-12													
A	70	1	55100	1	0.0181		H	CUM		155993	0	0.0		Z	71	1	1812	0	0.0	
A	71	1	96878	1	0.0103		J	70	1	6648	0	0.0		Z	72	1	13444	0	0.0	
A	72	1	119846	1	0.0083		J	71	1	33791	1	0.0296		Z	73	1	20834	0	0.0	
A	73	1	57296	0	0.0		J	72	1	47849	0	0.0		Z	74	1	31679	0	0.0	
A	CUM		329120	3	0.0091		J	73	1	61540	0	0.0		Z	CUM		67769	0	0.0	
B	70	1	11882	0	0.0		J	74	1	58440	0	0.0		ZA	70	1	17055	0	0.0	
B	71	1	60514	0	0.0		J	CUM		208268	1	0.0048		ZA	71	1	63702	0	0.0	
B	72	1	71613	0	0.0		L	71	1	16466	1	0.0607		ZA	72	1	61523	0	0.0	
B	73	1	63517	0	0.0		L	73	1	41640	0	0.0		ZA	CUM		142280	0	0.0	
B	74	1	60612	0	0.0		L	74	1	57674	0	0.0		ALL	70		96090	1	0.0104	
B	CUM		268138	0	0.0		L	CUM		115780	1	0.0086		ALL	71		300739	3	0.0100	
H	70	1	5405	0	0.0		R	71	1	10511	0	0.0		ALL	72		373457	1	0.0027	
H	71	1	17065	0	0.0		R	72	1	26816	0	0.0		ALL	73		315648	0	0.0	
H	72	1	32366	0	0.0		R	73	1	27214	0	0.0		ALL	74		293486	0	0.0	
H	73	1	43607	0	0.0		R	74	1	27531	0	0.0		ALL	CUM		1379420	5	0.0036	
H	74	1	57550	0	0.0		R	CUM		92072	0	0.0								
27-21-008-341 ACTUATOR, RUDDR RATIO CHGR(SERVO)							P/N: 60B80031-()													
A	70	2	110200	84	0.7623		J	73	2	123080	11	0.0894		Z	76	2	92028	15	0.1630	
A	71	2	193756	80	0.4129		J	74	2	116880	11	0.0941		Z	CUM		309154	30	0.0970	
A	72	2	239692	65	0.2712		J	75	2	107236	15	0.1399		ZA	70	2	34110	0	0.0	
A	CUM		543648	229	0.4212		J	76	2	114460	21	0.1835		ZA	71	2	127404	51	0.4003	
B	70	2	23764	15	0.6312		J	CUM		638232	95	0.1488		ZA	72	2	123046	44	0.3576	
B	71	2	121028	32	0.2644		L	71	2	32932	9	0.2733		ZA	73	2	119856	29	0.2420	
B	72	2	143226	24	0.1676		L	73	2	83280	2	0.0240		ZA	74	2	53166	16	0.3009	
B	73	2	127034	27	0.2125		L	74	2	115348	12	0.1040		ZA	75	2	53456	11	0.2058	
B	74	2	121224	14	0.1155		L	75	2	142112	7	0.0493		ZA	76	2	56518	6	0.1062	
B	75	2	98826	8	0.0810		L	76	2	161874	10	0.0618		ZA	CUM		567556	157	0.2766	
B	76	2	76756	7	0.0912		L	CUM		535546	40	0.0747		ZB	70	2	48036	15	0.3123	
B	CUM		711858	127	0.1784		R	71	2	21022	0	0.0		ZB	71	2	97886	37	0.3780	59
D	73	2	61774	4	0.0648		R	72	2	53632	5	0.0932		ZB	72	2	162366	31	0.1909	
D	CUM		61774	4	0.0648		R	73	2	54428	4	0.0735		ZB	74	2	214386	17	0.0793	
H	70	2	10810	6	0.5550	100	R	74	2	55062	3	0.0545		ZB	75	2	210276	13	0.0618	40

(CONTINUED ON NEXT PAGE)

B-9

747 COMPONENT REMOVAL DATA																					
OP	YR	QPA	UNIT HOURS	NO. REM	RATE	Σ JUS	OP	YR	QPA	UNIT HOURS	NO. REM	RATE	Σ JUS	OP	YR	QPA	UNIT HOURS	NO. REM	RATE	Σ JUS	
27-21-008-341			ACTUATOR, RUDDR RATIO CHGR(SERVO)			(CONTINUED)			P/N: 60880031-()												
H	71	2	34130	3	0.0879	50	R	CUM		184144	12	0.0652		ZB	76	2	213894	16	0.0748		
H	72	2	6732	9	0.1390	29	S	71	2	12078	3	0.2484		ZB	CUM		946844	129	0.1362		
H	73	2	87214	15	0.1720		S	CUM		12078	3	0.2484		ALL	70		240216	123	0.5120		
H	74	2	115100	19	0.1651		T	73	2	17098	1	0.0585		ALL	71		711442	236	0.3317		
H	75	2	151280	34	0.2247	30	T	CUM		17098	1	0.0585		ALL	72		909280	193	0.2123		
H	76	2	161498	4	0.0248		Z	71	2	3624	0	0.0		ALL	73		715432	94	0.1314		
H	CUM		624764	90	0.1441		Z	72	2	26888	2	0.0744		ALL	74		854524	95	0.1112		
J	70	2	13296	3	0.2256		Z	73	2	41668	1	0.0240		ALL	75		844774	97	0.1148		
J	71	2	67582	21	0.3107		Z	74	2	63358	3	0.0473		ALL	76		877028	79	0.0901		
J	72	2	95698	13	0.1358		Z	75	2	81588	9	0.1103		ALL	CUM		5152696	917	0.1780	44	
27-21-404-061			QUADRANT, RUDDR CONTROL						P/N: 65881213												
B	70	2	23764	0	0.0		J	73	2	123080	0	0.0		Z	74	2	63358	0	0.0		
B	71	2	121028	0	0.0		J	74	2	116880	0	0.0		Z	CUM		135538	0	0.0		
B	72	2	143226	0	0.0		J	CUM		416536	2	0.0048		ALL	70		37060	0	0.0		
B	73	2	127034	0	0.0		R	73	2	54428	0	0.0		ALL	71		192234	0	0.0		
B	74	2	121224	0	0.0		R	74	2	55062	0	0.0		ALL	72		265812	2	0.0075		
B	CUM		536276	0	0.0		R	CUM		109490	0	0.0		ALL	73		346210	0	0.0		
J	70	2	13296	0	0.0		Z	71	2	3624	0	0.0		ALL	74		356524	0	0.0		
J	71	2	67582	0	0.0		Z	72	2	26888	0	0.0		ALL	CUM		1197840	2	0.0017		
J	72	2	95698	2	0.0209		Z	73	2	41668	0	0.0									
27-21-418-021			REGULATOR, RUDDR CONT QUAD TENS						P/N: SEE 27-21-404-061												
27-21-675-021			CONTRQL UNIT, RUDDR POWER (PCU)						P/N: 60800049												
A	70	2	110200	3	0.0272		J	75	2	107236	9	0.0839		Z	CUM		309154	19	0.0615		
A	71	2	193756	1	0.0052		J	76	2	114460	5	0.0437	80	ZA	70	2	34110	0	0.0		
A	72	2	235692	3	0.0125		J	CUM		638232	47	0.0736		ZA	71	2	127404	0	0.0		
A	73	2	114592	3	0.0262		L	71	2	32932	0	0.0		ZA	72	2	123046	3	0.0244		
A	CUM		658240	10	0.0152		L	72	2	88612	0	0.0		ZA	73	2	119856	9	0.0751		
B	70	2	23764	0	0.0		L	73	2	83280	2	0.0240		ZA	74	2	53166	3	0.0564		
B	71	2	121028	3	0.0248		L	74	2	115348	9	0.0780		ZA	75	2	53456	1	0.0187		
B	72	2	143226	6	0.0419		L	75	2	142112	25	0.1759		ZA	76	2	56518	3	0.0531		
B	73	2	127034	7	0.0551		L	76	2	161874	25	0.1544		ZA	CUM		567556	19	0.0335		
B	74	2	121224	11	0.0907		L	CUM		624158	61	0.0977		ZB	73	2	202836	5	0.0247		
B	75	2	98826	7	0.0708		R	71	2	21022	0	0.0		ZB	74	2	214386	19	0.0886		
B	76	2	76756	4	0.0521		R	72	2	53632	1	0.0186		ZB	75	2	210276	26	0.1236	90	
B	CUM		711858	38	0.0534		R	73	2	54428	1	0.0184		ZB	76	2	213894	26	0.1216	100	
H	70	2	16810	0	0.0		R	74	2	55062	4	0.0726		ZB	CUM		841392	76	0.0903		
H	71	2	34130	1	0.0293		R	75	2	57682	1	0.0173		ZD	76	2	93912	3	0.0319		
H	72	2	64732	0	0.0		R	CUM		241826	7	0.0289		ZD	CUM		93912	3	0.0319		
H	73	2	87214	0	0.0		S	71	2	12078	2	0.1656		ALL	70		192180	4	0.0208		

(CONTINUED ON NEXT PAGE)

747 COMPONENT REMOVAL DATA																				
UP	YR	QPA	UNIT HOURS	NO. REM	RATE	% JUS	OP	YR	QPA	UNIT HOURS	NO. REM	RATE	% JUS	OP	YR	QPA	UNIT HOURS	NO. REM	RATE	% JUS
27-21-675-021			CONTROL UNIT, RUDDR POWER (PCU) (CONTINUED) P/N: 60800049																	
H	74	2	115100	0	0.0		S	CUM		12078	2	0.1656		ALL	71		613556	9	0.0147	
H	75	2	151280	9	0.0595		T	73	2	17098	1	0.0585		ALL	72		835526	15	0.0180	
H	76	2	161498	15	0.0929	100	T	CUM		17098	1	0.0585		ALL	73		971086	50	0.0515	
H	CUM		624764	25	0.0400		Z	71	2	3624	0	0.0		ALL	74		854524	53	0.0620	
J	70	2	13296	1	0.0752		Z	72	2	26888	0	0.0		ALL	75		902456	83	0.0920	
J	71	2	67582	2	0.0296		Z	73	2	41668	0	0.0		ALL	76		970940	94	0.0968	
J	72	2	95698	2	0.0209		Z	74	2	63358	1	0.0158		ALL	CUM		5340268	308	0.0577	94
J	73	2	123080	22	0.1787	91	Z	75	2	81588	5	0.0613								
J	74	2	116880	6	0.0513		Z	76	2	92028	13	0.1413								
27-21-675-191			CONTROL UNIT, RUDDR RATIO CHGR P/N: 60880031																	
A	73	2	114592	5	0.0436		L	73	2	83280	6	0.0720		ZA	71	2	127404	33	0.2590	
A	CUM		114592	5	0.0436		L	74	2	115348	23	0.1994		ZA	72	2	123046	30	0.2438	
B	73	2	127034	33	0.2598		L	75	2	142112	16	0.1126		ZA	73	2	119856	23	0.1919	
B	74	2	121224	31	0.2557		L	76	2	161874	8	0.0494		ZA	74	2	53166	17	0.3198	
B	75	2	98826	12	0.1214		L	CUM		535546	59	0.1102		ZA	75	2	53456	11	0.2058	
B	CUM		347084	76	0.2190		R	71	2	21022	0	0.0		ZA	76	2	56518	3	0.0531	
H	70	2	10810	1	0.0925		R	72	2	53632	8	0.1492		ZA	CUM		533446	117	0.2193	
H	71	2	34130	6	0.1758		R	73	2	54428	13	0.2388		ZB	73	2	202836	31	0.1528	
H	72	2	64732	14	0.2163		R	74	2	55062	16	0.2906		ZB	74	2	214386	6	0.0280	
H	73	2	87214	17	0.1949		R	75	2	57682	3	0.0520		ZB	75	2	210276	25	0.1189	50
H	74	2	115100	27	0.2346		R	CUM		241826	40	0.1654		ZB	76	2	213894	42	0.1964	54
H	75	2	151280	52	0.3437	60	S	71	2	12078	3	0.2484		ZB	CUM		841392	104	0.1236	
H	76	2	161498	20	0.1238	53	S	CUM		12078	3	0.2484		ZD	76	2	93912	7	0.0745	
H	CUM		624764	137	0.2193		T	71	2	6770	0	0.0		ZD	CUM		93912	7	0.0745	
J	70	2	13296	2	0.1504		T	72	2	16662	3	0.1801		ALL	70		24106	3	0.1245	
J	71	2	67582	14	0.2072		T	CUM		23432	3	0.1280		ALL	71		305542	62	0.2029	
J	72	2	95698	19	0.1985		Z	71	2	3624	0	0.0		ALL	72		380658	76	0.1997	
J	73	2	123080	0	0.0		Z	72	2	26888	2	0.0744		ALL	73		953988	135	0.1415	
J	74	2	116880	17	0.1454		Z	73	2	41668	7	0.1680		ALL	74		854524	141	0.1650	
J	75	2	107236	26	0.2425		Z	74	2	63358	4	0.0631		ALL	75		902456	153	0.1695	
J	76	2	114460	37	0.3233	38	Z	75	2	81588	8	0.0981		ALL	76		894184	126	0.1409	
J	CUM		638232	115	0.1802		Z	76	2	92028	9	0.0978		ALL	CUM		4315458	696	0.1613	52
L	71	2	32932	6	0.1822		Z	CUM		309154	30	0.0970								
27-21-677-071			CON/U. RUDDR FEEL TRIM AND CTRNG P/N: 65881020																	
A	70	1	55100	0	0.0		A	CUM		271824	0	0.0		ALL	72		119846	0	0.0	
A	71	1	96878	0	0.0		ALL	70		55100	0	0.0		ALL	CUM		271824	0	0.0	
A	72	1	119846	0	0.0		ALL	71		96878	0	0.0								

B-10

B-11

747 COMPONENT REMOVAL DATA

DP	YR	OPA	UNIT HOURS	NO. REM	RATE	% JUS	DP	YR	OPA	UNIT HOURS	NO. REM	RATE	% JUS	DP	YR	OPA	UNIT HOURS	NO. REM	RATE	% JUS
27-28-121-021							COMPARATOR. RUDDR RATIO CHGR							P/N: 60840073-()						
A	70	1	55100	28	0.5082		H	CUM		306977	37	0.1205		ZA	71	1	63702	28	0.4395	
A	71	1	96878	37	0.3819		L	71	1	16466	8	0.4858		ZA	72	1	61523	29	0.4714	
A	72	1	119846	31	0.2587		L	73	1	41640	10	0.2402		ZA	73	1	59928	19	0.3170	
A	73	1	57296	3	0.0524		L	74	1	57674	17	0.2948		ZA	74	1	26583	11	0.4138	
A	CUM		329120	99	0.3008		L	75	1	71056	4	0.0563		ZA	75	1	26728	5	0.1871	
B	70	1	11882	15	1.2624		L	76	1	80937	9	0.1112		ZA	76	1	28259	2	0.0708	
B	71	1	60514	20	0.3305		L	CUM		267773	48	0.1793		ZA	CUM		283778	102	0.3594	
B	72	1	71613	38	0.5306		R	71	1	10511	3	0.2854		ZB	75	1	105138	12	0.1141	
B	73	1	63517	51	0.8029		R	72	1	26816	1	0.0373		ZB	76	1	106947	20	0.1870	
B	74	1	60612	23	0.3795		R	73	1	27214	4	0.1470		ZB	CUM		212085	32	0.1509	
B	75	1	49413	11	0.2226		R	74	1	27531	3	0.1090		ZU	76	1	46956	2	0.0426	
B	76	1	38378	1	0.0261		R	CUM		92072	11	0.1195		ZD	CUM		46956	2	0.0426	
B	CUM		355929	159	0.4467		S	71	1	6039	1	0.1656		ALL	70		84037	51	0.6069	
D	73	1	30687	6	0.1943		S	CUM		6039	1	0.1656		ALL	71		272987	101	0.3700	
D	74	1	23604	3	0.1271		Z	71	1	1812	0	0.0		ALL	72		325608	109	0.3348	
D	CUM		54491	9	0.1652		Z	72	1	13444	2	0.1488		ALL	73		344923	103	0.2986	
H	71	1	17065	4	0.2344		Z	73	1	20834	3	0.1440		ALL	74		285233	63	0.2209	
H	72	1	32366	8	0.2472		Z	74	1	31679	1	0.0316		ALL	75		368769	49	0.1329	
H	73	1	43607	7	0.1605		Z	75	1	40794	8	0.1961		ALL	76		428240	40	0.0934	
H	74	1	57550	5	0.0869		Z	76	1	46014	2	0.0435		ALL	CUM		2109797	516	0.2446	100
H	75	1	75640	9	0.1190	100	Z	CUM		154577	16	0.1035								
H	76	1	80749	4	0.0495		ZA	70	1	17055	8	0.4691								
27-31-008-151							ACTUATOR. ELEV FEEL HYD							P/N: 65881875						
A	70	1	55100	0	0.0		J	75	1	53618	0	0.0		ZA	71	1	63702	0	0.0	
A	71	1	96878	0	0.0		J	76	1	57230	1	0.0175		ZA	72	1	61523	1	0.0163	
A	72	1	119846	5	0.0417		J	CUM		257576	7	0.0272		ZA	73	1	59928	5	0.0834	
A	73	1	57296	1	0.0175		L	71	1	16466	0	0.0		ZA	74	1	26583	0	0.0	
A	CUM		329120	6	0.0182		L	73	1	41640	1	0.0240		ZA	75	1	26728	0	0.0	
B	70	1	11882	0	0.0		L	74	1	57674	1	0.0173		ZA	76	1	28259	0	0.0	
B	71	1	60514	1	0.0165		L	75	1	71056	1	0.0141		ZA	CUM		283778	6	0.0211	
B	72	1	71613	1	0.0140		L	76	1	80937	1	0.0124		ZB	70	1	24018	0	0.0	
B	73	1	63517	0	0.0		L	CUM		267773	4	0.0149		ZB	71	1	48943	0	0.0	
B	74	1	60612	0	0.0		R	71	1	10511	0	0.0		ZB	72	1	81183	1	0.0123	
B	75	1	49413	0	0.0		R	72	1	26816	0	0.0		ZB	73	1	101418	0	0.0	
B	76	1	38378	0	0.0		R	73	1	61540	3	0.0487		ZB	74	1	107193	3	0.0280	
B	CUM		355929	2	0.0056		R	74	1	27531	2	0.0726		ZB	75	1	105138	0	0.0	
H	70	1	5405	0	0.0		R	75	1	28841	1	0.0347		ZB	76	1	106947	3	0.0281	
H	71	1	17065	0	0.0		R	CUM		155239	6	0.0387		ZB	CUM		574840	7	0.0122	
H	72	1	32366	1	0.0309		S	71	1	6039	0	0.0		ZD	76	1	46956	0	0.0	
H	73	1	43607	1	0.0229		S	CUM		6039	0	0.0		ZD	CUM		46956	0	0.0	
H	74	1	57550	0	0.0		Z	71	1	1812	0	0.0		ALL	70		120108	0	0.0	
H	75	1	75640	0	0.0		Z	72	1	13444	2	0.1488		ALL	71		355721	3	0.0084	
H	76	1	80749	0	0.0		Z	73	1	20834	0	0.0		ALL	72		454640	13	0.0286	

(CONTINUED ON NEXT PAGE)

B-12

747 COMPONENT REMOVAL DATA																				
OP	YR	OPA	UNIT HOURS	NO. REM	RATE	% JUS	OP	YR	OPA	UNIT HOURS	NO. REM	RATE	% JUS	OP	YR	OPA	UNIT HOURS	NO. REM	RATE	% JUS
27-31-008-151 ACTUATOR, ELEV FEEL HYD							(CONTINUED) P/N: 65B81875													
H	CUM		312382	2	0.0064		Z	74	1	31679	0	0.0		ALL	73		449780	11	0.0245	
J	70	1	6648	0	0.0		Z	75	1	40794	1	0.0245		ALL	74		427262	8	0.0187	
J	71	1	33791	2	0.0592		Z	76	1	46014	3	0.0652		ALL	75		451228	3	0.0066	
J	72	1	47849	2	0.0418		Z	CUM		154577	6	0.0388		ALL	76		485470	8	0.0165	
J	74	1	58440	2	0.0342		ZA	70	1	17055	0	0.0		ALL	CUM		2744209	46	0.0168	
27-31-122-011 COLUMN, ELEV CONT							P/N: SEE 27-00-122-021													
27-31-130-021 COMPUTER, ELEV FEEL							P/N: 60B00055													
A	70	1	55100	0	0.0		J	76	1	57230	6	0.1048	83	ZA	70	1	17055	0	0.0	
A	71	1	96878	7	0.0723		J	CUM		319116	11	0.0345		ZA	71	1	63702	1	0.0157	
A	72	1	119840	11	0.0918		L	71	1	16466	0	0.0		ZA	72	1	61523	7	0.1138	
A	CUM		271824	18	0.0662		L	73	1	41640	1	0.0240		ZA	73	1	59928	7	0.1168	
B	70	1	11882	1	0.0842		L	74	1	57674	1	0.0173		ZA	74	1	26583	3	0.1129	
B	71	1	60514	2	0.0331		L	75	1	71056	5	0.0704		ZA	75	1	26728	4	0.1497	
B	72	1	71613	1	0.0140		L	76	1	80937	4	0.0494		ZA	76	1	28259	3	0.1062	
B	73	1	63517	4	0.0630		L	CUM		267773	11	0.0411		ZA	CUM		283778	25	0.0881	
B	74	1	60612	5	0.0825		R	71	1	10511	0	0.0		ZB	70	1	24018	1	0.0416	
B	75	1	49413	1	0.0202		R	72	1	26816	0	0.0		ZB	71	1	48943	6	0.1635	
B	76	1	38378	6	0.1563		R	73	1	27214	1	0.0367		ZB	72	1	81183	5	0.0616	100
B	CUM		355929	20	0.0562		R	74	1	27531	1	0.0363		ZB	73	1	101418	5	0.0493	
H	70	1	5405	0	0.0		R	75	1	28841	1	0.0347		ZB	74	1	107193	14	0.1306	
H	71	1	17065	0	0.0		R	CUM		120913	3	0.0248		ZB	75	1	105138	6	0.0571	100
H	72	1	32366	3	0.0927		S	71	1	6039	0	0.0		ZB	76	1	106947	16	0.1496	75
H	73	1	43607	2	0.0459		S	CUM		6039	0	0.0		ZB	CUM		574840	55	0.0957	
H	74	1	57550	3	0.0521		T	71	1	3385	1	0.2954		ZD	76	1	46956	0	0.0	
H	75	1	75640	2	0.0264		T	72	1	8331	1	0.1200		ZD	CUM		46956	0	0.0	
H	76	1	80749	5	0.0619	75	T	CUM		11716	2	0.1707		ALL	70		120108	2	0.0167	
H	CUM		312382	15	0.0480		Z	71	1	1812	0	0.0		ALL	71		359106	19	0.0529	
J	70	1	6648	0	0.0		Z	72	1	13444	0	0.0		ALL	72		462971	29	0.0626	
J	71	1	33791	0	0.0		Z	73	1	20834	1	0.0480		ALL	73		419698	21	0.0500	
J	72	1	47849	1	0.0209		Z	74	1	31679	2	0.0631		ALL	74		427262	32	0.0749	
J	73	1	61540	0	0.0		Z	75	1	40794	1	0.0245		ALL	75		451228	21	0.0465	
J	74	1	58440	3	0.0513		Z	76	1	46014	7	0.1521		ALL	76		485470	47	0.0968	
J	75	1	53618	1	0.0187		Z	CUM		154577	11	0.0712		ALL	CUM		2725843	171	0.0627	84
27-31-404-091 QUADRANT, ELEV CONTROL							P/N: 65B80310													
J	70	1	6648	0	0.0		R	72	1	26816	0	0.0		ZA	71	1	63702	0	0.0	
J	71	1	33791	0	0.0		R	73	1	27214	0	0.0		ZA	72	1	61523	0	0.0	
J	72	1	47849	0	0.0		R	74	1	27531	0	0.0		ZA	73	1	59928	0	0.0	
J	73	1	61540	0	0.0		R	CUM		92072	0	0.0		ZA	74	1	26583	0	0.0	
J	74	1	58440	0	0.0		S	71	1	6039	0	0.0		ZA	CUM		228791	0	0.0	
(CONTINUED ON NEXT PAGE)																				

B-13

747 COMPONENT REMOVAL DATA																				
OP	YR	QPA	UNIT HOURS	NU. REM	RATE	% JJS	OP	YR	QPA	UNIT HOURS	NU. REM	RATE	% JJS	OP	YR	QPA	UNIT HOURS	NO. REM	RATE	% JJS
27-31-404-091			QUADRANT. ELEV CONTROL				(CONTINUED) P/N: 65B80310													
J	CUM		208268	0	0.0		S	72	1	9512	0	0.0		ALL	70		23703	0	0.0	
L	71	1	16466	0	0.0		S	CUM		15551	0	0.0		ALL	71		130509	0	0.0	
L	73	1	41640	0	0.0		Z	73	1	20834	0	0.0		ALL	72		145700	0	0.0	
L	74	1	57674	0	0.0		Z	74	1	31679	0	0.0		ALL	73		211156	0	0.0	
L	CUM		115780	0	0.0		Z	CUM		52513	0	0.0		ALL	74		201907	0	0.0	
R	71	1	10511	0	0.0		ZA	70	1	17055	0	0.0		ALL	CUM		712975	0	0.0	
27-31-418-011			REGULATOR. ELEV CONT QUAD TENS				P/N: SEE 27-31-404-091													
27-31-675-0511			CONTROL UNIT. ELEV POWER (INBD)				P/N: 60B00047													
A	70	2	110200	1	0.0091		J	75	2	107236	5	0.0466		ZA	71	2	127404	5	0.0392	
A	71	2	193756	4	0.0206		J	76	2	114460	5	0.0437	80	ZA	72	2	123046	4	0.0325	
A	72	2	239692	5	0.0209		J	CUM		638232	27	0.0423		ZA	73	2	119856	3	0.0250	
A	CUM		543648	10	0.0184		L	71	2	32932	0	0.0		ZA	74	2	53166	2	0.0376	
B	70	2	23764	0	0.0		L	73	2	83280	3	0.0360		ZA	75	2	53456	4	0.0748	
B	71	2	121028	0	0.0		L	74	2	115348	14	0.1214		ZA	76	2	56518	3	0.0531	
B	72	2	143226	2	0.0140		L	75	2	142112	17	0.1196		ZA	CUM		567556	21	0.0370	
B	73	2	127034	2	0.0157		L	76	4	323748	44	0.1359		ZB	70	2	48036	0	0.0	
B	74	2	121224	13	0.1072		L	CUM		697420	78	0.1118		ZB	71	2	97886	2	0.0204	
B	75	2	98826	11	0.1113		R	71	2	21022	0	0.0		ZB	72	2	162366	9	0.0554	100
B	76	2	76756	4	0.0521		R	72	2	53632	1	0.0186		ZB	73	2	202836	4	0.0197	
B	CUM		711858	32	0.0450		R	73	2	54428	1	0.0184		ZB	74	2	214386	22	0.1026	
H	70	2	10810	0	0.0		R	74	2	55062	0	0.0		ZB	75	2	210276	30	0.1427	90
H	71	2	34130	0	0.0		R	75	2	57682	0	0.0		ZB	76	2	213894	33	0.1543	94
H	72	2	64732	3	0.0463		R	CUM		241826	2	0.0083		ZB	CUM		1149680	100	0.0870	
H	73	2	87214	6	0.0688		S	71	2	12078	0	0.0		ZD	76	4	187824	9	0.0479	
H	74	2	115100	2	0.0174		S	CUM		12078	0	0.0		ZD	CUM		187824	9	0.0479	
H	75	2	151280	17	0.1124	90	Z	71	2	3624	0	0.0		ALL	70		240216	2	0.0083	
H	76	2	161498	18	0.1115	100	Z	72	2	26888	1	0.0372		ALL	71		711442	11	0.0155	
H	CUM		624764	46	0.0736		Z	73	2	41668	1	0.0240		ALL	72		909280	27	0.0297	
J	70	2	13296	1	0.0752		Z	74	2	63358	5	0.0789		ALL	73		839396	23	0.0274	
J	71	2	67582	0	0.0		Z	75	2	81588	9	0.1103		ALL	74		854524	69	0.0807	
J	72	2	95698	2	0.0209		Z	76	2	92028	16	0.1739		ALL	75		902456	93	0.1031	
J	73	2	123080	3	0.0244		Z	CUM		309154	32	0.1035		ALL	76		1226726	132	0.1076	
J	74	2	116880	11	0.0941		ZA	70	2	34110	0	0.0		ALL	CUM		5684040	357	0.0628	93
27-31-675-0512			CONTROL UNIT. ELEV POWER (OUTBD)				P/N: 60B00048													
A	70	2	110200	0	0.0		J	76	2	114460	0	0.0		ZA	70	2	34110	0	0.0	
A	71	2	193756	0	0.0		J	CUM		638232	4	0.0063		ZA	71	2	127404	2	0.0157	
A	72	2	235692	0	0.0		L	71	2	32932	0	0.0		ZA	72	2	123046	5	0.0406	
A	CUM		543648	0	0.0		L	73	2	83280	0	0.0		ZA	73	2	119856	4	0.0334	
B	70	2	23764	0	0.0		L	74	2	115348	4	0.0347		ZA	74	2	53166	2	0.0376	

(CONTINUED ON NEXT PAGE)

B-14

747 COMPONENT REMOVAL DATA																							
OP	YR	OPA	UNIT HOURS	NO. REM	RATE	% JUS	OP	YR	OPA	UNIT HOURS	NO. REM	RATE	% JUS	OP	YR	OPA	UNIT HOURS	NO. REM	RATE	% JUS			
27-31-675-0512 CONTROL UNIT, ELEV POWER (OUT8D)							(CONTINUED)							P/N: 60800048									
B	71	2	121026	1	0.0083		L	75	2	142112	17	0.1196		ZA	75	2	53456	3	0.0561				
B	72	2	143226	1	0.0070		L	CUM		373672	21	0.0562		ZA	76	2	56518	2	0.0354				
B	73	2	127034	1	0.0079		R	71	2	21022	0	0.0		ZA	CUM		567556	18	0.0317				
B	74	2	121224	1	0.0082		R	72	2	53632	0	0.0		ZB	70	2	48036	0	0.0				
B	75	2	98826	3	0.0304		R	73	2	54428	0	0.0		ZB	71	2	97886	1	0.0102				
B	76	2	76756	0	0.0		R	74	2	55062	1	0.0182		ZB	72	2	162366	2	0.0123				
B	CUM		711858	7	0.0098		R	75	2	57682	0	0.0		ZB	73	2	202836	3	0.0148				
H	70	2	10770	0	0.0		R	CUM		241826	1	0.0041		ZB	74	2	214386	5	0.0233				
H	71	2	34130	0	0.0		S	71	2	12078	0	0.0		ZB	75	2	210276	5	0.0238	100			
H	72	2	64732	0	0.0		S	72	2	19024	0	0.0		ZB	76	2	213894	7	0.0327				
H	73	2	87214	0	0.0		S	CUM		31102	0	0.0		ZB	CUM		1149680	23	0.0200				
H	74	2	115100	1	0.0087		T	73	2	17098	0	0.0		ALL	70		240176	0	0.0				
H	75	2	151280	4	0.0264		T	74	2	14986	1	0.0667		ALL	71		711442	5	0.0370				
H	76	2	161498	5	0.0310	100	T	CUM		32084	1	0.0312		ALL	72		928304	8	0.0086				
H	CUM		624724	10	0.0160		Z	71	2	3624	0	0.0		ALL	73		856494	10	0.0117				
J	70	2	13296	0	0.0		Z	72	2	26888	0	0.0		ALL	74		869510	16	0.0184				
J	71	2	67582	1	0.0148		Z	73	2	41668	0	0.0		ALL	75		902456	34	0.0377				
J	72	2	95698	0	0.0		Z	74	2	63358	0	0.0		ALL	76		715154	16	0.0224				
J	73	2	123080	2	0.0162		Z	75	2	81588	2	0.0245		ALL	CUM		5223536	89	0.0170	100			
J	74	2	116880	1	0.0086		Z	76	2	92028	2	0.0217											
J	75	2	107236	0	0.0		Z	CUM		309154	4	0.0129											
27-31-675-061 CONTROL UNIT, ELEV FEEL														P/N: 65881226									
A	70	1	55100	0	0.0		H	CUM		155993	0	0.0		T	74	1	7493	0	0.0				
A	71	1	96878	0	0.0		J	70	1	6648	0	0.0		T	CUM		16042	2	0.1247				
A	72	1	119846	0	0.0		J	71	1	33791	0	0.0		ZA	70	1	17055	0	0.0				
A	CUM		271824	0	0.0		J	72	1	47849	0	0.0		ZA	71	1	63702	0	0.0				
B	70	1	11882	0	0.0		J	73	1	61540	0	0.0		ZA	72	1	61523	0	0.0				
B	71	1	60514	0	0.0		J	74	1	58440	0	0.0		ZA	73	1	59928	0	0.0				
B	72	1	71613	0	0.0		J	CUM		208268	0	0.0		ZA	74	1	26583	0	0.0				
B	73	1	63517	0	0.0		R	71	1	10511	0	0.0		ZA	CUM		228791	0	0.0				
B	74	1	60612	0	0.0		R	72	1	26816	0	0.0		ALL	70		96090	0	0.0				
B	CUM		268138	0	0.0		R	73	1	27214	0	0.0		ALL	71		288500	0	0.0				
H	70	1	5405	0	0.0		R	74	1	27531	0	0.0		ALL	72		360013	0	0.0				
H	71	1	17065	0	0.0		R	CUM		92072	0	0.0		ALL	73		264355	2	0.0076				
H	72	1	32366	0	0.0		S	71	1	6039	0	0.0		ALL	74		238209	0	0.0				
H	73	1	43607	0	0.0		S	CUM		6039	0	0.0		ALL	CUM		1247167	2	0.0016				
H	74	1	57550	0	0.0		T	73	1	8549	2	0.2339											
27-32-130-011 COMPUTER, ATUDE AND STALL WARNG														P/N: 60840047-(1)									
A	70	1	55100	19	0.3448		J	76	1	57230	13	0.2272	54	Z	74	1	31679	3	0.0947				
A	71	1	96878	14	0.1445		J	CUM		319116	53	0.1661		Z	75	1	40794	6	0.1471				
A	72	1	119846	10	0.0834		L	71	2	32932	2	0.0607		Z	76	1	46014	4	0.0869				

(CONTINUED ON NEXT PAGE)

747 COMPONENT REMOVAL DATA																				
OP	YR	OPA	UNIT HOURS	NO. REM	RATE	% JUS	OP	YR	OPA	UNIT HOURS	NO. REM	RATE	% JUS	OP	YR	OPA	UNIT HOURS	NO. REM	RATE	% JUS
27-32-130-011			COMPUTER. ATUDE AND STALL WARNG				(CONTINUED) P/N: 60R40047-()													
A	73	1	57296	0	0.0		L	73	2	83280	2	0.0240		Z	CUM		154577	16	0.1035	
A	CUM		329120	43	0.1307		L	74	2	115348	12	0.1040		ZA	73	1	59928	5	0.0834	
D	73	1	30887	5	0.1619		L	75	2	142112	14	0.0985		ZA	74	1	26583	9	0.3386	
D	74	1	23604	0	0.0		L	76	2	161874	13	0.0803		ZA	75	1	26728	2	0.0748	
D	CUM		54491	5	0.0918		L	CUM		535546	43	0.0803		ZA	76	1	28259	1	0.0354	
H	70	1	5405	0	0.0		R	71	1	10511	0	0.0		ZA	CUM		141498	17	0.1201	
H	71	1	17065	2	0.1172	100	R	72	1	26816	2	0.0746		ZB	75	1	105138	4	0.0380	
H	72	1	32366	2	0.0618		R	73	1	27214	2	0.0735		ZB	76	1	106947	4	0.0374	
H	73	1	43607	1	0.0229		R	74	1	27531	3	0.1090		ZB	CUM		212085	8	0.0377	
H	74	1	57550	4	0.0695		R	75	1	28841	10	0.3467		ZD	76	1	46956	1	0.0213	
H	75	1	75640	4	0.0529		R	CUM		120913	17	0.1406		ZD	CUM		46956	1	0.0213	
H	76	1	80749	5	0.0619		S	71	1	6039	0	0.0		ALL	70		67153	21	0.3127	
H	CUM		312382	18	0.0576		S	CUM		6039	0	0.0		ALL	71		199028	23	0.1156	
J	70	1	6648	2	0.3008		T	72	1	8331	2	0.2401		ALL	72		248652	21	0.0845	
J	71	1	33791	5	0.1480		T	73	1	8549	1	0.1170		ALL	73		393135	29	0.0738	
J	72	1	47849	4	0.0836		T	CUM		16880	3	0.1777		ALL	74		340735	46	0.1350	
J	73	1	61540	11	0.1787		Z	71	1	1812	0	0.0		ALL	75		472871	43	0.0909	
J	74	1	58440	15	0.2567		Z	72	1	13444	1	0.0744		ALL	76		528029	41	0.0776	
J	75	1	53618	3	0.0560		Z	73	1	20834	2	0.0960		ALL	CUM		2249603	224	0.0996	60
27-32-460-011			SENSOR. A/SWG ANGLE OF ATTACK				P/N: 10-60878													
A	70	1	55100	2	0.0363		R	72	1	26816	1	0.0373		ZA	75	1	26728	1	0.0374	
A	71	1	96878	1	0.0103		R	73	1	27214	1	0.0367		ZA	76	1	28259	1	0.0354	
A	72	1	119846	10	0.0834		R	74	1	27531	2	0.0726		ZA	CUM		283778	9	0.0317	
A	73	1	57296	0	0.0		R	75	1	28841	5	0.1734		ZB	70	1	24018	0	0.0	
A	CUM		329120	13	0.0395		R	CUM		120913	9	0.0744		ZB	71	1	48943	2	0.0409	
H	70	1	5405	0	0.0		S	71	1	6039	0	0.0		ZB	72	1	81183	4	0.0493	
H	71	1	17065	0	0.0		S	CUM		6039	0	0.0		ZB	73	1	101418	1	0.0099	
H	72	1	32366	1	0.0309		T	71	1	3385	0	0.0		ZB	74	1	107193	0	0.0	
H	73	1	43607	3	0.0688		T	72	1	8331	1	0.1200		ZB	75	1	105138	6	0.0571	
H	74	1	57550	2	0.0348		T	CUM		11716	1	0.0854		ZB	76	1	106947	7	0.0655	
H	75	1	75640	3	0.0397		Z	73	1	20834	2	0.0960		ZB	CUM		574840	20	0.0348	
H	76	1	80749	4	0.0495		Z	74	1	31679	2	0.0631		ALL	70		101578	2	0.0197	
H	CUM		312382	13	0.0416		Z	75	1	40794	4	0.0981		ALL	71		279455	5	0.0179	
L	71	2	32932	2	0.0607		Z	76	1	46014	4	0.0869		ALL	72		330065	19	0.0576	
L	73	2	83280	1	0.0120		Z	CUM		139321	12	0.0861		ALL	73		393577	11	0.0279	
L	74	2	115348	6	0.0520		ZA	70	1	17055	0	0.0		ALL	74		365884	14	0.0383	
L	75	2	142112	2	0.0141		ZA	71	1	63702	0	0.0		ALL	75		419253	21	0.0501	
L	76	2	161874	2	0.0124		ZA	72	1	61523	2	0.0325		ALL	76		423843	18	0.0425	
L	CUM		535546	13	0.0243		ZA	73	1	59928	3	0.0501		ALL	CUM		2313655	90	0.0389	
R	71	1	10511	0	0.0		ZA	74	1	26583	2	0.0752								

B-15

747 COMPONENT REMOVAL DATA

OP	YR	QPA	UNIT HOURS	NO. REM	RATE	Z JUS	OP	YR	QPA	UNIT HOURS	NO. REM	RATE	Z JUS	OP	YR	QPA	UNIT HOURS	NO. REM	RATE	Z JUS	
27-32-471-011 SHAKER, ATUDE/STALL WARNG CNTCL							P/N: C-07202														
A	70	2	110200	0	0.0		R	71	1	10511	0	0.0		ZA	73	1	59928	0	0.0		
A	71	2	193756	3	0.0155		R	72	1	26816	0	0.0		ZA	74	1	26583	0	0.0		
A	72	2	239692	2	0.0083		R	73	1	27214	0	0.0		ZA	CUM		228791	1	0.0044		
A	73	2	114592	0	0.0		R	74	1	27531	0	0.0		ZB	73	1	101418	1	0.0099		
A	CUM		658240	5	0.0076		R	CUM		92072	0	0.0		ZB	CUM		101418	1	0.0099		
D	74	1	23604	1	0.0424		Z	73	1	20834	0	0.0		ALL	70		127255	0	0.0		
D	CUM		23604	1	0.0424		Z	74	1	31679	1	0.0316		ALL	71		300901	4	0.0133		
L	71	2	32932	0	0.0		Z	CUM		52513	1	0.0190		ALL	72		328031	2	0.0061		
L	73	2	83280	0	0.0		ZA	70	1	17055	0	0.0		ALL	73		407266	1	0.0025		
L	74	2	115348	0	0.0		ZA	71	1	63702	1	0.0157		ALL	74		224745	2	0.0089		
L	CUM		231560	0	0.0		ZA	72	1	61523	0	0.0		ALL	CUM		1388198	9	0.0065		
27-35-130-041 COMPUTER, OVER-ROTN WARNG							P/N: 60840047-()														
A	70	1	55100	6	0.1089		L	73	1	41640	1	0.0240		Z	CUM		154577	13	0.0841		
A	71	1	96878	11	0.1135		L	74	1	57674	7	0.1214		ZA	70	1	17055	0	0.0		
A	72	1	119846	12	0.1001		L	75	1	71056	2	0.0281		ZA	71	1	63702	3	0.0471		
A	73	1	57296	3	0.0524		L	76	1	80937	1	0.0124		ZA	72	1	61523	8	0.1300		
A	CUM		329120	32	0.0972		L	CUM		267773	11	0.0411		ZA	73	1	59928	11	0.1836		
D	73	1	30887	4	0.1295		R	71	1	10511	1	0.0951		ZA	74	1	26583	0	0.0		
D	74	1	23604	0	0.0		R	72	1	26816	3	0.1119		ZA	75	1	26728	1	0.0374		
D	CUM		54491	4	0.0734		R	73	1	27214	5	0.1837		ZA	76	1	28259	1	0.0354		
H	71	1	17065	1	0.0586		R	74	1	27531	1	0.0363		ZA	CUM		283778	24	0.0846		
H	72	1	32366	2	0.0618		R	75	1	28841	3	0.1040		ZB	75	1	105138	6	0.0571		
H	73	1	43607	1	0.0229		R	CUM		120913	13	0.1075		ZB	76	1	106947	4	0.0374		
H	74	1	57550	5	0.0869		S	71	1	6039	1	0.1656		ZB	CUM		212085	10	0.0472		
H	75	1	75640	8	0.1058	70	S	CUM		6039	1	0.1656		ZD	76	1	46956	1	0.0213		
H	76	1	80749	4	0.0495	75	T	71	1	3385	0	0.0		ZD	CUM		46956	1	0.0213		
H	CUM		306977	21	0.0684		T	72	1	8331	1	0.1200		ALL	70		78803	9	0.1142		
J	70	1	6648	3	0.4513		T	73	1	8549	0	0.0		ALL	71		249649	22	0.0881		
J	71	1	33791	5	0.1480		T	74	1	7493	2	0.2669		ALL	72		310175	30	0.0967		
J	72	1	47849	3	0.0627		T	CUM		27758	3	0.1081		ALL	73		351495	42	0.1195		
J	73	1	61540	12	0.1950		Z	71	1	1812	0	0.0		ALL	74		290554	25	0.0860		
J	74	1	58440	8	0.1369		Z	72	1	13444	1	0.0744		ALL	75		401815	30	0.0747		
J	75	1	53618	7	0.1306		Z	73	1	20834	5	0.2400		ALL	76		447092	18	0.0403		
J	76	1	57230	5	0.0874	40	Z	74	1	31679	2	0.0631		ALL	CUM		2129583	176	0.0826	62	
J	CUM		319116	43	0.1347		Z	75	1	40794	3	0.0735									
L	71	1	16466	0	0.0		Z	76	1	46014	2	0.0435									
27-41-006-011 STAB TRIM AUX CONTL ACCUMULATOR							P/N: 65880196														
B	73	1	63517	3	0.0472		Z	74	1	31679	0	0.0		ZA	CUM		141498	9	0.0636		
B	CUM		63517	3	0.0472		Z	75	1	40794	0	0.0		ZB	75	1	105138	0	0.0		
L	73	1	41640	0	0.0		Z	76	1	46014	0	0.0		ZB	CUM		105138	0	0.0		
L	74	1	57674	0	0.0		Z	CUM		139321	0	0.0		ALL	73		185919	5	0.0269		

(CONTINUED ON NEXT PAGE)

747 COMPONENT REMOVAL DATA

OP	YR	OPA	UNIT HOURS	NO. REM	RATE	% JUS	OP	YR	OPA	UNIT HOURS	NO. REM	RATE	% JUS	OP	YR	OPA	UNIT HOURS	NO. REM	RATE	% JUS
27-41-006-011 STAB TRIM AUX CONTL ACCUMULATOR (CONTINUED) P/N: 65880196																				
L	75	1	71056	0	0.0		ZA	73	1	59928	2	0.0334		ALL	74		115936	5	0.0431	
L	76	1	80937	3	0.0371		ZA	74	1	26583	5	0.1881		ALL	75		243716	1	0.0041	
L	CUM		251307	3	0.0119		ZA	75	1	26728	1	0.0374		ALL	76		155210	4	0.0258	
Z	73	1	20834	0	0.0		ZA	76	1	28259	1	0.0354		ALL	CUM		700781	15	0.0214	
27-41-072-081 BRAKE, HORZL STBLR CONT HYD P/N: 60B80028																				
A	70	2	110200	0	0.0		J	70	2	13296	0	0.0		Z	72	2	26888	0	0.0	
A	71	2	193756	1	0.0052		J	71	2	21022	0	0.0		Z	73	2	41668	0	0.0	
A	72	2	239692	0	0.0		J	72	2	95698	0	0.0		Z	74	2	63358	0	0.0	
A	73	2	114592	0	0.0		J	73	2	123080	0	0.0		Z	CUM		135538	0	0.0	
A	CUM		658240	1	0.0015		J	74	2	116880	0	0.0		ZA	70	2	34110	0	0.0	
B	70	2	23764	0	0.0		J	CUM		369976	0	0.0		ZA	71	2	127404	0	0.0	
B	71	2	121028	0	0.0		L	71	2	32932	0	0.0		ZA	72	2	123046	0	0.0	
B	72	2	143226	2	0.0140		L	73	2	83280	0	0.0		ZA	73	2	119856	0	0.0	
B	73	2	127034	2	0.0157		L	74	2	115348	0	0.0		ZA	74	2	53166	0	0.0	
B	74	2	121224	0	0.0		L	CUM		231560	0	0.0		ZA	CUM		457582	0	0.0	
B	CUM		536276	4	0.0075		R	72	2	53632	0	0.0		ALL	70		192180	0	0.0	
H	70	2	10810	0	0.0		R	73	2	54428	0	0.0		ALL	71		545974	1	0.0018	
H	71	2	34130	0	0.0		R	74	2	55062	0	0.0		ALL	72		746914	2	0.0027	
H	72	2	64732	0	0.0		R	CUM		163122	0	0.0		ALL	73		751152	2	0.0027	
H	73	2	87214	0	0.0		S	71	2	12078	0	0.0		ALL	74		640138	0	0.0	
H	74	2	115100	0	0.0		S	CUM		12078	0	0.0		ALL	CUM		2876358	5	0.0017	
H	CUM		311986	0	0.0		Z	71	2	3624	0	0.0								
27-41-344-091 MUTQR, HORZL STBLR TRIM HYD P/N: 60B00250																				
A	70	2	110200	0	0.0		J	71	2	67582	2	0.0296		ZA	70	2	34110	0	0.0	
A	71	2	193756	1	0.0052		J	72	2	95698	4	0.0418		ZA	71	2	127404	0	0.0	
A	72	2	239692	2	0.0083		J	CUM		176576	6	0.0340		ZA	72	2	123046	2	0.0163	
A	CUM		543648	3	0.0055		L	71	2	32932	0	0.0		ZA	CUM		284560	2	0.0070	
B	70	2	23764	0	0.0		L	CUM		32932	0	0.0		ZB	70	2	48036	0	0.0	
B	71	2	121028	0	0.0		R	71	2	21022	1	0.0476		ZB	71	2	97886	0	0.0	
B	72	2	143226	20	0.1396		R	72	2	53632	0	0.0		ZB	72	2	162366	6	0.0370	
B	CUM		288018	20	0.0694		R	CUM		74654	1	0.0134		ZS	CUM		308288	6	0.0195	
H	70	2	10810	0	0.0		S	71	2	12078	0	0.0		ALL	70		240216	0	0.0	
H	71	2	34130	0	0.0		S	CUM		12078	0	0.0		ALL	71		711442	4	0.0056	
H	72	2	64732	0	0.0		Z	71	2	3624	0	0.0		ALL	72		909280	34	0.0374	
H	CUM		105672	0	0.0		Z	72	2	26888	0	0.0		ALL	CUM		1860938	38	0.0204	
J	70	2	13296	0	0.0		Z	CUM		30512	0	0.0								

B-17

B-18

747 COMPONENT REMOVAL DATA

OP	YR	OPA	UNIT HOURS	NO. REM	RATE	% JUS	OP	YR	OPA	UNIT HOURS	NO. REM	RATE	% JUS	OP	YR	OPA	UNIT HOURS	NO. REM	RATE	% JUS	
27-41-402-021 PUMP, HORZL STBLR TRIM STBY HYD							P/N: A0643-0890														
A	70	1	55100	1	0.0181		J	76	1	57230	4	0.0699		Z	75	1	40794	0	0.0		
A	71	1	96878	9	0.0929		J	CUM		319116	15	0.0470		Z	76	1	46014	0	0.0		
A	72	1	119840	1	0.0083		L	71	1	16466	0	0.0		Z	CUM		154577	0	0.0		
A	73	1	57296	2	0.0349		L	72	1	44306	0	0.0		ZA	70	1	17055	0	0.0		
A	CUM		329120	13	0.0395		L	73	1	41640	0	0.0		ZA	71	1	63702	0	0.0		
B	70	1	11882	0	0.0		L	74	1	57674	1	0.0173		ZA	72	1	61523	0	0.0		
B	71	1	60514	2	0.0331		L	75	1	71056	1	0.0141		ZA	75	1	26728	0	0.0		
B	72	1	71613	0	0.0		L	76	1	80937	3	0.0371		ZA	76	1	28259	1	0.0354		
B	73	1	63517	2	0.0315		L	CUM		312079	5	0.0160		ZA	CUM		197267	1	0.0051		
B	75	1	49413	1	0.0202		R	71	1	10511	0	0.0		ZB	73	1	101418	0	0.0		
B	76	1	38378	1	0.0261		R	72	1	26816	2	0.0746		ZB	74	1	107193	0	0.0		
B	CUM		295317	6	0.0203		R	73	1	27214	0	0.0		ZB	75	1	105138	0	0.0		
H	70	1	5405	0	0.0		R	74	1	27531	1	0.0363		ZB	CUM		313749	0	0.0		
H	71	1	17065	1	0.0586		R	75	1	24841	1	0.0347		ZD	76	1	46956	0	0.0		
H	72	1	32366	0	0.0		R	CUM		120913	4	0.0331		ZD	CUM		46956	0	0.0		
H	73	1	43607	1	0.0229		S	71	1	6039	0	0.0		ALL	70		96090	1	0.0104		
H	74	1	57550	0	0.0		S	72	1	9512	0	0.0		ALL	71		310163	14	0.0451		
H	75	1	75640	1	0.0132		S	CUM		15551	0	0.0		ALL	72		435606	5	0.0115		
H	CUM		231633	3	0.0130		T	71	1	3385	0	0.0		ALL	73		417066	6	0.0144		
J	70	1	6648	0	0.0		T	72	1	8331	0	0.0		ALL	74		340067	5	0.0147		
J	71	1	33791	2	0.0592		T	CUM		11716	0	0.0		ALL	75		451228	7	0.0155		
J	72	1	47849	2	0.0418		Z	71	1	1812	0	0.0		ALL	76		297774	9	0.0302		
J	73	1	61540	1	0.0162		Z	72	1	13444	0	0.0		ALL	CUM		2347994	47	0.0200		
J	74	1	58440	3	0.0513		Z	73	1	20834	0	0.0									
J	75	1	53618	3	0.0560		Z	74	1	31679	0	0.0									
27-41-576-771 VALVE, AUX MOD/U MONTD PRES CONT							P/N: 69-14217-2														
B	72	1	71613	0	0.0		J	CUM		149828	0	0.0		ALL	70		6648	0	0.0		
B	73	1	63517	0	0.0		L	71	1	16466	0	0.0		ALL	71		50257	0	0.0		
B	74	1	60612	0	0.0		L	72	1	44306	0	0.0		ALL	72		163768	0	0.0		
B	CUM		195742	0	0.0		L	73	1	41640	0	0.0		ALL	73		166697	0	0.0		
J	70	1	6648	0	0.0		L	74	1	57674	0	0.0		ALL	74		145817	1	0.0069		
J	71	1	33791	0	0.0		L	CUM		160086	0	0.0		ALL	CUM		533187	1	0.0019		
J	72	1	47849	0	0.0		R	74	1	27531	1	0.0363									
J	73	1	61540	0	0.0		R	CUM		27531	1	0.0363									
27-41-576-781 VALVE, HORZL STBTR MOD/U S/O							P/N: 60800207														
D	73	2	61774	2	0.0324		R	71	2	21022	0	0.0		Z	72	2	26888	0	0.0		
D	74	2	47208	1	0.0212		R	72	2	53632	0	0.0		Z	CUM		30512	0	0.0		
D	CUM		108982	3	0.0275		R	73	2	54428	0	0.0		ALL	70		13296	0	0.0		
J	70	2	13296	0	0.0		R	74	2	55062	0	0.0		ALL	71		104306	0	0.0		
J	71	2	67582	0	0.0		R	CUM		184144	0	0.0		ALL	72		195242	0	0.0		
J	72	2	95698	0	0.0		S	71	2	12078	0	0.0		ALL	73		239282	3	0.0125		

(CONTINUED ON NEXT PAGE)

B-19

747 COMPONENT REMOVAL DATA

OP	YR	QPA	UNIT HOURS	NO. REM	RATE	% JJS	OP	YR	QPA	UNIT HOURS	NO. REM	RATE	% JUS	OP	YR	QPA	UNIT HOURS	NO. REM	RATE	% JUS	
27-41-576-781 VALVE, HORZL STBTR MOD/U S/D							(CONTINUED) P/N: 60800207														
J	73	2	123080	1	0.0081		S	72	2	19024	0	0.0		ALL	74		219150	2	0.0091		
J	74	2	116880	1	0.0086		S	CUM		31102	0	0.0		ALL	CUM		771276	5	0.0065		
J	CUM		416536	2	0.0048		Z	71	2	3624	0	0.0									
27-41-681-011 DRI/M, HORZL STBLR TRIM CONTROL							P/N: 65880562														
A	70	1	55100	0	0.0		J	73	1	61540	0	0.0		ZA	72	1	61523	0	0.0		
A	71	1	96878	1	0.0103		J	74	1	58440	0	0.0		ZA	73	1	59928	0	0.0		
A	72	1	119846	0	0.0		J	CUM		208268	0	0.0		ZA	74	1	26583	0	0.0		
A	73	1	57296	0	0.0		L	71	1	16466	0	0.0		ZA	CUM		228791	0	0.0		
A	CUM		329120	1	0.0030		L	73	1	41640	0	0.0		ZB	70	1	24018	0	0.0		
B	73	1	63517	0	0.0		L	74	1	57674	0	0.0		ZB	71	1	48943	0	0.0		
B	74	1	60612	0	0.0		L	CUM		115780	0	0.0		ZB	72	1	81183	0	0.0		
B	CUM		124129	0	0.0		R	73	1	27214	0	0.0		ZB	73	1	101418	0	0.0		
H	70	1	5405	0	0.0		R	74	1	27531	0	0.0		ZB	74	1	107193	0	0.0		
H	71	1	17065	0	0.0		R	CUM		54745	0	0.0		ZB	CUM		362755	0	0.0		
H	72	1	32366	0	0.0		Z	71	1	1812	0	0.0		ALL	70		108226	0	0.0		
H	73	1	43607	0	0.0		Z	72	1	13444	0	0.0		ALL	71		278657	1	0.0036		
H	74	1	57550	0	0.0		Z	73	1	20834	0	0.0		ALL	72		356211	0	0.0		
H	CUM		155993	0	0.0		Z	74	1	31679	0	0.0		ALL	73		476994	0	0.0		
J	70	1	6648	0	0.0		Z	CUM		67769	0	0.0		ALL	74		427262	0	0.0		
J	71	1	33791	0	0.0		ZA	70	1	17055	0	0.0		ALL	CUM		1647350	1	0.0006		
J	72	1	47849	0	0.0		ZA	71	1	63702	0	0.0									
27-41-687-081 MOD/U, HOSTB STBY HYD POWER S/D							P/N: 60800241-1														
A	72	1	119846	0	0.0		J	71	1	33791	0	0.0		T	71	1	3385	0	0.0		
A	73	1	57296	0	0.0		J	72	1	47849	0	0.0		T	72	1	8331	0	0.0		
A	CUM		177142	0	0.0		J	73	1	61540	0	0.0		T	CUM		11716	0	0.0		
B	70	1	11882	0	0.0		J	74	1	58440	1	0.0171		Z	71	1	1812	0	0.0		
B	71	1	60514	0	0.0		J	CUM		208268	1	0.0048		Z	72	1	13444	0	0.0		
B	72	1	71613	0	0.0		L	73	1	41640	0	0.0		Z	73	1	20834	0	0.0		
B	73	1	63517	0	0.0		L	74	1	57674	0	0.0		Z	CUM		36090	0	0.0		
B	74	1	60612	0	0.0		L	CUM		99314	0	0.0		ZA	73	1	59928	1	0.0167		
B	CUM		268138	0	0.0		R	71	1	10511	0	0.0		ZA	74	1	26583	2	0.0752		
H	70	1	5405	0	0.0		R	72	1	26816	0	0.0		ZA	CUM		86511	3	0.0347		
H	71	1	17065	0	0.0		R	73	1	27214	0	0.0		ALL	70		23935	0	0.0		
H	72	1	32366	0	0.0		R	74	1	27531	0	0.0		ALL	71		133117	0	0.0		
H	73	1	43607	0	0.0		R	CUM		92072	0	0.0		ALL	72		329777	0	0.0		
H	74	1	57550	0	0.0		S	71	1	6039	0	0.0		ALL	73		375576	1	0.0027		
H	CUM		155993	0	0.0		S	72	1	9512	0	0.0		ALL	74		288390	3	0.0104		
J	70	1	6648	0	0.0		S	CUM		15551	0	0.0		ALL	CUM		1150795	4	0.0035		

747 COMPONENT REMOVAL DATA

OP	YR	OPA	UNIT HOURS	NO. REM	RATE	% JUS	OP	YK	OPA	UNIT HOURS	NO. REM	RATE	% JUS	OP	YR	OPA	UNIT HOURS	NO. REM	RATE	% JUS
27-41-687-101							MOD/U. HORZL STBLR TRIM CONT							P/N: 60880027-()						
A	70	2	110200	3	0.0272		J	75	2	107236	1	0.0093		ZA	70	2	34110	0	0.0	
A	71	2	193756	20	0.1032		J	76	2	114460	2	0.0175		ZA	71	2	127404	3	0.0235	
A	72	2	235692	7	0.0292		J	CUM		638232	9	0.0141		ZA	72	2	123046	2	0.0163	
A	73	2	114592	0	0.0		L	71	2	32932	0	0.0		ZA	73	2	119856	6	0.0501	
A	CUM		658240	30	0.0456		L	73	2	83280	0	0.0		ZA	74	2	53166	8	0.1505	
B	70	2	23764	0	0.0		L	74	2	115348	2	0.0173		ZA	75	2	53456	0	0.0	
B	71	2	121028	0	0.0		L	75	2	142112	11	0.0774		ZA	76	2	56518	3	0.0531	
B	72	2	143226	0	0.0		L	76	2	161874	17	0.1050		ZA	CUM		567556	22	0.0388	
B	73	2	127034	1	0.0079		L	CUM		535546	30	0.0560		ZB	70	2	48036	3	0.0625	
B	74	2	121224	2	0.0165		R	71	2	21022	0	0.0		ZB	71	2	97886	8	0.0817	
B	75	2	98826	6	0.0607		R	72	2	53632	3	0.0559		ZB	72	2	162366	12	0.0739	
B	76	2	76756	1	0.0130		R	73	2	54428	1	0.0184		ZB	73	2	202836	6	0.0296	
B	CUM		711858	10	0.0140		R	74	2	55062	0	0.0		ZB	74	2	214386	5	0.0233	
H	70	2	10810	1	0.0925	100	R	75	2	57682	0	0.0		ZB	75	2	210276	6	0.0285	
H	71	2	34130	2	0.0586		R	CUM		241826	4	0.0165		ZB	76	2	213894	8	0.0374	
H	72	2	64732	1	0.0154		S	71	2	12078	0	0.0		ZB	CUM		1149680	48	0.0418	
H	73	2	87214	0	0.0		S	CUM		12078	0	0.0		ZD	76	2	93912	0	0.0	
H	74	2	115100	0	0.0		T	71	2	6770	1	0.1477		ZD	CUM		93912	0	0.0	
H	75	2	151280	1	0.0066		T	CUM		6770	1	0.1477		ALL	70		240216	8	0.0333	
H	76	2	161498	0	0.0		Z	71	2	3624	0	0.0		ALL	71		718212	35	0.0487	
H	CUM		624764	5	0.0080		Z	72	2	26888	0	0.0		ALL	72		909280	27	0.0297	
J	70	2	13296	1	0.0752		Z	73	2	41668	0	0.0		ALL	73		953988	15	0.0157	
J	71	2	67582	1	0.0148		Z	74	2	63358	0	0.0		ALL	74		854524	18	0.0211	
J	72	2	95698	2	0.0209		Z	75	2	81588	0	0.0		ALL	75		902456	25	0.0277	
J	73	2	123080	1	0.0081		Z	76	2	92028	0	0.0		ALL	76		970940	31	0.0319	
J	74	2	116880	1	0.0086		Z	CUM		309154	0	0.0		ALL	CUM		5549616	159	0.0287	100

27-60-404-181 QUADRANT, SPLR/SPBRK HANDL BRAKE

P/N: 50196

A	71	1	96878	0	0.0		J	70	1	6648	0	0.0		ZA	71	1	63702	0	0.0	
A	72	1	119846	1	0.0083		J	71	1	33791	0	0.0		ZA	72	1	61523	0	0.0	
A	73	1	57296	0	0.0		J	72	1	47849	0	0.0		ZA	73	1	59928	0	0.0	
A	CUM		274020	1	0.0036		J	73	1	61540	0	0.0		ZA	74	1	26583	0	0.0	
B	70	1	11882	0	0.0		J	74	1	58440	0	0.0		ZA	CUM		228791	0	0.0	

(CONTINUED ON NEXT PAGE)

747 COMPONENT REMOVAL DATA

DP	YR	OPA	UNIT HOURS	NO. REM	RATE	% JUS	DP	YR	OPA	UNIT HOURS	NO. REM	RATE	% JUS	DP	YR	OPA	UNIT HOURS	NO. REM	RATE	% JUS
27-60-404-181 QUADRANT, SPLR/SPBRK HANDL BRAKE (CONTINUED) P/N: 50196																				
B	71	1	60514	0	0.0		J	CUM		208268	0	0.0		ZB	73	1	101418	0	0.0	
B	72	1	71613	0	0.0		L	71	1	16466	0	0.0		ZB	74	1	107193	0	0.0	
B	73	1	63517	0	0.0		L	73	1	41640	0	0.0		ZB	CUM		208611	0	0.0	
B	74	1	60612	0	0.0		L	74	1	57674	4	0.0694		ALL	70		40990	0	0.0	
B	CUM		268138	0	0.0		L	CUM		115780	4	0.0345		ALL	71		290228	0	0.0	
H	70	1	5405	0	0.0		Z	71	1	1812	0	0.0		ALL	72		346641	1	0.0029	
H	71	1	17065	0	0.0		Z	72	1	13444	0	0.0		ALL	73		449780	0	0.0	
H	72	1	32366	0	0.0		Z	73	1	20834	0	0.0		ALL	74		399731	4	0.0100	
H	73	1	43607	0	0.0		Z	74	1	31679	0	0.0		ALL	CUM		1527370	5	0.0033	
H	74	1	57550	0	0.0		Z	CUM		67769	0	0.0								
H	CUM		155993	0	0.0		ZA	70	1	17055	0	0.0								
27-60-659-021 DIFFERENTIAL, FC SPLR/SPBRK P/N: 65880836																				
A	70	2	110200	0	0.0		L	73	2	83280	0	0.0		Z	CUM		135538	0	0.0	
A	71	2	193756	0	0.0		L	74	2	115348	0	0.0		ZA	70	2	34110	0	0.0	
A	72	2	239692	0	0.0		L	CUM		231560	0	0.0		ZA	71	2	127404	0	0.0	
A	73	2	114592	0	0.0		R	71	2	21022	0	0.0		ZA	72	2	123046	0	0.0	
A	CUM		658240	0	0.0		R	72	2	53632	0	0.0		ZA	73	2	119856	0	0.0	
B	70	2	23764	0	0.0		R	73	2	54428	0	0.0		ZA	74	2	53166	0	0.0	
B	71	2	121028	0	0.0		R	74	2	55062	0	0.0		ZA	CUM		457582	0	0.0	
B	72	2	143226	0	0.0		R	CUM		184144	0	0.0		ZB	73	2	202836	0	0.0	
B	73	2	127034	0	0.0		S	71	2	12078	0	0.0		ZB	74	2	214386	0	0.0	
B	74	2	121224	0	0.0		S	72	2	19024	0	0.0		ZB	CUM		417222	0	0.0	
B	CUM		536276	0	0.0		S	CUM		31102	0	0.0		ALL	70		181370	0	0.0	
J	70	2	13296	0	0.0		T	71	2	6770	0	0.0		ALL	71		586196	0	0.0	
J	71	2	67582	0	0.0		T	72	2	16662	0	0.0		ALL	72		717868	0	0.0	
J	72	2	95698	0	0.0		T	CUM		23432	0	0.0		ALL	73		866774	0	0.0	
J	73	2	123080	0	0.0		Z	71	2	3624	0	0.0		ALL	74		739424	0	0.0	
J	74	2	116880	0	0.0		Z	72	2	26888	0	0.0		ALL	CUM		3091632	0	0.0	
J	CUM		416536	0	0.0		Z	73	2	41668	0	0.0								
L	71	2	32932	0	0.0		Z	74	2	63358	0	0.0								
27-60-697-011 SEQ/M, FLIGHT CONT SPOILER/SPBRK P/N: 65880859																				
A	70	1	55100	0	0.0		J	73	1	61540	0	0.0		Z	73	1	20834	0	0.0	
A	71	1	96878	0	0.0		J	74	1	58440	0	0.0		Z	74	1	31679	0	0.0	
A	72	1	119846	0	0.0		J	CUM		208268	1	0.0048		Z	CUM		67769	0	0.0	
A	73	1	57296	0	0.0		L	71	1	16466	0	0.0		ZA	70	1	17055	0	0.0	
A	CUM		329120	0	0.0		L	73	1	41640	1	0.0240		ZA	71	1	63702	0	0.0	
B	70	1	11882	0	0.0		L	74	1	57674	0	0.0		ZA	72	1	61523	0	0.0	
B	71	1	60514	0	0.0		L	CUM		115780	1	0.0086		ZA	73	1	59928	0	0.0	
B	72	1	71613	0	0.0		R	71	1	10511	0	0.0		ZA	74	1	26583	0	0.0	
B	73	1	63517	0	0.0		R	72	1	26816	0	0.0		ZA	CUM		228791	0	0.0	
B	74	1	60612	0	0.0		R	73	1	27214	0	0.0		ZB	73	1	101418	0	0.0	

(CONTINUED ON NEXT PAGE)

B-23

747 COMPONENT REMOVAL DATA

OP	YR	OPA	UNIT HOURS	NO. REM	RATE	% JUS	OP	YR	OPA	UNIT HOURS	NO. REM	RATE	% JUS	OP	YR	OPA	UNIT HOURS	NO. REM	RATE	% JUS	
27-61-675-1612							OUTBD FLIGHT SPOILER PCU							P/N: 60880008-()							
A	70	8	440800	2	0.0045		J	76	8	457840	1	0.0022		ZA	71	8	509616	1	0.0020		
A	71	8	775024	0	0.0		J CUM			2552928	20	0.0078		ZA	72	8	492184	3	0.0061		
A	72	8	958768	0	0.0		L	71	8	131728	1	0.0076		ZA	73	8	479424	2	0.0042		
A	73	8	458368	0	0.0		L	73	8	333120	1	0.0030		ZA	74	8	212664	0	0.0		
A	CUM		2632960	2	0.0008		L	74	8	461392	10	0.0217		ZA	75	8	213824	5	0.0234		
B	70	8	95056	0	0.0		L	75	8	568448	0	0.0		ZA	76	8	226072	1	0.0044		
B	71	8	484112	0	0.0		L CUM			1494688	12	0.0080		ZA CUM			2270224	12	0.0053		
B	72	8	572904	0	0.0		R	71	6	84088	1	0.0119		ZB	70	8	192144	1	0.0052		
B	73	8	508136	0	0.0		R	72	8	214528	4	0.0186		ZB	71	8	391544	3	0.0077		
B	74	8	484896	2	0.0041		R	73	8	217712	3	0.0138		ZB	72	8	649464	8	0.0123		
B	75	8	395304	1	0.0025		R	74	8	220248	3	0.0136		ZB	73	8	811344	8	0.0099		
B	76	8	307024	3	0.0098		R	75	10	288410	6	0.0208		ZB	74	8	857544	36	0.0420		
B	CUM		2847432	6	0.0021		R CUM			1024986	17	0.0166		ZB	75	8	841104	49	0.0583	90	
H	70	8	43240	0	0.0		S	71	8	48312	0	0.0		ZB	76	8	855576	68	0.0795	94	
H	71	8	136520	0	0.0		S	72	8	76096	0	0.0		ZB CUM			4598720	173	0.0376		
H	72	8	258928	1	0.0039		S CUM			124408	0	0.0		ZD	76	8	375648	11	0.0293		
H	73	8	348856	3	0.0086		T	71	8	27080	0	0.0		ZD CUM			375648	11	0.0293		
H	74	8	460400	6	0.0130		T	72	8	66648	0	0.0		ALL	70		960864	4	0.0042		
H	75	8	605120	4	0.0066		T	73	8	68392	0	0.0		ALL	71		2858352	6	0.0021		
H	76	8	645992	9	0.0139		T	74	8	59944	7	0.1168		ALL	72		3672312	21	0.0057		
H	CUM		2499056	23	0.0092		T CUM			222064	7	0.0315		ALL	73		3884344	21	0.0054		
J	70	8	53184	1	0.0188		Z	73	8	166672	0	0.0		ALL	74		3478040	71	0.0204		
J	71	8	270328	0	0.0		Z	74	8	253432	3	0.0118		ALL	75		3667506	73	0.0199		
J	72	8	382792	5	0.0131		Z	75	8	326352	3	0.0092		ALL	76		3236264	109	0.0337		
J	73	8	492320	4	0.0081		Z	76	8	368112	16	0.0435		ALL CUM			21757682	305	0.0140	92	
J	74	8	467520	4	0.0086		Z CUM			1114568	22	0.0197									
J	75	8	428944	5	0.0117		ZA	70	8	136440	0	0.0									
27-62-008-111							ACTUATOR, GROUND SPOILER							P/N: 60880008							
A	70	2	110200	0	0.0		J	75	2	107236	1	0.0093		Z	76	2	92028	0	0.0		
A	71	2	193756	1	0.0052		J	76	2	114460	0	0.0		Z CUM			309154	0	0.0		
A	72	2	239692	1	0.0042		J CUM			638232	5	0.0078		ZA	70	2	34110	0	0.0		
A	73	2	114592	0	0.0		L	71	2	32932	0	0.0		ZA	71	2	127404	2	0.0157		
A	CUM		658240	2	0.0030		L	73	2	83280	0	0.0		ZA	72	2	123046	0	0.0		
B	70	2	23764	0	0.0		L	74	2	115348	2	0.0173		ZA	73	2	119856	3	0.0250		
B	71	2	121028	0	0.0		L	75	2	142112	0	0.0		ZA	74	2	53166	3	0.0564		
B	72	2	143226	0	0.0		L	76	2	161874	1	0.0062		ZA	75	2	53456	1	0.0187		
B	73	2	127034	0	0.0		L CUM			535546	3	0.0056		ZA	76	2	56518	1	0.0177		
B	74	2	121224	0	0.0		R	71	2	21022	0	0.0		ZA CUM			567556	10	0.0176		
B	75	2	98826	1	0.0101		R	72	2	53632	0	0.0		ZB	70	2	48036	0	0.0		
B	76	2	76756	2	0.0261		R	73	2	54428	0	0.0		ZB	71	2	97886	0	0.0		
B	CUM		711858	3	0.0042		R	74	2	55062	2	0.0363		ZB	72	2	162366	8	0.0493		
H	70	2	10810	0	0.0		R	75	2	57682	0	0.0		ZB	73	2	202836	1	0.0049		
H	71	2	34130	0	0.0		R CUM			241826	2	0.0083		ZB	74	2	214386	5	0.0233		

(CONTINUED ON NEXT PAGE)

B-24

747 COMPONENT REMOVAL DATA

OP	YR	OPA	UNIT HOURS	NO. REM	RATE	% JUS	OP	YR	OPA	UNIT HOURS	NO. REM	RATE	% JUS	OP	YR	OPA	UNIT HOURS	NO. REM	RATE	% JUS
27-62-008-111			ACTUATOR, GROUND SPOILER				(CONTINUED) P/N: 60880008													
H	72	2	64732	0	0.0		S	71	2	12078	0	0.0		ZB	75	2	210276	6	0.0285	
H	73	2	87214	0	0.0		S	72	2	19024	0	0.0		ZB	76	2	213894	8	0.0374	
H	74	2	115100	0	0.0		S	CUM		31102	0	0.0		ZB	CUM		1149680	28	0.0244	
H	75	2	151280	0	0.0		T	71	2	6770	0	0.0		ALL	70		240216	0	0.0	
H	76	2	161498	0	0.0		T	72	2	16662	0	0.0		ALL	71		718212	3	0.0042	
H	CUM		624764	0	0.0		T	CUM		23432	0	0.0		ALL	72		944966	9	0.0095	
J	70	2	13296	0	0.0		Z	71	2	3624	0	0.0		ALL	73		953988	6	0.0063	
J	71	2	67582	0	0.0		Z	72	2	26888	0	0.0		ALL	74		854524	14	0.0164	
J	72	2	95698	0	0.0		Z	73	2	41668	0	0.0		ALL	75		902456	9	0.0100	
J	73	2	123080	2	0.0162		Z	74	2	63358	0	0.0		ALL	76		877028	12	0.0137	
J	74	2	116880	2	0.0171		Z	75	2	81588	0	0.0		ALL	CUM		5491390	53	0.0097	
27-62-008-381			LINEAR ACTUATOR, AUTO SPEED BRAKE				P/N: 60880052													
B	70	1	11882	1	0.0842		L	71	1	16466	2	0.1215		Z	CUM		139321	0	0.0	
B	71	1	60514	7	0.1157		L	73	1	41640	1	0.0240		ZA	70	1	17055	0	0.0	
B	72	1	71613	8	0.1117		L	74	1	57674	4	0.0694		ZA	71	1	63702	4	0.0628	
B	73	1	63517	2	0.0315		L	75	1	71056	2	0.0281		ZA	72	1	61523	2	0.0325	
B	74	1	60612	12	0.1980		L	76	1	80937	6	0.0741		ZA	73	1	59928	6	0.1001	
B	75	1	49413	1	0.0202		L	CUM		267773	15	0.0560		ZA	74	1	26583	0	0.0	
B	76	1	38378	3	0.0782		R	71	1	10511	1	0.0951		ZA	75	1	26728	3	0.1122	
B	CUM		355529	34	0.0955		R	72	1	26816	1	0.0373		ZA	76	1	28259	3	0.1062	
H	70	1	5405	0	0.0		R	73	1	27214	0	0.0		ZA	CUM		283778	18	0.0634	
H	71	1	17065	0	0.0		R	74	1	27531	0	0.0		ZB	73	1	101418	0	0.0	
H	72	1	32366	2	0.0618		R	75	1	28841	0	0.0		ZB	74	1	107193	0	0.0	
H	73	1	43607	1	0.0229		R	CUM		120913	2	0.0165		ZB	75	1	105138	2	0.0190	
H	74	1	57550	7	0.1216		S	71	1	6039	0	0.0		ZB	76	1	106947	0	0.0	
H	75	1	75640	1	0.0132		S	72	1	9512	0	0.0		ZB	CUM		420696	2	0.0048	
H	76	1	80749	4	0.0495		S	CUM		15551	0	0.0		ZD	76	1	46956	0	0.0	
H	CUM		312382	15	0.0480		T	71	1	3385	1	0.2954		ZD	CUM		46956	0	0.0	
J	70	1	6648	0	0.0		T	72	1	8331	0	0.0		ALL	70		40990	1	0.0244	
J	71	1	33791	3	0.0888		T	73	1	8549	0	0.0		ALL	71		211473	18	0.0851	
J	72	1	47849	2	0.0418		T	74	1	7493	1	0.1335		ALL	72		258010	15	0.0581	
J	73	1	61540	3	0.0487		T	CUM		27758	2	0.0721		ALL	73		428247	13	0.0304	
J	74	1	58440	0	0.0		Z	73	1	20834	0	0.0		ALL	74		434755	24	0.0552	
J	75	1	53618	2	0.0373		Z	74	1	31679	0	0.0		ALL	75		451228	11	0.0244	
J	76	1	57230	7	0.1223	15	Z	75	1	40794	0	0.0		ALL	76		485470	23	0.0474	
J	CUM		319116	17	0.0533		Z	76	1	46014	0	0.0		ALL	CUM		2310173	105	0.0455	15
27-62-576-461			CONTROL VALVE, GROUND SPOILER				P/N: 60800235													
A	70	1	55100	0	0.0		J	73	1	61540	0	0.0		Z	73	1	20834	0	0.0	
A	71	1	96878	0	0.0		J	74	1	58440	0	0.0		Z	74	1	31679	0	0.0	
A	72	1	119846	0	0.0		J	CUM		208268	0	0.0		Z	CUM		67769	0	0.0	
A	73	1	57296	0	0.0		L	71	1	16466	0	0.0		ZA	70	1	17055	0	0.0	
(CONTINUED ON NEXT PAGE)																				

747 COMPONENT REMOVAL DATA																					
OP	YR	OPA	UNIT HOURS	NO. REM	RATE	% JUS	OP	YR	OPA	UNIT HOURS	NO. REM	RATE	% JUS	OP	YR	OPA	UNIT HOURS	NO. REM	RATE	% JUS	
27-62-576-461			CONTROL VALVE,			GROUND SPOILER			(CONTINUED) P/N: 60800235												
A	CUM		329120	0	0.0		L	73	1	41640	0	0.0		ZA	71	1	63702	0	0.0		
B	70	1	11882	0	0.0		L	74	1	57674	0	0.0		ZA	72	1	61523	0	0.0		
B	71	1	60514	0	0.0		L	CUM		115780	0	0.0		ZA	73	1	59928	2	0.0334		
B	72	1	71613	0	0.0		R	71	1	10511	0	0.0		ZA	74	1	26583	1	0.0376		
B	73	1	63517	1	0.0157		R	72	1	26816	0	0.0		ZA	CUM		228791	3	0.0131		
B	74	1	60612	0	0.0		R	73	1	27214	0	0.0		ZB	73	1	101418	0	0.0		
B	CUM		268138	1	0.0037		R	74	1	27531	0	0.0		ZB	74	1	107193	0	0.0		
H	70	1	5405	0	0.0		R	CUM		92072	0	0.0		ZB	CUM		208611	0	0.0		
H	71	1	17065	0	0.0		S	71	1	6039	0	0.0		ALL	70		96090	0	0.0		
H	72	1	32366	0	0.0		S	72	1	9512	0	0.0		ALL	71		310163	0	0.0		
H	73	1	43607	0	0.0		S	CUM		15551	0	0.0		ALL	72		391300	0	0.0		
H	74	1	57550	0	0.0		T	71	1	3385	0	0.0		ALL	73		476994	3	0.0063		
H	CUM		155993	0	0.0		T	72	1	8331	0	0.0		ALL	74		427262	1	0.0023		
J	70	1	6648	0	0.0		T	CUM		11716	0	0.0		ALL	CUM		1701809	4	0.0024		
J	71	1	33791	0	0.0		Z	71	1	1812	0	0.0									
J	72	1	47849	0	0.0		Z	72	1	13444	0	0.0									

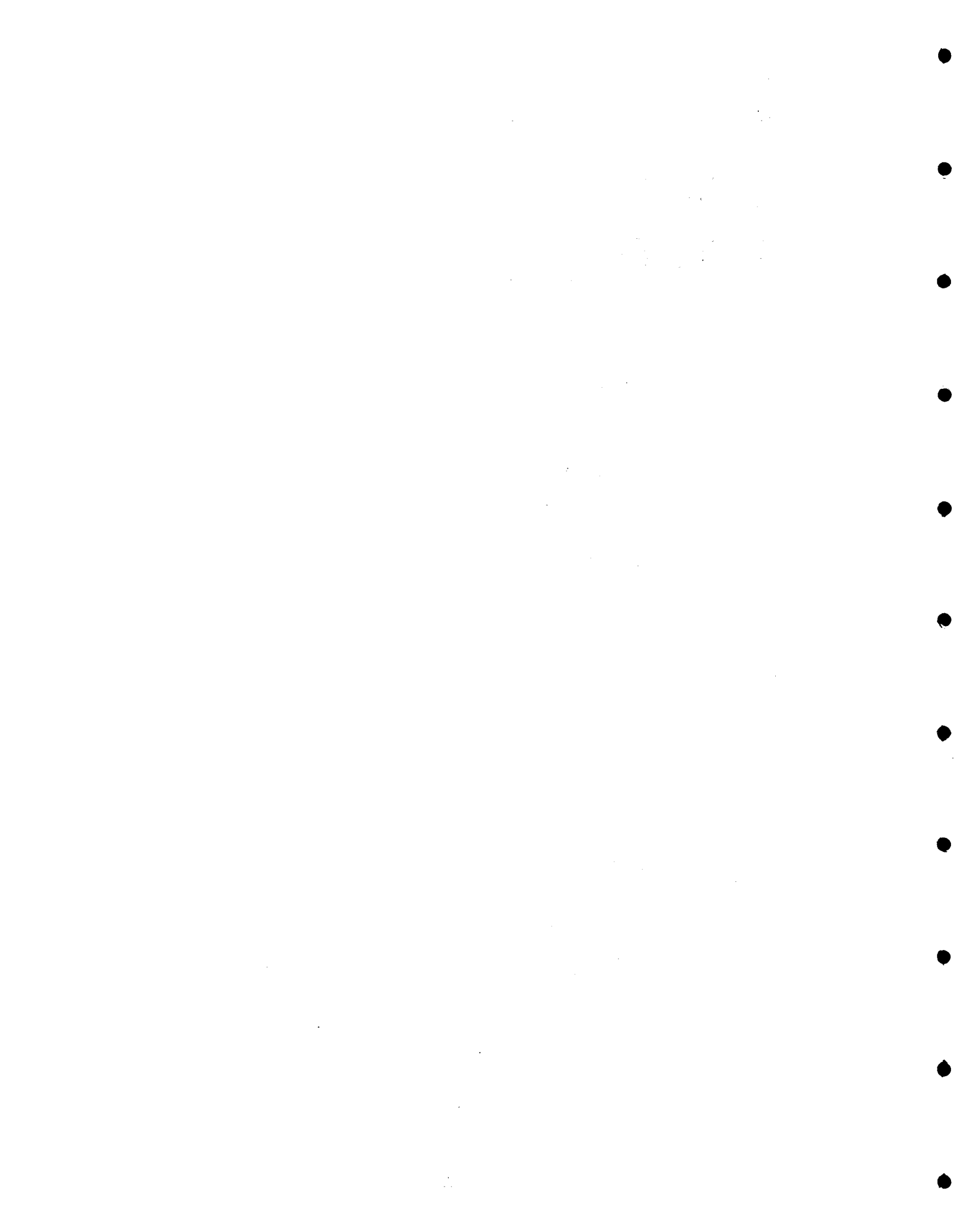

APPENDIX C

POWER CONTROL UNIT WORKSHOP FINDINGS

To derive failure rates for some flight control system modules, used in the reliability analysis, details are required on modes of failure. This appendix includes a history of components that were sent through the component overhaul shops of five airlines. The histories are categorized by types of discrepancies found.

Analysis of shop findings

DISCREPANCY	Defect stated in		ACTIONS TAKEN
	1970-73	1974	
<u>OUTBOARD AILERON PCU</u>			
<u>Exc. internal leakage through:</u>			
- Thermostatic valve	16	14	AEB SN 27-5: removal of thermostatic valve
- Anti-cavitation check valve	2	-	
- Flow control valve	1	-	
Piston head & rod scratched	9	2	Manufacturing problem (isolated case)
Main control valve: dead band out of adjustment	2	-	
Neutral of actuator: out of tolerance	1	2	
Barrel trunnion bore corroded	1	-	
<u>INBOARD AILERON PCU</u>			
<u>Exc. internal leakage through:</u>			
- Thermostatic valve	22	15	AEB SN 27-6: removal of thermostatic valve
- Main control valve	13	9	
- Check valve of aft manifold	1	-	
Piston head and rod scratched	16	9	
Fwd barrel scratched	-	1	
Neutral of actuator : out of adjustment	-	1	
Bearing of aft barrel worn	-	2	
External leakage on center gland back-up ring/packing defective	2	-	

DISCREPANCY	Defect Stated in		ACTIONS TAKEN
	1970-73	1974	
<u>CENTRAL LATERAL PCP</u>			
<u>Excessive intern. leakage through</u>			
- Thermostatic valve	9	-	AEB SN 27-7: Removal of thermostatic valve
- Main control valve	1	4	
- A/P actuator	3	1	
Piston head & rod scratched	6	-	
Pin in housing of MCV	1	-	Material defective
Seepage through wall of main housing	1	-	Material defective
Transducer calibration: out of tolerance	5	3	
Transfer valve: null bias out of tolerance	2	1	
Input lever friction test: out of tolerance	1	1	
A/P override test : out of tol.	4	-	} Hydraulic Research new procedures to improve the adjustments.
A/P detent breakaway : "	1	-	
A/P velocity & threshold: out of tolerance	1	-	
<u>INBOARD ELEVATOR PCU</u>			
<u>Exc. internal leakage through:</u>			
- Thermostatic valve	18	4	AEB SN 27-3: removal of thermostatic valve
- Main Control valve	21	16	
- Compensator check valve	5	2	
- Time delay valve	1		Valve broken, isolated case.
Piston head & rod scratched	8	1	
Piston rod: internal bore corroded	1		New sealing procedures for affected rod
Transfer valve null bias: out of tolerance	4	1	

DISCREPANCY	Defect stated in		ACTIONS TAKEN
	1970-73	1974	
<u>INBOARD ELEVATOR PCU (Cont'd)</u>			
Transducer: out of tolerance	6	13	Bertea new adjustment procedures
A/P actuator: piston & slide scratched	1	-	
A/P override test too high	1	-	Bertea new procedures
Rod end bearing: excessive play	3	-	
Neutral of actuator: out of tol.	1	-	Neutral adjustm. procedures revised
Input arm bearing worn	1	-	
Manifold press line eroded	1	-	Improved fastening of MCV by double torquing method
PCU reaction link brg rod end defective	3	2	
Linkage break out friction test	-	1	
Pillow block: bearing too stiff	-	4	{ - Addition of dry lube on trunnions before bearing installation
External leakage on center gland	1	1	
O'rings of MCV line/guide damaged	2	1	
<u>OUTBOARD ELEVATOR PCU</u>			
<u>Exc. internal leakage through:</u>			
- Thermostatic valve	13	3	AEB SN 27-3: removal of thermostatic valve
- Main control valve	3	2	
Housing distorted/out of tol.	3	-	Defect due to manufacturer internal processing

DISCREPANCIES	Defect stated in		ACTIONS TAKEN
	1970-73	1974	
<u>OUTBOARD ELEVATOR (Cont'd)</u>			
Neutral of actuator: out of tol.	1	-	
Piston head & rod scratched	8	2	
Input rod end bearing worn	1		
<u>RUDDER PCU</u>			
<u>Exc. internal leakage through:</u>			
- Thermostatic valve	19	2	AEB SN 27-4: removal of thermostatic valve
- Main control valve	22	19	
- Transfer valve	6	16	
Rod end bearing loose	15	3	NWL SB.171 - Install. of steel brg.
Piston head & rod scratched	16	15	<u>Action 1975:</u> Dwgs modified to cancel criss cross lapping of piston rod.
Transfer valve null bias: out of tolerance	2	2	
Main Control valve binds in extreme position	1	-	
Neutral of actuator: out of tol.	-	1	
Manual output stroke: snubbing test out of tolerance	-	4	New in-service limits have been obtained from NWL and incorporated in OM.
No load velocity piston check: too low	-	3	Problem related to MCV erosion.
<u>INBOARD SPOILER PCU</u>			
<u>Thermal relief valve</u>			
- Cracking press too low	1		
- Internal leakage	7	7	SB 29300-27-01: installation of improved valve
Rod end bearing loose	5	2	SB 29300-27-01: install. of steel bearing
Step shaped wear of cylinder wall	1	-	

DISCREPANCIES	Defect stated in		ACTIONS TAKEN
	1970-73	1974	
<u>Extension check valve</u>			
- Housing scratched	1	-	
- Ball & cage assy corroded	1	-	
Piston head & rod scratched	1	-	
Hysteresis : out of tolerance	1	-	
Blow down check valve eroded	1	-	
Ext. leakage on actuator shaft: seal defective.	2	-	
Pillow blocks bearing worn	-	1	
<u>OUTBOARD SPOILER PCU</u>			
<u>Exc. internal leakage through:</u>			
- Thermal relief valve	32	28	SB 29310-27-01: Installation of improved valve.
- Main control valve	2	-	
- Blow down check valve	8	7	
- Extension check valve	1	-	
<u>Cracking press too low on:</u>			
- Blow down check valve	1	-	
- Extension check valve	1	-	
Rod end bearing loose	8	8	SB.29310-27-01: Installation of steel bearing.
Piston head & rod scratched	5	3	
Main control valve balance check: out of tolerance	3	1	
Hysteresis : out of tol.	6	-	Input shaft spherical eccentric worn
Lock down capability check: out of tol.	2	1	
Manifold cracked	1	-	Attributed to excessive torque of shuttle valve retainer.

DISCREPANCIES	Defect stated in		ACTIONS TAKEN
	1970-73	1974	
<u>STABILIZER CONTROL MODULE</u>			
<u>Exc. internal leakage through:</u>			
- Solenoid valve(s)	15	4	AEB SN 27-9: installation of an improved hydr. body assy.
- Rate valve	3	-	
- Check valve(s)	5	-	
Arming & control valve spool: seals defective	11	-	AEB 27-57: replacement of capstrips with channel seals
Motor operated shut-off valve defective	4	-	
Diaphragm defective	2	-	
Manual input arming valve force test : out of tolerance	5	-	
Centering piston jammed	1	-	
Flow characteristic: out of tol.	3	-	
Spring arming slide valve too weak	1	-	AEB 27-146: installation of stronger centering spring
Check valve missing on module	1	-	AEB SN 27-16: installation of improved retainer screws
Housing eroded			Housing misdrilled during manufacturing (isolated case)

APPENDIX D

747 HYDRAULIC SYSTEM FLUID LOSSES

The reliability analysis included the effects of power system failures. Power for actuator and control modules is available from 4 hydraulic systems and loss of fluid through line or component breaks will cause power loss. Included in this appendix is a history of 747 hydraulic system fluid losses for 2 airlines from February 1975 to April 1976.

AIRLINE A-747 HYDRAULIC SYSTEM LOSS SUMMARY
February 1975 - April 1976

149,069 FLIGHT HOURS

<u>Registration Number</u>	<u>Date</u>	<u>System Lost</u>	<u>Description</u>
53	2-3-75	#1	#1 EDP L.P. light on, lost hydraulic fluid, used alternate mode to extend landing gear. #1 EDP leak.
70	2-9-75	#1	#1 EDP failed on takeoff, hydraulic quantity dropped, ADP turned off. EDP leaking through case drain.
40	2-12-75	#4	#4 EDP L.P. light on, hydraulic quantity dropped, used alternate mode to extend RH wing landing gear. #4 EDP shaft sheared and filter collapsed.
70	3-2-75	#4	#4 hydraulic system fluid lost, used alternate mode to extend T.E. flaps and wing landing gear. Pump pressure line chafed through and EDP leaking at drive shaft.
50	3-25-75	#4	#4 hydraulic system fluid loss, shutoff ADP and EDP. Hydraulic system return tube leaking.
54	4-2-75	#1	#1 hydraulic system quantity dropped to zero, EDP and ADP off. EDP leaking at parting surface caused by broken bolt.
51	4-10-75	#1	#1 hydraulic system quantity lost on final approach. Right body landing gear downlock actuator cracked.
42	4-22-75	#1	#1 hydraulic system quantity dropped to zero after gear down and locked. Left body landing gear downlock actuator cracked.
40	4-28-75	#1	#1 EDP L.P. light on, hydraulic quantity dropped, depressurized EDP and ADP. Pressure line to pressure filter leaking.
41	5-4-75	#1	#1 hydraulic system quantity dropped to zero after gear extended. Right body gear down lock actuator cracked.
37	6-6-75	#1	#1 hydraulic system fluid lost in flight at gear extension. Left body gear down lock actuator leaking.

<u>Registration Number</u>	<u>Date</u>	<u>System Lost</u>	<u>Description</u>
50	6-26-75	#2	#2 EDP failed in flight, hydraulic quantity dropped to zero with ADP on. EDP failure and leakage.
54	7-1-75	#4	#4 EDP L.P. light on after takeoff and ADP run light on, hydraulic quantity dropped to zero. ADP pressure line seal leaking, EDP shaft sheared.
39	7-7-75	#1	#1 hydraulic system quantity dropped to zero. Nose landing gear up line chafed through by duct clamp.
38	7-25-75	#1	#1 hydraulic system fluid lost, used alternate mode to extend landing gear. EDP overboard drain and pressure hose leaking.
70	8-30-75	#3	#3 hydraulic system leaking, ADP off and EDP depressurized. Upper rudder power package filter housing plug broken.
43	9-7-75	#1	#1 engine lost in flight, #1 hydraulic system quantity dropped, EDP and ADP turned off. EDP leaking at base.
48	10-21-75	#1	#1 hydraulic system quantity lost on landing gear extension.
32	10-22-75	#1	#1 hydraulic system quantity lost during approach. Right body gear downlock actuator leaking.
41	11-21-75	#1	#1 hydraulic system quantity lost. EDP cracked.
57	12-12-75	#1	#1 hydraulic system quantity lost. EDP shaft sheared and leaking.
33	1-1-76	#1	#1 hydraulic system fluid quantity dropped to zero on final with gear and flaps extended. Body gear downlock actuator leaking.
32	1-25-76	#1	#1 hydraulic system quantity slowly dropped, ADP off and EDP depressurized, used alternate mode for gear and flap extension leak in hydraulic line to stabilizer. Retorqued fitting.
59	2-20-76	#4	#4 hydraulic system fluid quantity lost. Replaced pressure line to ADP and heat exchanger case return.

<u>Registration Number</u>	<u>Date</u>	<u>System Lost</u>	<u>Description</u>
50	3-19-76	#2	#2 hydraulic system fluid quantity lost during flight. Rudder power package filter cap sheared off.
71	4-7-76	#1	#1 hydraulic system fluid lost. No leaks found.
56	4-21-76	#1	#1 hydraulic system fluid lost. Supply line to shut off valve leaking.

AIRLINE B-747 HYDRAULIC SYSTEM LOSS SUMMARY
February 1975 - April 1976

74,788 FLIGHT HOURS

<u>Registration Number</u>	<u>Date</u>	<u>System Lost</u>	<u>Description</u>
15	2-4-75	#4	Lost #4 hydraulic system fluid. EDP replaced.
07	2-10-75	#2	Lost #2 hydraulic system fluid. Line failure downstream of #2 case drain filter.
02	4-8-75	#1	#1 hydraulic system leak enroute, shutoff ADP and depressurized EDP. Central lateral hydraulic control unit had a pinhole leak.
11	6-2-75	#3	Lost #3 hydraulic system fluid. Upper rudder power package filter housing ruptured.
15	6-13-75	#3	Hydraulic system #3 failed. Filter cap on elevator feel computer failed.
11	6-30-75	#4	#4 hydraulic system quantity dropped to zero on flap or gear extension. Four way hydraulic fitting in right wheel well leaking.
18	9-15-75	#3	#3 hydraulic system fluid lost in cruise. Hydraulic line in ADP compartment failed.
02	11-11-75	#2	#2 hydraulic system fluid leaking, ADP off and EDP depressurized. Lower rudder power package filter cap broken.
02	2-10-76	#4	#4 tire blew recap on rotation, lost hydraulic system #4 quantity. Hydraulic line fitting broken.
15	3-5-76	#1	Lost all fluid from #1 hydraulic system. Pump and filters replaced.
10	4-5-76	#2	Returned after takeoff. Lost #2 hydraulic system quantity. Pump pressure hose ruptured.
13	4-6-76	#3	Lost #3 hydraulic system, found no leaks.

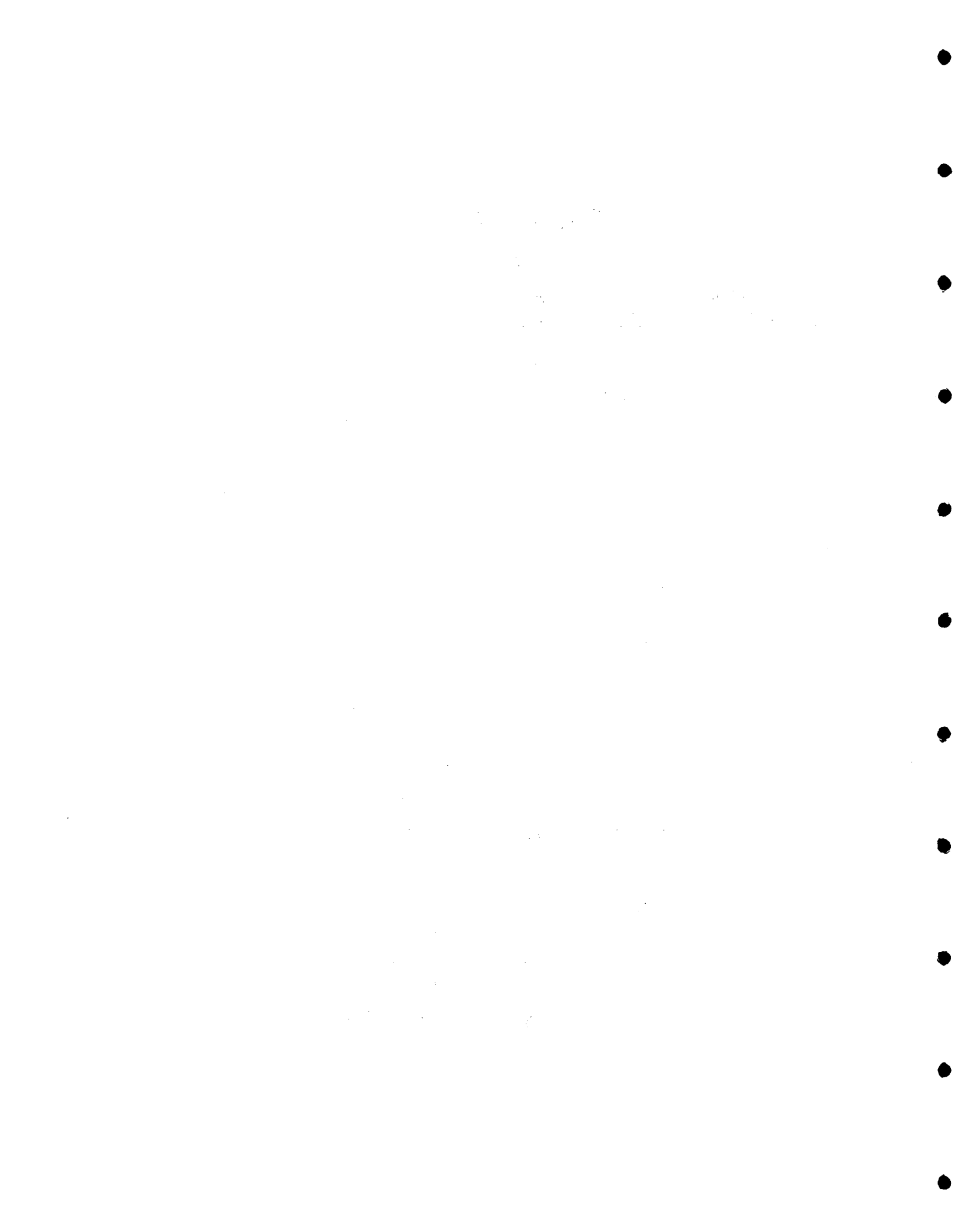

APPENDIX E

SCHEDULED MAINTENANCE REQUIREMENTS

The following pages were extracted from the Boeing 747 maintenance planning document which includes inspection tasks at recommended frequencies for airplane components and systems.

Scheduled maintenance costs can be assessed from the stated manhours for accomplishing each task.

MODEL: ALL	TASK			REFERENCE		LOCATION		TIME		
	DESCRIPTION	CHECK	LUBRICATE	OTHER	INSP. CARD	MAINT. MANUAL	ZONE	ACCESS DOOR NUMBER	HRS & TENTHS	
ELAPSED									MAN HRS	
FLIGHT CONTROLS										
4-27-01	Ailerons, inbd. and outbd., including:	X		*		27-11-00	579	573AB	1.9	3.8
	A. exterior surfaces (including delamination)						592	573BB		
	B. aileron actuators						679	573CB		
	C. exposed linkages						692	591AB		
	D. hinge bearings and mechanisms						591	thru		
	E. exposed areas of balance weights and seals						135	591FB		
	F. wire bond installations							same		
	G. outboard aileron lockout drive screws		X	2C		12-21-16		right wing		
4-27-02	Inboard and outboard aileron control mechanism installations, including:	X		*		27-11-00	579	573AB	3.2	6.5
	A. aileron power units, quadrants, linkage and outboard aileron lockout mechanisms						592	573BB		
	B. aileron trim and feel units, trim motors, centering and control mechanisms						679	573CB		
	C. accessible cables, pulleys, brackets, fairleads and quadrants in wings and wheel wells		X	2C		12-21-05	692	591AB		(3.8)
	D. aileron programmers		X	2C		12-21-16	135	thru		(.4)
	E. aft lost motion device						136	591FB		
	F. aileron input and output bus rod and load limiter						211	same		
	G. central control units						212	right wing		
							245	CP		
							246			

REVISED: J

DATE 4-7-70 NO. D6-13747
SECTION 4-27 PAGE 1



E-2

MODEL: ALL		TASK		REFERENCE		LOCATION		TIME	
DESCRIPTION	CHECK	LUBRICATE	OTHER	INSP. CARD	MAINT. MANUAL	ZONE	ACCESS DOOR NUMBER	HRS & TENTHS	
								ELAPSED	MAN HRS
FLIGHT CONTROLS									
4-27-02 (cont'd.)	X								
H. aileron back drive and force limiter									
I. position transmitter			*						
J. load limiter shaft assembly and aileron bus drum and cables under cockpit floor in area of control columns and control stand aft to BS 460	X		* 4C		12-21-05				(.5)
K. inboard and outboard PCU's and central lateral control package			*F/C (4000 Hrs)		29-11-00				
L. inboard and outboard aileron system using hydraulic systems 1, 2, 3 & 4 independently.			OP/C		27-11-00				(.3)
4-27-03 Inboard and outboard spoilers, including (with spoilers raised):	X		*		27-61-00	582 585 682 685 584 583 574 575	N/A	1.3	2.6
A. exposed surfaces									
B. hinge bearings									
C. actuators, fittings and lines									
D. wire bond installations									
E.. wing spoiler cables, brackets, fairleads		X			12-21-05				

E-3



BOEING 707
MAINTENANCE REQUIREMENTS

"C" CHECK TYPE ITEMS

MODEL: ALL	TASK			REFERENCE		LOCATION		TIME		
	DESCRIPTION	CHECK	LUBRICATE	OTHER	INSP. CARD	MAINT. MANUAL	ZONE	ACCESS DOOR NUMBER	HRS & TENTHS	
									ELAPSED	MAN HRS
FLIGHT CONTROLS										
4-27-04	Spoilers and speed brake control mechanisms, including:	X		*		27-61-00 27-62-00	131 132 500 600 135 136	N/A	2.0	3.9
	A. spoiler speed brake mixer assemblies and differential mechanism									
	B. control linkage and valves									
	C. actuators and valves									
	D. speed brake sequence mechanism									
	E. accessible cables, pulleys, quadrants, brackets and fairleads in the wheel wells		X			12-21-05				
	F. speed brake cables under pilot's control stand and cockpit floor aft to BS 460		X	*4C		12-21-05				(1.0)
	G. inbd. & outbd. flight spoilers - power control packages			*F/C (4000 Hrs)		29-11-00				
	H. ground spoiler control valve assembly			*F/C (4000 Hrs)		27-62-04				(2.0)
	I. Position transmitters									

E-4

REVISED: J

DATE 4-7-70 | NO. D6-13747
 SECTION 4-27 | PAGE 3



BOEING 767

MAINTENANCE REQUIREMENTS

"C" CHECK TYPE ITEMS

MODEL: ALL	TASK			REFERENCE		LOCATION		TIME	
DESCRIPTION	CHECK	LUBRICATE	OTHER	INSP. CARD	MAINT. MANUAL	ZONE	ACCESS DOOR NUMBER	HRS & TENTHS	
								ELAPSED	MAN HRS
FLIGHT CONTROLS									
4-27-05 Wing flap installation, trailing edge, left and right, including: A. fore, mid and aft flap exterior surfaces and fairings B. flap tracks, rollers and carriages C. flap rub strips and seals D. inbd & outbd carriage fittings NOT APPLICABLE ON SP	X		*		27-51-00	5/676 5/677 5/678 5/686 5/687 5/688 5/670 5/680	N/A	2.0	8.0
4-27-05 Wing flap installation, trailing edge, left and right, including: A. inboard and outboard flap exterior surfaces and fairings B. flap crank arms, aft links and fittings C. flap rub strips and seals D. inbd, center & outbd carrier beam fittings APPLICABLE TO SP ONLY	X		*		27-52-00	5/677 5/686 5/687 5/670 5/680	N/A	2.0	8.0

E-5



BOEING 747
MAINTENANCE REQUIREMENTS

"C" CHECK TYPE ITEMS

MODEL: ALL		TASK			REFERENCE		LOCATION		TIME	
DESCRIPTION	CHECK	LUBRICATE	OTHER	INSP. CARD	MAINT. MANUAL	ZONE	ACCESS DOOR NUMBER	HRS & TENTHS		
								ELAPSED	MAN HRS	
FLIGHT CONTROLS										
4-27-06	X		*		27-81-00	500 600		9.1	36.4	
A. exterior surfaces B. linkages C. pneumatic drive units D. ballnut and screw assemblies (Krueger)										
		X	2C		12-21-23				(.9)	
E. rotary actuators F. torque tubes and "U" joints G. transmission assemblies (Krueger)										
		X	5C		12-21-23				(13.1)	
H. position transmitters I. drive unit splice couplings										
		X	5C		12-21-23				(13.1)	
4-27-07	X		*		27-51-00	137 138 500 600	N/A	5.0	22.3	
A. flap drive torque tubes and bearing supports B. flap drive gear boxes and transmissions or offset transmissions as applicable C. flap actuating hydraulic motors and power units D. electrical flap drive units E. flap control modules										
		X	2C		12-21-21	211			14.0)	
		X	5C		12-21-25	212			(1.0)	
					12-21-20	232				
					12-21-23	252				
					27-51-16	570				
			*F/C		27-52-16	580			(1.0)	
			(4000 Hrs)		29-11-00	670				
			*F/C		27-51-17	680			(.5)	
			(4000 Hrs)		27-52-17					
			*F/C		27-51-10					
			(4000 Hrs)		27-52-10					
					29-11-00					

E-6

REVISED: J

DATE 4-7-70 | NO. D6-13747
 SECTION 4-27 | PAGE 5



BOEING 787

MAINTENANCE REQUIREMENTS

"C" CHECK TYPE ITEMS

MODEL: ALL	TASK			REFERENCE		LOCATION		TIME	
DESCRIPTION	CHECK	LUBRICATE	OTHER	INSP. CARD	MAINT. MANUAL	ZONE	ACCESS DOOR NUMBER	HRS & TENTHS	
								ELAPSED	MAN HRS
FLIGHT CONTROLS									
4-27-07 (Cont'd)	X	X			12-21-05				
F. accessible cables, pulleys, brackets and fairleads in body gear wheel wells	X	X							
G. ball bearing screw assemblies (N/A ON SP)									
H. position transmitters									
I. linear flap load relief actuators (OPTIONAL ON SP)			*F/C (4000 Hrs)		27-51-32			(.2)	(.2)
J. accessible flap carriages (N/A ON SP)									
K. flap control cables under pilot's control stand and cockpit floor aft to BS 460			*4C		12-21-05			(.5)	(.5)
L. rotary actuators (SP ONLY)									
M. Cruise flap failure protection system			OP/C 2C		27-51-00 27-52-00			(.3)	(.6)
4-27-08 Elevators, including:	X		*		27-31-00	330	335GB	1.5	2.6
A. inbd and outbd elevator attachment hinges						340	344GB 334KB 344KB		
B. exterior surfaces									
C. thrust hinge attachments									
D. wire bond installations									
E. mass balance weight installation (outboard)									
4-27-09 Elevator control mechanisms, including:	X		*		27-31-00	211	315AL	7.8	7.8
A. aft quadrant, feel unit and actuators						311	334HB		
B. crank assembly						312	334LB		
						330	344HB		
						340	344LB		
						315			
						316			



E-7

BOEING *747*
MAINTENANCE REQUIREMENTS

"C" CHECK TYPE ITEMS

MODEL: ALL	TASK			REFERENCE		LOCATION		TIME	
	CHECK	LUBRICATE	OTHER	INSP. CARD	MAINT. MANUAL	ZONE	ACCESS DOOR NUMBER	HRS & TENTHS	
								ELAPSED	MAN HRS
FLIGHT CONTROLS									
4-27-09 (Cont'd.)									
	X		4C			333 334		(.8)	(1.5)
	X								
	X								
		X	2C		12-21-05				
		X	* 4C		12-21-05			(.5)	(.5)
			*F/C (4000 HRS)		29-11-00			(.4)	(.8)
			*F/C (4000 HRS)		27-31-14			(2.0)	(4.0)
			OP/C		27-31-00			(.2)	(.2)

REVISED J

DATE 4-7-70 NO. D6-13747
 SECTION 4-27 PAGE 7



E-8

BOEING 747
MAINTENANCE REQUIREMENTS

"C" CHECK TYPE ITEMS

MODEL : ALL		TASK			REFERENCE		LOCATION		TIME	
DESCRIPTION	CHECK	LUBRICATE	OTHER	INSP. CARD	MAINT. MANUAL	ZONE	ACCESS DOOR NUMBER	HRS & TENTHS		
								ELAPSED	MAN HRS	
FLIGHT CONTROLS										
4-27-10 Upper and lower rudders, including: A. rudder hinges and thrust hinges B. exterior surfaces C. wire bond installation NOT APPLICABLE ON SP.	X		*		27-21-00	325 326	324BL thru 324ML	1.3	1.3	
4-27-10 Upper and lower rudders and tabs including: A. rudder and tab hinges and thrust hinges B. exterior surfaces C. wire bond installation D. rudder tab control rod APPLICABLE TO SP ONLY	X		*		27-22-00	325 326	324BL thru 324ML	1.3	1.3	
4-27-11 Rudder control mechanism installation including: A. rudder feel and centering spring trim assembly and trim actuator B. rudder control linkage assembly, aft C. rudder power control units D. rudder ratio changer mechanism and linear actuators E. position transmitter F. cables in fuselage tail compartment G. rollout guidance override mechanism springs	X		*		27-21-00 27-22-00	320 210	312AR 324DL 324HL 313AL CP	4.0	4.0	

E-9



BOEING 747
MAINTENANCE REQUIREMENTS

"C" CHECK TYPE ITEMS

MODEL : ALL	TASK			REFERENCE		LOCATION		TIME		
	DESCRIPTION	CHECK	LUBRICATE	OTHER	INSP. CARD	MAINT. MANUAL	ZONE	ACCESS DOOR NUMBER	HRS & TENTHS	
									ELAPSED	MAN HRS
FLIGHT CONTROLS										
4-27-11 (NOTE: This check required on (Cont'd) airplanes equipped with automatic rollout guidance function of fail-operative autopilot system, only. (See items 4-22-03, 4-24-06 and 4-34-18, also).										
H. rudder control linkage assembly, forward			*4C						(.3)	(.3)
I. forward rudder quadrant assembly and tension regulator			*4C						(.3)	(.3)
J. rudder control and trim cables under cockpit floor in area of control stand and forward cable quadrant and aft to BS 460		X	*4C		12-21-05				(.3)	(.3)
K. upper and lower rudder power control units			*F/C (4000 Hrs)		29-11-00				(.5)	(1.0)
L. upper and lower rudder control systems using hydraulic systems 1, 2, 3 and 4 independently			OP/C		27-21-00 27-22-00				(.5)	(1.0)
4-27-12 Rudder pedals and jackshaft assemblies	X		*4C		27-21-00 27-22-00	221 222	N/A		.2	.4
4-27-13 Stabilizer trim control and trim indicating cables under cockpit floor in area of pilot's control stand and aft to BS 460	X	X	*4C		27-41-00 12-21-05	210	B12AR CP		2.5	.5
4-27-14 Stabilizer actuating mechanism, including:	X		*		27-41-00	311 312 211 233	B12AR		7.8	7.8
A. control modules										

E-10

REVISED: J

DATE 4-7-70 | NO. D6-13747
 SECTION 4-27 | PAGE 9



BOEING 747
MAINTENANCE REQUIREMENTS

"C" CHECK TYPE ITEMS

MODEL : ALL	TASK			REFERENCE		LOCATION		TIME	
	CHECK	LUBRICATE	OTHER	INSP. CARD	MAINT. MANUAL	ZONE	ACCESS DOOR NUMBER	HRS & TENTHS	
								ELAPSED	MAN HRS
FLIGHT CONTROLS									
4-27-14 (Contd.)									
B. arming and control system input rods and cables, pulleys, brackets and fair-leads		X	2C		12-21-05	234 243 244 300			
C. upper and lower gimbal assemblies									
D. stabilizer trim drive motors, brakes and mechanisms									
E. stabilizer jackscrew ballnut									
F. accessible hinge fittings									
G. cables in fuselage tail compartments		X	2C						(.3)
H. stabilizer trim hyd. supply shutoff			*OP/C (4000 Hrs)		27-43-00			(1.0)	(2.0)
I. drive limit switch (switch setting)		X	*F/C (4000 Hrs)		27-41-08			(1.0)	(2.0)
J. modular package assembly - stabilizer control (internal leakage)			*F/C (4000 Hrs)		29-11-00			(1.0)	(2.0)
K. stabilizer trim system using hydraulic systems 1, 2 and 3 independently			OP/C		27-41-00			(.2)	(.2)
L. stabilizer trim indicating system			OP/C 2C		27-48-00			(.5)	(.5)
4-27-15 Trailing edge flaps		X			27-51-00	500	N/A	2.5	5.0
A. modular assembly, flap control, inboard (internal leakage check)			*F/C (4000 Hrs)		29-11-00	600			(.5)
					27-52-00	130			
						137			
B. modular assembly, flap control, outboard (internal leakage check)			*F/C (4000 Hrs)		29-11-00	138			(.5)



E-11

BOEING 747
MAINTENANCE REQUIREMENTS

" C " CHECK TYPE ITEMS

MODEL : ALL	TASK			REFERENCE		LOCATION		TIME	
	CHECK	LUBRICATE	OTHER	INSP. CARD	MAINT. MANUAL	ZONE	ACCESS DOOR NUMBER	HRS & TENTHS	
								ELAPSED	MAN HRS
FLIGHT CONTROLS									
4-27-15			(Cont'd)						
			C. power package assembly, flap drives, inboard and outboard		*F/C (4000 Hrs)	29-11-00			(.5)
			D. alternate drive motor, T.E. flap (check system)		*F/C (4000 Hrs)	27-51-17 27-52-17			(.5)
4-27-16	X		Transmitter, flap position and stall warning (asymmetry, stall warning system calibration) (DELETE STALL WARNING ON SP)		*F/C	27-32-00 27-58-00	221 500 600	N/A	2.0 4.0
4-27-17	X		Over-rotation warning system		*F/C (4000 Hrs)	27-35-00	118 220 700	N/A	.5 .5
4-27-18	X		Trailing edge drive transmission and ball bearing screw assembly, inboard and outboard (8 units) NOT APPLICABLE ON SP		*	27-51-00 27-51-33 27-51-41	570/80 670/80	N/A	6.0 48.0
4-27-19	X		Forward rudder quadrant assembly and tension regulator		*	27-21-00 27-21-06	211	211G	1.0 2.0
4-27-20	X		Forward elevator control and tension regulator quadrant		*	27-31-00 27-31-05	211	211C	1.0 2.0
4-27-21	X	X	Cable inspection, including vertical fin and horizontal stabilizer - protected area.		*	20-11-03 12-21-05	300	N/A	1.5 3.0

E-12

REVISED: J

DATE 9-14-73 | NO. D6-13747

SECTION 4-27 | PAGE 11



APPENDIX F

DELAY/CANCELLATION COST ALGORITHM

Costs associated with flight delays and cancellations are difficult to measure. The following algorithms, based on airline industry cost estimates, used such factors as number of passenger seats and average flight length.

Delays

For design study purposes delay costs can be considered as consisting of:

Passenger handling costs

Extra crew costs

Lost passenger revenue

No satisfactory method has been developed to include any loss of goodwill which results from a delay. Delay cost may be calculated from the formula:

$$DC = (PHC + ECC + LPR) \\ \times SQA \times DPC \times ADM \times UTIL \times NA \times ERC / (AFLH \times 6000)$$

where:

- DC = Delay cost dollars/year/fleet
- PHC = Passenger handling cost, \$'s/seat delay hour
- PHC(76) = 0.2171
- ECC = Extra crew cost, \$'s per seat delay hour
- ECC(76) = 2.442 - 0.0038 SQA
- LPR = Lost passenger revenue
(\$ per seat delay hour)
- LPR(76) = (LFR x (27.5689 AFLH - 1.373) \\ \times .8712 EXP(.0454 - .2271 AFLH)) / \\ (1 + 1.3877 AFLH)
- SQA = Seat quantity
- LFR = Load factor (decimal, not %)

SQA = Seat quantity, actual
 DPC = Delays per 100 flights
 ADM = Average delay time per delay (minutes)
 UTIL = Utilization in hours per year per airplane
 NA = Number of airplanes in the fleet
 AFLH = Average flight length (hours)
 LRC = Delay rate correction factor

 DRC = $\frac{DAFL}{AFLH} \left(1 - \frac{F \times DAFL}{(F \times DAFL) + 1 - F} \right) + \frac{F \times DAFL}{(F \times DAFL) + 1 - F}$

 DAFL = Average flight length (hours) associated
 with DPC

 F = Flight hour/flight cycle factor for one
 hour flight from Figure 1

<u>System</u>	<u>F</u>	<u>System</u>	<u>F</u>
21 Air Conditioning	.58	49 APU	.90
22 Automatic Flight	.59	52 Door	.51
23 Communications	.66	53 Fuselage	.50
24 Electrical	.74	54 Nacelle/Pylon	.90
25 Equipment and Furnishings	.38	55 Stabilizers	.49
26 Fire Protection	.25	56 Window	.90
27 Flight Control	.92	57 Wing	.49
28 Fuel	.94	71 Power Plant	.98
29 Hydraulics	.98	72 Engine	.89
30 Ice and Rain Rem.	.97	73 Engine Fuel	1.00
31 Instruments	.65	74 Ignition	1.00
32 Landing Gear	.18	75 Engine Air	.29
33 Lighting	.78	76 Engine Control	1.00
34 Navigation	.67	77 Engine Indicators	.85
35 Oxygen	.55	78 Exhaust	.45
36 Pneumatics	.26	79 Engine Oil	.57
38 Water and Waste	.33	80 Starting	.67
		82 Water Injection	.45
		99 Overall Airplane	.78

Flight Length Correction Formula:

$$C = \frac{C_b L_b}{(L_b - 1) F + 1} \times \left(F + \frac{1-F}{L} \right)$$

Where: C_b = Cost per flight hour at baseline flight length

L_b = Baseline flight length in hours

F = Flight hour fraction of flight hour - flight cycle distribution for a one hour flight
(from table above)

L = Flight length of new design in hours

C = Cost per flight hour of new design

FIGURE 1. FLIGHT LENGTH CORRECTION FACTOR

Cancellations

Cancellation costs consist of all the costs of a delay up to the time at which a flight is cancelled plus costs associated with loss of use of the airplane for the flight hours it is out of service. Calculation of the delay cost portion of cancellations is based on the average delay time preceding a cancellation, ADMC.

$$CN = (CNDC + CNDL) \times CNPM \times UTIL \times NA / (1000 \times AFLH)$$

where:

$$CN = \text{Cancellation dollars/year/fleet}$$

$$CNDC = \text{Cancellation delay, \$'s/cancellation}$$

$$CNDL = \text{Cancellation downtime, \$'s/cancellation}$$

$$CNPM = \text{Cancellations/1000 departures/airplane}$$

$$UTIL = \text{Utilization flight hours/year/airplane}$$

$$NA = \text{Number of airplanes in the fleet}$$

$$AFLH = \text{Average flight length in hours}$$

Cancellation, Delay Cost Contribution

$$CNDC = (PHC + ECC + LPR) \times SQA \times ADMC \times DRC/60$$

where:

$$ADMC = \text{Average delay minutes preceding cancellation}$$

$$= 25 + 35.2 \times AFLH$$

$$AFLH = \text{Average flight length in hours}$$

Cancellation Downtime Loss Contribution

$$\text{CNDL}(72) = 0.003 \times \text{OEW} \times \text{FHL}$$

where:

OEW = Operating empty weight, pounds

FHL = Flight hours lost, hours

It should be noted that the above does not include the costs of eliminating problems which cause the cancellation.

1. Report No. CR-159010	2. Government Accession No.	3. Recipient's Catalog No.	
4. Title and Subtitle B-747 Primary Flight Control Systems Reliability and Maintenance Study		5. Report Date APRIL 1979	6. Performing Organization Code
		8. Performing Organization Report No. D6-46350	
7. Author(s) BCAC Product Assurance Unit		10. Work Unit No.	
9. Performing Organization Name and Address Boeing Commercial Airplane Company (BCAC) P.O. Box 3707 Seattle, Washington 98124		11. Contract or Grant No. NAS1-14742	
		13. Type of Report and Period Covered Contractor Report - Final AUG 1977 - JULY 1978	
12. Sponsoring Agency Name and Address National Aeronautics and Space Administration Washington, D.C. 20546		14. Sponsoring Agency Code	
15. Supplementary Notes This report covers work conducted under one of five tasks included in Contract NAS1-14742.			
16. Abstract The major operational characteristics of the 747 Primary Flight Control Systems (PFCS) are described. Results of reliability analysis for separate control functions are presented. The analysis makes use of a NASA computer program which calculates reliability of redundant systems. Costs for maintaining the 747 PFCS in airline service are assessed. The reliabilities and costs will provide a baseline for use in trade studies of future flight control system design.			
17. Key Words (Suggested by Author(s)) Reliability Maintenance Cost 747 PFCS		18. Distribution Statement FEDD Distribution	
19. Security Classif. (of this report) Unclassified	20. Security Classif. (of this page) unclassified	21. No. of Pages	22. Price*

AVAILABLE: NASA'S Industrial applications centers

