

NASA CR-164550



NASA-CR-164550  
1981 00 18653

# LIQUID ROCKET PROPULSION TECHNOLOGY

## An Evaluation of NASA's Program

Aeronautics and Space Engineering Board  
Assembly of Engineering  
National Research Council



LIBRARY COPY

NOV 30 1981

LANGLEY RESEARCH CENTER  
LIBRARY, NASA  
HAMPTON, VIRGINIA

# LIQUID ROCKET PROPULSION TECHNOLOGY

## An Evaluation of NASA's Program

Report of the ad hoc Committee on  
Liquid Rocket Propulsion Technology

Aeronautics and Space Engineering Board  
Assembly of Engineering  
National Research Council

NATIONAL ACADEMY PRESS  
Washington, D.C. 1981

N81-27191#

NOTICE: The project that is the subject of this report was approved by the Governing Board of the National Research Council, whose members are drawn from the Councils of the National Academy of Sciences, the National Academy of Engineering, and the Institute of Medicine. The members of the committee responsible for the report were chosen for their special competences and with regard for appropriate balance.

This report has been reviewed by a group other than the authors according to procedures approved by a Report Review Committee consisting of members of the National Academy of Sciences, the National Academy of Engineering, and the Institute of Medicine.

The National Research Council was established by the National Academy of Sciences in 1916 to associate the broad community of science and technology with the Academy's purposes of furthering knowledge and of advising the federal government. The Council operates in accordance with general policies determined by the Academy under the authority of its congressional charter of 1863, which establishes the Academy as a private, nonprofit, self-governing membership corporation. The Council has become the principal operating agency of both the National Academy of Sciences and the National Academy of Engineering in the conduct of their services to the government, the public, and the scientific and engineering communities. It is administered jointly by both Academies and the Institute of Medicine. The National Academy of Engineering and the Institute of Medicine were established in 1964 and 1970, respectively, under the charter of the National Academy of Sciences.

This report and the study on which it is based were supported by Contract No. NASW-2342 between the National Aeronautics and Space Administration and the National Academy of Sciences.

Copies of this publication are available from:

Aeronautics and Space Engineering Board  
National Research Council  
2101 Constitution Avenue, N.W.  
Washington, D.C. 20418

AD HOC COMMITTEE ON LIQUID ROCKET PROPULSION

B. Paul Blasingame, Chairman  
Consultant (Former Manager,  
Santa Barbara Operations  
Delco Electronics Div.,  
General Motors Corporation)

Gerald W. Elverum, Jr.  
Manager, Power Systems Operations  
TRW Defense & Space Systems Group  
TRW Inc.

Robert R. Gilruth  
Consultant (Former director of  
NASA's Johnson Space Center)

Grant L. Hansen  
President, SDC Systems  
Systems Development Corporation

Richard Hartunian  
Vice President & General Manager,  
Space Launch Vehicle Division  
Aerospace Corporation

CONSULTANTS

Richard C. Mulready  
Director, Technical Planning  
Pratt & Whitney Aircraft

Roger I. Ramseier  
President  
Aerojet Liquid Rocket Company

Norman C. Reuel  
Executive Vice President & Director  
International Programs  
Rocketdyne Division  
Rockwell International Corp.

Gershom R. Makepeace  
Director of Engineering Technology,  
Office of the Undersecretary for  
Defense Research & Engineering  
Department of Defense

Simon Ostrach  
Professor, Department of Mechanical  
and Aerospace Engineering  
Case Western Reserve University

Abe Silverstein  
Consultant (Former director of  
NASA's Johnson Space Center)

William F. Villines  
Assistant Deputy Expendable  
Launch Vehicles  
Office of Deputy for Space Launch  
Systems  
Space Division  
United States Air Force

STAFF

Albert J. Evans  
Project Officer

Laura D'Sa  
Administrative Secretary

-----  
S. Edward Gamarekian  
Editor Consultant

AERONAUTICS AND SPACE ENGINEERING BOARD

Robert W. Rummel, Chairman  
President  
Robert W. Rummel Associates, Inc.

Robert A. Fuhman, Vice Chairman  
President  
Lockheed Missiles and Space Co., Inc.

Neil A. Armstrong  
Chairman of the Board  
Cardwell International, Ltd.

Holt Ashley  
Professor of Aeronautics/  
Astronautics & Mechanical Engineering  
Stanford University

Richard E. Black  
Director, Technologies  
Douglas Aircraft Company

B. Paul Blasingame  
Former Manager  
Santa Barbara Operations  
Delco Electronics Division  
General Motors Corporation

John G. Borger  
Former Vice President,  
Engineering  
Pan American World Airways

Edward S. Carter  
Director of Technology  
Sikorsky Aircraft Division  
United Technologies Corporation

Richard J. Coar  
Executive Vice President  
Power Group  
United Technologies Corporation

Robert R. Gilruth  
Former Director  
Lyndon B. Johnson Space Center  
National Aeronautics and Space  
Administration

Grant L. Hansen  
President, The Systems Group  
System Development Corporation

Ira Grant Hedrick  
Senior Vice President and  
Presidential Assistant for  
Corporate Technology  
Gruman Aerospace Corporation

Klaus P. Heiss  
President  
ECON, Inc.

Jack L. Kerrebrock  
R.C. MacLaurin Professor and  
Head, Department of Aeronautics  
and Astronautics  
Massachusetts Institute of  
Technology

Hans W. Liepmann  
Director, Graduate Aeronautical  
Laboratories  
California Institute of Technology

James W. Mar  
Jerome C. Hunsaker Professor of  
Aerospace Education  
Massachusetts Institute of  
Technology

Robert B. Ormsby, Jr.  
President  
Lockheed-Georgia Company

George S. Schairer  
Consultant  
The Boeing Company

A. Richard Seebass  
Professor of Aerospace Engineering  
and Mathematics  
University of Arizona

Gordon Sim  
Vice President  
Program Management  
Rohr Industries, Incorporated

John E. Steiner  
Vice President, Corporate  
Product Development  
The Boeing Company

Robin H.H. Wilson  
Senior Vice President  
Operations  
Trans World Airlines Incorporated

Edward Woll  
Former Vice President  
Project and Technology  
Assessment Group  
General Electric Company

Executive Staff

Robert J. Burger, Executive Director

John Peter Taylor, Assistant Director

Albert J. Evans, Professional Associate

**This Page Intentionally Left Blank**

## P R E F A C E

At a regularly scheduled meeting of the Aeronautics and Space Engineering Board (ASEB) of the National Research Council in April 1979, a proposed 10-year program of research and technology development in liquid rocket propulsion that had been prepared by the Office of Aeronautics and Space Technology, National Aeronautics and Space Administration (NASA) was described. The plan for such a program resulted from concern about the prospective availability of the technology and the industrial capability to develop and produce the advanced liquid rocket propulsion systems that are seen as being required for future space missions. The ASEB was asked by NASA to comment on the proposed program. NASA was concerned about the focus of its proposed program and whether it is important or necessary to support an acceptable liquid rocket capability in industry for future space mission needs.

At its meeting the ASEB observed that before any conclusions could be drawn more information and study would be needed regarding NASA's present program and its future plans. Therefore, to accomplish the requested review, the ASEB set up an ad hoc Committee on Liquid Rocket Propulsion and charged it with several tasks--specifically to:

- o Examine and assess the appropriateness, adequacy, and timing of NASA's planned research and technology development program for liquid rocket motors and vehicles that are foreseen as being required for the U.S. space program over the next few decades, and
- o Provide recommendations on the objectives, approach, and content of the plan.

The committee met at the National Academy of Sciences in Washington, D.C., on March 25-26, April 29-30, and May 14-15, 1980. Representatives from NASA, Rocketdyne, Aerojet, and Pratt & Whitney were called in when needed to provide information and answer questions, but were not present during discussions relating to the conclusions and recommendations in this report.

The committee did not examine or evaluate any of the programs for the development of the small non-cryogenic liquid engines used for guidance and orbital maneuvering because the development of such engines is well in hand and the industrial capability in this area is likely to be maintained in the foreseeable future.



**This Page Intentionally Left Blank**

## CONTENTS

	Page
SUMMARY CONCLUSIONS AND RECOMMENDATIONS	1
INTRODUCTION	5
MISSION MODEL	7
Missions Planned for Space Shuttle, 1981-1986	10
Probable Future Missions	10
EARTH-TO-ORBIT VEHICLES	15
Space Shuttle	15
Projected Vehicle Needs	17
Single-Stage-to-Orbit Vehicles	18
Heavy-Lift Launch Vehicles	20
Integrated Orbit Maneuvering and Reaction Control System	23
Technology Needs and Conclusions	23
ORBITAL TRANSFER VEHICLES	27
Dual-Thrust	28
Separate High-Thrust and Low-Thrust	28
Comparison of concepts	28
PLANETARY SPACECRAFT RETRO-PROPULSION SYSTEMS	35
Pressure-Fed Systems	35
Pump-Fed Systems	36
Assessment of Planetary Retro-Propulsion Program	36
FUNDAMENTAL TECHNOLOGY PROGRAM	37
Pumps and Pump Drives	37
Combustion	39
Heat Transfer	40
Nozzle Aerodynamics	41
Low-Gravity Cryogenic Fluid Management	42
Component and System Life, Reliability, and Maintenance	44
Assessment of NASA's Fundamental Technology Program	46

	Page
LIQUID ROCKET PROPULSION FOR DOD PROGRAMS	47
Military Mission Model	47
Launch Vehicles for Military Space Missions	48
INDUSTRY CAPABILITY	49
BIBLIOGRAPHY	53

## SUMMARY CONCLUSIONS AND RECOMMENDATIONS

The committee has reviewed NASA's proposed 10-year program of research and technology development for liquid rocket propulsion systems and concludes that the emphasis of the proposed program should be shifted to the continued growth of the space shuttle. Technology development for new major space systems should be deferred.

In the committee's judgment the space shuttle and advanced versions of it will provide the principal space transport for the United States for the next 20 to 30 years, and the continued development of the shuttle main engine system to achieve design performance and life is the highest priority task in NASA's rocket engine program.

Continued growth of the shuttle capability may entail further thrust increases in the main engine. Emphasis should be placed on establishing the technology for upgrading the main engine to its maximum possible thrust level, together with assuring its long reusable life.

To gain the full use of the shuttle, a versatile upper stage will be needed for the rapid transfer of heavy payloads (10,000 to 12,000 pounds) into synchronous orbit. Low acceleration transfer of large flexible systems from assembly in low earth orbit to their operational altitudes must be included. Such requirements are best met with a LOX-hydrogen liquid-fueled engine with start-stop capability. The most economical and most practical engine for application in the needed thrust range of 1,000 to 20,000 pounds is a modified RL-10.

To provide for the longer term future needs, a liquid rocket propulsion technology program should be sustained in three general areas:

Orbital Transfer Vehicles--a probable future need is the low acceleration of large space structures from near earth orbit to geosynchronous orbit. For this application, a technology program leading to a low thrust long burn-time engine should be supported.

Earth-to-Orbit--whereas the liquid oxygen-hydrogen large thrust engines are receiving attention, there is utility in conducting studies of recoverable, reusable, long-life liquid oxygen-hydrocarbon engines.

Planetary Missions--present plans call for development of both pressure-fed and high pressure pump-fed fluorine engines for retro-propulsion. The committee has strong reservation regarding the use of liquid fluorine and recommends that the fluorine pump-fed engine not be pursued. The committee recommends a study of alternate pump-fed propellants.

It is essential to sustain a continuing program of fundamental research directed to current and advanced liquid propulsion rocket systems of the future. Such a program should constitute a significant portion of the research and technology development effort and include work on rocket combustion, heat transfer, materials, propellants, lubricants, and seals. Conceptual approaches to problems that can lead to new and innovative solutions should be made whenever possible. Research efforts directed to new major space systems--e.g. a space satellite power system, and the single-stage-to-orbit vehicle--should be limited to studies of economic and technical feasibility.

The committee has reviewed the military needs for liquid rocket propulsion over the next decade. In general, military needs for large rockets are most readily met with solid rockets. On the other hand, small thrust liquid rockets for control purposes are needed in military space craft and strategic military vehicles. Current technology and system developments provide for such needs, and there is an adequate industrial base for their supply.

Prompt implementation of the recommended program can productively sustain two contractors in the liquid booster rocket field, although their capabilities will not be directly competitive. Furthermore, the recommended program will not retain the engineering and production personnel and facilities needed to provide two competitive companies. The committee does not propose or recommend the artificial maintenance of a contractor in the absence of a real and supportible need for the output of such a contractor.

The importance the committee assigns to the success of the space shuttle program, its growth to the planned full operational capability, and the development of an orbital transfer vehicle cannot be overstated. This conviction is so strongly held that the committee's principal recommendations concern liquid rocket engine work that should be given high priority to assure the success of the space shuttle.

Specifically, the committee recommends:

- o Establishing a continuing program of improvement for the space shuttle main engine (SSME) beyond its initial operating capability.
- o Establishing the technology base of the SSME to provide the baseline for upgrading its maximum thrust level and reusable life.
- o A prequalification program for a modified RL-10 IIB engine (1,000-20,000 lbs thrust) as a versatile upper stage for both rapid and low-acceleration transfer of large flexible systems.

- o A longer range program directed to providing the technology for a low thrust engine (200-2,000 pounds) of long durability in order to acquire a capability for orbital transfer.
- o A strong program of fundamental research in areas such as combustion, heat transfer, materials, propellants, lubricants, and seals.
- o Trade-off studies between LOX/H<sub>2</sub> and LOX/hydrocarbon engines for earth-to-orbit missions.
- o Studies of propellants other than fluorine for pump-fed systems to further missions to planets in the solar system.
- o Review of the entire rocket propulsion field in about five years to update the conclusions of this committee. The next five years will presumably witness an important phase of maturation for the space shuttle and a better definition of geosynchronous payload requirements.

**This Page Intentionally Left Blank**

## I N T R O D U C T I O N

In the past two decades mankind has benefited from the use of space systems for communications, weather forecasting, terrestrial resource data acquisition, navigation, and scientific discoveries and understanding of the planet Earth and the solar system. In addition, space operations have become an important element of military defense. As the cost of placing payloads into orbit is brought down sharply, more space-based systems and networks may be expected. It is reasonable to conclude that just as the early launch vehicles stimulated today's uses of space systems, the shuttle and its upper stages will stimulate a great increase in the use of space.

Much of the outreach into space has resulted from the development of liquid rocket propulsion capability in the United States, which includes all phases of research, development, production, and field operations for fully supporting the high state of readiness in military ballistic missiles and space capabilities and the extraordinary civilian space activities. Some projections have indicated a need for advanced liquid rocket propulsion systems in the 1990's. For example, a technical committee of the American Institute for Aeronautics and Astronautics has stated that rapidly evolving space concepts and technologies will need advanced propulsion systems, citing an up-rated shuttle with recoverable, reusable, higher-energy liquid rocket boosters to replace the present solid rocket boosters, and a reusable orbital transfer stage to be used from the shuttle.\*

As a result of a recommendation of its Research and Technology Advisory Council in May 1978, NASA undertook a study to gain a better understanding of liquid rocket propulsion needs and possible technical advances.

In 1979 the House of Representatives Committee on Science and Technology expressed concern...

---

\* Space Transportation Systems 1980-2000, Aerospace Assessments Series, Volume I. American Institute of Aeronautics and Astronautics. New York, N.Y. 1978.



"with the declining industrial base for advanced chemical propulsion technology. In recent years the liquid rocket industry sales have become increasingly dominated by one engine development program because of limited new programs in the field. If our Nation is to be in a position to embark on future space initiatives, the government must make a deliberate determination as to the level and composition of the sustained industrial propulsion capability. To determine what national propulsion industry capability should be maintained, NASA should propose to the Congress a plan for advanced propulsion technology base activities and assess what portion of the industrial base will be maintained by their action."\*\*

As a consequence, NASA has prepared a program of research and technology development to advance the technologies that would enable the United States to effectively and economically embark on new space initiatives in the future. The program plan proposed by NASA spans a 10-year period at a total cost of approximately \$200 million.

The budget request for the U.S. National Aeronautics and Space Administration (NASA) for fiscal year 1981 is \$5.74 billion, of which 33 percent, or \$1.87 billion, is for the space shuttle. The FY 1981 NASA budget for Space Research and Technology is \$113 million, of which \$19 million is planned for the proposed research and technology development (R&T) for advanced liquid rocket propulsion systems discussed in this report. Funding for the proposed program would peak to \$32.6 million in FY 1984 and then taper off over the remainder of the decade.

It was the task of this committee to examine specifically the liquid rocket propulsion technology needs to support anticipated future space vehicles and discern what if any special action needs to be taken to assure that an industrial base is sustained.

\*\* U.S. Congress. House. Committee on Science and Technology, Report No. 96-52: Authorizing Appropriation to the National Aeronautics and Space Administration. Washington. U.S. Government Printing Office. March 19, 1979.

## MISSION MODEL

The planning of missions and the development of launching vehicles have historically been closely interrelated and will continue to be over the years ahead. Missions will be determined largely by the vehicles available to launch them and, where there are clearcut mission requirements that cannot be met with existing vehicles, new vehicle designs will be determined by the missions.

This chapter describes:

- o Missions that are planned with the various combinations of readily available liquid and solid rockets until the Space Shuttle becomes operational.
- o Missions that are planned using the Space Shuttle Space Transportation System for the period 1981-1986.
- o Probable future missions.

Until the Space Shuttle becomes operational, NASA and DOD will use available liquid and solid rockets to launch a variety of scientific, communication, meteorological, and other satellites into low earth and geosynchronous orbits.

NASA plans to use Scout, Delta, and Atlas-based vehicles (Figure 1) with lift-off thrusts of 95,000-1,000,000 lbs to place payloads of 200-4,000 lbs in low-earth and geosynchronous orbits. As of July 1980, the agency had 45 missions planned with such vehicles for the 1981-84 period, 38 from the east coast (Kennedy Space Center) and 7 from the west coast (Vandenberg Air Force Base).

DOD plans to use a series of Atlas-based and Titan-based vehicles (Figure 1) with lift-off thrusts of 430,000-2,400,000 lbs to launch payloads of 4,800-27,600 lbs in low-earth orbits and payloads of 2,400-4,000 lbs in geosynchronous orbits. As of July 1980, DOD had 45 missions planned with such vehicles for the 1981-85 period, 8 from the east coast and 37 from the west coast.

When the Space Shuttle becomes operational, it will be the centerpiece of the nation's space activities, both civil and military. With three liquid rocket engines that can each produce a thrust at sea level

NASA Vehicles

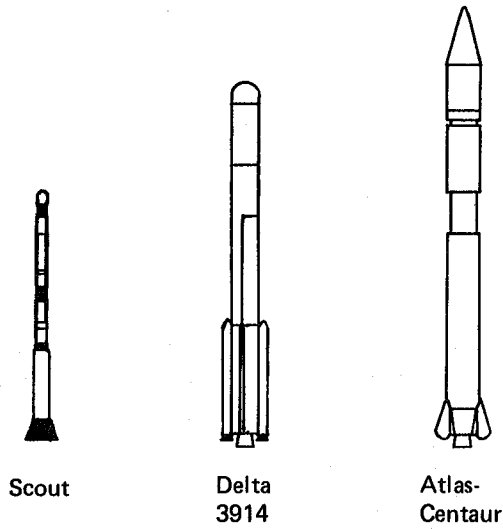

DOD (U.S. Air Force) Vehicles

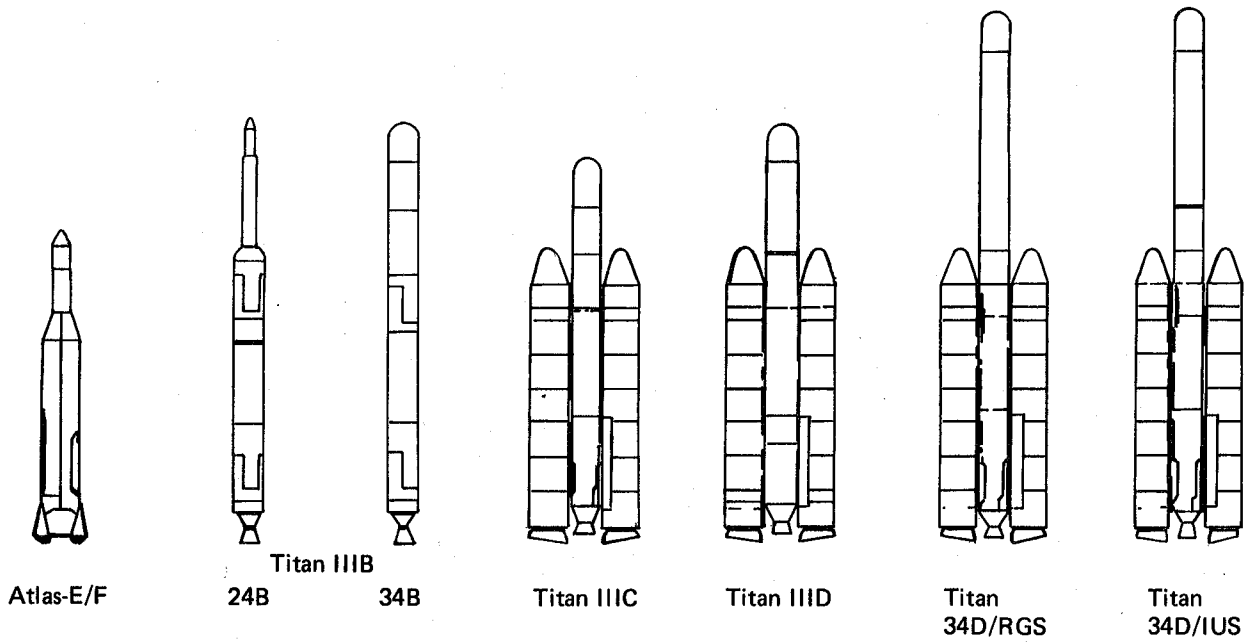

SOURCE: NASA

FIGURE 1 NASA and DOD Pre-Shuttle Launch Vehicles (NASA, 1978)

with a thrust of 2.7 million lbs each, the Space Shuttle would have a rated total thrust at lift-off of about 6.5 million lbs, enough to launch a 65,000-lb payload into low earth orbit (Figures 2 and 3).

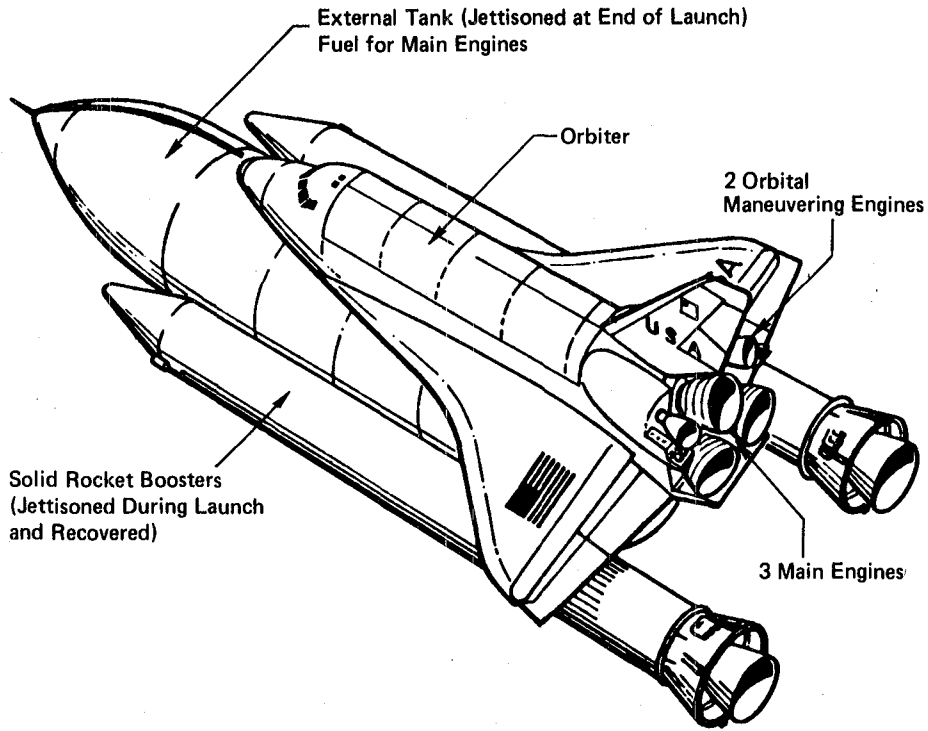

SOURCE: NASA

FIGURE 2 Space Shuttle Vehicle

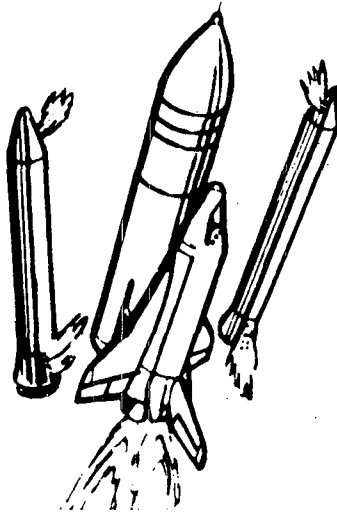

FIGURE 3 Recoverable Solid Rocket Booster Separation

## Missions Planned for Space Shuttle, 1981-1986

To take full advantage of the Space Shuttle's capability as a launch platform, a high efficiency liquid rocket upper-stage vehicle for the transfer of payloads from the Space Shuttle's low earth orbit to other and higher orbits will ultimately be required. Some upper-stage vehicles that can launch payloads into geosynchronous earth orbit (GEO) from the Space Shuttle are being readied. Plans are being made to carry two, three, and even four such vehicles on a single Shuttle flight, sometimes with low earth orbit (LEO) payloads aboard. In the meantime, studies are being made of the feasibility of using the RL-10\* (the liquid rocket motor of the Centaur) for the development of an upper-stage vehicle that can utilize the full load-carrying capacity of the Space Shuttle for a GEO mission. For planetary missions, a vehicle is now being prepared from the current generation of solid rockets.

The upper-stage vehicles currently planned for the Space Shuttle and the payloads they will be able to launch to GEO and on planetary missions are as follows:

- o The SSUS-D (Spinning Solid Upper Stage), a two-stage solid-rocket vehicle, will be able to place a 1,250-lb satellite in GEO.
- o The SSUS-A, a second two-stage solid-rocket vehicle, will be capable of placing a 2,200-lb satellite in GEO.
- o The IUS-2 (Inertial Upper Stage), a third two-stage solid-rocket vehicle, will be able to launch a 5,000-lb payload in GEO.
- o The IUS-3, a three-stage solid-rocket vehicle, will be capable of launching a 5,800-lb spacecraft on an interplanetary trajectory.\*

The NASA and DOD missions that are planned with these vehicles are designated as the Space Transportation System (STS) series. Typical NASA payloads are listed in Table 1. For comparison an upper-stage vehicle based on the RL-10 could launch a 12,000-lb satellite in GEO.

### Probable Future Missions

The questions of what are the probable future needs of both the military and civilian space programs are fundamental to making the judgments requested of this committee.

\*Subsequent to this review, on Jan. 15, 1981, NASA announced its intention to terminate its support of the stage inertial upper stage (IUS-3) for the shuttle to launch the Galileo orbiter and probe missions to Jupiter and to use a modified Centaur vehicle with its RL-10 engine instead, thus creating a need for some continued RL-10 production.

**TABLE 1 Sampling of NASA Missions Scheduled for Space Transportation System Series During 1981-86 Period**

---

*To be carried or launched by Space Shuttle in low earth orbit*

- NASA Office of Space and Terrestrial Application payload
  - Night/Day Optical Survey of Thunderstorm Lightning Experiment
  - Measurement of Air Pollution
  - Ocean Color Experiment
  - Feature Identification and Location Experiment
- Payload Deployment and Retrieval System
- NASA Office of Space Science payload
  - Various scientific experiments
- Space Telescope (to be maintained in orbit by subsequent Space Shuttle flights)
- Spacelab
  - Manned scientific laboratory with shirtsleeve working environment, built by European Space Agency
- Long Duration Exposure Facility
  - Various experiments requiring long-term exposure to space environment (to be retrieved by subsequent Space Shuttle flight)
- Multi-Mission Modular Spacecraft
  - Various instruments and observatories (to be serviced and retrieved during subsequent Space Shuttle flight)
- Get Away Special Assemblies
  - Various small self-contained experiments provided by individual investigators (to remain on Space Shuttle during entire flight)
- LANDSAT
  - Earth survey satellite incorporating Thematic Mapper and Multispectral Scanner (to replace LANDSAT now in orbit, latter to be retrieved and returned to earth)

*To be placed in geosynchronous earth orbit by IUS-2 launched from Space Shuttle while in low earth orbit*

- Four-satellite Tracking and Data Relay System for NASA use

*To be placed in geosynchronous and other earth orbits by SSUS-A and SSUS-D vehicles launched from Space Shuttle while in low earth orbit*

- Communication satellites in geosynchronous orbits
- Active Magnetospheric Particle Tracer Explorer in elliptical orbit
- Geostationary Operational Environmental Satellite
  - Weather observation and early-storm-warning satellite

*To be placed on interplanetary trajectory by IUS-3\* launched from Space Shuttle while in low earth orbit*

- Galileo Spacecraft
  - Instrumented vehicle to investigate Jupiter and its satellites
- International Solar Polar Mission
  - Instrumented spacecraft to explore the sun and its environment

---

\*Subsequent to this review, on Jan. 15, 1981, NASA announced its intention to terminate its support of the IUS-3 for these missions and to use a modified Centaur vehicle with its RL-10 engine instead.

Source: NASA (1980c).

A great deal of careful work has been done in trying to forecast the future needs of NASA. Parametric studies defining the vehicles required to launch various weights of payloads into low earth orbit, geosynchronous orbit, and planetary orbit based upon both current and forecast technology have been made.

The results of these studies for just the low earth orbit phase is conveniently pictured in Figure 4 taken from the February 1980 Status Report of the OAST Advanced Space Transportatin Working group. The lower boundary is a no-growth case and is the baseline capability of the Space Transportation System (shuttle). For this lower boundary,

**Annual Mass to Low Earth Orbit**  
**STS Baseline: 30 Metric Tons/Flight, 50 Flights/Year**

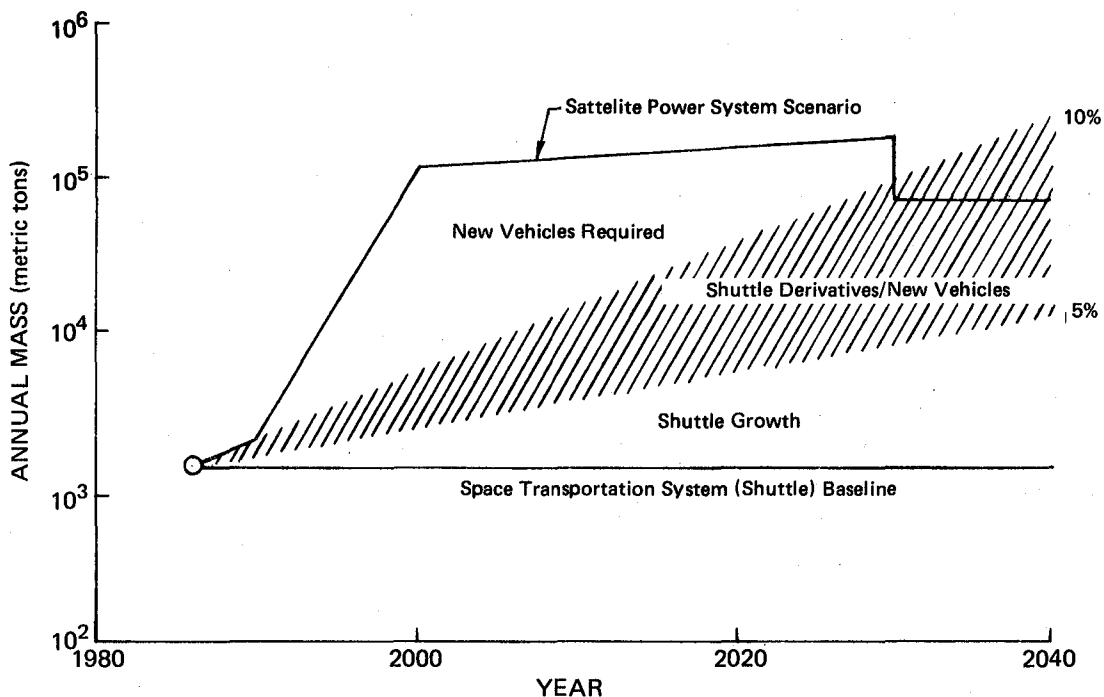

SOURCE: NASA

FIGURE 4 Space Transportation Technology Planning Scenarios

the current shuttle is projected to handle all traffic. The upper boundary represents the requirements for placement and operation of a satellite power system (SPS) with the first satellite becoming operational in the year 2000. Entirely new vehicles would be required for this mission. The shaded area represents annual rates of growth of 5 and 10 percent as experience is gained with use of the shuttle. Growth in requirements up to about 5 percent can likely be met with growth versions of the shuttle. Other studies indicate economic advantages of introducing new vehicles to achieve growth rates above the 5 percent rate.

It is clear that the space missions of the next 20 and probably 30 years are dependent on the emergence of the Space Shuttle as a reliable and effective launch vehicle.

Current planning calls for a complete phase-in of the Shuttle by 1985.

It is planned that 3 orbiters will enter launch service by 1984. These include Orbiter 102, currently under construction and development and which is the first of the line of these flight vehicles. Two other

Orbiters, 099 and 103, are scheduled to enter service in December 1982 and December 1983, respectively.

It is anticipated that by reducing structural weight of the external tank, the solid rocket booster cases, and the orbiter and by increasing engine power through improvement in the engine that the desired capability of launching a payload of 65,000 pounds to LEO, which is required for certain key missions can be attained.

From fiscal year 1981 to fiscal year 1990, a total of 380 flight missions are planned (see Table 2). Of these, 300 are to be Shuttle launched.

TABLE 2 National Flight Requirements (DOD Rev 9 28 Mar 80 NASA Data)

Launch Site	FY 81	FY 82	FY 83	FY 84	FY 85	FY 86	FY 87	FY 88	FY 89	FY 90
Eastern Space and Missile Center										
DOD - Titan	3	2	2							
- Medium Launch Vehicle	1									
- Space Transportation System (Shuttle)		1	4	3	6	8	5	9	10	12
NASA - Medium Launch Vehicle	9	5	9	2						
- Space Transportation System (Shuttle)		2	6	13	15	19	28	29	30	28
Western Space and Missile Center										
DOD - Titan	4	3	3	3	1					
- Medium Launch Vehicle	7	5	5	3	3					
- Space Transportation System (Shuttle)					3	4	6	6	8	9
NASA - Medium Launch Vehicle	3	4	1	1	1					
- Space Transportation System (Shuttle)					3	6	6	8	7	6
Combined - Titan	7	5	5	3	1					
- Medium Launch Vehicle	20	14	15	6	4					
- Space Transportation System (Shuttle)		3	10	16	27	37	45	52	55	55
TOTAL	27	22	30	25	32	37	45	52	55	55

\*NASA data modified for Oct 84 Vandenberg AFB Initial Operational Capability.

Source: USAF Space Division.

The Space Shuttle is now considerably behind schedule. This is understandable for such a completely new type of flight vehicle with new and untried concepts. Furthermore, there is little precedent for expecting the shuttle to come from the first flight to sustain high frequency launching without having to overcome difficult, unforeseen problems. It may be expected, therefore, that need will occur for a greater use of expendable launch vehicles during the early to mid-1980's.

The committee feels that since the nation's future in space is so dependent on the success of the shuttle that greater effort should be taken to ensure the improved engine performance that is needed to accomplish presently planned missions.

For the decade of the 1980's, the mission model is now well defined. However, for full Shuttle utilization, an upper stage will be needed for the rapid transfer of heavy payloads (10,000 to 12,000 pounds) into synchronous orbit and for the low acceleration transfer



of large flexible systems from assembly in low earth orbit to their operational altitudes.

The committee was briefed on studies of possible future missions involving Shuttle growth, heavy lift launch vehicles, and even single stage to orbit vehicles. Orbit transfer studies covered cargo vehicles, possibly future manned vehicles, low thrust engines for special large space structures and possibilities for reusable orbital transfer vehicles.

Based on all material available, and barring some new national program that would require a totally new vehicle such as, for example, the satellite power system, it is the committee's judgment that future missions can be accomplished by the planned growth in shuttle launch capability and an increased capability for the orbital transfer of cargo to synchronous orbit. It is clear that continued development is required for successful utilization of the Shuttle in the 1980 period and beyond.

The importance which the committee assigns to the success of the Space Shuttle program, its growth to the planned full operational capability, and the development of an orbital transfer vehicle cannot be overstated. This conviction is so strongly held that the committee's principal recommendations concern a liquid rocket research and technology development program that should be given high priority to assure this success.

## EARTH-TO-ORBIT VEHICLES

### Space Shuttle

Since the start of the U.S. space program, the missions that have been carried out have been determined largely by the rocket motors available. During the early part of the program, the motors developed for the Atlas and Titan missiles were the workhorses of NASA and DOD. Upgraded and modified, augmented at times with strap-on boosters, they have launched most of the large satellites and planetary probes that have been sent aloft by the United States. The only large rocket engines developed specifically for a non-military mission were the precursors and final version of the 1.5 million-lb thrust Saturn F-1 used for the Apollo man-on-the moon program and, subsequently, the Skylab program.

The F-1 served its purpose well but for the future the cost of space activities must be reduced.

The Space Shuttle was conceived and developed as the first step in reducing launch costs. The reusable body, with its three oxygen/hydrogen main engines, and recoverable strap-on boosters are projected to significantly decrease the cost of operations. The initial saving will be limited by the loss of the main propellant tank on each flight, the cost of refurbishing the main engines, the cost of recovering and refurbishing the strap-on boosters, and the limited 55-mission life of the reusable components, but further savings will be realized when fully reusable longer-lived components and subsystems are developed and the costs of servicing, maintenance, and inspection are reduced. Both the civil and, military space programs depend on early qualification of the shuttle and its main engine and it is the committee's opinion that the Space Shuttle and growth versions of it will provide the principal space transport for the United States for the next 20 to 30 years and that the continued development of the shuttle main engine system to achieve design performance and life is unquestionably the highest priority task in the NASA Rocket Engine program.

As of July 1980, civil and military payloads were being prepared for 90 launchings of the Shuttle over the next 4-5 years, each of the flights carrying from 1 to 4 LEO, GEO, and planetary payloads.

Technical difficulties have caused delays in the space shuttle main engine (SSME) development program. Flight certification of the engine at full power (109% rated power) has not yet been accomplished.

In assessing the technical difficulties that have been causing delays in the development and flight certification of the SSME at full power, it is important to understand that the engine is the most advanced liquid rocket motor ever attempted. Chamber pressures of more than 3,000 psi, pump pressures of 7,000-8,000 psi, and an operating life of 7.5 hours have not been approached in previous designs of large liquid rocket motors. These goals represent the creation of a high level of technology and a complex engine-vehicle flight system simultaneously.

It is unfortunate that the practice usually followed in the development of aircraft and rocket engines was sidestepped during the development of the SSME in an effort to save time. The design of the engine system before completion of R&D programs on the pumps, turbines, controls, and other major components is largely responsible for the costly failures and delays in the program.

Understandably, the primary focus of the Space Shuttle program is still on the problems that stand in the way of achieving an operational capability with the initial version of the Shuttle but the committee recommends a significantly broader program. The committee urges the parametric characterization of the main engine system and its components in order to establish the technical foundation needed to make the fixes and improvements that will be required during the balance of the program. If this is not done, the billions of dollars being spent on the Shuttle will not benefit the rest of this program and future projects.

It is also urgent that a program be established as soon as possible for the testing of all the flight-type hardware over the operating range. There is no other rational way of evaluating failures or estimating the success of an improved or new design. Such tests should be fully instrumented to measure and record all the gross and detailed data required for a full analysis and understanding of the operating characteristics of the SSME and its components.

Also required at the present time is a clear statement of the program contemplated for the development of the SSME during the 1982-85 period and beyond. NASA's goal is the achievement of full power operation by 1982 and an operating life of 7.5 hours (55 starts) during 1982-85 but the level of funding and methods to be used to reach these goals do not appear to have been worked out. If, as NASA indicates, the first 300 missions will be accomplished with four Space Shuttle vehicles, a rapid improvement in the operating life of the SSME is essential. The level of funding will be critical. Experience has shown that the funds required after qualification of an engine usually exceed those spent in reaching it. The committee believes that it is time for NASA to develop a program for the continued development of the SSME beyond 1982. In recognition of the importance of the Space Shuttle to the future of space activities by the United States, the committee concludes as follows:

1. The continued development of space shuttle main engine is the highest priority task of the NASA liquid rocket program.

2. NASA should initiate a test program to measure the characteristics of the principal SSME components over a wide range of operating variables.
3. A program should be initiated to recover technological data created in the SSME program which has up until now not been adequately reported.
4. Planning and budgeting for SSME continued development after 1982 should be initiated, including consideration of methods for upgrading the shuttle performance.

#### Projected Vehicle Needs

The Mission Models data presented by NASA were reviewed to determine the basis for new Earth-to-Orbit (ETO) vehicles having capabilities beyond the Shuttle and its generic enhancements. Of special interest was whether the information is "convincing" on:

1. The realism of the advanced missions and time scales
2. The value (performance gains and cost effectiveness) of proposed new vehicle configurations.

Such information was used to provide a framework for assessing the importance and prioritization of the various technology program elements presented, and the realistic dates by which such "enabling" technology to support propulsion system development programs for each new vehicle would be needed.

The information presented indicates:

1. For slow growth in the demand for annual payload weight delivered to low-earth orbit (up to about 5%), enhancements to the Shuttle capabilities currently envisioned would probably suffice.
2. For larger growth in orbit weight per year (up to about 10%), development of new vehicles based in part on Shuttle technology may be cost effective.
3. For new mission concepts requiring very large weights per year, new, very heavy launch vehicles would be necessary.

Considerations of the reality and time schedule of the third category of missions (e.g. Satellite Power System) and, therefore, of the need for a very large launch vehicle (Heavy-Lift Launch Vehicle, HLLV) do not justify any significant technology development effort in the foreseeable future. However, any effort that would provide the basic engineering data and design criteria for the engines and propulsion system of the proposed nearer-term enhancement of the shuttle and possible derivative vehicles would be directly useful for any future very large heavy-lift launch vehicles.

A follow-on of the Space Shuttle might be an intermediate-lift launch vehicle that is capable of launching LEO payloads of up to a few hundred thousand pounds and commensurate GEO and planetary payloads. As a basis for its research and technology development program, NASA envisions a  $\text{LO}_2$ /hydrocarbon motor with a lift-off thrust of 500,000-600,000 lbs that could be clustered to provide the first stage of such a vehicle and the use of a cluster of the  $\text{LO}_2/\text{LH}_2$  SSMEs to power the second stage. Other options are being studied, including the development of a motor with two stages of operation that, clustered, could power a single-stage-to-orbit (SSTO) vehicle.

### Single-Stage-to-Orbit Vehicles

A chart presented by NASA and reproduced in Figure 5 depicts the cost of payload into low earth orbit in \$/Kg versus operational date.

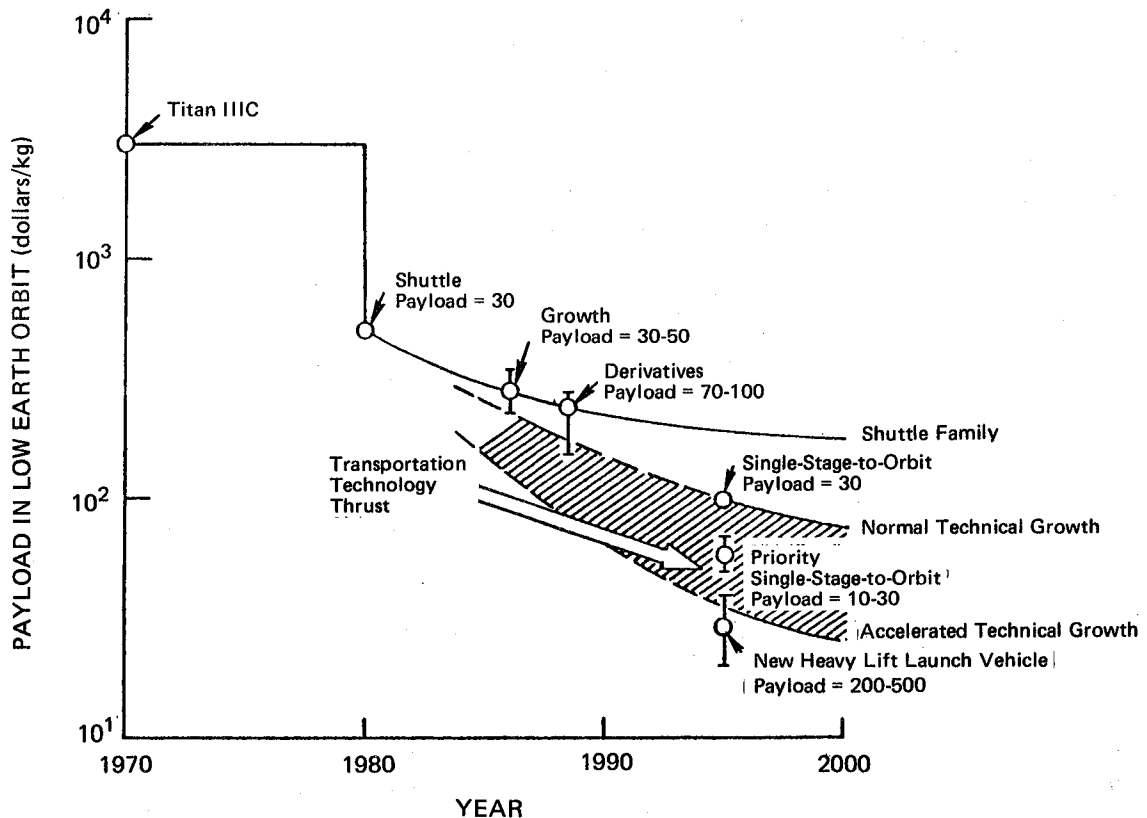

SOURCE: NASA

FIGURE 5 Low Earth-Orbit Transportation Costs-Payloads in Megagrams (Metric Tons)

A list of advantages for single-stage-to-orbit vehicles was presented. Some of the most important from a cost point of view are:

- o No expendable hardware
- o Simplified logistics
- o Reduced ground turnaround operations
- o Single vehicle and engine development

Such a vehicle would be sophisticated far beyond the existing Shuttle. Since it must carry all of the inert mass of the hardware associated with the propellants required for producing a velocity of 29,000 ft/sec all the way to orbit, the sensitivity to structural design, thermal protection, protection systems, engine performance, etc., makes the validity of assumptions and the quality of design data very important.

The engines required for a Single-Stage-to-Orbit vehicle could operate entirely on LOX + H<sub>2</sub>, or a sequence of LOX + RP-1 or LOX + CH<sub>4</sub> and then LOX + H<sub>2</sub>. NASA has proposed the need to develop technology for a dual-fueled engine for Single-Stage-to-Orbit vehicles. This proposal is based on vehicle performance analysis which indicates advantages of higher mass fraction (propellant density) for the first part of the trajectory (high drag - low acceleration portion) and then a switch to a propellant with a higher specific impulse after a certain acceleration (ΔV) has been achieved. For any given set of propulsion parameters there would certainly be such an optimum mix of propellants; providing the specific impulse of the high density fuels is not too low. The data presented in Figure 6 indicates that dual-fueled engines compared with a LOX + H<sub>2</sub> system have a potential for a 20% lower cost. However, a parallel-burn dual engine-configuration provides essentially the same overall projected cost saving without the dual-fuel complexity.

Therefore, the requirement for a dual-fueled engine development is open to question.

It should be noted that data presented to the committee showed LOX + RP-1 engines for Single-Stage-to-Orbit targeted to operate at 4000 psi chamber pressure in order to support the performance estimates. This is most doubtful for fuels such as RP-1. It may be achievable with CH<sub>4</sub>.

Discussion with NASA propulsion experts indicates that the engine and propulsion system design and performance assumptions used for some of the new vehicle system analysis may not have had the necessary expert opinion and evaluation needed to assure a consistent basis for comparison of performance potential and development costs among the various options. It is the opinion of the committee that the cost reductions to be made by technology growth, illustrated in Figure 5 appear highly qualitative and assertive. An on-going, in-depth review of such studies by a broad spectrum of NASA engineering specialists would seem warranted. Critical evaluation is necessary before any work related to such vehicles is undertaken.

It is the consensus of the committee members that any extensive technology work related to "Dual-Fueled Engines" is premature and is not recommended. To do useful work on this concept requires complex and fairly large combustion chambers and breadboard engines to provide

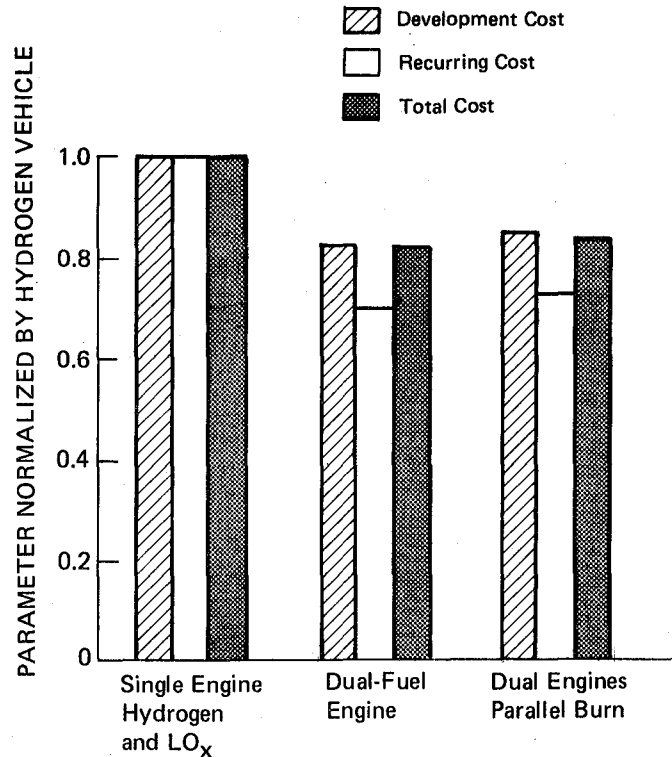

SOURCE: NASA

FIGURE 6 Cost Comparison of Concepts

any real credibility. This will be very expensive if any timely progress is to be made and should await a much more definitive need.

After examining the studies NASA has made, the committee does not find that a convincing case has been made for any of the Single-Stage-to-Orbit options considered.

#### Heavy-Lift Launch Vehicles

To launch LEO payloads of up to 1 million lbs (and commensurate GEO and planetary payloads), NASA envisages the development of a 2-million-lb thrust liquid-fueled motor that can be clustered to produce the lift-off thrust required for the first stage of such a vehicle (see Figure 7). The second stage could be a cluster of Space Shuttle main engines (SSMEs), or a cluster of the motors developed for the first stage of an intermediate-lift launch vehicle. Heavy lift launch vehicles (HLLVs) could be designed so that all or only parts of the vehicle are recoverable and reusable.

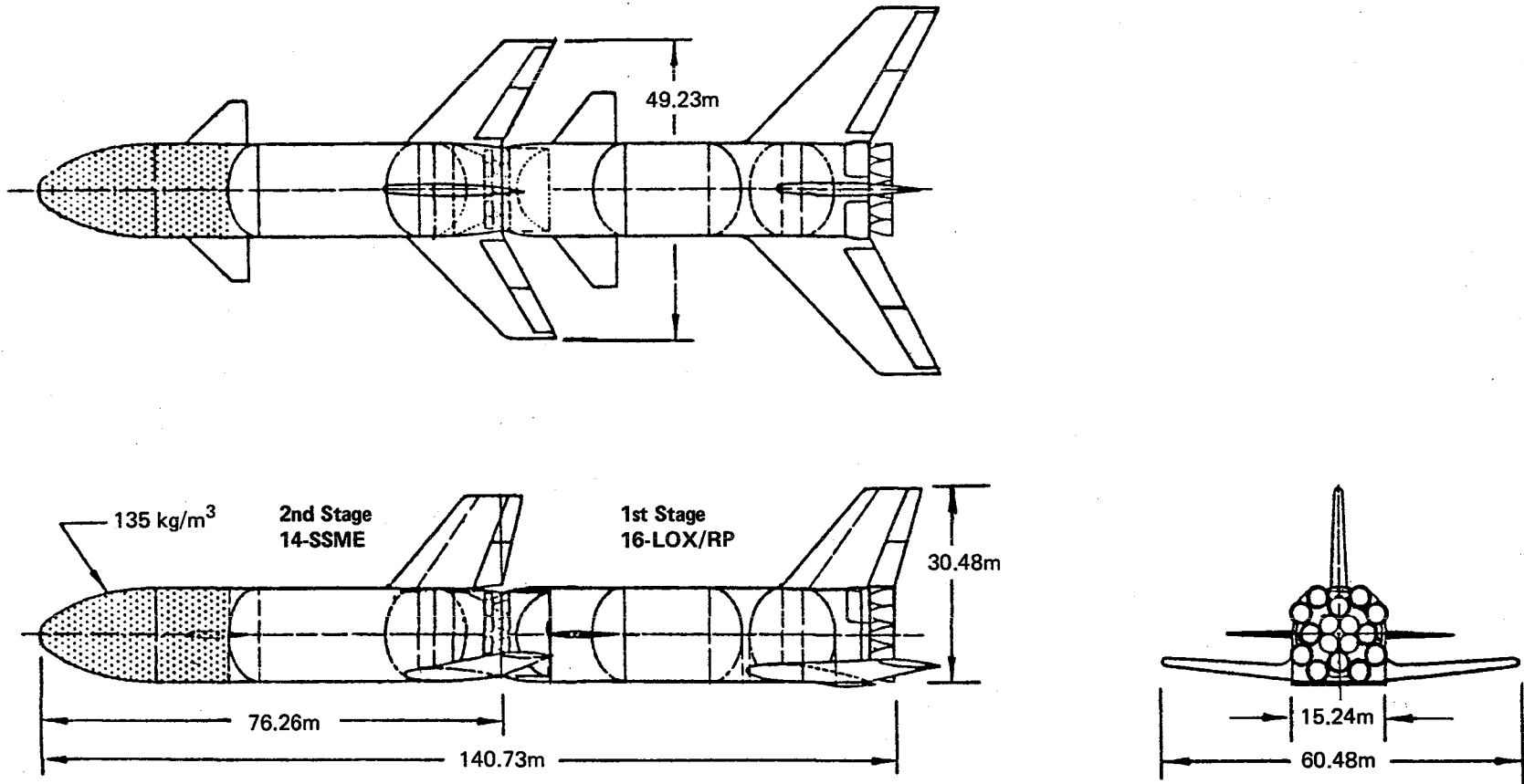

SOURCE: NASA

FIGURE 7 Possible Configuration of Heavy-Lift Launch Vehicle



In nearly every configuration considered, NASA has indicated the desirability of a LO<sub>2</sub>/hydrocarbon first stage and LO<sub>2</sub>/LH<sub>2</sub> second stage. The use of LO<sub>2</sub>/LH<sub>2</sub> for both stages would result in larger (but lighter) vehicles and, according to NASA estimates, a 50 percent increase in operating costs. When a comparison is made of the vehicle plus propellant costs for a 15-year program involving LEO payloads totaling 125,000 metric tons/yr. however, the cost differences become narrower and, at higher staging velocities, become ambiguous (Figure 8). NASA should more firmly ascertain the advantages of a LO<sub>2</sub>/hydrocarbon motor over a LO<sub>2</sub>/LH<sub>2</sub> motor for the reusable first stage of a HLLV. Reliability, simplicity, and environmental effects should be considered along with development and recurring costs before an extensive R&D program is started. LO<sub>2</sub>/LH<sub>2</sub> may prove to be the best choice for all future propulsion systems.

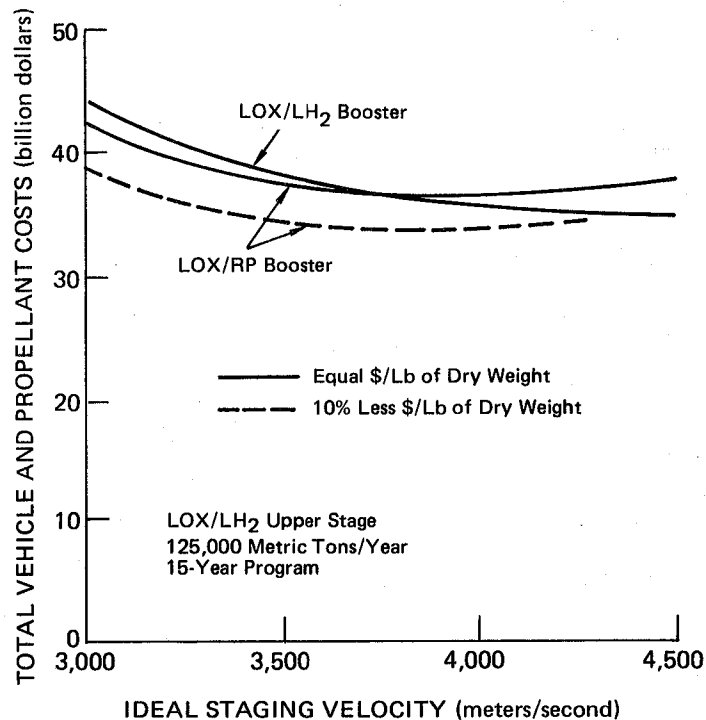

SOURCE: NASA

FIGURE 8 Total (vehicle and propellant) Costs for 2-stage High-Lift Launch Vehicles during 15-year Program

If a careful study of all the factors involved does indeed support the case for a LO<sub>2</sub>/hydrocarbon motor, the next question to be resolved is whether the hydrocarbon should be RP-1 or CH<sub>4</sub>. The optimum operating conditions could be different with each, leading to different technological problems. Comparisons of propellant systems

must take into account any limitations that might be placed on the operating range of the motor by coking, pump cavitation, the heat transfer characteristics of the propellants, etc. Where the limitations are not already known, preliminary investigative work may be needed to enable the selection of the propellant system with the greatest potential.

### Integrated Orbit Maneuvering and Reaction Control System

Another need for propulsion included under the Earth-to-Orbit Technology Plan relates to advanced auxiliary propulsion systems: the Orbit Maneuvering and Reactions Control systems of the Shuttle. The LOX-Hydrocarbon fuels are also attractive for this class of propulsion system as a replacement for the nitrogen tetroxide-monomethylhydrazine propellants currently used in the shuttle. Oxygen-Hydrocarbon fuel offers higher performance and would circumvent potential environmental and safety issues related to the production of monomethylhydrazine and avoid its increasing cost.

The program as described calls for conducting all of the system studies and analysis needed to select the "best" propellant combination and operating conditions. The detailed component and breadboard technology program would then be defined.

The system studies to be carried out first should select both the propellant combination ( $O_2 + CH_4$  or  $O_2 + C_3H_8$  or  $O_2 + NH_3$  or  $O_2 + RP$ ) and the operating conditions and system design. The technology work would then be undertaken on the selected propellants to verify combustion performance, oxidizer and fuel handling and insulation, carbon formation, heat transfer, etc. The final phase of the program would be a breadboard integrated system evaluation. This appears to be a good program which will provide data of interest to systems beyond the Shuttle's orbiting maneuvering system and reaction control system.

### Technology Needs and Conclusions

One objective of the proposed earth-to-orbit vehicle technology program is to develop analytical techniques, and develop design models and design procedures for launch vehicle engines and propulsion systems. One product would be a set of computerized models that could simulate component and system performance. These models and data would be important to aid in determining vehicle performance and in making propellant selections. Much of the input data for LOX and hydrocarbons are known from past experience. This experience has been summarized in the many "Design Criteria" documents that NASA has assembled and published during the past 10 years. By relating this available engineering criteria to the selected, advanced propulsion system requirements, gaps in the criteria at needed extensions can be identified. Any technology programs related to LOX + Hydrocarbons should then be defined to determine these basic and generic design criteria to fill the gaps. This type of fundamental technical data will be applicable to almost any new LOX + Hydrocarbon rocket propulsion engine design at any scale.

The results of NASA's "Fundamental Discipline Research" will extend the generic design criteria data base for hydrocarbon propellants to

ranges of most interest for possible future booster vehicles. In the schematic outline of Liquid Rocket Propulsion System Evolution (see Figure 9), such work is a logical starting point. With this type of

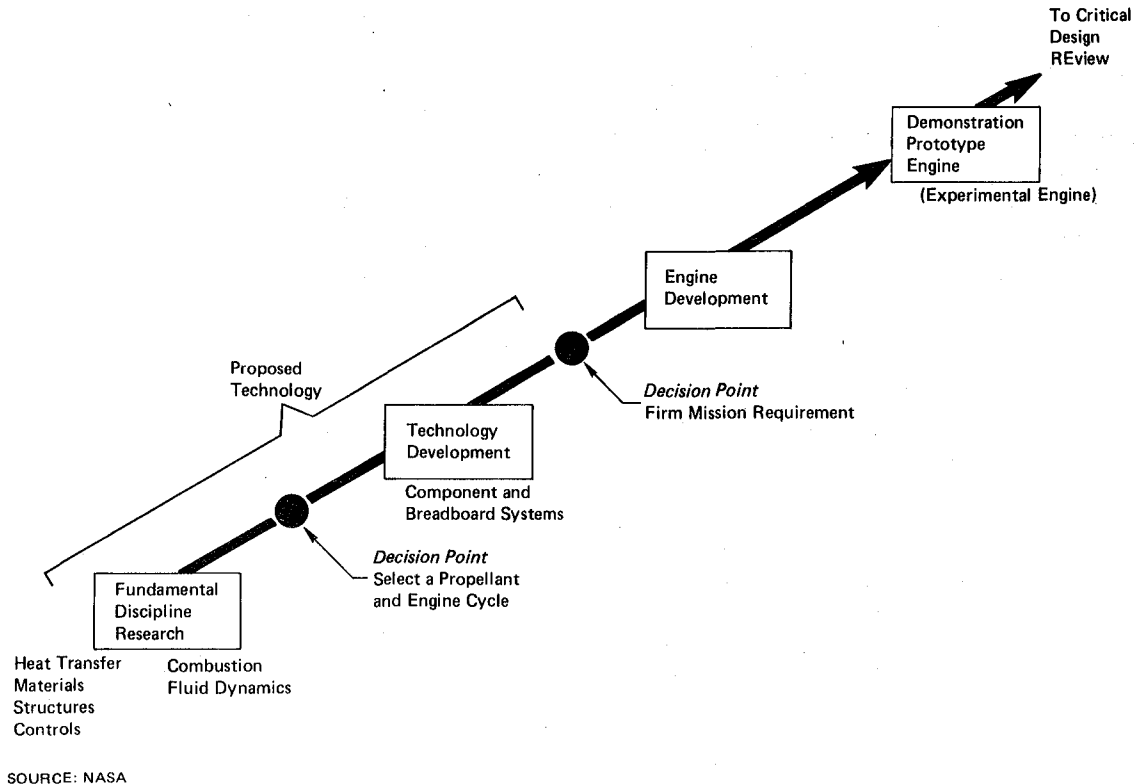

FIGURE 9 Liquid Rocket Propulsion System Evolution

data to provide basic operating limits and the propulsion system models discussed earlier, the combination having the most potential for major performance improvement and lowest net amortized cost for advanced missions could be selected. Any future Technology Development Phase should be undertaken with only the selected system and engine cycle concept. The important issues to resolve early are:

- o The highest performance potential engine cycle for both LOX + RP-1 and LOX + CH<sub>4</sub>
  - Gas Generator Cycle
  - Staged Combustion Cycle
- o The most cost effective and technically feasible operating pressure for each propellant combination (probably very different for RP-1 and CH<sub>4</sub>)

- o The maximum turbine inlet temperatures achievable with controlled gas properties
- o The optimization of regenerative cooling regimes for maximum future engine cycle life.

This information along with already known criteria will serve not only to permit selection of propellants between RP-1 and CH<sub>4</sub>, but also resolve the comparative performance between LOX + H<sub>2</sub> and the two hydrocarbons.

Most of the remaining technology work described by OAST (see Figure 10) would be generically useful for designing any advanced engine cycle at any scale, e.g.:

- o Turbomachinery Dynamics
- o High-Temperature Turbine Cooling
- o Long-Life Bearings and Seals
- o Combustion Characteristics at Off-Mixture Ratio Conditions
- o Maintainability

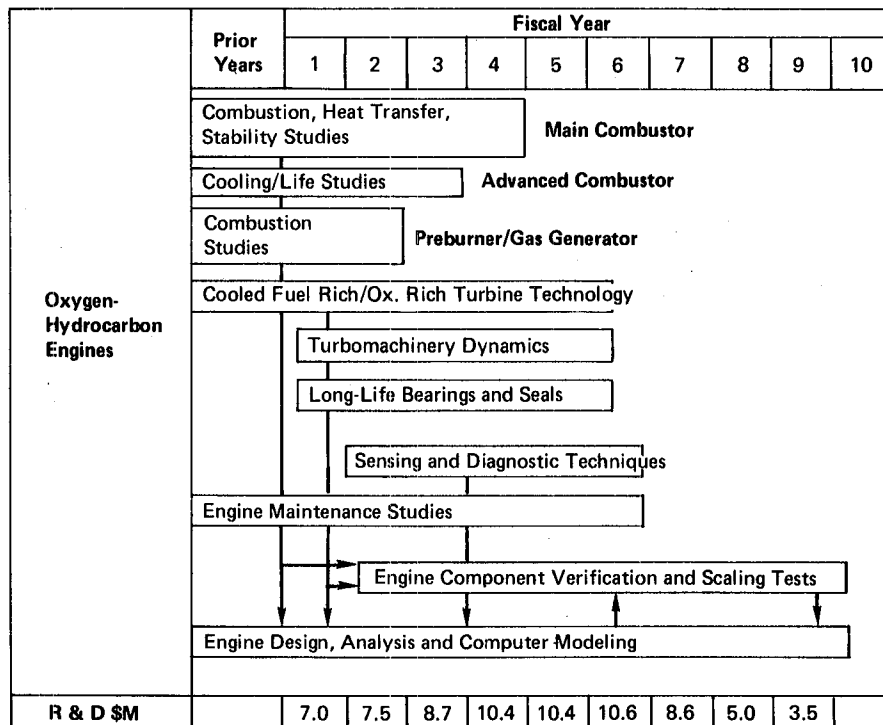

SOURCE: NASA

FIGURE 10 Earth-to-Orbit Vehicle Propulsion

**This Page Intentionally Left Blank**

## ORBITAL TRANSFER VEHICLES

According to present planning, the full potential of the Space Shuttle for launching payloads to geosynchronous or other high orbit and escape payloads, will not be realized until a new upper-stage vehicle is developed in the late 1980s. In the meantime, NASA will use four available solid rockets with the Shuttle for launches to geosynchronous earth orbit (GEO) and planetary launches: two Spin-stabilized Upper Stages (the SSUS-D and the SSUS-A, capable of launching GEO payloads of 1,250 and 2,200 lbs) and two Inertial Upper Stages (the IUS-2, capable of launching GEO payloads of 5,000 lbs, and the IUS-3, capable of launching a 5,800 lb spacecraft on an interplanetary trajectory) as described in the section on MISSION MODELS.

Despite the relative simplicity and reliability of the solid rocket vehicles, there are no plans for developing larger ones for upper-stage vehicles. Liquid rockets have better performance characteristics and their start-stop capability makes them more versatile.

It is anticipated that new orbital transfer vehicles will be needed by the late 1980's or early 1990's for two types of missions:

- o The rapid delivery and/or retrieval of manned and unmanned satellites.
- o The relatively slow transfer to geosynchronous orbit of large space structures that are first assembled or deployed in low earth orbit.

NASA is using two concepts of orbital transfer vehicles as a basis for planning its research and technology development program. The first involves a dual-thrust liquid rocket motor that would operate at two different thrust levels, producing a high thrust for normal GEO payloads and a low thrust for low acceleration transfer of large structures. The other approach involves the development of two separate motors, one for each type of mission.

## Dual-Thrust

The objective of NASA's dual-thrust orbital transfer vehicle propulsion program is the development of a LO<sub>2</sub>/LH<sub>2</sub> motor that will produce thrusts of 15,000 lbs and 1,500 lbs. The agency plans to carry two somewhat different designs to the breadboard stage before deciding which to use. One is a new dual thrust engine based on the expander cycle similar to the RL-10, the motor developed for the Centaur. The other, builds on technology developed in the advanced high thrust (20,000 lbs., LO<sub>2</sub>/LH<sub>2</sub>) engine technology program for a future new engine with appropriate modifications to permit operation at thrust levels as low as 2,000 lbs. The status of the advanced high thrust engine technology program is that many of the components have been tested individually and tests as a breadboard assembly have been proposed.

## Separate High-Thrust and Low-Thrust

In this approach, NASA envisages a high-thrust vehicle with a thrust of 15,000 lbs and a low-thrust vehicle that has a thrust of 100 to 2,000 lbs and a burn-time of as much as 40-50 hours. The high-thrust vehicle would be the engine to develop from the advanced high thrust engine technology program mentioned above. The low-thrust vehicle would necessitate a new development program.

The technology base required for the design of a low-thrust long-burn-time system is quite different from the technology base established for the systems developed to date. A number of unique problems are going to be met, particularly (a) the boiling of cryogenic propellant in small feed lines at low flow rates, (b) the cooling of small combustors, and (c) the fabrication and efficient operation of small pumps and other small mechanical parts. If the boiling of liquid hydrogen proves to be too great a problem, it will be necessary to consider hydrocarbons as fuels. These problems are discussed more detail in the FUNDAMENTAL TECHNOLOGY PROGRAM section of this report.

## Comparison of Concepts

The two proposed programs represent a sound technical approach to achieving the cited goals. However, after comparison of the results of the systems analyses presented with the capabilities of the RL-10, it is the committee's conclusion that the pre-qualification of an upgraded model of the RL-10 should take priority over the proposed technology programs, especially over the dual thrust program. This upgrading of the RL-10 would achieve an increase in specific impulse (ISP), demonstrate longer life at both high and low thrust, and assess redundancy additions for improved reliability and man rating. The low thrust propulsion program seems to hold promise for vehicles for changing the orbits of large, flimsy space structures. The systems analyses referred to are the results of many studies, both within NASA and by contractors. The analyses addressed two separate points:

1. What are the payload advantages of the advanced high pressure staged-combustion engine (ISP = 476 secs) mentioned above vs.

the basic RL-10 as it is today (ISP = 438 secs) or the improved RL-10 (ISP = 460 secs). Several mission scenarios were considered:

- a) Deploy the payload to geosynchronous (GEO) altitude and expend the stage;
- b) Deploy the payload to GEO and return the stage to low earth orbit (LEO) for recovery and re-use; and
- c) Deploy the payload to GEO and return the payload to LEO as required for a manned GEO mission. Table 3 is representative of the results for a 65,000 lb payload shuttle and one excursion to a 100,000 lb payload shuttle.

TABLE 3 Geosynchronous Payload Capabilities of 15,000-lb Thrust Orbital Transfer Vehicles

Engine	Specific Impulse (sec)	Payload Delivered OTV Expended	Payload Delivered OTV Returned	Payload and OTV Returned	Payload and OTV Returned with Aero-assisted Braking
<i>Launch vehicle: Space Shuttle with 65,000-lb LEO payload capability</i>					
RL-10	438	15,200	5,000	1,600	
RL-10 IIB	460	16,750	6,600	2,100	
Advanced high-performance engine	476-480	17,630	8,200	3,000	
<i>Launch vehicle: Space Shuttle with 100,000-lb LEO payload capability</i>					
RL-10	438			5,000	
RL-10 IIB	460			7,000	13,000
Advanced high-performance engine	476-480			9,000	15,000

Source: NASA (1980b).

2. For the delivery of large space structures to GEO which have been pre-deployed at low earth orbit (LEO) to assure their integrity, what is the tradeoff between increasing the weight of the structure to withstand the relatively high accelerations developed using a high thrust (15,000-20,000 lb) engine vs. reducing the thrust to (200-2000 lb) and lightening the structure? A further refinement of this systems analysis assesses the gain in size of a large structure achieved by developing a new efficient low thrust engine (ISP = 450, T = 570-217 lb) vs. using the RL-10 in the pump idle mode (ISP = 433 sec, T = 1500 lb) or the tank idle mode (ISP = 400, T = 192 lb).

Referring to Table 3, it is seen that the gain in payload between the existing RL-10 and the advanced high thrust technology engine is quite small for the most probable near-term use of an OTV to deliver the payload to GEO and expend the OTV. Both provide substantial increases in payload over the IUS (5,000 lbs.) For the case of delivering the payload and recovering the OTV, some payoff of higher ISP is indicated. Finally, for the round-trip manned GEO mission, the 65,000 lb shuttle simply cannot deliver sufficient payload (13,000 lbs payload



required for a manned mission) from a single shuttle launch. However, for an upgraded 100,000 lb payload shuttle and the use of aero-assist braking of the OTV, manned GEO missions become feasible. The gain in performance between the improved RL-10 and that calculated for an advanced high thrust engine for this mission is only about 15 percent (2000 lb). By comparing the last two columns it is clear that development of aero-assist braking for recovery provides a large payoff.

Referring to Table 4, a 40 percent larger pre-deployed structure area can be delivered to GEO from LEO by a dedicated new low thrust engine compared to using the RL-10 in the tank-idle mode. In both cases, however, the structures are extremely large (300 ft x 600 ft) so that substantial capability is achieved using either engine.

TABLE 4 Geosynchronous Space Structure Capabilities of Low-Thrust Orbital Transfer Vehicles

Engine	Specific Impulse (sec)	Thrust (lbs)	Burn Time (hrs)	Payload Weight (lbs)	Payload Area (sq ft)
RL-10 in low-thrust (pump-idle) mode	433	1,500	8	12,874	117,800
RL-10 in low-thrust (tank-idle) mode	400	192	80	11,775	174,000
Advanced high-performance low-thrust engine	450	570-217	75	15,255	240,000

Launch vehicle is early version of Space Shuttle with 65,000-lb LEO payload capability. Entire payload (space structure) carried on launch (not previously deployed or assembled in low earth orbit). Much larger space structures can be launched if they are first deployed or assembled in low earth orbit and the full payload capacity of the Space Shuttle is then used to launch an OTV with large propellant tanks.

Source: NASA (1980b).

Table 3 shows the payloads that can be lifted into geosynchronous orbit by a 15,000 lb thrust OTV (either a high-thrust OTV or a dual-thrust OTV operating in the high-thrust mode). The table shows the sizes of the payloads when:

- o The OTV is based on the use of the present RL-10, an advanced RL-10 (RL-10 IIB), or the advanced high-performance motor.
- o The launching vehicle is an early version of the Space Shuttle, capable of lifting 65,000 lbs into low earth orbit, or a later version of the Shuttle, capable of lifting 100,000 lbs into low earth orbit.
- o The OTV is expended (left in orbit)
- o The payload is delivered (left in orbit) and the OTV is returned.
- o Both the payload and OTV are returned by retrofiring the OTV.
- o Both the payload and OTV are returned by retrofiring and aero-assisted braking using vehicles like those shown in Figure 11. Payload capabilities of this order (13,000-15,000 lbs) would enable manned GEO missions.

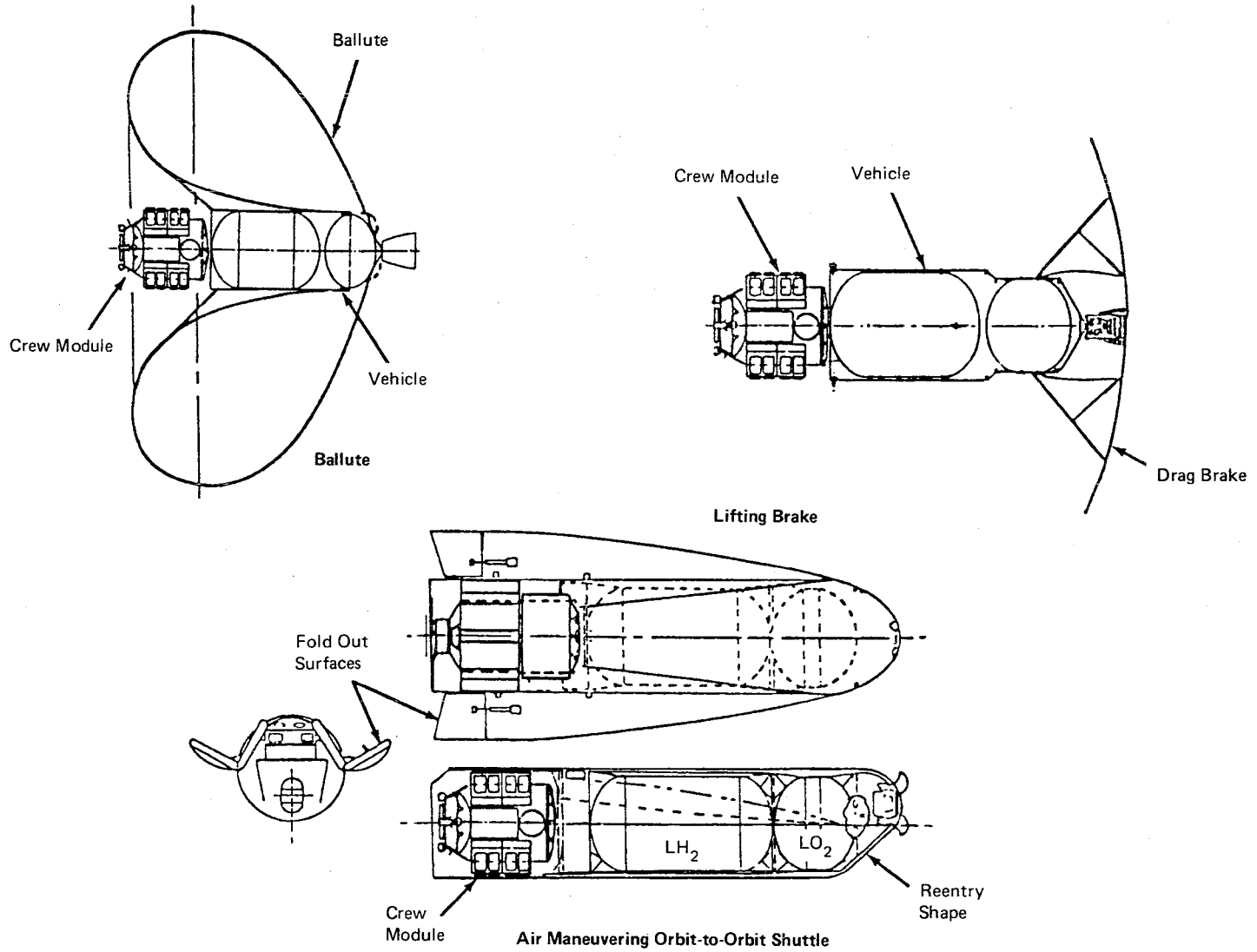

SOURCE: NASA

FIGURE 11 Aeroassisted Orbital Transfer Vehicle Configurations

Table 4 and Figure 12 show the sizes and configurations of some large space structures that can be launched into geosynchronous orbit with an early version of the Space Shuttle (65,000-lb LEO capability) and the following OTVs:

- o An OTV with a RL-10-based dual-thrust motor operating in a low-thrust (1500 lb) mode.
- o An OTV with a RL-10-based dual-thrust motor operating at a lower thrust (192 lb).
- o An OTV with an advanced high-performance single-thrust motor producing a thrust in the 217-570 lb range.

These calculations, provided by NASA, are based on an expendable (non-returnable) OTV. It should be noted that a reduction in the thrust of the RL-10-based OTV from 1500 lbs to 192 lbs makes it possible to lift a structure with a larger area into geosynchronous orbit since, with a lower acceleration, the structure can be less rigid.

Although there are some advantages to separate high-thrust and low-thrust motors of advanced design, the committee believes a major step in capability can be achieved by going to a LO<sub>2</sub>/LH<sub>2</sub> stage based on the existing RL-10 and an improved RL-10 II B. Top priority should be given to the modification of the RL-10 for a dual-thrust OTV since it is already available and has been operated with complete reliability during 10,000 test firings (a total operating time of about 25,000 minutes) over a 1500-21,000-lb thrust range.

The committee recommends that NASA immediately pursue a prequalification program for the improved RL-10 IIB at both high and low thrust. A second priority would be to pursue the proposed low thrust engine program. This approach has the virtue of affording the option of significant increase in orbit transfer capability in the 1980's at minimum development cost as compared to the long, high cost development of new engines.

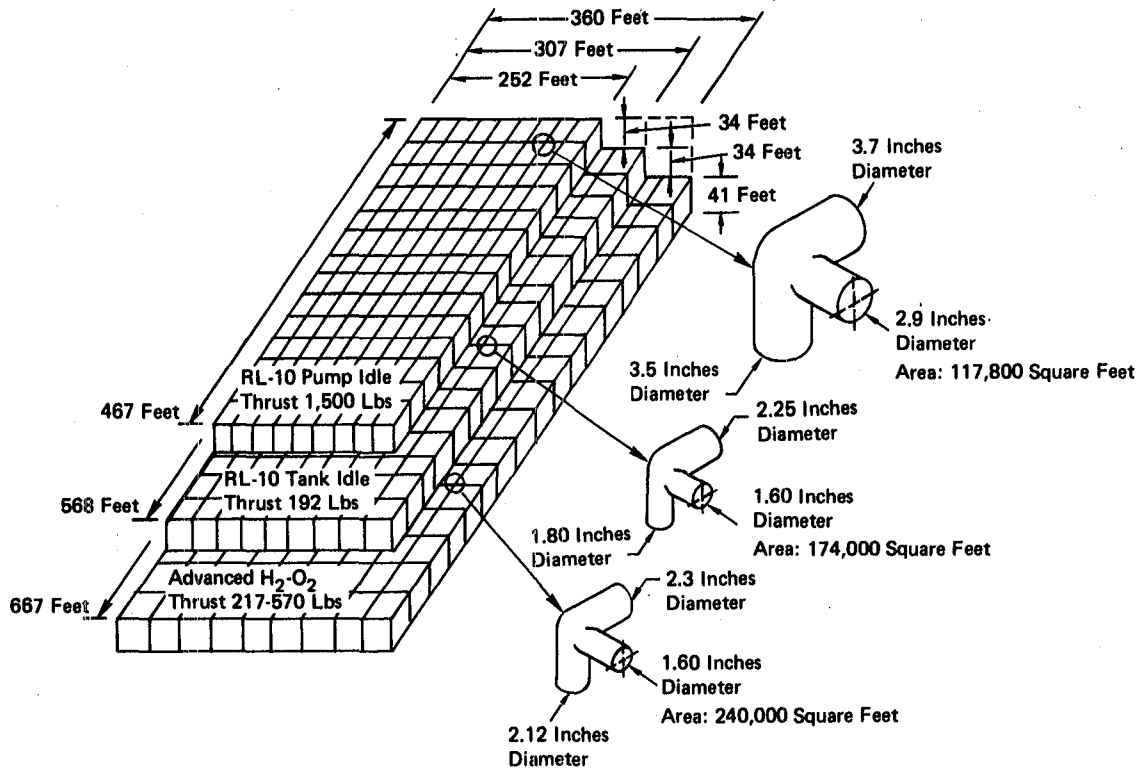

SOURCE: NASA

FIGURE 12 Geosynchronous Space Structure Capabilities of Low-Thrust Orbital Transfer Vehicles

**This Page Intentionally Left Blank**

## PLANETARY SPACECRAFT RETRO-PROPULSION SYSTEMS

Planetary missions of the future will be governed by the capabilities of the retro-propulsion systems developed for this type of mission. New concepts that can reduce the weight and improve the performance of planetary spacecraft will enable the launching of payloads that are increasingly large, sophisticated, and complex (orbiters, probes, and landers, as well as spacecraft that can return material samples to earth).

The retro-propulsion for NASA's recent Mars Viking Orbiter/Lander was provided by an earth-storable pressure-fed system using nitrogen tetroxide ( $N_2O_4$ ) and monomethylhydrazine (MMH). The propellant combination accounted for 40 percent (3100 lbs) of the total weight of the orbiter/lander at launch, most of it being required for the short bursts used for orbit trim and other orbital maneuvers. For more demanding missions, propellant weights for this type of system would be prohibitive.

Two approaches to this problem are being studied. For the near term, NASA is considering a pressure fed fluorine/hydrazine system that can improve the propulsion performance by 25-30 percent over the nitrogen tetroxide/MMH system. For future spacecraft, the agency is considering lighter-weight pump-fed systems that will improve the performance (system weight) by another 20-25 percent. Since all the propellants required for retro-propulsion must be accelerated to escape velocity, every improvement will have a highly leveraged effect on costs and/or payloads.

### Pressure-Fed Systems

The performance and operational capability of a pressure-fed fluorine/hydrazine retro-propulsion system is being evaluated in a demonstration program that was begun by NASA in 1977, after several years of basic work on the technology of fluorinated oxidizer propulsion.

Tests are being carried out under simulated space conditions of a complete near-flight-weight assembly that includes a motor, propellant tanks, tank pressurization systems, and a propellant distribution

system. The motor is designed for a thrust of 800 lbs, a specific impulse of 370 sec, 50 start-stop cycles, and burn times of up to one hour.

### Pump-Fed Systems

A demonstration program for pump-fed fluorine/hydrazine retro-propulsion systems is not likely to be started until the pressure-fed fluorine/hydrazine system is further along. In the meantime, some basic preliminary work is being done on pump-fed systems using earth-storable propellants.

#### Assessment of Planetary Retro-Propulsion Program

Experience with liquid fluorine systems has shown fluorine under pressure to be highly unpredictable and exceedingly destructive. While the NASA program has been carried out very carefully, the committee has grave reservations about the use of liquid fluorine as a propellant, particularly when it is to be used in a spacecraft carried on the Space Shuttle. The risk to the personnel on the Shuttle, to say nothing of the damage that could be done to highly expensive equipment, is substantial and, in the committee's view, it is unacceptable and unwarranted.

Liquid fluorine can ignite a variety of metals, and does so with increasing unpredictability as its pressure and dynamic activity are increased. Successful tests with one or two sets of hardware are no guarantee that tests with the next set will not end in disaster. And if, when a failure does occur, an attempt is made to correct the design, the very unpredictability of liquid fluorine will make the determination of reliability a prohibitively expensive statistical process.

The committee recommends extensive studies of other high-energy propellant combinations (e.g.,  $O_2/CH_4$ ,  $O_2/C_3H_8$ ,  $O_2/N_2H_4$ , and  $NF_3/N_2H_4$ ) and, at the same time, the development of small pumps that can provide weight-saving advantages over pressure-fed systems. A program directed to the development and demonstration of an optimal safe-propellant pump-fed system offers a number of advantages:

- a) a higher probability of success
- b) a lower cost, and
- c) a more readily acceptable end-product.

## FUNDAMENTAL TECHNOLOGY PROGRAM

A broad fundamental technology base is required for the design and development of the vehicles that are going to carry the U.S. space program through the decades ahead.

NASA's basic research program is being carried out in six areas:

- o Pumps and pump drives
- o Combustion
- o Heat transfer
- o Nozzle aerodynamics
- o Low-gravity cryogenic fluid management
- o Component and system life, reliability, and maintenance.

The work being done in each of these areas, the deficiencies of the programs, and the problems being faced are described below.

### Pumps and Pump Drives

The primary emphasis in this area is on cryogenic pumps for low-thrust motors for orbital transfer. To date, studies have been carried out on six types of displacement pumps and six types of dynamic pumps (Aerojet, 1980; Rocketdyne, 1980).

The studies show that positive displacement pumps are more efficient over their entire operating range than dynamic pumps for the pumping of liquid hydrogen, but their performance diminishes with time due to the wear of seals and bearings. The life and reliability of the dynamic pumps are superior.

Each of the dynamic types appears suitable for particular applications; centrifugal pumps have acceptable efficiencies at low heads and appear to be the most promising of all the pumps for liquid oxygen, the hybrid Tesla/centrifugal pumps have advantages at high flow rates, and vane pumps appear useful for liquid hydrogen at some pressures and flow



rates. The efficiencies of pitot pumps make them useful at high flow rates but they require too many stages.

Three basic types of drives have been considered for these pumps; gas turbines, positive-displacement drives, and electric motors. Axial-impulse gas turbines appear well-suited for all the dynamic pumps, and positive displacement drives are suitable for positive displacement pumps. Electric motors are suitable for all the dynamic and displacement pumps if weight is not an important consideration.

Reliability and life are important considerations in the selection of the type of pump drive to be used and its design. Bearings and seals must be carefully studied and evaluated. In the design of gas turbine drives, means for cooling the turbine blades need to be examined.

### Pump Bearings

Nearly all the liquid-hydrogen pumps developed to date use rolling-element bearings for the rotating parts (Winn *et al.*, 1974). Lubrication is one of the most serious difficulties. The use of bearing retainers with good lubricating characteristics have resulted in bearing lives of up to 20 hours or more for  $DN^*$  values of 1.8 million but bearings that can operate at high speeds for relatively long periods of time are required. The new generation of pumps are being designed to operate at speeds above the limits of current experience ( $DN = 2.4$  million).

New innovative concepts are needed. One of the alternatives to ball bearings that has been under study is a fluid-film bearing that uses the cryogenic liquid being pumped as the lubricant, and operates either in the hydrostatic or hydrodynamic mode. The major problem that has been encountered with this type of bearing is the wear from the high-speed rub that occurs during lift-off and shutdown, and during rotor excursions caused by sudden shock and instability.

In order to reduce the wear, and also the fatigue, in rolling-element and journal bearings under cryogenic conditions, studies and tests have been carried out on hybrid combinations of ball and hydrostatic journal bearings.

### Pump Seals

Considerable progress has been made on the development of pump seals that work effectively at extreme temperatures and speeds (Burcham and Roynton, 1977) but there is still an inadequate technology base for the design of small seals.

The relatively low-flow high-head turbopumps being studied for staged-combustion-cycle engines call for seals that are outside the state of the art in several respects. They must not only be smaller than any developed so far, but must function effectively for 300 runs with 10 hours between overhauls, something that has not been required

\*  $DN$  is a parameter of bearing performance.  $D$  is the shaft diameter in millimeters and  $N$  is the shaft speed in rpm.

before. Preliminary designs of an oxygen turbopump indicate it will be necessary to operate at shaft speeds of up to 90,000 rpm to realize reasonable pump and turbine efficiencies and keep the weight of the unit down. The shaft diameter for this turbopump would be approximately 20 mm, resulting in a rubbing velocity at the periphery of the seal of 183 m/sec at 90,000 rpm. This rubbing velocity is outside the technology base for conventional rubbing-contact seals.

Hydrostatic and hydrodynamic fluid-film seals should make it possible to achieve the multiple starts and extended life required, since fluid films essentially eliminate rubbing contact while keeping the leakage rate down to an acceptable level. Burcham and Roynton have described the design and analysis of two alternative primary-seal configurations (the spiral-groove seal and the Rayleigh step piston-ring seal) and have reported the experimental evaluation of these seals with gaseous nitrogen and liquid oxygen. Both configurations appear to work satisfactorily, as does a secondary piston-ring seal they describe.

### Combustion

The main emphasis in this area is on (a) the combustion of hydrocarbon fuels in rocket motors and preburners, (b) ways of preventing deposits in the cooling passages of combustors that are cooled by heavy hydrocarbon fuels, (c) combustion stability, (d) throttling, and (e) the ignition of low-thrust combustors.

#### Combustion of Hydrocarbon Fuels

Tests have been carried out to (a) determine if and how hydrocarbon fuels can be burned stably under conditions that will yield high performance, (b) assess the adequacy of a vaporization model for the prediction of performance, and (c) study the effect of combustion design variables on performance (Aerojet, 1979a; Pavli, 1979).

Pavli ran tests with three different fuels (RP-1, JP-10, and liquefied natural gas) and liquid oxygen at a combustion chamber pressure of 600 psia, varying the LO<sub>2</sub>/fuel ratio, the length of the combustion chamber (8.5-22 inches), and the injector design. The tests were made with four types of injectors, each of which was reamed several times to vary the pressure drop. The results showed that (a) heavy hydrocarbons can be burned stably in state-of-the-art combustion system designs, (b) the vaporization model is adequate for the evaluation of density and viscosity effects on performance, and (c) for the higher-density hydrocarbon fuels, the vaporization model is also useful for showing the effect design variables (e.g., combustor length and injector pressure drop) can have on performance.

Current research is focused on combustion stability, throttling and ignition of low-thrust combustors.

#### Deposits in Cooling Passages

If a liquid hydrocarbon fuel is used to cool a combustor wall before it is injected into the chamber and burned, deposits may collect on the hot side of the cooling passages as a result of fractionating

and coking. Such deposits would interfere with the cooling of the wall and might result in a weakening and failure of the metal.

Studies are now being initiated to determine the conditions under which such deposits can form and how they might be avoided.

### Heat Transfer

All of the work in this area is focused on problems associated with the cooling of combustion chambers.

### Life of Reusable Combustors

To reduce the size and weight of rocket motors, operating pressures must be increased, but high chamber pressures impose severe cooling requirements, particularly at the nozzle throat. To meet the minimum life requirements for the reusable high-performance rockets that are being designed for the decades ahead, the combustor walls are being fabricated with relatively high-strength high-conductivity copper-base alloys.

Improvements in operating life have been achieved by coating the inner surfaces of combustion chambers with thermal barriers (Quentmeyer et al., 1978), some of which are described below. Improvements in combustor life have also been obtained by reducing the stiffness of the outer wall on the theory that failures are due to low-cycle thermal fatigue, although subsequent experimental work has led to the conclusion that failures are due to progressive cycle-by-cycle deformation, or "ratcheting" (Hannum et al., 1979).

### Regenerative Cooling Techniques

A parametric study has been carried out that defines the regenerative\* cooling required to give two types of motors (the LO<sub>2</sub>/LH<sub>2</sub> gas generator type and staged-combustion type) a life of 250 missions over a 20,000-600,000-lb thrust range (Cook, 1979). Maximum chamber pressures were determined for three hydrocarbon propellants (RP-1, methane, and propane) with various types of cooling: (a) regenerative cooling alone and (b) regenerative cooling in conjunction with the use of thermal barriers on the combustion chamber walls (carbon layers, ceramic coatings, and graphite liners), (c) other types of cooling (film\*\* cooling and transpiration\*\*\* cooling), innovative combustion techniques (zoned combustion\*\*\*\*), or (d) combinations of these.

\* Cooling of the combustion chamber wall by passing one of the propellants through the cooling jacket or cooling tubes prior to its injection into the chamber.

\*\* Introduction of a relatively small amount of a propellant through holes in the combustion chamber wall upstream of the area to be cooled such that it flows over the surface in a thin film.

The study showed that the LO<sub>2</sub>/methane propellant combination enabled the highest chamber pressures. For the LO<sub>2</sub>/RP-1 combination to be competitive, it was necessary to use a carbon layer and a liquid-gas injection design because of the low decomposition temperature of RP-1.

Combinations were found to give the best results; combinations of carbon layers and ceramic coatings for LO<sub>2</sub>/RP-1 combustors and combinations of ceramic coatings and film cooling for LO<sub>2</sub>/methane and LO<sub>2</sub>/propane.

### Transpiration Cooling Techniques

Transpiration techniques (Aerojet, 1979b) make it possible to cool critical regions of a combustion chamber effectively but a broader technology base needs to be developed. There are problems with (a) fabrication, (b) the achievement of the low flow rates required, and (c) the achievement of flow distributions that will give uniform wall temperatures.

Gains are being made, however. New electroforming, photo-etching, diffusion bonding, and electron-beam welding techniques are enabling fabrication of the components required. Materials with more uniform porosity (e.g., "discrete porous media") are now available and improved analytical models for such materials have been developed.

It is essential that the amount of propellant used for transpiration cooling be a minimum since it degrades the performance of a motor. One way of accomplishing this is by using transpiration cooling only in the regions where it is necessary and using regenerative cooling elsewhere. Aerojet (1979b) designed an experimental LO<sub>2</sub>/LH<sub>2</sub> motor that was cooled this way, using photo-etched copper plates for the transpiration cooling and hydrogen as the coolant. Tests on this motor provided information that can be used for the future design of reusable high-pressure (3,000-5,000 psi) rocket motors.

### Nozzle Aerodynamics

Full advantage has not been taken of unconventional nozzle designs and their potential for improvements in the performance, life, and design of liquid-propelled rockets. For example, the use of a cluster of combustors around a contoured plug instead of one large combustor would make it possible to increase the expansion ratio of a nozzle for a given nozzle length or, conversely, shorten the nozzle length for a given expansion ratio. The first option (a higher expansion ratio), an example of which is seen in Figure 13 would improve the performance

\*\*\* Introduction of a relatively small amount of the propellant through a porous section built into the chamber at or slightly upstream of the area that needs to be cooled.

\*\*\*\*The introduction of an excessive proportion of one of the propellants (usually the oxidizer) through injector holes near the chamber wall, resulting in lower combustion temperatures in this region.

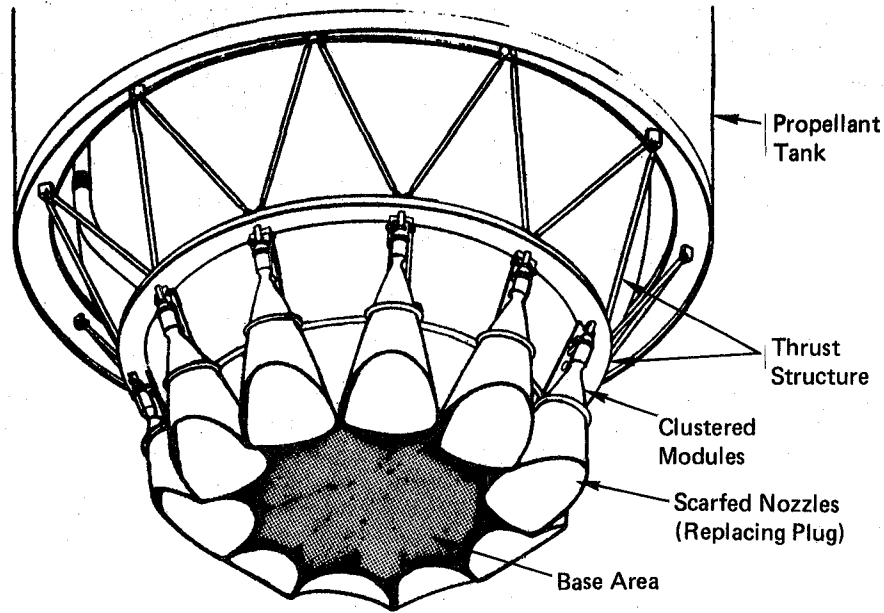

SOURCE: NASA

FIGURE 13 Plug Cluster Engine Concept

for a given chamber pressure or make it possible to increase the performance by going to higher chamber pressures. There are trade-offs, of course. Higher pressures cause more severe heat transfer problems and affect the life of a motor and clustering adds to performance and weight problems (Aerojet, 1979c) but a plug cluster engine could be competitive with an uprated RL-10 or the advanced high-performance motor discussed earlier in this report.

Other unconventional nozzles (e.g., the dual-throat and dual-expander nozzles shown in Figure 14) also need to be evaluated and considered for use where they have particular advantages.

#### Low-Gravity Cryogenic Fluid Management

The storage and handling of cryogenic propellants under the virtually weightless (low-acceleration) conditions that occur in some missions poses some difficulties. The in-orbit refueling of future space vehicles is one of the problems that has been given some attention (Cady and Miyashiro, 1978; Merion *et al.*, 1978; Merino *et al.*, 1980).

The most important of the storage and handling problems are (a) the positioning of the cryogenic liquids in the tanks during low-acceleration firing and refueling, (b) the transfer from supply to receiving tanks during low-acceleration flight, (c) long-term storage, and (d) flow instabilities in the piping between the tanks and the combustion chamber during starts.

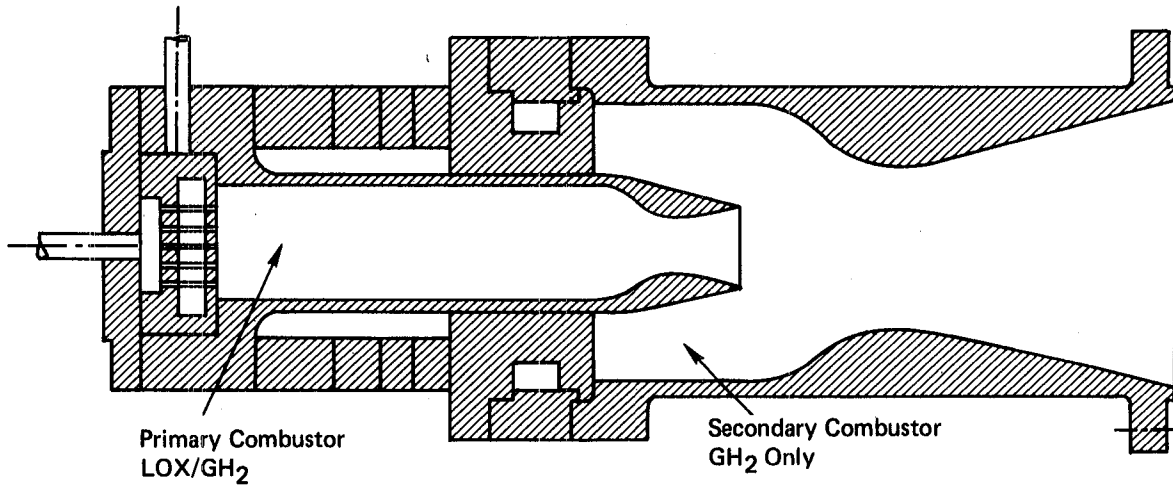

Dual Throat Combustor

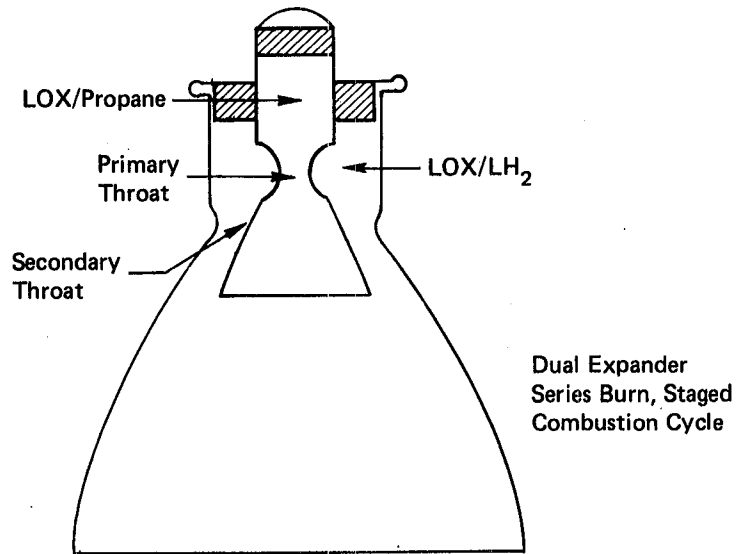

SOURCE: NASA

FIGURE 14 Dual Throat and Dual Expander Designs

To fill a tank with a liquid, there must be a continuous liquid-vapor interface (no vapor bubbles or pockets) and the liquid must not interfere with the venting of the vapor. The liquid can be settled and positioned, as required, by low-level accelerations that are either sustained or intermittent. During the firing of the rocket engine(s), the tank contents must be positioned so that there is always liquid over the outlet.

Long-term cryogenic storage requirements for future missions indicate the need for more heat transfer research, more information on reusable insulation performance, and the development of design criteria for light-weight low-cost Dewar shells.

To reduce flow instabilities in transfer lines, it is also necessary to know more about the thermodynamics, heat transfer, and fluid dynamics of transient two-phase flow. Some work has already been done in this area (Cady, 1973).

To obtain the information described above, an in-space experimental program has been proposed (NASA, 1979; Bradshaw and King, 1977).

#### Component and System Life, Reliability, and Maintenance

The committee examined three categories of interest in this area:

- (a) combustor wall failures
- (b) combustor life prediction techniques, and
- (c) non-destructive evaluation tools

#### Combustor Wall Failures

To determine the effect of the wall temperature on the life of a combustor and to obtain a better understanding of the failure mechanism, NASA ran tests on 21 cylindrical sections (three different materials), cycling them to failure (Quentmeyer, 1977). All of the failures were characterized by a thinning of the cooling channel wall and, finally, tensile rupture.

The cycles-to-failure data correlated with the surface temperature of the wall and the temperature difference across the wall but the results obtained did not agree with the results obtained from uniaxial isothermal tests.

Preliminary analytical studies (Kasper and Notardenato, 1979) have indicated that thin copper closeouts with low-stiffness overwraps (See Figure 15) can improve the cyclic life of regeneratively cooled milled-channel combustors, since they would constrict the thermal expansion of the liner to a lesser extent during the firing cycle. This was confirmed by tests on three combustors.

#### Combustor Life Prediction Techniques

NASA has developed a simple technique for estimating the life of a regeneratively cooled combustor (Kasper, 1977). Making use of the combustion gas temperature and the temperature difference between the hot surface of the wall and outside surface of the closeout, the technique enables a quick estimate of the effect that design changes or test-cycle variations will have on combustor life. The paper by Kasper

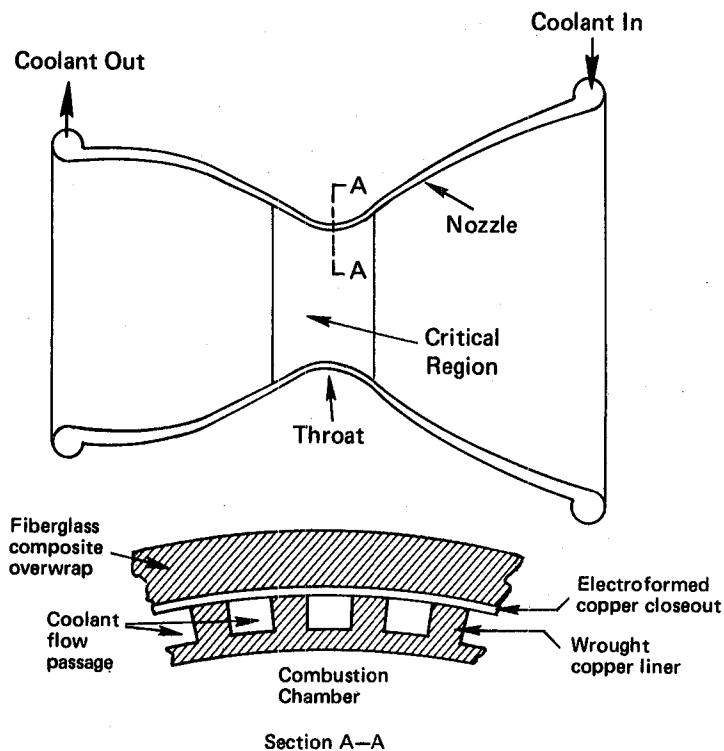

SOURCE: NASA

FIGURE 15 Regeneratively Cooled Low-Stiffness Thrust Chamber Closeout

graphically presents the strain range and life expectancy for a typical high-performance combustor with a half-hard zirconium-copper liner and an electroformed nickel closeout.

Although life predictions for regeneratively cooled combustors are normally derived from classical fatigue principles, the failures observed in experimental tests do not appear to be due entirely to fatigue. Instead, the bulging and thinning of the wall progresses with each firing until it finally fails.

A preliminary analysis of a cylindrical oxygen-free high-conductivity copper combustor by Vos and Armstrong (1977) has shown that the thinning of the combustor wall can be predicted by taking into account the cumulative plastic effects. Subsequent work by Armstrong (1979) includes the effect of the properties of the material in the analysis.

A study has also been made of the thermomechanical behavior and fatigue life of various plug-nozzle configurations (Armstrong and Brogren, 1975).



## Non-Destructive Evaluation Tools

NASA has developed an eddy-current probe technique for determining the remaining life expectancy of a motor (Johnson, 1978) that is now being evaluated.

### Assessment of NASA's Fundamental Technology Program

NASA's approach to providing solutions to fundamental problems is not adequate. The present approach is what one might expect for an advanced design and development program, appropriate for the solution of specific immediate problems but not for a better understanding of the complex phenomena involved and an enlargement of the body of fundamental knowledge. What is needed is a more basic conceptual approach that can lead to new and innovative solutions of future, as well as current, problems.

The general procedure at the present time is for NASA to give contracts that cover specific problems to one or two aerospace firms (usually engine developers) who usually try to find solutions by extrapolating designs or analyses that have resulted from the solution of previous problems. The solutions are often limited by the materials and configurations used in the past, or lead to rather complicated designs that are difficult and costly to fabricate. The contracts usually result in hardware rather than generalized concepts that enlarge the fundamental technology base. The end-result is less than adequate for this nation's long-range goals.

A new approach is needed. As is evident from the bibliography and the citations in this report, the bulk of the work in liquid rocket propulsion has been done by the rocket engine companies or other aerospace companies. Instead of contracting its fundamental technology work to the aerospace industry, NASA should expand the fundamental research being done at its Lewis Research Center and, in addition, involve a broader community of engineers and scientists in its program. Workshops and seminars should be held to identify the problems and needs of the space program, with encouragement and support for directed research given to those whose ideas and knowledge appear useful.

## LIQUID ROCKET PROPULSION FOR DOD PROGRAMS

Military interest in large and medium-sized liquid rocket motors is now limited to their use for the launching of satellites for communication, navigation, reconnaissance, surveillance, and other purposes and, possibly, their use in the "advanced military vehicle" described below. Liquid rocket motors are no longer being produced for the launching of missiles because it is much easier to handle, store, and utilize solid propellants. These advantages make solid propellants the better choice for missiles that must be ready for immediate use, but not the better choice for the launching of satellites where payload/weight ratios are more important than a readiness capability.

Although solid propellants are now the main source of propulsion for missiles, small liquid thrusters are still used for maneuvering and guidance where it is necessary to have a start-stop capability and, if need be, vary the thrust. The propellants used for such thrusters are usually non-cryogenic liquids, either  $N_2O_4$ /monomethylhydrazine or the monopropellant hydrazine.

The committee was not charged with the task of studying and evaluating the liquid rocket activities of the armed services but considered it necessary to review the scope and general content of the DOD program to understand how they relate to and depend upon the activities of NASA.

### Military Mission Model

As indicated in the MISSION MODEL section of this report, DOD\* will use the Space Shuttle and its derivatives as the primary vehicle for earth-to-orbit satellite launchings during the foreseeable future. Until the Space Shuttle becomes fully operational, the Air Force will continue to use its Atlas-based and Titan-based vehicles and, as of July 1980, had 45 such launchings planned for the 1981-85 period.

---

\*The Air Force has the responsibility for the military space program.

## Launch Vehicles for Military Space Missions

As of now, DOD is relying on NASA for the development and upgrading of the Space Shuttle. DOD is interested in follow-on development of motors for intermediate and heavy-lift launch vehicles. The department has no program of its own for the development of large liquid-fueled rocket motors. DOD is anticipating working with NASA for the development of high-thrust and low-thrust orbital transfer vehicles.

DOD is interested in the single-stage-to-orbit (SSTO) vehicle concept NASA is studying but for a different set of reasons. While NASA is interested in a more-or-less completely reusable vehicle with low fabrication and operating costs, DOD is interested in having a horizontal take-off vehicle that can be kept on alert for emergencies and specific military tasks, fully loaded with cryogenic propellants. For DOD, readiness and short turnaround times are the most important considerations, with the optimization of cost and payload secondary.

During the past few years, the Air Force has carried out a number of studies on SSTO components for what it calls an "Advance Military Vehicle." Studies have been made of (a) ways of upgrading the Space Shuttle main engine for this task, (b) ways of increasing combustion efficiencies, (c) nozzle configurations, (d) high temperature turbines for turbopumps and (e) tank designs. During the next few years, it is planned to undertake studies of (a) alternate engine concepts, (b) pump bearings and seals, (c) light weight engine components, (d) feed systems, (e) ways of storing cryogenic propellants for long periods of time and to seek funding for component development and demonstration programs.

DOD and NASA coordinate their activities through the Joint Army, Navy, NASA, Air Force Interagency Propulsion Committee (JANNAF).

## INDUSTRY CAPABILITY

Figures 16 and 17 tell the story of industrial activity in liquid rocket propulsion in the United States. Referring to Figure 16, the activity began in the 1940s with a relatively low research and technology development effort sponsored by government agencies, increased gradually into the early 1950s, and then, in the mid 1950s, increased rapidly as development work was initiated on missiles for the armed forces. By 1964, funding for liquid rocket propulsion was up to \$1,700 million per year and the aerospace industry was thriving. As illustrated in Figure 17, work on the Atlas, Thor, and Jupiter missiles

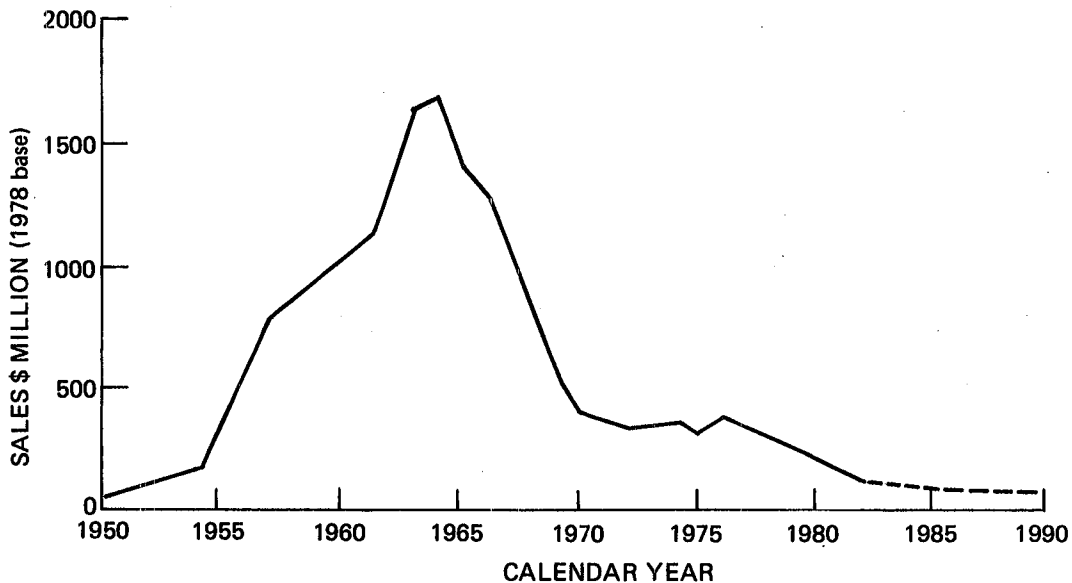

SOURCE: NASA

FIGURE 16 Liquid Rocket Propulsion Sales History

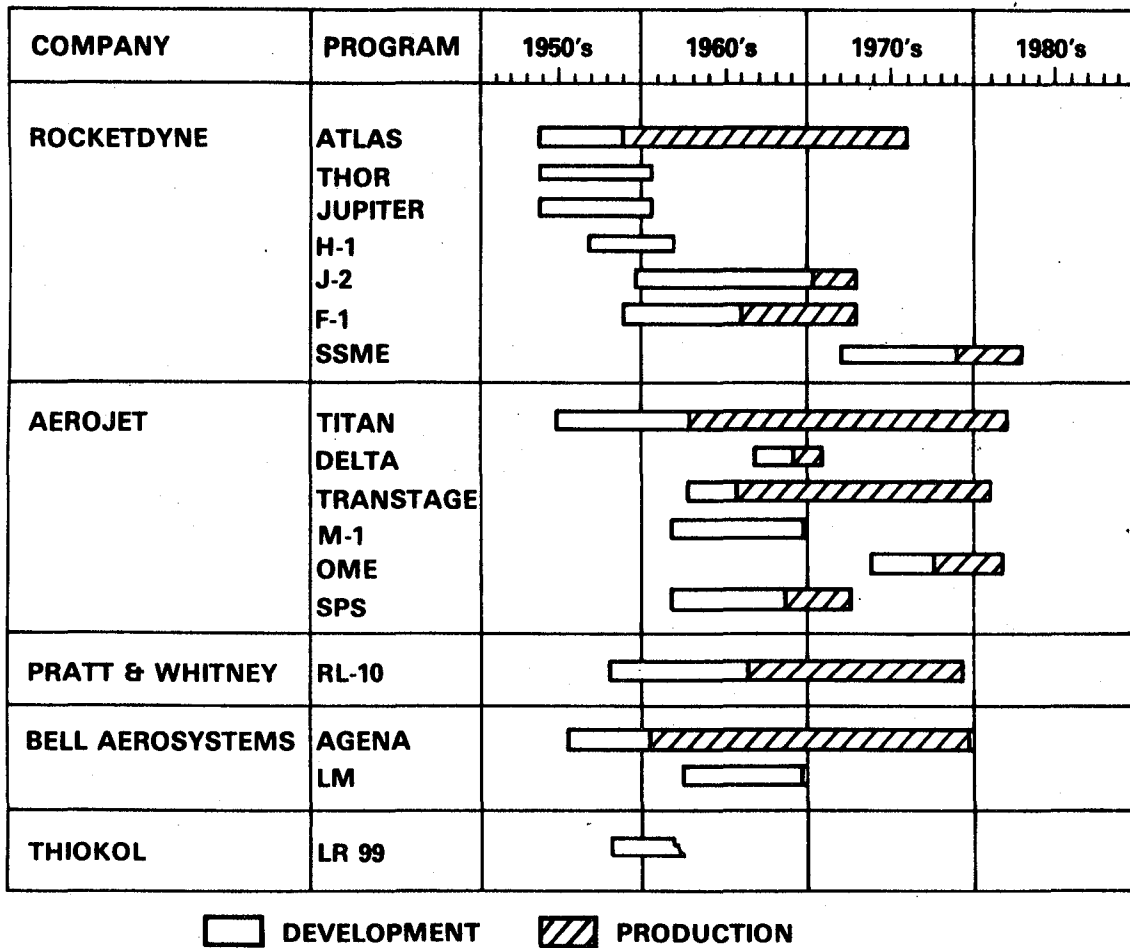

SOURCE: NASA

FIGURE 17 Development and Production History of Liquid Rockets

began in 1954. The Titan program started the following year, and the development of the Agena rocket was underway a year later. Before the decade was out, a start had also been made on the H-1, J-2, and F-1, the large liquid rocket motors that were to lead to the development of the Saturn vehicles for the manned Apollo moon shots.

The turning point came when DOD began to shift its interest from liquid to solid-fuel rockets. Solid propellants eliminated the problems associated with the long-term storage of cryogenic liquid propellants in missiles that had to be ready for launch at a moment's notice and also simplified the operation and maintenance of a strategic and tactical missile force. The performance characteristics of solid rocket motors were not as good as those of liquid rocket motors, requiring the use of heavier vehicles, but the solid-propelled missiles were, on balance, the best choice for the task. Liquid-fueled rockets continued to be used for the launching of satellites (both civil and military), the Apollo program, and planetary spacecraft but they represented a lesser part of the total expenditure. As the Atlas and Titan

missile programs were phased down, the liquid rocket sector of the aerospace industry began to decline and dropped off rapidly as the Apollo program came to an end and budget cuts reduced the size of the civil space effort. By 1970, the aerospace industry's level of activity in liquid rocket propulsion was down to \$400 million per year and by 1980 it was little more than it was when it all began in 1954, less than \$250 million per year. Work on large engines came to a virtual halt, except for the Space Shuttle main engine (SSME) and some production of the Titan, Transtage, Agena and RL-10.

During the 1970-79 period, the specialized personnel involved in engineering, management, procurement, manufacturing, test, and quality control in the liquid propulsion sector of the aerospace industry dropped from 8,600 to less than half that number.\*

The low level of Titan production will come to an end in 1983 although a few may be produced for the launching of DOD satellites until the Space Shuttle becomes fully operational. Aerojet will be out of the large liquid rocket business when Titan production ends. At that point, Rocketdyne, with its responsibility for the SSME and its uprated versions, will be the only company left with an organization and facilities for the development and production of large liquid rocket engines.

If NASA and DOD programs continue on their present course, Rocketdyne will also be the only company left with the capability of developing and producing medium-thrust liquid rocket motors that can be used in upper-stage vehicles. With the production of the Agena rocket at an end, Bell Aerospace is no longer active in this area. Production of the RL-10 is scheduled to end and Pratt & Whitney, with no other contracts for work on motors of this type and size, will be out of field in 1981.\*\* Aerojet will end its activity in this area in 1983.

The major aerospace companies have indicated it will take contracts totaling \$10-20 million per year to keep intact the basic 200-person (critical mass) organization required to maintain an adequate level of competence in the large and medium liquid rocket propulsion field.\*\*\* The funding NASA is now seeking for R&T on liquid rocket propulsion systems during the next decade would support the liquid rocket development capabilities of one company for a period of about seven years,

---

\* Paper presented at April 29-30, 1980 meeting by representative of U.S. Air Force Rocket Propulsion Laboratory, on file at the Aeronautics and Space Engineering Board of the National Research Council, Washington, D.C.

\*\* Subsequent to this review, on Jan. 15, 1981, NASA announced its intention to terminate its support of the 3-stage inertial upper stage (IUS-3) for the Shuttle to launch the Galileo orbiter and probe missions to Jupiter and to use a modified Centaur vehicle with its RL-10 engine instead, thus creating a need for some continued RL-10 production.

\*\*\* Unpublished survey by NASA.

since 30 percent or so of this funding would be used for work carried out in NASA laboratories. The capabilities of the one company would be maintained in R&D, but an engineering and production capability would not be maintained.

The committee views with concern the loss of development capability over the next few years as most of the major aerospace companies phase out their work on large and medium-sized liquid rocket motors. The team of skilled and experienced scientists, engineers, and technicians that have been brought together over the years, once dismantled and dispersed, cannot be reassembled. While the committee views with concern a potential loss of competitive industrial capability in large liquid booster rocket engines, it should be clearly understood that it does not propose or recommend the artificial maintenance of a contractor's capability in the absence of a real need for his product. For funding gaps longer than a few months, support of this kind is very unlikely to retain a competent capability or otherwise prove worthwhile. Further, the committee holds that support of a competing contractor through Research and Technology funding alone is impractical, partly because of the magnitude of the funding required and partly because R&T funding will not retain first quality engineering and production facilities and personnel of the kind needed actually to be "competitive."

The recommendations of the committee affecting industrial survival, therefore, are limited to: (1) activities and funding which will support immediate commencement of work to upgrade the RL-10 and adapt it as an orbital transfer vehicle (see section on ORBITAL TRANSFER VEHICLES); and (2) technology development work making it possible to uprate the earth-to-orbit shuttle (see section on EARTH-TO-ORBIT VEHICLES).

Implementation of the program recommended in this report can productively sustain two contractors in the liquid-fueled rocket field, although their capability will not be directly competitive in very large boosters.

## BIBLIOGRAPHY

- Aerojet. 1979a. Fuel/Oxydizer-Rich High-Pressure Preburners, Task 1 Review, Preburner Analysis and Conceptual Design (unpublished).
- Aerojet. 1979b. Performance of a Transpiration-Regenerative-Cooled Rocket Thrust Chamber. College Park, MD.: U.S. National Aeronautics and Space Administration (CR-159742).
- Aerojet. 1979c. Unconventional Nozzle Tradeoff Study. College Park, MD.: U.S. National Aeronautics and Space Administration (CR-159520).
- Aerojet. 1980. Low-Thrust Chemical Rocket Propulsion System Pump Technology, Task 1 Review. Sacramento, CA.: Aerojet Liquid Rocket Co.
- Armstrong, W.H. 1979. Structural Analysis of Cylindrical Thrust Chambers, Final Report, Vol. 1. Lockheed Missiles and Space Co. College Park, MD.: U.S. National Aeronautics and Space Administration (CR-159522).
- Armstrong, W.H. and E.W. Brogren. 1975. Thrust Chamber Life Prediction, Vol. 2, Plug Nozzle Centerbody and Cylinder Life Analysis. Boeing Aerospace Co. College Park, MD.: U.S. National Aeronautics and Space Administration (CR-134822).
- Bradshaw, R.D. and C.D. King. 1977. Conceptual Design for Spacelab Two-Phase Flow Experiments. Convair Division, General Dynamics. College Park, MD.: U.S. Aeronautics and Space Administration (CR-135327).
- Burcham, R.E. and J.L. Roynton. 1977. Small High-Speed Self-Acting Shaft Seals for Liquid Rocket Engines. Rocketdyne. College Park, MD.: U.S. National Aeronautics and Space Administration (CR-135167).
- Cady, E.C. 1973. Study of Thermodynamic Vent and Screen Baffle Integration for Orbital Storage and Transfer of Liquid Hydrogen. McDonnell-Douglas Astronautics Co. College Park, MD.: U.S. National Aeronautics and Space Administration (CR-134482).



- Cady, E.C. and H.H. Miyashiro. 1978. Filling of Orbital Fluid Management Systems. McDonnell-Douglas Astronautics Co. College Park, MD.: U.S. National Aeronautics and Space Administration (CR-149405).
- Cook, R.T. 1979. Advanced Cooling Techniques for High-Pressure Hydrocarbon-Fueled Engines. Rocketdyne. College Park, MD.: U.S. National Aeronautics and Space Administration (CR-149790).
- Hannum, N.P., R.J. Quentmeyer, and H.J. Kasper. 1979. Some Effects of Cyclic-Induced Deformation in Rocket Thrust Chambers. College Park, MD.: U.S. National Aeronautics and Space Administration (TM-79112).
- Johnson, D.P. 1978. Report on Eddy-Current Measurement System for Flat Plates (unpublished).
- Kasper, H.J. 1977. Graphical Method for Predicting Life of a Rocket Thrust Chamber with Half-Hard Zirconium-Copper Liner and Electroformed Nickel Closeout. College Park, MD.: U.S. National Aeronautics and Space Administration (TMX-3499).
- Kasper, H.J. and J.J. Notardenato. 1979. Effect of Low-Stiffness Close-out Overwrap on Rocket Thrust-Chamber Life (unpublished).
- Merino, F., M.H. Blatt, and N.C. Thies. 1978. Filling of Orbital Fluid Management Systems. Convair Division, General Dynamics. College Park, MD.: U.S. National Aeronautics and Space Administration (CR-159404).
- Merino, F., J.A. Risberg, and M. HILL. (\*). Orbital Refill of Propulsion Vehicle Tankage. Convair Division, General Dynamics. College Park, MD.: National Aeronautics and Space Administration (CR-159722).
- NASA. 1978. Expendable Launch Vehicles Program.\* Office of Space Transportation Systems, U.S. National Aeronautics and Space Administration, Washington, D.C.
- NASA. 1980a. Liquid Rocket Booster for STS.\*
- NASA. 1980b. Propulsion/Vehicle Applications.\*
- NASA. 1980c. Current Mission Model: Near Term.\*
- NASA. 1980d. A Technology Plan for Advanced Liquid Propulsion System.\* Office of Aeronautics and Space Technology, U.S. National Aeronautics and Space Administration, Washington, D.C.

\* Paper presented at April 29-30, 1980 meeting by representative of U.S. National Aeronautics and Space Administration, on file at the Aeronautics and Space Engineering Board of the National Research Council, Washington, D.C.

- NASA. 1979. In-Space Cryogenic Fluid Management Research and Technology. NASA ad hoc Planning Committee Report, presented at second meeting of CFME (Cryogenic Fluid Management Experiment) ad hoc Review Panel, Marshall Space Flight Center, Huntsville, Alabama (unpublished).
- Pavli, A.J. 1979. Design and Evaluation of High-Performance Rocket Engine Injectors for Use with Hydrocarbon Fuels. College Park, MD.: U.S. National Aeronautics and Space Administration (TM-79319).
- Quentmeyer, R.J. 1977. Experimental Fatigue Life Investigation of Cylindrical Thrust Chambers. College Park, MD.: U.S. National Aeronautics and Space Administration (TMX-73665).
- Quentmeyer, R.J., H.J. Kasper, and J.M. Kazaroff. 1978. Investigation of the Effect of Ceramic Coatings on Rocket Thrust Chamber Life. College Park, MD.: U.S. National Aeronautics and Space Administration (TM-78892).
- Rocketdyne. 1980, Low-Thrust Chemical Rocket Propulsion System Pump Technology, Task 1 Review. Canoga Park, CA.: Rocketdyne.
- Vos, R.G. and W.H. Armstrong. 1977. Structural Analysis of an OFHC Copper Cylinder Thrust Chamber. Seattle, Wash.: Boeing (D180-20708-1).
- Winn, L.W., M.W. Eusepi, and A.J. Smalley. 1974. Small High-Speed Bearing Technology for Cryogenic Turbo-Pumps. Mechanical Technology Inc. College Park, MD.: U.S. National Aeronautics and Space Administration (CR-134615).

**End of Document**