

PROGRESS OF THE LASSO EXPERIMENT

Dr. B.E.H. SERENE

European Space Agency, Toulouse, France

ABSTRACT

The LASSO (Laser Synchronisation from Stationary Orbit) experiment has been designed to demonstrate the feasibility of achieving time synchronisation between remote atomic clocks with an accuracy of one nanosecond or better by using laser techniques for the first time. The experiment uses ground-based laser stations and the SIRIO-2 geostationary satellite, to be launched by ESA towards the end of 1981.

The first part of the paper is dedicated to the qualification of the LASSO on-board equipment, with a brief description of the electrical and optical test equipment used.

The second part gives the progress of the operational organisation since the last PTTI meeting, including the provisional list of participants.

1. INTRODUCTION

Since the last PTTI meeting an important number of activities have taken place in the framework of the SIRIO-2 programme and more specifically for the LASSO experiment :

- the units of the mechanical model have been integrated and successfully tested with the complete satellite,
- a design review has been held to examine breadboard results with a view of authorising the manufacture of the qualification units,

- the units of the qualification model have been delivered to the Centre National d'Etudes Spatiales (CNES) for integration and performance evaluation at subsystem level,
- after acceptance of the principal investigators by ESA, two LASSO Experimenters and Users Team (LEUT) meetings were held in Geneva and Paris respectively,
- the LASSO Coordination Centre (LCC) was subcontracted to the Italian firm TELESPAZIO which is already in charge of the SIRIO-2 Operations Control Centre (SIOCC).

2. QUALIFICATION OF THE LASSO PAYLOAD

2.1. LASSO On-Board Equipment

The specifications and the design concept were largely presented at the last PTTI meeting (1). It is recalled that the LASSO payload consists of :

- the retro-reflectors,
- the photo-detectors for sensing ruby and neodyme laser pulses,
- the ultra-stable oscillator,
- the counter to time-tag the arrival of the pulses.

These time-tags are to be encoded in time division multiplex with satellite housekeeping before transmission to the ground.

An overall block diagram is shown in Figure 1.

2.2. LASSO Test Equipment

The test equipment has been designed and built for easy transportation and operation with a maximum of automatic test sequences. It is used at :

- subsystem level for qualification and acceptance tests,
- system level for integration and pre-launch tests,

and consists of two inter-connected parts : the electrical test equipment (ETE) and the optical test equipment (OTE).

(1) SERENE B. and ALBERTINOLI P.,
 "The LASSO Experiment on the SIRIO-2 Spacecraft", ESA Journal,
 Vol. 4, pages 59 to 72, 1980

FIGURE 1

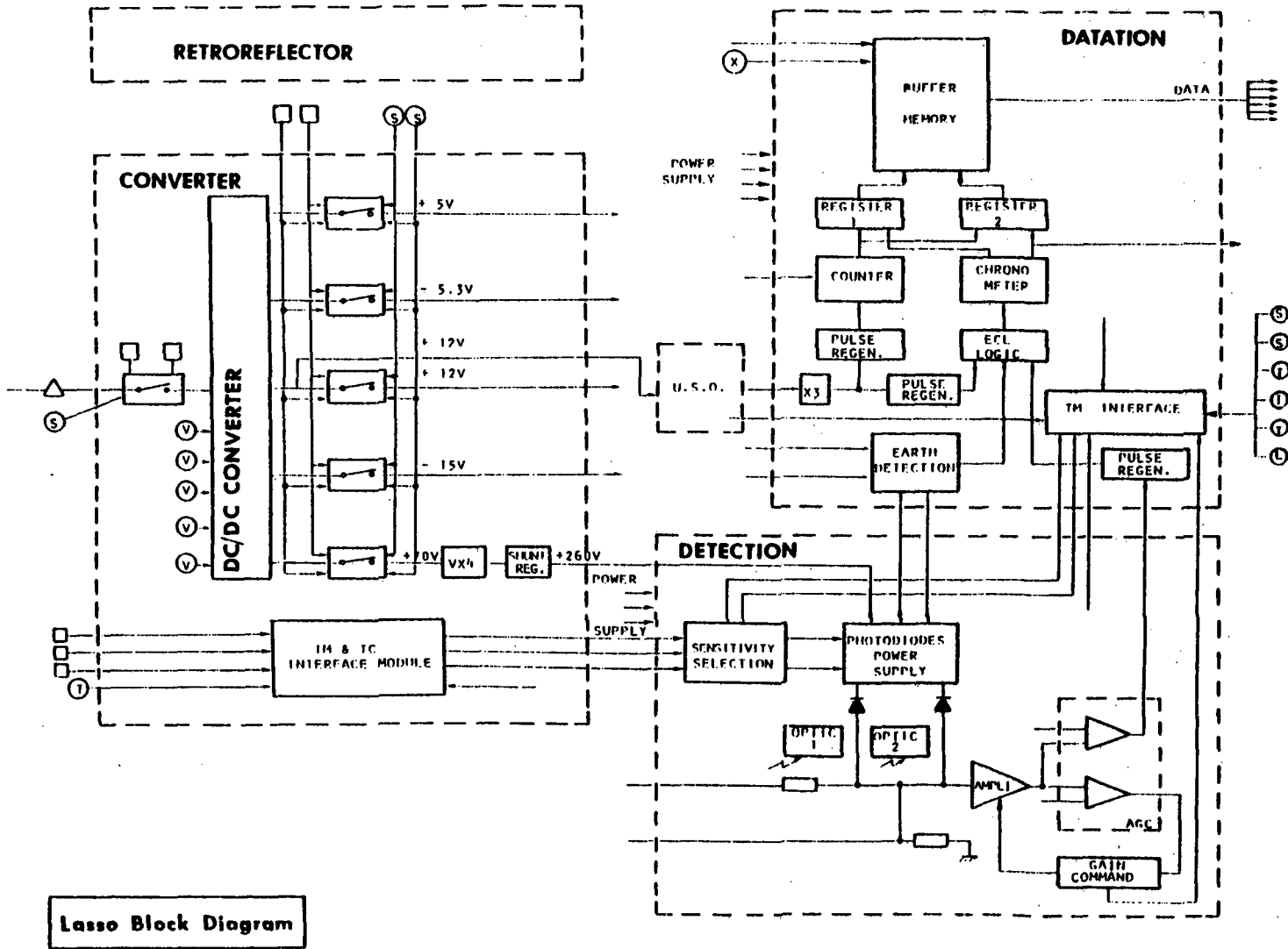

Lasso Block Diagram

2.2.1. Electrical test equipment

In order to allow a complete check of the LASSO payload, the ETE must perform the following functions :

- (a) satellite interface simulation concerning power supply, telecommand transmission, telemetry acquisition and synchronisation with satellite rotation.
- (b) laser pulse simulation by means of an electrical pulse generator which is used directly behind the photo-detectors or indirectly to trigger the OTE. In both cases, stimuli pulses are time-tagged by the ETE; these measures are used as references to verify those carried out by the LASSO equipment.
- (c) LASSO housekeeping monitoring; this function concerns temperatures, voltages, currents and status recognition.
- (d) interface with the satellite check-out equipment after integration of the LASSO payload in the satellite.

Overall control of the ETE is performed by a desk-top computer running automatic and semi-automatic test sequences and providing finally statistical treatment of the measurements performed.

An overall block diagram is shown in Figure 2.

2.2.2. Optical test equipment

The OTE, under ETE software control, sends laser pulses towards LASSO detectors and simulates the light generated by the earth albedo inside a time window corresponding to earth visibility.

The departure of the laser pulses are detected in the OTE by fast photo-diodes which provide an electrical feedback signal time-tagged by the ETE.

The block diagram of the OTE is given in Figure 3, and the main characteristics of the different parts are listed below :

LASSO SUBSYSTEM TEST CONFIGURATION

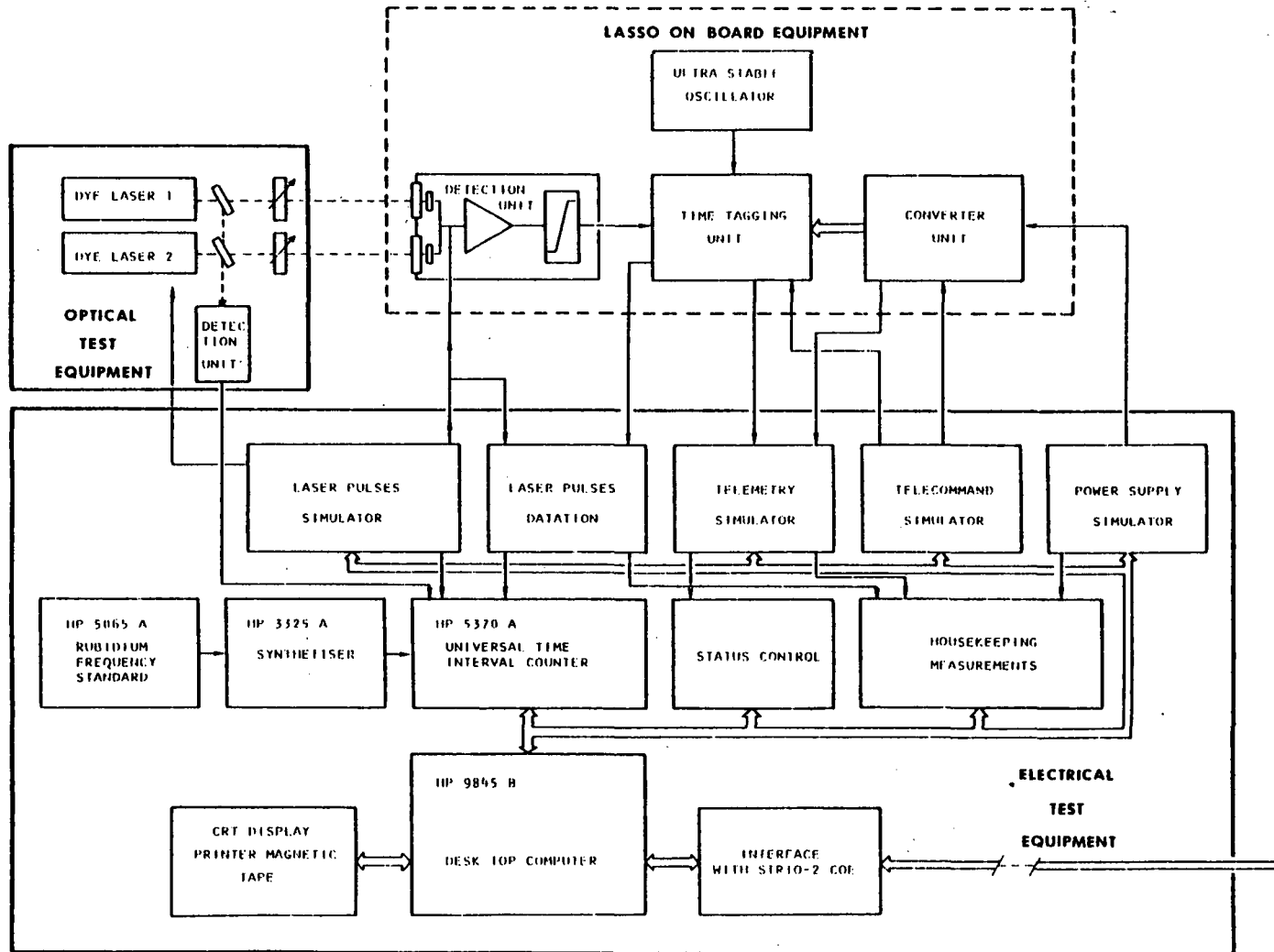
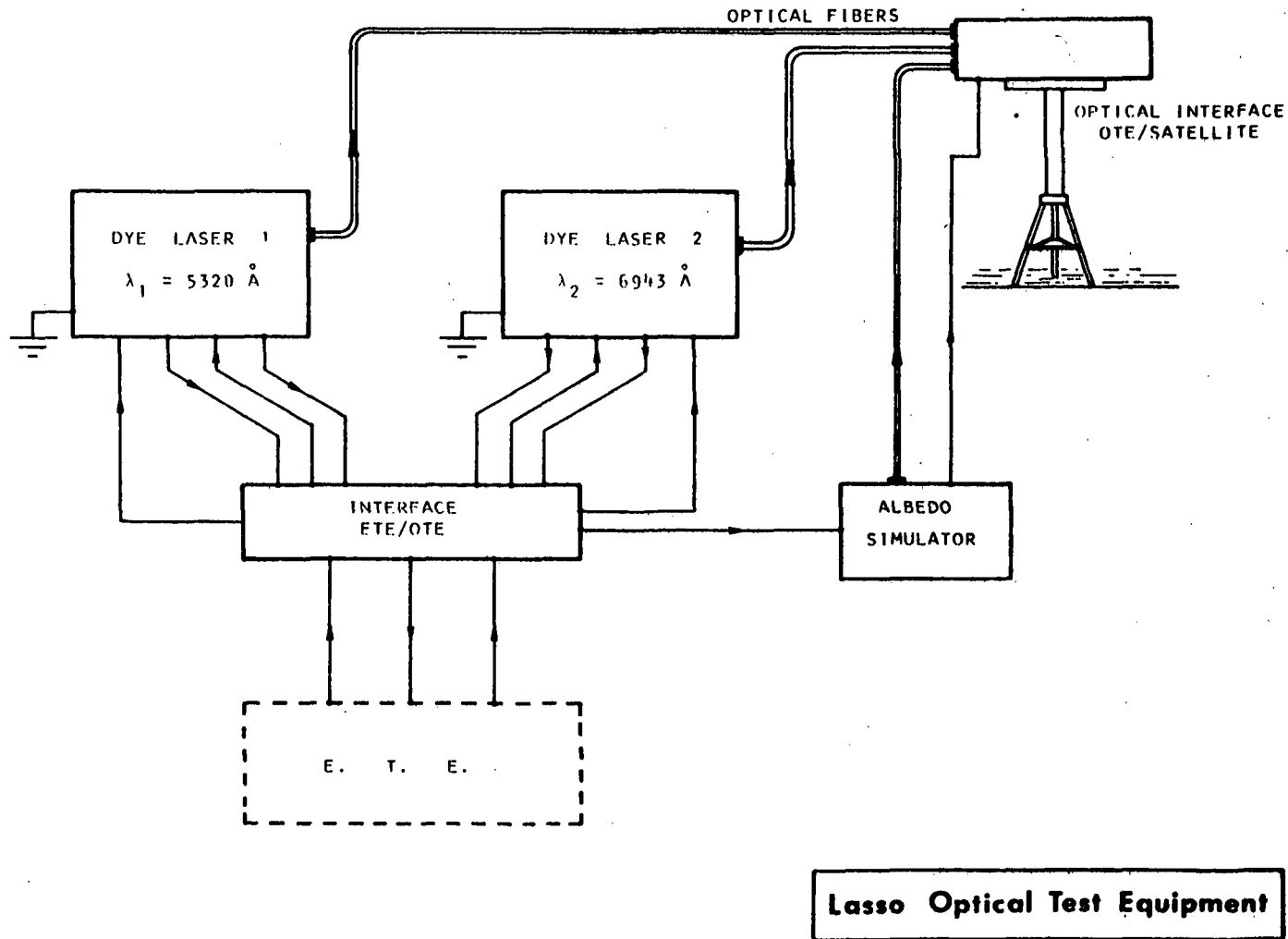

FIGURE 2

FIGURE 3



(a) dye laser for neodyme simulation

$\lambda_1 = 532.0 \text{ nm}$
 $1 < \text{PWHA}^* < 3 \text{ nsec.}$
 $0.1 < E < 30 \text{ mW/cm}^2$
maximum repetition rate : 20 Hz

(b) dye laser for ruby simulation

$\lambda_2 = 694.3 \text{ nm}$
 $1 < \text{PWHA}^* < 3 \text{ nsec.}$
 $0.05 < E < 20 \text{ mW/cm}^2$
maximum repetition rate : 13 Hz

(c) earth albedo simulator where a quartz-iodine lamp provides the illumination :

$22 \text{ } \mu\text{W/cm}^2$ for $\lambda_1 \pm 6 \text{ nm}$
 $16 \text{ } \mu\text{W/cm}^2$ for $\lambda_2 \pm 6 \text{ nm}$

(d) optical interface which collects, by means of optical fibers, the light generated by the three simulators above; after being mixed and merged into a parallel beam, the light is chopped by a mechanical shutter driven by the earth appearance signal.

(e) electrical interface between the OTE and the ETE.

* Pulse width half amplitude

2.3. LASSO Units Test

2.3.1. Retro-reflectors

The qualification programme was run by AEROSPATIALE on a test sample made of 94 dummy glass corner cubes and 4 flight-worthy quartz corner cubes. The diffraction figures of the 4 quartz corner cubes were measured before and after each test :

- vibration (sinusoidal and random)
- thermal cycle under vacuum (+50°C, -60°C)

The measured efficiency for normal incidence is in fact 20 for 694.3 nm and 17.5 for 532 nm;

2.3.2. Optics

The qualification programme on the two sets of optics was conducted by MATRA and EMD.

For the neodyme optics the results are :

- normal incidence $\lambda_c = 534.3$ nm with a bandwidth (half amplitude) of 11.8^C nm;
- 10 degrees incidence introduce a shift of the central wavelength of -2,3 nm; the bandwidth remains the same;
- the optical gain versus incidence angle was measured and the results are given in Figure 4 and 5;

For the ruby optics the results are :

- normal incidence $\lambda_c = 696.9$ nm with a bandwidth (half amplitude) of 12.1^C nm;
- 10 degrees incidence introduce a shift of the central wavelength of -2.5 nm, the bandwidth remaining the same;
- the optical gain versus incidence angle was measured and the results are given in Figures 6 and 7.

2.3.3. Ultra-Stable Oscillator (U.S.O.)

This unit, manufactured by F.E.I. (USA), was delivered fully qualified.

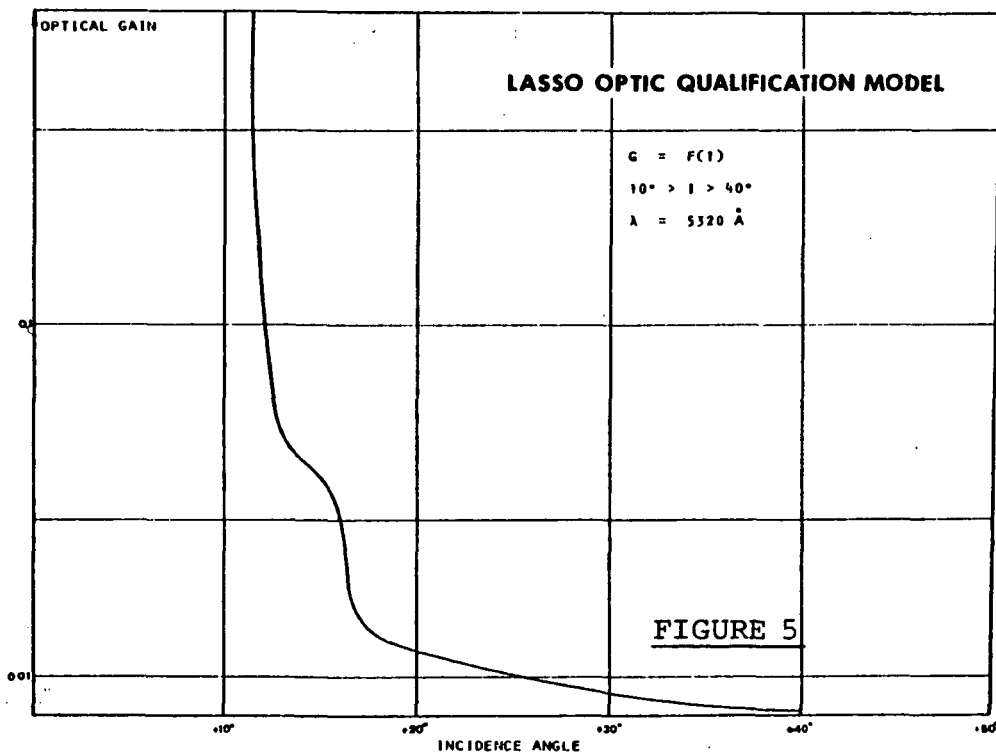
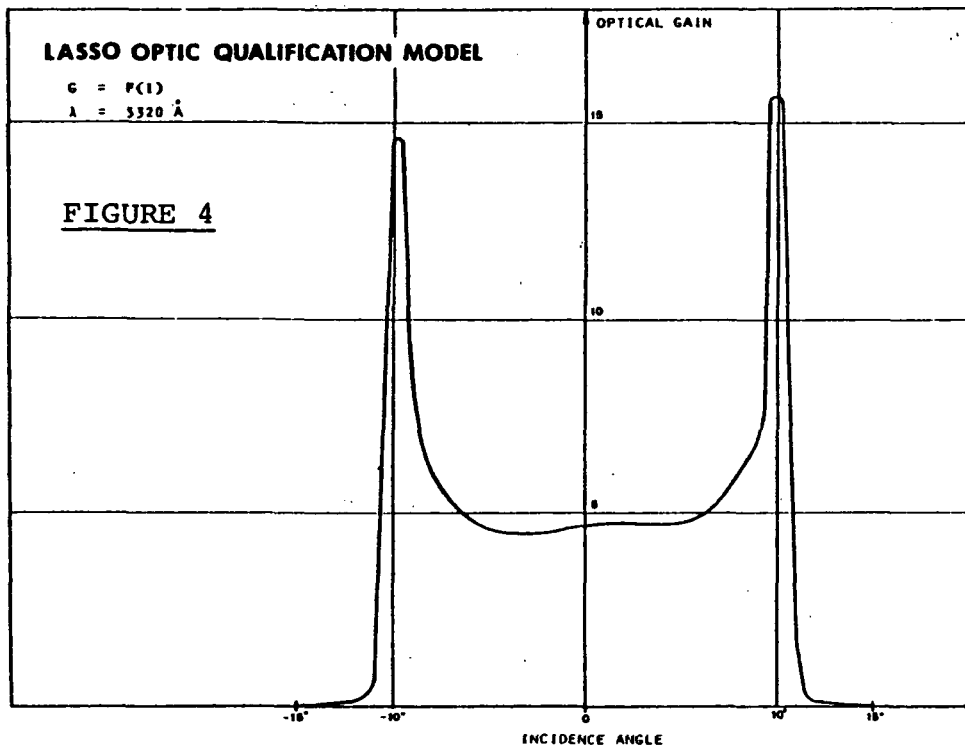

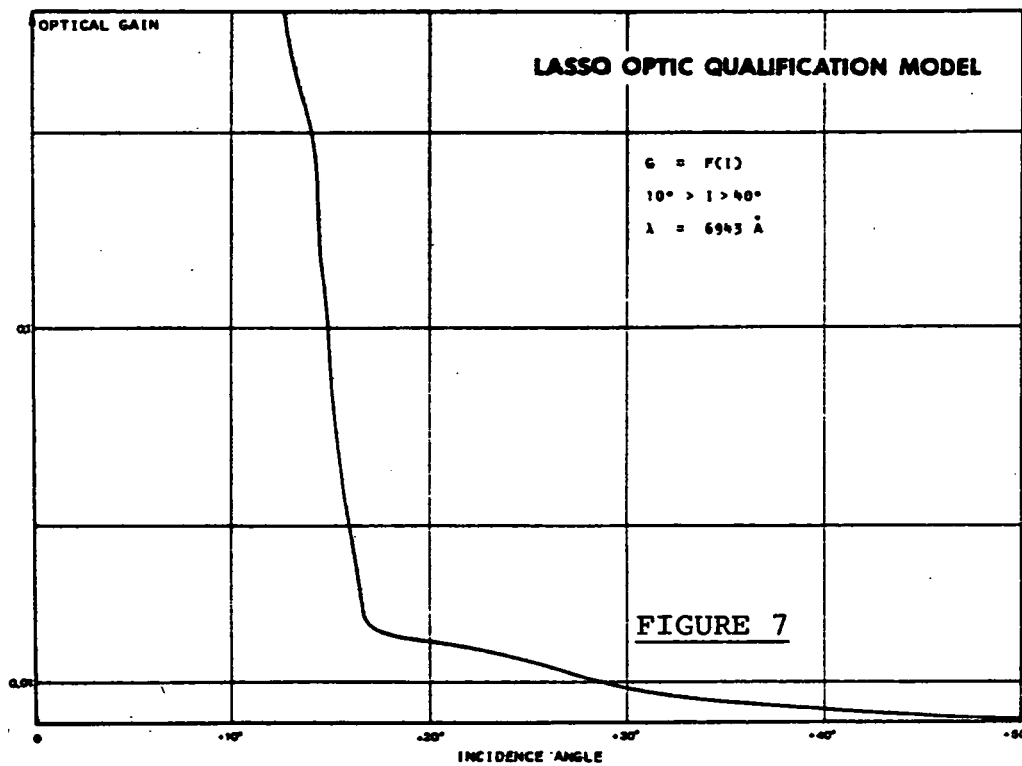
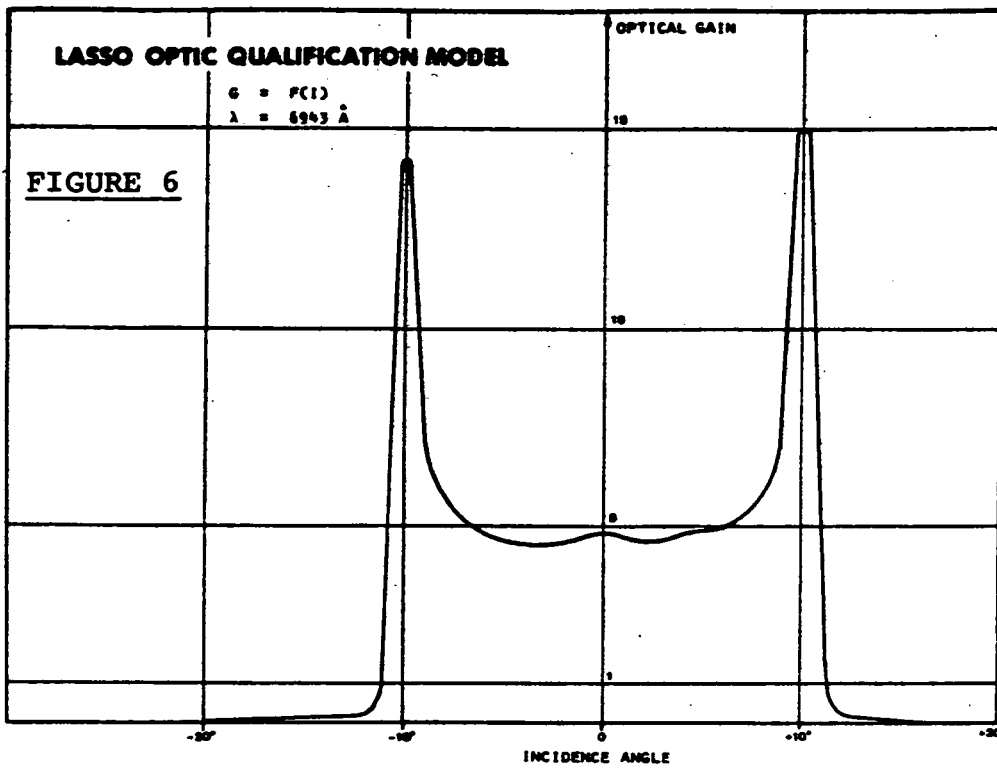

2.3.4. Converter

The qualification programme was conducted by LABEN and the following test sequence was applied :

- electrical performance,
- vibration (sinusoidal and random),
- electrical performance,
- thermal cycles under vacuum (+60°C, -20°C)
- final electrical performance.

2.3.5. Detection and datation

The qualification programme was conducted by EMD on both units, using only the ETE. The following test sequence was applied :

- electrical performance,
- vibration (sinusoidal and random),
- electrical performance (repeated),
- thermal cycles (+50°C, -10°C),
- electrical performance (repeated).

The electrical performance was controlled for six different configurations which are listed below :

Configu- ration	Pulse width (half amplitude) (nsec)	Time Sep- aration between 2 pulses of a same pair (msec)	Time Sep- aration between 2 pairs (msec)	Pulse amplitude (mV)	Time Sep- aration between 2 se- quences (msec)
1	2	0.284	1164	200	70
2		72.7			
3	20	0.284			
4		72.7		8 000	

A 5th configuration is used for false detection evaluation, with and without the presence of the earth albedo, during a period of five minutes.

Yet another configuration, No. 6, is used for the chronometer dead-time evaluation, i.e. time tagging pulses far apart of 200 μ sec.

The results obtained for the different configurations are summarised in the Table 1.

Confi- guration	sensitivity	albedo	Standard deviation (psec)	False detection
1	normal	no	148	-
2	"	"	377	-
3	"	"	137	-
4	"	"	456	-
1	maximal	yes	159	-
2	"	"	280	-
3	"	"	141	-
4	"	"	296	-
5	"	"	-	0
5	"	no	-	0
1	normal	yes	185	-
2	"	"	286	-
3	"	"	145	-
4	"	"	240	-
5	"	"	-	0
6	Operating properly			

TABLE 1

2.4. LASSO Subsystem Test

For this purpose a satellite mock-up was manufactured, enabling the units to be mounted in their exact position.

After delivery to CNES, the detection, the datation and the ultra-stable oscillator were integrated on the mock-up and inter-connected with the qualification model harness. This partial subsystem was submitted to thermal cycle under vacuum (+50°C, -10°C) during which the electrical performance was extensively controlled using the OTE and ETE.

The main results are :

- for 1900 pairs of pulses generated by the neodyme and the ruby laser simulators, in all the configurations, the standard deviation is 341 psec with a bias of 68 psec due to the fact that two different time references are used.
- the number of false detections is always less than one per hour.

After delivery to CNES, the converter was integrated in the partial subsystem. The test programme for the qualification of the complete subsystem is at present ongoing with the following activities :

- electrical performance,
- electromagnetic compatibility, including electrostatic test,
- thermal cycles,
- final electrical performance.

3. OPERATIONAL ORGANISATION

The overall SIRIO-2/LASSO organisation is shown in Figure 8.

The industrial consortium is led by the Compagnia Nazionale Satelliti per Telecomunicazioni (CNS) with two co-contractors, CNES and SELENIA, in charge of the LASSO and MDD payloads respectively, while for the operational activities the company TELESPAZIO has been entrusted, under ESA contract, to run the SIOCC and the LCC.

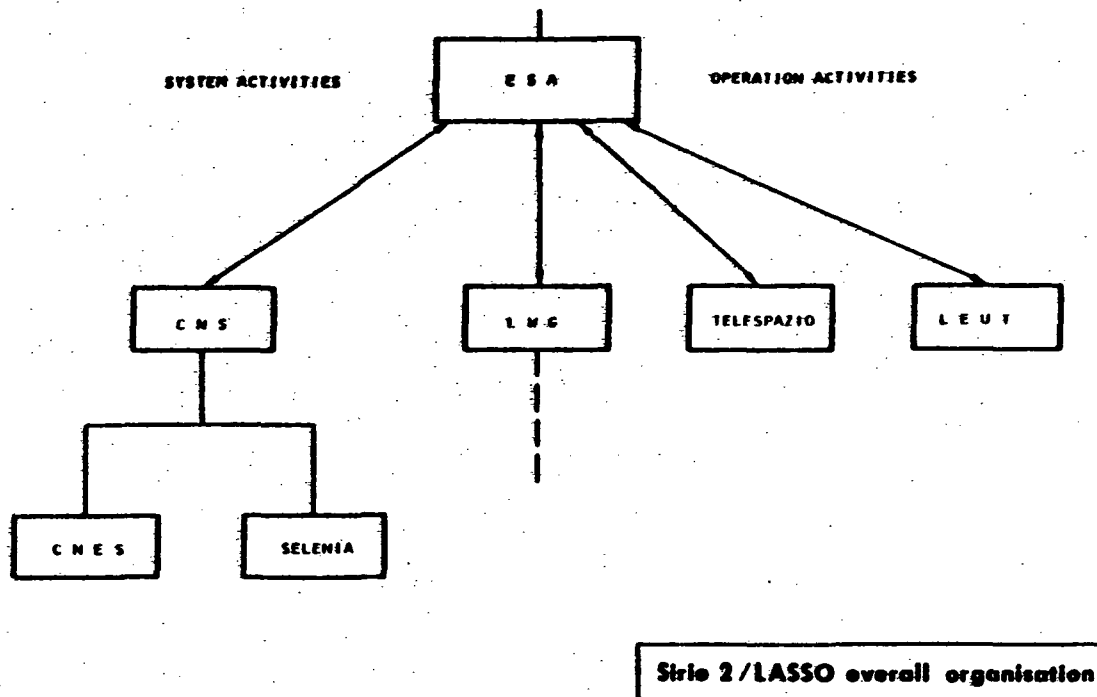

FIGURE 8

The LASSO Working Group (LWG), which is composed of seven European scientists, has been created to advise ESA on the validity of the proposed participation, the capabilities of existing and envisaged laser stations, and potential LASSO applications (time and frequency, geodesy, geophysics).

The LASSO Experimenters and Users Team (LEUT) is composed of the principal investigators of the admitted experiments. The purpose of the group is to clear the technical and operational interfaces between the ESA-provided services and the users intentions. It also enables the users themselves to be involved at the very beginning of the experiment coordination process.

The SIRIO-2/LASSO operational organisation is given in Figure 9.

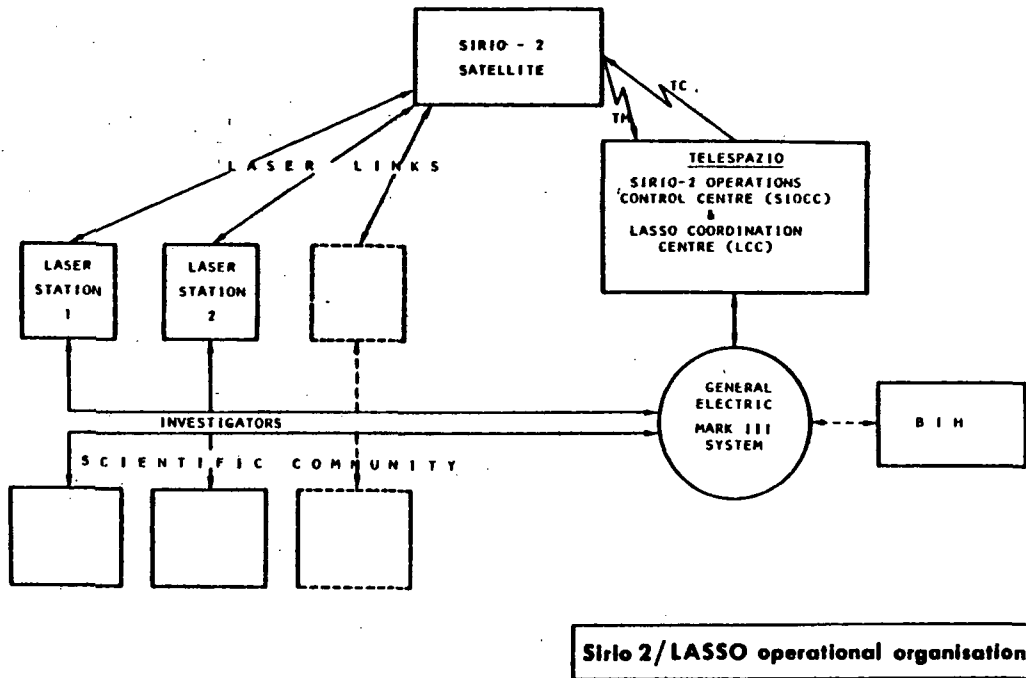

FIGURE 9

3.1. The Scientific Community

The Announcement of Opportunity was issued by ESA in September 1979 and distributed worldwide. Replies were received and analysed with the support of the LWG during the first quarter 1980. Provisional admittances were notified to the principal investigators, and two LEUT meetings were held in June and September 1980.

The provisional list of participants in the LASSO mission is given in Table 2.

Country	Entrusted Laboratory	Principal Investigator	Laser Station	Status
Austria	U.T. Graz	Prof. W. Riedler	Lustbühel	Purchase in progress
Brazil	CNPq	P. Mourilhe Silva		Information not available
France	GRGS BIH LPTF	Dr. F. Barlier	Grasse	Operational
E.Germany	Academie der Wissenschaften	Dr. G. Hemmleb	Potsdam	Operational
W.Germany	PTB IFAG	Dr. G. Becker	Wetzell	Operational
India	NPL STARS	Dr. B.S. Mathur Dr. P.S. Dixit	Kavalur	Under refurbishment
Italy	Cagliari Obs. OAT IEN Univ. Pavia	Prof. E. Proverbio Prof. M.G. Fracastoro Prof. B. Bertotti	Cagliari Turino n.a.	" " Purchase in progress off-line
Netherlands	Van Swinden U.T. Delft	Dr. R. Kaarls	Kootwijk	Operational
Spain	Instituto y Obs. de Marina	J. Benavente	San Fernando	Under refurbishment
U.S.A.	USNO NASA GSFC NBS Univ. Maryland Dept. of Navy	Dr. G.M.R. Winkler Dr. R.J. Anderle	NASA GSFC n.a.	Operational off-line
ESA	ESOC	W. Flury & J.M. Dow	n.a.	off-line

TABLE 2

The LASSO Principal Investigators are undertaking preparatory work for LASSO participation in the following typical areas :

- adaptation of laser station equipment (e.g. acquisition of datation timers, modification of laser beam width, intensity, pulse length);
- preparation of computer software for time synchronisation calculation and geophysical or orbitographical analysis;
- affiliation to the General Electric Mark III System for data exchange;
- attendance at the LASSO Experimenters and Users Team (LEUT) meetings organised by ESA.

3.2. The L.C.C.

Telespazio has been requested to prepare for the set-up, operation and maintenance of the LCC for the purpose of :

- (i) experiment preparation (hours, minutes before daily laser transmission session), including :
 - orbit determination,
 - S/C spin phase prediction,
 - laser firing times,
 - telescope pointing angles,
 - dissemination and acknowledgment;
- (ii) experiment monitoring (during daily session) :
 - LASSO telemetry real-time analysis,
 - operational feedback to/from laser stations,
 - updating of operational modes (e.g. phasing of transmissions);
- (iii) compilation and annotation of data (after daily sessions) :
 - LASSO telemetry preprocessing to correlate timing with stations,
 - laser station timing data,
 - orbital ranging data,

- S/C spin phase information,
- session narrative summary;

(iv) dissemination and archiving of results.

3.3. Communication System

Data exchange between LCC, laser stations, time institutes and research laboratories will, as far as practicable, take place using the worldwide General Electric Mark III System.

Specialised or validative data processing will be performed by various user institutes primarily to satisfy their own needs, but the results will be made available to the user community as a whole by way of the G.E. Mark III file interrogation feature.

The LCC data output will consist of laser transmission and reception times at the participating laser stations, along with the datation extracted from the satellite telemetry. The data will be distributed to principal investigators via the G.E. Mark III System.

3.4. Cooperation with the "Bureau International de l'Heure" (BIH)

The BIH has offered its cooperation with ESA in the LASSO mission in three areas :

- time comparison over long periods, by statistical treatment, for atomic clocks attached to laser stations;
- special processing allowing the participation of one-way laser stations;
- data exchange via the G.E. Mark III System.

3.5. ESA Responsibility

The LASSO principal tasks to be carried out by ESA under the SIRIO-2 Exploitation Phase during 24 months after geosynchronous orbit acquisition are :

- (a) schedule and prepare the overall LASSO mission in terms of monthly, weekly and daily activities, in liaison with participating principal investigators and laser station operators;

- (b) build, operate and maintain a LASSO Coordination Centre (LCC);
- (c) collaborate with LASSO Principal Investigators in the calculation of time asynchronisms among participating atomic clocks with the aim of demonstrating the feasibility of achieving a precision of one nanosecond or better;
- (d) transport and maintain a transportable calibration device in order to monitor secular drift phenomena in the laser transmission and reception equipment at participating laser stations;
- (e) evaluate and report on the performances of the LASSO mission in comparison with other space and ground methods for time transfer.

4. CONCLUSION

The testing of the LASSO qualification model and the manufacturing of the flight model hardware is progressing in a satisfactory manner.

The LASSO mission implementation is facilitated by the overwhelming support of users, consisting mainly of laser station operators, time and frequency institutes, and researchers in the field of geodesy and geophysics.

The LASSO exploitation is benefitting from the fact that the users have developed, over the years, an informal but well-established scientific and operational relationship as a result of earlier land and space programmes.

Accordingly, users in Europe, America and Asia are undertaking procurement or adaptation of ground hardware, along with software development, in order to render the LASSO mission and their own participation as fruitful and rewarding as possible.

- o0o -

QUESTIONS AND ANSWERS

PROFESSOR CARROLL ALLEY, University of Maryland

Could you give us more details on the results of the testing, particularly as to the minimum detectable signal in the presence of maximum Albedo and in the presence of minimum Albedo?

DR. SERENE:

Well, I am surprised you have any questions, Professor, but no I don't have this information here. Have you any problem concerning the detection level? Because as far as I understand you plan to use a quite powerful laser and you have more problem to avoid destroying the equipment on-board than to know the threshold.

PROFESSOR ALLEY:

We need to know both. Let me go a bit further. You reported that the false alarm turns out to be at a rate of less than one per hour, whereas the specifications call for one per minute. This suggests to me that perhaps the threshold levels for detection is set higher than it might be necessary and that one might have a better sensitivity if one adjusted that.

DR. SERENE:

Well, the threshold detection is just to avoid filling the memory with any stray lights, but actually that is not involved in the threshold for the detection of the laser pulse because we have two modes. The normal mode and the sensitive mode on-board, and I don't see the point, because the spec for one false detection per minute is more to limit electronic noise than light noise.

PROFESSOR ALLEY:

Well, I would think that they would get mixed up at the final level. Perhaps we should continue this discussion elsewhere.

DR. SERENE:

Yes, no problem. But, we can have electronic noise and passive light. That is where the false detection comes from, because if you have something recorded in the memory perhaps not coming from the detection, but coming by electromagnetic coupling that is a false detection. It has nothing to do with the threshold.

PROFESSOR ALLEY:

Well, I think this is not the forum to continue this detail but let us continue it later.