

THE OPERATIONAL PERFORMANCE OF  
HYDROGEN MASERS IN THE DEEP SPACE NETWORK  
(The Performance of Laboratory Reference  
Frequency Standards in an Operational Environment)

Samuel C. Ward

Frequency and Time System Cognizant Operations Engineer  
Jet Propulsion Laboratory, Pasadena, California

ABSTRACT

Spacecraft navigation to the outer planets (Jupiter and beyond) places very stringent demands upon the performance of frequency and time (F&T) reference standards. The Deep Space Network (DSN) makes use of hydrogen masers as an aid in meeting the routine F&T operational requirements within the 64-m antenna network (one antenna each in Goldstone, California; Madrid, Spain; and Canberra, Australia).

The operational syntonization (frequency synchronization) requirement is a  $\pm 3 \times 10^{-13}$  between any two 64-m Deep Space Stations (DSS) and a  $\pm 1 \times 10^{-12}$  between any 64-m DSS to UTC(NBS). The clock (epoch) synchronization requirement is  $\pm 20 \mu\text{s}$  64-m DSS between any two 64-m DSS, and  $\pm 20 \mu\text{s}$  offset between any 64-m DSS to the UTC(NBS) epoch.

Both the sync and the synt were established through use of a specially calibrated H-P E21-5061A Flying Clock. The sync/synt to UTC is being maintained using LORAN and TV in the simultaneous reception mode. The sync/synt within the 64-m net is maintained through the use of Very Long Base Interferometry (VLBI).

Results as of October, 1980 indicate the hydrogen masers are performing within the required specifications. However two problem areas remain that affect operations performance: (1) there is insufficient control over the environment in which the reference standards reside and, (2) frequency drift makes it very difficult to maintain the 64-m DSS to 64-m DSS synt over the 130-day period required by the flight project.

## INTRODUCTION

The "laboratory standards" are three hydrogen masers, Smithsonian Astrophysical Observatory (SAO) model VLG10B, and six cesium oscillators, Hewlett-Packard model 5061A-004 option. The "operational environment" is an isolated temperature controlled room at each of three NASA/JPL Deep Space Network (DSN) complexes.

This Precision Time and Time Interval (PTTI) application is in support of refined spacecraft navigation to the outer planets (Jupiter and beyond) and to provide wideband (>100 kilobits) telecommunications channels at S and X band. The Voyager project Navigation team guides the spacecraft to Jupiter, Saturn, Uranus, and perhaps Neptune. The Telemetry and Image Processing teams have brought us the beautiful full color pictures of the planets and their satellites. Last, the Radio Science team uses spectral analysis to detect and measure the constituents of planetary atmosphere, orbital rings, and gravimetrics.

## REQUIREMENTS AND SPECIFICATIONS

Because the Voyager project requirements are currently the most stringent, they have been the dominant force in the design of the Frequency and Time System (FTS). The requirements are: (1) the fine-spectral performance of and longterm stability of the hydrogen maser, (2) the accuracy and reliability of the cesium, and (3) some means of synchronizing the intercontinental network of tracking stations.

The specifications relating to a typical frequency and timing system using H-masers and Cs are listed in the PTTI literature, manufacturers specifications, etc. and will not be dealt with further in this paper. I will instead address the very stringent requirements for syntonization and synchronization.

### Syntonization Requirements

1. The frequency offset between any pair of 64-m Deep Space Stations (DSS) shall be known to within less than  $\pm 3 \times 10^{-13}$ , such as DSS 63 (Madrid, Spain) vs. DSS 43 (Canberra, ACT) =  $< \pm 3 \times 10^{-13}$ , or DSS 63 vs. DSS 14 (Goldstone, California) =  $< \pm 3 \times 10^{-13}$ , or DSS 63 vs. DSS 14 =  $< \pm 3 \times 10^{-13}$ .
2. The frequency offset of the DSN master (DSS 14) shall be maintained within  $\pm 3 \times 10^{-13}$  of UTC(NBS).

## Synchronization Requirements

1. The time offset between any pair of 64-m DSS shall be known within  $\pm 20 \mu\text{s}$ .
2. The time offset of any 64-m DSS from UTC shall be known within  $\pm 20 \mu\text{s}$  and further, it shall actually be maintained to within  $< \pm 50 \mu\text{s}$  over the 130-day period August 4 through December 12, 1980.

## METHODOLOGY

Both the synchronization and syntonization were established through use of a specially calibrated 5061A-001-004 portable unit<sup>1</sup>. For purposes of maintaining the individual DSS synchronization to UTC, the portable unit was carried to the host country frequency and time metrology agency. The San Fernando Observatory in Spain where the sync/synt tool used is Mediterranean chain LORAN-C. In Australia the responsible agency is the Department of National Mapping and the F&T maintenance resource is ABC television (see Figure 1). In America, at Goldstone, regular 60-day flights to and daily VLF transmissions from National Bureau of Standards are used, in addition to LORAN-C and traveling clocks from other agencies (Goddard Space Flight Center and the USNO). The DSS to DSS synchronization and syntonization is being maintained through the use of Very Long Base Interferometry (VLBI). Some of the results are reported in paper No. 21 of this session (12th PTTI). Figure 2 illustrates how the DSS to DSS and the DSN to UTC synchronization is maintained.

Each 64-m DSS has been delegated the responsibility of maintaining its own internal synchronization. Figure 3 illustrates the hardware configuration and data flow paths that achieve this. In addition it is responsible for establishing and maintaining the synchronism of other DSS within the complex (see the detail in upper and lower right hand segments of Figure 2).

---

<sup>1</sup>After allowing 24 hours for the portable 5061A to stabilize to its temperature and magnetic environment, the unit was degaussed and a measurement was made of the zeeman frequency vs. frequency offset of the unit references to the DSN master. Using a digital frequency synthesizer and a differential voltmeter, the zeeman frequency readings were reproducible within 0.7 Hz. The portable unit was then carried to the remote DSS to be syntonized. Here again the unit was given 24 hours to stabilize, was degaussed and the zeeman frequency was measured. If the zeeman changed by more than 1.4 Hz it was reset. Otherwise a correction factor of  $8.3 \times 10^{-15}/\text{Hz}$  and  $1 \times 10^{-13}/\Delta^{\circ}\text{C}$  was applied to the syntonization.

## TEST RESULTS

### Environmental Tests

Table 1 lists the results of environmental tests performed on five of the six 5061A cesiums presently deployed within the DSN. These tests were performed at the Reference Standards Test Facility in Pasadena. Note that serial No. 1718 in its response to temperature variations differed from the others. When this unit was sent to the Goldstone Reference Standards Laboratory for zeeman calibration, it exhibited phase glitches. It was returned to Pasadena for further environmental testing.

Table 2 lists the results of environmental tests performed on the three hydrogen masers presently deployed within the DSN. Figure 4 illustrates the behavior of H-maser SAO serial No. 6 in a changing pressure environment. Note the improvement (8.2 dB) in its performance after being refurbished (Table 2, column 6).

Figure 5 illustrates the performance of SAO serial No. 7 in a changing magnetic environment. Having been given erroneous information on how far the 26-m antenna was from the planned site for the frequency standards room, it was decided that no further magnetic shielding would be required. SAO serial No. 6 failed in spring 1980 and was returned to the manufacturer for refurbishment. Table 2, column 5 indicates a 2.7 dB degradation to its performance in a changing magnetic environment.

Figure 6 illustrates the performance typical of a H-maser in a high temperature environment. The H-maser is JPL serial No. 1 and the environment was an unventilated room in the cellar of DSS 43. The high temperatures caused the unit to fail in late summer (southern hemisphere). An air conditioner with 0.1°C temperature control was installed early September 1980.

### Stability Tests

Figure 7 illustrates the short term stability (spectral performance) of a typical 5061A-004 cesium and a typical H-maser. These measurements were made in Spain at DSS 63 where the Complex Maintenance Facility (CMF) was close enough to permit use of a coaxial cable from the H-maser. Cesium serial No. 1511 was the portable unit and it was carried to the CMF facility.

Table 1. Cesium Environmental Parameters Test Data

PARAMETER	HEWLETT-PACKARD 5061-A 004				
	#1694	#1695	#1717	#1718	#1719
TEMPERATURE $\frac{\Delta F}{F} / ^\circ C$	$4.3 \times 10^{-14}$	$6.25 \times 10^{-14}$	$5.4 \times 10^{-14}$	$1.2 \times 10^{-13}$ TO $-2 \times 10^{-13}$	$5.6 \times 10^{-14}$
BAROMETRIC PRESSURE $\frac{\Delta F}{F} / \text{"Hg}$	$1 \times 10^{-13}$	$1 \times 10^{-13}$	$1 \times 10^{-13}$	$1 \times 10^{-13}$	$1 \times 10^{-13}$
MAGNETIC FIELD $\frac{\Delta F}{F} / \text{GAUSS}$	$1 \times 10^{-13}$	$1 \times 10^{-13}$	$1 \times 10^{-13}$	$1 \times 10^{-13}$	$1 \times 10^{-13}$

Table 2. H-Maser Environmental Parameters Test Data

PARAMETER	(AFTER REFURBISH BY MFR)				
	SAO 5	SAO 6	SAO 7	SAO 5	SAO 6
TEMPERATURE $\frac{\Delta F}{F} / ^\circ C$	$-1.6 \times 10^{-14}$	$-1 \times 10^{-13}$	$7.0 \times 10^{-14}$	$-1.2 \times 10^{-13}$	$7.2 \times 10^{-14}$
BAROMETRIC PRESSURE $\frac{\Delta F}{F} / \text{"Hg}$	$2.6 \times 10^{-14}$	$-3.4 \times 10^{-13}$	$2.3 \times 10^{-14}$	$2.5 \times 10^{-14}$	$-5.1 \times 10^{-14}$
MAGNETIC FIELD $\frac{\Delta F}{F} / \text{GAUSS}$	$1.6 \times 10^{-12}$	$5.0 \times 10^{-12}$	$2.8 \times 10^{-12}$	$3.0 \times 10^{-12}$	$3.4 \times 10^{-12}$

Figures 8a and 8b give the stability performance characteristics of the three H-masers presently deployed<sup>2</sup>. Figure 9 illustrates the stability characteristics of a recent series (serial Nos. 1718 and 1719) of 5061A-004 cesium.

## SYNCHRONIZATION AND SYNTONIZATION DATA

### Epoch Synchronization

Prior to departure for the trip to Spain the portable clock designated RSL-2 was used to synchronize itself and the DSN master clock at DSS 14 to within  $0.2 \mu\text{s}$  of the NBS and USNO epoch. It was then transported to DSS 63 at Robledo, Spain then on to the San Fernando Observatory (SFO) at San Fernando, Spain. One day prior to leaving Spain the clock was transported to DSS 62 at Cebreos and the Madrid STDN station. Thus the three stations in the Madrid complex were synchronized to SFO and the DSN master to less than one  $\mu\text{s}$ .

Upon returning to America the clock was immediately taken to Goldstone for closure against the DSN master. It then was taken to Australia where it was used to synchronize DSS 43 at Tidbinbilla to the Dept. of National Mapping (DNM) installation in the Orroral Valley. On the day prior to leaving Australia the portable clock was used to synchronize DSS 44 (Honeysuckle Creek) and Orroral (the STDN station) to the DNM, DSS 43, and the DSN.

The portable, RSL2, was then returned to America where closure was refined against both NBS and USNO. All the elements and agencies synchronized on these trips remain synchronized to within less than one  $\mu\text{s}$  and are being maintained within 10  $\mu\text{s}$  peak to peak.

### Syntonization

Each time the calibration process was performed, 24 hours was allowed for thermal stabilization and then 80 hours (10 8-hour samples) of comparative phase data was collected. This was performed with instrumentation configured as in Figure 3 except that a 4th phase comparator was added to permit the intercomparison of the H-maser, Cs No. 1, Cs No. 2 and the portable (RSL2).

At DSS 63 after settling from the trauma of the trip and after thermal stabilization the zeeman frequency of RSL2 had shifted but 1.7 Hz. A C-field adjustment removed approximately 1/2 the zeeman offset and the

---

<sup>2</sup>Figures 8a and 8b have been reprinted from a paper presented by Paul Kuhnle at the 11th Annual PTTI.

calibration process of the H-maser began. At the end of the 88-hour calibration period the H-maser frequency offset from the DSN master was found to be zero  $\pm$  the instrumentation noise of  $\pm 5 \times 10^{-14}$ . It was thus unnecessary to make any adjustment to the H-maser. It was however necessary to adjust both Cs No. 1 and Cs No. 2. Data collected via LORAN-C indicates the frequency offset of the H-maser and Cs No. 2 remain at zero  $\pm 4.8 \times 10^{-13}$  as of November 8, 1980.

At DSS 43 the thermal stabilization period was extended to allow for the lack of good circulation (the air handler installation was still in process). Also the H-maser had been installed just a few weeks and was still drifting. At the end of an 80-hour calibration period the offset of the maser from the DSN master was  $4.73 \times 10^{-13}$ . Since this was beyond the Voyager specification and, since the drift was in a positive direction, the H-maser synthesizer was reset to reduce its frequency by  $6.345 \times 10^{-13}$ . Frequency offset data of this maser vs. UTC(AUS) collected using simultaneous TV with the DNM indicate its drift has cancelled the value reset on September 30. Close examination of recent data indicate the 2nd order drift term has dropped from  $4.6 \times 10^{-14}$ /day to  $2.1 \times 10^{-14}$  to  $0.7 \times 10^{-14}$ /day.

All indications are that the frequency drift of SAO No. 5, the DSN master, has dropped well below its former value of  $1 \times 10^{-14}$ /day as observed between departure for Spain and return for closure. At present SAO No. 5 vs. UTC(NBS) =  $-2.84 \times 10^{-13} \pm 0.3$  as verified by two closures against UTC(NBS) within a 21-day period. Figure 10 gives time offset data vs. UTC(DSN) and associated frequency offset data for each of 3 64-m DSS. Figure 11 gives time offset data vs. UTC(NBS&USNO) and the associated frequency offset data vs. UTC(NBS) of the DSN master reference.

#### SUMMARY

- (1) Hydrogen masers require 4 to 6 weeks thermal stabilization time before their long-term stability can be fully utilized.
- (2) To fully utilize the full potential of present day H-masers and cesium reference frequency standards, care must be exercised in providing a thermally stabilized and magnetically isolated environment.
- (3) Syntonization to UTC can be accurately and economically maintained within a part in  $10^{13}$  (after 1 week of daily observations) through use of the simultaneous reception of LORAN-C or TV transmissions by the DSS and the host country frequency and time metrology agency.

UTC (DSN) - UTC (NBS) vs UTC (DSN) - UTC (USNO) VIA UTC (AUSTRALIA)

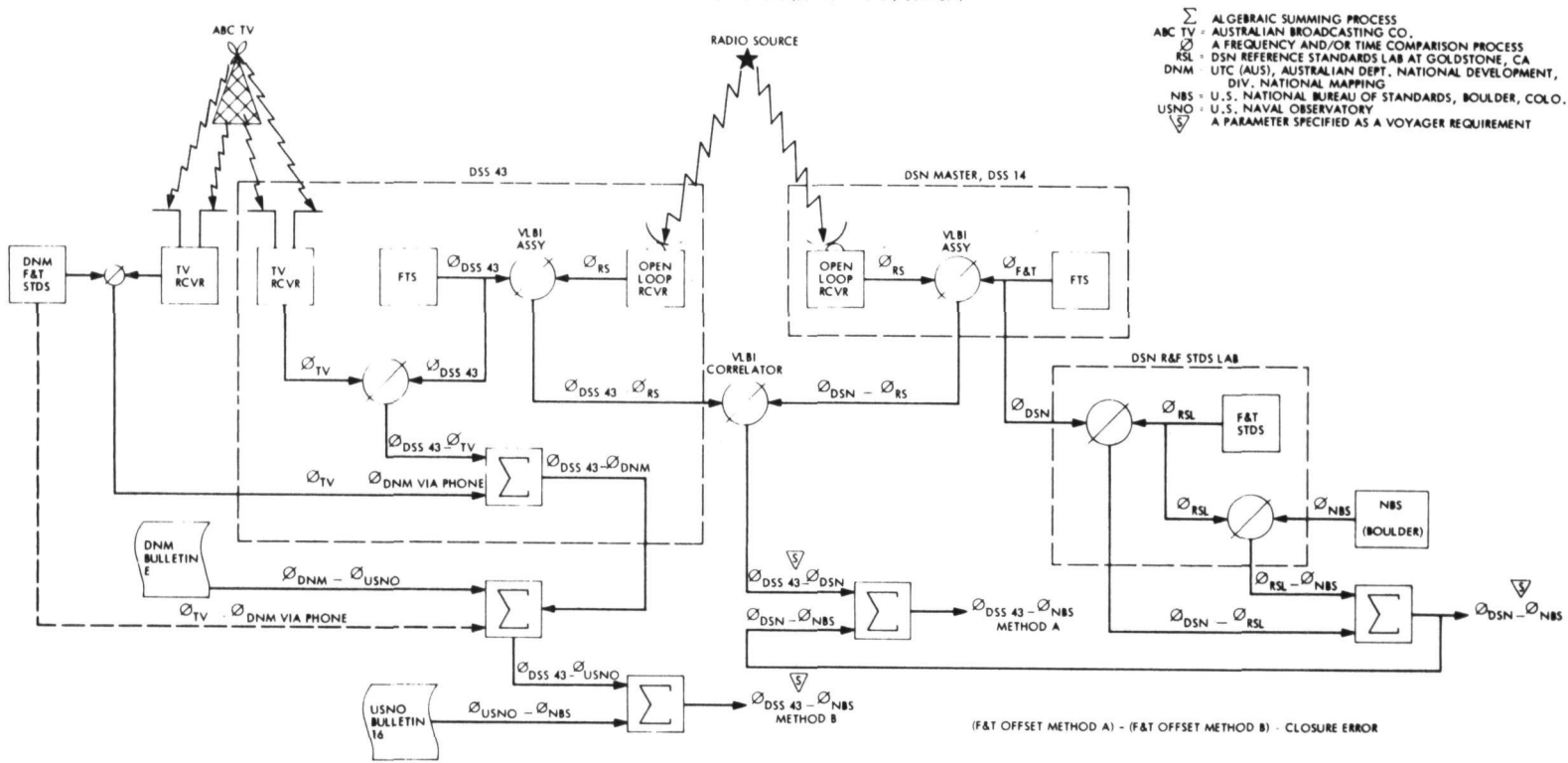

Figure 1. UTC(DSN) - UTC(NBS) vs. UTC(DSN) - UTC(USNO) via UTC (Australia)



NASA/JPL INTRA/EXTRA DSN FREQUENCY & TIME SYNC SYSTEM

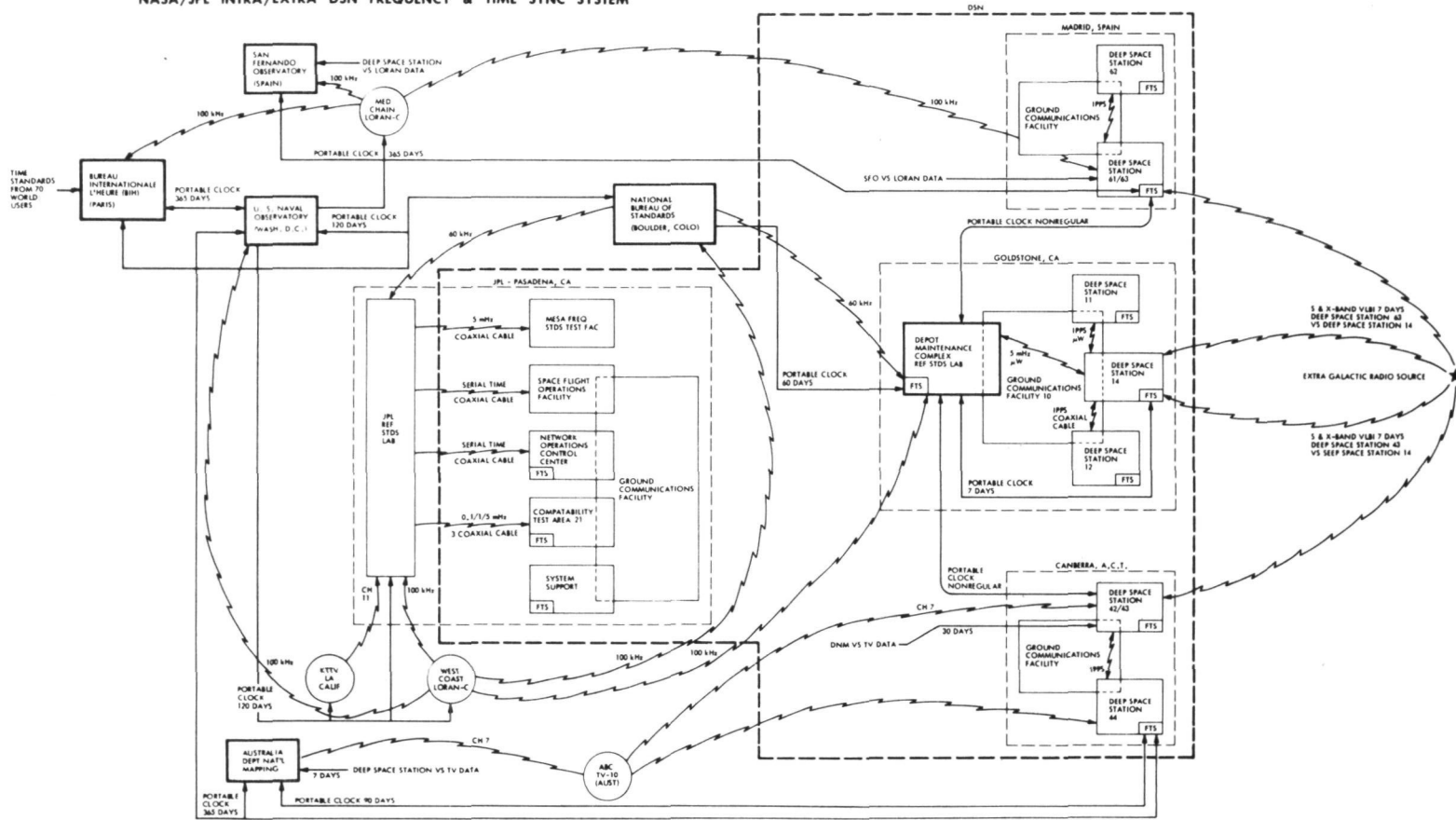

Figure 2. NASA/JPL Intra/Extra DSN Frequency and Time Sync System

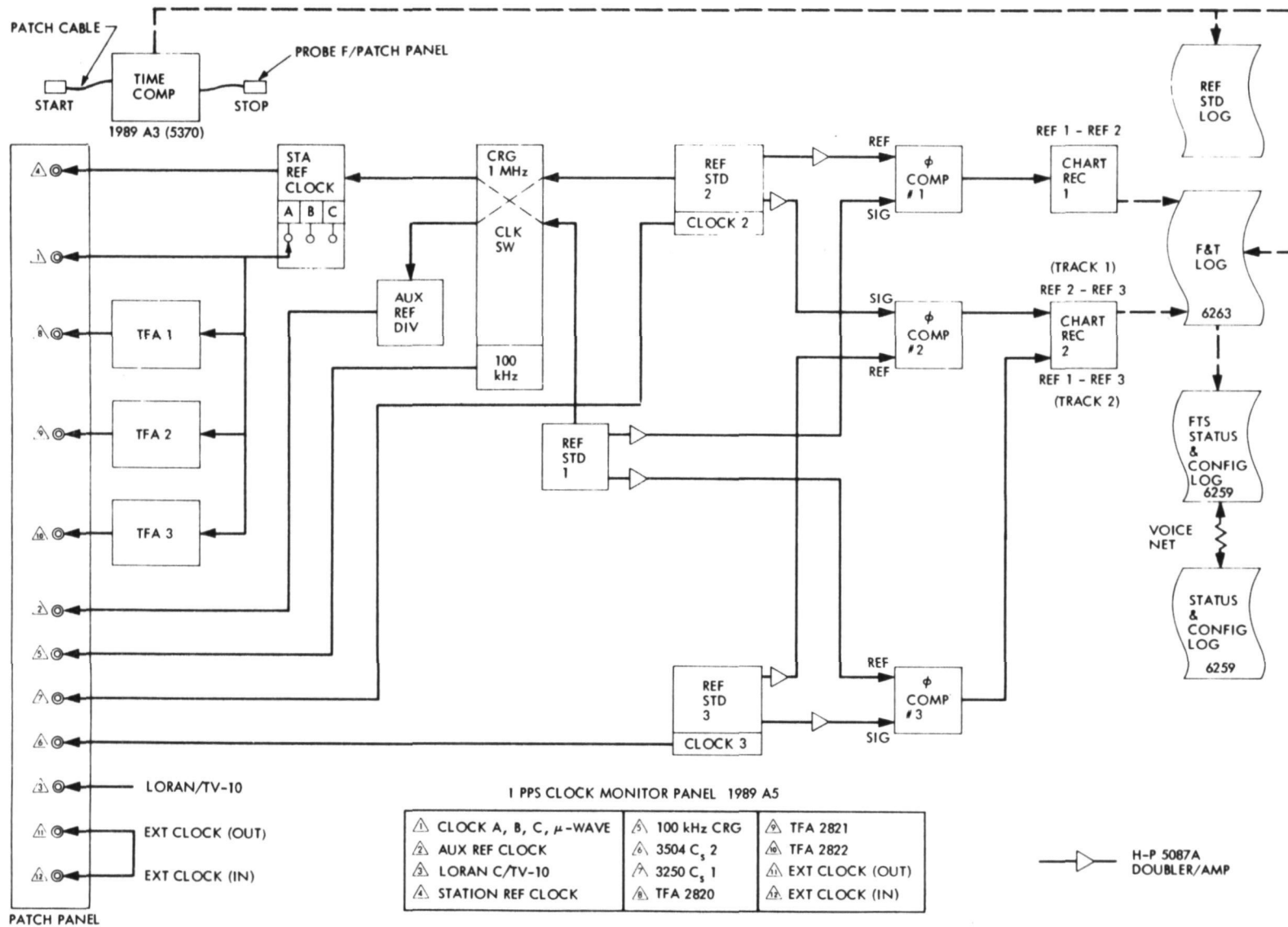

Figure 3. Frequency and Time Monitoring at 64-m DSS

DSS 14 vs UTC (NBS) via MICROWAVE AND PORTABLE CLOCKS

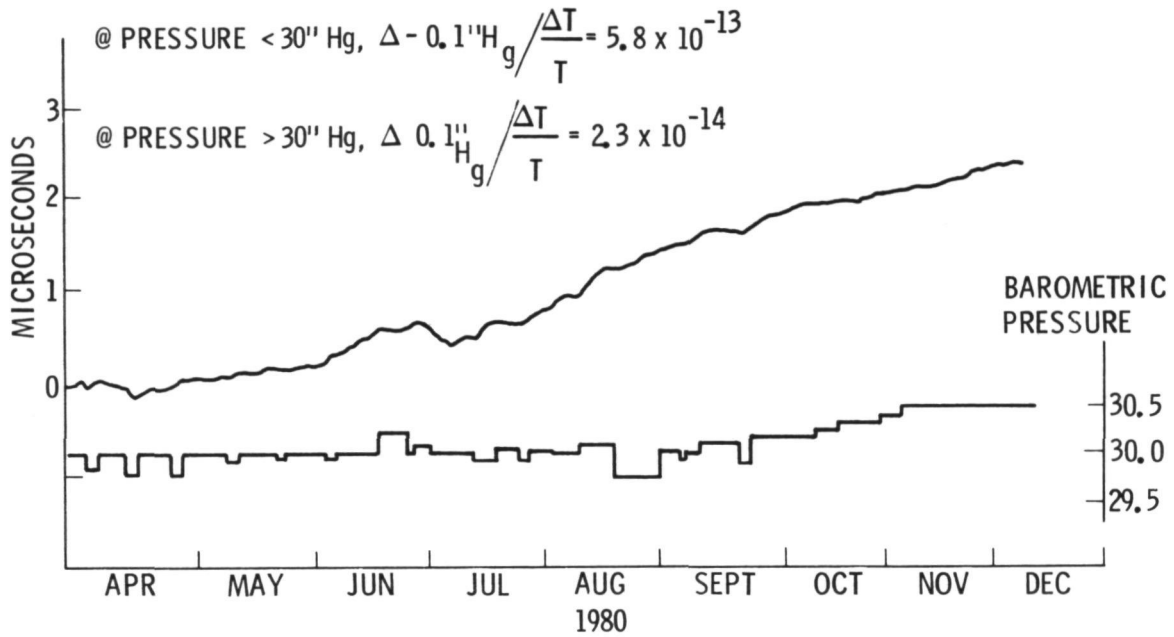

Figure 4. H-Maser Performance in a Changing Barometric Pressure Environment

DSS 63 vs UTC (USNO) via LORAN-C, MED. CHAIN

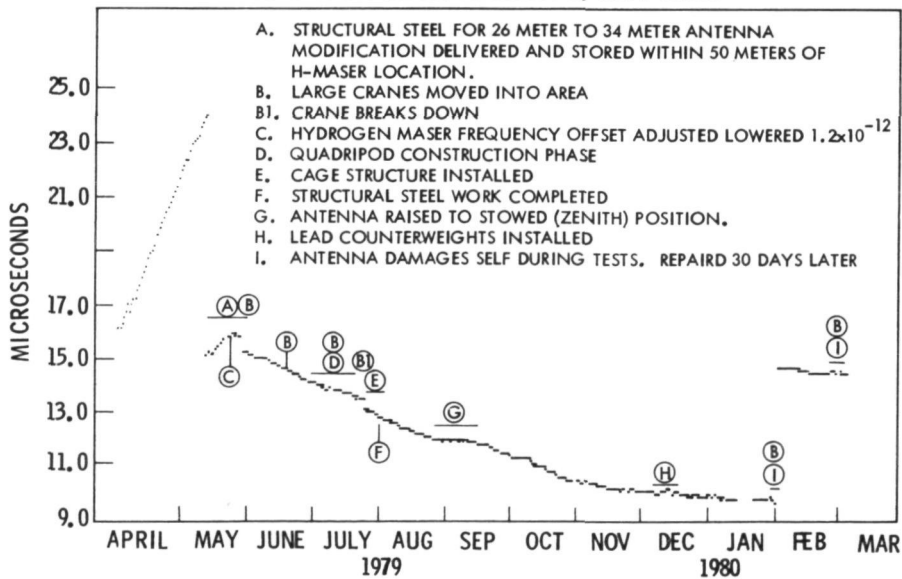

Figure 5. H-Maser Performance in a Changing Magnetic Environment

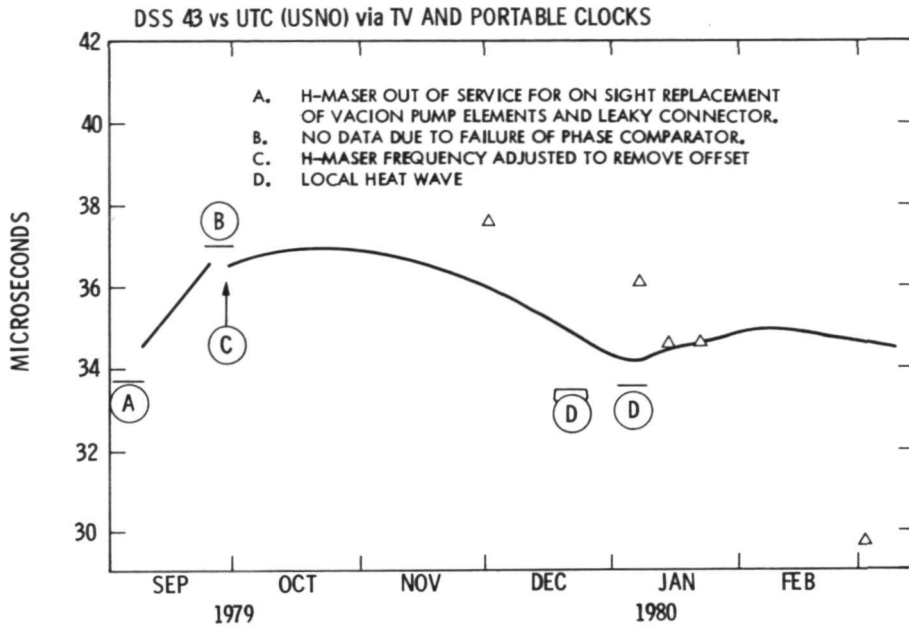

Figure 6. Maser Performance in a Changing Temperature Environment

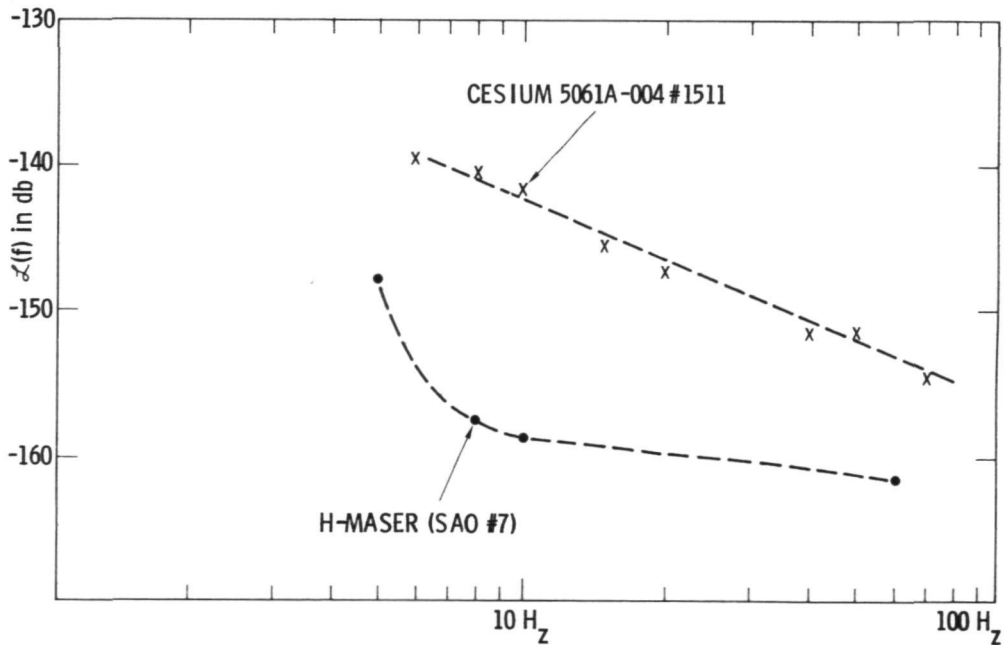

Figure 7. Reference Standards Spectral Performance,  $L(f)$  vs. Frequency

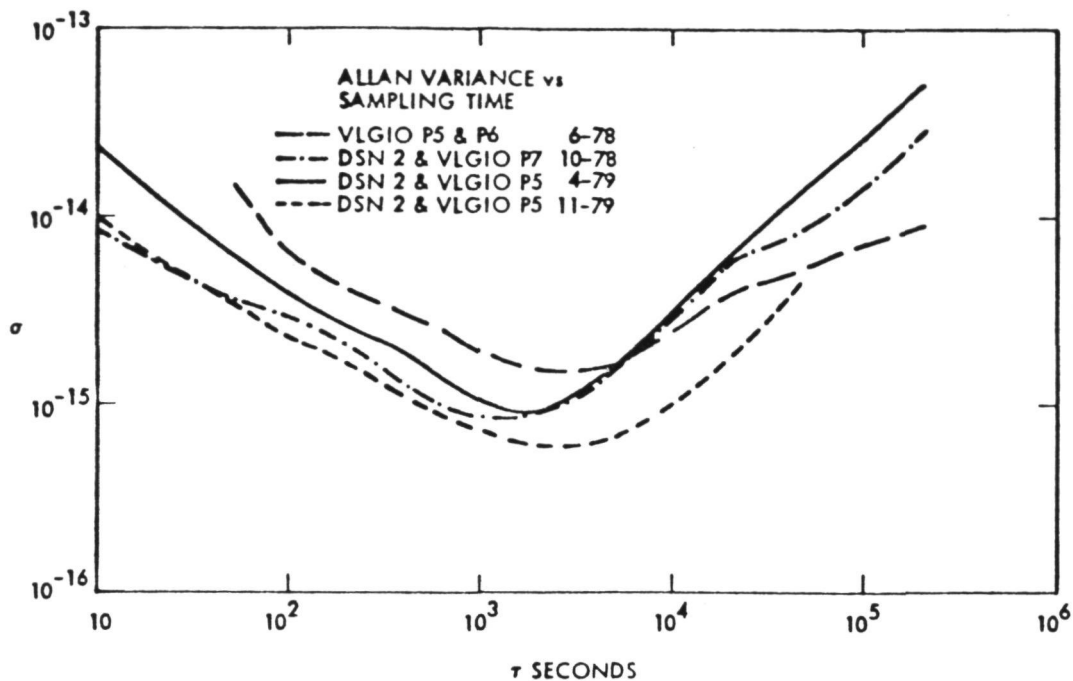

Figure 8a. Allan Variance vs. Sampling Time

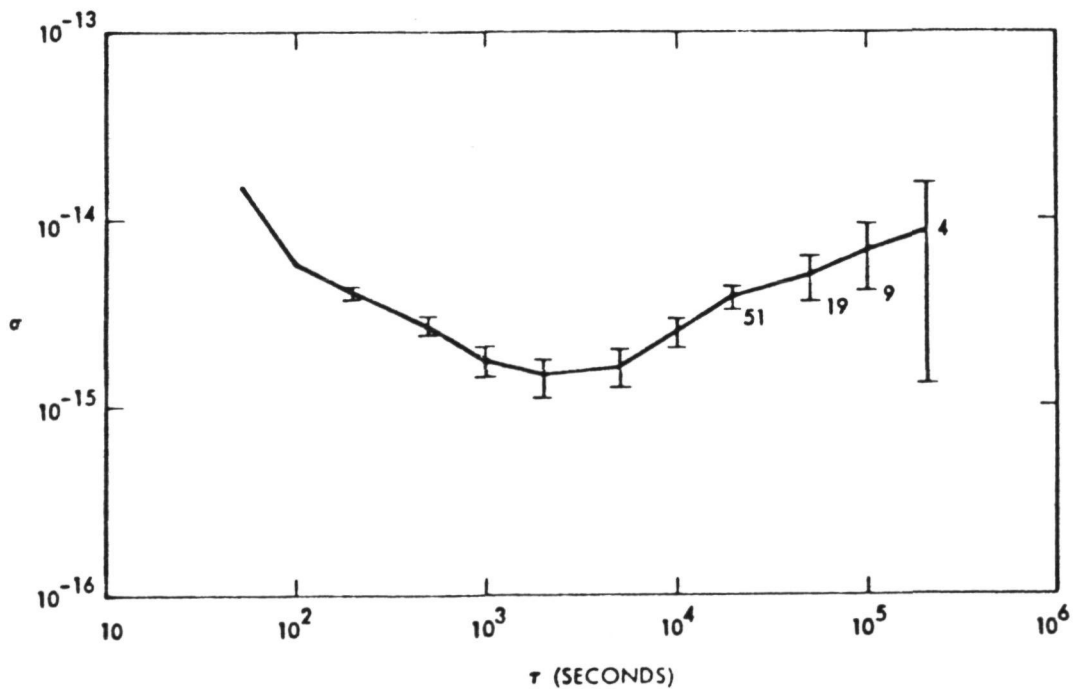
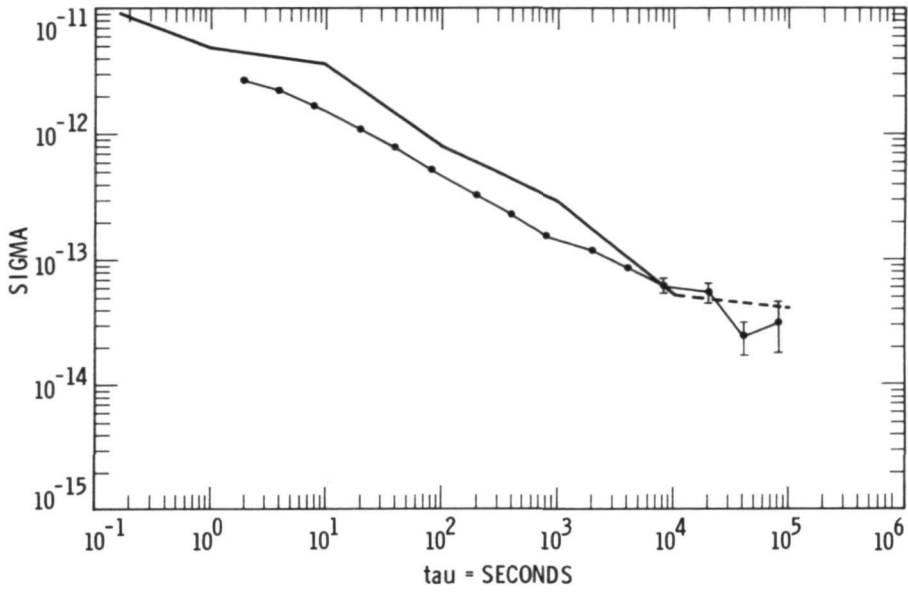

Figure 8b. Allan Variance vs. Sampling Time, with Error Bars

RUN: 92.1A      N = 2      DSN2 - Cs 1718      START: 1630: 10-17-80  
 TSEP: 2.10      T = tau      END: 1345: 10-21-80  
 ALLAN VARIANCE      B = 1 Hz      CHANNEL: 1  
 SIGMA (N, T, B, tau)      f<sub>o</sub> = 100.0 MHz      DSN2 = H MASER  
 — = H-P SPEC



RUN: 81.18      N = 2      DSN3 - Cs 1719      START: 1410: 07-03-80  
 TSEP: 2.20      T = tau      END: 0800: 07-07-80  
 ALLAN VARIANCE      B = 1 Hz      CHANNEL: 3  
 SIGMA (N, T, B, tau)      f<sub>o</sub> = 5.00 MHz      J2-101704  
 — = H-P SPEC      DSN3 = H MASER

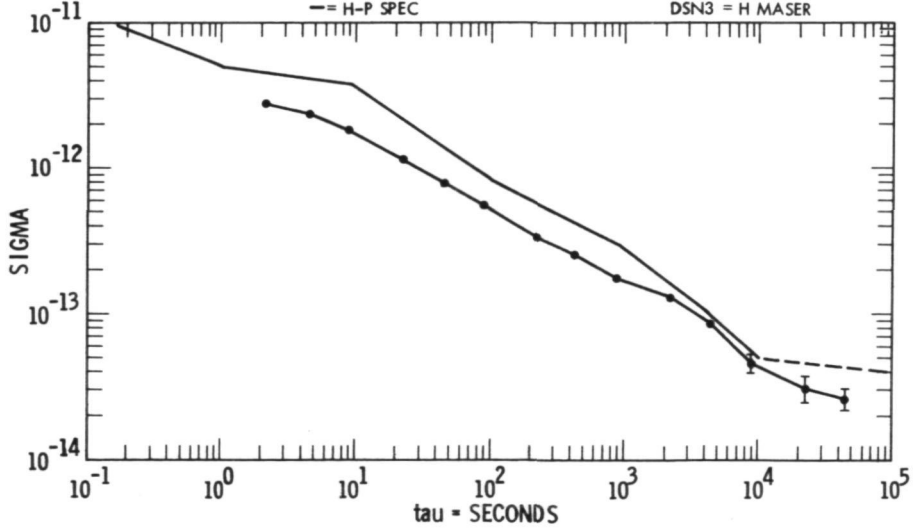

Figure 9. Stability Test Data

FTS Quicklook Data

DOY	DSS-14		DSS-42/43		DSS-61/63	
	T.O. ( $\mu$ s)	Rel. Rate ( $\mu$ s/ $\mu$ s)	T.O. ( $\mu$ s)	Rel. Rate ( $\mu$ s/ $\mu$ s)	T.O. ( $\mu$ s)	Rel. Rate ( $\mu$ s/ $\mu$ s)
286	0.00	-----	-2.70	-----	2.3	-----
287	0.00	0.0	-2.70	0.0	2.3	0.0
288	---	-----	-2.67	3.47 (-13)	2.2	-1.16 (-12)
289	0.00	-----	-2.63	4.63 (-13)	2.3	1.16 (-12)
290	0.80	9.26 (-12)	-2.60	3.47 (-13)	2.3	0.0
291	0.80	0.0	-2.56	4.63 (-13)	2.2	-1.16 (-12)
292	0.80	0.0	-2.52	4.63 (-13)	2.2	0.0
293	1.00	2.31 (-12)	-2.49	3.47 (-13)	2.3	1.16 (-12)
294	0.80	-2.31 (-12)	-2.44	5.79 (-13)	2.4	1.16 (-12)
295	1.20	4.62 (-12)	-2.41	3.47 (-13)	2.4	0.0
296	0.80	-4.62 (-12)	-2.38	3.47 (-13)	2.3	-1.16 (-12)
297	0.80	0.0	-2.34	4.63 (-13)	2.3	0.0
298	-0.30	-1.27 (-11)	-2.31	3.47 (-13)	2.4	1.16 (-12)
299	-0.30	0.0	-2.27	4.63 (-13)	2.4	0.0
300	-0.20	1.16 (-12)	-2.24	3.47 (-13)	2.5	1.16 (-12)
301	-0.30	1.16 (-12)	-2.20	4.63 (-13)	2.4	1.16 (-12)
302	-0.28	2.31 (-13)	-2.17	3.47 (-13)	2.4	0.0
303	-0.30	-2.31 (-13)	-2.13	4.63 (-13)	2.4	0.0
304	-0.30	0.0	-2.10	3.47 (-13)	2.3	1.16 (-12)
305	-0.35	-5.79 (-13)	-2.06	4.63 (-13)	2.3	0.0
306	-0.40	-5.79 (-13)	-2.03	3.47 (-13)	2.3	0.0
307	-0.30	1.16 (-12)	-2.00	3.47 (-13)	2.3	0.0

Considering weekly segments:

Over	$T_e - T_s$	Rel. Rate	$T_e - T_s$	Rel. Rate	$T_e - T_s$	Rel. Rate
286-293	1.00	1.45 (-12)	0.21	3.04 (-13)	0.0	0.0
293-300	-1.20	1.74 (-12)	0.25	3.62 (-13)	0.20	2.89 (-13)
300-307	-0.10	1.45 (-13)	0.24	3.47 (-13)	-0.20	-2.89 (-13)

Figure 10. 64-Meter DSS F&T Offset Report

jjl →

INCOMING MESSAGE

#  
GJP053A  
RR JJPL JHIL JZED  
DE JGLD 014  
12/1714Z  
FM W WOOD/J W MYERS  
TO JJPL/S WARD/J LUVALLE/J MANKINS  
INFO JJPL/R COFFIN/R LATHAM/T TAYLOR  
JHIL/K BEUTLER/J C LAW  
JZED/NET ANALYSIS  
DLD/R RUXLOW/B MCPARTLAND/J MCCOY

SUBJECT: UTC(RSL) - UTC(NBS) EPOCH TIME SYNCRONIZATION.

TWO PORTABLE CLOCK TRIPS TO BOULDER, COLO. IN OCTOBER ALLOWED US TO REFINING THE ESTIMATE OF OUR TIME AND FREQUENCY OFFSETS TO NBS, USNO, AND B.I.H.

1. PUBLISHED DATA, AND DERIVATIONS BASED ON PUBLISHED DATA:  
(NBS TIME & FREQUENCY BULLETIN 274, USNO SERIES 7-669)  
UTC(USNO) - BIH =  $-0.694 \times 10^{-13}$   
UTC(USNO) - UTC(NBS) =  $-0.9513 \times 10^{-13}$   
TA NBS - UTC(NBS) =  $-0/0143 \times 10^{-13}$   
TA NBS - BIH =  $+0.243 \times 10^{-13}$  (+/-  $0.279 \times 10^{-13}$ )

2. RESULTS OF MEASURED DATA:

	DAY 281	DAY 302	$\Delta F/F \eta s/DAY$
RSL2-UTC(RSL) =	-0.244US	+0/182US	
RSL2-UTC(NBS) =	+0.103US	+0.349US	
UTC(RSL)-UTC(NBS) =	+0.347US	+0.166US	-8.658
UTC(RSL)-UTC(USNO) =	+0.788US	+0.799US	-0.431
CS1 14-UTC(NBS) =	+0.487US	+0.374US	-5.2546
CS1 14-UTC(USNO) =	+0.928US	+0.987US	+2.7656
CLOCK 'A' 14-UTC(NBS) =	+2.168US	+1.641US	-24.574
CLOCK 'S' 14-UTC(USNO) =	+2.609US	+1.995US	-16.326
H2M14-UTC(NBS) =	NA	NA	-26.604
H2M14-UTC(USNO) =	NA	NA	-18.304

NOTE: THE H2M(14) FREQUENCY OFFSET IS TAKEN FROM THE PHASE RECORDER COMPARISON TO CS1 14, AND IS OVER THE SAME PERIOD AS THE CLOCK CLOSURES TO NBS. NOTE ALSO THAT CLOCK 'A' 14 (DRIVEN BY THE H2M) IS PROBABLY A MORE PRECISE ESTIMATE OF THE H2M POSITION.

REGARDS

Figure 11. DSN Master Frequency and Time Report



## QUESTIONS AND ANSWERS

DR. VICTOR REINHARDT, NASA/Goddard

What kind of R mass errors were you getting with that difference in technique for Loran-C?

MR. WARD:

Loran-C is down in units of nanoseconds around seven or eight.

DR. REINHARDT:

Okay, that is just by the two stations hearing the same trend alert?

MR. WARD:

What they do at noon local solar noon, they both observe the same station, and take the raw offset and they exchange the data. And then 24 hours later do the same thing. And when you take that second difference all that is left is the difference in your rates in your clocks.

DR. REINHARDT:

Thank you.

CHAIRMAN BARNES:

Other questions?

MR. WARD:

Oh incidently what I didn't say we have been using the new Hewlett-Packard counter and one of the other things that is exchanged with the data is a sigma on the measurement.