

DEVELOPMENT OF A SUB-MINIATURE RUBIDIUM OSCILLATOR
FOR SEEKTALK APPLICATION

H. Fruehauf, W. Weidemann, E. Jechart
Efratom
Irvine, California

ABSTRACT

For some time now the Efratom 4-inch cubed Rubidium Oscillator has been used in numerous navigation and secure communication systems. The SEEKTALK program, however, and other programs of similar nature, present new challenges to oscillator makers in terms of warm-up time, size, power, operating environment, and unit cost in large quantities.

This paper will present our approach to these new warm-up and size challenges as well as the problems involved in these tasks. In order to define the improvements needed, a comparison will be made between the performance of the present off-the-shelf M-100 Military Rubidium Oscillator and that expected for the Sub-Miniature Rubidium Oscillator that is currently in development (called M-1000). Methods of achieving 1.5 minute warm-up will be discussed as well as improvements in performance under adverse environmental conditions, including temperature, vibration, and magnetics. Expected performance curves of the new oscillator as well as our microelectronics approach will be presented.

An attempt will be made to construct an oscillator error budget under a set of arbitrary mission conditions.

GENERAL

In order to clearly indicate the improvements that will be realized for this new M-1000 Oscillator development, Table 1 is provided to compare the off-the-shelf M-100 Oscillator with the M-1000. The SEEKTALK program spec requirements are shown as tentative design goals, pending a final Air Force spec release in early 1981. The most challenging performance requirements are (a) ultra fast warm-up, (b) MIL-E-5400 Class II temperature environment, (c) operation in a severe vibration environment and (d) our attempt to make the M-1000 less than one half the volume of

the present M-100 Oscillator. Figure 1 depicts the subject oscillators. The M-100 measures approximately 4" x 4" x 4.8" (or ~ 77 in³) and the M-1000 approximately 2.3" x 3.5" x 4" (or ~ 33 in³) with future goals toward further reduction in size.

Figure 2 is a functional block diagram of the present off-the-shelf M-100 oscillator. The highly stable output of the M-100 is obtained from a 10 MHz voltage-controlled crystal oscillator (VCXO), whose frequency is locked to an atomic frequency reference. The atomic reference is provided by the 6.834...GHz ground-state hyperfine transition of ⁸⁷Rb. The VCXO is locked to the rubidium resonant frequency f_{Rb} , at approximately 6.8 GHz, in the following manner: A microwave signal, having a frequency in the vicinity of f_{Rb} , is synthesized from the 10 MHz VCXO output. This microwave signal is used to excite rubidium atoms that are contained within a microwave cavity. The frequency synthesis scheme is designed so that the VCXO frequency is exactly 10 MHz when the microwave frequency is exactly equal to f_{Rb} . The frequency of the signal applied to the microwave cavity can be maintained equal to f_{Rb} by generating an error signal when the microwave frequency differs from f_{Rb} and using this error signal to servo the VCXO via its control voltage.

TABLE -1- SPEC COMPARISON (Sheet 1 of 7) 11-4-80				
DESCRIPTION	ANTICIPATED SEEK TALK SPEC	OFF-THE-SHELF M-100 OSC.	IN DEVELOPMENT M-1000 OSC.	REMARKS
Output	10 MHz sine wave 0.5 Vrms ± 10% 50 Ohms ± 10%	10 MHz sine wave 0.5 Vrms + 30,-10% 50 Ohms ± 10%	Same as M-100	
Input Power	<13W @ 25°C (Amb) 22-32 VDC (28 VDC Nom)	17W @ 25°C 22.5-32 VDC	Same as SEEK TALK	
		Separate Heater power available.	Separate heater power available	
Transient Protection	MIL-STD-704 Category A	MIL-STD-704 Category C	Same as M-100 (Working on a compromise 704A Spec)	704C Should be adequate for program. Pushing AF Spec change from A to C.
Warm-up Characteristics	≤ 1.5 minutes to reach 5×10^{-10} @ 25°C (Amb); <4 min. from -55°C (Amb).	< 10 minutes to reach 2×10^{-10} @ 25°C (Amb.) < 25 minutes from -55°C (Amb.)	Same as SEEK TALK	
Warm-up Power	Power available not specified with engines running.	4 min. option, ~ 100 watts.	< 100 watts; * ~ 80W typical for less than 1 minute.	* Max peak current at 32 VDC <6A

TABLE -1- SPEC COMPARISON (Sheet 2 of 7) 11-4-80				
DESCRIPTION	ANTICIPATED SEEK TALK SPEC	OFF-THE-SHELF M-100 OSC.	IN DEVELOPMENT M-1000 OSC.	REMARKS
Power On/Off Cycling (Retrace)	$\leq 1 \times 10^{-5}$ with off times < 1 hr.	Retrace within few parts in 10^{11}	Same as M-100	
Operating Temperature	< 5×10^{-10} from -55°C to +55°C Amb 71°C Amb. for 30 min Prefer Class II -55°C to +71°C Amb. 95°C Amb. for 30 min.	< 4×10^{-10} from -55°C to ~+60°C Amb; (+68°C Baseplate). Parts in 10^9 offset at 71°C Amb. Ops	< 3×10^{-10} from -55°C to +71°C Amb; (~ 80°C Baseplate) parts in 10^9 offset at 95°C Amb	
Long Term Drift	5×10^{-10} /year	< 3×10^{-11} /month < 3×10^{-10} /year 1×10^{-11} /month option available	< 6×10^{-11} /month 5×10^{-10} /year	
Short Term Stability	< 4×10^{-11} , $\tau = 1s$ < 1×10^{-11} , $\tau = 10s$ < 4×10^{-12} , $\tau = 100s$	Same	Same	
Trim Range / Adjustment	3×10^{-9}	Same	Same	

TABLE -1- SPEC COMPARISON (Sheet 3 of 7) 11-4-80				
DESCRIPTION	ANTICIPATED SEEK TALK SPEC	OFF-THE-SHELF M-100 OSC.	IN DEVELOPMENT M-1000 OSC.	REMARKS
Voltage Variation	Not specified.	< 1×10^{-11} for $\pm 10\%$ input voltage change.	Same as M-100	
Magnetic Field	Meets spec under 1×10^{-11} /Gauss	< 8×10^{-11} /gauss (worst case orientation)	< 1×10^{-11} /Gauss	Note: 1 Gauss = 79.59 AM ⁻¹
Signal to Noise (SSB 1Hz BW)	> 120 dB @ 100 Hz > 130 dB @ 1 KHz	> 120 dB @ 100 Hz > 135 dB @ 1 KHz	Same as M-100	
Harmonic / Non Harmonic	30 dB down 80 dB down	Same	Same	
Sinusoidal Vibration (operational)	< 1×10^{-10} 5-14Hz-0.10" D.A. 15-23Hz- $\pm 1g$ pk 24-52Hz-0.036" D.A. 54-500Hz- $\pm 5g$ pk	Tested to ~ 1g 20-500 Hz; parts in 10^9 at narrow critical freq.	Goal is to improve M-100 performance significantly	More testing needed to evaluate performance

TABLE -1- SPEC COMPARISON (Sheet 4 of 7) 11-4-80				
DESCRIPTION	ANTICIPATED SEEK TALK SPEC	OFF-THE-SHELF M-100 OSC.	IN DEVELOPMENT M-1000 OSC.	REMARKS
Random Vibration (operational)	< 1 x 10 ⁻¹⁰ 15-50Hz-0.02g ² /Hz 51-300Hz-+4dB/oct. 301-1KHz-0.1g ² /Hz 1001-2KHz-6dB/oct.	Tested to .02g ² /Hz 20-50Hz falling to .001g ² /Hz at 500Hz parts in 10 ⁶ for an Allen Variance of τ = 1 sec.	Goal is to improve M-100 performance sign.	More testing needed to evaluate performance (major design problem)
Acoustical Noise	< 1 x 10 ⁻¹⁰ MIL-STD-810 Method 515.2 Procedure I Category A	TBD - Not tested	TBD	
Storage Temp. (non-operational)	-62°C to +80 C Prefer Class II: -62°C to +95°C	-62°C to +85°C	-62°C to +95°C	
Acceleration (operational)	< 1 x 10 ⁻⁸ for 10g's in any axis.	-4 x 10 ⁻¹² /g (Worst case orientation)	< -4 x 10 ⁻¹² /g (worst case orientation)	
Temperature Altitude	MIL-E-5400 Class II < 5 x 10 ⁻¹⁰ S.L. to 70K ft 71°C to 10°C Amb.	< 1 x 10 ¹³ /mbar; with temp change < 5 x 10 ⁻¹⁰ total *	< 1 x 10 ⁻¹³ /mbar with temp change < 2 x 10 ⁻¹⁰ total **	* M-100 has not been tested to 70K ft; but expect no problems ** Vacuum Ops is goal.

TABLE -1- SPEC COMPARISON (Sheet 5 of 7) 11-4-80				
DESCRIPTION	ANTICIPATED SEEK TALK SPEC	OFF-THE-SHELF M-100 OSC.	IN DEVELOPMENT M-1000 OSC.	REMARKS
Temperature Shock	MIL-STD-810 Method 503.1 Procedure	OK	OK	
Transient Temp.	Meet Spec @ 2°C/sec from -55°C to +85°C, 71° Amb.	OK	OK	
EMI	MIL-STD-461A Notice 3 CE 01, 02, 03, 04 CS 01, 02, 06 RE 02, 04 RS 01, 02, 03	MIL-STD-461A Notice 3 CE 01, 02, 03, 04 CS 01, 02, 06 RE 02 RS 01, 02, 03	Same as M-100	RE04 not applicable.
Radiation Hardening	Not specified.	Hard to ground tactical environment of a major program.	Hardness level to be assessed.	
Reliability	MTBF>20,000 hrs. 60% DR @ 55°C Amb. Airborne uninhabited fighter environment. MIL-HDBK-217C, Not.1, Sec 2	MTBF>19,000 hrs. 60% @ 68°C base-plate Airborne inhabited transport environment MIL-HDBK-217C	MTBF>20,000 hrs. 60% @ 71°C Amb. Airborne uninhabited fighter MIL-HDBK-217C	Reliability level for unit largely controlled by hybrid screening level and can be improved accordingly.

TABLE -1- SPEC COMPARISON (Sheet 6 of 7) 11-4-80				
DESCRIPTION	ANTICIPATED SEEK TALK SPEC	OFF-THE-SHELF M-100 OSC.	IN DEVELOPMENT M-1000 OSC.	REMARKS
Humidity	MIL-STD-810 Method 507.1 Procedure III	95%	100%	
Shock (Bench Handling)	MIL-STD-810 Method 516.2 Procedure V	OK	OK	
Size	5 x 5 x 5½" max 2¼ x 2¼ x 4" Goal	<80 in ³ (3.94 x 3.90 x 4.8)	<30 in ³ (2.5 x 3.0 x 4")	
Weight	TBD	4.5 lbs. max	< 2 lbs.	
Salt Fog	MIL-STD-810 Method 509.1 Procedure 1	TBD - not tested	OK	

TABLE -1- SPEC COMPARISON (Sheet 7 of 7) 11-4-80				
DESCRIPTION	ANTICIPATED SEEK TALK SPEC	OFF-THE-SHELF M-100 OSC.	IN DEVELOPMENT M-1000 OSC.	REMARKS
Fungus Resistance	MIL-STD-454 Requirement 4	OK	OK	No test data available.
Explosive Atmosphere	MIL-STD-810 Method 511.1 Procedure 1	OK	OK	
Sand and Dust	MIL-STD-810 Method 510.1 Procedure 1	TBD - Not tested	OK	
Maintainability Requirements	~ 90% Fault Det- ection with a BITE	OK	OK	Use of lock monitor.
Shop Level Maintenance	Required	NO	NO	An atomic standard does not lend itself to de- tailed AF field level maintenance.

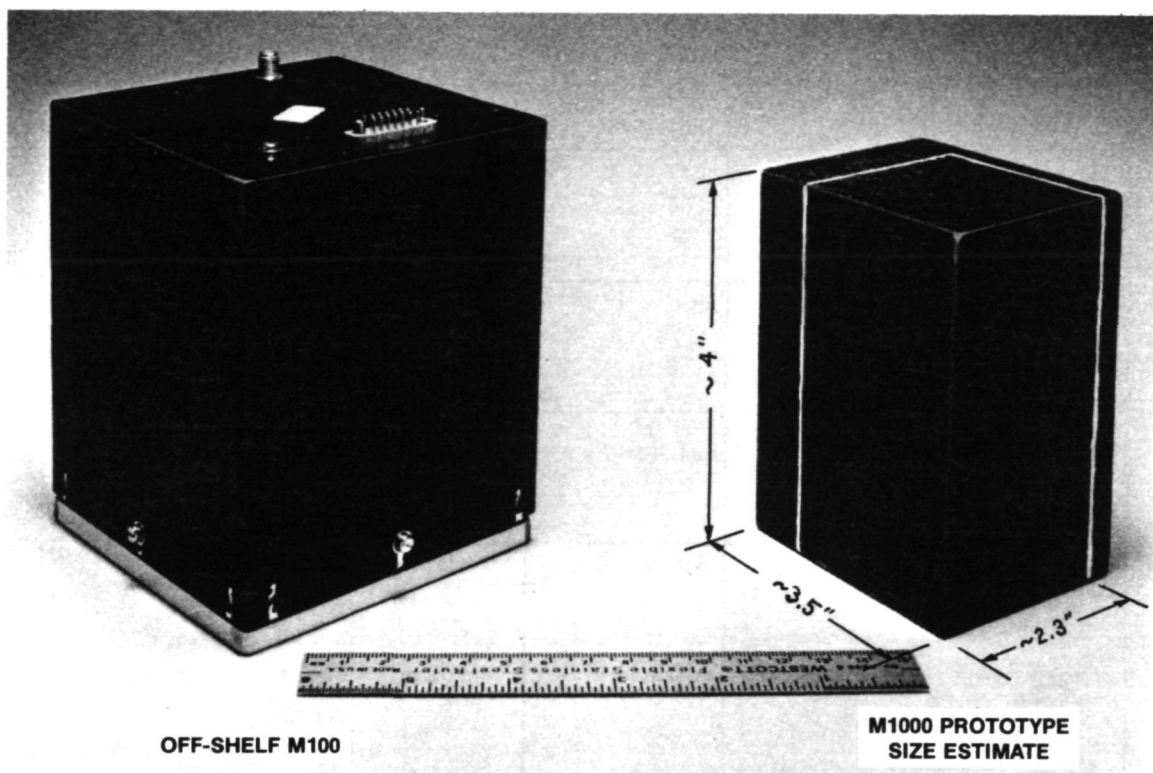

Figure 1. M-100/M-1000 Size Comparison

The error signal is generated by the Physics Package using the method of optical pumping (not discussed here) and appears as a current from the photocell in the Physics Package. When the applied microwave frequency is equal to f_{Rb} , the Rb atoms resonate with the microwave field in the cavity resulting in a decrease (minimum) of the photocell output current. Conventional modulation techniques are used to locate the minimum in the photocell current characteristic (Figure 3). In the M-100, the applied microwave frequency is sine-wave modulated at 127 Hz. This modulation results in an a.c. component of output current from the photocell. When the microwave frequency is different than f_{Rb} , there is a 127 Hz component present whose phase (positive or inverted) depends on whether the microwave frequency lies above or below f_{Rb} . This phase information is used to steer the VCXO in the proper direction to bring the microwave frequency into coincidence with f_{Rb} (at which point the 127 Hz signal is zero). From a practical point of view, the M-100 is considered locked to the atomic resonance when its output frequency is within 1×10^{-9} of exactly 10 MHz.

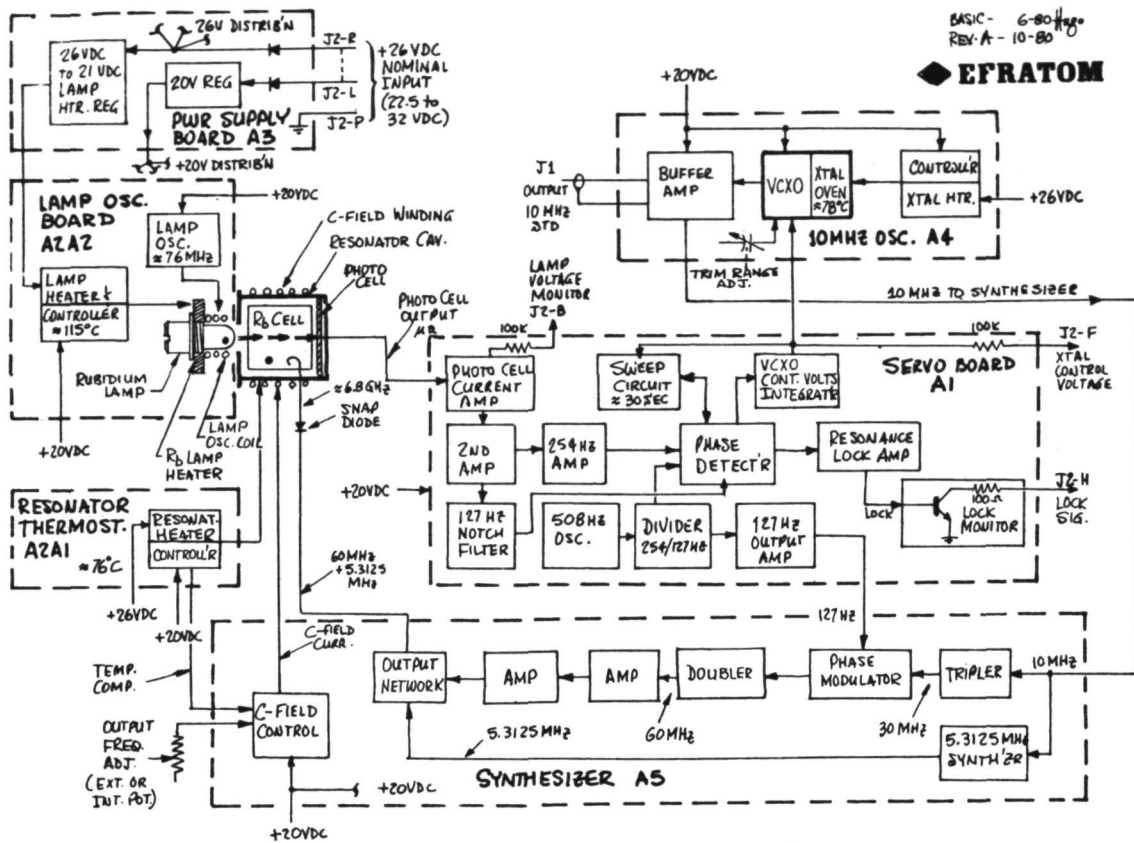

Figure 2. M-100 Functional Block Diagram

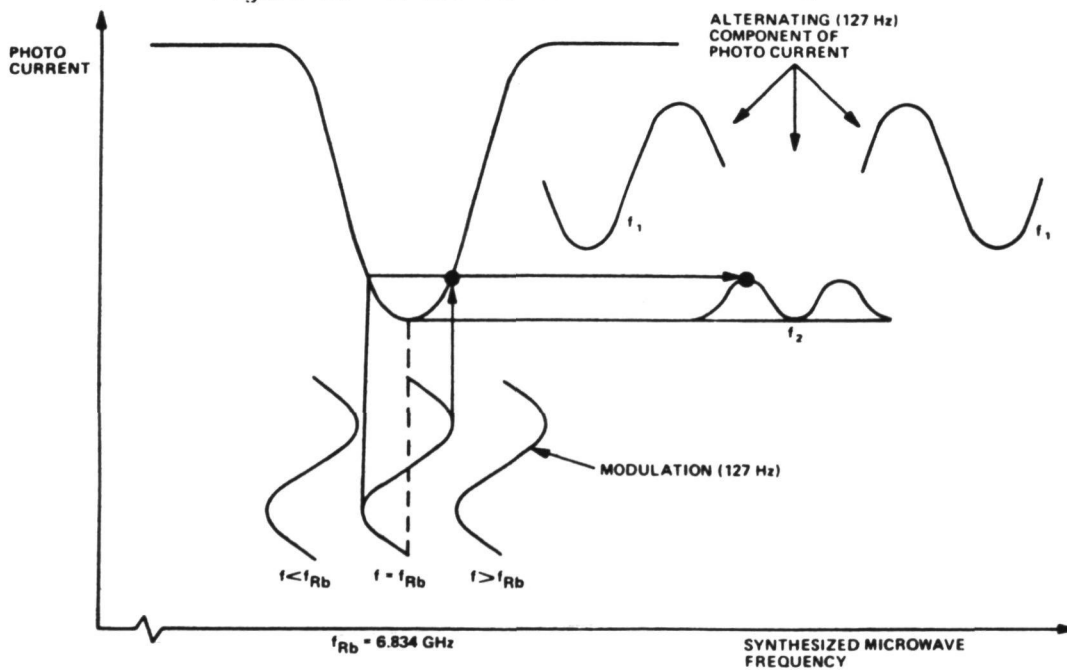

Figure 3. M-100 Modulation Scheme

M-1000 APPROACH

The M-1000 differs from the M-100 Oscillator in the area of the Physics Package, form-factors and some electronic changes. These changes are summarized below but will be discussed in detail later. As noted on the M-1000 Block Diagram of Figure 4, (a) the modulation frequency has been changed from 127 Hz to 254 Hz to reduce sensitivity to the vibration spectrum below 250 Hz, (b) the 40 second sweep during warm-up has been reduced to 6 seconds including a new resonance detection scheme which is among the several things necessary to achieve to 1.5 minute warm-up requirement, (c) a special lamp ignition system to prevent operation in undesired lamp modes which could result from power on-off cycling or external power supply transients, (d) physics changes to allow for MIL-E5400 Class II temperature operation (71° Amb. continuous) including size reduction, (e) an integrated SC Cut VCXO/Rb resonator package with overall lower mass to facilitate the fast warm-up requirement, (f) a Hybrid electronics circuits approach to reduce the overall size of the oscillator.

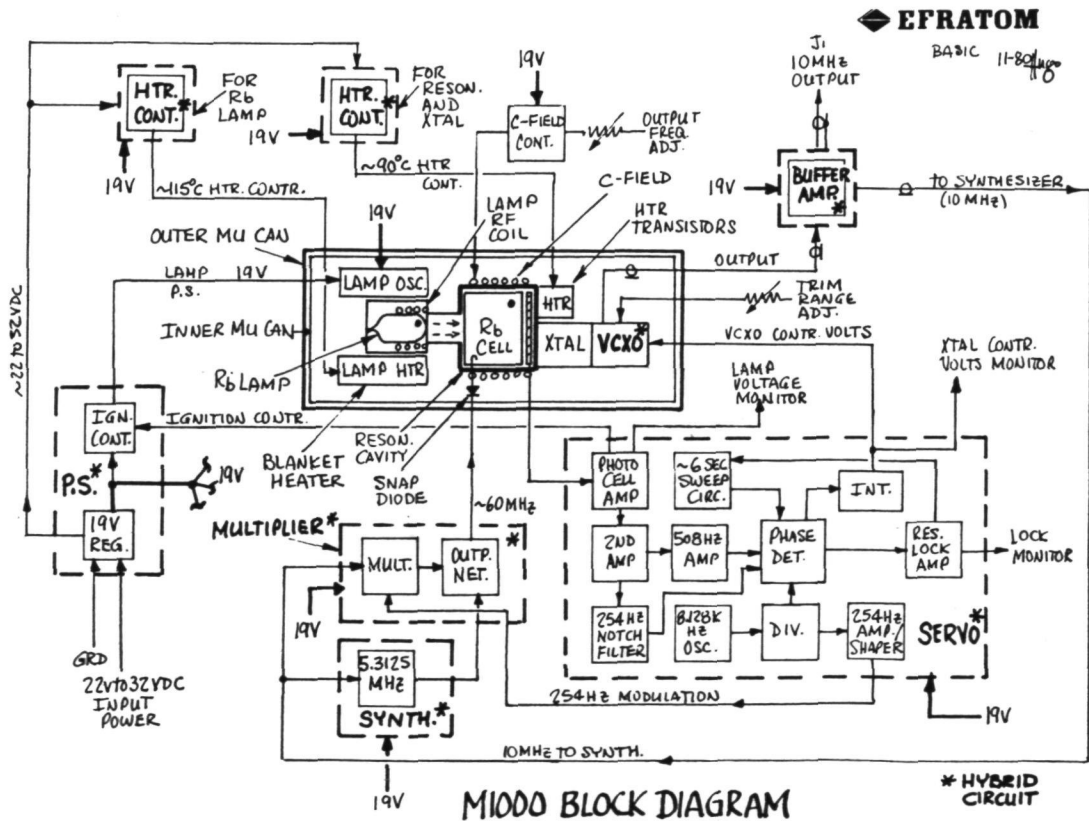

Figure 4. M-1000 Functional Block Diagram

OVERALL MECHANICAL DESIGN

The present design approach will allow for a reduction to half the M-100 volume. The presently planned form-factors are shown in Figure 5. The resonator portion of the Physics Package has been reduced in both size and mass proportions, housing a smaller Rubidium Vapor Cell decreased in length from $1\frac{1}{2}$ in. to $\frac{7}{8}$ in. This has reduced the size of the resonant cavity as illustrated in Figure 6.

The lamp oscillator, Figure 7, does not readily lend itself to Hybridization and thus has been repackaged to make the overall assembly smaller. The major size and mass reduction comes from the use of blanket heaters in place of heating transistors. Since the lamp is not sensitive to varying magnetic fields, the blanket heater approach presents no problem.

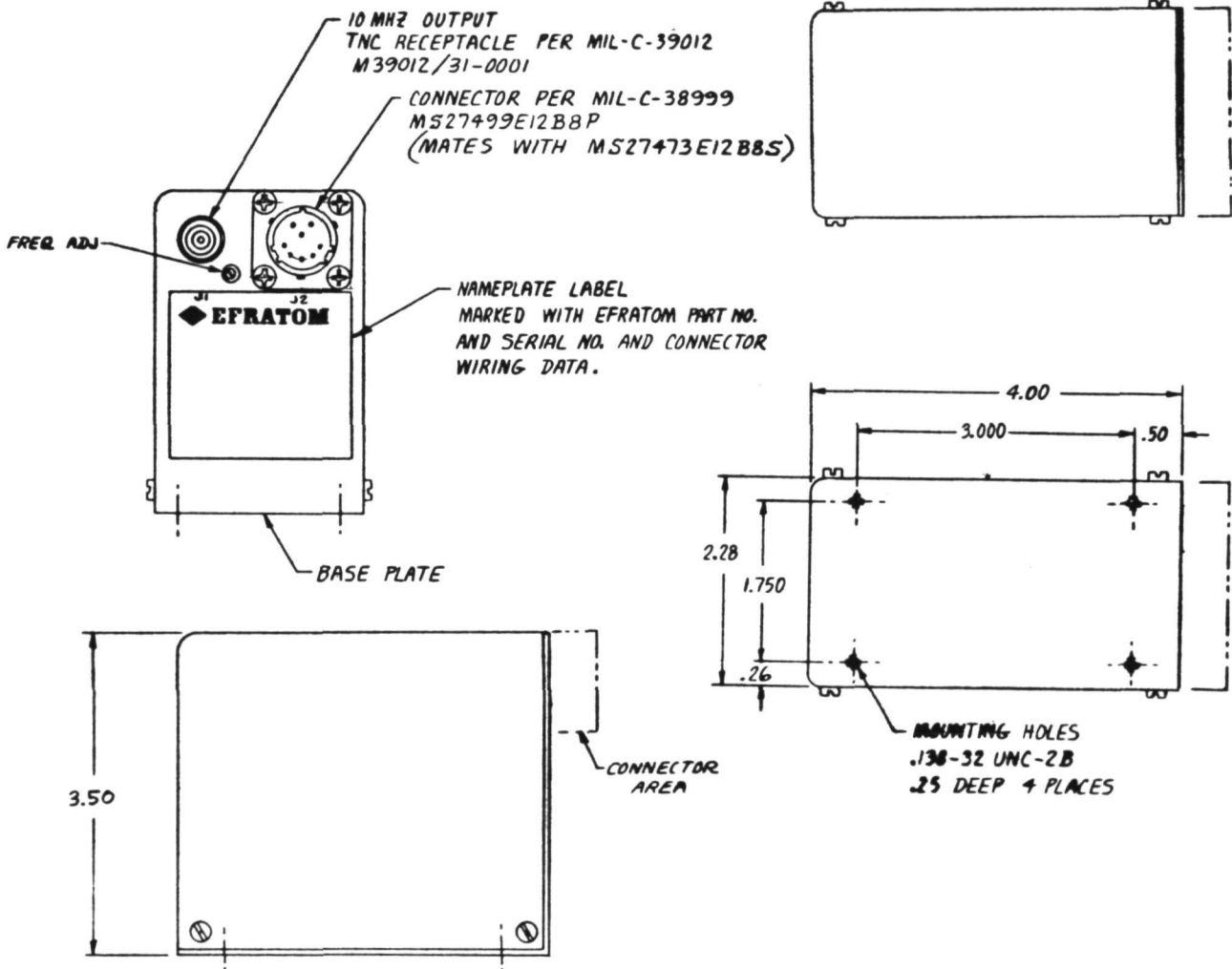

Figure 5. M-1000 Form-Factors

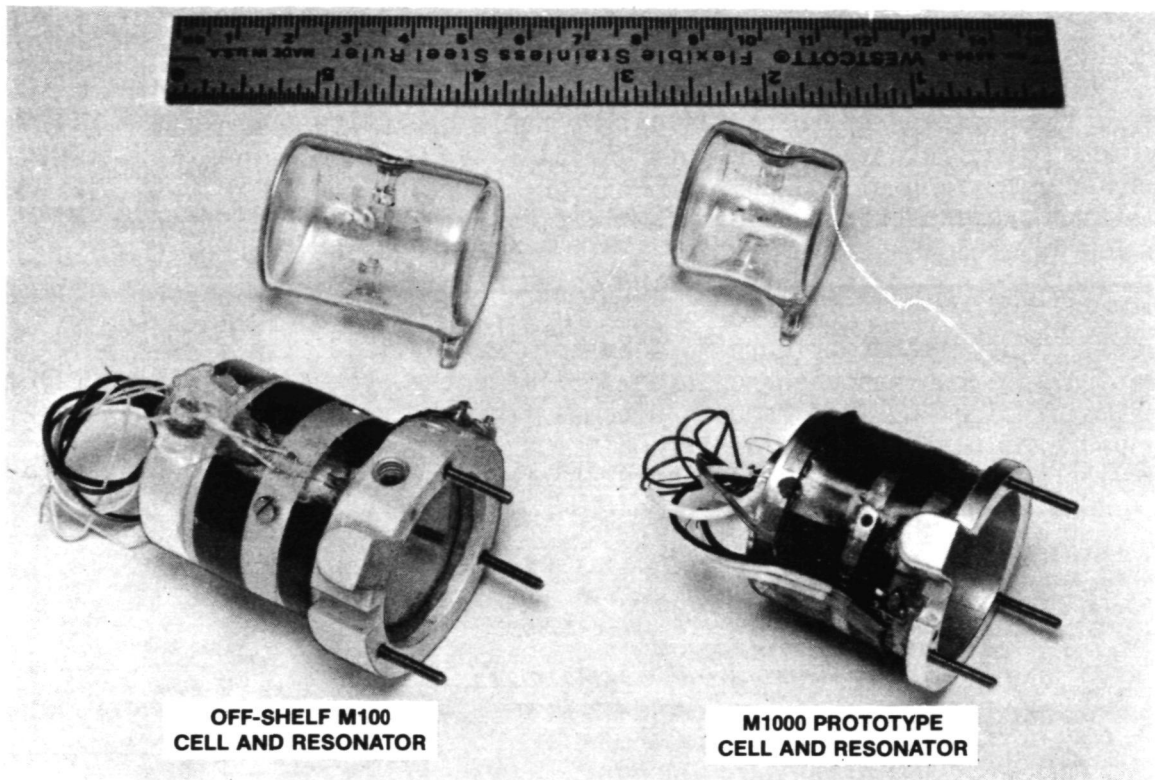

Figure 6. Resonator Comparison

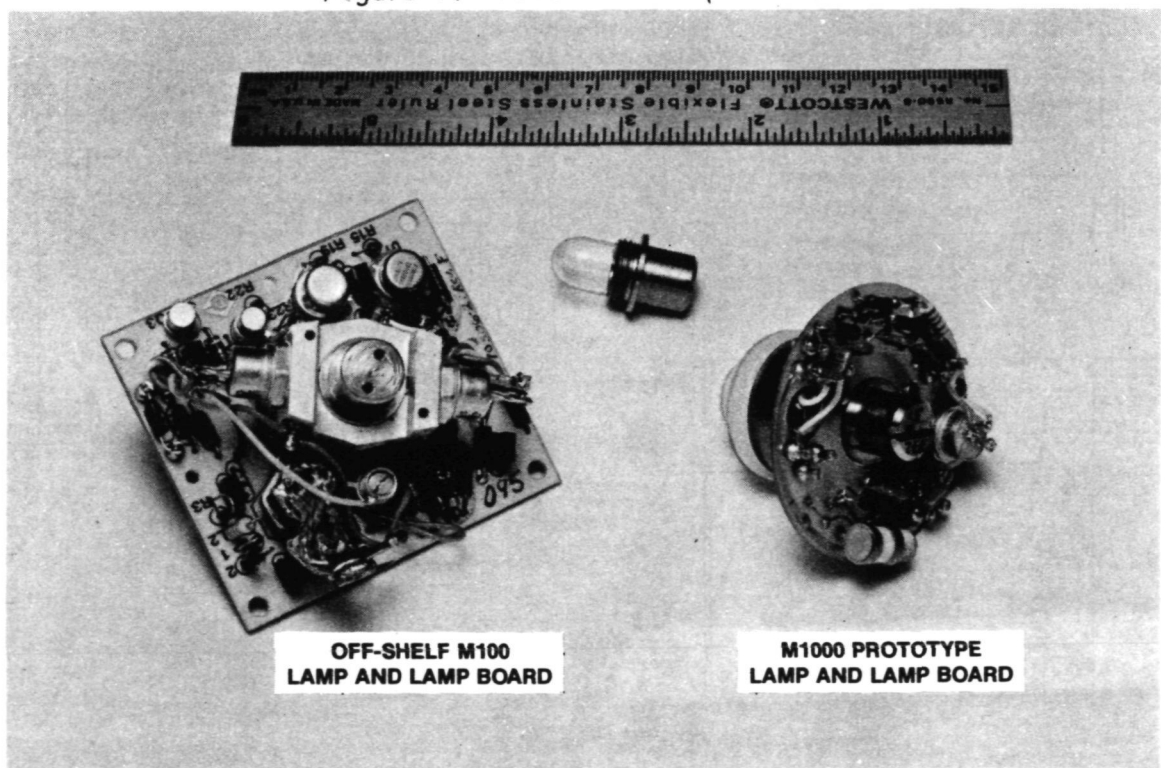

Figure 7. Lamp Board Comparison

These sub-modules integrated into an overall assembly, will resemble the M-1000 Physics Package shown in Figure 8. This integrated assembly will be foamed into an inner Mu-metal housing for reduction of vibration sensitivity with a second outer Mu-metal case again at the Physics Package. This eliminates the need for the outer Mu-metal cover which has been the M-100 design approach and allows for a standard cover which can be sealed to meet salt spray, sand and dust specs. The M-1000 unit thermal design will allow for operation from sea level to hard vacuum space craft applications. All heat will be conducted to the M-1000 mounting baseplate.

The major size reduction comes from our hybrid electronics approach. The Servo Hybrid, before lid-closure, is shown in Figure 9. More than 95% of the electronic parts count will be contained in Hybrid circuits. As shown in Figure 4, the Hybrid circuits are as follows: (a) Servo Hybrid, (b) Power Supply Hybrid, (c) two identical Heater Control Hybrids, (d) the M-100 synthesizer approach has been split into two sections; Multiplier and Synthesizer Hybrids: this allows for more flexibility for future changes in synthesizer approach which may be necessary when mass production quantities are required (2000 or more per year).

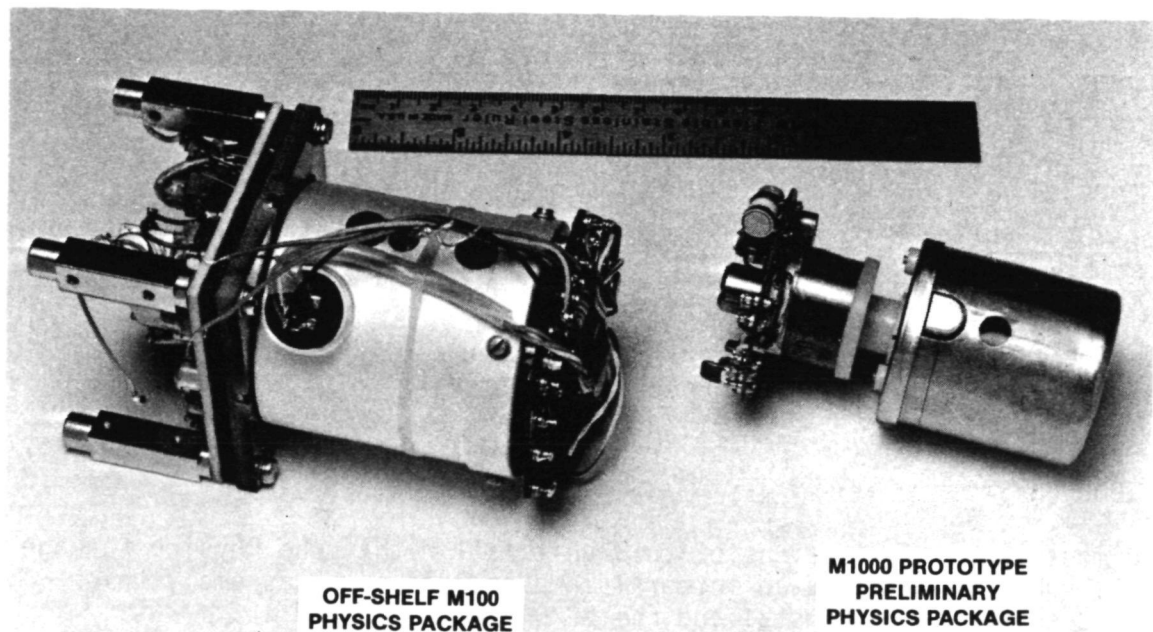

Figure 8. Physics Package Comparison

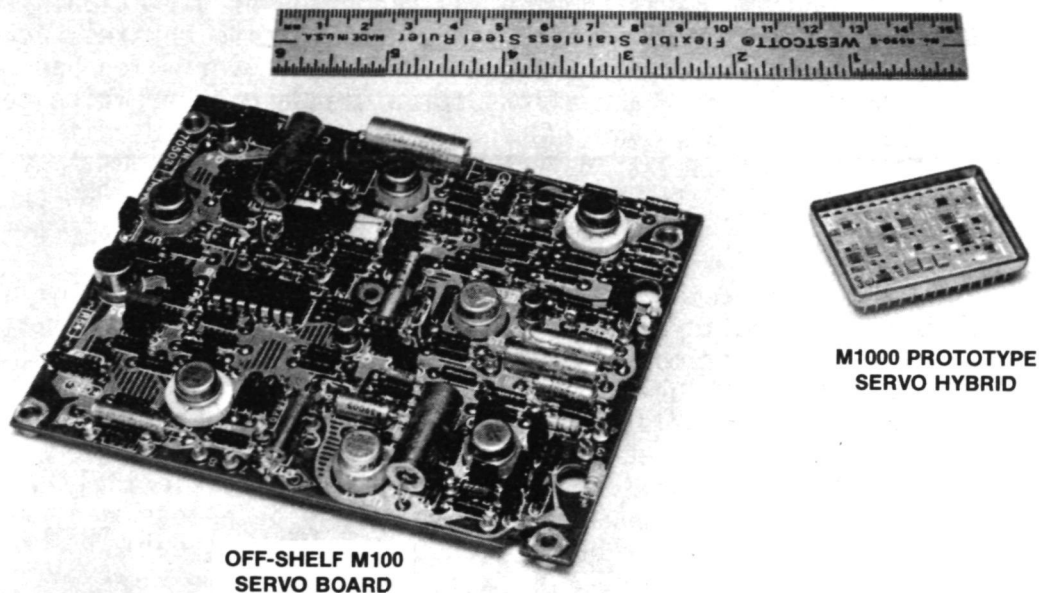

Figure 9. Servo Board Comparison

(e) VCXO Hybrid which will be an integral part of crystal and resonator assembly, and (f) the Buffer Amp Hybrid mounted outside the Physics Package to provide isolation and output drive.

Including eight (8) Hybrids, the M-1000 is expected to have approximately 80 electronic piece parts.

M-1000 PHYSICS

The most innovative designs of this unit fall within the Physics Package area. We have designed an integral lamp and resonator assembly which includes the SC-Cut Crystal and the VCXO Hybrid.

The lamp is our conventional unit but without the usual brass holder. This allows a size reduction. The blanket heater approach allows for rapid heating to the nominal 115°C. The overall temperature of the resonator, which houses a smaller cell, has been raised to approximately 85°C to allow 71° Amb. continuous operation (approximately 80°C base-plate) which meet MIL-E-5400, Class II temperature requirements.

The assembled package will be foamed into the inner Mu-metal can as discussed earlier. VCXO Control Voltage trim range adjustment is accomplished with a varactor diode so that a control pot can be mounted external to the Physics Package.

M-1000 PERFORMANCE CHARACTERISTICS

The most challenging design requirement is the ultra fast warm-up. This task is accomplished by a combination of several concepts discussed earlier. They are: (a) smaller cell/lower mass Physics Package, (b) use of SC-Cut Crystal, (c) use of blanket heater on lamp and cell, (d) special constant power heater control using pulse width modulation, and (e) a fast sweep circuit in the Servo Hybrid.

These factors contribute to the M-1000 warm-up time shown in Figure 10. The off-the-shelf M-100 standard warm-up and fast warm-up options are illustrated for reference. The approximate output frequency that can be expected during warm-up is shown in Figure 11. The frequency will be in the range of $\sim \pm 3 \times 10^{-6}$ until atomic lock. 15 to 20 seconds after the sweep circuit stops, the frequency will be $\sim 5 \times 10^{-10}$. Shortly thereafter, parts in 10^{11} can be expected.

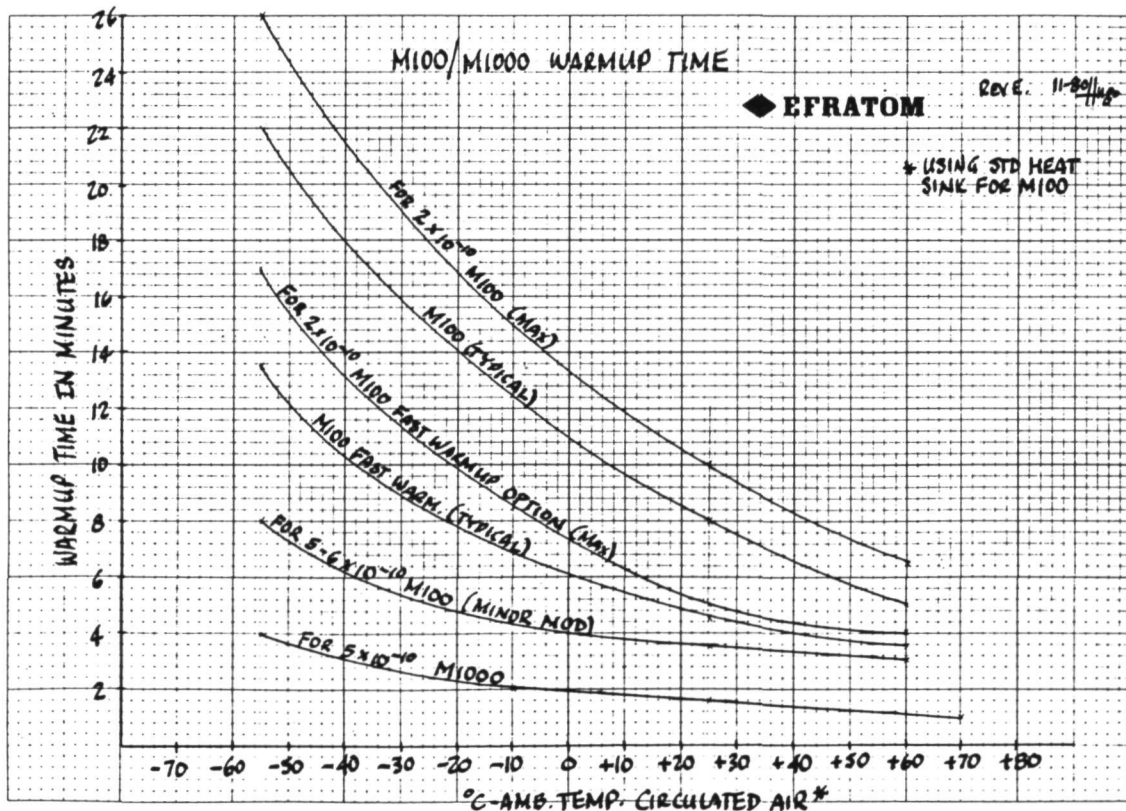

Figure 10. Warm-up Time

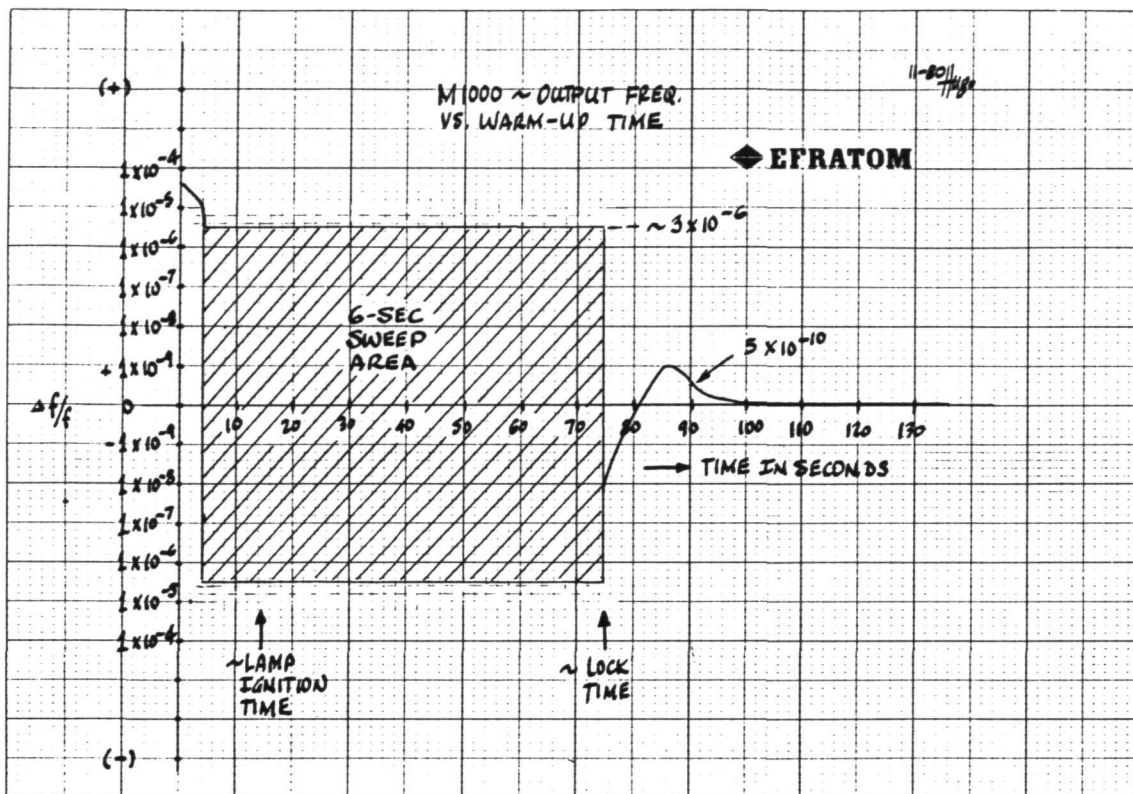

Figure 11. Output Frequency During Warm-up

The M-1000 power dissipation is expected to be 12 watts or less (steady state at 25°C) see Figure 12. A goal of 8 to 10 watts is set for second and third generation units. VCXO performance is expected to be similar to the M-100 spec. The short-term stability is shown in Figure 13 and phase noise in Figure 14. Magnetic field susceptibility is expected to be a factor of 8 to 10 better than M-100 spec and is illustrated in Figure 15.

At present satisfying solutions have been found for all SEETALK requirements and environmental specs with the exception of sine and random vibration performance. These specs are most challenging and extremely difficult to meet. Typical performance under a 1 g sine environment for an M-100 style Physics Package is illustrated in Figure 16. These data are exaggerated, however, since the sweep is extremely slow and tends to amplify the response of the unit at the modulation frequency and it's harmonics.

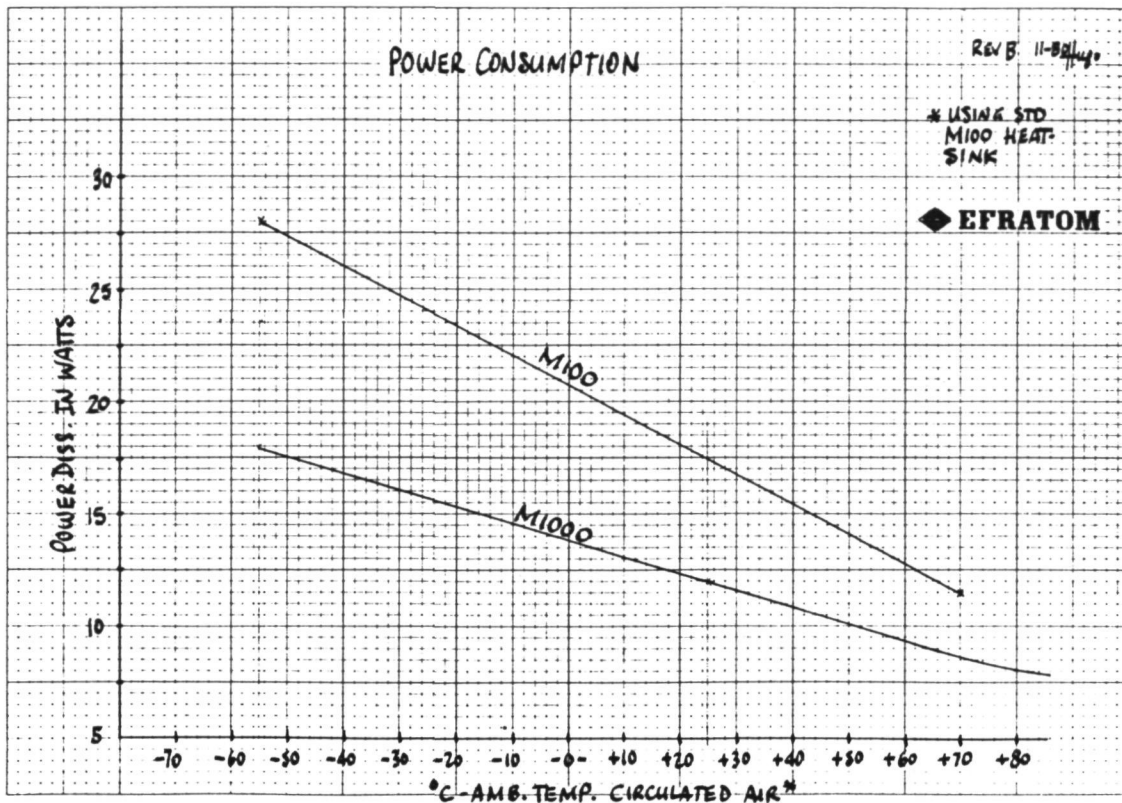

Figure 12. Power Dissipation

Figure 17 shows considerable improvement when the M-100 is modified with the 254 Hz M-1000 servo scheme. This scheme, plus the new M-1000 mechanical approach to the Physics Package should provide a significant improvement over the M-100 data and will certainly make vibration frequencies below 250 Hz less influential. Present M-100 performance at 1 g is parts in 10^8 peak to peak at the modulation frequency; M-1000 performance is expected to be in parts in 10^{10} . Under random vibration, M-100 performance is $< 1 \times 10^{-10}$ at $0.02 \text{ g}^2/\text{Hz}$ at $\tau = 1$ second. This is still considerably higher than the $< 1 \times 10^{-10}$ requirement which is the present SEKTALK spec in a $0.04 \text{ g}^2/\text{Hz}$ environment.

Rb OSCILLATOR "LIFE" CONSIDERATIONS

Useful field life of any electronic equipment or system is generally evaluated in light of hardware peculiarities which will in time render the equipment at a life-limit. This analysis usually excludes random parts failures but is oriented toward wear-out mechanisms.

The M-100/M-1000 oscillator "life" limit revolves around the aging characteristics of the Rubidium Vapor Cell; assuming the Rb lamp has no

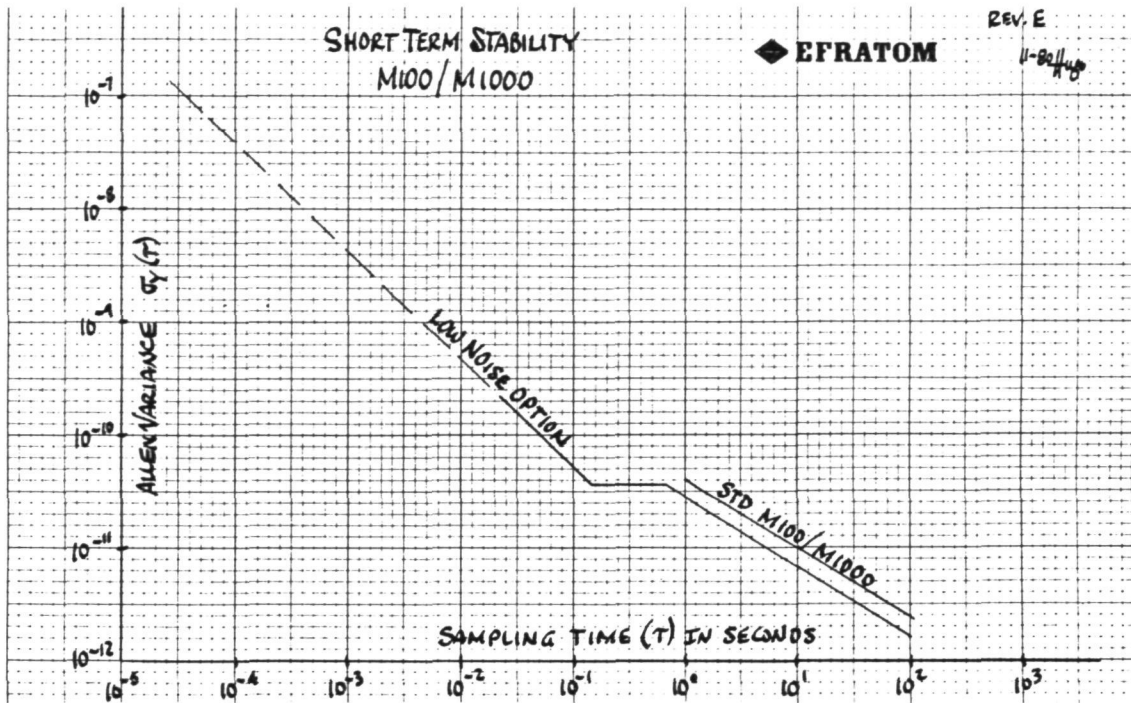

Figure 13. Short Term Stability

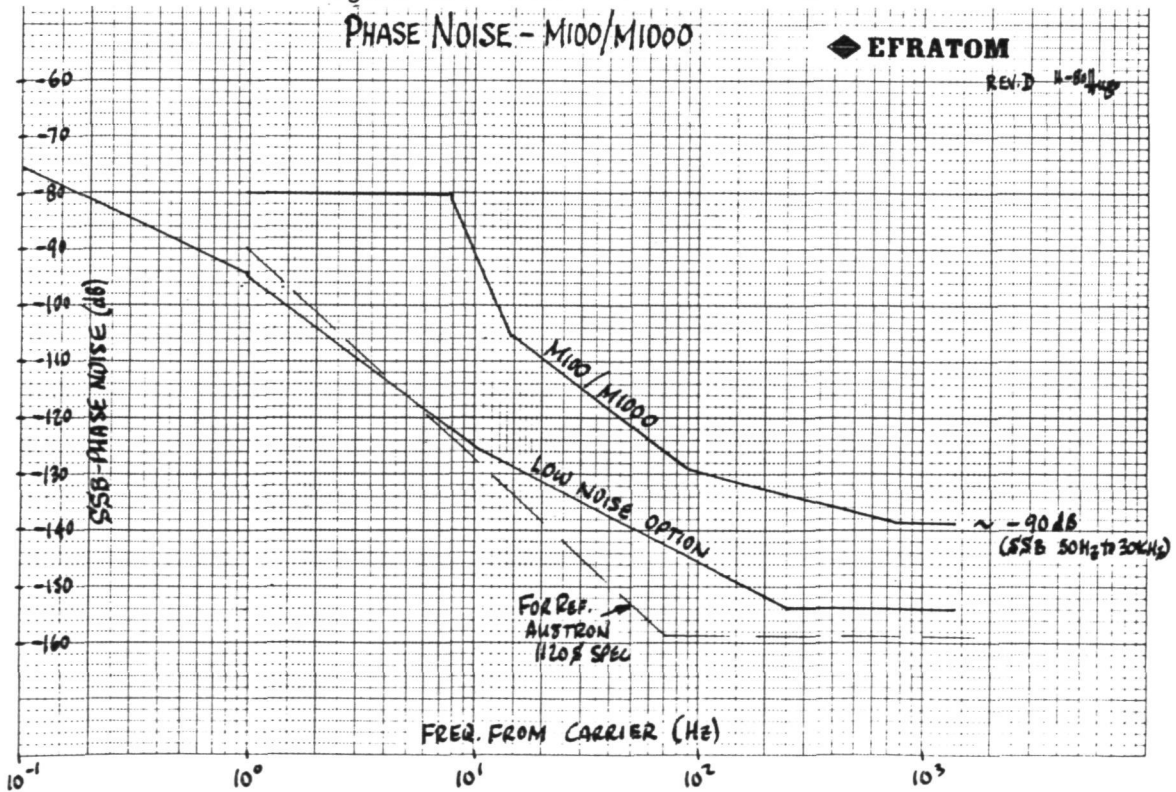
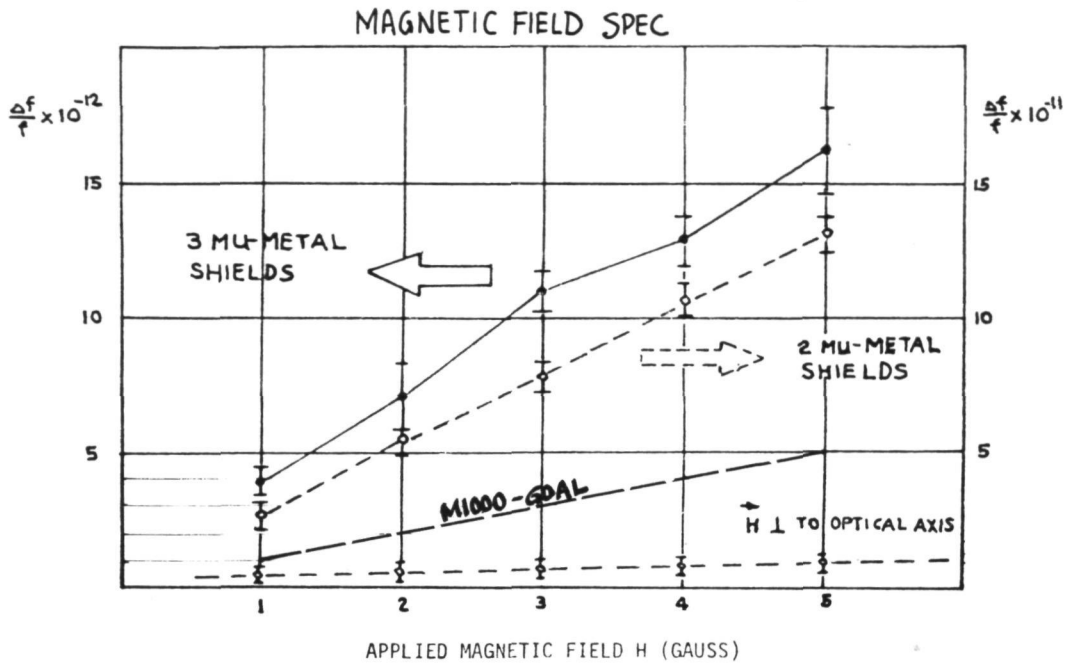

Figure 14. Phase Noise



FRACTIONAL FREQUENCY CHANGE OF THE MODEL FRK-H DUE TO A STATIC MAGNETIC FIELD APPLIED PARALLEL TO THE OPTICAL AXIS

Figure 15. Magnetic Field Susceptibility

systematic wear-out mechanisms, which it does not, if everything is done properly. When the cell is manufactured, it is made with a deliberate negative off-set of approximately $\geq 4 \times 10^{-9}$ which is zeroed by the addition of a magnetic field (C-field). With a C-field trim range of $\pm 1.5 \times 10^{-9}$, the oscillator will allow normal adjustments as long as the frequency of the cell has not aged past the $\Delta f/f$ equivalent of (+) 1.5×10^{-9} of 10 MHz.

As can be seen in Figure 18, the typical oscillator will begin to age at a rate of (-) $3 \times 10^{-11}/\text{mo}$ for about 5 to 6 months while steadily improving to $\leq 1 \times 10^{-11}/\text{mo}$. After the initial (-) aging, the oscillator may drift (+) or continue (-). Long-term aging data show that the oscillator will not always drift in the same direction. The data also show, however, that the typical oscillator, while operating, continues to improve, with the monthly drift tending to decrease in magnitude. Aging improvements have also been observed for stored units with the extent of the improvement depending on the storage temperature. For illustration purposes, Figure 18 shows three curves. Curve (a) is for a typical oscillator that, after 5 to 6 months, continues to age always negative (best case). In this case, the frequency off-set that accumulates can be cancelled by increasing the magnetic field (C-field current). Under these conditions, the normal C-field trim range of $\pm 1.5 \times 10^{-9}$ will have been reached in

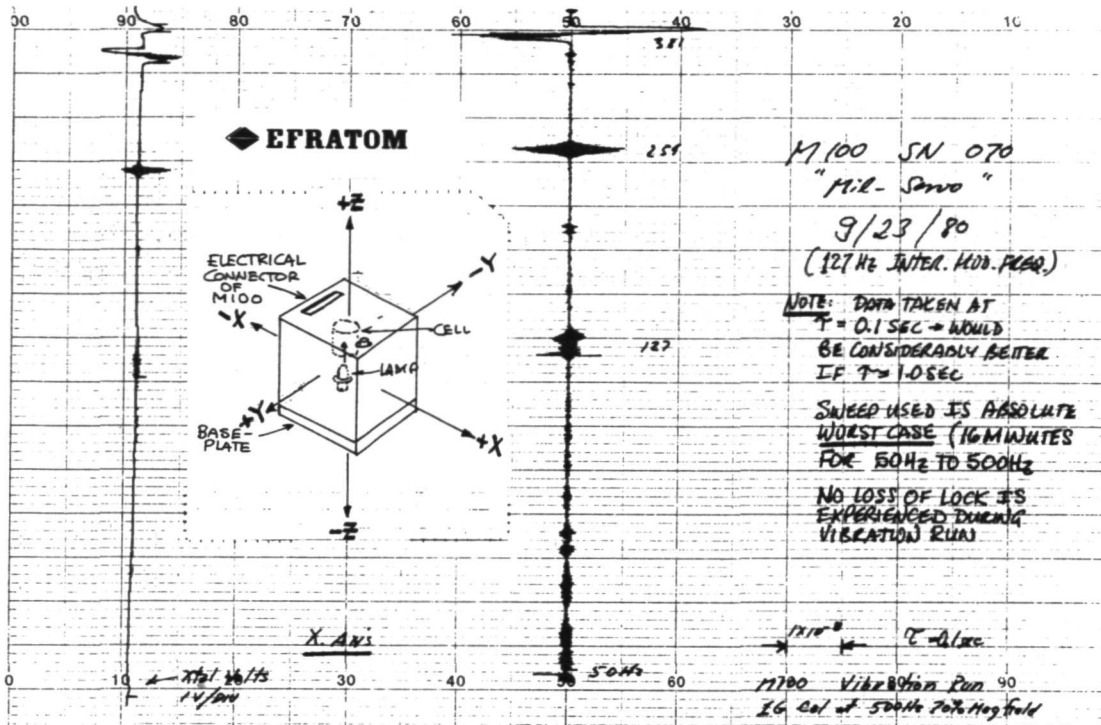

Figure 16. Sine Vibration Data - 1 g
(127 Hz Modulation)

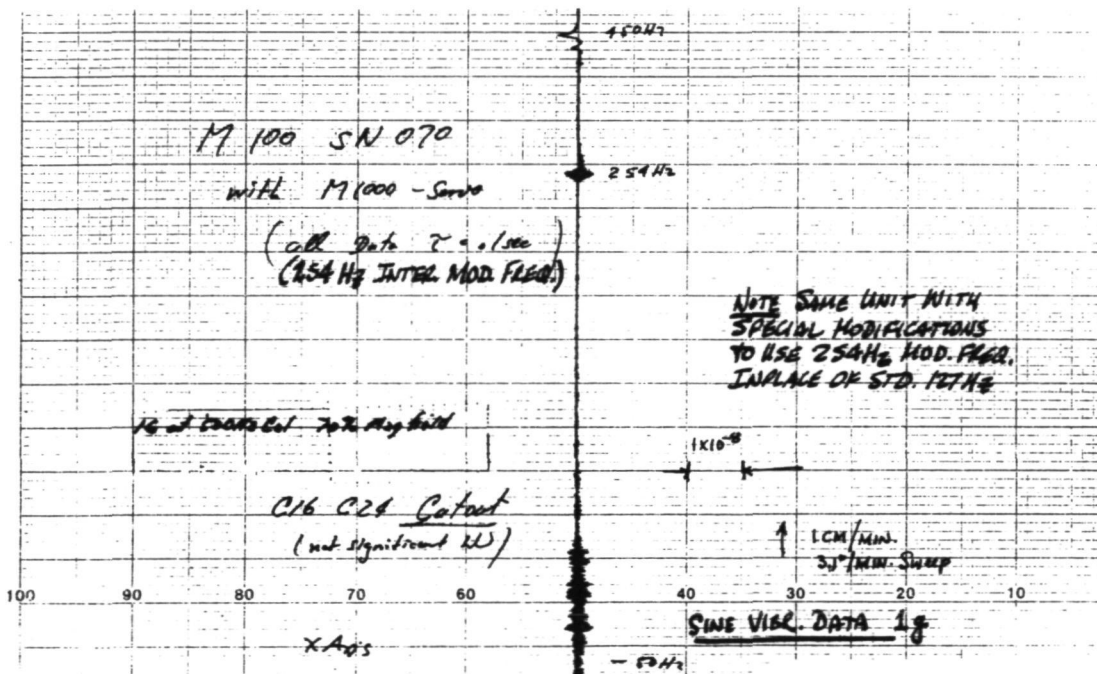

Figure 17. Sine Vibration Data - 1 g
(254 Hz Modulation)

~ 11 years. In practice, magnetic field can be added at that time but at a degradation of unit magnetic field spec; doubling the C-field current approximately doubles the external field sensitivity. For example, if we allow a degradation of the shielding factor of ~ 50%, the end of the useful life will be reached after ~ 80 years.

Curve (b) applies for the case of an oscillator that, after the first 5 to 6 months, ages continually positive. Here the $\sim 3 \times 10^{-9}$ point is reached in approximately 35 years. Since the positive aging cell requires a reduction in magnetic field, the cell at this point is for practical purposes at zero magnetic field. As aging continues past this point, the oscillator will still operate in a completely stable fashion (according to spec), but it will no longer be possible to zero the offset that will gradually accumulate.

The third case, curve (c), is absolutely the worst case and as far as we know, has never occurred. In this phase, the oscillator ages continually positive at the constant rate of $3 \times 10^{-11}/\text{mo}$, reaching zero frequency off-set at zero magnetic field after approximately 11 years.

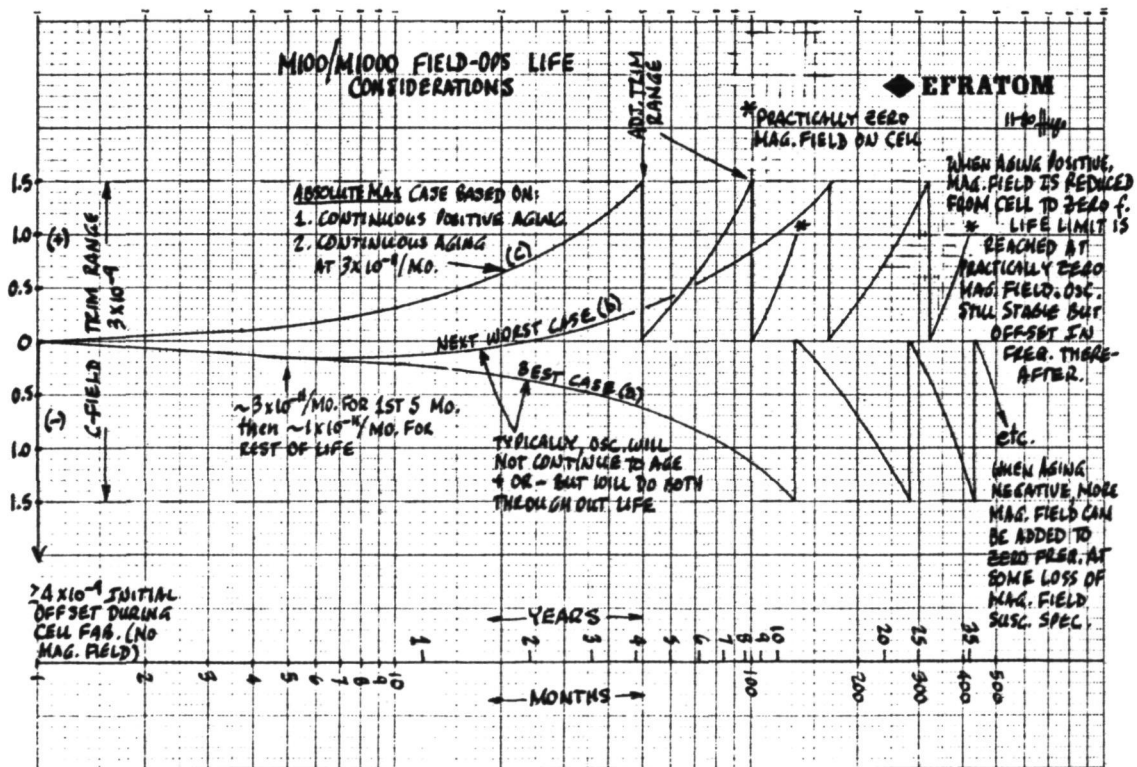

Figure 18. Oscillator Life

MISSION PROFILE

Figure 19 illustrates an arbitrary mission profile and resultant oscillator performance. The concept for a precision timing system for tactical aircraft, revolves around the ability to have an oscillator within parts in 10^{10} , 1.5 minutes after engine start (assuming no battery power is available prior to that time). This ability provides ample time for a timing-sync (possibly RF linked) before aircraft is very far from its origin, minimizing RF link propagation delay errors. Due to the accuracy and retrace ability of the Rb oscillator, frequency sync would not be necessary prior to a mission as long as a periodic calibration plan is in effect. The 1.5 minute warm-up capability would appear to greatly simplify the tactical system. No battery power is required on the aircraft and no external warm-up scheme is needed.

Factors which have the most significant effect on oscillator time error are temperature changes and vibration. The least impact are voltage variations, magnetic field changes, and acceleration. Oscillator aging

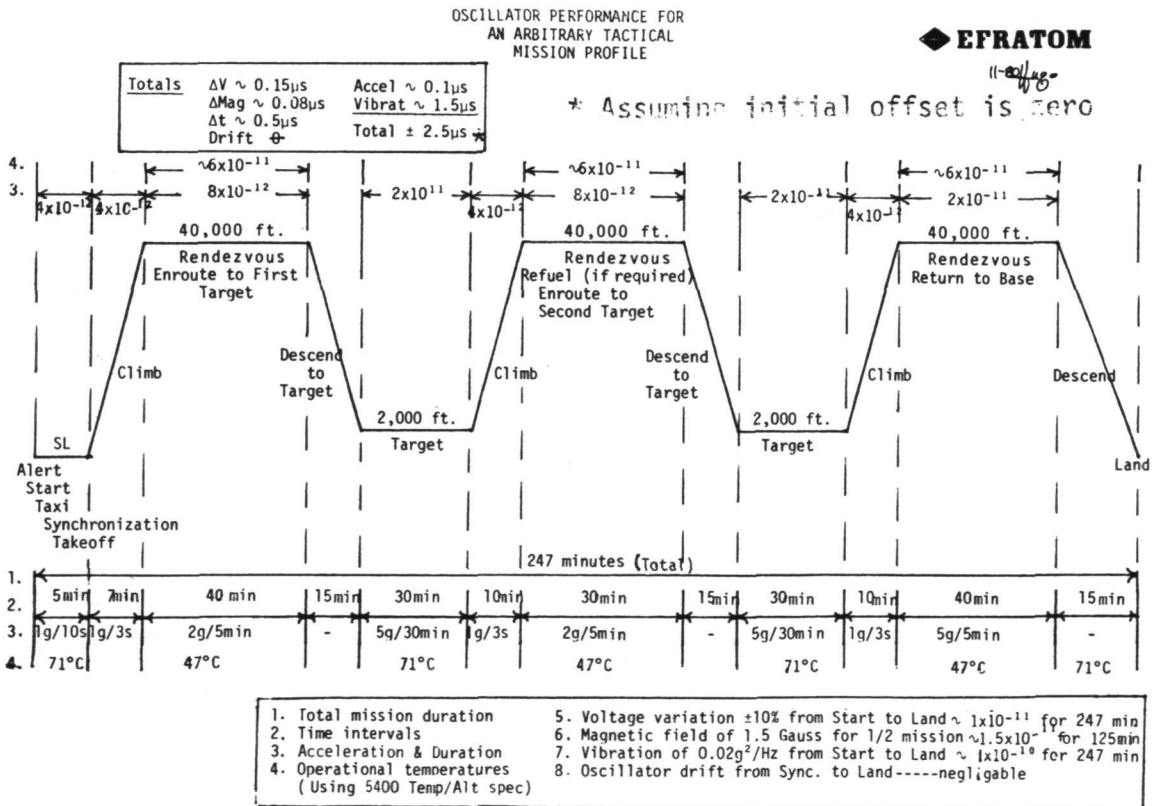

Figure 19. Typical Mission Profile

or drift is negligible. Since the oscillator is used as a clock, many of the environments such as magnetics and vibration should have a somewhat cancelling effect with only residuals influencing the time error.

Preliminary data has been received from Edwards Air Force Base for flight tests of similar mission profiles using shock-mounted EFRATOM commercial FRK-L units. The data indicates an accumulated time error scatter of ~ 1.3 to $12.1 \mu\text{s}$. Flight duration of these tests varied between ~ 7 to 11 hours.

CONCLUSION

We are proceeding with full speed to complete this new M-1000 development in mid 1981 to meet the SEEKTALK schedule. Several prototype units will be delivered to RADC at that time for test and evaluation. We believe that the 1.5 minute warm-up atomic oscillator will revolutionize the tactical warfare theater and will greatly improve the present-day military communication and navigation system capabilities.

The major portion of the Hybrid vendor costs for the initial prototype units is being funded by RADC.

SUMMARY OF ENVIRONMENTAL PERFORMANCE

0 VIBRATION^Δ

	<u>M100</u>	<u>M1000</u>
(REALISTIC) - 0.02g ² /Hz, 20-50Hz, SLOPING to 0.001g ² /Hz at 500 Hz (~ 1.6g rms)	1 x 10 ⁻¹⁰ , τ = 1 sec* AT-CUT XTAL 0.2 μsec/HR*	BETTER; WILL USE SC-CUT XTAL < 0.2 μsec/HR
(SEEKTALK) - 0.04g ² /Hz ~ FLAT 1.5 - 500Hz (~ 4.4g rms)	PARTS 10 ⁹ , τ = 1 sec AT-CUT XTAL	SHOULD BE MUCH BETTER:

*
5 μsec/HR

(SEEK-TALK SPEC IS
1 x 10⁻¹⁰)

0 MAGNETICS - 180° TURN (MAX EARTH FIELD)	SPEC 3 to 5 x 10 ⁻¹¹ ACTUAL ~ 1 x 10 ⁻¹¹	PARTS IN 10 ¹²
0 ALTITUDE - S.L. to 40K ft (NEGLECTING TEMP Δ)	(-) ~ 7 x 10 ⁻¹¹	SAME; POSSIBLY BETTER
0 TEMPERATURE - (RAISING Δ +25°C)	(+) ~ 1 x 10 ⁻¹⁰	(+) ~ 6 x 10 ⁻¹¹
0 ACCELERATION - (WORST AXIS)	(-) ~ 4 x 10 ⁻¹² /g	BETTER

ΔNOTE: Edwards AFB - Modified Thunderbird Tests
- Shock Mounted Commercial FRK
- 1.3 μs to ~ 12.1 μs for Test Durations
- 7 to 11 HRS.

*12-2-80 TEST DATA ON
#018, #111 M100 UNIT

QUESTIONS AND ANSWERS

MR. SAMUAL WARD, Jet Propulsion Laboratory

Have you considered whether or not the so-called vibration or gravitational effects on the unit may be induced currents that are getting into the XVCO loop?

MR. FRUHAUF:

You mean, on the vibration table?

MR. WARD:

Correct.

MR. FRAUHAUF:

Yes, we have checked very carefully the magnetic fields that are set up on the vibration head, and we have got that pretty well nailed down.

MR. WARD:

Was the power supply -- how much of the unit was being shaken?

MR. FRUHAUF:

In these particular tests?

MR. WARD:

Yes.

MR. FRAUHAUF:

The entire unit.

MR. WARD:

Shielding and all.

MR. FRUHAUF:

Right. We have been sensitive to that area, so we characterized the table very carefully before we draw a lot of conclusions from the data.

MR. WARD:

It looks suspicious because the power goes up as the vibration frequency goes up.

MR. FRUHAUF:

What goes up, please?

MR. WARD:

The power -- the effect -- how much it is being pulled off frequency, which appears to me power related.

Normally, as you shake it faster, that should go down.

MR. FRAUHAUF:

It is primarily related to resonances in the system. It is definitely not the magnetic field from the shake table.