

## N O T I C E

THIS DOCUMENT HAS BEEN REPRODUCED FROM  
MICROFICHE. ALTHOUGH IT IS RECOGNIZED THAT  
CERTAIN PORTIONS ARE ILLEGIBLE, IT IS BEING RELEASED  
IN THE INTEREST OF MAKING AVAILABLE AS MUCH  
INFORMATION AS POSSIBLE

NASA CR-166699

# SATELLITE-AIDED COASTAL ZONE MONITORING AND VESSEL TRAFFIC SYSTEM

(NASA-CR-166699) SATELLITE-AIDED COASTAL  
ZONE MONITORING AND VESSEL TRAFFIC SYSTEM  
Final Report (Baker Development Corp.) 92 p  
HC A05/MF A01 CSCL 17G

N81-28072

Unclass  
31113

G3/04

**James L. Baker**  
**Baker Development Corporation**  
**Sherwood Forest, Md. 21405**

**June 1981**  
**Final Report**

Prepared for  
**GODDARD SPACE FLIGHT CENTER**



**FINAL REPORT**

**SATELLITE-AIDED**

**COASTAL ZONE MONITORING**

**AND**

**VESSEL TRAFFIC SYSTEM**

**Contract #NAS 5-25105**

**Baker Development Corporation**

SATELLITE-AIDED  
COASTAL ZONE MONITORING AND VESSEL TRAFFIC SYSTEM

TABLE OF CONTENTS

	<u>PAGE</u>
1.0 <u>INTRODUCTION</u> .....	1
1.1 BACKGROUND.....	1
1.2 OBJECTIVES.....	3
1.3 JUSTIFICATION.....	4
1.4 VESSEL TRAFFIC SYSTEMS.....	5
1.5 METEOR TRAIL COMMUNICATIONS LINK.....	7
2.0 <u>SYSTEM DESCRIPTION</u> .....	8
2.1 GENERAL.....	8
2.2 OPERATIONS DESCRIPTION.....	10
2.3 SATELLITE COMMUNICATIONS LINK.....	12
2.4 TEST VEHICLE.....	13
2.5 ON-BOARD SYSTEM.....	14
2.5.1 <u>Antennas</u> .....	14
2.5.2 <u>Power Supply</u> .....	15
2.5.3 <u>Transceiver</u> .....	15
2.5.4 <u>Preamplifier</u> .....	16
2.5.5 <u>RF Power Amplifier</u> .....	16
2.5.6 <u>Communications Terminal</u> .....	18
2.5.7 <u>Communications Central Processor (CCP)</u> .....	18
2.5.8 <u>LORAN-C Receiver</u> .....	24
2.5.9 <u>LORAN-C/PCM-CCP Interface</u> .....	26
2.6 COMMUNICATIONS LINKS.....	35
2.7 DISPLAY AND CONTROL SYSTEM.....	35

	<u>PAGE</u>
3.0 <u>PRELIMINARY TESTS</u> .....	38
4.0 <u>TESTS ABOARD SLOOP</u> .....	40
5.0 <u>EXPERIMENTS</u> .....	43
5.1 TEST AREA.....	43
5.5.1 <u>June 1979 Test</u> .....	44
5.5.2 <u>August 1979 Test</u> .....	45
6.0 <u>LOWER CHESAPEAKE BAY FINAL DEMONSTRATION</u> .....	47
7.0 <u>RESULTS OF DEMONSTRATIONS</u> .....	52
7.1 LORAN-C NAVIGATION SYSTEM.....	52
7.2 ROLL CALL TECHNIQUE.....	52
7.3 DISPLAY SYSTEM.....	53
7.4 COMMUNICATIONS.....	53
8.0 <u>CONCLUSIONS</u> .....	53
8.1 SYSTEM ADVANTAGES.....	53
8.2 MULTIUSE CAPABILITIES OF SYSTEM.....	55
REFERENCES.....	57

## ILLUSTRATIONS

<u>FIGURE</u>	<u>TITLE</u>	<u>PAGE</u>
1	Coastal Zone Monitoring System Functional Block Diagram..	10
2	ATS 1 and 3 Coverage Areas.....	12
3	Motor Sailer "Sunshine".....	14
4	Transceiver and Preamplifier.....	16
5	Close-up of Preamplifier.....	17
6	RF Power Amplifier.....	17
7	Communications Terminal in Operation.....	19
8	Communications Central Processor System Functional Block Diagram.....	20
9	Communications Central Processor System.....	21
10	LORAN-C Micrologic-1000 Navigator.....	25
11	Electrical Interface Module.....	27
12	Electrical Interface Module Mounted in ML-1000 Navigator.	27
13	LORAN-C Receiver Subsystem.....	28
14	Schematic Diagram of LORAN-C/PCM-CCP Interface Module....	32
15	Timing Diagram.....	34
16	Communication Links for Tests and Demonstration of Vessel Data and Position.....	36
17	Control Center Chart Generation and Display Processing...	38
18	Video Display of Test Area - Zoom Level 1.....	48
19	Video Display of Test Area - Zoom Level 2.....	40
20	Video Display of Test Area - Zoom Level 4.....	50
21	Typical Teletype Printout.....	51

ILLUSTRATIONS (Continued)

<u>FIGURE</u>	<u>TITLE</u>	<u>PAGE</u>
<u>APPENDIX A</u>		
A-1	Functional Overview of Ship Tracking and Display System.	A3
A-2	Ship Survey System Overview.....	A5
A-3	Map Generation System (PDP-11/70 Computer).....	A8
A-4	Display Processing Subsystem (PDP-11/45 Computer).....	A10
A-5	Software System.....	A16
A-6	Typical Logical Record.....	A19
<u>APPENDIX B</u>		
B-1	Typical Data Obtained During Experiments of June 9-16, 1979.....	B3
B-2	Typical Data Obtained during Experiments of July 25- August 3, 1979.....	B4

## FINAL REPORT

### SATELLITE-AIDED COASTAL ZONE MONITORING AND VESSEL TRAFFIC SYSTEM

by  
James L. Baker  
ATS-3 Experimenter

#### 1.0 INTRODUCTION

##### 1.1 BACKGROUND

The need for improved technology and procedures to reduce the number of collisions and groundings of major commercial vessels, especially oil tankers, can hardly be overstated. Tankers continue to collide with one another or ram drilling or production platforms in coastal waters.

To this end, the United States Coast Guard (USCG) has taken major steps to alleviate the problem under the authority provided them by Public Law 94-265, the Fishery Conservation and Management Act of 1976, and Public Law 94-474, the Port and Tanker Safety Act of 1978. These acts extend the Coast Guard's responsibility in fisheries protection and management and in safety of vessels in the 321.8 kilometer (200-mile) coastal zone. Many techniques for improving the hull integrity, electronic navigation, communications, vessel traffic systems and radar equipment have been promulgated by the USCG.

The Coast Guard and Maritime Administration have continuing programs to study and implement methods of assisting in the safe navigation of coastal and inland waterways<sup>1</sup>. LORAN-C chains are constantly being improved, and provide now essentially complete coverage of the United



States coastal zones and island possessions<sup>1</sup>. Existing LORAN-C stations signal transmissions undergo periodic calibration in the more critical areas. Together with technological advancements, this makes the system increasingly more accurate and reliable for position fixing. The resultant system accuracy and the availability of commercial receivers with direct computation and readouts of latitude and longitude are the main reasons for using the LORAN-C navigation system for developing it as the basis of a satellite-aided offshore vessel traffic system.

In 1979 Rear Admiral N. C. Venzke, Chief of Operations, US Coast Guard, requested the National Aeronautics and Space Administration (NASA) to assist in the development of space-related techniques to aid in the location and identification of vessels within the 321.8 km (200 n. mile) US Coastal Zone.

The USCG, National Oceanic and Atmospheric Administration (NOAA), California Coastal Commission, Santa Barbara Board of Supervisors and California Energy Commission have been deeply concerned with the past vessel collisions, oil spills, and the increasing potential problem of oil spills of the California Coast. A Memorandum of Understanding between the State of California and NASA was signed on November 22, 1977. Under the terms of this agreement NASA is to provide technological assistance to the public needs, including, specifically, "ship location monitoring and energy related activities." A cost-sharing contract was signed July 17, 1978 between the NASA/Goddard Space Flight Center (GSFC) and the Baker Development Corporation to develop and demonstrate

equipment necessary to automatically interrogate ships, retransmit, and display LORAN-C position at a "control center" via satellite relay of communications. Automatic interrogation and transmission of vessel's prearrival messages via satellite was also a requirement of this project.

The hardware and software was developed to demonstrate the feasibility of the concept in a small test area at the mouth of the Chesapeake Bay. A 12.7 meter (45-foot) sailing yacht was used to simulate a large commercial vessel such as a tanker. New system-required components were developed and integrated later with commercially available equipment. Experiments were conducted through the summer of 1979 and final demonstrations using the ATS-3 satellite were completed in October 1979 in the lower Chesapeake Bay.

It is clear that satellite-aided systems can be of substantial benefit, but the systems must be designed to complement close-in traffic advisory systems, such as those using radar or line-of-sight VHF retransmission of LORAN-C data.

## 1.2 OBJECTIVES

The objectives of this project were to develop and test the necessary equipment to demonstrate the feasibility of a system using a satellite communication link to:

1. extend the range of vessel traffic systems using automatic interrogation and response

2. provide automatic interrogation and response of text messages from vessels within the 321.8 kilometer (200 n. mile) coastal zone of the United States

3. provide warning from the control center to the vessel if danger is imminent and recommend course changes if necessary to avoid damage.

### 1.3 JUSTIFICATION

The following statistics, published by the USCG in 1978, indicate the magnitude of the problem:

Vessels involved in collisions crossing, meeting, and overtaking...	894
Vessels involved in collisions in fog.....	2
Vessels involved in collisions with piers and bridges.....	1244
Vessels involved in all other collisions.....	585
Vessels involved in grounding with damage.....	700
Vessels involved in grounding without damage.....	808

Further examination of the statistics shows that 91.4% of the collisions were due to "failure on part of other vessel or person" while less than 1% were due to adverse weather and 3% to equipment failure. During this period 179 persons were killed and 119 injured. In addition, spills caused by collisions are becoming a major environmental problem, as shown below:

US Waters*	
Spills over 100,000 Gallons	
<u>Year</u>	<u>Gallons</u>
1974	3,338,350
1975	11,562,636
1976	11,067,356
1977	10,435,000
1978	8,953,881
1979	12,394,000

\*Data provided by the US Coast Guard

These statistics do not include other categories or casualties such as collision with docks, anchorings, foundering, capsizing, floodings, heavy weather damage, cargo damage, or material failures. Since most collisions and groundings result from personnel errors, the assistance of a pictorial display of ship traffic, aided by computers and experts in rules-of-the-road, could reduce the number of accidents.

A prime advantage of the demonstrated system is its ability to identify potential collision courses in sufficient time to provide ample warning. This vessel traffic system (VTS) is capable not only of preventing ship-to-ship collisions, but also of alerting the ship's personnel in relation to location of bridges, drilling platforms, abutments, shoals, etc.

According to the General Accounting Office<sup>2</sup> the number of serious collisions in 1977 was 2330 with a loss of 89 million dollars. In 1978 and 1979 the losses were higher.

#### 1.4 VESSEL TRAFFIC SYSTEMS

A similar system using land-based radar to pinpoint ship positions has been in existence for many years. There are currently over 200 traffic advisory systems using radar for location in restricted waterways throughout the world. Most have voluntary participation; a few, such as the Thames River, Southampton, St. Lawrence River and St. Lawrence Seaway, require participation. Some of these systems have added viewing screens and computers to calculate ships course and speed. User reaction to these systems has been excellent. Most of the operators of these radar traffic advisory systems are either Master Mariners or former federal

pilots or equivalent. In Rotterdam and Liverpool, most of the personnel are former naval officers with many years of shipboard experience and are experts in the rules-of-the-road. Although most navigational information passed to vessels is advisory, there are some exceptions where the course and speed maneuvers provided by the shore-based control facility are mandatory. Radar system errors occur because of clutter, severe weather effects and interpretation ambiguities.

A major disadvantage of radar control systems is the high cost of installation and operation; however, the reduction in number of collisions and groundings by many of these systems has been phenomenal.

The US Coast Guard and several other organizations have successfully conducted LORAN-C retransmission experiments using a VHF radio link. Extensive tests were conducted in San Francisco Bay using LORAN-C and a VHF radio link to a shore based facility<sup>3</sup>. The objective of these tests was to compare LORAN-C data against the standard radar position determination data and to improve and expand low cost VTS surveillance capabilities in the Bay. Using a Corps of Engineers tugboat and two auxiliaries with LORAN-C, a video tube display was driven by digitized data from nautical charts which had been stored on floppy discs. Position accuracy was +100 meters (330 feet) and an untrained operator became proficient in the use and control of the LORAN-C display after 4-1/2 days of training. The results were very favorable.

A unique system using both LORAN-C and radar has been developed and is operating in the Suez Canal. In Egypt, a radar system now covers Port

Said and Port Taufiq and another covers Great Bitter Lake. The remaining areas are accommodated by LORAN-C retransmission. A portable battery-operated LORAN-C unit and VHF transceiver are carried aboard by the pilot as such vessel enters the Suez Canal. The unit transmits its position periodically to shore and is forwarded to the control center at Ismalia, Egypt by dedicated phone circuits.

Operational requirements for a LORAN-C VTS in Prince William Sound, Alaska, using a VHF radio link to Valdez, Alaska were developed from the need indicated in the Alaska Pipeline Act and after extensive testing with the ARCO Fairbanks tanker<sup>4</sup>. Preparations for implementing the system have been made and this appears to be an excellent method of traffic management in restricted waters. Offshore, however, the VHF range is limited to approximately 80.45 km (50 miles) due to the line-of-sight transmission limitations between ship and shore antennas.

#### 1.5 METEOR TRAIL COMMUNICATIONS LINK

Meteor trail communications have been successfully experimented with for VTS, especially offshore. Radio signals can be reflected from the ionized path of a meteor as it enters the earth's atmosphere thereby overcoming, to a large extent, the limitation of line-of-sight VHF, and higher radio frequencies and thus extending the range of communications to the extent needed. Ships using LORAN-C retransmission have been accurately tracked from Alaska to the Panama Canal using this technique. During experiments by the Navy Electronics Command, a ship was tracked from San Francisco to San Diego and for open ocean tracking this system might be adequate.

There are several disadvantages in that a roll-call technique, (described in Section 2.2) involving a large number of ships would be difficult, if not impossible, to implement because of the time uncertainty of meteor trail occurrences. Since the time of meteor trail occurrences seems to vary between 2.5 to 9 minutes, either a shore control center interrogation of the ships or the ship's position response, or both, might not be successfully transmitted. In cases where there is a potential hazard requiring evasive maneuvers, one needs nearly instantaneous position reporting at a minimum time interval of, perhaps, as often as ten seconds. The satellite-aided VTS system, therefore, would extend the radar or VHF radio system's range from the point where it is either too expensive or insufficiently precise, to the 321.8 km (200-mile) limit and beyond, if desired.

## 2.0 SYSTEM DESCRIPTION

### 2.1 GENERAL

Under the contract, existing facilities were used as the "Control Center" to save time and costs. Ideally, in an operational system, the equipment and facilities at the University of Miami, Eden Laboratory at Malabar, Florida, and the Goddard Space Flight Center, Greenbelt, Maryland, would be located in one control center.

The University of Miami's Rosenstiel School of Marine and Atmospheric Science (RSMAS) has been involved in oceanographic research, and two of their research ships have been using the ATS-3 VHF communications link to their laboratory computer. To implement this link, the University

has set up the necessary radio-frequency (RF) and terminal equipment to communicate with the ship's shore-based company to receive experiment data from the ships to RSMAS' computer.

The Eden Laboratory at Malabar, Florida, except for the computer, has terminal and RF equipment equivalent to that of the University of Miami, and is responsible for coordinating the oceanographic community's use of the ATS-3 communication link. This laboratory's SILENT 700 remote terminal unit (RTU) also controls the University of Miami's PDP-11/55 computer and RF transmitter on/off functions, as needed, via a satellite link. The Malabar station communicated with the vessel during the tests and demonstrations and monitored the vessel's incoming position data and teletype messages.

The Goddard Space Flight Center provided the color video display capability and the PDP-11/45 computer to reduce the essential features of the nautical chart and the ship's position update at one minute (or less) intervals.

As these facilities were already in existence, no new "Control Center" equipment was required to conduct the LORAN-C retransmission experiments and demonstrations. Figure 1 indicates the functions of equipment at Goddard, University of Miami, and Malabar. Many system approaches were considered; the one using the roll-call method listing the ship's ID number appeared to be the least expensive, most flexible, and provided the most growth capability.



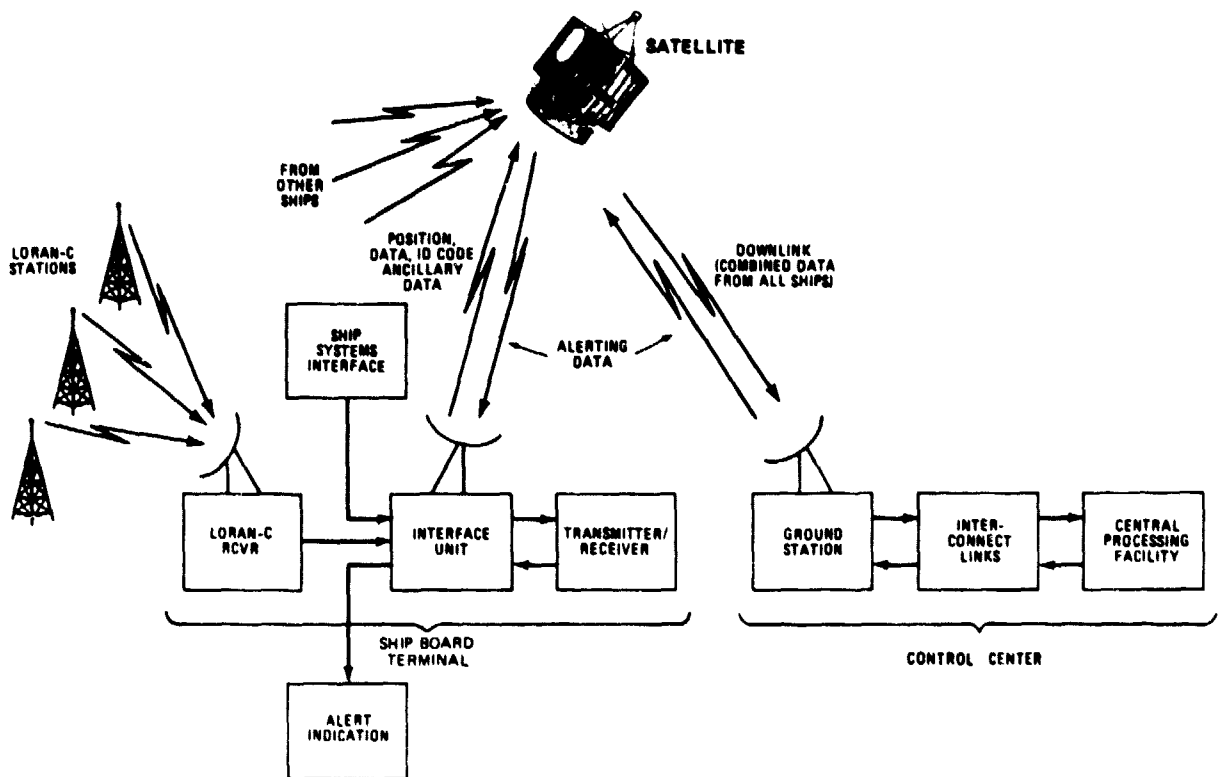

FIGURE 1: Coastal Zone Monitoring System Functional Block Diagram

## 2.2 OPERATIONS DESCRIPTION

In an operational system using a roll-call technique a computer at the Control Center automatically interrogates, sequentially, LORAN-C receivers, or other navigation receivers, aboard various vessels within the 321.8 kilometer (200-mile) limit. Upon receipt of the vessel's own ID number, each vessel answers by transmitting its LORAN-C position to the computer-driven video color display at the Control Center. Operators can view an entire coastline, from inland waters out to several hundred miles and can enlarge an area on the display in which there is a pending collision or grounding situation.

The computer also interrogates the messages entered into the memory of a teletype unit such as the ship's manifest, search and rescue data, emergency medical needs and other data on local weather conditions, reporting of fish catches, violations, oil slicks, icebergs, etc. In this experiment, most of the data was navigational information with the test vessel's teletype equipment being interrogated at 5-minute intervals. Information was transmitted at a 300-baud rate, sorted and displayed in real-time at the Control Center.

The interrogation time interval for both LORAN-C position fixes and the teletype memory can be varied manually, or automatically by the computer, depending upon operational needs; however, the minimum practical time interval for the MICROLOGIC-1000 NAVIGATOR is about 20 seconds which is needed to update each new geographical position of the ship.

Extreme geometric grid errors in LORAN-C position, for any given vessel, are monitored by the velocity vectors which are calculated by the computer between each successive reported position fixes and displayed simultaneously on the video screen. In an operational system, each major vessel entering the 321.8 km (200-mile) limit might be required to activate its satellite terminal and transmit its manifest. That far from shore, the interrogation interval, for example, might be 30 minutes and decreased to one minute in a crucial situation. In restricted waters the time interval might be as short as 20 seconds or less.

A vessel heading on a collision course with a hazard, obstruction, or other vessel would be monitored by the computer and/or the operator; an alarm signal could be sent to the vessel via the satellite or alternate

communication link. While the vessel's position is shown by the arrow-point on the CRT, the vessel's name, abbreviation, or ID number shows adjacent to ship position on the video screen display.

### 2.3 SATELLITE COMMUNICATIONS LINK

The Applications Technology Satellite Number 3 (ATS-3), a spin-stabilized spacecraft with body-mounted solar cells, was launched on November 5, 1967. The ATS-3 subsatellite point is located at 105° west longitude at one of the stable points in the geostationary orbit. This is an excellent geographical location since it provides ideal coverage of contiguous United States and the 321.8 kilometer (200-mile) coastal zone except the upper portion of Alaska. ATS-1, with its operable VHF translator, covers the remaining Alaska waters and the Pacific Islands as shown by the shaded areas in Figure 2. Unofficial estimates suggest that the ATS-1 and 3 VHF translators will be operable for the next 25 years.

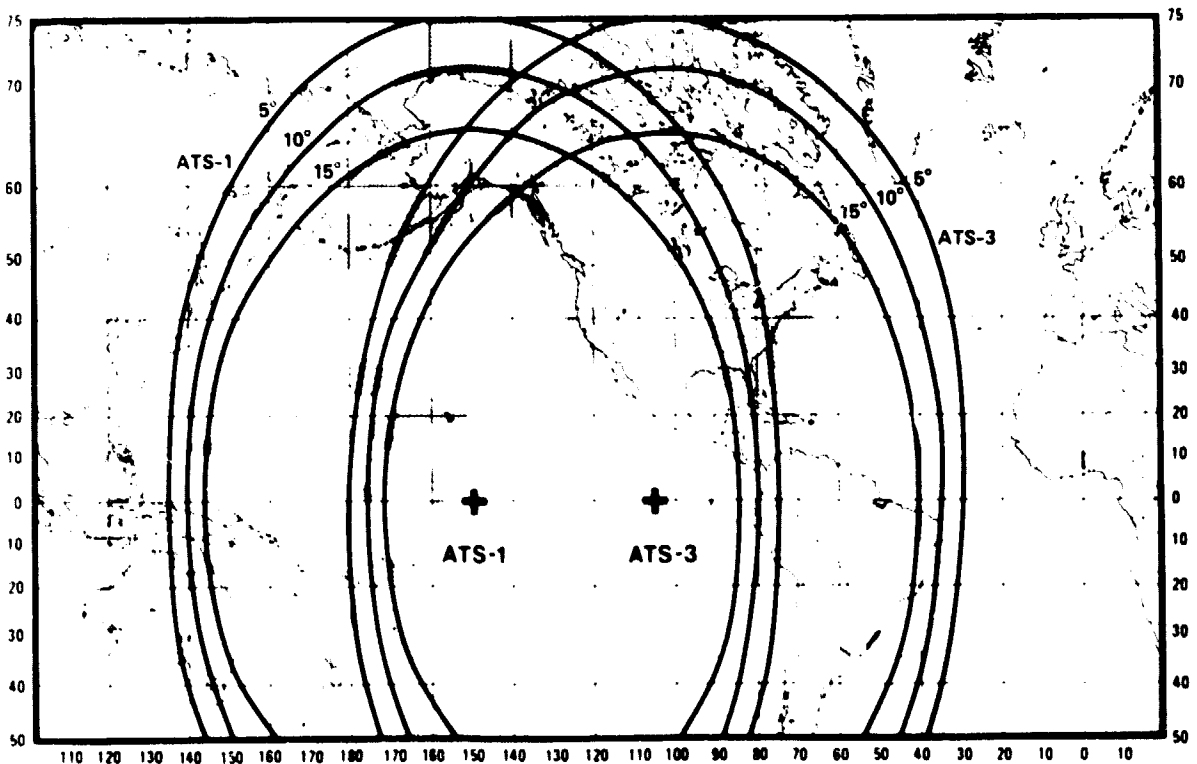

FIGURE 2: ATS 1 and 3 Coverage Areas

The satellite's VHF translator was used because of available mobile and Earth station equipment and availability of unlimited satellite time. The ATS satellite VHF system contains a linear translator with automatic gain control (AGC); the antenna system is an 8-element array of whips which are electrically switched at a speed equal, but opposite, to spacecraft rotation that forms a high-gain pattern (6 dB) pointed toward the Earth.

An effective isotropic radiated power (EIRP) of 400 watts, minimum, from the Earth's surface will provide reliable communications via ATS-3 except for polar latitudes. The VHF translator passband accommodates five narrowband FM voice channels. The link does not require the designed 100 kHz passband but, instead, operates at the lower and upper edges of the passband in the regions between the one and two dB down points, as in Table 2.

Table 2. ATS-3 VHF Voice Channels

<u>Voice Channel</u>	<u>Up-Link Frequency (MHz)</u>	<u>Down-Link Frequency (MHz)</u>
1	149.175	135.555
2	149.950	135.750
3	149.220	135.600
4	149.245	135.625
5	149.265	135.645

Total deviation for voice is 20 kHz peak-to-peak.  
 Total deviation for data is 5 kHz peak-to-peak.  
 Channel 2 was used for coordination of the tests.

#### 2.4 TEST VEHICLE

The use of the Columbia, a 13.7 meter (45-foot) motor sailer, (Figure 3) was donated by its owner, Captain Roger S. Betts, USN, Norfolk, Virginia.

Although there were several sloops available in the Annapolis area, this one was ideally suited because of the spacious main salon and on-board 110 VAC generator.



FIGURE 3: Motor Sailer "Sunshine"

## 2.5 ON-BOARD SYSTEM

### 2.5.1 Antennas

Two separate antennas, one for transmit and the other for receive, were used for the first and second experimental excursions and for the final demonstration tests in the lower Bay. These antennas were manufactured by KLM, Morgan Hill, California.

A manually-controlled commercial TV antenna-rotor drive was used to point the VHF antennas in azimuth toward the satellite as the ship changed

course. Normally, these antennas each have eight elements; however, the top three were removed on each in order to broaden the radiation-pattern beamwidth and reduce mechanical inertia. There was sufficient radiation-gain margin with the reduction to five elements, and the broader beamwidth permitted use of a fixed elevation angle for communication with the ATS-3. The antennas operated well and there was no excessive loss of signal due to the ships roll. The azimuth control dial on the antenna rotor was rotated the number of degrees corresponding to a change in course but in the opposite direction. For the tests and demonstrations, an azimuth of  $230^{\circ}$  and a  $35^{\circ}$  elevation angle to the ATS-3, relative to the deck, was maintained. On occasion, the vessel roll was  $+15^{\circ}$  which did not jeopardize the data quality. An EIRP of 1000 watts resulted from the power amplifier and the transmit antenna power gain.

#### 2.5.2 Power Supply

The sloop used 12vdc power for many of its subsystems; a 3.5 kw ONAN, diesel-fueled, generator provided 125 vac for the remaining ships equipment and for the antenna rotor, 350-watt power amplifier, the teletype, LORAN-C receiver communications central processor (CCP), the Clegg Mk III transceiver and lighting.

#### 2.5.3 Transceiver

The transceiver is an inexpensive unit manufactured by Clegg, Inc., Lancaster, Pennsylvania for amateur band use. Figure 4 shows the transceiver with a small preamplifier mounted on top of the chassis. Frequencies were changed to those of the ATS using the appropriate crystals and then converted from phase modulation to frequency modulation to accommodate

PCM data transfer. The unit operates in a lower power output mode of 10 watts or highest power output of approximately 20 watts which was used to drive the 350 watt power amplifier.



FIGURE 4: Transceiver and Preamplifier

#### 2.5.4 Preamplifier

The preamplifier (Figure 5) uses a bi-polar transistor having approximately 12 dB gain with a noise figure of 2.5 dB. It is commercially available from Angle Linear, Inc., in California.

#### 2.5.5 RF Power Amplifier

The RF power amplifier (Figure 6) is an all mode 350 watt VHF amplifier and is commercially available from RF Power Labs, Inc., Kirkland, Washington. It has an auxiliary output of +13 volts at 3 amperes.

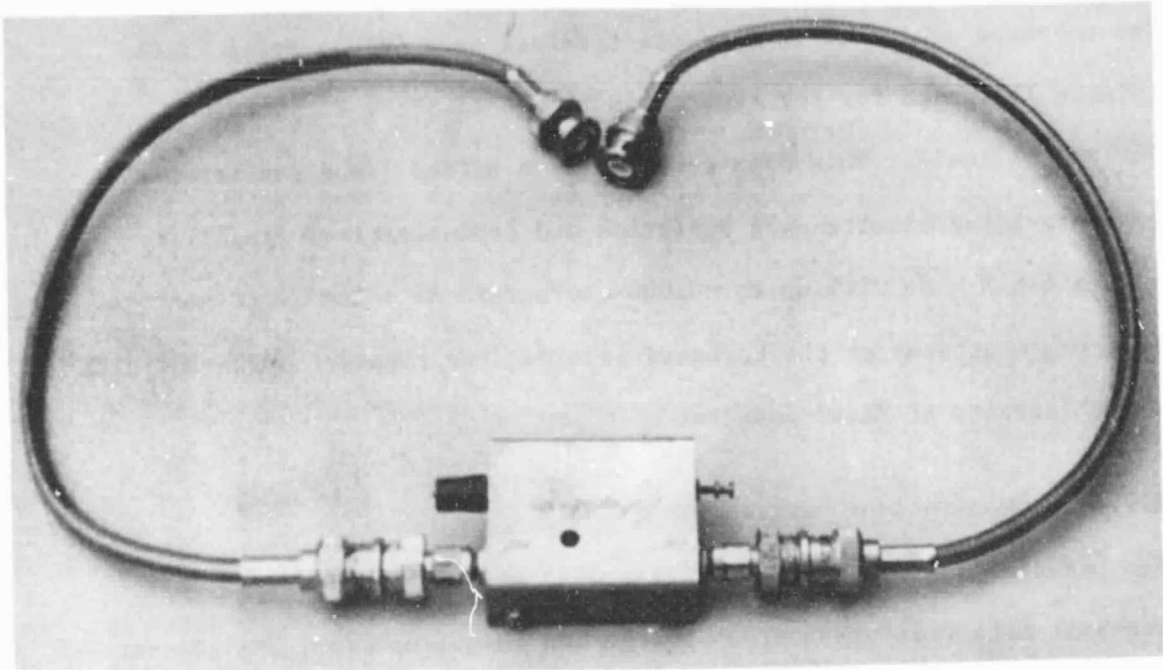

FIGURE 5: Close-up of Preamplifier

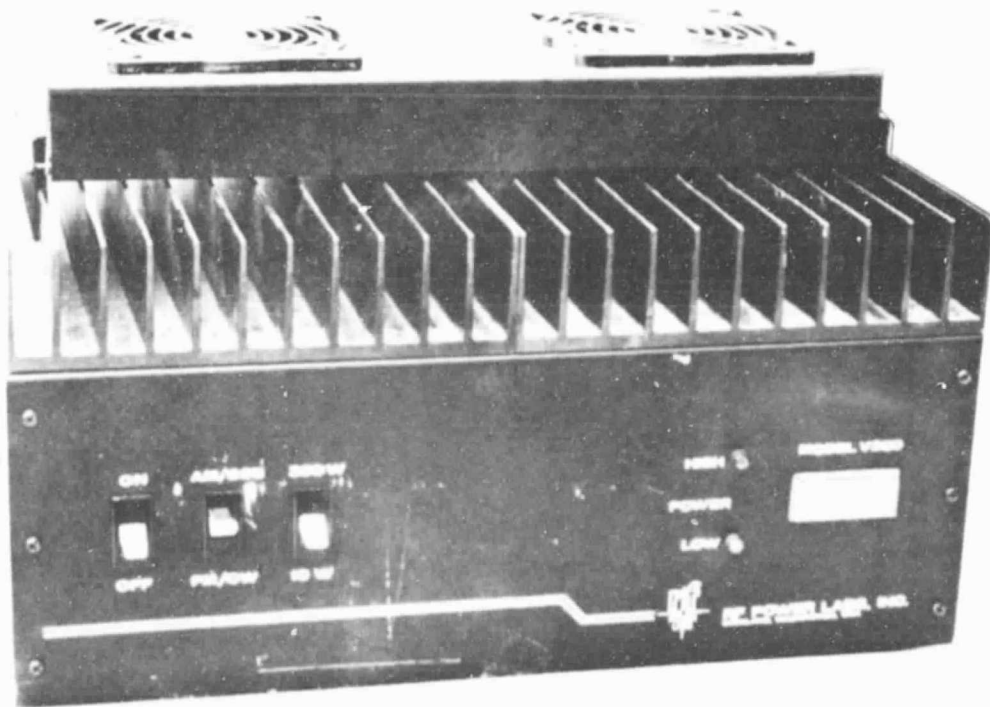

FIGURE 6: RF Power Amplifier

ORIGINAL PAGE IS  
OF POOR QUALITY



### 2.5.6 Communications Terminal

The teletype equipment is a remote terminal unit (RTU), Model 43BSR (Figure 7) loaned for the experiment by the TELETYPE Corporation, Skokie, Illinois. This data terminal is a buffer "send and receive" unit providing simultaneous operation and communications capability in the batch mode with up to 20,000 characters of solid-state storage. Selectable options at the keyboard provided the required operation with the University of Miami computer.

### 2.5.7 Communications Central Processor (CCP)

The basic circuitry in the CCP (Figure 8) was originally designed to transmit data from oceanographic research ships; however, changes had to be incorporated to accommodate the commands to the teletype buffer and the LORAN-C MICROLOGIC-1000 receiver. This project used for the first time a CCP in an interrogation link involving navigation and teletype data. A very important feature of this system is the type of data coding and detection which permits the processing of very low level signals by inexpensive terminal equipment. In addition, the data is formatted in accordance with the American Standard Code for Information Interchange (ASCII). The electrical interfaces of the equipment are compatible with the RS-232 EIA Standards.

The synchronous data which is received and transmitted by the CCP's logic coder/decoder is in accordance with the Inter-Range Instrumentation Group (IRIG) PCM Telemetry Standard #106-73. The PCM waveform is a bi-phase L-type which frequency-modulates the RF carrier. By using

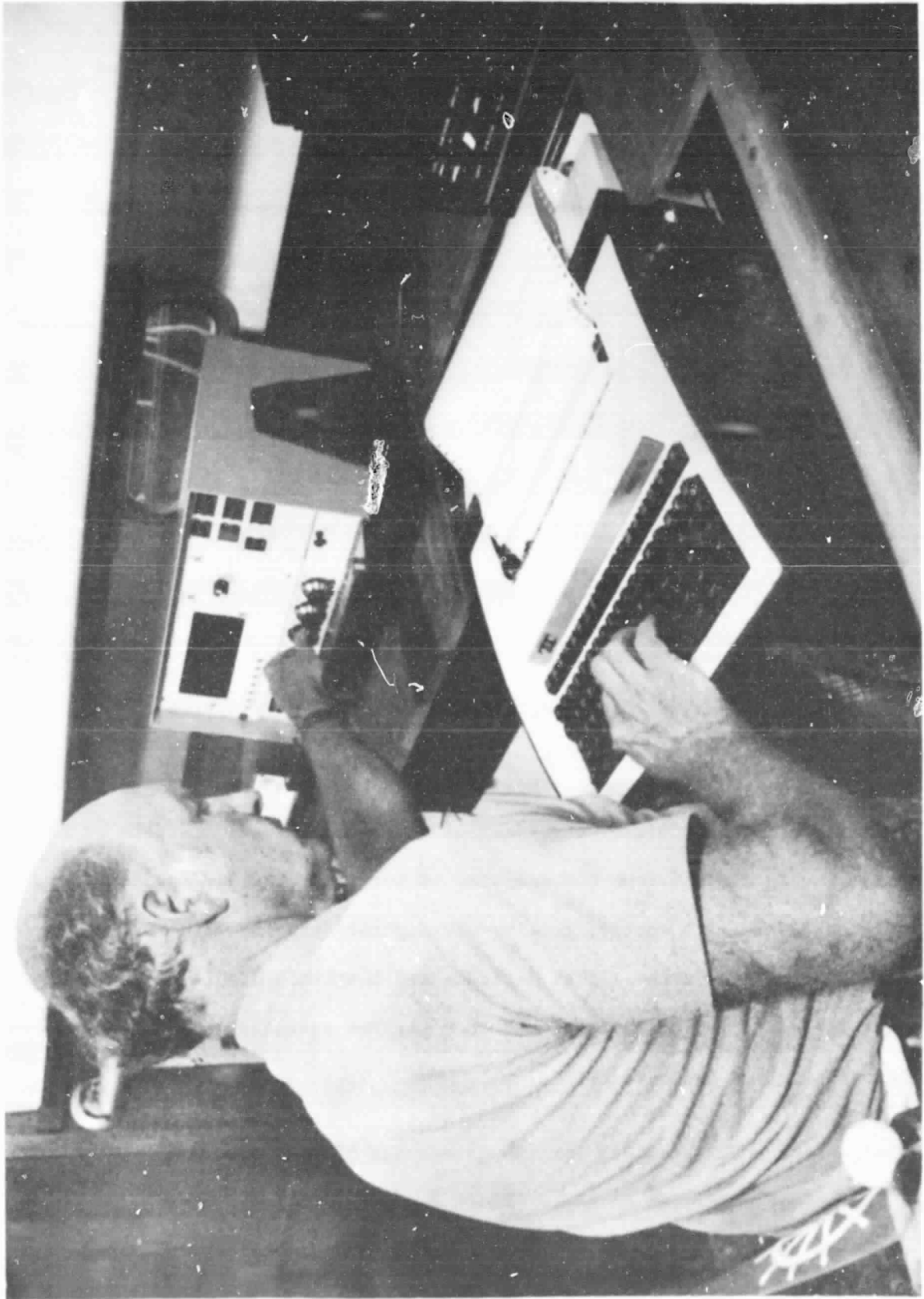

FIGURE 7: Communications Terminal in Operation

ORIGINAL PAGE IS  
OF POOR QUALITY

modified synchronous detection a very high signal-to-noise ratio is achieved without the need for precision oscillators and phase locked loops in the transmitter or receiver.

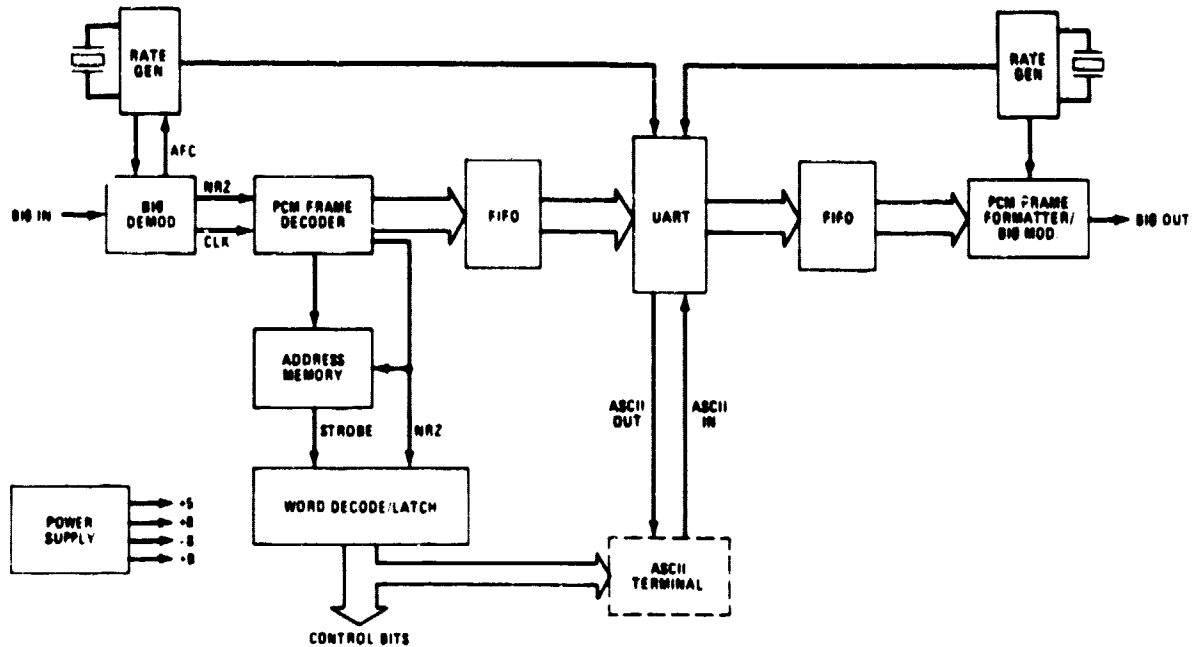

FIGURE 8: Communications Central Processor System Functional Block Diagram

The CCP contains the ships address and provides for a check of the frame synchronization and bit synchronization of the incoming ASCII data stream. When the PCM command from the computer is received, the CCP decoder will, with the correct ID number, receive the digital data from the LORAN-C output which drives the actual latitude and longitude displays. This data is fed to the transmitter and then via the satellite to the Control Center receiver and computer.

Design of the CCP provided for two categories of indicator lights displayed on the front panel, as shown in Figure 9. One group of seven lights arranged vertically on the left side of the panel indicates the status

of power to the CCP, the quality of the incoming PCM signal frame, and data synchronization and phase lock. The second group, arranged horizontally (numbers zero through seven), indicates which type of data was commanded to be transmitted from the vessel.

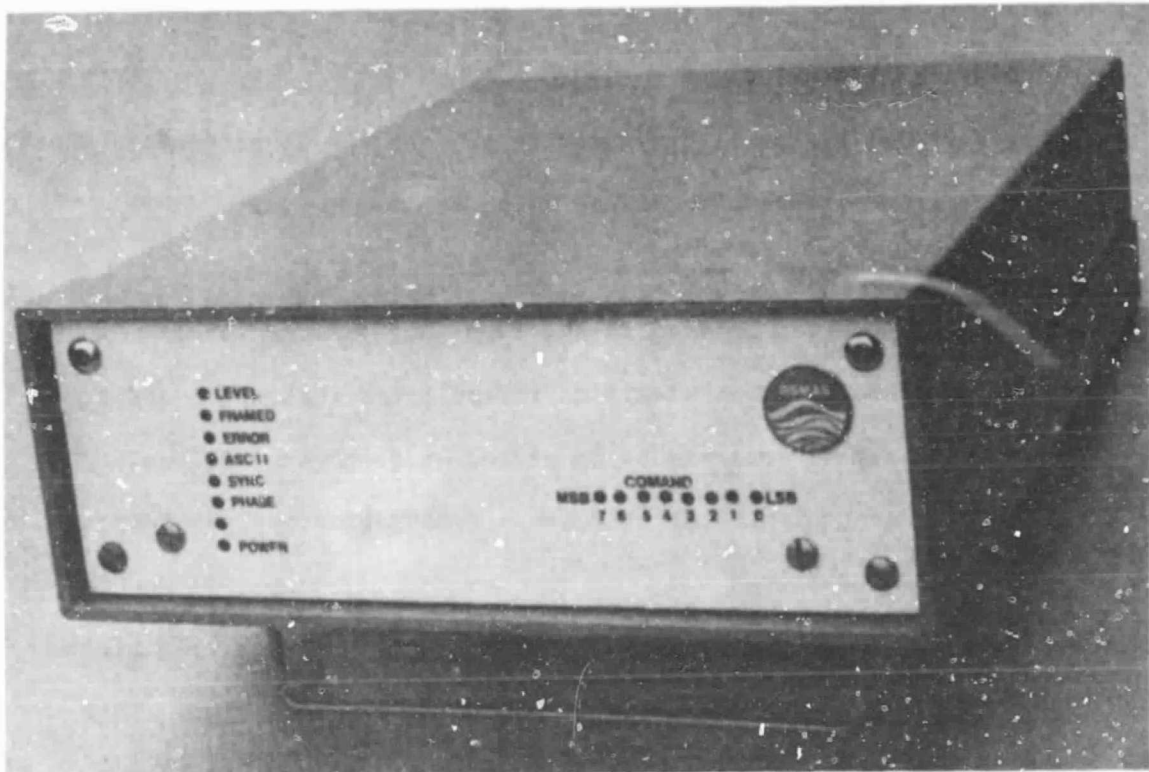

FIGURE 9: Communications Central Processor System

When operating in the receive mode, the CCP phase locks on the incoming PCM data which is in the bi-phase-L format. It converts data from synchronous PCM/TDM to asynchronous, RS-232 compatible, ASCII data. The CCP also receives the vessel address (ID number), decodes it, and then executes the command functions; in this case, requests latitude/longitude from the LORAN-receiver and messages from the teletype buffer.

The CCP also commands the keying of the transmitter and provides the timing information for the duration of the transmission. When the transmission from the vessel is complete, the CCP shuts off the transmitter and resets its command register and remains in the stand-by condition waiting for the next command.

#### CCP-STATUS INDICATORS

The vertical status lights are labeled from top to bottom and provide indications which are described below.

"Power" - light on; power on

"Level" - this can be used to set input and balance levels. It should be on always as it indicates that noise and/or signal power is being picked up from the receiver.

"Frame" - light indicates that frame synchronization has been established.

"Error" - a momentary light indicates that one or more bit errors have been received in the synch word time slot. This does not necessarily mean that the program is thrown out; however, if there is a continuous error signal then the circuit has lost frame synch and the "frame" light will go out. This is internally programmable from 1 through 16 frames. In this case it is programmed for 2 frames before it goes out and shuts off the ASCII bit stream to the RTU.

"ASCII" - light indicates that the addressed vessel is now receiving ASCII data.

"Synch" - light flashes once for every 16 ASCII characters indicating that the proper synchronous word has been recognized. If the "synch" light misses then the "error" light comes on.

"Phase" - If the phase light blinks slowly the base station signal has adjusted its oscillator frequency to the mobile transmitter frequency. If it blinks at a high rate, there may be enough signal to lock up the clock, but not enough signal to get good data. Detection is done in the time domain rather than in the frequency or phase domain. The receiver phase locks to the data rate rather than the carrier, and the circuit compares the phase difference between the data receiver oscillator and the data transmitter oscillator. If the light stays "on" then the control center is not sending data, and the circuit is searching for the control center master oscillator reference phase.

"Command Indicator" - The present arrangement uses only 3 of the total 7 available circuits. The balance of these circuits could be used for at least four functions of a variety of options. For example, these could be used for data readouts from other sources such as buffers on acoustic and radar signatures, and the time and/or phase differences of signals received by the vessel from other satellites and navigation systems. The CCP could trigger

internal or external alarm systems or cause beacons or homing devices to be energized. In this case, the functions indicated by the three circuits "0", "2", and "5" are described below.

"Zero" - light "on" indicates that the Control Center is transmitting to the teletype by turning on the ASCII bit stream from the CCP to the teletype by sending a "DC1" (device control #1) to the teletype remote terminal unit (RTU).

"two" - light "on" indicates that the RTU is transmitting its buffered data (text message) to the CCP.

"five" - light "on" indicates the LORAN-C receiver has been interrogated and the computation of latitude and longitude is transmitted to the CCP data formatter which converts asynchronous ASCII data to synchronous PCM data. The CCP then sends this data to the transmitter which is also keyed by the CCP.

#### 2.5.8 LORAN-C Receiver

The continuous position determination was accomplished using a LORAN-C MICROLOGIC-1000 NAVIGATOR (Figure 10). This instrument, one of several types commercially available, has an internal program to provide real time continuous readout and display of latitude and longitude. Two NAVIGATORS were furnished to the Baker Development Corporation by the Goddard Space Flight Center.

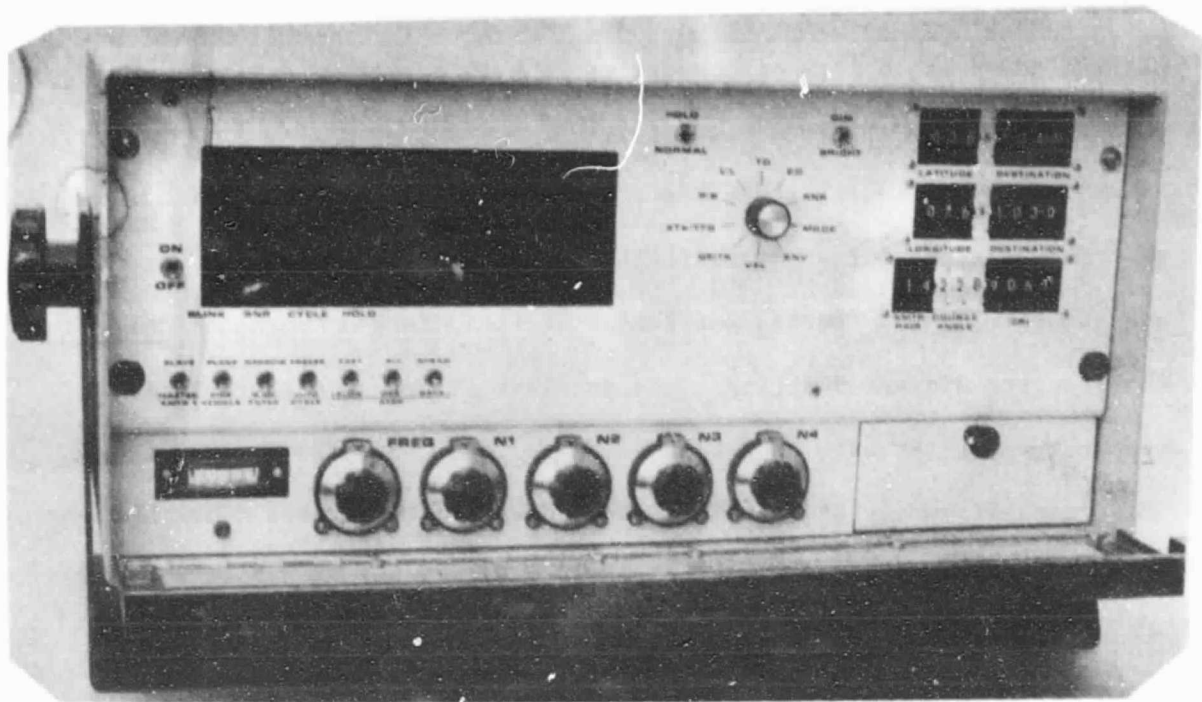

FIGURE 10: LORAN-C Micrologic-1000 Navigator

In 1976 when plans were being made for this project, several off-the-shelf LORAN-C receivers were considered for using in the experiment. At that time, most of the proven commercial receivers produced and displayed the time differences (TD) in propagation of the signal between the master station and the secondary transmitters. In this concept of position monitoring, TD's would have to be converted to latitude/longitude at the control center and be displayed on a video monitor. Unless there was conversion to latitude/longitude at the vessel, additional computation capability and complexity would have to be shifted to the Control Center.



The Goddard Space Flight Center, therefore, procured a receiver which had the added capability of converting TD's to latitude/longitude which were displayed on the receiver panel.

The LORAN-C MICROLOGIC-1000 NAVIGATOR performed well throughout the tests and demonstrations. During one series of tests in the Chesapeake Bay, the receiver did not function. The receiver failed at normal operating temperatures after warm-up due to an electrical connector failure in the main computer module and display board; however, tests were continued by using blower fans to maintain the receiver at ambient temperature.

#### 2.5.9 LORAN-C/PCM-CCP Interface

The Rosenstiel School of Marine and Atmospheric Science (RSMAS) of the University of Miami designed, fabricated, and tested the electrical interface module (Figure 11) for the ML-1000 NAVIGATOR. Location of the module in the receiver is shown in Figure 12. Prior to designing the interface, an operational philosophy was adopted which consisted of two major provisions. The first would be that when the PCM Communication Central Processor (CCP) requested an update of latitude/longitude, the latitude/longitude data would not be available until after the LORAN-C receiver had completed the update. Second, if an update of latitude/longitude should occur during a transmission, the new update would be ignored. A functional block diagram of the LORAN-C receiver subsystem is shown in Figure 13.

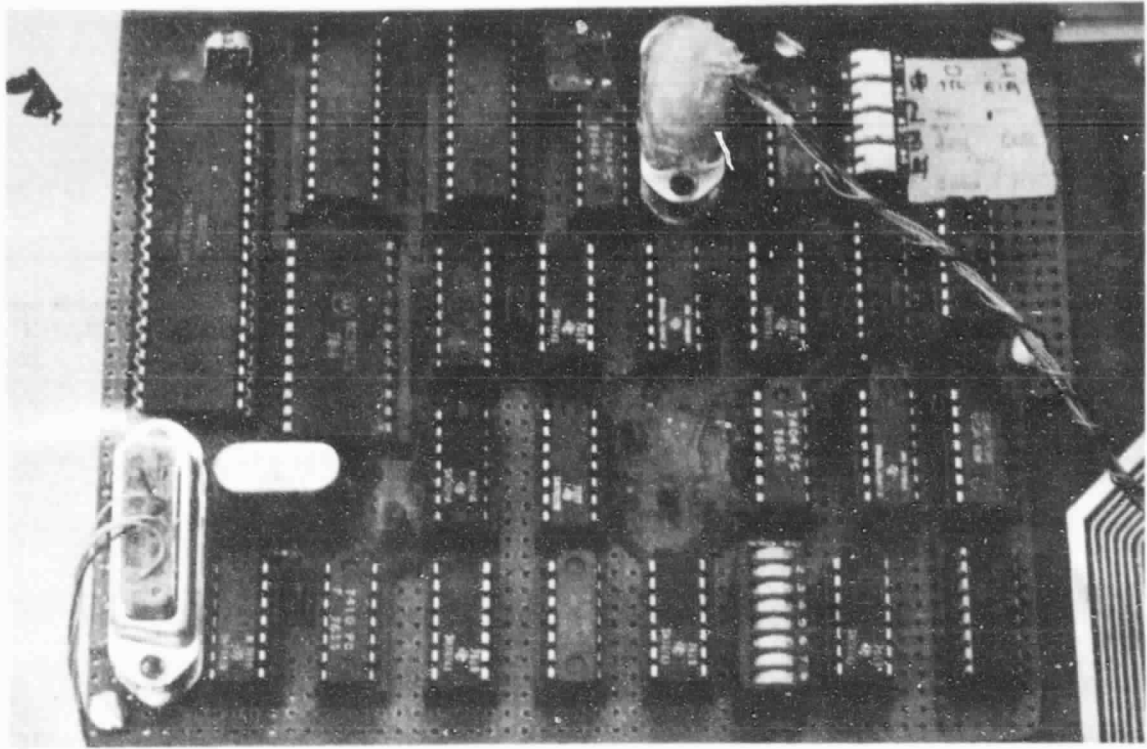

FIGURE 11: Electrical Interface Module

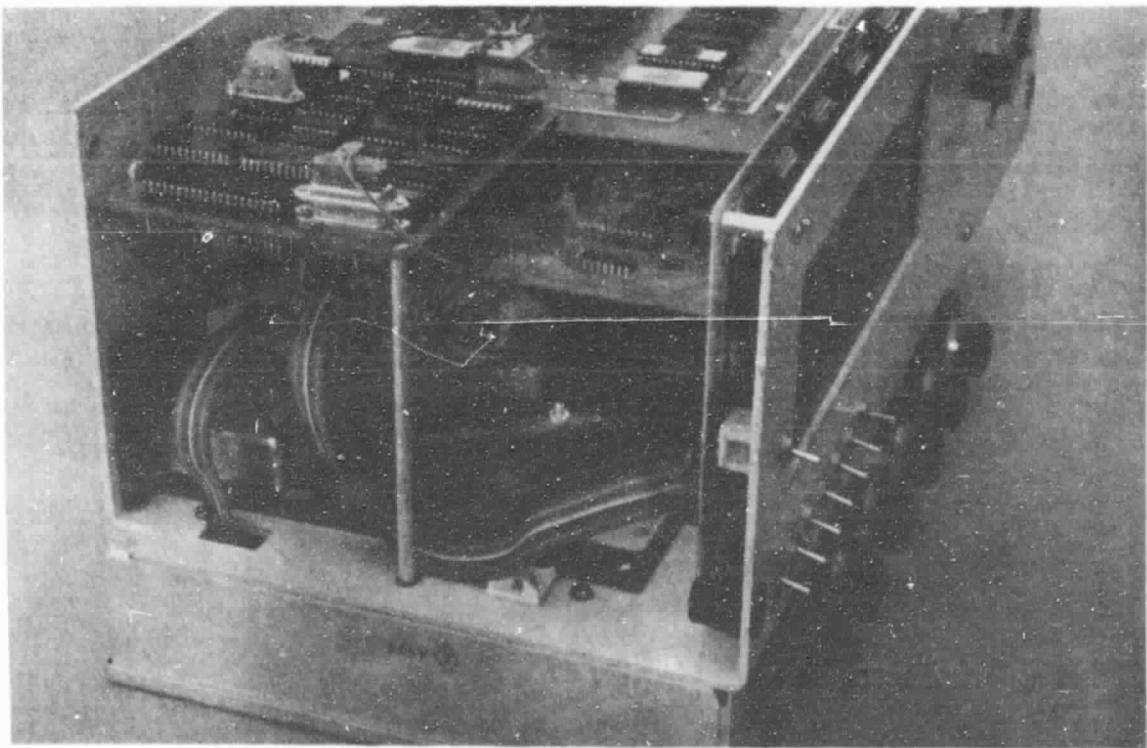

FIGURE 12: Electrical Interface Module Mounted in ML-1000 Navigator

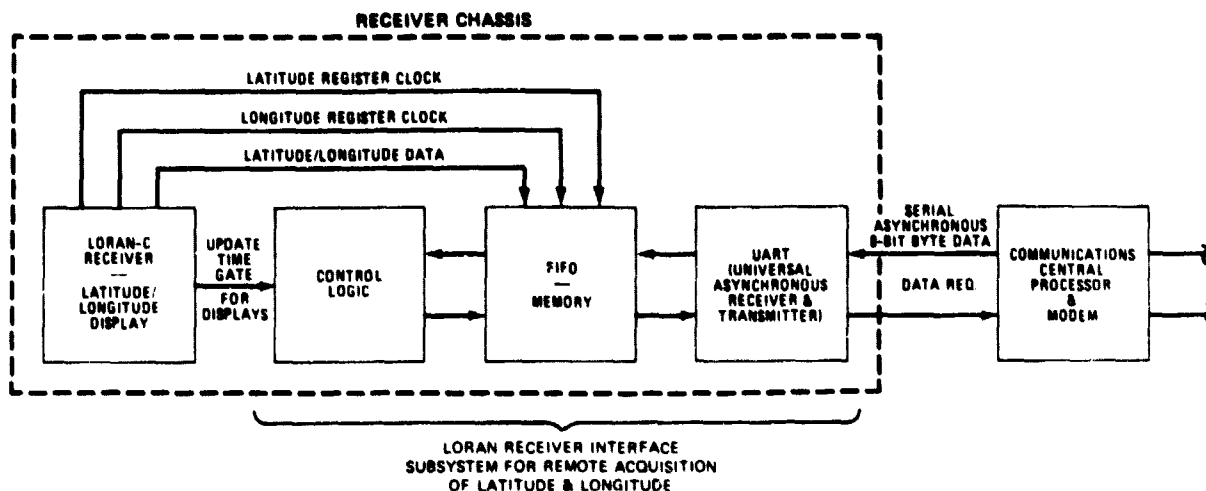

FIGURE 13: LORAN-C Receiver Subsystem

Data from the ML-1000 is output in two 40-bit serial bit streams. The first contains the data from the upper display (latitude); the second, the lower (longitude). Each 40-bit data stream contains one byte of status information and 4 bytes of data. (The outputs are from PMOS gates and are fed directly to the interface via a DIP Leader to a D-type 9 pin connector.) Each data stream is controlled by an ENABLE, UPDATE, and a CLOCK (upper clock or lower clock).

At the interface, data is stored in Fairchild 9403 FIFO's until a transmit request is received. At that time, data will be sent to the PCM system via an Intersil 6402 UART one byte at a time. After all ten bytes have been sent, the interface is ready to be updated by the ML-1000. It should be noted that the transmission of data is a destructive read, and new transmit requests will receive only nulls until an update has occurred. Further, it is important to note that all zero's stored in the FIFO's are modified to BDC 10's prior to latching by the UART; this is to allow transmission of the expected number of characters.

● GENERAL OPERATIONAL DESCRIPTION

A schematic diagram of the LORAN-C/PCM-CCP interface is shown in Figure 14. The interface uses the UPDATE from the ML-1000 as an enable for both serial data streams. At the beginning of the update cycle, the proper FIFO is reset and enabled. Some microseconds after UPDATE, data and the appropriate clock are also output by the ML-1000. The serial data is then stored in the appropriate FIFO. The two UPDATE's are, approximately, 6.7 ms in duration and are separated by 22 ms. The entire update period is less than 40 ms in duration.

Data is output by the interface when the transmit request flag is available from the PCM system. A delay of either 2 or 4 PCM data frames is initiated to allow the transmitter to warm up and the PCM system to establish sync. After the delay has elapsed, the data is available to a UART as 10 one byte words. The data is transmitted at either 110 or 300 baud rate to the PCM system.

For normal operation of the interface, it is important to note the following information on switches and jumpers:

- A-D7 Switch
1. Do not change switches in D7 with power on.
  2. S1 either EIA or TTL output.
  3. S2 unused -- has +5 and = attached.
  4. S3 baud rate 110 or 300.
  5. S4 delay 2 frames or 4 frames.

B-Switch A6 - These switches control a test circuit which will simulate transmit requests -- they should be used only for testing purposes.

C-Jumper E-4-3,4 Control +15v to EIA (D4) line driver - Must be in for EIA data.

● DETAILED OPERATIONAL DESCRIPTION

Signals from the ML-1000 are level-shifted from PMOS to TTL levels using a CMOS 4049 (C3) inverting buffer in conjunction with 10K resistors. At +5v, the buffer operates normally and at -10v, the resistors limit the current drawn from the gate clamping diodes to a safe value.

After the ML-1000 signals have been buffered, interface operations begin. (The schematic diagram, Figure 14, and timing diagram, Figure 15, are referenced in the following explanation.) At the beginning of an update cycle, interface enable, IE(C4-5), goes true and is used to enable the interface, if transmit enable, TE(A3-5), is low. If TE is high, a data transmission is in progress and the update is ignored. If TE is low, a sequence of operations begins to condition and load the FIFO's. For a normal cycle, master reset<sub>o</sub> (A2-12) clears D2 and the serial data input is enabled LY IES<sub>o</sub> (D5-6). Data (B6-6) and then upper clock (B6-2) become active as determined by the ML-1000 and the upper display data is stored. At the completion of an upper output cycle, UPDATE (A4-2) changes stage and sets interface disable, ID(C4-9), which completes this portion

of the cycle. A similar ML-1000 operation occurs with the update of the lower display data with the exception that lower clock rather than upper clock is active. During the second UPDATE, serial data is enabled to D3 by IES<sub>1</sub>, (D5-8) and D3 is reset by MR, (A2-8).

At this point, both FIFO's are loaded and data may be extracted upon demand. If a Transmit Request (A1-2) has not been received by the time a new update cycle occurs, the old position data is discarded. However, during data extraction from the FIFO's, any attempt to update will be ignored due to transmit enable, TE(A3-5). After a TE has been received, a delay determined by C2 (a baud rate generator) and C5 and B7 (2 dual 4 bit binary counters) elapses prior to the enabling of the Transmit Register Clock, TRC (B3-11). This delay allows the transmitter to warm up and the PCM system to establish sync. When TRC becomes active, the UART,

C1 begins to transmit data to the PCM system at either 110-baud or 300-baud rate. Output from the UART may be in either EIA or TTL format. AT the end of the transmission, both UART and FIFO's set to receive a new update.

Circuitry not covered in the discussion are a power on reset (C3-14 and C7-5) which resets the UART, and a TE simulator in the dashed box. The latter circuit is designated to provide a method of testing the interface operation without a PCM system.

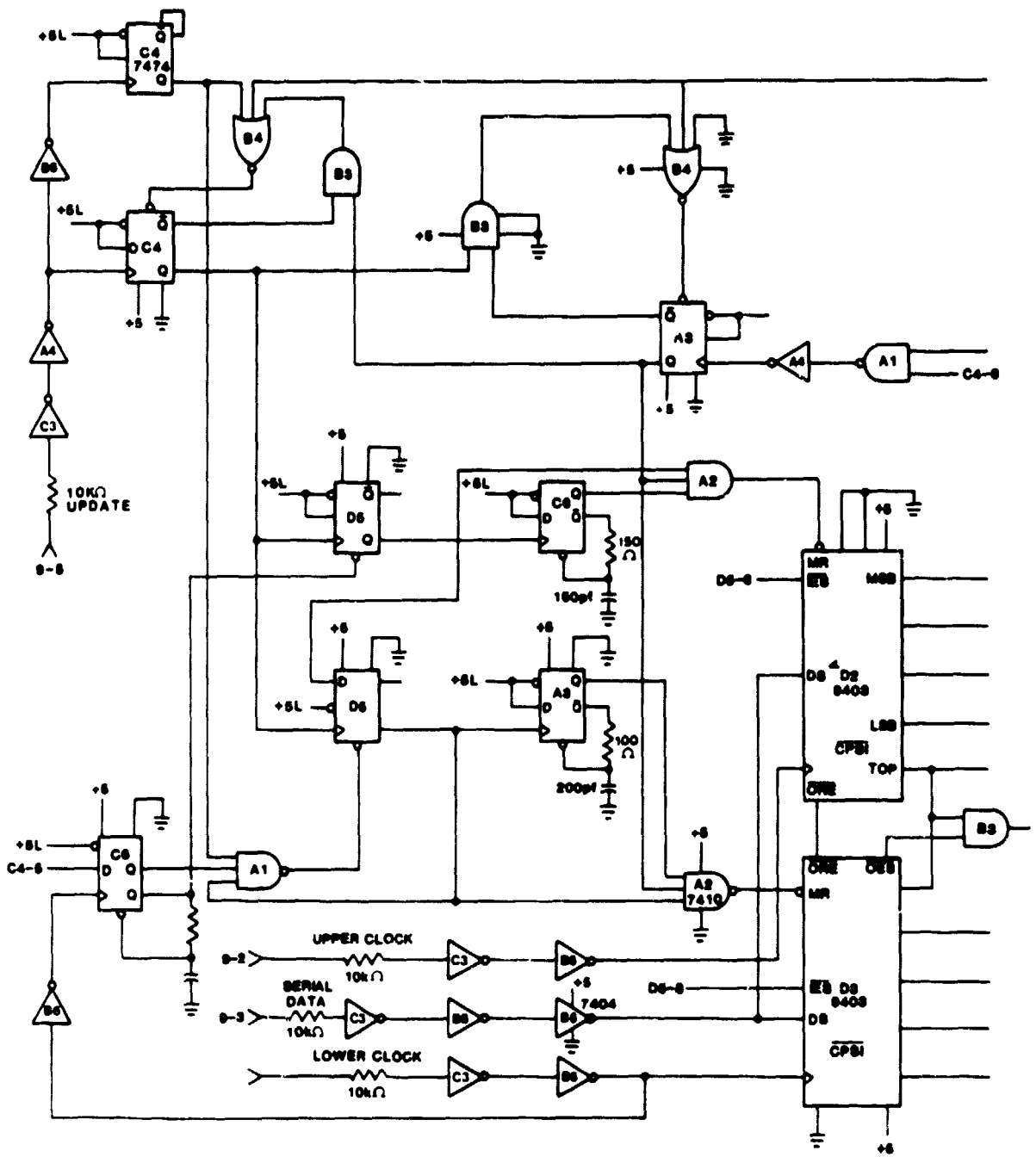

FIGURE 14: Schematic Diagram of LORAN-C/PCM-CCP Interface Module

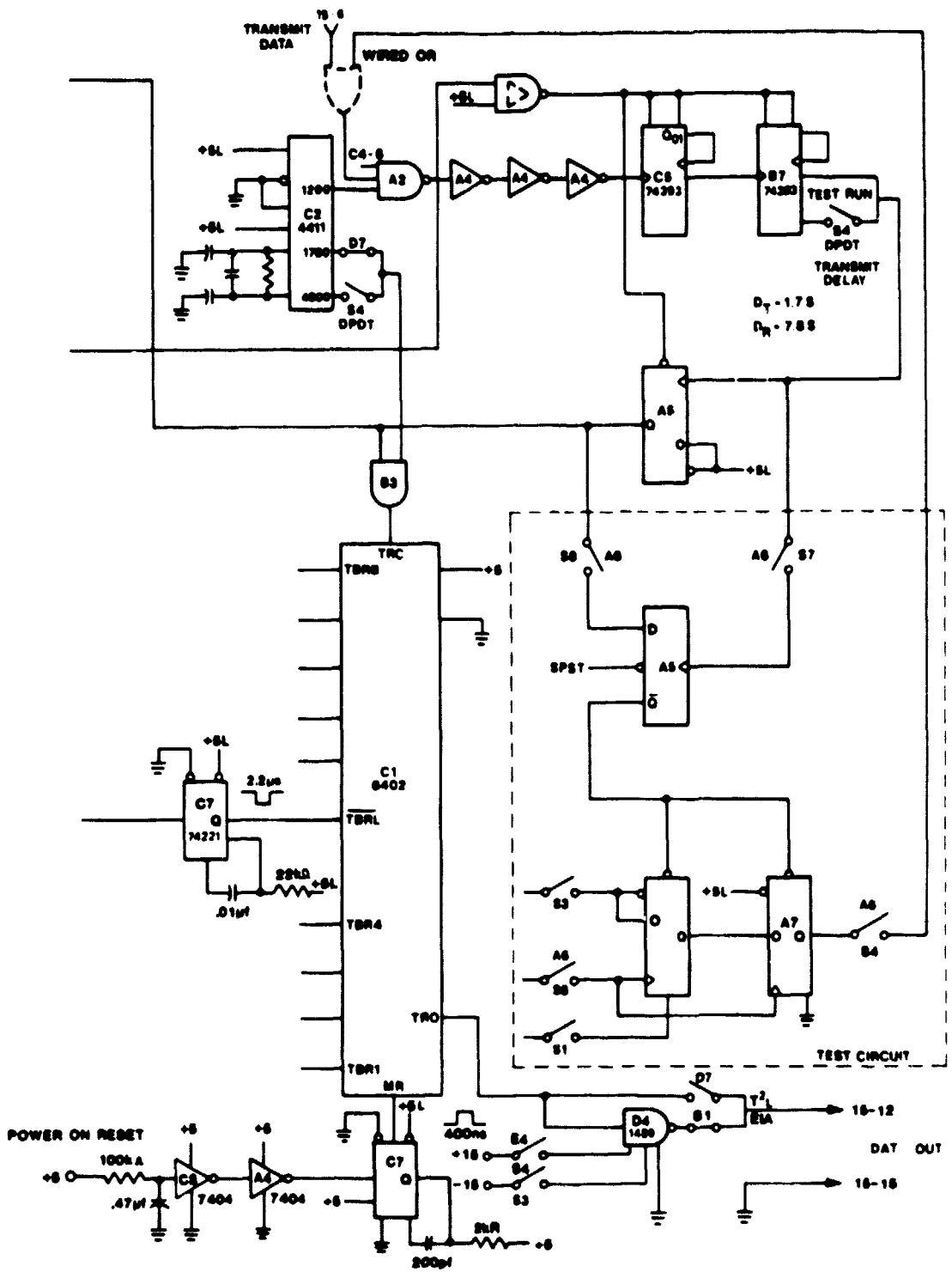
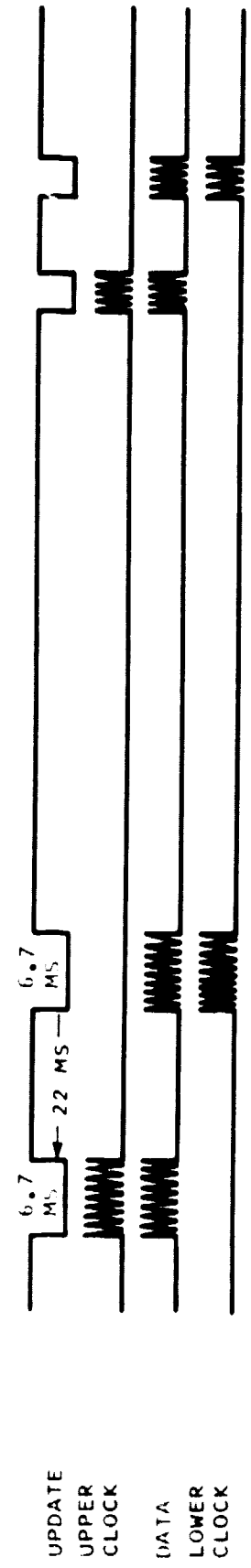

FIGURE 14: Schematic Diagram of LORAN-C/PCM-CCP Interface Module



SCALE NOT CONSTANT

ML 1000 SIGNALS



INTERFACE SIGNALS

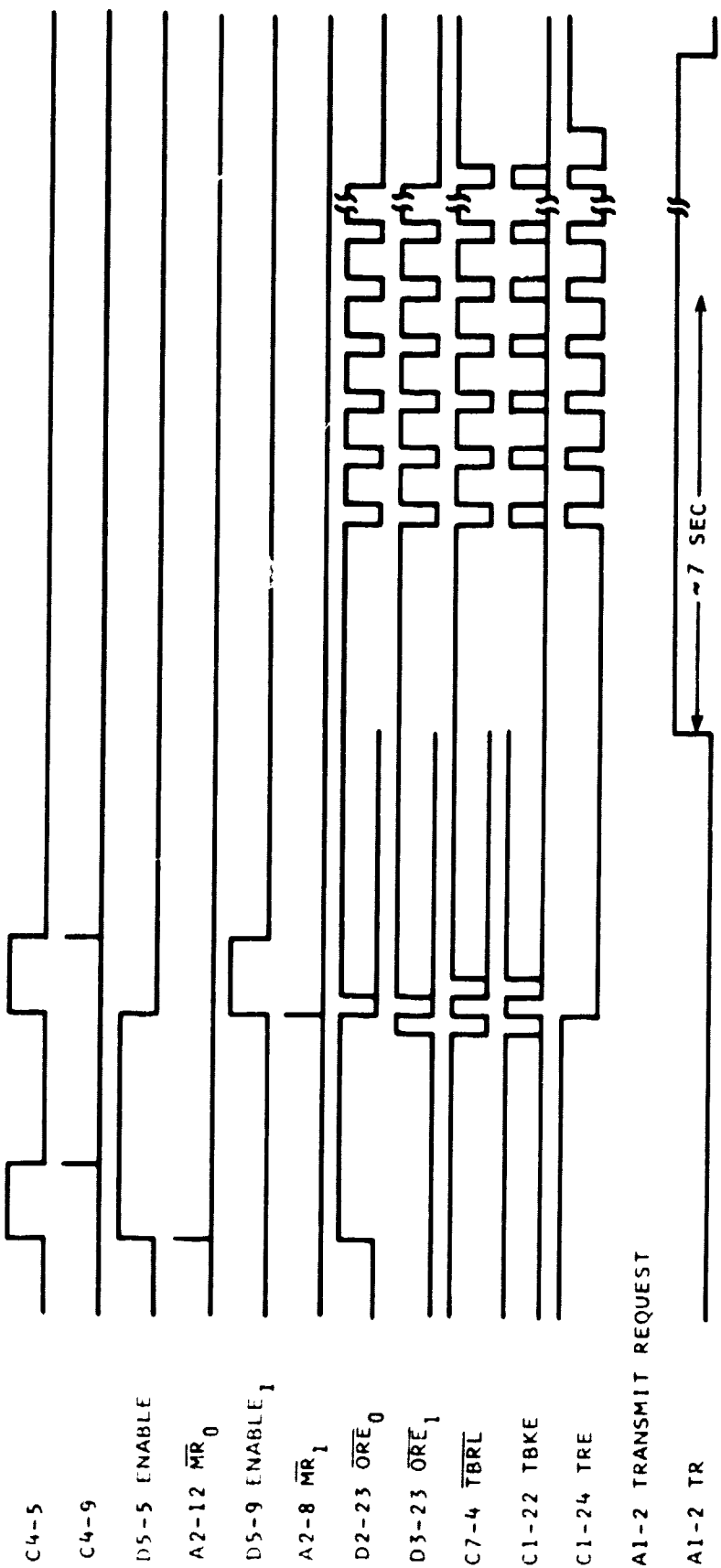

FIGURE 15: Timing Diagram

## 2.6 COMMUNICATIONS LINKS

Figure 16 shows the actual link for conduct of the demonstrations. The Malabar Station commanded the Miami transmitter and computer to begin automatic data acquisition by entering the proper code into the RTU. The Miami computer sent the vessel address and commands via its transmitter to the satellite which relayed this data to the vessel. Upon receipt of its address the Communications Central Processor (CCP) decodes each command and requests data from the LORAN-C ML-1000 NAVIGATOR and the teletype buffer. These data were transmitted from the vessel to Miami via ATS-3, decoded, entered into the computer buffer, and filed; the data were then fed to the 103J MODEM. A telephone link was brought up during the demonstrations and data was passed from the Miami MODEM to the GSFC MODEM and into the PDP-11/45 which outputted to the Image 100 system and the video color monitor. GSFC messages intended for the vessel were sent from the operator control keyboard at the Control center to Miami via the phone line. These messages were stored in the PDP-11/55 computer until the appropriate time interval passed and were then relayed to the vessel.

The communications path for the demonstrations was circuitous, when compared to an ideal arrangement. However, GSFC has not had ATS-3 Earth station VHF equipment in operation for several years; consequently, this arrangement was expedient.

## 2.7 DISPLAY AND CONTROL SYSTEM

The heart of the Vessel Traffic and Coastal Zone Monitoring System is the control center with computer and video display capabilities. Software for mapping, image display, and control was developed at Goddard

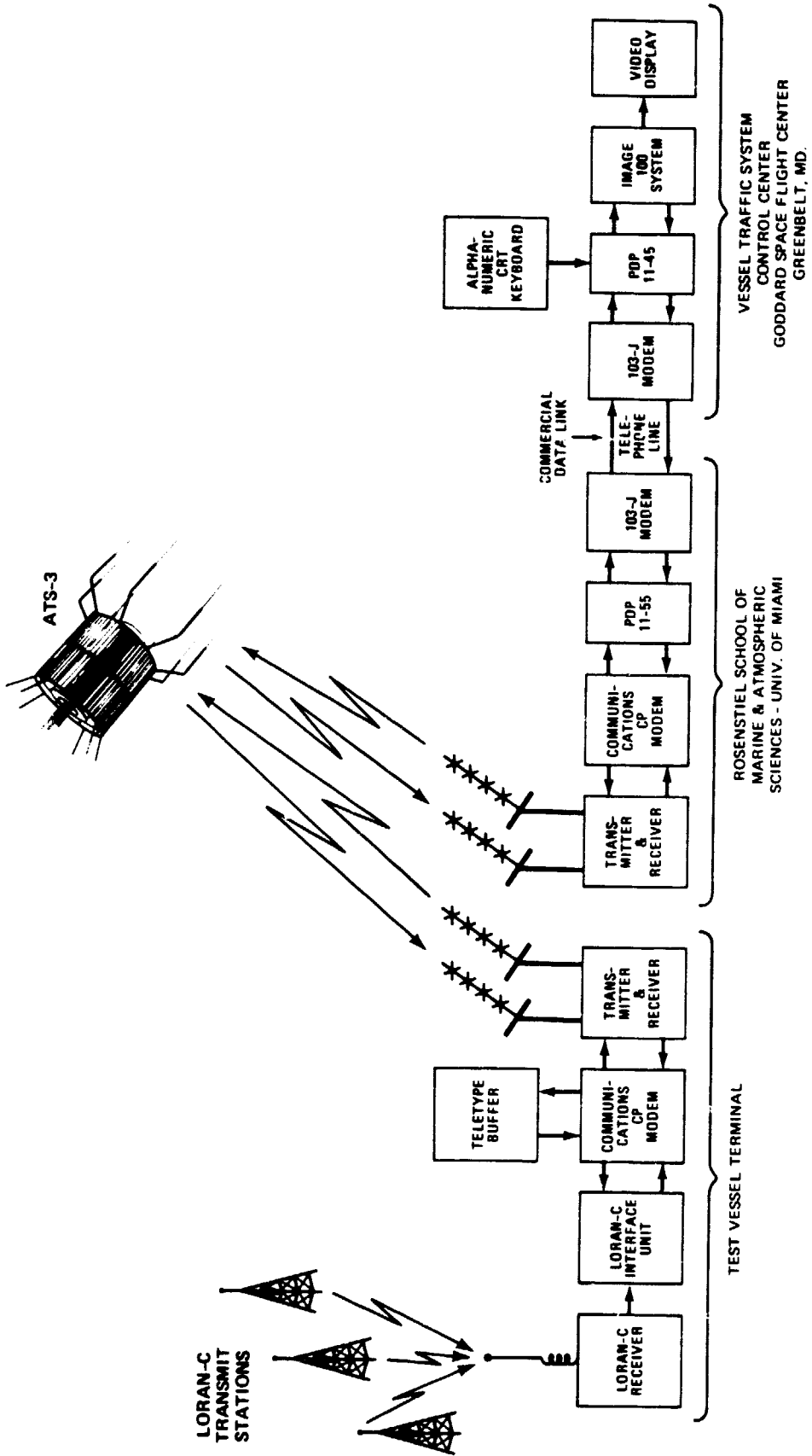

FIGURE 16: Communication Links for Test and Demonstration of Vessel Data and Position

Space Flight Center, Greenbelt, Maryland, using the existing Atmospheric and Oceanographic Information Processing System (AOIPS) with the PDP-11/70 and PDP-11/45 computers and the GE Image 100 image analysis display terminal. These facilities served as the operations center for the experiment and demonstrations.

Although this VTS was implemented using two computers, a single computer configuration would be sufficient. All run-time processing was done on the PDP-11/45. The PDP-11/70 was used off-line for supporting the software development and for rapid building and sorting of large image files which were stored on a dual-ported disk shared between the PDP-11/45 and the PDP-11/70.

The software consists of two major subsystems; the chart generating subsystem and the display processing subsystem is shown in Figure 17. Chart features to be displayed are first identified and assigned an ID code. Colored areas, e.g., land areas and water areas of constant depth, must be defined by closed polygons. Segmented lines may be used to define such non-area features as channel boundaries, bridges, etc. The latitudes and longitudes of all polygon corners and link break points are then manually entered into the computer via a standard text editor, along with their corresponding ID codes. Base charts in latitude and longitude are then created on disk files containing images of the desired charts at various magnification scales or zoom levels. The display processing subsystem transfers the images from the disk to the color display terminal and simultaneously displays the ship's position and teletype text as

received from the vessel. The ship's velocity is computed and displayed simultaneously. The plotting and text display is done on non-destructive bit-plane overlays, and is independent of the color chart background.

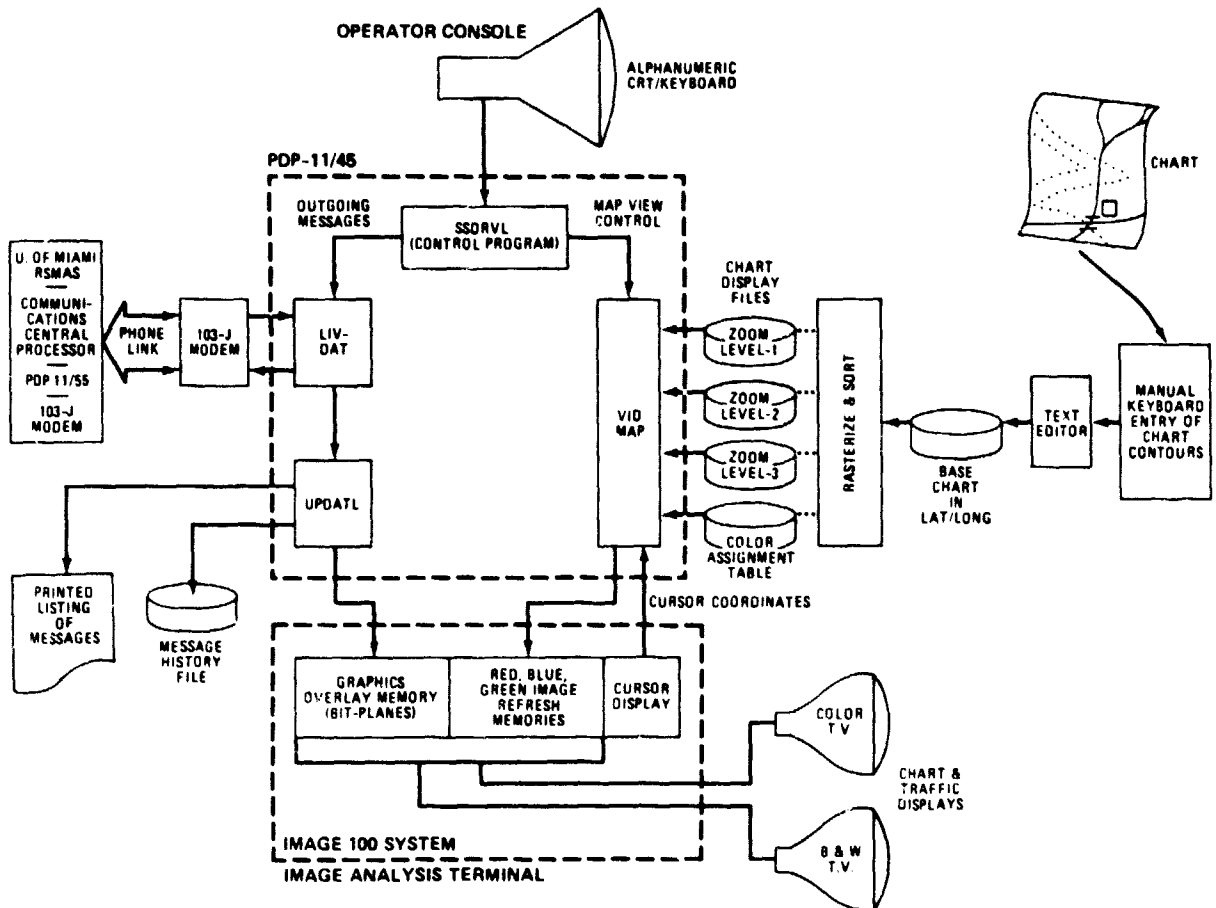

FIGURE 17: Control Center Chart Generation and Display Processing

### 3.0 PRELIMINARY TESTS

The Rosenstiel School of Marine and Atmospheric Sciences (RSMAS) in Miami, Florida, conducted a series of extensive tests in a back-to-back configuration of the complete system (except for the video display system and the teletype). Miami's main concern was the modification of the system to

automatically interrogate the LORAN-C receiver data. The new computer program on the PDP-11/55 automatically interrogated the LORAN-C receiver once per minute using the ATS-3 communications link. Of course, the LORAN-C receiver was in the same building as the Control Center so that the position did not change. It was difficult to get a good fix because of the geometry of the LORAN stations. Finally, RSMAS procured a new pair of read-only-memories (ROMs) for a new LORAN-C chain which became operational after the LORAN-C receiver was developed. Once the LORAN-C was working satisfactorily, then the test permitted the "debugging" or "checking-out" of the computer software. When the computer program and equipment were working well, the first phase of RSMAS' development and test were complete.

Following the tests at RSMAS, the US Coast Guard suggested the need for an addition to the system capabilities for automatic message transmission from ships on request. Specifically, the USCG desired ship manifests at least 24 hours prior to arrival in port, and search and rescue operations reports approximately every hour. In response to this request, a teletype BSR-4340 unit was added to the system following modification of the CCP and the computer software. From RSMAS, the 350-watt, RF power amplifier, CCP, LORAN-C receiver, and Clegg transceiver were shipped to the Eden Laboratory at Malabar, Florida. Tests began with the simulated ship location at Malabar.

The RTU at Malabar initiated the automatic acquisition program on the RSMAS' PDP-11/55 computer. Automatic interrogation of the LORAN-C receiver and the BSR-4340 teletype began with the LORAN-C sensing data

once per minute for four minutes and the teletype buffer sensing its messages on the fifth minute. The new address and polling routines were checked out, changes made, and re-tested.

When the integrated system was operating satisfactorily for several hours per day, the data which was retrieved and stored on tape at RSMAS was played back to Malabar via ATS-3 for analysis. Several days of continuous satisfactory operation at Malabar completed these integration tests.

#### 4.0 TESTS ABOARD SLOOP

The next phase of tests took place dockside at Sherwood Forest, Maryland. The equipment was installed on the sloop "Sunshine," connected, and operated dockside using shore power initially, and then using the on-board generator. Malabar's RTU initiated RSMAS' automatic interrogation program. The equipment responded as it had in Malabar. The major difference was the new antenna. After correcting a grounding problem, tests on the LORAN-C receiver were successful. The data were played back to "Sunshine" after two days of nearly continuous operation. Appendix B shows a portion of the print-out of these tests.

To test the integrated system, particularly the antenna, several tests were run underway in the Severn River and the Chesapeake Bay near Annapolis, Maryland. The sloop was put through several sharp turns and allowed to roll in the troughs of wakes of ships. The antenna system worked well with no significant loss of signal. After each test, the data were played back from RSMAS via ATS-3 for examination. It became apparent during these tests that some bias corrections would have to be used when the vessel track was to be displayed on the video monitor.

Initial checkout of the system aboard the sloop exposed some minor problems. Inability to gain good position fixes was due both to inadequate grounding of the LORAN-C receiver chassis and to RF interference both internal and external.

Fiberglass hulled crafts today can readily solve the problem of good ground by imbedding a large bronze plate in the hull. This plate is "faired in" with the hull and is usually done when the craft is under construction. Otherwise fibercraft are hauled and one, usually two, porous bronze shoes are fixed to the outer hull below the waterline and through-bolted to the inside of the hull for strength and electrical connections.

As an expedient, a 1.2 meter (4-foot) length of copper tubing was clamped to the end of a long grounding strap and trailed in the water. With the LORAN-C receiver chassis connected to this grounding system, the position data was excellent except in the presence of RF interference.

Internal interference came from several sources when the system was operating from on-board power. At the dock, with only the generator running, some electrical noise was attributed to the generator itself. Engineers at the Onan Generator Company indicated that the source of this interference was in the "bell" housing. This problem was that the four pick-up brushes and a set of points created the common electrical noise and the spark suppression components had gotten out of adjustment. The bell housing was inaccessible unless the entire generator was hoisted out. This would have been a major effort. The generator interference



was overcome by adding a one microfarad capacitor across the 110V output terminals and shielding the generator with wire screen. The small 12 VDC fans produced considerable electrical noise and these subsequently, were not used during tests.

After solving the RFI problems at the dock with only the ONAN generator running, tests were conducted underway with the main engine and the ONAN generator in operation. Again, there was electrical interference from the main engine alternator. As a further expedient, the field coil was disconnected permanently and all battery charging was done with the ONAN generator.

External RFI was most severe when the testing occurred within a few miles of the Naval Sending Station (NSS) at Annapolis. The LORAN-C receiver would not lock up due to the low signal to noise power when that station was broadcasting. Apparently the NSS transmits at 88 kHz, or higher, at a radiated power of 10 megawatts. Filter circuits between the antenna front end and the receiver were attempted to reduce the interference, but these were unsuccessful. The president of Micrologic suggested that the LORAN-C antenna be shortened from ten to two feet and that two of the four notch filters on the receiver be put on to the 88 kHz interfering frequencies. These measures helped significantly. If there had been sufficient time, the Micrologic Corporation, was willing to design special preamps for the RF front end which would also have reduced the extent of interference getting into the receiver.

There were occasional periods of substantial interference during check-out and setting up for tests while still at dockside in Little Creek Harbor and its environs. This appeared to have been due partly to a search radar -- either experimental or operational. Marine Electronics Consultants, Inc., in Chesapeake, Virginia, were consulted. This company acknowledged that there had been some interference affecting the LORAN systems in the area of Little Creek and Hampton Roads areas, and that several users had complained about the erratic behavior of their own LORAN-C receivers. In the Thimble Shoals Channel (Chesapeake Bay) and surrounding area, there were no local interference problems.

## 5.0 EXPERIMENTS

### 5.1 TEST AREA

Collisions and groundings of vessels occur often in coastal regions where the traffic density is greatest. In these territorial waters, safe passage is further aggravated by navigational hazards such as underwater topography, strong currents, obstructions, and fog. There are several confluence regions on the US East Coast where collisions and groundings have occurred. The lower Chesapeake Bay region, including its entrance, was selected as the test area because of the large volume of ship traffic, its typical hazards, and proximity.

A 69.1 X 55.9 kilometer (43.6 by 34.8 statute-mile) rectangle (38 minute X 38 minute arcs of latitude/longitude) of the test area was transferred from a nautical chart to a video color display at GSFC. In order to display the essential features of the nautical chart on the color video monitor, it was necessary to determine the latitude and longitude of

each buoy and the point of inflection of each straight line from the chart. For example, the shoreline and water-depth contour lines were divided into several small, straight-line segments and the latitude and longitude of each of their end points were obtained from the chart. In a similar way, the bridge and tunnel complex, spoil areas, pilot boarding areas, and caution zones were transferred. Once the location and bounds of the desired features of the nautical chart were defined by latitude and longitude, it was a straight-forward process of transferring these data to computer software and filing them on a magnetic disk. Three levels of magnification were provided with the highest level having a resolution of 34.4 meters (113 feet) per picture element (pixel). At the higher magnification levels, the section of the chart to be magnified and displayed is selected by the operator using a joystick-controlled cursor.

#### 5.5.1 June 1979 Test

The first operational experiment in the lower Chesapeake Bay test area was conducted in June 1979. The purpose of the tests was to become more familiar with the test area and to determine what geographical location biases might be needed to keep the vessel within the buoy-channel markers on the video display. Tests were conducted over a two-day period with course runs across the test area and in the channels. Some interference was experienced in the Little Creek Harbor which made adjustment of the LORAN-C receiver notch filters more difficult. Ship position data was recorded at RSMAS and later transmitted to the Satellite Image-100 Processing Facility video display and computer system located at GSFC.

The ship position fixes received at the RSMAS were superimposed upon the computer-driven map on the video color screen at GSFC where the vessel's progress could be traced. The display at GSFC showed the test area with all essential features in color and, for the first time, the record of the vessel track as it has proceeded on various courses several days before.

#### 5.5.2 August 1979 Test

A second series of experiments in August 1979 were made along the edge of the three major channels; Thimble Shoal Channel, York River Channel, and York Spit Channel. The purpose of these tests was to obtain more data within the channels and set bias corrections as necessary. As in the earlier June 1979 tests, data was obtained automatically by RSMAS on command from Malabar, recorded, and sent by landline to GSFC. (A permanent record of these runs could be rerun or filmed for any convenient chart scale and replay speed.) Analysis of the data showed that it was necessary for the Goddard controller to introduce a longitude correction of 20 seconds of arc in a westerly direction to place the vessel track within the channel. This correction, corresponding to approximately 457.5 m (500 yards), was the only one made which remained constant for nine hours of continuous operation. No bias correction was necessary in latitude.

Figures 18 through 20 are photographs of the video display during the August 1979 experiment.

Included in the first of the sequence is Cape Henry to the south with Lynhaven Bay to the left and Norfolk to the far left. The Bay Bridge

and Tunnel complex is depicted by the heavy black line broken only by the tunnels which pass beneath Thimble Shoal Channel and the Northern Channel which is the central portion of the bridge span. One can discern the underwater topography, with the light shaded portion being greater than 10.97 meters (6 fathoms) the medium shade representing depths between 9.14 and 10.97 meters (five and six fathoms) and the darker portion being less than 9.14 meters (five fathoms). Channel buoys and obstruction markers are denoted by the white dots, while the trapezoid pilot boarding areas and circular precautionary zone are denoted by white dashes. Willoughby Tunnel, over which the channel enters Hampton Roads, is shown at the far left center of the picture. At the far right is a fiducial cross which can be moved to any area by joy-stick-cursor control to enlarge a section of interest for closer examination and control. The rectangular areas adjacent to the York River Channel and the York Spit Channel at the upper left are dredging spoil deposit areas. All of the above features are contained in the computer data base to which the computer superimposes the real-time action of the vessel motion.

The photograph was taken while the test vessel was moving. The vessel track, the black line on the right side of the channel, becomes a permanent record which can be replayed at anytime and with the desired collapsed time. The vessel began its test run at the southeast end of the York River Channel and proceeded to the northwest end while keeping within 7.62 meters (25 feet) of the right hand line of buoys. At the northwest end, the vessel turned and headed east-northeast a distance of 14.4 kilometers (9 miles) to the north end of the York Spit Channel which

provides passage to the deep water leading northward to Annapolis, Baltimore, and the C&D Canal. The vessel entered the channel proceeding southward following the right hand line of buoys at a distance of about 7.62 meters (25 feet). The photo was taken just as the test vessel, denoted by the center of the arrowhead, was leaving the channel and heading for the North Tunnel of the Bay Bridge.

Figure 19 shows a larger scale display of the test vessel which has just passed over the southern side of the North Tunnel. The curve in the vessel track was caused by a course change initiated to avoid collision with the bridge north of the tunnel. The "Sunshine" came alongside the last buoy to the south and made a 90° left turn before crossing over the tunnel.

Figure 20 shows an even larger scale display of the test vessel track. The vessel has crossed over the North Tunnel and turned south to the eastern end of the Thimble Shoal Channel. The arrowhead represents the corrected LORAN-C position of the vessel whose ship identification code was "BKR."

#### 6.0 LOWER CHESAPEAKE BAY FINAL DEMONSTRATION

Demonstrations of this satellite-aided vessel traffic monitoring system were conducted October 11 and 12, 1979. Representatives from several U.S. Government agencies were present at GSFC to observe the color video monitor. Teletype messages and computed speed, as well as the test vessel track were displayed on the screen. Most of the teletype messages were simulated manifests and prearrival messages from a large cargo ship.



FIGURE 18: Video Display of Test Area - Zoom Level 1

ORIGINAL PAGE IS  
OF POOR QUALITY

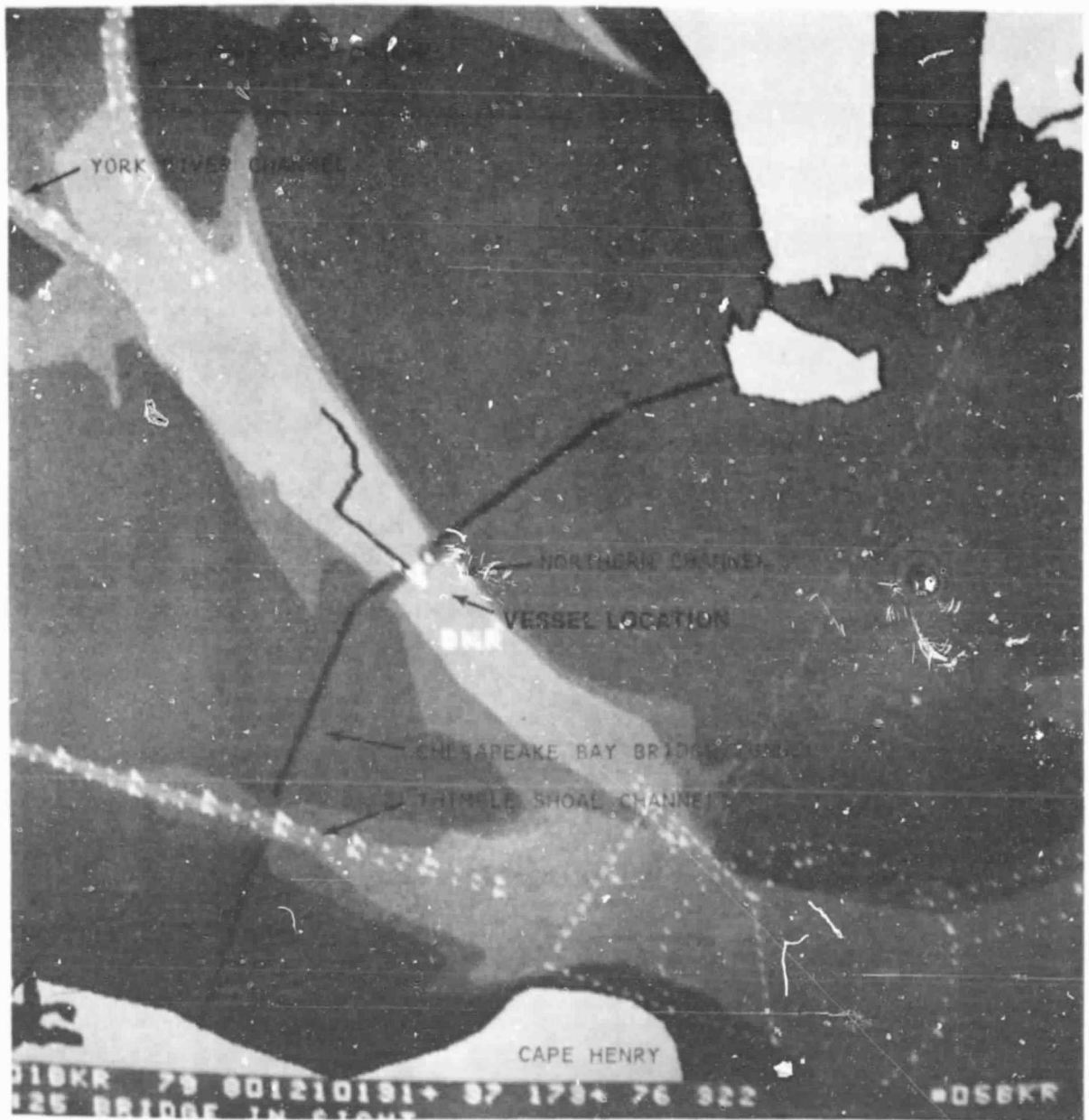

FIGURE 19: Video Display of Test Area - Zoom Level 2



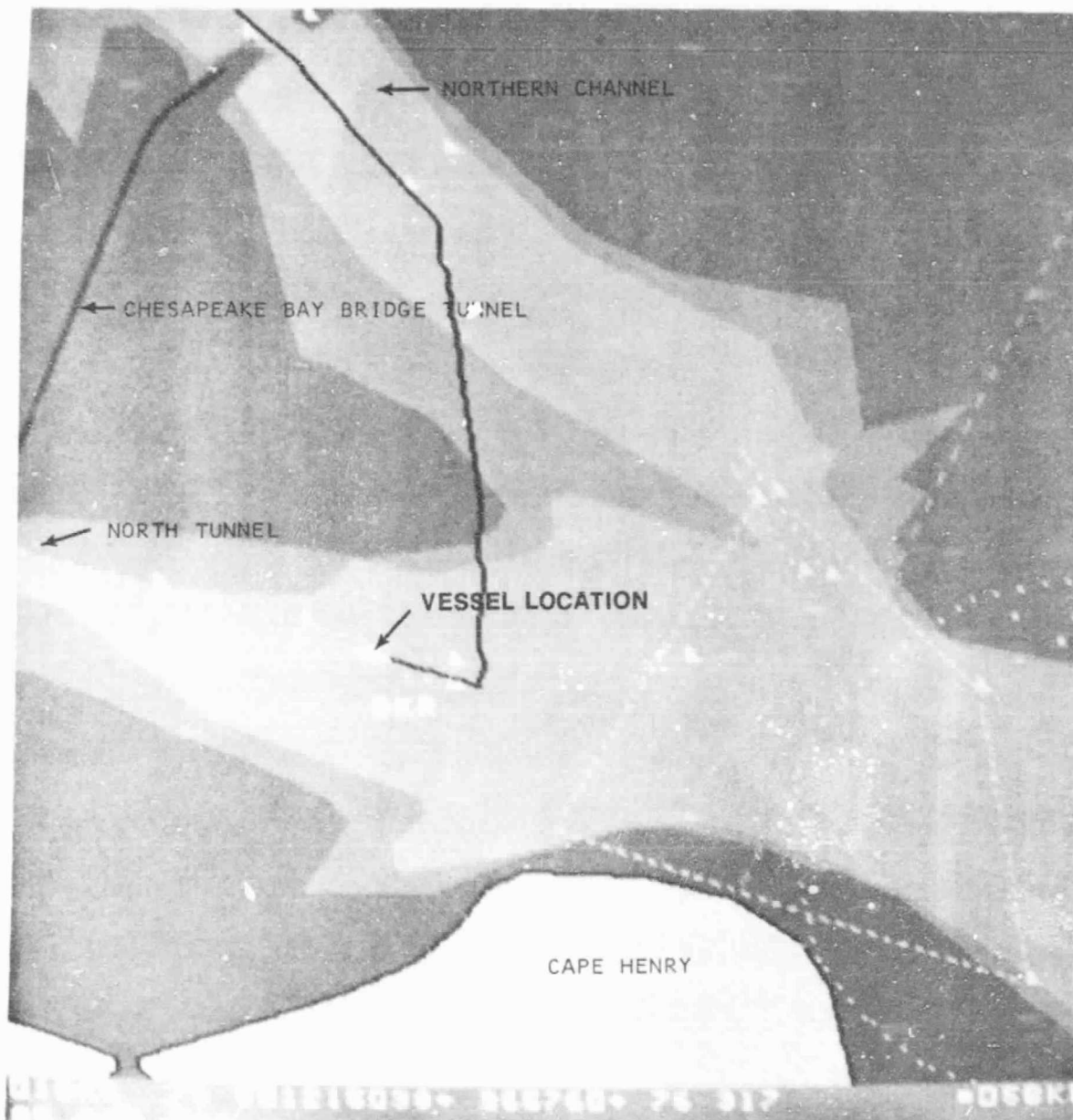

Figure 20: Video Display of Test Area - Zoom Level 4

On October 11, 1979, the two-hour period of demonstration was conducted in the York River Channel. Courses were changed periodically and messages entered into the teletype buffer and transmitted to Goddard via ATS-3. Figure 21 is a typical portion of the printout at the vessel during the demonstration.

The demonstration of October 12, 1979, lasted four hours and was conducted in the vicinity of the Thimble Shoal Channel. Many messages were transmitted from and received by the test vessel, and the "controller" at GSFC ordered numerous changes of course and speed. Periodically, positions were played back to the vessel. These demonstrations were very successful and no equipment malfunctions occurred.

```

A+12OCT79134321BKR 50^ HELLO FROM THE SLOOP SUNSHINE^ WE HAVE V
A+70ERY GOOD CRUISING WEATHER TODAY.^ WIND APPROX. 15 KT. SEAS 1-2 F
A 46^ PLENTY OF SUN TODAY.^ BALMY CLEAR.^
L 12OCT79134341BKR 22+ 36 59.21 + 76 14.31
L 12OCT79134412BKR 22+ 36 59.27 + 76 14.32
A+70E: 030 MAG^ SPEED: 1600 RPM^ PYROMETER: 725 F^ WIND : 17
A 37.^ SEAS: 2 FT.^ TIME: 1340 L^
L 12OCT79134539BKR 22+ 36 59.49 + 76 14.24
L 12OCT79134642BKR 22+ 36 59.58+ 76 14.22
L 12OCT79134751BKR 22+ 36 59.74 + 76 14.17
L 12OCT79134822BKR 22+ 36 59.80 + 76 14.17
A+12OCT79134921BKR 50^ DESTINATION: BALTIMORE^ CHANNEL MAJ^
A+70 BEDMWB3g+n.^CYTR`e`"0! ESTIMATED TIME OF ARR. AT CHANNEL MARKER:
A 57 12 1200N 13 OCT 1979^ CARGO: GENERAL^ OFFLOAD
A 578E CHANGE: 100 MAG^ SPEED: 1500 RPM^ TIME:1345 L^
L 12OCT79135232BKR 22+ 37 0.03 + 76 13.70
L 12OCT79135342BKR 22+ 37 0.04 + 76 13.51
L 12OCT79135412BKR 22+ 37 0.04 + 76 13.45
A+12OCT79135519BKR 50^ FROM THE DECKS OF THE SUNSHINE: SEAS
A 44^ HOLD ON HERE COMES A BIG WAVE!!!!!!^
L 12OCT79135539BKR 22+ 37 0.03 + 76 13.21

```

FIGURE 21: Typical Teletype Printout

## 7.0 RESULTS OF DEMONSTRATIONS

### 7.1 LORAN-C NAVIGATION SYSTEM

On October 11, 1979, the first demonstration test voyage was run parallel to the line of channel buoys marking the entrance to the York River. The course was 310°T approximately 22.9 meters (25 yards) outside of the channel. On reaching buoy R "18" the heading was reversed and the test run proceeded south easterly, again maintaining a position approximately 22.9 meters (25 yards) outside of the channel. LORAN-C position data from the computer printout was subsequently plotted on Nautical Chart #12221.

The offset distance between the actual course and the track provided by LORAN-C positions was between 480.3 and 503.2 meters (525 and 550 yards). This track offset error was typical throughout the demonstration of October 11 and October 12, but was 22.9 to 45.7 meters (25 to 50 yards) greater than during the earlier experiments. Although some error may be attributed to the LORAN-C receiver and computation system, the extent of position offset is of a similar magnitude experienced by other LORAN-C users in the lower Chesapeake Bay.

The vessels track history shows that, although offset, position error was constant and the tracks were exactly parallel to the channel. The LORAN-C MICROLOGIC-1000 NAVIGATOR functioned very satisfactorily.

### 7.2 ROLL CALL TECHNIQUE

This approach, simulating 50 vessels, performed well for acquisition of vessel position and prearrival messages. The simple address system

could accommodate the entire international fleet using only two seconds per interrogation. The roll call approach also has the advantage over the fixed time slot of flexibility in being able to vary the time interval between successive position or message interrogation and message length.

### 7.3 DISPLAY SYSTEM

The color video display was superior to the black and white because an operator can more readily differentiate the color coded depths and underwater obstructions. The video display of the nautical chart with vessel positions superimposed was detailed, very accurate, and easy to follow.

### 7.4 COMMUNICATIONS

The satellite communications link performed well with a carrier-to-noise ratio of 2.5 dB. The data system modulation, logic system and selection of frequencies all yielded excellent results.

On the October 12th demonstrations, some data were lost for a few seconds when the antenna was not pointed toward the satellite. Approximately 26 course changes were made during the four hour period. The antennas were limited in azimuth to  $365^{\circ}$  so that, occasionally, they had to be rotated through  $360^{\circ}$  in order to point to the ATS-3 satellite and it was during these several-second occasions that data was not retrieved.

## 8.0 CONCLUSIONS

### 8.1 SYSTEM ADVANTAGES

Unlimited Range: The existing ATS-3 is located at a subsatellite point of  $105^{\circ}$  west longitude and covers the East and West coast of the United States, the Gulf of Mexico, Caribbean, and most of Alaska.

- Many US and foreign vessels already have LORAN-C which provides essential coverage of the 321.8 km (200-mile) zone and more transmitting stations are planned.
- Both computer and operator can make independent assessments of critical situations as they develop.
- The vessel track history is a permanent record and can be brought up for instant replay and analysis.
- Any navigation system which is sufficiently accurate, and having the appropriate electrical interface, can be used such as LORAN-A, TRANSIT, OMEGA, DECCA, GPS, Inertial Guidance.
- The system is operable in any kind of weather.
- Shipboard installation is relatively inexpensive, because the technology has been developed.
- Data is formatted in accordance with the American Standard Code for Information Interchange and the electrical interface of equipment is compatible with RS-232 (an EIA Standard). This permits information to be transmitted from ships and control centers easily to any part of the United States and its possessions using existing commercial equipment.
- Data from this advanced experimental program would provide a viable data base for a commercial operational system at an earlier time.

- Using the synchronous detection scheme with the PCM data, a very high signal-to-noise ratio (S/N) is achieved without the need for precision oscillators and phase locked loops in the transmitter or receiver.

## 8.2 MULTIUSE CAPABILITIES OF SYSTEM

Search and Rescue: This system would permit search vessels, review boards and control centers to "see" the actual track and search pattern of the cutter or other Coast Guard rescue vessel. Periodic search reports could be entered into the teletype buffer and be available in a video monitor and in print within seconds after interrogation. At the scene, all information concerning the emergency would be available.

Ships Entering Territorial Waters: In view of the number and seriousness of accidents, the USGS, Environmental Protection (EPA), NOAA, and MARRAD are concerned with the large oil tankers and other hazardous cargo carriers which intend to enter deep water ports or inland waters. It would be helpful to have ship manifests retrieved automatically as ships enter the 321.8 km (200-mile) limit. This would reduce delays in inspection and preparation of additional safeguards if required.

Coastal Zone Management: This system could improve the knowledge of presence and location of U.S. and foreign commercial and fishing vessels in territorial waters and provide traffic advisory data in certain confluence regions.

Avoidance of Collisions and Groundings: In treacherous confluence areas not covered by radar control or near shoals or obstructions offshore,

the ability to "see" the development of a potential collision or grounding would aid in preventing an accident.

Military: The system has the capability to "see" war game tactical maneuvers far at sea and observe each vessels position and track as it is happening and it should be of value to be able to provide instant replay for subsequent analyses.

In a similar manner, the system would be of use in long distance target practice at sea. During hostilities, the system would be of use in monitoring ships positions within convoys. The system's potential applications encompasses all of the above. Its value during a crisis situation would be inestimatable.

Research and Exploration: Value would be in having an on-shore record of ship's position at all times.

## REFERENCES

1. Anon, "How Effective is the Coast Guard in Carrying Out its Commercial Vessel Safety Responsibility?" Report No. CED-79-54, US General Accounting Office, Washington, DC, May 1979.
2. Anon, "Coast Guard Action Needed to Promote Safer Marine Transportation," Report No. CED-79-37, US General Accounting Office, Washington, DC, May 1979.
3. "Vessel Monitoring Systems Study," Transportation systems Center, Final Report, CG-D-52-80.1, September 1980.
4. "Communications Requirements for a LORAN-C Position Monitoring System for VTS Valdez, Alaska," T. M. Drown, Office of Research & Development, US Coast Guard, Washington, DC, Report No. CG-D-36-80, June 1980.
5. Memorandum of Understanding between The State of California and National Aeronautics and Space Administration, Edward Brown, Governor of California, Robert Frosch, Administrator, NASA, November 22, December 20, 1977.



## ACKNOWLEDGEMENTS

Rosenstiel School of Marine and Atmospheric Sciences, University of Miami, 4600 Rickenbacker Causeway, Miami, Florida, for development and test of the LORAN-C receiver interface electronics, the command generation and data retrieval, software for the PDP-11/55 and the use of their terminal equipment for operating with ATS-3 during all experiments, tests, and final demonstrations.

Mr. Paul Eden, Eden Labs, Corey Road, Rt. #2, Malabar, Florida, for development of the Communication Central Processor, the integration of the BSR-4340 teletype, and test of the complete system in back-to-back configuration at Malabar, and his support of many hours of testing at dockside and in the Chesapeake Bay.

Mr. Mel Banks, Jr., Engineer, Goddard Space Flight Center, Code 933.1, Greenbelt, Maryland, for development and test of chart generation and video display software programs and support of all experiments underway and final demonstrations.

Mr. Charles Cote, Head, User Terminal and Locations Systems Branch, Code 945, Goddard Space Flight Center, Greenbelt, Maryland, for continued support of this project and related work.

Capt. Roger S. Betts, USN, Norfolk, Virginia, for donating the use of his Columbia-45 sloop, "Sunshine," for all testing and demonstrations dockside and underway.

Mr. Ralph Taylor, Engineer, User Terminal and Location Systems Branch,  
Code 945, Goddard Space Flight Center, Greenbelt, Maryland, for the  
coordination and implementation of the NASA/Goddard portions of this  
combined effort.

**APPENDIX A**

**VESSEL TRACKING DISPLAY**

**AND**

**DATA SYSTEM**

**Melvin Banks, Jr.  
Goddard Space Flight Center  
Greenbelt, Maryland**

**James Brown  
Rosenstiel School of Marine  
and Atmospheric Science  
University of Miami  
Miami, Florida**

## APPENDIX A

### VESSEL TRACKING DISPLAY AND DATA SYSTEM

Melvin Banks, Jr.  
Goddard Space Flight Center

and

James Brown  
University of Miami

#### 1.0 INTRODUCTION

This appendix describes the control center, communications, message processing, data base, and image display software for the coastal zone monitoring and offshore vessel tracking and display system. This system was developed cooperatively by the Information Extraction Division of the Goddard Space Flight center, Greenbelt, Maryland, and the University of Miami Rosenstiel School of Marine and Atmospheric Science (RSMAS) in Miami, Florida. The Goddard effort centered on developing the image display and plotting software and the communications protocol for RSMAS Miami/Goddard data transmission. The University of Miami effort centered on developing the ship communications protocol, message handling, and data-base software.

#### 2.0 OVERVIEW

The basic functions of the Vessel Tracking System Control Center are:

- Tracking of vessels at sea by plotting their positions on a television-displayed navigational chart, from latitude-longitude fixes transmitted at regular intervals from the vessels. The positions are plotted in near-real time; that is, essentially

the actual time at which the positions were determined on board the vessel.

- Providing two-way text message communication between the vessel and the central tracking and display terminal.
- Storing, on computer disk, the history of each tracking session for playback and review.

Figure A-1 shows the overall system configuration. Vessel tracking and display is done at GSFC using position messages relayed from the vessel through Miami. Text messages are similarly relayed between GSFC and the vessel through Miami. Messages outgoing to the vessel are entered at the GSFC tracking and display terminal, sent to Miami, then to the vessel. Messages from the vessel are received by Miami then sent to GSFC where they appear at the bottom of the television chart display. Miami acts as a message switching center, interfacing with both GSFC and the vessel's communications protocols and synchronizing all message exchanges between them. Miami also maintains a log file of all text messages and position records exchanged. A limited log file is also maintained at GSFC for playback of each tracking session.

The GSFC and Miami functions could have been consolidated into a single computer at a single control center location. The present system was developed at separate locations to reduce costs and take advantage of the existing equipment, software, and expertise available at the different sites.

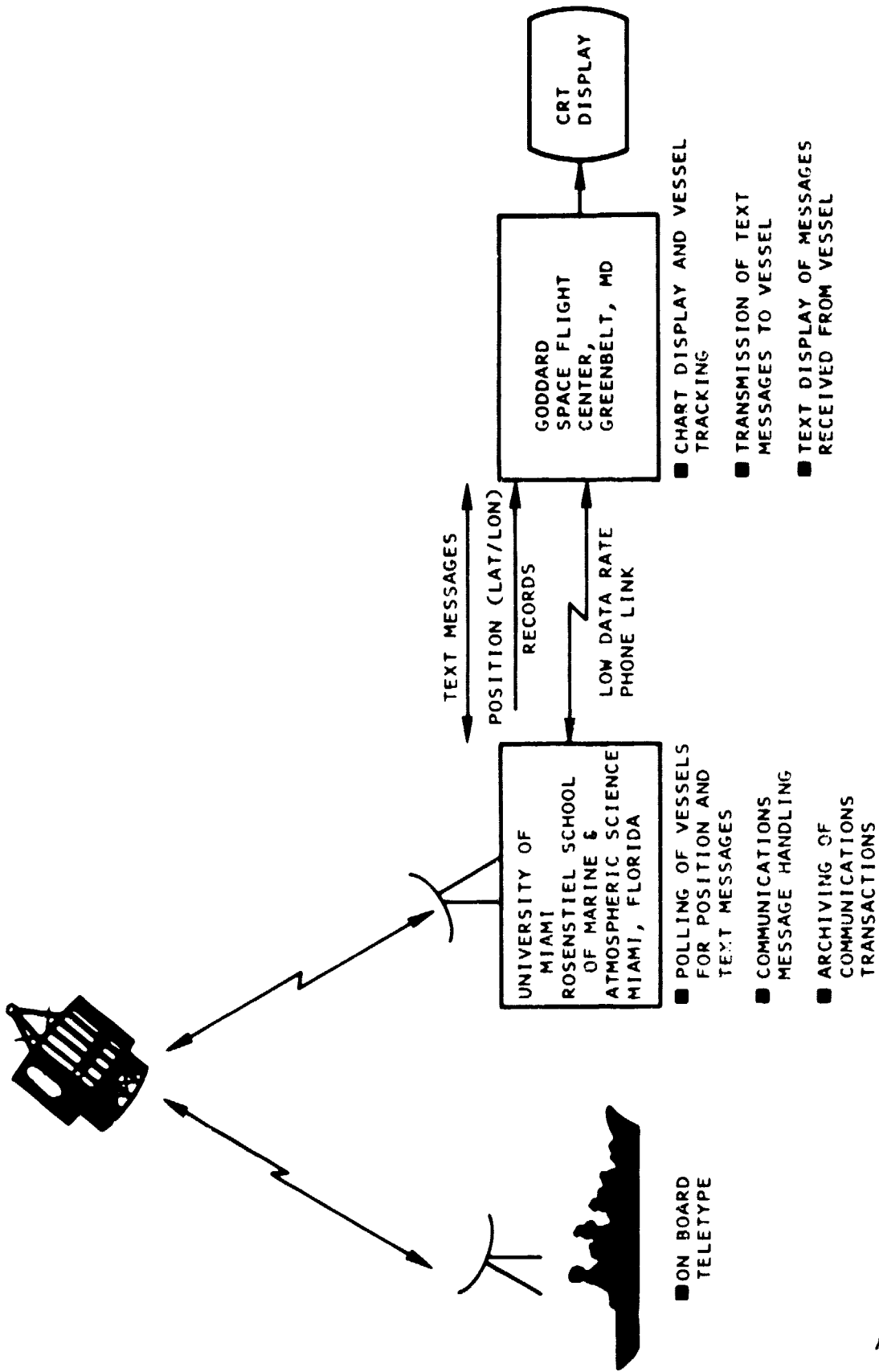

FIGURE A-1: Functional Overview of Ship Tracking and Display System

### 3.0 TRACKING AND DISPLAY AT GSFC

#### 3.1 COMPUTER FACILITIES

This software was developed on the existing Atmospheric and Oceanographic Information Processing System (AOIPS) at GSFC, and utilizes the AOIPS PDP-11/70 and PDP-11/45 computers and the GE Image 100 image analysis display terminal. The AOIPS facility is described fully in GSFC X-933-77-145.\*

Although the ship monitoring and tracking software described herein was implemented using two computers, a single-computer configuration would be sufficient. All run-time processing is done on the PDP-11/45; the PDP-11/70 is used offline in a support mode for software development, and for rapid building and sorting of large image files. Reasons for this are: (1) the PDP-11/45 is part of a turnkey image analysis system (the GE Image 100) and has little time available for development, and (2) the PDP-11/70 is faster for large sorts. Both computers run under the RSX-11D operating system.

#### 3.2 SOFTWARE SYSTEM

The software system consists of two major subsystems. Refer to Figure A-2. The map generation subsystem creates disk files containing television images of the desired map (in this case the mouth of the Chesapeake Bay) at various magnification scales, or zoom levels. The display processing subsystem transfers the disk images to the color display

---

\*Atmospheric and Oceanographic Information Processing Systems (AOIPS) System Description; P. A. Brachen, J. T. Dalton, J. B. Billingsley, J. J. Quann, GSFC Document X-933-77-145, March 1977.

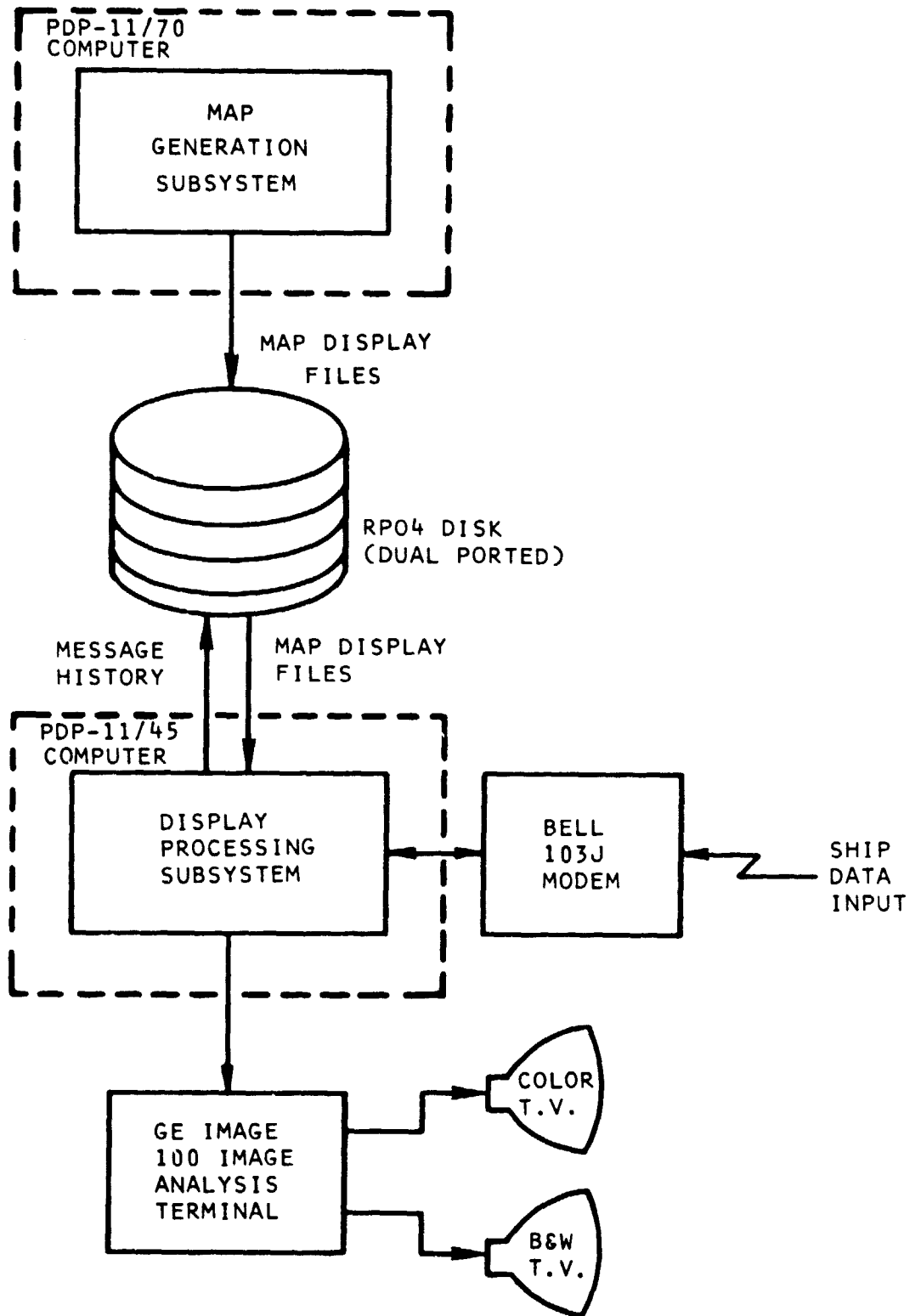

FIGURE A-2: Ship Survey System Overview



terminal, and simultaneously plots ship position and displays text messages received from the ship. Map images are created on the PDP-11/70 and stored on a dual-ported disk which is then switched to the PDP-11/45 for run-time access.

### 3.2.1 Map Generation Subsystems

The map images are generated as follows (refer to Figure A-3):

1. Map features to be displayed are first identified and assigned an ID code. Colored areas, e.g., land areas and water areas of constant depth, must be defined by closed polygons. Segmented lines may be used to define such non-area features as channel boundaries, bridges, etc. The latitudes and longitudes of all polygon corners and line breakpoints are then manually entered into the computer via a standard text editor, along with their corresponding ID codes. A base map in latitude-longitude is created on disk.

2. The program BLDSCAN is then used to "rasterize" the latitude-longitude map, i.e., convert it to an n by m matrix of image points, where each point of the matrix contains the ID code of the map feature at that location. The choice of n and m determined the magnification scale or zoom level. Each image point, or pixel value, is assigned an X, Y grid location and an ID code.

3. The program SORTSCAN sorts the pixels by Y (image raster line number) and X (pixel location within the line). At the same time the raster lines are compressed to eliminate repetition of consecutive pixels

of equal value. The format of the resulting image file is shown in Table A-1.

TABLE A-1

Line Number	Compressed Line Contents
1	(ID <sub>11</sub> )(NPIXLS <sub>11</sub> )(ID <sub>12</sub> )(NPIXLS <sub>12</sub> ).....(ID <sub>1j</sub> )(NPIXLS <sub>1j</sub> )
2	(ID <sub>21</sub> )(NPIXLS <sub>21</sub> )(ID <sub>22</sub> )(NPIXLS <sub>22</sub> ).....(ID <sub>2j</sub> )(NPIXLS <sub>2j</sub> )
.	.
.	.
.	.
n	(ID <sub>n1</sub> )(NPIXLS <sub>n1</sub> )(ID <sub>n2</sub> )(NPIXLS <sub>n2</sub> ).....(ID <sub>nk</sub> )(NPIXLS <sub>nk</sub> )

In the above format, ID is the ID code of an area or line, and NPIXLS is the corresponding repeat count, or number of consecutive occurrences of ID. The sum of NPIXLS for each line must equal m, the number of pixels per line. Note that actual X and Y grid locations are dropped from the final image file.

The mouth of the Chesapeake Bay was mapped at three zoom levels for the demonstration system. Specifications for each zoom level are given in Table A-2.

TABLE A-2

Zoom Level	Total Map Range (kilometers)	Grid Size	View Window Size (kilometers)	Height, Width One Pixel (meters)	Disk Space Required Bytes
1	69.7 X 55.4	512 X 512	69.7 X 55.4	50.2	54K
2	69.7 X 55.4	1024 X 1024	35.8 X 27.9	20.8	111K
3	69.7 X 55.4	2048 X 2048	17.5 X 13.9	10.4	218K

### 3.2.2 Display Processing Subsystem

Refer to Figure A-4. The run-time system consists of a communications module (LIVDAT), a position and message processing module (UPDATL),

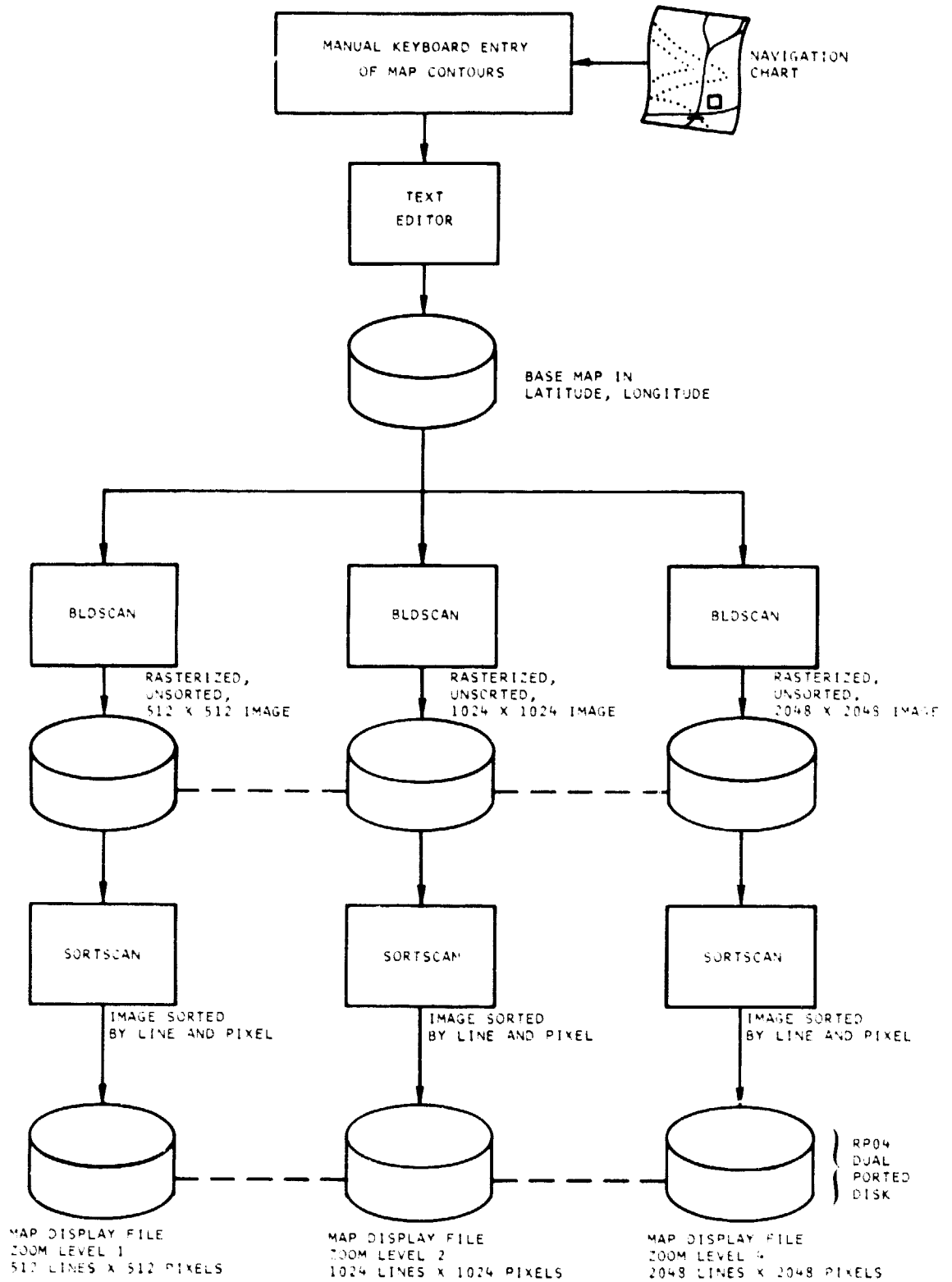

FIGURE A-3: Map Generation System (PDP-11/70 Computer)

and an image display module (VIDMAP). All modules run as independent tasks under the RSX-11D operating system. The driver, or control task (SSDRVL) provides operator control of the system.

Communications is via a Bell 103J, 300 baud dial-up modem connected to an asynchronous terminal interface on the PDP-11/45. I/O is done through the standard terminal driver of the RSX-11D operating system using QIO (Queue I/O) requests. All data is in the form of ASCII character strings. (See Table A-3).

The communications sequence is as follows:

1. GSFC sends message (if operator has entered any) to Miami to be routed to ship.
2. GSFC polls Miami with request for any new ship messages.
3. If Miami has no new data available, it responds with "no data". GSFC then repeats (1), and (2) at timed intervals.
4. If Miami has new data, it sends out one record, then waits for the next poll from GSFC.
5. GSFC processes the record, then goes to (1).

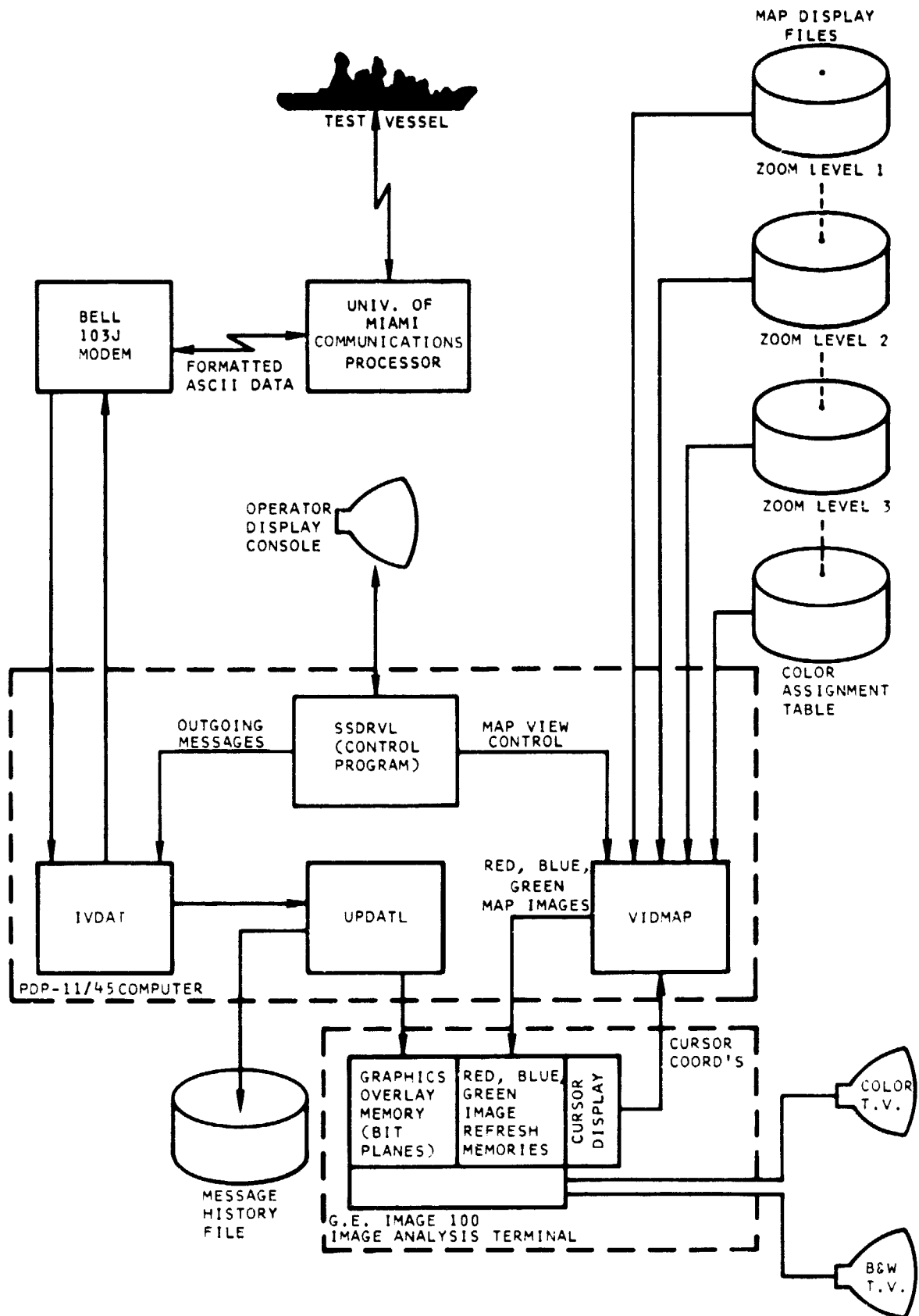

FIGURE A-4: Display Processing Subsystem (PDP-11/45 Computer)

TABLE A-3

GSFC-Miami Communications Formats

(All records are ASCII character strings, 8 bits per character. All records are followed by the carriage return character.)

1. "No data" response from Miami:

Byte No. - 1 2 3 4  

#	0	0	CR
---	---	---	----

  
 Record Type

2. Vessel Position Record:

Byte No. - 1 2 3 4 5 6 7 8 9 10 11 12 13 14 15 16 17 18 19 20  

#	0	5	A	A	A	A	A	Y	Y	M	M	D	D	H	M	M	S	S
---	---	---	---	---	---	---	---	---	---	---	---	---	---	---	---	---	---	---

	Record Type	Vessel ID		Date & Time
				(Year, Month, Day, Hour, Minute, Second)

Byte No. - 22 23 24 25 26 27 28 29 30 31 32 33 34 35 36 37  

+/-	N	N	N	N	N	N	N	+/-	N	N	N	N	N	N	N	CR
-----	---	---	---	---	---	---	---	-----	---	---	---	---	---	---	---	----

Signed Latitude	Signed Longitude
-----------------	------------------

Latitude and longitude formats are as follows:

DDMMHH

where, DDD = degrees  
 MM = minutes  
 HH = hundreds of a minute

3. Byte No. - 1 2 3 4 5 6 7 8 9 10 11 12 13 14 15 16 17 18 19 20  

#	0	7	A	A	A	A	A	Y	Y	M	M	D	D	H	H	M	M	S	S
---	---	---	---	---	---	---	---	---	---	---	---	---	---	---	---	---	---	---	---

	Record Type	Origin ID		Date & Time
				(Year, Month, Day, Hour Minute, Second)

21 22 23  

A	A	A	.	.	.	.	CR
---	---	---	---	---	---	---	----

  
 1 - 59 Characters of Text

4. Request for data:

Byte No. - 1 2 3 4  

#	0	6	CR
---	---	---	----

  
 [Record]  
 Type

5. Message to or from Miami (not routed to vessel):

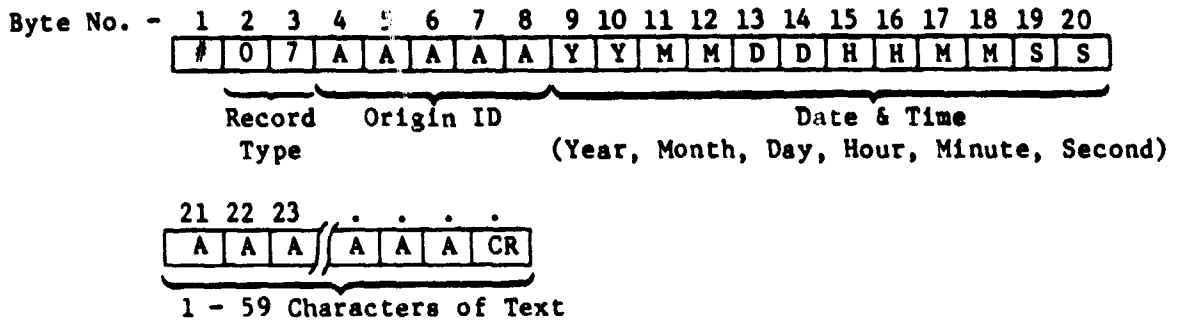

3.2.2. Position and Message Processing

The task UPDATL is activated by the communications task LIVDAT each time a data record is received from Miami. The record is passed to UPDATL where it is processed and displayed. Record processing proceeds as follows:

1. Verify that the record type code is either 01, 05, 04 05 (see Table A-3). Reject all others.
2. If record type is 05 or 07 (text message), display the message at the bottom of the color map display, then exit. No error processing is performed.
3. If record type is 01 (position), check the time and position fields for valid characters and legitimate values. Time must increase; positions must be within map ranges; etc.
4. Display the position record at the bottom of the color map display.
5. Convert the latitude and longitude to a grid location (line and pixel numbers) relative to the map view that is currently being displayed on the color screen.

6. Plot the new position of the vessel on the screen, then exit. The vessel is indicated by an arrowhead marker with an ID code next to it. The vessel's course for the session is plotted as a continuous trace behind the arrowhead.

All plotting and text display is done on non-destructive bit-plane overlays, and is independent of the color map background.

### 3.2.2.3 Image Display

The task VIDMAP reads the required image files from disk, expands the compressed raster lines, assigns red, blue and green intensity to each pixel, then sends the resulting color TV image to the display terminal. VIDMAP is activated at start-up by the driver program (SSDRVL) to display an initial background map. Thereafter VIDMAP is activated to display new map views as selected by the operator. The sequence of operations involved in changing map view is as follows:

1. Operator specifies zoom level desired for new map.
2. Operator positions the cursor, on the existing map, to the desired center of the new map. (Cursor is joystick controlled.)
3. Operator requests new image to be displayed.
4. Driver program SSDRVL activates the task VIDMAP, which reads the necessary map file and displays the indicated map view.

The map files contain compressed images in the form of ID codes, as described in 3.2.1. The ID codes serve to identify map features but do



not provide any color information. Color assignments are contained in a separate table on disk, in which each ID code is listed along with its associated color. Color is specified by three gray scale levels, one each for the red component, blue component, and green component. These values may range from 1 to 255.

VIDMAP looks up the color assignments for each pixel using the ID code of the pixel as an index into the color assignment table. It then generates three output gray levels for each image pixel, corresponding to red, blue, and green. The resulting red, blue, and green images are loaded into the respective red, blue, and green image refresh memories in the display hardware, where they are automatically superimposed into a full color image on the screen.

#### 3.2.2.4 Driver

The driver task SSRVL provides operator control of the system. It initializes the system, displays an initial chart view, then activates the communications task. It then prompts the operator with a brief menu of functions:

1. REMAP - allows chart view to be changed (see 3.2.2.3).
2. TRANSMIT MESSAGE - allows entry of a message for transmission to the vessel.
3. POSITION BIAS - allows the operator to enter two correction values, one for latitude and one for longitude, to be added to or subtracted from every position before display.
4. CHANGE TRANSMISSION LAG TIMES - allows varying of the time lag between polls to Miami. (Value depends on Miami computer's loading.)

#### 4.0 COMMUNICATIONS AND MESSAGE HANDLING OF RSMAS

This section describes the communications and data management software developed by RSMAS, as part of the experimental coastal zone monitoring and offshore vessel tracking system.

##### 4.1 COMPUTER FACILITIES

This software was developed and run on the RSMAS satellite image processing system. The computer facility consisted of a Digital Equipment Corporation (DEC) PDP-11/55 computer and RSX-11M multi-user operating system. Nominally 4 to 6 users engage in software development, data processing, and image processing; the vessel tracking system software runs concurrently with other users.

##### 4.2 SOFTWARE SYSTEM

The software system consists of three major subsystems. (See Figure A-5) The polling subsystem (LORANBSDT) requests periodic positions from all active ships, sends text messages to ships, and receives text messages from ships.

The data logging subsystem (LORLOG) maintains a permanent archive of transactions with the polled ships.

The remote communication subsystem (LORGODSDT) relays text messages and position records from the ships to GSFC in Greenbelt, Maryland, and relays text messages from GSFC to the ships.

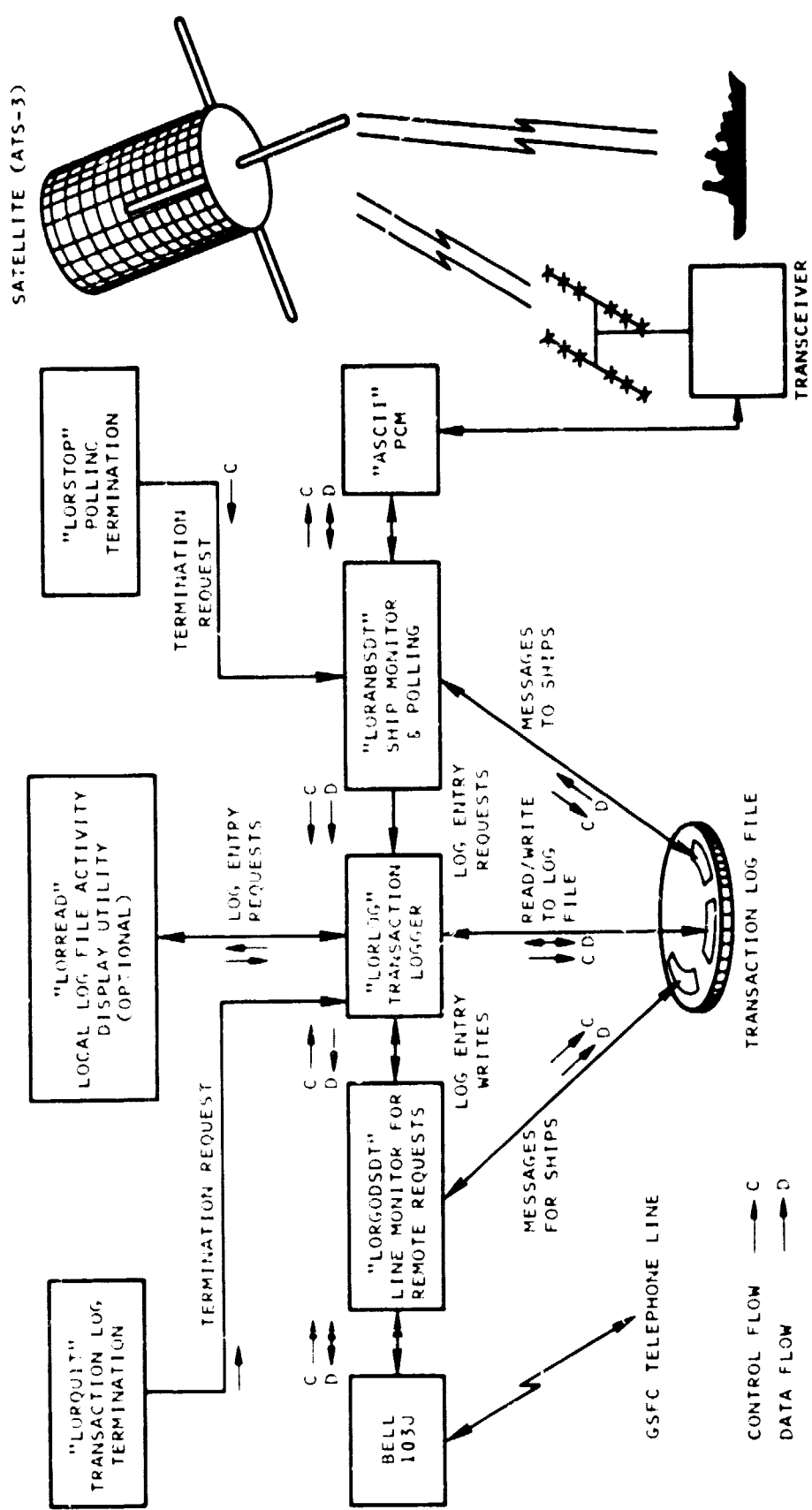

FIGURE A-5: Software System

#### 4.2.1 Ship Polling Subsystem

The subsystem LORANBSDT periodically polls all active ships for their current position or text messages. LORANBSDT also transmits text messages to the ships. A separate polling interval is available for each of these activities so that operation of the system can be configured to the expected demand.

Communications between MIAMI and the ships is via an addressable ASCII PCM driven by an asynchronous terminal interface on the computer. The ASCII PCM connects to a transmitter/receiver running on split frequencies to allow bi-directional (full duplex) communication with the ships. On-board the ship a similar installation is used to reconstruct the data sent by Miami in a format the shipboard BSR-43 teletype unit can interpret. Table A-4 contains the formats for Miami-to-ship communications.

#### 4.2.2 Data Logging

The data logging subsystem, LORLOG, maintains a permanent log file of ship transactions on disk. All incoming messages and position records from the ships are passed from LORANBSDT to LORLOG, which then adds them to the log file. (Internal communication between subsystems is accomplished by means of send and receive directives which are part of the computer operating system.)

The LORLOG subsystem allows up to four readers and many writers to the log file. Thus several independent programs may simultaneously access the log file under the computer's multi-user operating system. Since

the log file is in standard system text record format, it may be accessed by system text editing and printing utilities as well as by the LORLOG subsystem. Each logical record in the log file consists of one or more physical records. A logical record contains a record type (column 1) data source (column 2), date and time of transaction, and a data field for position/text. (See Figure A-6.)

#### 4.2.3 Goddard Space Flight Center Communications

The subsystem LORGODSDT is started by the Miami computer operator when communications with GSFC is desired, and it remains active throughout the ship tracking session. LORGODSDT continuously monitors the communications link to GSFC, waiting for a message. When it receives a "06" which is a request for data (See Table A-4), it requests a data record from LORLOG, which reads one from disk and passes it to LORGODSDT for transmission to GSFC. LORGODSDT sends one record in response to each "06" request, until all current text messages and position records on the log file have been sent to GSFC. At this point, LORGODSDT will respond to further GSFC requests with a null response of "#00", meaning no additional data is available, until such time as new ship data is received and added to the log file.

Text messages sent from GSFC to a ship are received by the subsystem LORGODSDT, which stores them on disk to be transmitted to the ship by LORANBSDT during the next available text polling interval. (See Tables A-3 and A-4).

Communications between Miami and GSFC are via Bell 103J (300 baud) modems on a dial-up telephone line. The modem connects to the computer through

```

A 09OCT79173606EAK 30HELLO, THIS IS ASCII TO THE COMPUTER
A+11OCT790032076KK 50^ DESTINATION: BALTIMOREKH#9HT91H6>1ZR,L.5P42-2
A 8)E/.HKZS
A 11OCT790047066KK 17SWEET HOME ALAAMA
A 11OCT790052066KK 23GO NAVY, BEAT ARMY!!!!
A 11OCT790137076KK 17SHINE ON SUNSHINE
A+11OCT790202066KK 50^ DESTINATION: BALTIMORE^ CHANNEL #
A+70A3^ BERTH/DOCK: NORTH 5^ ESTIMATED TIME OF ARRIVAL AT C
A+70HANNEL MARKER:^ 12 NOON^ 11 OCT 1979^ CARGO:
A+70YES^ " OFFLOAD: YES^ REFUEL: YES, DIESEL #1^ 4000
A+70 GALLONS^ ESTIMATED TIME OF DEPARTURE:^ 12 NOON^
A 1
L 11OCT790242256KK 22+ 36 54.60 + 76 6.95
A+11OCT790462066KK 50GETTING TIRED. LONG DAY TODAY, BUT^ DORGER IN
A+70E TOMORROW. TURN IN TIME IS 12:44.....TURN IN TIME IS 12:46 AM 11
A 59 OCT 1979^ BYE!.....BYE!!!!!!!!!!!!
A 11OCT790737066KK 17GOOD MORNING PAUL
A 11OCT790752066KK 30DID NOT GET TTY BUFFER TRIGGER
A+11OCT790842076KK 50^ DESTINATION: BALTIMORE^ CHANNEL#
A+70A3^ BERTH/DOCK:"NORTH 5^ ESTIMATED TIME OF ARRIVAL AT C
A+70HANNEL MARKER:^ 12 NOON^ OCT 11, 1979^ CARGO:
A+70 YES^ OFFLOAD: YES^ REFUEL: YES, DIESEL #1^ 40
A+7000 GALLONS^ ESTIMATED TIME OF DEPARTURE:^ 12 NOON^
A 3
A 11OCT790847076KK 42^ SEEMS OK. BOY WILL KEEP AN EYE ON IT
A+11OCT790857076KK 50^ DESTINATION: NORFOLK^ CHANNEL# 30
A+70^ BERTH/DOCK: SOUTH 32^ ESTIMATED TIME OF ARRIVAL AT CH
A+70HANNEL MARKER:^ 12 NOON^ OCT 11, 1979^ CARGO:
A+70GENERAL^ OFFLOAD: YES^ REFUEL: YES, DIESEL #1^
A 664000 GALLONS^ ESTIMATED TIME OF DEPARTURE:^ 12 NOON^
TL11OCT791048526KK
TL11OCT791049376KK
TL11OCT791050226KK
TA11OCT791050586KK
TL11OCT791051176KK
TL11OCT791051526KK
TL11OCT791052376KK
TL11OCT791053076KK
L 11OCT791053526KK 22- 36 24.53 + 76 0.89
BL11OCT791054376KK 22+ 27265.06 + 41232.09
TA11OCT791055156KK
BL11OCT791055286KK 22+000837.3.;+000=979.1
FL11OCT791056076KK
L 11OCT791056526KK 22+ 36 54.64 + 76 9.98
A 11OCT791057256KK 37^ HAKER TEST STATION 'SUNSHINE'
BL11OCT791057386KK 22+<50R;7.=.4-1>=>;2<4
L 11OCT791058226KK 22+ 36 54.64 + 76 10.00
A 11OCT791059176KK 33^ DAT/LONG AT 11:00 AM LOCAL
FL11OCT791059376KK
L 11OCT791059576KK 22+ 36 53.85 + 76 10.40
L 11OCT791100376KK 22+ 36 54.64 + 76 10.01
A 11OCT791101176KK 33^ DAT/LONG AS OF 11:01 AM LG
TL11OCT791118556KK
TL11OCT791119566KK
TL11OCT791120566KK
TA11OCT791121496KK
TL11OCT791122096KK
TL11OCT791122566KK
TA11OCT791124196KK
TL11OCT791124396KK
TL11OCT791127036KK
TL11OCT791127476KK
TL11OCT791128336KK
TL11OCT791129186KK
TL11OCT791209156KK
A 11OCT791210256KK 20CHARACTERS ANYTHING^
TL11OCT791211066KK
TL11OCT791211506KK
TL11OCT791212366KK

```

FIGURE A-6: Typical Logical Record

an asynchronous terminal interface (one of eight terminals on a multiplexer). I/O is done through the standard terminal driver for the RSX-11M operating system using Q10 (Queue I/O) requests. All data is in the form of ASCII character strings. (See Table A-3.)

TABLE A-4

1. Request for position record to be transmitted from ship:

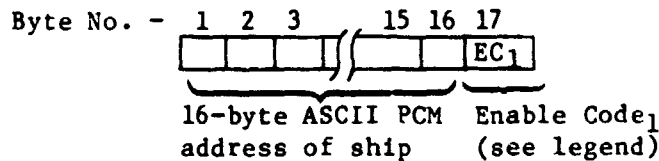

2. Position record from ship:

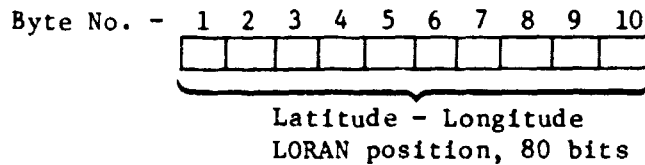

3. Request for text message to be transmitted from ship, and optional text message transmission to ship:

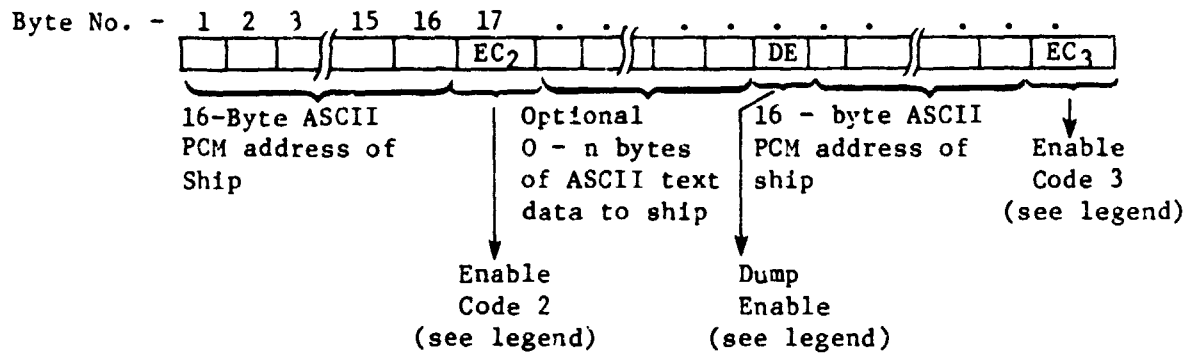

4. Text Message from ship:

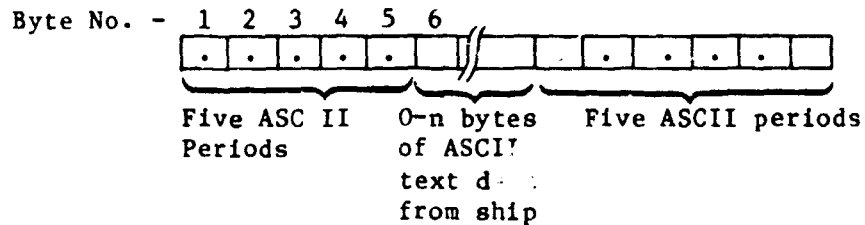

LEGEND:

Enable Code <sub>1</sub>	20g - Transmit 4 frames containing reply
	40g - Transmit 8 frames containing reply
	60g - Transmit 16 frames containing reply
Enable Code <sub>2</sub>	01g - ASCII PCM text receive enable
Enable Code <sub>3</sub>	04g - ASCII PCM text transmit enable
Dump Enable	21g - Dump BSR43 text buffer



**APPENDIX B**

**DETAILED EXPERIMENT DATA**

**1.0 EXPERIMENTS OF JUNE 9-16, 1979**

**2.0 EXPERIMENTS OF JULY 25-AUG. 3, 1979**

## APPENDIX B

### DETAILED EXPERIMENT DATA

#### 1.0 EXPERIMENTS OF JUNE 9-16, 1979

Figure B-1 shows a portion of the total data obtained during the first series of experiments in the lower section of the Chesapeake Bay. These data were obtained from RSMAS, Miami, computer interrogations of the shipboard LORAN-C via ATS-3 satellite and stored on disk at the computer facility. The actual printouts were generated by playback to the vessel from RSMAS, Miami via satellite after the vessel had returned to its home port.

The test area is that section of the lower Bay for which charts have been digitized and put in the computer for display on the TV monitor. The northern boundary of the test area is approximately 37°20.' North latitude. Following the completion of tests the vessel proceeded on north heading toward home port near Annapolis. The vessel's position was interrogated approximately once every minute and tracked nearly continuously during the return trip and positions recorded as indicated. North of 37°20.' N Latitude the data is useful for determination of position and accuracy of the LORAN-C; however, it was not displayed on the TV monitor.

#### 2.0 EXPERIMENTS OF JULY 25 THROUGH AUGUST 3, 1979

Figure B-2 shows a portion of the total data obtained during the second series of experiments in the lower section of the Chesapeake Bay.

These data were obtained from RSMAS, Miami, computer interrogations of the shipboard LORAN-C via ATS-3 satellite and stored on disk at the computer facility. The actual printouts were generated by the playback to the vessel from RSMAS, Miami via satellite after the vessel had returned to its home port.

L 12JUN7920484BKKR	22+	37	31.13	+	76	9.58
L 12JUN79205036BKKR	22+	37	31.36	+	76	9.19
L 12JUN79205136BKKR	22+	37	31.43	+	76	9.28
L 12JUN79205347BKKR	22+	37	31.77	+	76	9.70
L 12JUN79205407BKKR	22+	37	31.78	+	76	9.57
L 12JUN79205436BKKR	22+	37	31.84	+	76	9.56
L 12JUN79205536BKKR	22+	37	31.96	+	76	9.61
L 12JUN79205636BKKR	22+	37	32.09	+	76	9.57
L 12JUN79205848BKKR	22+	37	32.35	+	76	9.52
L 12JUN79205936BKKR	22+	37	32.46	+	76	9.52
L 12JUN79210036BKKR	22+	37	32.53	+	76	9.49
L 12JUN79210136BKKR	22+	37	32.67	+	76	9.43
L 12JUN79210347BKKR	22+	37	32.91	+	76	9.41
L 12JUN79210407BKKR	22+	37	32.95	+	76	9.43
L 12JUN79210436BKKR	22+	37	33.00	+	76	9.41
L 12JUN79210536BKKR	22+	37	33.14	+	76	9.35
A+12JUN79210802BKKR 500N MY RDF. ON THE RADIO BEACON FREQ.. THERE IS A BA						
A+70D GENERATOR INTERFERENCE AT A MOTOR BOATING RATE WHICH IS QUITE LOU						
A+70. SO THERE IS SOMETHING ESCAPEING FROM THE GENERATOR. IT WAS THERE						
A 36WD DAYS AGO .YESTERDAY AND TODAY,BUT						
L 12JUN79210822BKKR	22+	37	33.46	+	76	9.32
L 12JUN79210936BKKR	22+	37	33.62	+	76	9.35
L 12JUN79211036BKKR	22+	37	33.70	+	76	9.31
L 12JUN79211136BKKR	22+	37	33.86	+	76	9.31
L 12JUN79211348BKKR	22+	37	34.10	+	76	9.41
L 12JUN79211408BKKR	22+	37	34.17	+	76	9.38
L 12JUN79211436BKKR	22+	37	34.19	+	76	9.32
L 12JUN79211844BKKR	22+	37	34.73	+	76	9.21
L 12JUN79211936BKKR	22+	37	34.86	+	76	9.25
L 12JUN79212036BKKR	22+	37	34.93	+	76	9.19
L 12JUN79212136BKKR	22+	37	35.08	+	76	9.17
L 12JUN79212347BKKR	22+	37	35.35	+	76	9.13
L 12JUN79212636BKKR	22+	37	35.68	+	76	9.03
L 12JUN79212908BKKR	22+	37	36.06	+	76	9.01
L 12JUN79212936BKKR	22+	37	36.12	+	76	9.02
L 12JUN79213344BKKR	22+	37	36.47	+	76	8.95
L 12JUN79213436BKKR	22+	37	36.74	+	76	9.03
L 12JUN79213636BKKR	22+	37	36.99	+	76	8.93
L 12JUN79213848BKKR	22+	37	37.31	+	76	8.89
L 12JUN79213908BKKR	22+	37	37.36	+	76	8.89
L 12JUN79213936BKKR	22+	37	37.40	+	76	8.89

U.S. GOVERNMENT PRINTING OFFICE: 1979

FIGURE B-1: Typical Data Obtained During Experiments of June 9-16, 1979

L 01AUG79183058BKR 22+ 37 15.63 + 76 7.08  
 L 01AUG79183231BKR 22+ 37 15.68 + 76 7.08  
 L 01AUG79183331BKR 22+ 37 15.43 + 76 7.15  
 A 01AUG79183518BKR 32ENTER YORK SPLIT CHANNEL 6:30 PM  
 L 01AUG79183538BKR 22+ 37 15.23 + 76 7.21  
 L 01AUG79183631BKR 22+ 37 15.17 + 76 7.28  
 L 01AUG79185231BKR 22+ 37 14.49 + 76 7.56  
 L 01AUG79185331BKR 22+ 37 14.44 + 76 7.58  
 L 01AUG79185538BKR 22+ 37 14.23 + 76 7.67  
 L 01AUG79185558BKR 22+ 37 14.19 + 76 7.69  
 L 01AUG79185631BKR 22+ 37 14.15 + 76 7.71  
 L 01AUG79185831BKR 22+ 37 13.94 + 76 7.80  
 A+01AUG79190018BKR 50ENTERED YORK SPIT CHANNEL AT 6:30 P.M.--- LOST GENL  
 A 46RATOR POWER AT 6:45 P.M AND WENT TO IDLE AHEAD  
 L 01AUG79190058BKR 22+ 37 13.65 + 76 7.92  
 L 01AUG79190131BKR 22+ 37 13.61 + 76 7.95  
 L 01AUG79190231BKR 22+ 37 13.52 + 76 7.97  
 L 01AUG79190534BKR 22+ 37 13.17 + 76 8.06  
 L 01AUG79190831BKR 22+ 37 12.88 + 76 8.19  
 A+01AUG79191018BKR 50 GENERATOR STOPPED OVERHEATED OR GOT AN AIR LOCK I  
 L 01AUG79191038BKR 22+ 37 12.63 + 76 8.29  
 L 01AUG79191058BKR 22+ 37 12.57 + 76 8.30  
 L 01AUG79191131BKR 22+ 37 12.53 + 76 8.31  
 L 01AUG79191331BKR 22+ 37 12.33 + 76 8.41  
 L 01AUG79191558BKR 22+ 37 12.09 + 76 8.51  
 L 01AUG79191631BKR 22+ 37 11.98 + 76 8.53  
 L 01AUG79191731BKR 22+ 37 11.89 + 76 8.51  
 L 01AUG79191831BKR 22+ 37 11.78 + 76 8.64  
 A 54 SPLIT CHANNEL- FOLLOWING CHANNEL TOWARD BRIDGE-TUNNEL  
 L 01AUG79192037BKR 22+ 37 11.55 + 76 8.65  
 L 01AUG79192057BKR 22+ 37 11.52 + 76 8.70  
 L 01AUG79192131BKR 22+ 37 11.46 + 76 8.72  
 L 01AUG79192231BKR 22+ 37 11.34 + 76 8.77  
 L 01AUG79192331BKR 22+ 37 11.27 + 76 8.83  
 L 01AUG79192538BKR 22+ 37 11.04 + 76 8.86  
 L 01AUG79192631BKR 22+ 37 10.93 + 76 8.91  
 L 01AUG79192731BKR 22+ 37 10.83 + 76 8.88  
 L 01AUG79193034BKR 22+ 37 10.49 + 76 8.83  
 L 01AUG79193054BKR 22+ 37 10.43 + 76 8.78  
 L 01AUG79193131BKR 22+ 37 10.39 + 76 8.78  
 L 01AUG79193231BKR 22+ 37 10.26 + 76 8.77  
 L 01AUG79193331BKR 22+ 37 10.17 + 76 8.76

FIGURE B-2: Typical Data Obtained During Experiments of July 25-August 3, 1979