

N O T I C E

THIS DOCUMENT HAS BEEN REPRODUCED FROM
MICROFICHE. ALTHOUGH IT IS RECOGNIZED THAT
CERTAIN PORTIONS ARE ILLEGIBLE, IT IS BEING RELEASED
IN THE INTEREST OF MAKING AVAILABLE AS MUCH
INFORMATION AS POSSIBLE

PT

NASA Technical Memorandum 82654

(NASA-TM-82654) FIBER OPTICS FOR AIRCRAFT
ENGINE/INLET CONTROL (NASA) 13 p
HC A02/MF A01

N81-31190

CSCL 01D

Unclass

G3/06 27422

Fiber Optics for Aircraft Engine/Inlet Control

Robert J. Baumbick
Lewis Research Center
Cleveland, Ohio



Prepared for the
International Symposium and Instrument Display
sponsored by the Society of Photo-optical
Instrumentation Engineers
San Diego, California, August 24-28, 1981

NASA

FIBER OPTICS FOR AIRCRAFT ENGINE/INLET CONTROL

Robert J. Baumbick

National Aeronautics and Space Administration
Lewis Research Center
Cleveland, Ohio 44135

SUMMARY

A review of NASA programs that focus on the use of fiber optics for aircraft engine/inlet control is presented. Fiber optics for aircraft control is attractive because of its inherent immunity to EMI and RFI noise. Optical signals can be safely transmitted through areas that contain flammable or explosive materials. The use of optics also makes remote sensing feasible by eliminating the need for electrical wires to be connected between sensors and computers. Using low-level optical signals to control actuators is also feasible when power is generated at the actuator.

For engine/inlet control applications, fiber optic cables and connectors will be subjected to nacelle air temperatures. These temperatures range from -55° to 260° C. Each application of fiber optics for aircraft control has different requirements for both the optical cables and the optical connectors. Sensors that measure position and speed by using slotted plates can use lossy cables and bundle connectors if data transfer is in the parallel mode. If position and speed signals are multiplexed, cable and connector requirements change. Other sensors that depend on changes in transmission through materials require dependable characteristics of both the optical cables and the optical connectors.

A variety of sensor types are reviewed, including rotary position encoders, tachometers, temperature sensors, and blade tip clearance sensors for compressors and turbines. Research on a gallium arsenide photoswitch for optically switched actuators that operate at 250° C is also described.

INTRODUCTION

Fiber optics is being seriously considered for control and monitoring functions in future aircraft because it offers a number of advantages over electrical wire systems. Optical systems are attractive for use in aeronautics because of their inherent immunity to electromagnetic interference (EMI). Optical signal transmission is safe to use in areas that contain flammable or explosive materials because of the absence of electrical energy in the fiber. The use of optics results in remote passive sensors. No electrical energy is supplied to the sensor. A potential weight saving is offered because optical fibers do not require EMI shielding. However, rugged, lightweight optical cables must be developed that do not require metal conduit for protection if the weight saving is to be realized.

This paper discusses NASA Lewis Research Center programs to develop optical sensors and optically controlled actuators for airbreathing engine control. These sensors and actuators will need reliable fiber optic transmission paths and connectors for fiber bundles and single fibers. The requirements for fiber optic cables and optical connectors differ. For digital sensors with binary outputs, such as position sensors, the absence or presence of light at levels sufficient to excite the detector has to be transmitted. Other sensors whose output is optical intensity variations

require low-loss cables and connectors. Optically driven actuators require specific minimum optical power levels delivered to the photoswitches.

The optical cables, connectors, and sensors must function in severe temperature and vibration environments. The actual ambient temperature and vibration levels will depend on the aircraft mission. Supersonic aircraft flying at high Mach numbers will have nacelle air temperatures as high as 260° C. The full range of temperature to which these components will be subjected is from -55° to 260° C. The vibration environment to which these optical components will be subjected will generally be more severe than the widely used MIL-STD-810B specification. Vibration levels in the 500- to 20 000-hertz range could be above this military specification with respect to both amplitude and maximum frequency (ref. 1). The most severe vibrations occur on the fan case.

Figure 1 illustrates the measurements required for engine/inlet control. These include sensors to measure speed, position, pressure, and temperature. Flight Mach number, computed from free-stream total and static pressures, is used for scheduling inlet geometry. Pressure measurements, in mixed-compression inlets, are used for snock position control. Inlet ramps, spikes, and bypass door positions are required as well as engine stator vane position for the fan and compressor. This engine geometry scheduling is a function of gas temperature and engine speed. Turbine temperatures and engine speed must be monitored to prevent either excess speed or excess temperature. Pressure measurements are required for engine fuel flow control.

On most current aircraft the digital computer is mounted on the engine and is usually fuel cooled to protect the electronics. The electrical pressure sensors are usually included in the fuel-cooled environment to minimize the temperature effect. Passive, optical pressure sensors that are insensitive to temperature can be mounted at the point of measurement. Signals to and from the sensor will be via fiber optic cable. Thermocouple temperature measurements are relatively low-level signals, susceptible to noise contamination. Optical temperature sensors will eliminate the noise problem. Actuator position measurements that are now electrical can be replaced with optical position sensors whose outputs are digital compatible.

SENSORS

For remote optical sensors no electrical energy is supplied to the sensor. The light source and detector are in a controlled environment (computer box). Optical cables conduct optical power to the sensor and return the modulated optical signal to the computer for processing.

Figure 2 shows two remote optical sensors. One is a nine-bit 360° rotary encoder. The other is a nine-pulse-per-revolution optical tachometer. Both these sensors were built for operation with the light source and detector located remotely from the sensors. The source/detector was coupled to the sensors with 3.65 meters of a bundle type of fiber optic cables. The cables were enclosed in a Teflon sheath. Limited environmental testing was done on these sensors. Temperatures did not exceed 149° C. The sensors were installed on an F-100 engine for testing in an altitude chamber. The rotary encoder measured compressor stator vane position. The tachometer measured engine core speed. Figure 3 shows the encoder and tachometer installed on the F-100 engine. The optical cables were enclosed in conduits to protect them. These engine-mounted sensors worked well for over 100 hours of engine testing. More information on these sensors is presented in reference 2.

Because of potential performance gains and fuel savings, compressor and turbine tip clearance measurement and control are being considered for future aircraft. The amount of clearance that exists between the rotor and case of the fan, compressor, and turbine is the parameter to be measured and controlled.

Optical methods for measuring these clearances have been proposed. One concept, developed by General Electric under contract to NASA Lewis, is shown in figure 4. A model of this sensor was built and tested in the laboratory by using a compressor rotor driven by an electric motor. A light beam is directed tangent to the engine case. The rotor blade intercepts part of the beam. Clearance is determined by the number of detectors receiving light from the source. The receiver consists of a coherent bundle arranged in a vertical array and terminated in a series of light detectors. Further development of this sensor is necessary before using this concept to measure actual clearances on an operating engine, especially in the turbine region, where the most significant contribution to improved engine efficiency is expected. A detailed report on the work done on this sensor concept is presented in reference 3.

An optical temperature sensor, developed under contract by United Technologies Research Center (UTRC), is shown in figure 5. Operation of this sensor is based on the temperature-dependent absorptive characteristics of a rare-earth (europium)-doped optical fiber. Rare earth materials like europium have energy states close to the ground state. These states are optically connected to higher excited states with energy differences that correspond to wavelengths in the visible region. The strength of absorption is a function of the number of electrons in the state from which the transition originates. The number of electrons in each state is a unique function of temperature. Figure 6 shows the transmission as a function of temperature for europium-doped fiber. Well-defined absorption peaks can be identified at approximately 550 nanometers and at 610 nanometers. A sensitivity curve of transmission through the fiber versus the sensor temperature is shown in figure 7. The optical fiber used for this sensor had a 204-micrometer core diameter. This sensor concept is discussed in more detail in reference 4.

Under a current contract with NASA Lewis, UTRC is building a sensor capable of measuring temperatures to 1700° C. A prototype will be built for measuring interturbine temperatures in a turboshaft engine. Although the engine interturbine temperatures are not expected to exceed 800° C, the 1700° C goal will accommodate future engines for which turbine inlet temperatures are expected to approach this temperature. Yttrium aluminum garnet (YAG) is being considered as the host material for this sensor, with neodymium as the dopant. The exact materials and construction of this probe have not been fully defined. Figure 8 shows one configuration for this probe. Light enters the cold end of the probe and is directed to the sensing element in the hot end by means of sapphire optics. The light passes through the specimen and is reflected and returned to the detector through a fiber optic cable. The change in transmission through the specimen correlates to the specimen temperature.

A second temperature sensor concept developed by Rockwell (NASA CR-165362, to be published) under contract to NASA Lewis is based on the Fabry-Perot interferometer. Two highly reflective surfaces with a metallic space make up the Fabry-Perot cavity (fig. 9). Broadband light input to this cavity is modulated as the spacing between reflective faces changes. The metallic spacer, sensitive to temperature, varies the gap thickness.

The actual sensor is shown in figure 10. Two (300- μm core) optical fibers conduct broadband light to the sensor and return the modulated signal to the dispersing system. The modulated spectrum is dispersed by a prism and focused on an array (128 element) of charge-coupled devices (CCD). The CCD output is processed by a microprocessor to compute temperature from the spectral information. An example illustrating how the transmitted spectrum changes as the gap is varied is shown in figure 11.

The sensor was successfully tested over the temperature range 70° to 575° C. Considerably more work is required before definitive figures for resolution are established. Estimates indicate that a resolution of 0.5 percent of full scale is possible. A very detailed account of sensor construction and the data analysis techniques used is presented in the contractor's final report (NASA CR-165362, to be published).

ACTUATORS

Actuators that are powered or controlled by light may be part of future aircraft systems. In these schemes the actuator is driven by a two-stage electrohydraulic servovalve. Hydraulic power is supplied to the servovalve. Figure 12 illustrates two schemes that use optical power to drive an actuator. In the first scheme (fig. 12(a)) optical energy is converted to electrical energy (solar cell). This electrical energy is used to drive the first-stage torque motor directly. In the second scheme (fig. 12(b)) optical power is used to control the flow of electrical energy to the torque motor. In this configuration electrical energy is generated at the point of use. The electrical energy for this scheme does not have to be well regulated. Optical control signals generated at the control computer are sent to a phototransistor. This phototransistor drives a power transistor that controls power to the actuator. UTRC, under contract to NASA Lewis, is developing high-temperature components for this type of application. These devices must operate at temperatures to 260° C. Gallium arsenide is being used for the devices because of the high temperatures. Figure 13 shows two configurations of optical switching: light on the phototransistor and the power switch off (fig. 13(a)), and light on the phototransistor and the power switch on (fig. 13(b)). The optical path for these configurations uses a 200-micrometer core fiber. The goal of this program is to switch 100 milliamperes of current with an off-state voltage of 20 volts at 260° C. The validity of design has been verified by operating a gallium arsenide - JFET switch with a gallium aluminum arsenide phototransistor. A current of 50 milliamperes was switched into a resistive load with 235 microwatts of optical power incident on the phototransistor.

CONCLUDING REMARKS

NASA programs dealing with optical sensors and optically controlled actuators have been discussed. The reliability of future systems that use optical components will depend in large part on the fiber optic cables and connectors. These components, along with the sensors, will have to operate over very wide temperature ranges. Currently the temperature specifications range from -55° to 260° C. Future higher speed aircraft will result in yet higher temperatures.

Optical cable and optical connector requirements for sensor operation, communications, and data transmission differ. The encoder, tachometer, and tip clearance sensors use fiber optic bundles; the temperature sensors and

the photoswitch use single fibers. These cables must be rugged yet light-weight without requiring heavy metal sheathing for protection. The connectors for these fibers must be low loss and reliable, especially the single-fiber connectors. The integrity of these optical systems must be maintained in spite of the severe temperature and vibration environment of an operating engine. The ability to operate in hostile environments will determine the future of optics in aircraft control systems.

REFERENCES

1. C. B. Kunkle and M. E. McGlone, AIAA Paper 79-0385 (Jan. 1979).
2. R. J. Baumbick, NASA TM-81454 (1980).
3. G. L. Poppel and D. T. F. Marple, NASA CR-165265 (General Electric), (1981).
4. W. W. Morey, W. H. Glenn, R. O. Decker, W. C. McClurg, NASA CR-165125 (R80-924624-11, United Technologies Research Center, East Hartford, CT.), (1980).

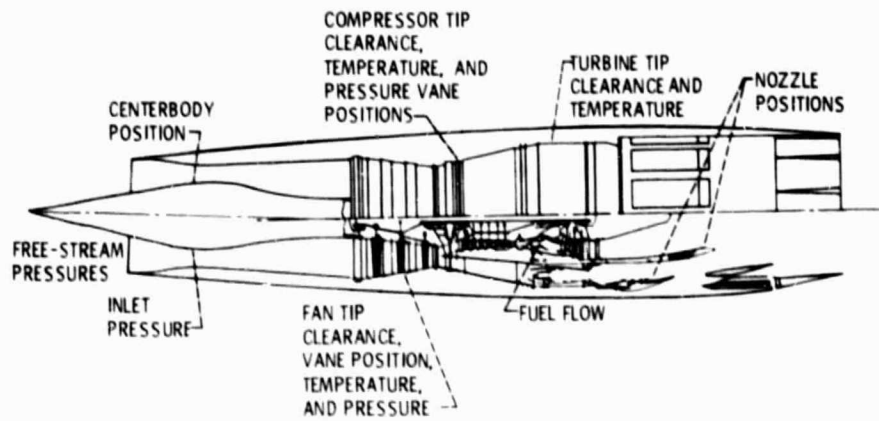
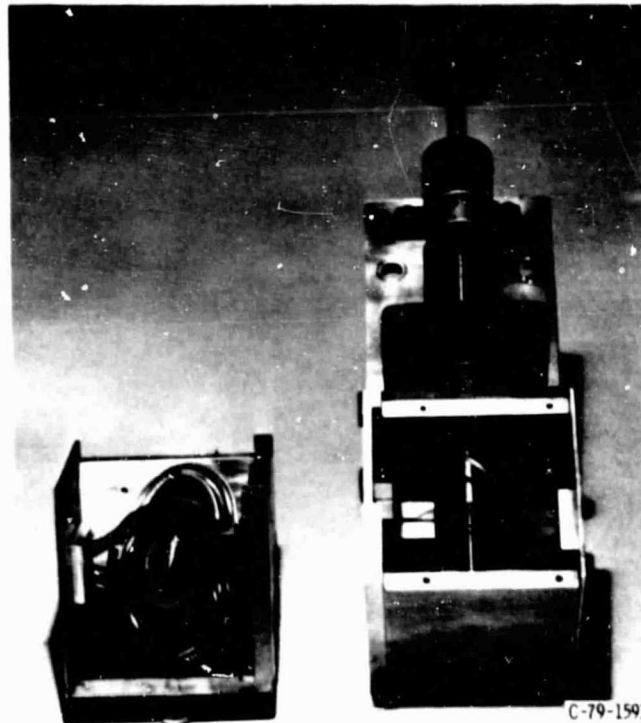

Figure 1. - Inlet/engine measurements for control and monitoring.



(a) Passive optical rotary encoder (9 bits).

(b) Passive optical tachometer (9 pulses per revolution).

Figure 2. - Optical rotary encoder and tachometer.

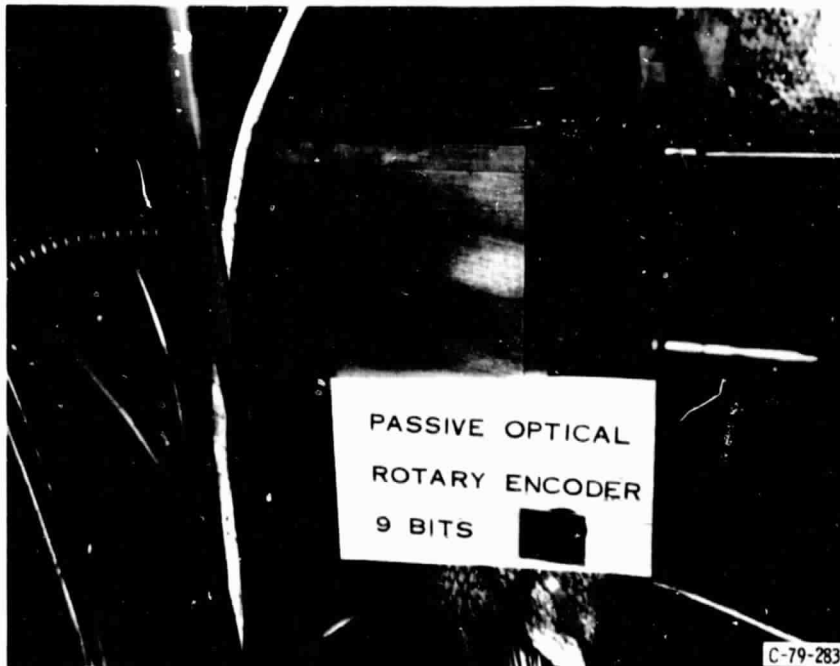

(a) Optical encoder mounted on engine.

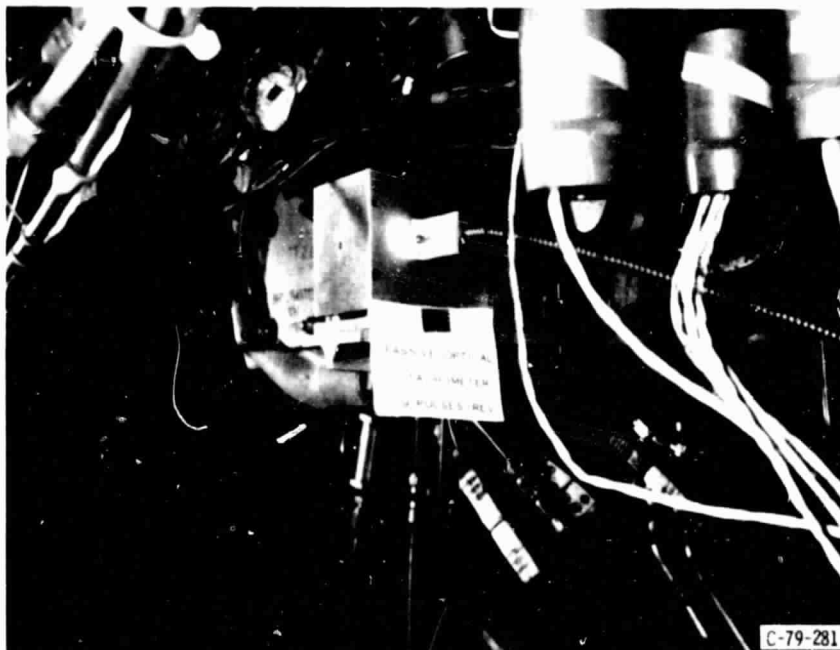

(b) Optical tachometer mounted on engine.
Figure 3. - Sensors mounted on test engine.

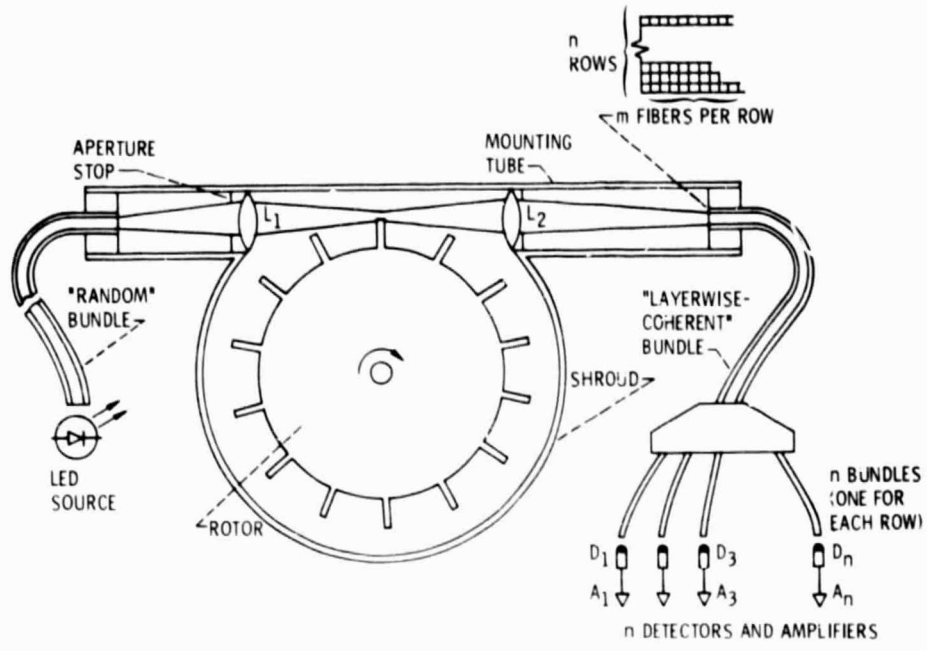
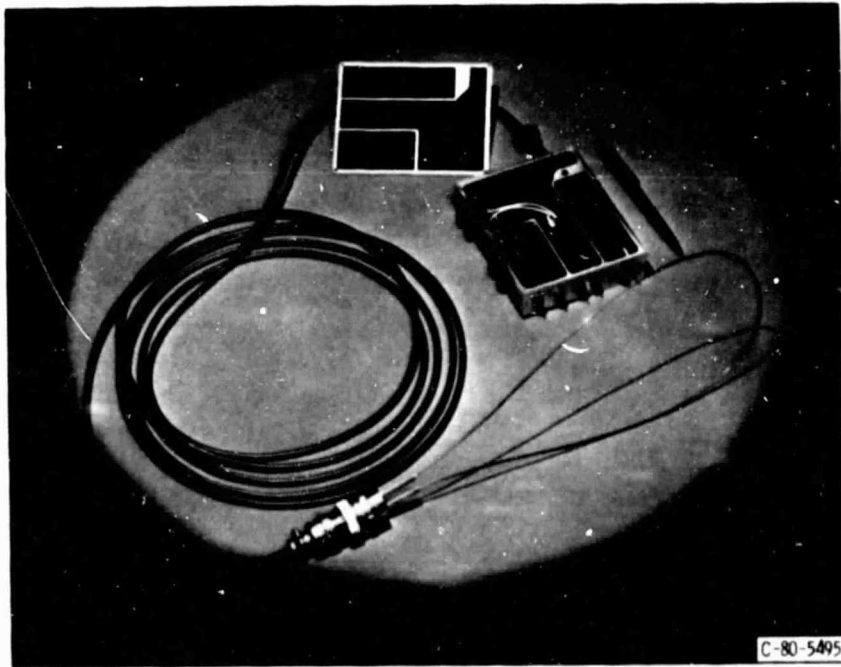

Figure 4. - Optical tip clearance sensor.

RECEIVED
 DEPT. OF DEFENSE



C-80-5495

Figure 5. - Optical temperature sensor using europium-doped fiber.

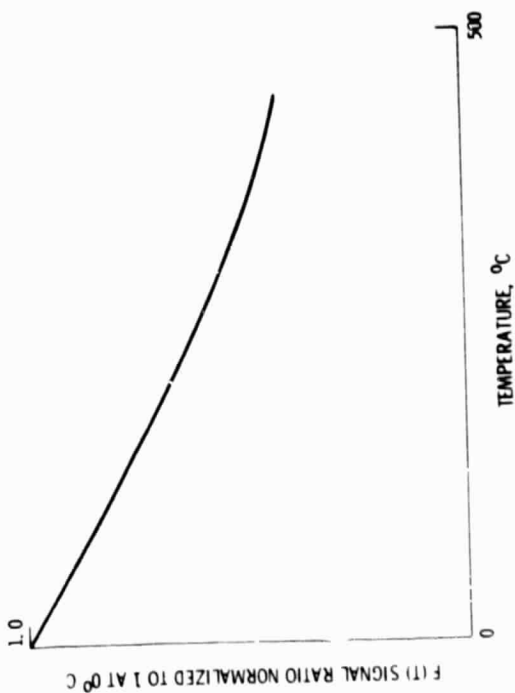

Figure 7. - Temperature dependence of europium fiber optic sensor.

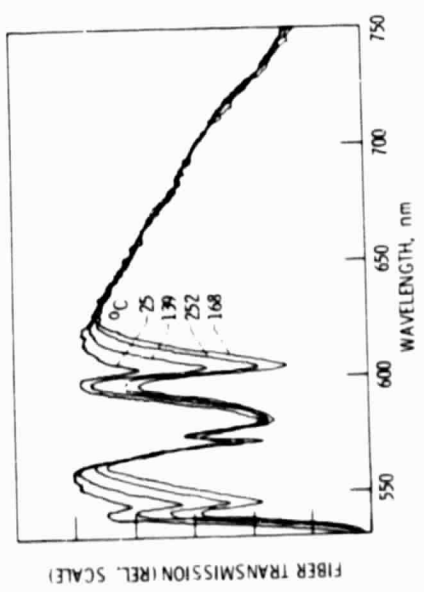

Figure 6. - Characteristics of europium-doped fiber as function of temperature.

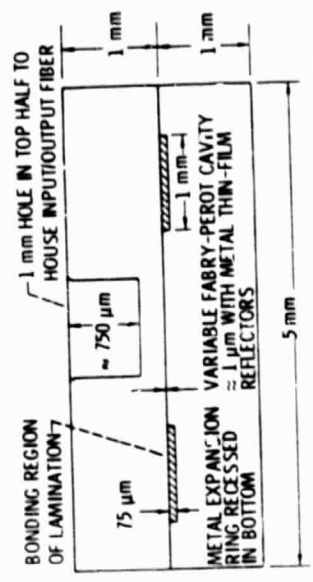

Figure 9. - Construction of the Fabry-Perot interferometer.

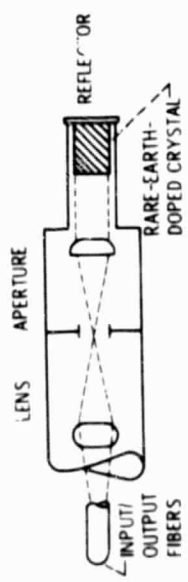

Figure 8. - Schematic of temperature-sensing probe for measuring temperatures to 1700°C.

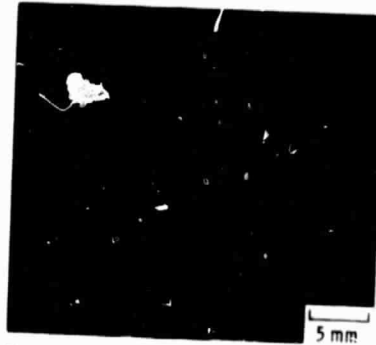

Figure 10. - Fabry-Perot temperature sensor.

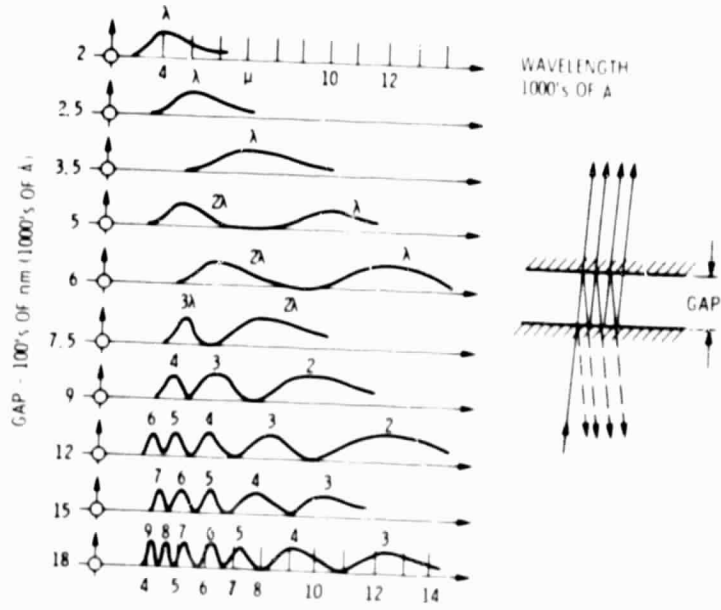
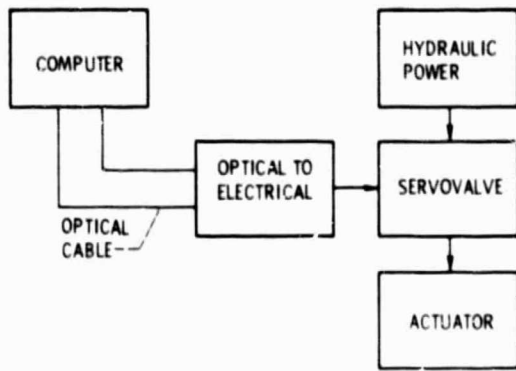
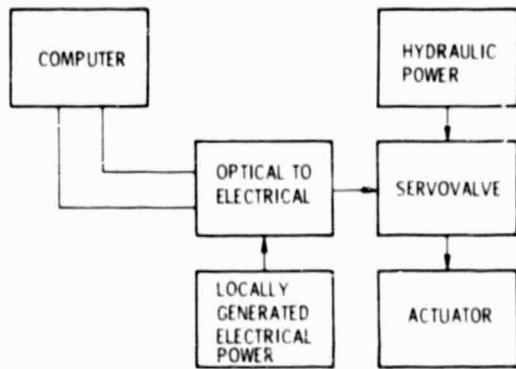

Figure 11. - Transmitted spectrum as function of gap width.

ORIGINAL PAGE IS
OF POOR QUALITY



(a) Optical power transmission and conversion at actuator.



(b) Optically controlled switch with locally generated power for driving actuator.

Figure 12. - Configurations for driving actuators with optical signals.

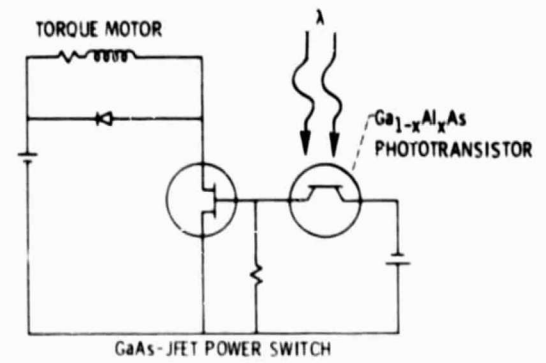

(a) Light on, power switch off.

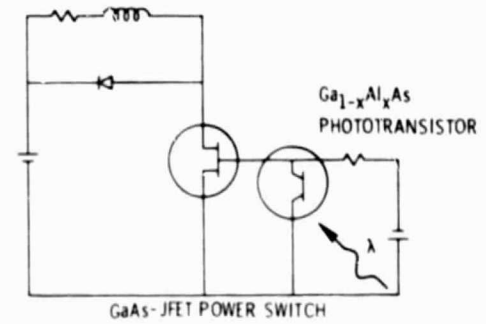

(b) Light on, power switch on.

Figure 13. - Configurations for optical switching of actuators.