

Space Shuttle News Reference

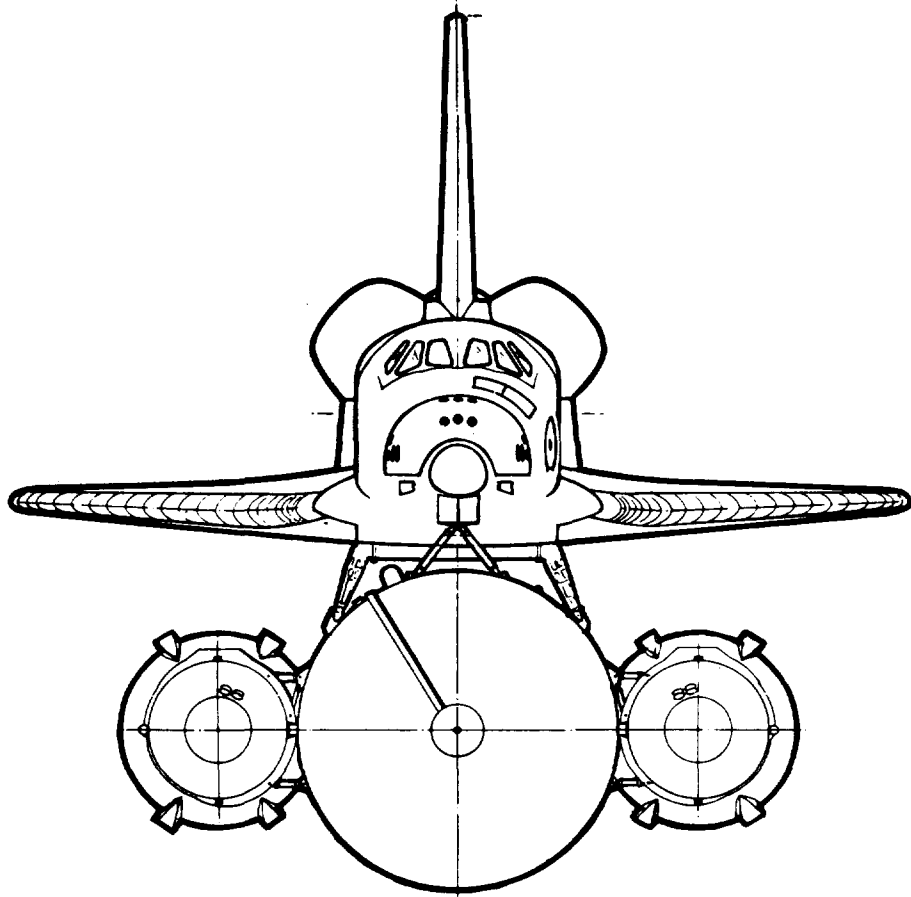

NASA
National Aeronautics and
Space Administration

Foreword

of the
the best
ation
the
gran
ion on sp
vlob

ORIGINAL PAGE
POOR



CONTENTS

1	INTRODUCTION	1-1
2	SPACE TRANSPORTATION SYSTEM	
	PROPULSION	2-1
	Space Shuttle Main Engines	2-3
	Solid Rocket Boosters	2-17
	External Tank	2-33
3	ORBITER STRUCTURE	3-1
4	ORBITER SYSTEMS	4-1
	Propulsion	4-3
	Power Generation	4-9
	Environmental Control and Life Support System	4-17
	Thermal Protection	4-25
	Purge, Vent, and Drain System	4-33
	Avionics	4-37
5	ORBITER CREW ACCOMMODATIONS AND EQUIPMENT	5-1
6	MISSION OPERATIONS AND SUPPORT	6-1
	Launch and Landing Facilities and Operations	6-3
	Tracking and Communications Network ..	6-43
	Flight Operations and Mission Control	6-49
7	FLIGHTCREW COMPLEMENT AND CREW TRAINING	7-1
8	TESTING	8-1
9	MANAGEMENT	9-1
10	CONTRACTORS	10-1
	APPENDIXES	
A	Acronyms and Abbreviations	A-1
B	Glossary	B-1
C	Unit Conversion Table	C-1

PRECEDING PAGE BLANK NOT FILMED

1. INTRODUCTION



1. INTRODUCTION

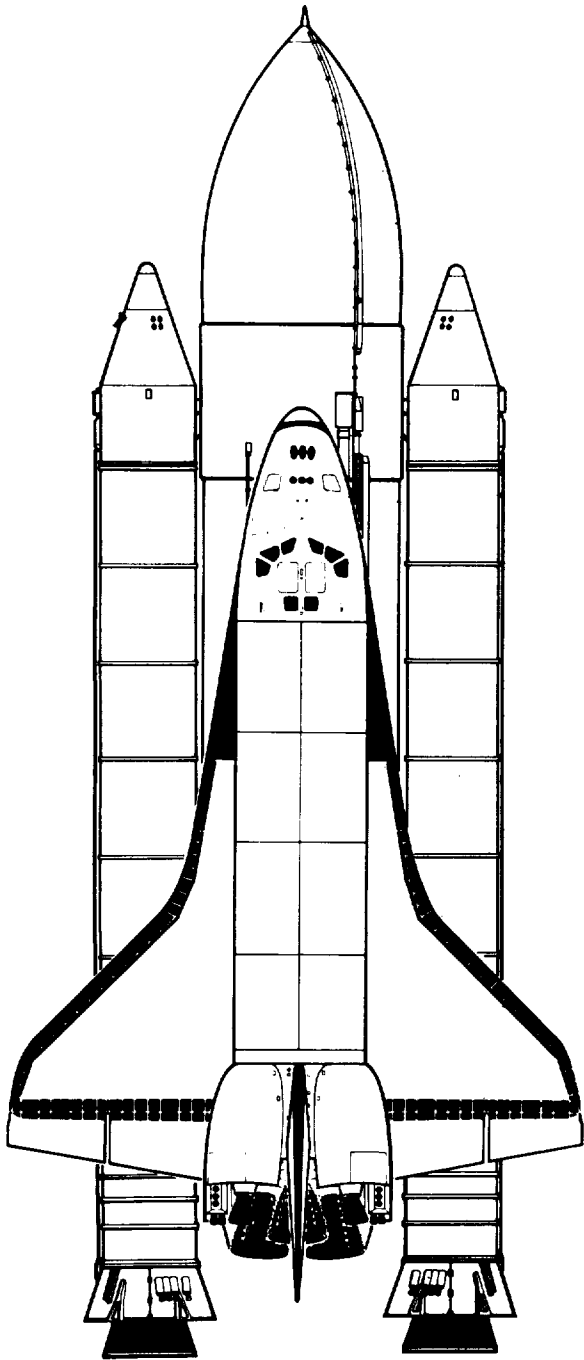

Development History	1-5
A Versatile Vehicle	1-6
Space Shuttle Components	1-7
Typical Shuttle Mission	1-9
Crew	1-10

Briefly . . .

The primary function of the Space Shuttle is to deliver payloads to Earth orbit. On a standard mission, the Orbiter will remain in orbit for 7 days, return to the Earth with the flightcrew and the payloads, land like an airplane, and be readied for another flight in 14 days.

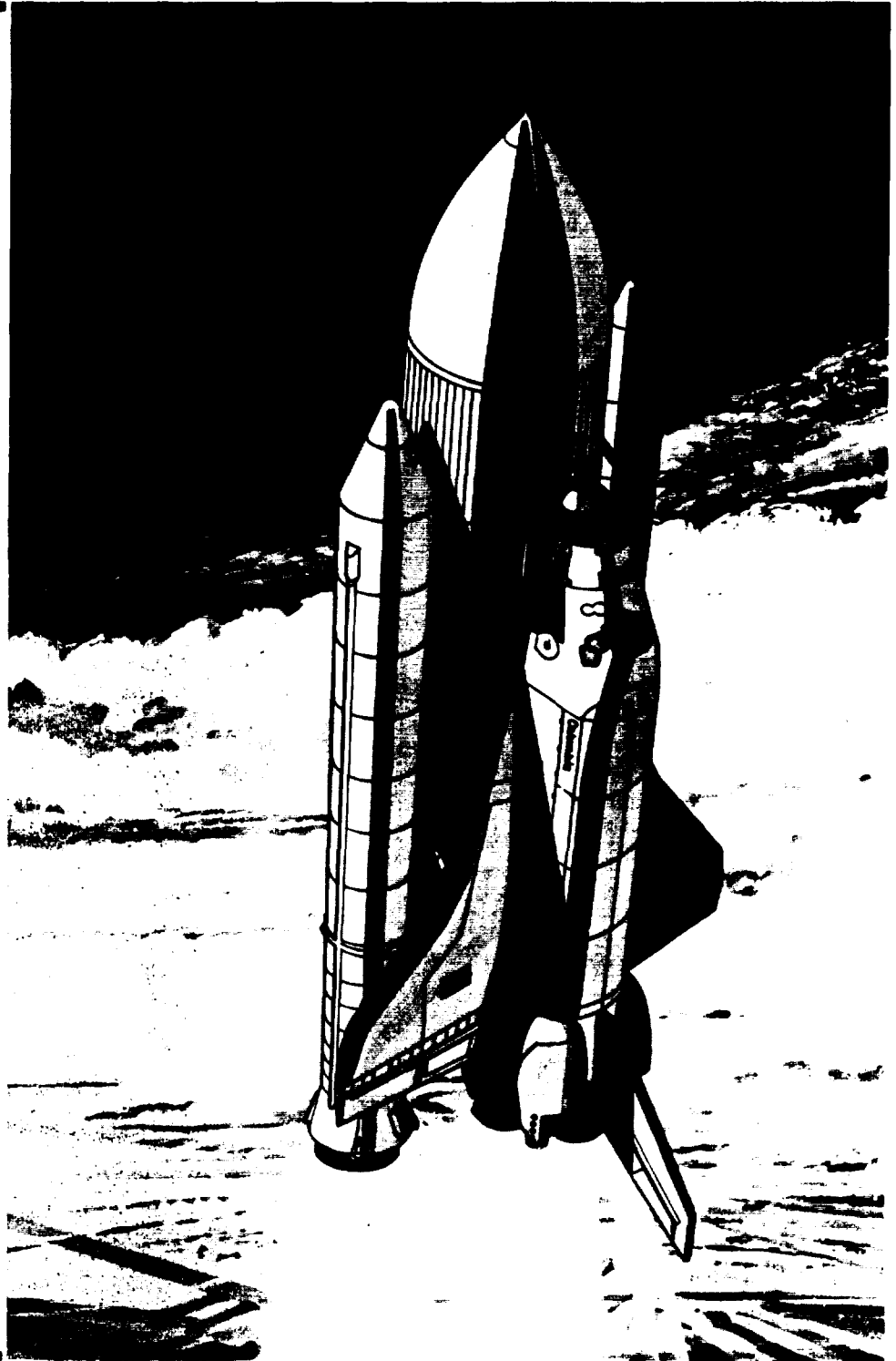

1. INTRODUCTION

reuse. The Shuttle can be used to carry out missions in which scientists and technicians conduct experiments in Earth orbit or service automated satellites already orbiting.

Development History

In September 1969, a few months after the first manned lunar landing, a Space Task Group appointed by the President of the United States to study the future course of U.S. space research and exploration made the recommendation that "... the United States accept the basic goal of a balanced manned and unmanned space program. To achieve this goal, the United States should ... develop new systems of technology for space operation ... through a program directed initially toward development of a new space transportation capability ..."

In early 1970, NASA initiated extensive engineering, design, and cost studies of a Space Shuttle. These studies covered a wide variety of concepts ranging from a fully reusable manned booster and orbiter to dual strap-on solid propellant rocket motors and an expendable liquid propellant tank. In-depth studies of each concept evaluated development risks and costs in relation to the operational suitability and the overall economics of the entire system.

The Space Shuttle is the prime element of the U.S. Space Transportation System (STS) (fig. 1-1) for space research and applications in future decades.

Satellites of all types will be deployed and recovered by the Shuttle. Carrying payloads weighing up to 29 500 kilograms (65 000 pounds), the Space Shuttle will replace most of the expendable launch vehicles currently used and will be capable of launching deep-space missions into their initial low Earth orbit. It will also provide the first system capable of returning payloads from orbit on a routine basis.

Shuttle crews will be able to retrieve satellites from Earth orbit and repair and redeploy them or bring them back to Earth for refurbishment and

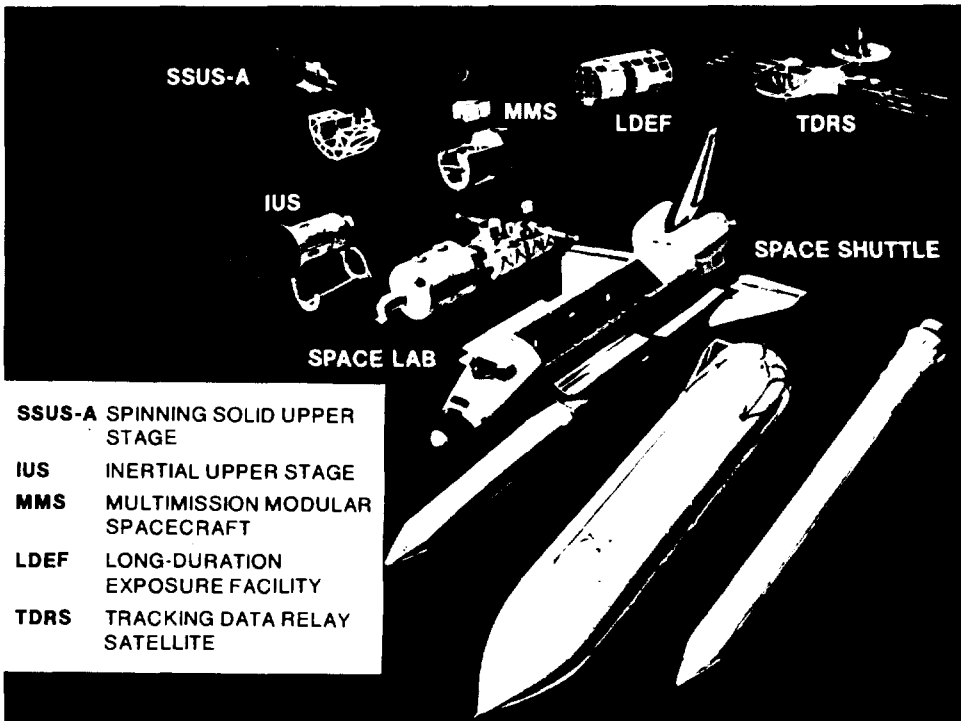

Figure 1-1.— The Space Transportation System.

On January 5, 1972, President Richard M. Nixon announced that NASA would proceed with the development of a reusable low-cost Space Shuttle system. NASA and its aerospace industry contractors continued engineering studies through January and February of 1972; finally, on March 15, 1972, NASA announced that the Shuttle would use two solid-propellant rocket motors. The decision was based on information developed by studies which showed that the solid rocket system offered lower development cost and lower technical risk.

A Versatile Vehicle

The Space Shuttle (fig. 1-2) is a true aerospace vehicle: it takes off like a rocket, maneuvers in Earth orbit like a spacecraft, and lands like an airplane. The Space Shuttle is designed to carry heavy loads into Earth orbit. Other launch vehicles have done this; however, unlike those vehicles which could be used just once, each Space Shuttle Orbiter may be reused more than 100 times.

The Shuttle permits the checkout and repair of unmanned satellites in orbit or their return to Earth for repairs that cannot be done in space. Thus, the Shuttle makes possible considerable savings in spacecraft cost. The types of satellites that the Shuttle can orbit and maintain include those involved in environmental protection, energy, weather forecasting, navigation, fishing, farming, mapping, oceanography, and many other fields useful to man.

Interplanetary spacecraft can be placed in Earth orbit by the Shuttle together with a rocket stage called the Inertial Upper Stage (IUS), which is being developed by the Department of Defense. After the IUS and the spacecraft are checked out, the IUS is ignited to accelerate the spacecraft into deep space. The IUS also will be used to boost satellites to higher Earth orbits than the Shuttle's maximum altitude, which is approximately 1000 kilometers (600 miles).

Unmanned satellites such as the Space Telescope, which can multiply man's view of the universe, and the Long-Duration Exposure Facility, which can demonstrate the effects on materials of long exposure to the space environment, can be placed in orbit, erected, and returned to Earth by the Space Shuttle. Shuttle

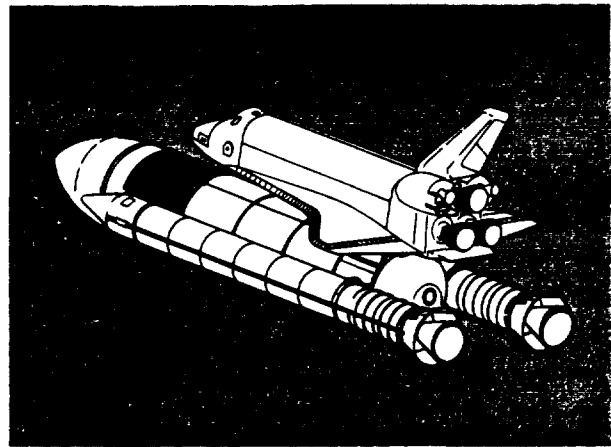

Figure 1-2.— The Space Shuttle vehicle.

crews also can perform such services as replacing the film packs and lenses on the Space Telescope.

The Shuttle Orbiter is a manned spacecraft, but, unlike manned spacecraft of the past, it touches down on a landing strip. The Shuttle thus eliminates the expensive recovery at sea that was necessary for the Mercury, Gemini, Apollo, and Skylab spacecraft.

The reusable Shuttle also has a short turnaround time. It can be refurbished and ready for another journey into space within weeks after landing.

The Shuttle can quickly provide a vantage point in space for observation of interesting but transient astronomical events or of sudden weather, agricultural, or environmental crises on Earth. Information from Shuttle observations would contribute to sound decisions for dealing with such urgent matters.

The Shuttle will also be used to transport a complete scientific laboratory called Spacelab into space. Developed by the European Space Agency, Spacelab is adapted to operate in zero gravity (weightlessness). Spacelab provides facilities for as many as four laboratory specialists to conduct experiments in such fields as medicine, manufacturing, astronomy, and pharmaceuticals. Spacelab remains attached to the Shuttle Orbiter throughout its mission. Upon return to Earth, it is removed from the Orbiter and outfitted for its next assignment. The Spacelab can be reused about 50 times.

The Space Shuttle will bring within reach projects that many considered impractical not too long ago. The Shuttle could carry into orbit the "building blocks" for constructing large solar power stations that would convert the unlimited solar heat and sunlight of space into electricity for an energy-hungry world. The components would be assembled by specialists transported to and supported in space by the Shuttle. The Shuttle could also carry into Earth orbit the modular units for self-sustaining settlements. The inhabitants of the settlements could be employed in building and maintaining solar power stations and in manufacturing drugs, metals, electronics crystals, and glass for lenses. Manufacturing in weightless space can, among other things, reduce the cost of certain drugs, create new alloys, produce drugs and lenses of unusual purity, and enable crystals to grow very large.

Space Shuttle Components

The Space Shuttle has three main units: the Orbiter, the External Tank (ET), and two Solid Rocket Boosters (SRB's) (fig. 1-3). Each booster rocket has a sea level thrust of 11 600 kilonewtons (2 600 000 pounds).

The Orbiter is the crew- and payload-carrying unit of the Shuttle system. It is 37 meters (121 feet) long, has a wingspan of 24 meters (79 feet), and weighs approximately 68 000 kilograms (150 000 pounds) without fuel. It is about the size and weight of a DC-9 commercial air transport.

The Orbiter can transport a payload of 29 500 kilograms (65 000 pounds) into orbit. It carries its cargo in a cavernous payload bay 18.3 meters (60 feet) long and 4.6 meters (15 feet) in diameter. The bay is flexible enough to provide accommodations for unmanned spacecraft in a variety of shapes and for fully equipped scientific laboratories.

The Orbiter's three main liquid rocket engines each have a thrust of 21 00 kilonewtons (470 000 pounds). They are fed propellants from the External Tank, which is 47 meters (154 feet) long and 8.7 meters (28.6 feet) in diameter. At lift-off, the tank holds 703 000 kilograms (1 550 000 pounds) of propellants, consisting of liquid hydrogen (fuel) and liquid oxygen (oxidizer). The hydrogen and oxygen are in separate pressurized compartments of the tank. The External Tank is the only part of the Shuttle system that is not reusable.

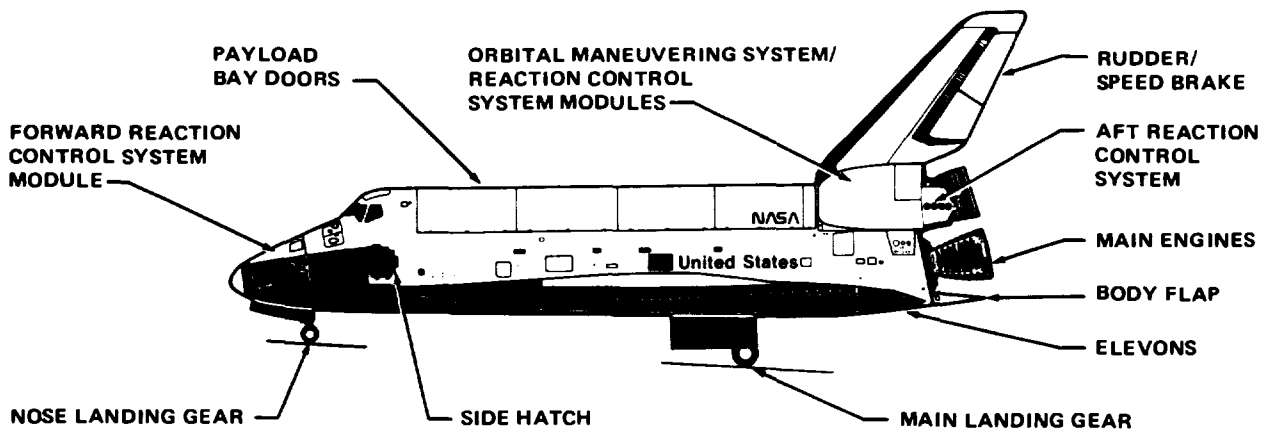
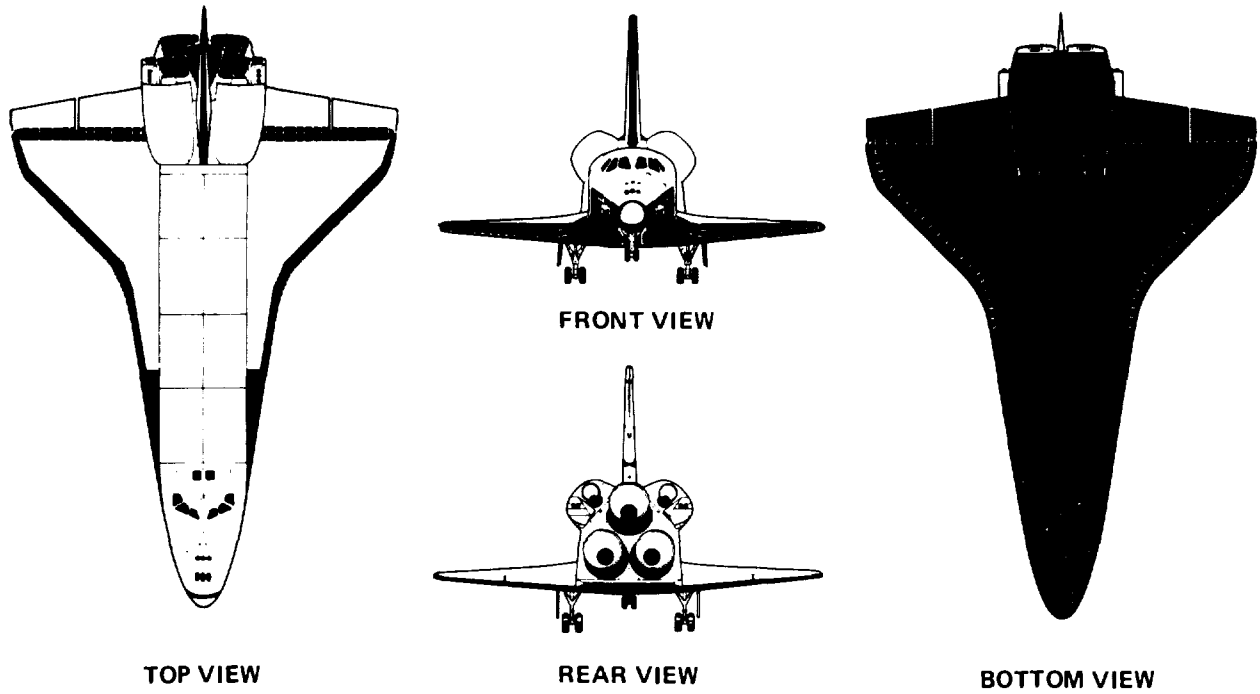

DIMENSIONS AND WEIGHT

WING SPAN	23.79 m	(78.06 FT)
LENGTH	37.24 m	(122.17 FT)
HEIGHT	17.25 m	(56.58 FT)
TREAD WIDTH	6.91 m	(22.67 FT)
GROSS TAKEOFF WEIGHT		VARIABLE
GROSS LANDING WEIGHT		VARIABLE
INERT WEIGHT (APPROX)	74 844 kg	(165 000 LB)

MINIMUM GROUND CLEARANCES

BODY FLAP (AFT END)	3.68 m	(12.07 FT)
MAIN GEAR (DOOR)	0.87 m	(2.85 FT)
NOSE GEAR (DOOR)	0.90 m	(2.95 FT)
WINGTIP	3.63 m	(11.92 FT)

Figure 1-3.— The Space Shuttle Orbiter.

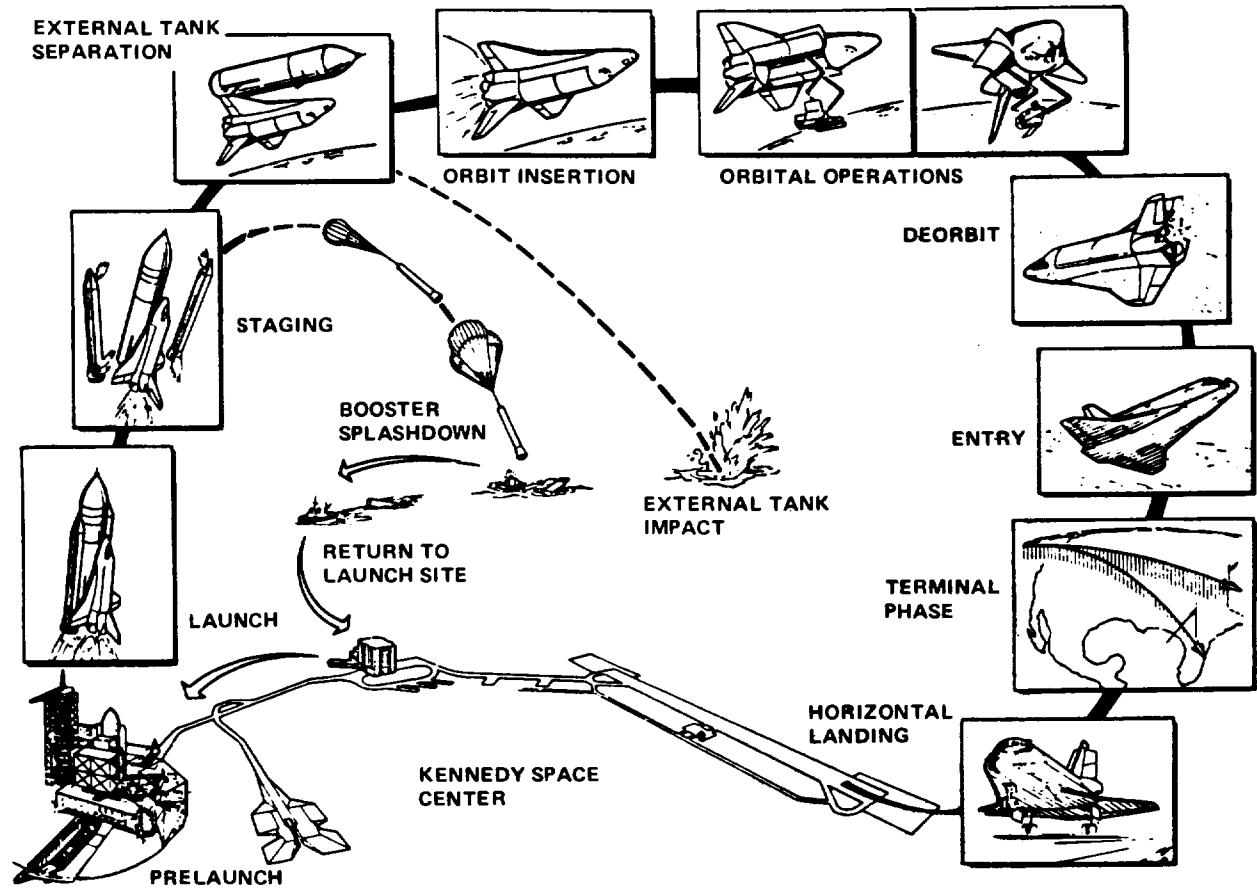

Figure 1-4.— A Space Shuttle typical mission profile.

Typical Shuttle Mission

In a typical Shuttle mission (fig. 1-4), which could last from 7 to 30 days, the Orbiter's main engines and the boosters ignite simultaneously to rocket the Shuttle from the launch pad. The Shuttle is launched from the NASA John F. Kennedy Space Center in Florida for east-west orbits or from Vandenberg Air Force Base in California for north-south orbits.

At a predetermined point, the two Solid Rocket Boosters separate from the Orbiter and parachute to the sea where they are recovered for reuse. The Orbiter continues into space and jettisons the external propellant tank just before orbiting. The External Tank enters the atmosphere and breaks up over a remote ocean area.

In orbit, the Orbiter uses its orbital maneuvering system (OMS) to adjust its path; to conduct rendezvous operations; and, at the end of the mission, to slow down for the return to Earth. The

OMS propellants, which ignite on contact, are monomethyl hydrazine as the fuel and nitrogen tetroxide as the oxidizer.

The Orbiter does not follow a ballistic path to the ground as did earlier manned spacecraft. It can maneuver to the right or left of its entry path as much as 2034 kilometers (1264 miles).

A special insulation that sheds heat so readily that one side is cool enough to hold in bare hands while the other side is red hot serves as the Orbiter heat shield. The insulation survives temperatures up to 1533 K (1260°C or 2300°F) for 100 flights with little or no refurbishment. Previous manned spacecraft used heat shields that charred to carry heat away during the fiery entry into the Earth's atmosphere.

The Orbiter touches down like an airplane on a runway at Kennedy Space Center or Vandenberg Air Force Base. The landing speed is approximately 335 km/hr (208 mph).



Figure 1-5.— A Space Shuttle flightcrew.

Crew

The Shuttle crew (fig. 1-5) can include as many as seven people: the commander; the pilot; the mission specialist, who is responsible for management of Shuttle equipment and resources supporting payloads during the flight; and one to four payload specialists, who are in charge of specific payload equipment. The commander, pilot, and mission specialist are NASA astronauts and are assigned by NASA. Payload specialists conduct the experiments and may or may not be astronauts. They are nominated by the payload sponsor and certified for flight by NASA.

2. SPACE TRANSPORTATION SYSTEM PROPULSION



2. SPACE TRANSPORTATION SYSTEM PROPULSION

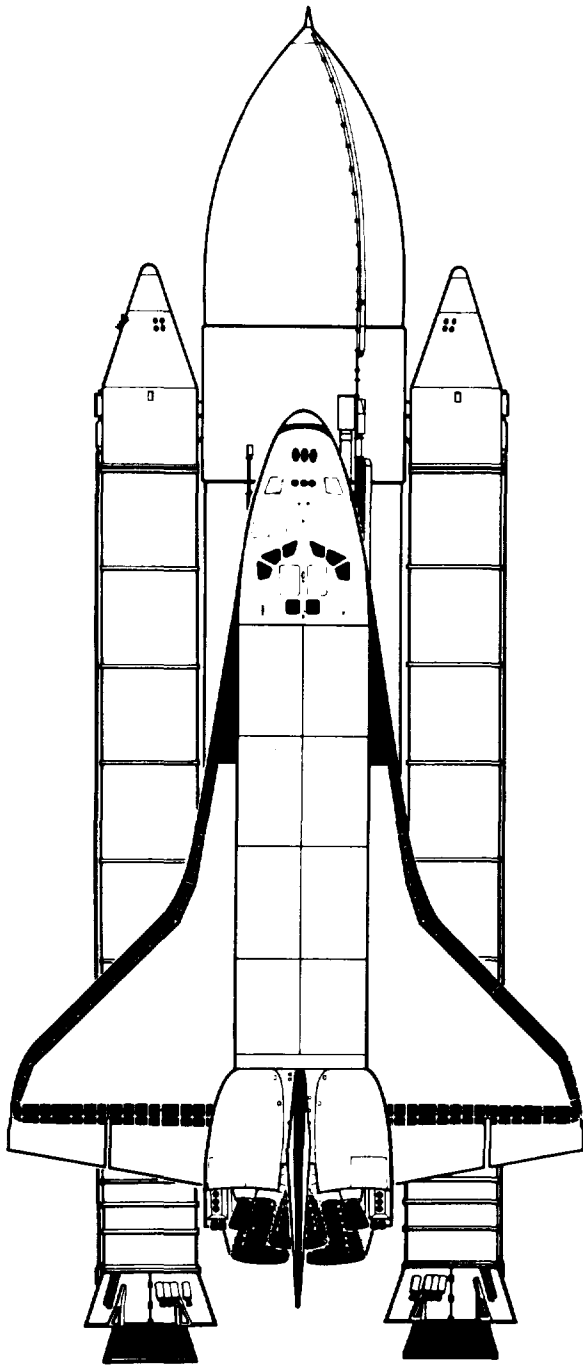

Space Shuttle Main Engines

OPERATION OF THE SPACE SHUTTLE	
MAIN ENGINES	2-5
COMBUSTION DEVICES	2-8
Ignition System	2-8
Preburners	2-8
Main Injector	2-9
Main Combustion Chamber	2-9
Nozzle Assembly	2-10
ENGINE SYSTEMS	
Hot-Gas Manifold	2-10
Heat Exchanger	2-11
Thrust Vectoring	2-11
Pneumatic Subsystem	2-11
TURBOPUMPS	
Propellant Feed System Summary	2-12
Fuel Turbopumps	2-12
Oxidizer Turbopumps	2-12
MAIN VALVES	
Main Oxidizer Valve	2-13
Main Fuel Valve	2-13
Oxidizer Preburner Oxidizer Valve	2-13
Fuel Preburner Oxidizer Valve	2-13
Chamber Coolant Valve	2-13
HYDRAULIC SUBSYSTEM	
CONTROLLER	
Controller Functional Organization	2-15
Controller Software	2-15

Briefly . . .

The three main engines of the Space Shuttle, in conjunction with the Solid Rocket Boosters, provide the thrust to lift the Orbiter off the ground for the initial ascent. The main engines operate for approximately the first 8.5 minutes of flight.

THRUST

Sea level: 1670 kilonewtons (375 000 pounds)

Vacuum: 2100 kilonewtons (470 000 pounds)

(Note: Thrust given at rated or 100-percent power level.)

THROTTLING ABILITY

65 to 109 percent of rated power level

SPECIFIC IMPULSE

Sea level: $356.2 \frac{\text{N/s}}{\text{kg}}$ ($363.2 \frac{\text{lb/s}}{\text{lbm}}$)

Vacuum: $446.4 \frac{\text{N/s}}{\text{kg}}$ ($455.2 \frac{\text{lb/s}}{\text{lbm}}$)

(Given in newtons per second to kilograms of propellant and pounds-force per second to pounds-mass of propellant)

CHAMBER PRESSURE

20 480 kN/m² (2970 psia)

MIXTURE RATIO

6 parts liquid oxygen to 1 part liquid hydrogen (by weight)

AREA RATIO

Nozzle exit to throat area 77.5 to 1

WEIGHT

Approximately 3000 kilograms (6700 pounds)

LIFE

7.5 hours, 55 starts

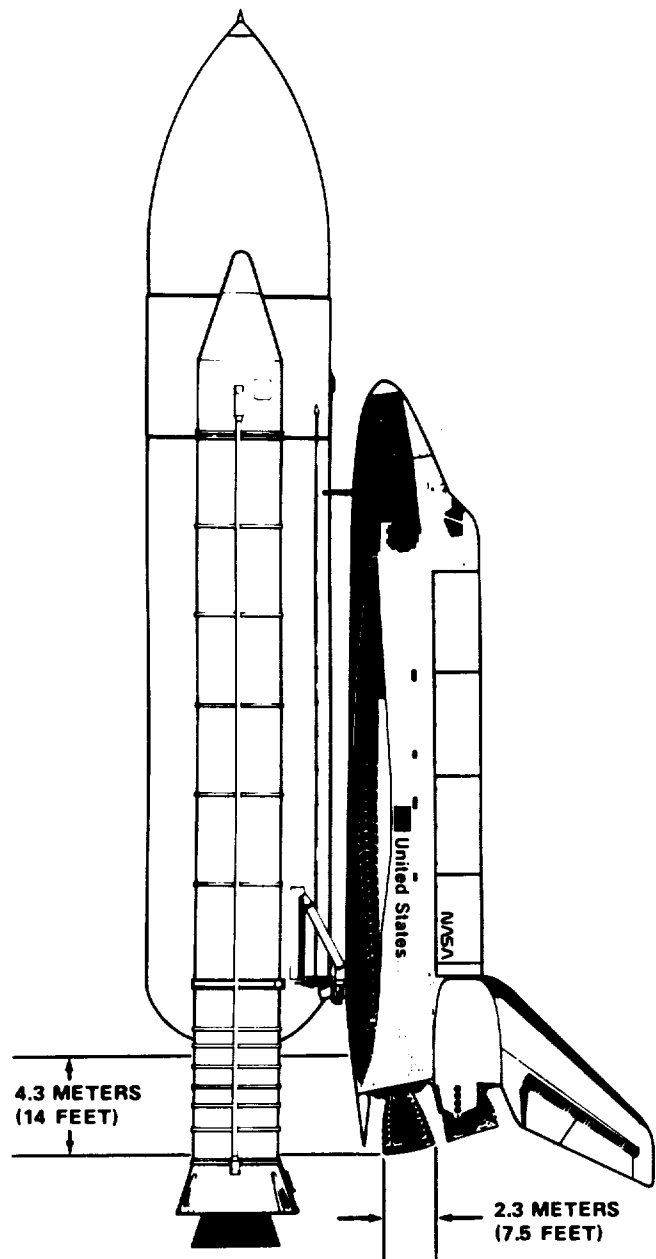

2. SPACE TRANSPORTATION SYSTEM PROPULSION

Space Shuttle Main Engines

A cluster of three Space Shuttle Main Engines (SSME's) (figs. 2-1 and 2-2) provides the main propulsion for the Orbiter vehicle. The liquid hydrogen/liquid oxygen engine is a reusable high-performance rocket engine capable of various thrust levels. Ignited on the ground prior to launch, the cluster of three main engines operates in parallel with the Solid Rocket Boosters (SRB's) during the initial ascent. After the boosters separate, the main engines continue to operate. The nominal operating time is approximately 8.5 minutes.



Figure 2-1.—Space Shuttle Main Engines (MSFC 002382).

The main engines develop thrust by using high-energy propellants in a staged combustion cycle (fig. 2-3). The propellants are partially combusted in dual preburners to produce high-pressure hot gas to drive the turbopumps. Combustion is completed in the main combustion chamber. The cycle ensures maximum performance because it eliminates parasitic losses.

Each Space Shuttle Main Engine operates at a liquid oxygen/liquid hydrogen mixture ratio of 6 to 1 to produce a sea level thrust of 1 668 kilonewtons (375 000 pounds) and a vacuum thrust of 2091 kilonewtons (470 000 pounds). The engines can be throttled over a thrust range of 65 to 109 percent, which provides for a high thrust level during lift-off and the initial ascent phase but allows thrust to be reduced to limit acceleration to 3g's during the final ascent phase. The engines are gimballed to provide pitch, yaw, and roll control during the Orbiter boost phase.

Modified airline maintenance procedures will be used to service the engine without removing it from the vehicle between flights. Most engine components can be replaced in the field as line replacement units without extensive engine recalibration or hot-fire testing. These procedures result in an economical and efficient turnaround method.

OPERATION OF THE SPACE SHUTTLE MAIN ENGINES

The flow of liquid hydrogen and liquid oxygen from the External Tank (ET) is restrained from entering the engine by prevalues located in the Orbiter above the low-pressure turbopumps (fig. 2-3, nos. 1 and 11). Before firing, the prevalues are opened to allow propellants to flow through the low-pressure turbopumps (1 and 11) and the high-pressure turbopumps (2 and 12) and then to the main propellant valves (3 and 13). On the liquid oxygen side, the system also fills to preburner valves (7 and 14). The cryogenic propellants are held in the ducts for sufficient time to chill the engine and attain liquid conditions in the respective propellant systems. The chill process is aided by bleedlines (not shown) that allow circulation of the propellants.

In the start sequence, the hydrogen and oxygen sides operate almost simultaneously. On the hydrogen (fuel) side, the ignition command from the Orbiter opens the main fuel valve (3). This permits hydrogen to flow into the coolant loop, through the nozzle tubes (5), and through channels in the main combustion chamber (6). Part of this coolant loop flow is diverted by the coolant control valve (4) to the preburners (8 and 15). Some of the hydrogen used in the coolant loop is warmed in the process to virtually ambient conditions and is tapped off at the main combustion chamber (6) and routed back to the low-pressure turbopump (1) to drive the turbine for that pump. This flow passes through the turbine and is returned to the walls of the two preburners (8 and 15) where it cools the preburners, the hot-gas manifold (9), and the main injector (10).

On the oxygen (or oxidizer) side, the ignition command opens the main oxidizer valve (13). The liquid oxygen flows through the two turbopumps (11 and 12) to the main injector (10) and also

(through valves 7 and 14) to the two preburners (8 and 15). Oxygen, tapped off downstream of the high-pressure oxidizer turbopump (12), is routed to the low-pressure turbopump (11) to drive the liquid turbine for that pump. This flow continues through the low-pressure oxidizer turbopump (11), thus reentering the circuit.

Spark igniters located in the dome of both preburners (8 and 15) and the main chamber (10) initiate combustion. The two preburners are operated at mixture ratios of less than one part oxygen to one part hydrogen to produce hot gas (or hydrogen-rich steam). The hot gas or steam is used to drive the turbines of the two high-pressure turbopumps (2 and 12) before entering the hot-gas manifold (9). This hydrogen-rich steam is transferred by the hot-gas manifold (9) from the turbines to the main injector (10) where it is mixed with additional liquid oxygen from the high-pressure oxidizer turbopump (12) for combustion. This combustion process is completed at a mixture ratio of six parts oxygen to one part hydrogen.

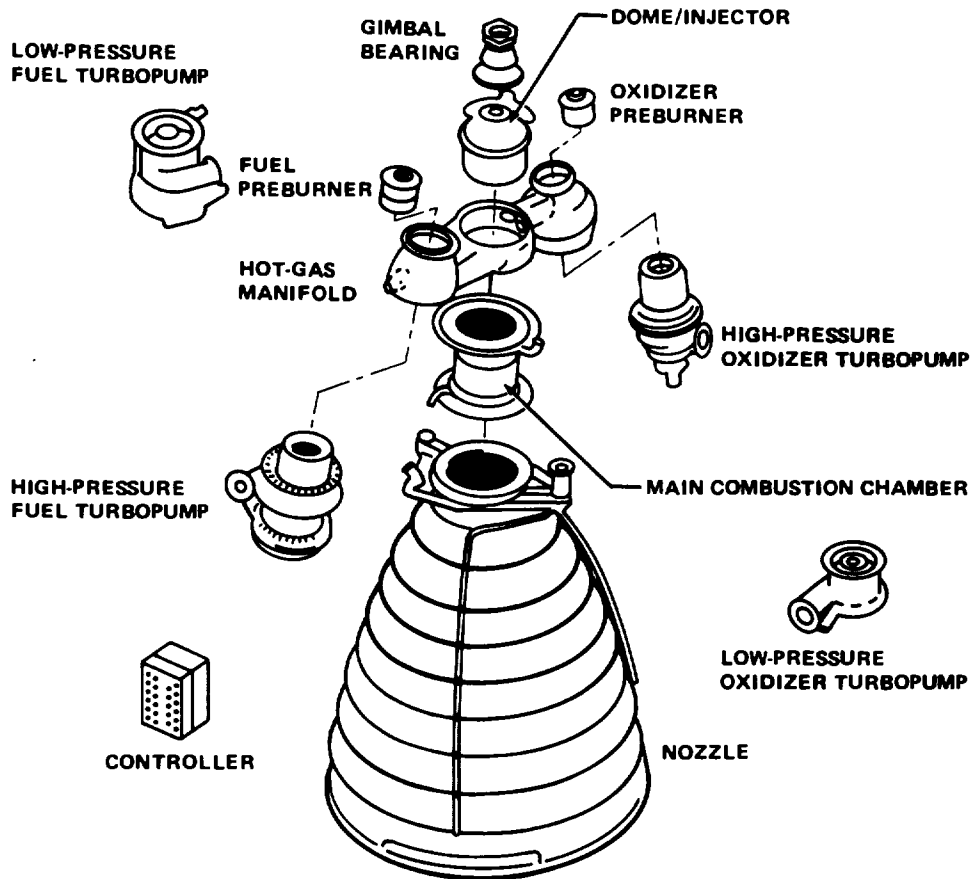

Figure 2-2.—SSME major components.

Two additional components of the engine should also be mentioned. The pogo suppressor (16) is provided to absorb any closed-loop longitudinal dynamic oscillations that might be generated between the vehicle structural dynamics and the engine combustion process. A suppressor is not required on the hydrogen side of the engine because the low density of that fluid has been shown to be insufficient to transmit any appreciable dynamic oscillations.

Another major component of the engine, not shown in figure 2-3, is the controller, which operates all engine controls. Mounted on the

engine, the controller includes a computer to integrate commands received from the Orbiter with data input from sensors located on the engine. The controller monitors the engine before ignition, controls purges before and during operation of the engine, manages the engine's redundancy features, receives and transmits data to the Orbiter for either storage or transmission to the ground, and operates the engine control valves. The five control valves numbered 3, 4, 7, 13, and 14 in figure 2-3 effectively control the entire engine operation.

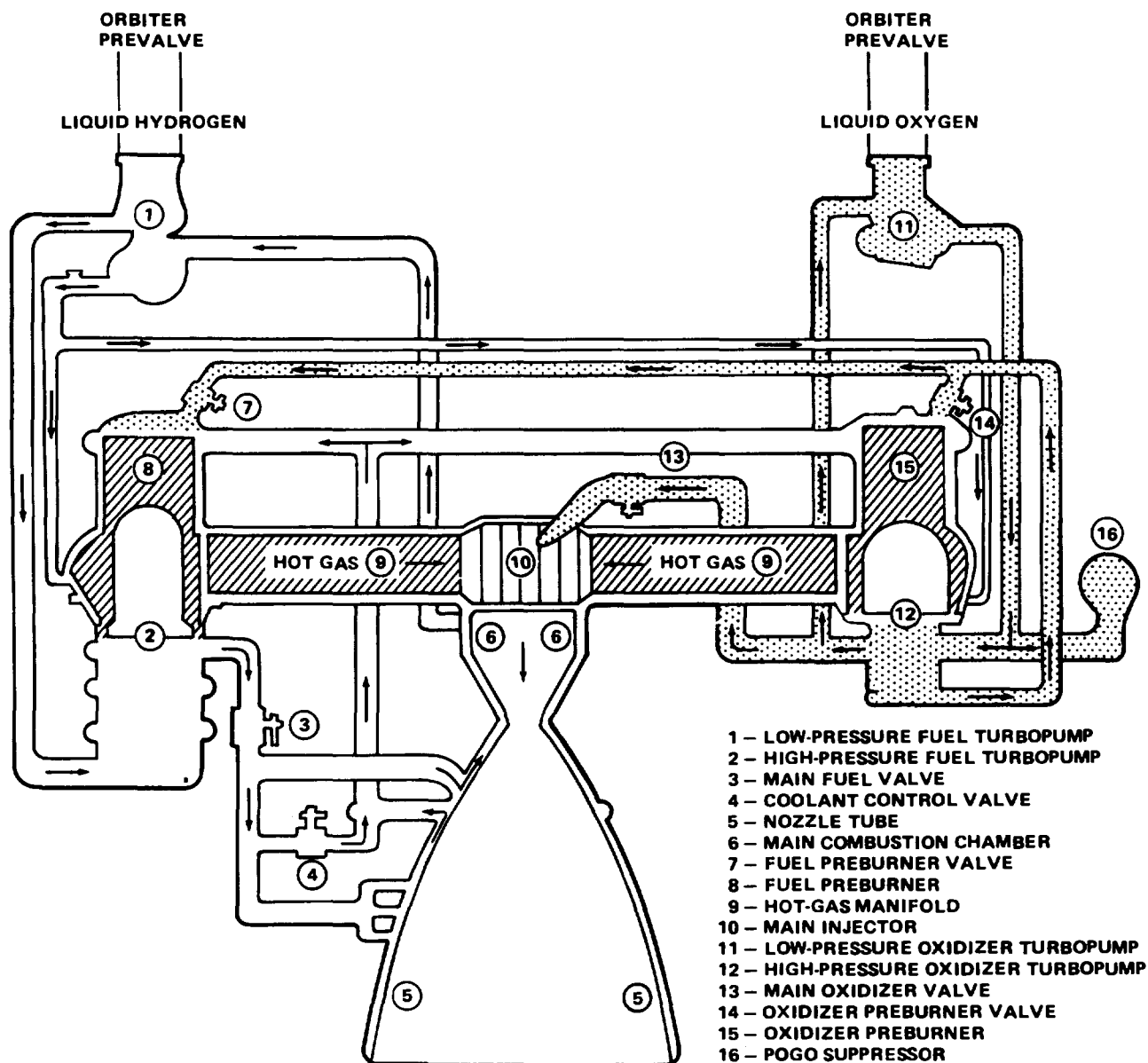

Figure 2-3.—SSME propellant flow schematic.

COMBUSTION DEVICES

Combustion devices are located in those parts of the engine where controlled combustion, or burning, of the liquid oxygen and liquid hydrogen occurs. The five major components in this group are the ignition system, the preburners, the main injector, the main combustion chamber, and the nozzle assembly (fig. 2-4).

Ignition System

The ignition system starts the combustion process in the main engine. There are three ignition units, one for the main chamber injector and one for each of the two preburner injectors. Each ignition unit, located in the center of its respective injector, includes a small combustion chamber, two spark igniters (similar to spark plugs), and propellant supply lines. At engine start, all six spark igniters are activated, igniting the propellants as they enter the igniter combustion chamber and thus providing an

ignition source for propellants entering the preburners and the main combustion chamber. The ignition unit remains active for the duration of engine operation, but the spark igniters are turned off after ignition is complete.

Preburners

Each main engine has fuel and oxidizer preburners that provide hydrogen-rich hot gases at approximately 1030 K (760° C or 1400° F). These gases drive the fuel and oxidizer high-pressure turbopumps. The preburner gases pass through turbines and are directed through a hot-gas manifold to the main injector where they are injected into the main combustion chamber together with liquid oxygen and burn at approximately 3590 K (3315° C or 6000° F).

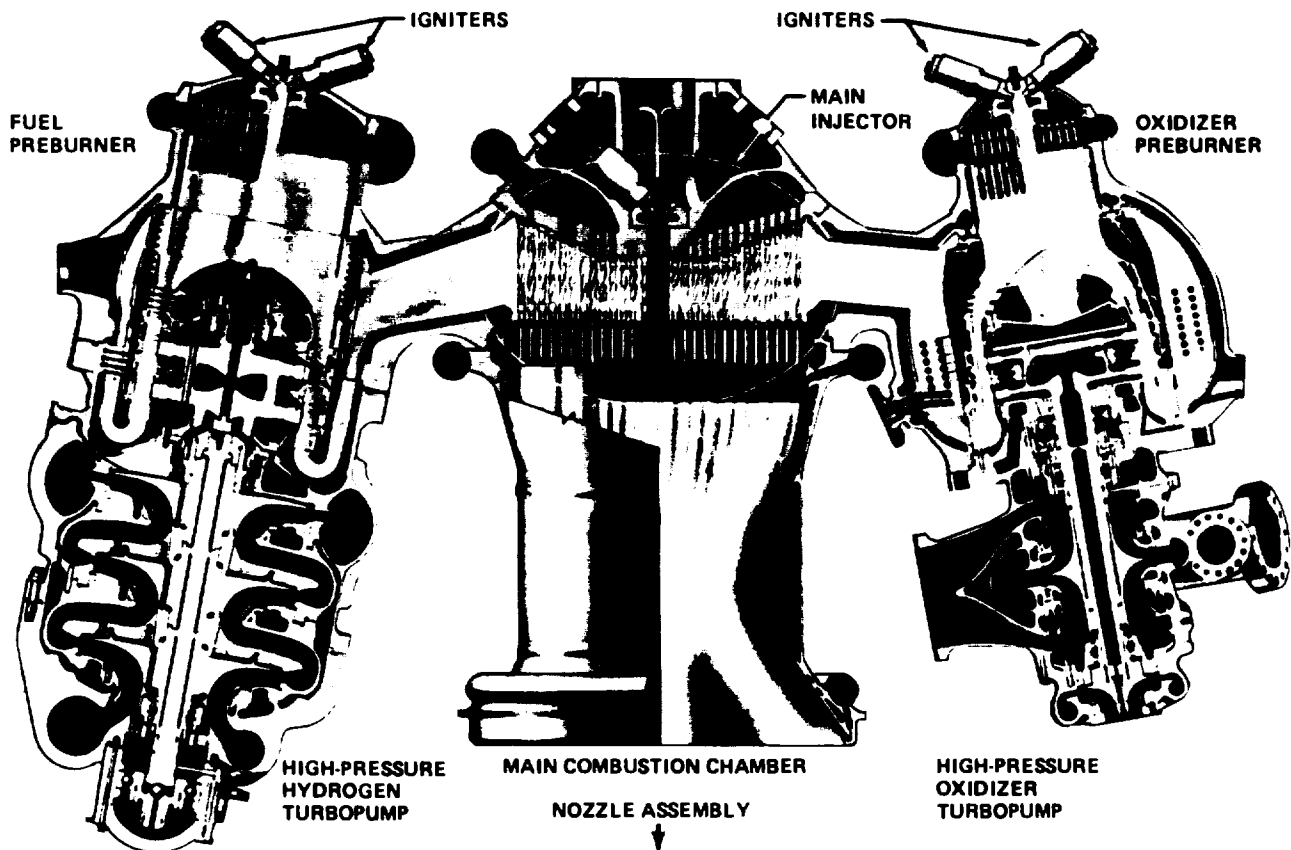

Figure 2-4.—SSME powerhead component arrangement.

The design of the two preburners is similar. Each consists of fuel and oxidizer supply manifolds, an injector, stability devices, a cylindrical combustion zone, and an ignition unit. The supply manifolds ensure uniform propellant distribution so that each injector element receives the correct amount of oxygen and hydrogen. The preburner injectors consist of many individual injection elements that introduce the propellants in concentric streams. Each oxygen stream is surrounded by its companion hydrogen stream. The injector contains baffles to help maintain stable combustion in the preburners and thus suppress disturbances that might occur in the combustion process. Gaseous hydrogen flows through passages in each baffle for cooling and is then discharged into the combustion chamber.

The cylindrical combustion zone consists of a structural shell and a thin inner liner. The liner is cooled by passing gaseous hydrogen between it and the structural wall.

Main Injector

The main injector performs the vital function of finally mixing all the liquid oxygen and liquid hydrogen together as thoroughly and uniformly as possible to produce efficient combustion.

An intricately fabricated component, the main injector consists of a thrust cone, an oxidizer supply manifold, two fuel cavities, 600 injection elements, and an ignition unit. The thrust cone transmits the total thrust of the engine through the gimbal bearing to the Orbiter vehicle. The oxidizer supply manifold receives oxygen from the high-pressure turbopump and distributes it evenly to the 600 injection elements. One of the two fuel cavities supplies the fuel-rich hot gases that originate in the preburners and are used to run the high-pressure turbines. The other fuel cavity supplies gaseous hydrogen from the hot-gas manifold cooling circuit.

The 600 main injector elements have the same basic design as the preburner injection elements; i.e., an outer fuel shroud that surrounds a central oxidizer stream. The propellants are thoroughly mixed as they are introduced into the main combustion zone for burning at approximately 3590 K (3315° C or 6000° F).

Seventy-five of the injection elements also form baffles that divide the injector into six compartments. The baffles are designed to suppress any pressure disturbances that might occur during the combustion process.

Main Combustion Chamber

The main combustion chamber is a double-walled cylinder between the hot-gas manifold and the nozzle assembly. Its primary function is to receive the mixed propellants from the main injector, accelerate the hot combusted gases to sonic velocity through the throat, and expand them supersonically through the nozzle. The main chamber operating pressure at rated power level is approximately 20 700 kN/m² (3000 psi). The main combustion chamber consists of a coolant liner, a high-strength structural jacket, coolant inlet and outlet manifolds, and actuator struts.

The internal contour of the coolant liner forms the typical contraction-throat-expansion shape common to conventional rocket engine combustion chambers. The contraction area ratio (the ratio of the area at the injector face to the throat area) is 2.96 to 1. The expansion area ratio (the ratio of the area at the aft end of the combustion chamber to the throat area) is 5 to 1. The contraction contour is shaped to minimize the transfer of heat from the combustion gases to the coolant liner. The expansion contour accelerates the combustion gases to the 5-to-1 expansion ratio with minimum energy loss.

The coolant liner passes hydrogen coolant (fuel) through 390 channels. Approximately 25 percent of the total hydrogen flow is used to cool the liner. The chamber jacket goes around the outside of the liner to provide structural strength. Inlet and outlet coolant manifolds are welded to the jacket and to the liner. Two actuator struts are bolted to the chamber and are used, in conjunction with hydraulic actuators, to gimbal the engine during flight when it is necessary to change the direction of the thrust.

Nozzle Assembly

To provide maximum possible thrust efficiency, the nozzle assembly (fig. 2-5) allows continued expansion of the combustion gases coming from the main combustion chamber. It is designed for a 77.5-to-1 thrust chamber expansion ratio for thrust efficiency at high altitudes. The nozzle assembly is the largest component on the engine, measuring approximately 3 meters (10 feet) in length and 2.4 meters (8 feet) in diameter at the base. The nozzle assembly consists of a forward manifold subassembly and a stacked tube nozzle subassembly.

The forward manifold subassembly provides the attachment to the main combustion chamber. It also distributes hydrogen to the main chamber and nozzle cooling circuits and to both the fuel and oxidizer preburners.

The stacked tube nozzle subassembly contains 1080 tubes brazed together to form the desired contour. They are connected at the aft end to a coolant inlet manifold and at the forward end to a coolant outlet manifold. Hydrogen passes through the tubes and again provides a cooling function. The nozzle tubes are enclosed in a reinforced structural jacket. The jacket reinforcements (hatbands) are insulated for protection against the extreme heat encountered during launch and reentry.

ENGINE SYSTEMS

Hot-Gas Manifold

The hot-gas manifold (see fig. 2-2) is a double-walled, hydrogen-gas-cooled structural support and fluid manifold. It is the structural backbone of the engine and interconnects and supports the preburners, high-pressure turbopumps, main combustion chamber, and main injector.

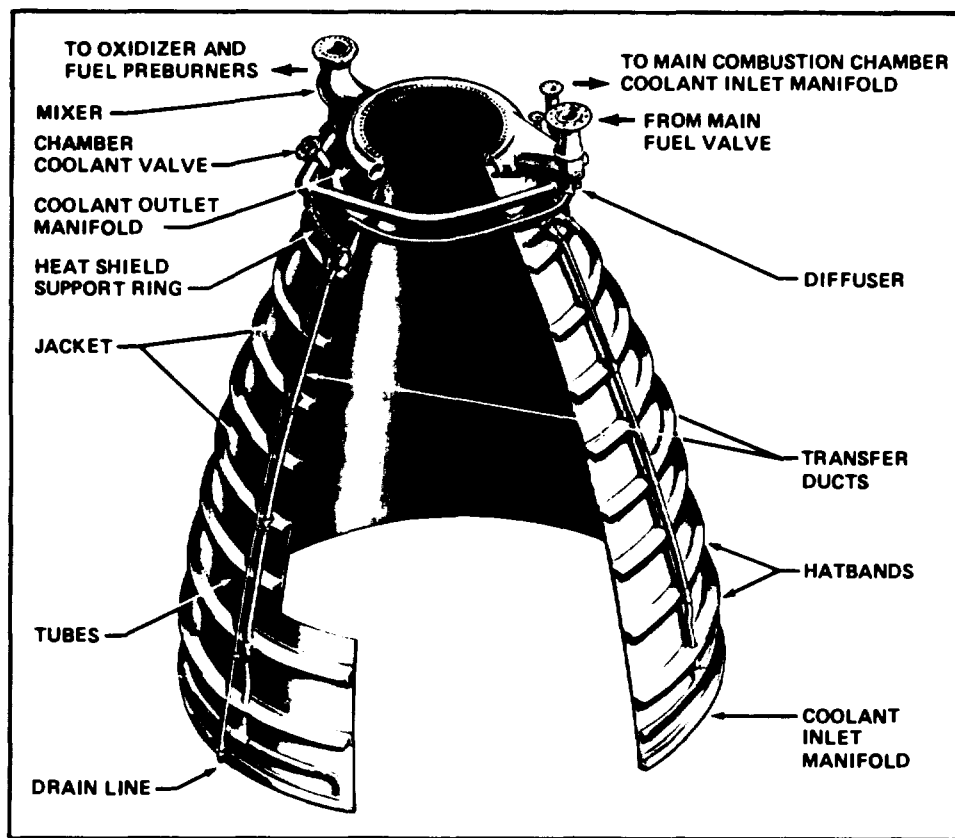

Figure 2-5.—SSME nozzle assembly.

The hot-gas manifold conducts hot gas (hydrogen-rich steam) from the turbines to the main chamber injector. The area between the wall and the liner provides a coolant flow path for the hydrogen gas that is exhausted from the low-pressure fuel turbopump turbine. This protects the outer wall and liner against the temperature effects of the hot gas from the preburners. After cooling the manifold, the hydrogen also serves as coolant for the primary faceplate, the secondary faceplate, and the main combustion chamber acoustic cavities. The high-pressure turbopumps are stud-mounted to the canted flanges on each side of the hot-gas manifold. The preburners are welded to the upper end of each side of the hot-gas manifold above the high-pressure turbopumps.

Heat Exchanger

The heat exchanger is a single-pass coil pack installed in the oxidizer side of the hot-gas manifold. It converts liquid oxygen to gaseous oxygen for vehicle oxygen tank and pogo-system accumulator pressurization. The heat exchanger consists of a helically wound small tube approximately 0.8 meter (2.6 feet) long, in series with two parallel larger tubes, each approximately 7.9 meters (25.8 feet) long. The tubes are attached to supports welded to the inner wall of the hot-gas manifold coolant jacket. The hot turbine exhaust gases from the high-pressure oxidizer turbopump heat the liquid oxygen to a gas. Liquid oxygen, tapped off the discharge side of the high-pressure oxidizer turbopump, is supplied to the inlet of the heat exchanger through an antiflood valve.

The oxygen is heated to a gas in the small tube (first stage) and to the final outlet temperature in the two larger tubes (second stage). An orificed bypass line around the heat exchanger injects an unheated portion (approximately 30 percent) of the total oxygen flow into the outlet of the heat exchanger for control of temperature and flow-rate operating characteristics. Orifices in the heat exchanger bypass line and in the vehicle control heat exchanger flow rate.

Thrust Vectoring

The gimbal bearing assembly is a spherical low-friction universal joint that has ball and socket bearing surfaces. The bearing assembly provides the mechanical interface with the vehicle for transmitting thrust loads and permits angulation of the actual thrust vector (force) about each of two vector control axes. The gimbal bearing is attached to the engine main injector by bolts that allow lateral positioning of the bearing. The gimbal bearing position is established by optical alignment during engine buildup to ensure that the actual thrust vector is within 30 minutes of arc to the engine centerline and 1.5 centimeters (0.6 inch) of the gimbal center. Cycle life is obtained by low-friction antigalling bearing surfaces that operate under high loads.

Pneumatic Subsystem

The pneumatic control assembly provides (1) control of ground-supplied gaseous nitrogen used for engine prestart purges and of vehicle-supplied helium for the operational purge, (2) control of the oxidizer and fuel bleed valves, and (3) emergency shutdown control of the main propellant valves in the event of electrical power loss to the engine. The pneumatic control assembly consists of a ported manifold to which solenoid valves and pressure-actuated valves are attached.

The oxidizer and fuel bleed valves are opened by pneumatic pressure from the pneumatic control assembly during engine-start preparation to provide a recirculation flow for propellants through the engine to ensure that the propellants are at the required temperatures for engine start. At engine start, the valves are closed by venting the actuation pressure.

The pneumatic control system purge check valves are spring-loaded normally closed poppet valves that isolate propellants from the pneumatic systems. The check valves are opened by pressure actuation.

TURBOPUMPS

Propellant Feed System Summary

The propellant feed system includes four turbopumps, two of which are low pressure and two high pressure. There is one of each for the liquid hydrogen fuel and liquid oxygen oxidizer. All four are line replaceable units for maintenance purposes.

Fuel Turbopumps

The low-pressure fuel turbopump is an axial-flow (inline) pump driven by a two-stage turbine. It raises the pressure of the fluid being applied to the high-pressure fuel pump to prevent cavitation, the formation of partial vacuums in a flowing liquid. The rotor assembly is supported on three ball bearings, which are cooled internally by liquid hydrogen. The low-pressure fuel turbopump nominally operates at a speed of 14 700 rpm, develops 1790 kilowatts (2400 brake horsepower) of power, and increases the pump pressure from 207 to 1600 kN/m² (30 to 232 psia) at a flow rate of 67 kg/s (147 lb/s). The turbine is driven by gaseous hydrogen at a nominal inlet pressure of 29 434 kN/m² (4269 psia).

The high-pressure fuel turbopump is a three-stage centrifugal pump driven directly by a two-stage turbine. The latter, in turn, is driven by hot gas supplied by the fuel preburner. Fuel flows in series through the three impellers from the pump inlet to the pump outlet and the flow is redirected between impellers by interstage diffusers. Two double sets of ball bearings support the rotating assembly. A thrust bearing at the pump end of the rotating assembly provides axial rotor thrust control during startup and shutdown, while a dynamic self-compensating balance system balances axial forces during mainstage operation. The bearings are cooled internally with liquid hydrogen. Two dynamic seals are used to prevent turbine-to-pump leakage.

The high-pressure fuel pump is a high-speed high-power turbopump that operates at a nominal speed of 35 000 rpm and develops 46 435 kilowatts (62 270 brake horsepower) of power. It increases the pump pressure from 1213 to 42 817 kN/m² (176 to 6210 psia) at a flow rate of

67 kg/s (147 lb/s). The nominal turbine inlet pressure and temperature are 35 605 kN/m² (5164 psia) and 961 K (688° C or 1271° F), respectively.

Oxidizer Turbopumps

The low-pressure oxidizer turbopump is an axial-flow pump that is driven by a six-stage turbine and powered by oxidizer propellant. Because the pump and turbine propellants are both liquid oxygen, the requirements for dynamic seals, purges, and drains have been eliminated. The primary function of the low-pressure oxidizer pump is to maintain sufficient inlet pressure to the high-pressure oxidizer pump to prevent cavitation. The rotor assembly is supported by two ball bearings, which are cooled internally with oxidizer. Turbine-drive fluid at 30 944 kN/m² (4488 psia) is provided from the high-pressure oxidizer pump discharge. The low-pressure oxidizer pump nominally operates at a speed of 5150 rpm, develops 1096 kilowatts (1470 brake horsepower), and increases the pump pressure from 690 to 2861 kN/m² (100 to 415 psia) at a flow rate of 401 kg/s (883 lb/s).

The high-pressure oxidizer turbopump consists of a main pump, which provides liquid oxygen to the main injector, and a boost pump, which supplies liquid oxygen to the preburners. The main pump has a single inlet and flow is split to a double-entry impeller with a common discharge. Two double sets of ball bearings support the rotor assembly and are cooled internally with liquid oxygen. Dynamic seals within the turbopump prevent the mixing of liquid oxygen and turbine gases. The turbopump rotor axial thrust is balanced by a self-compensating balance piston.

The high-pressure oxidizer turbine is powered by hot gas generated by the oxidizer preburner. This gas passes through the turbine blades and nozzles and discharges into the hot-gas manifold. The turbine housing is cooled by gaseous hydrogen supplied by the oxidizer preburner coolant jacket.

The high-pressure oxidizer turbopump is a high-speed high-power turbopump that operates at a nominal speed of 29 057 rpm with a turbine inlet pressure and temperature of 36 046 kN/m² (5228 psia) and 817 K (544° C or 1011° F), respectively. The main oxidizer pump develops 15 643 kilowatts (20 977 brake horsepower) of power with a pump pressure increase from 2482 to 31 937 kN/m² (360 to 4632 psia) at a flow rate of 484 kg/s (1066 lb/s). The preburner pump pressure increases from 30 592 to 52 642 kN/m² (4437 to 7635 psia) at a flow rate of 39 kg/s (86 lb/s) with 1098 kilowatts (1472 brake horsepower) of power.

MAIN VALVES

The main propellant valves consist of the main oxidizer valve, the main fuel valve, the oxidizer preburner oxidizer valve, the fuel preburner oxidizer valve, and the chamber coolant valve. All except the chamber coolant valve are ball-type valves and have two major moving components, the integral ball-shaft cams and the ball-seal retracting mechanism. The ball inlet seal is a machined plastic, bellows-loaded, closed seal. Redundant shaft seals, with an overboard drain cavity between them, prevent leakage along the shaft (actuator end) during engine operation. Inlet and outlet sleeves align the flow to minimize turbulence and the resultant pressure loss. Ball seal wear is minimized by cams and a cam-follower assembly that moves the seal away from the ball when the valve is being opened.

All valves are operated by a hydraulic servoactuator mounted to the valve housing and receive electrical control signals from the engine controller.

Main Oxidizer Valve

The main oxidizer valve has a 6.4-centimeter (2.5-inch) propellant flow passage and is flange-mounted between the main chamber oxidizer dome and the high-pressure oxidizer duct. The valve controls oxidizer flow to the main chamber liquid oxygen dome and the main chamber augmented spark igniter.

Main Fuel Valve

The main fuel valve has a 6.4-centimeter (2.5-inch) propellant flow passage and is flange-mounted between the high-pressure fuel duct and the coolant inlet distribution manifold on the thrust chamber nozzle. It controls the flow of fuel to the thrust chamber coolant circuits, the low-pressure fuel turbopump turbine, the hot-gas-manifold coolant circuit, the oxidizer preburner, the fuel preburner, and the three augmented spark igniters.

Oxidizer Preburner Oxidizer Valve

The oxidizer preburner oxidizer valve has a 2.8-by 0.724-centimeter (1.1 - by 0.285-inch) propellant flow slot. It is flange-mounted between the oxidizer supply line to the oxidizer preburner and the oxidizer preburner oxidizer inlet. This valve controls the flow of oxidizer to the oxidizer preburner and the oxidizer preburner augmented spark igniter. During mainstage operation, the valve is modulated to control engine thrust between minimum and full power levels.

Fuel Preburner Oxidizer Valve

The fuel preburner oxidizer valve has a 2.8-centimeter (1.1-inch) propellant flow passage. It is flange-mounted between the oxidizer supply line to the fuel preburner and the fuel preburner oxidizer inlet. This valve controls the flow of oxidizer to the fuel preburner and the fuel preburner augmented spark igniter. During mainstage operation, the valve is modulated to maintain the desired engine mixture ratio.

Chamber Coolant Valve

The chamber coolant valve is a gate-type valve that serves as a throttling control to maintain proper fuel flow through the main combustion chamber and nozzle coolant circuits. It is installed in the chamber coolant valve duct, which is an integral component of the nozzle forward manifold assembly and provides housing for the valve.

The gate has a 4.1-centimeter (1.6-inch) flow passage. The chamber coolant valve does not have a gate seal since it is located downstream from the main fuel valve and is not required to be a positive shutoff valve. Redundant shaft seals, with an overboard drain cavity between them, prevent leakage along the shaft (actuator end) during engine operation.

HYDRAULIC SUBSYSTEM

Hydraulic power is provided by the Orbiter for the operation of five valves in the propellant feed system: the oxidizer preburner oxidizer, fuel preburner oxidizer, main oxidizer, main fuel, and chamber coolant valves. Servoactuators mounted to the propellant valves convert vehicle-supplied hydraulic fluid pressure to the rotary motion of the actuator shaft by electrical input command.

Two servovalves, which are integral with each servoactuator, convert the electrical command signal from the engine controller to hydraulic flow that positions the valve actuator. The dual servovalves provide redundancy that permits one servovalve to fail and still produce no change in actuator performance. A fail-operate servoswitch is used to automatically select the redundant servovalve upon failure of a single servovalve. If both servovalves fail, a fail-safe servoswitch hydraulically locks the servoactuator.

All actuators, except for the chamber coolant valve, have an emergency shutdown system to pneumatically close the propellant valves. Sequence valves in the oxidizer preburner oxidizer valve, the fuel preburner oxidizer valve, and the chamber coolant valve actuators close the five propellant valves in proper order during a pneumatic shutdown.

CONTROLLER

The checkout, start, in-flight operation, and shutdown of the Space Shuttle Main Engines are managed by dual redundant 16-bit digital computers and their input and output electronics. This electronics package is called a controller (fig. 2-6) and is mounted on the engine.

The controller interfaces with the hydraulic actuators and their position feedback mechanisms, spark igniters, solenoids, and sensors to provide closed-loop control of the thrust and propellant mixture ratio, while monitoring the performance of critical components on the engine and providing the necessary redundancy management to ensure the highest probability of proper and continued engine performance. These monitoring and control tasks are repeated every 20 milliseconds (50 times per second). Critical engine operation parameters (temperature, pressure, and speed) are monitored for exceeding predetermined values, which indicates impending engine malfunction. Exceeding any of these parameters will result in the controller performing a safe engine shutdown. Status information is reported to the vehicle for proper action and postflight evaluation.

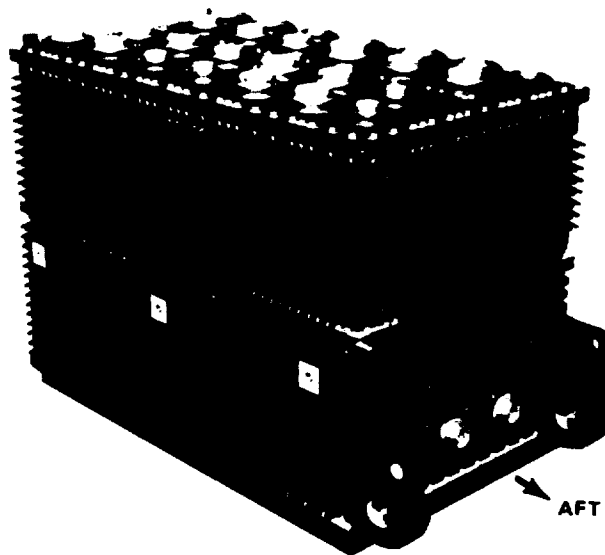

- COMPUTER CONTROL OF ENGINE
- WEIGHT
97 kg (213 LB)
- SIZE
36.8 BY 46.4 BY 59.7 cm (14.5 BY 18.25 BY 23.5 IN.)

Figure 2-6.—SSME controller assembly.

The controller receives commands from the vehicle's guidance and navigation computers for the checkout, start, thrust-level requirements (throttling), and shutdown. The controller, in turn, performs the necessary functions to start, change from one thrust level to another within 1-percent accuracy, and shut down as defined by the commands from the vehicle.

In addition to controlling the engine, the controller performs self-tests and switches to the backup computer channel and its associated electronics in the event of a failure. Similar tests are performed on the components interfacing with the controller and the necessary actions are taken to remove faulty components from the active control loop. One failure in any of the electronic components can be tolerated and normal engine operation will continue. Some second failures can be tolerated if the only result is degraded performance of the engine; however, in all cases, the controller will effect an engine shutdown when all methods for engine electrical monitoring and control are exhausted.

The controller is packaged in a sealed, pressurized chassis, with cooling provided by convection heat transfer (transfer of heat from its source to that of a lower temperature) through pin fins as part of the main chassis.

Controller Functional Organization

The controller is functionally divided into five subsystems: input electronics, output electronics, computer interface electronics, digital computer, and power supply electronics. Each of the five subsystems is duplicated to provide dual redundant capability.

The input electronics subsystem receives data from the engine sensors, conditions the signals, and converts them to digital form for computer use. The sensors for engine control and critical parameter monitoring (redlines) are dual redundant. The sensors for data only are nonredundant.

The output electronics subsystem converts the computer digital control commands into voltages suitable for powering the engine spark igniters, the solenoids, and the propellant valve actuators.

The computer interface electronics subsystem controls the flow of data within the controller, the input data to the computer, and the computer output commands to the output electronics. It also provides the controller interface with the vehicle for receiving engine commands (triple redundant channels) from the vehicle and for transmission of engine status and data (dual redundant channels) to the vehicle.

The digital computer subsystem is an internally stored general-purpose digital computer that provides the computational capability necessary for all engine control and monitoring functions. The computer memory has a program storage capacity of 16 384 words. Typical computer instruction times are 2 microseconds to add and 9 microseconds to multiply.

The power supply electronics subsystem converts the 115-volt, three-phase, 400-hertz vehicle power to the individual voltages required to operate the computers, input and output electronics, computer interface electronics, and other engine electrical components.

Controller Software

The software is an online, real-time, process control program. The program will process inputs from engine sensors; control the operation of actuators, solenoids, and spark igniters; accept and process vehicle commands; provide and transmit data to the vehicle; and provide test/checkout and monitoring capabilities.

2. SPACE TRANSPORT SYSTEM PROPULSION

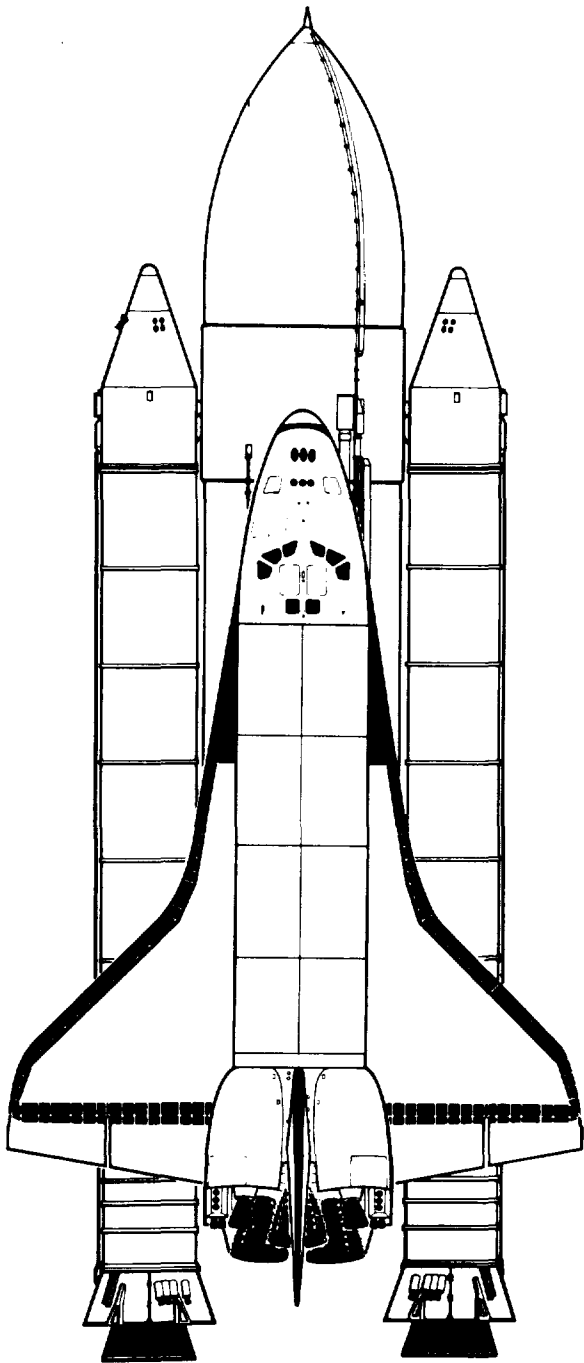

Solid Rocket Boosters

SOLID ROCKET MOTOR.....	2-19
Motor Case.....	2-19
Insulation and Liner.....	2-20
Propellant.....	2-20
Ignition System.....	2-21
Nozzle.....	2-22
Refurbishment.....	2-23
STRUCTURES.....	2-23
Forward Assembly.....	2-23
Aft Skirt.....	2-24
SRB/ET Attach Points and Separation.....	2-24
Systems Tunnel.....	2-25
THRUST VECTOR CONTROL.....	2-25
PARACHUTE RECOVERY SYSTEM.....	2-27
ELECTRICAL SYSTEM AND INSTRUMENTATION.....	2-29
ORDNANCE.....	2-30
BOOSTER SEPARATION MOTORS.....	2-30
THERMAL PROTECTION SYSTEM.....	2-31

Briefly...

The Solid Rocket Boosters operate in parallel with the main engines for the first 2 minutes of flight to provide the additional thrust needed for the Orbiter to escape the gravitational pull of the Earth. At an altitude of approximately 45 kilometers (24 nautical miles), the SRB's separate from the Orbiter/External Tank, descend on parachutes, and land in the Atlantic Ocean. They are recovered by ships, returned to land, and refurbished for reuse.

STATISTICS FOR EACH BOOSTER

THRUST AT LIFT-OFF

11 790 kilonewtons (2 650 000 pounds)

PROPELLANT

Atomized aluminum powder
(fuel), 16 percent

Ammonium perchlorate
(oxidizer), 69.83 percent

Iron oxide powder
(catalyst), 0.17 percent (varies)

Polybutadiene acrylic acid
acrylonitrile (binder), 12 percent

Epoxy curing agent, 2 percent

WEIGHT

Empty: 87 550 kilograms
(193 000 pounds)

Propellant: 502 125 kilograms
(1 107 000 pounds)

Gross: 589 670 kilograms
(1 300 000 pounds)

THRUST OF BOTH BOOSTERS

AT LIFT-OFF

23 575 kilonewtons (5 300 000 pounds)

GROSS WEIGHT OF BOTH BOOSTERS

AT LIFT-OFF

1 179 340 kilograms (2 600 000 pounds)

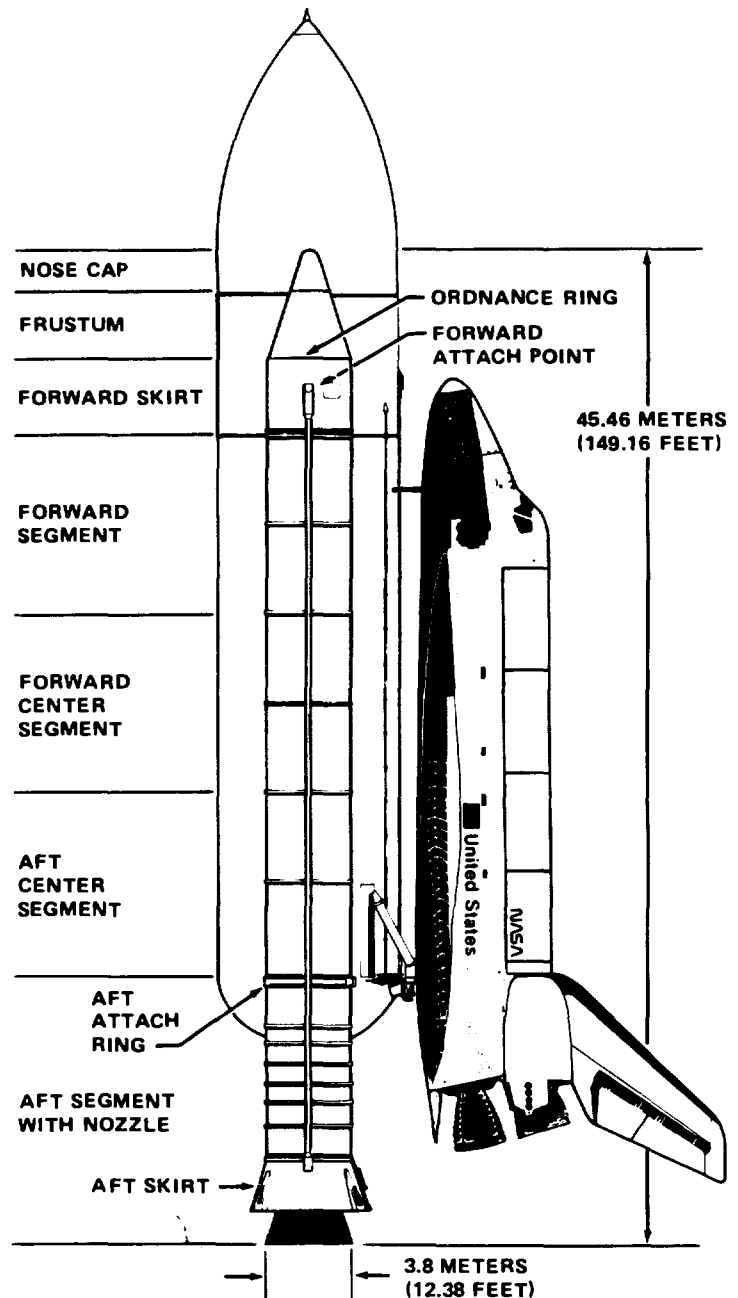

Solid Rocket Boosters

Two Solid Rocket Boosters (SRB's) operate in parallel to augment the thrust of the Space Shuttle Main Engines (SSME's) from the launch pad through the first 2 minutes of powered flight. The boosters also assist in guiding the entire vehicle during the initial ascent; following separation (fig. 2-7), they are recovered, refurbished, and reused. Each SRB contains several subsystems in addition to its basic component, the solid rocket motor (SRM). These are the structural, thrust vector control, separation, recovery, and electrical and instrumentation subsystems.

SOLID ROCKET MOTOR

The heart of the booster is the solid rocket motor (fig. 2-8). It is the largest solid propellant motor ever developed for space flight and the first built

to be used on a manned craft. Larger solid motors have been test-fired but have never been carried through complete development to the flight cycle. The huge solid rocket motor is composed of a segmented motor case loaded with solid propellants, an ignition system, a movable nozzle, and the necessary instrumentation and integration hardware.

Motor Case

Each motor case is made of 11 individual weld-free steel segments. Averaging approximately 1.27 centimeters (0.5 inch) thick, the steel is high strength. Each segment is heat-treated, hardened, and machined to the exact dimensions required. The 11 segments are held together by 177 high-strength steel pins at each case segment joint. The clevis-type joints are wrapped with reinforced fiberglass tape and sealed with a rubber seal band that is bonded to the case with adhesives.

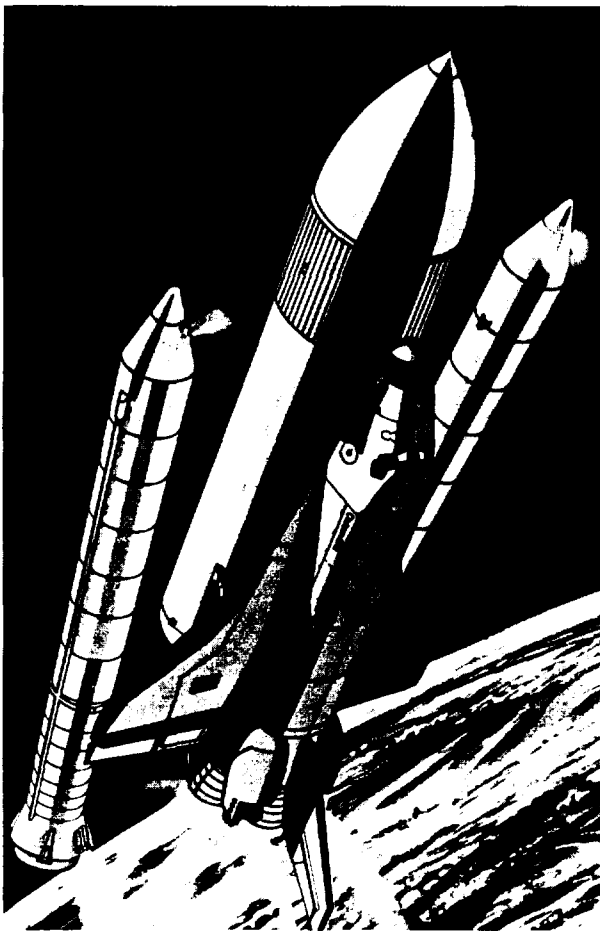

Figure 2-7.—Separation of Space Shuttle Solid Rocket Boosters (MSFC 003382).

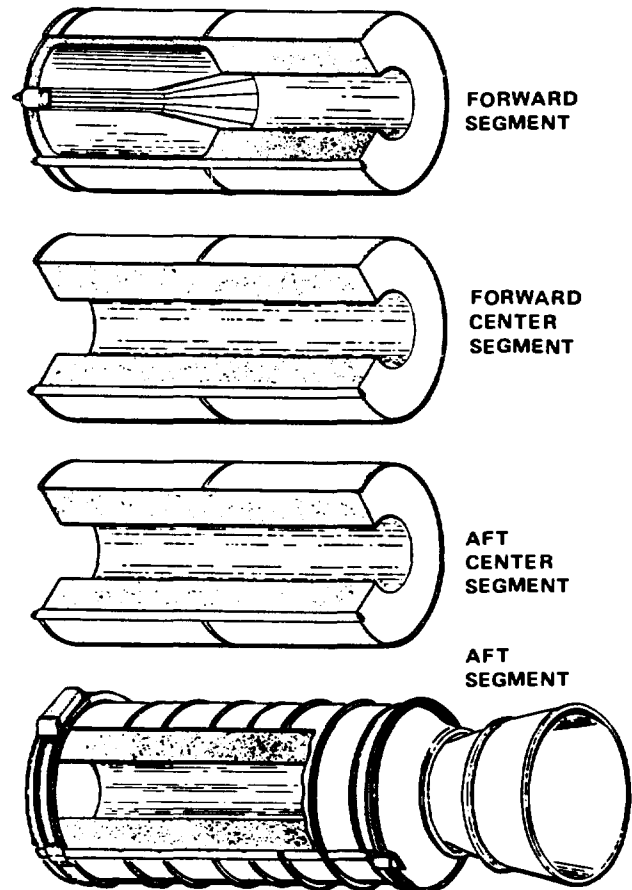

Figure 2-8.—Space Shuttle solid rocket motor.

The 11 segments are the forward dome segment, six cylindrical segments, the aft External Tank (ET) attach ring segment, two stiffener segments, and the aft dome segment. From the 11 segments, four subassemblies or "casting segments" are preassembled before loading the propellants. These four subassemblies are the forward casting segment, two center casting segments, and the aft casting segment. The assembled case has an overall length of 35.3 meters (115.7 feet) and a diameter of 3.7 meters (12.2 feet).

Insulation and Liner

Insulation inside the motor case is designed to protect the case so it can be used 20 times. The propellant inside the motor burns at a temperature of 3475 K (3204° C or 5800° F) for about 2 minutes. Approximately 11.3 metric tons (12.5 tons) of insulation are applied inside the motor. The thickness of the insulation varies from 0.25 to 12.7 centimeters (0.1 to 5.0 inches), depending on the time of exposure to the hot gases. Most of the insulation consists of a material called nitrile butadiene rubber (NBR), which has been used in previous rocket motors. The insulation is applied in sheets that stick together and that are laid down in such a way that the insulation adheres to an adhesive that has been applied to the inside of the case walls. The insulated casting segment is placed in an autoclave (similar to a pressure cooker) to cure the insulation by vulcanization at a temperature of 422 K (149° C or 300° F) for 2 to 2.5 hours. After cooling, the insulation becomes a solid material firmly bonded to the case wall. In the dome of the aft segment, carbon fiber-filled ethylene propylene diene monomer (EPDM) is applied over the NBR. The final step in protecting the motor case from the extreme temperatures is to spray a thick liner material over the insulation to form a bond between it and the propellant. The liner material, an asbestos-filled carboxyl terminated polybutadiene (CTPB) polymer, is compatible with the insulation and propellant. After curing for 44 hours at 330 K (57° C or 135° F), the lined casting segments are placed vertically into casting pits that are 6 meters (20 feet) square and 12 meters (40 feet) deep.

Propellant

The propellant used in the motor has been thoroughly proved in previous programs. It has excellent safety characteristics that have been

demonstrated by standard Department of Defense hazard classification tests. The propellant type is known as PBAN, which means polybutadiene acrylic acid acrylonitrile terpolymer. In addition to the PBAN, which serves as a binder, the propellant consists of approximately 70-percent ammonium perchlorate (the oxidizing agent), 16-percent powdered aluminum (a fuel), and a trace of iron oxide to control the burning rate.

Cured propellant looks and feels like a hard rubber typewriter eraser. The combined polymer binder and its curing agent is a synthetic rubber. Flexibility of the propellant is controlled by the ratio of binder to curing agent and the solid ingredients, namely oxidizer and aluminum.

Each solid rocket motor contains more than 450 000 kilograms (1 million pounds) of propellant, which requires an extensive mixing and casting operation at the plant site in Utah. The propellant is mixed in 2271-liter (600-gallon) bowls (fig. 2-9) located in three different mixer buildings. The propellant is then taken to special casting buildings and poured into the casting segments. A core mandrel is positioned in the casting segment prior to the casting operation.



Figure 2-9.—Space Shuttle SRB propellant (MSFC 885388).

The propellant is poured under vacuum into the segments around the mandrels. After the pouring, the vacuum is released and a cover is placed over the casting pit. The segments are then cured for 4 days at a temperature of 330 K (57° C or 135° F). Following this, the mandrel is removed, creating the burning cavity of the motor.

The high thrust level during lift-off of the Shuttle results from an 11-point-star propellant configuration in the forward segment. After lift-off, thrust is reduced by the total burnout of the star points (at 62 seconds into the flight) to constrain flight dynamic pressure. Thrust then gradually increases because of the design of the burning cavity. When the flame surface of the burning propellant reaches the liner surface, the thrust again starts to decay and continues to decay until burnout (about 10 seconds later).

Ignition System

The ignition system (fig. 2-10) is located in the forward dome segment. The ignition sequence is fast-moving and begins when two devices known as NASA standard initiators (NSI's) are fired, igniting a booster charge of boron potassium nitrate ($BKNO_3$) pellets. The pellets start a small rocket motor, called a pyrogen igniter, which is a motor within a motor. The first motor is the igniter initiator. It is approximately 18 centimeters (7 inches) long and 13 centimeters (5 inches) in diameter. The second motor is the main igniter. It is approximately 91 centimeters (36 inches) long and 53 centimeters (21 inches) in diameter. The igniter motor flame reaches 3172 K (2899° C or 5250° F) to start SRM propellant burning. Once the SRM propellant begins to burn, flame-spreading occurs in approximately 0.15 second and the motor reaches full operating pressure in less than 0.5 second.

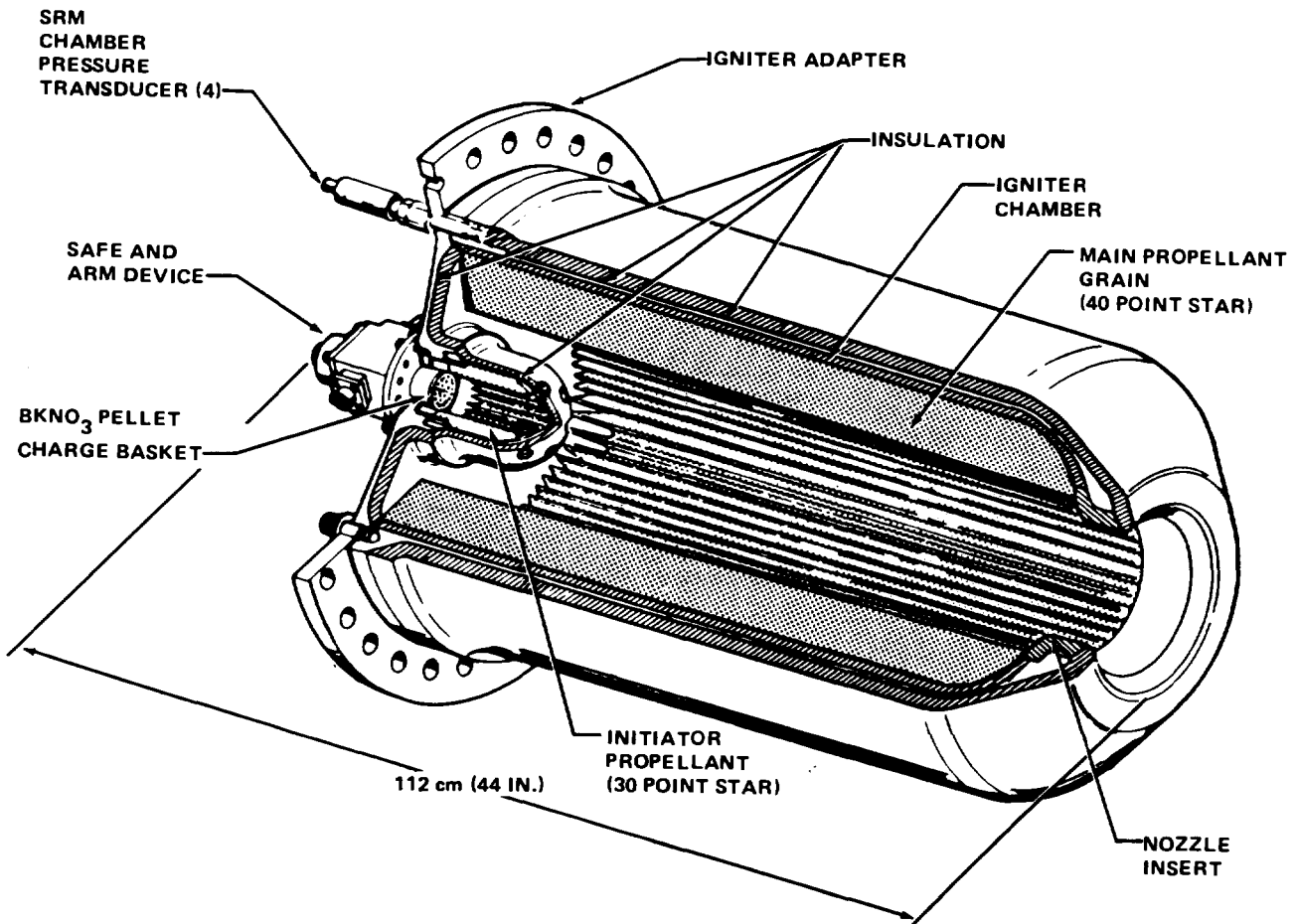

Figure 2-10.—Solid rocket motor igniter.

A built-in safety mechanism, the safe-and-arm device, prevents the propellant from igniting prematurely even if the NSI initiators are inadvertently fired. The entire ignition system, including the safe-and-arm device, is 112 centimeters (44 inches) long and weighs almost 318 kilograms (700 pounds), of which nearly 64 kilograms (140 pounds) is igniter propellant.

As the propellant burns, huge quantities of hot gases are formed and forced through the nozzle. The nozzle restricts the flow of these gases, providing the pressure and producing thrust. The gaseous products accelerate quickly as they expand past the narrow part of the nozzle, which causes the gases to speed up to approximately 9700 km/h (6000 mph) by the time they leave the exit cone.

Nozzle

The huge nozzle (fig. 2-11) is 4.19 meters (13.75 feet) long and weighs more than 9950 kilograms (22 000 pounds). The nozzle throat is 137 centimeters (54 inches) in diameter and the exit cone is 376 centimeters (148 inches) in diameter. To survive a temperature of 3474 K (3204° C or 5800° F) for 2 minutes, materials that restrict and ablate rather than absorb heat are used to make a liner that is attached to the metal shell of the nozzle.

A flexible bearing allows the nozzle to move, or gimbal, to control the direction of the rapidly moving gases. During the recovery sequence, a linear-shaped charge separates most of the nozzle exit cone, which is not recovered. This is done to prevent excessive loads in the boosters at the time of water impact.

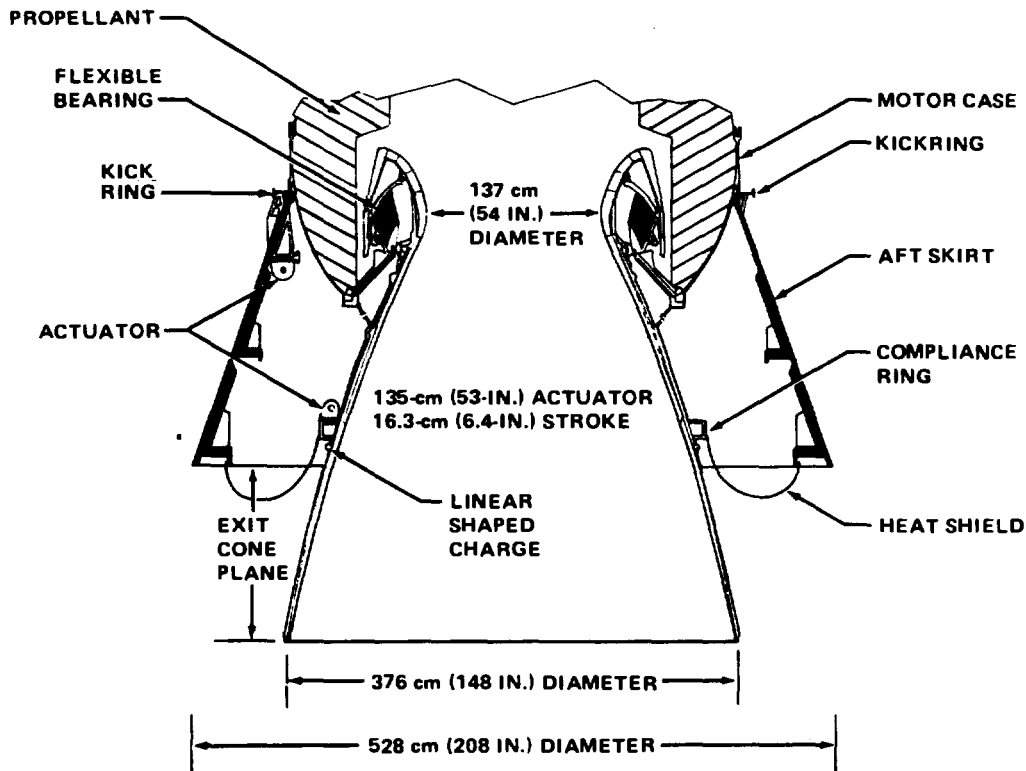

Figure 2-11.—Solid rocket motor nozzle.

Refurbishment

The used solid rocket motors are returned to the manufacturing plant the same way they were delivered; i.e., separated into four casting segments. The first stop for the segments after arrival at the plant is a washout facility where the insulation and any remaining propellant are washed out. To do this, the casting segment is positioned on a tilt table and raised to a 30° angle. Streams of water at pressures up to 41 370 kN/m² (6000 psi) are used to remove the propellant and insulation. The casting segments are then disassembled into the original 11 smaller case segments and sent through a degreasing and grit-blasting process. The segments then undergo magnetic particle inspection to determine whether any cracks or defects exist. Next, the case segments are filled with oil and hydroproof tested, during which the oil pressure is raised to 7612 kN/m² (1104 psig). A second magnetic inspection is performed to see if the hydroproof test resulted in any damage. The refurbished case segments are then reassembled into casting segments, repainted, and prepared again for flight.

STRUCTURES

The structural subsystem (fig. 2-12) provides structural support for the Shuttle vehicle on the launch pad; transfers thrust loads to the ET/Orbiter combination; and provides the housing, structural support, and bracketry needed for the recovery system, the electrical components, the separation motors, and the thrust vector control system.

Forward Assembly

The Solid Rocket Booster forward assembly consists of the nose cap, the frustum, the ordnance ring, and the forward skirt.

Nose cap.— The nose cap, bearing the aerodynamic load, is made of lightweight stiffened aluminum. The 145-kilogram (320-pound) cap is 190.5 centimeters (75 inches) in overall length and has a base diameter of 172.11 centimeters (67.76 inches). The nose cap houses the pilot and drogue parachutes.

Frustum.— The frustum is a truncated cone 320 centimeters (126 inches) long, 370.8 centimeters (146 inches) in diameter at the base (identical to the SRB diameter), and 172.11 centimeters (67.76 inches) at the top where it joins the nose cap. Mounted on top are six alignment pins, 10 centimeters (4 inches) long and 1.90 centimeters (0.75 inch) in diameter, to position the nose cap.

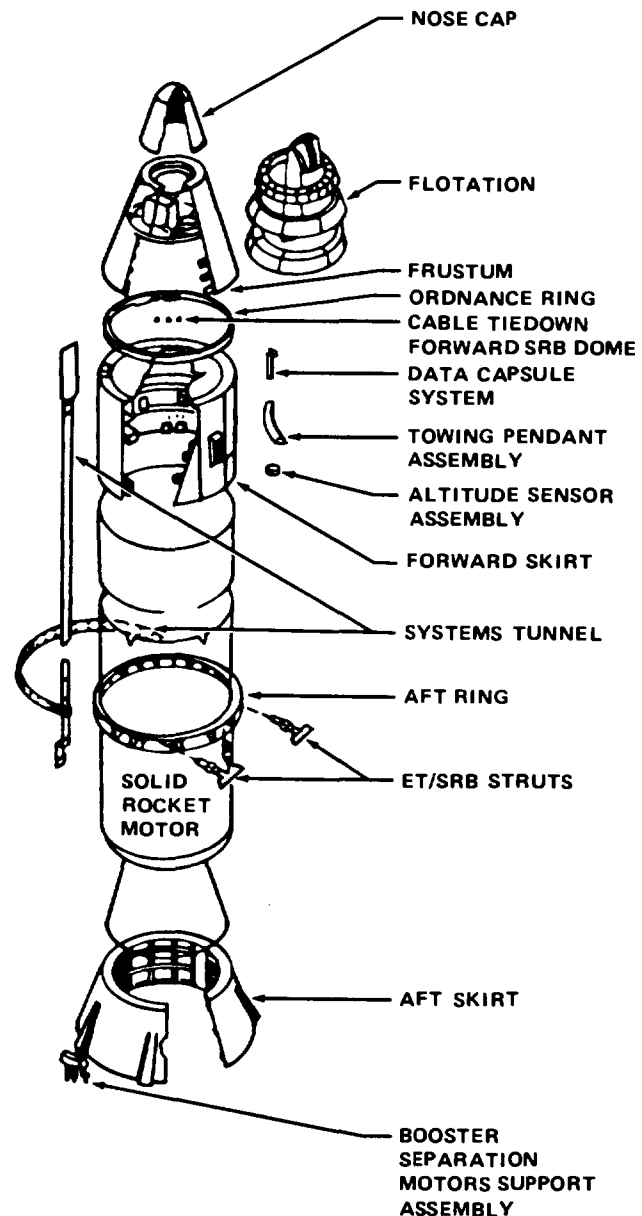

Figure 2-12.—SRB structural system (MSFC 776268A).

The 1606-kilogram (3540-pound) frustum houses the three main parachutes of the recovery system, the altitude switch and frustum location aids, and the flotation devices. The frustum also provides structural support for a cluster of four booster separation motors.

Ordnance ring.— The ordnance ring connects the frustum with the forward skirt and contains a linear-shaped pyrotechnic charge that cuts the frustum and forward skirt apart. The 145-kilogram (320-pound) ring is 15.2 centimeters (6 inches) wide and 5.1 centimeters (2 inches) thick with a diameter of 370.8 centimeters (146 inches).

Forward skirt.— The forward skirt is 317.5 centimeters (125 inches) long and 370.8 centimeters (146 inches) in diameter and weighs 2919 kilograms (6435 pounds). The structure is a welded cylinder of individual aluminum skin panels, varying in thickness from approximately 1.3 to 5 centimeters (0.5 to 2 inches), and contains a welded aluminum thrust post that absorbs axial thrust loads from the External Tank.

The forward skirt houses flight avionics, rate gyro assemblies, range safety system panels, and systems tunnel components. The structure also contains a towing pendant assembly that is deployed from a parachute riser after splashdown. A forward bulkhead seals the skirt from seawater intrusion and provides additional buoyancy.

Aft Skirt

The aft skirt is a truncated cone 229.9 centimeters (90.5 inches) long, 370.8 centimeters (146 inches) in diameter at the top (identical to the SRB diameter), and 538.5 centimeters (212 inches) at the base.

The skirt, which weighs 5443 kilograms (12 000 pounds), is manufactured of high-strength 1.3- to 5-centimeter (0.5- to 2-inch) thick aluminum stiffened with integrally machined aluminum longerons. The skin sections are rolled to the skirt's contour and welded together to provide the structural capability of supporting the entire 2 041 200-kilogram (4 500 000-pound) weight of the Space Shuttle on the mobile launch platform until launch, and of absorbing and transferring side loads during SRM nozzle gimbaling during

flight. The SRM nozzle gimbals a nominal 4.7° in all directions and up to 6.65° under certain conditions.

The aft skirt provides mounting provisions for the thrust vector control system and provides structural support for the aft cluster of four booster separation motors.

The weight of the entire Space Shuttle is borne by holddown post assemblies that provide rigid physical links between the mobile launch platform and the two aft skirts. The uppermost components of the holddown post assemblies are four forged aluminum posts welded to the skirt's exterior. Each post has a rectangular base 50.8 by 30.5 centimeters (20 by 12 inches) and tapers into the contour of the aft skirt. Each is designed to withstand compression loads in a 344 700- to 413 700- kN/m² (50 000- to 60 000-psi) range to support 255 150 kilograms (562 500 pounds), or one-eighth of the weight of the flight-ready Space Shuttle. The posts rest on aft skirt shoes, which provide the interface between the post and the launch platform.

At lift-off, an electrical signal is sent to 16 detonators, 2 in each of the 8 frangible nuts holding the Solid Rocket Boosters to the launch pedestal. The detonation cracks open the nuts, releasing their grip on the holddown posts and permitting lift-off.

SRB/ET Attach Points and Separation

The External Tank is attached to each Solid Rocket Booster in two locations: the thrust post of the forward skirt at the forward end and three aft attach struts mounted to the ET attach ring at the aft end.

A single pyrotechnic separation bolt joins the thrust post of the forward skirt and the ET attach fitting. The bolt, 66.98 centimeters (26.37 inches) long and 8.76 centimeters (3.45 inches) in shank diameter, is made of high-grade steel (similar in composition and design to the separation bolt of the Viking Mars orbiter/lander). It is designed to carry the 899-kilonewton (202 000-pound) tension load that occurs after SRM thrust has decayed to zero.

The three aft attach struts are designed to react to lateral loads induced by SRB/ET movements, both on the mobile launch platform because of cryogenic loading and after lift-off because of dynamic loads associated with ascent. The struts also provide the separation joint for SRB/ET separation. Each strut is 90.8 centimeters (35.75 inches) long and 19 centimeters (7.5 inches) in diameter and is made of a high-strength corrosion-resistant steel alloy designed to carry a maximum 1753-kilonewton (394 000-pound) tension or compression load.

Embedded in each strut is a single pyrotechnic bolt 29.85 centimeters (11.75 inches) long and 12.07 centimeters (4.75 inches) in shank diameter. The struts are attached to the Solid Rocket Booster and the External Tank by pin joints. Spherical bearings in each strut's clevis ends permit rotation to avoid bending loads. (A clevis end is a U-shaped piece of metal with a bolt or pin passing through holes at both ends to allow rotation of the fastened components.)

The upper strut differs from the two lower struts in that an external flange is incorporated on each side of the separation plane to provide a mounting ring for pullaway connectors. One of the two lower struts is positioned diagonally for rotation stability.

The ET attach ring, located at the top of the aft motor casting segment, provides the structure on which the three aft attach struts are mounted.

At thrust tail-off, when pressure transducers sense a pressure drop, SRB separation from the ET is electrically initiated. The single forward separation bolt is broken when pressure cartridges force tandem pistons to function, causing the bolt housing to fail in tension. The same technique is used to break the separation bolts in the three aft attach struts.

Systems Tunnel

Each Solid Rocket Booster has a systems tunnel that provides protection and mechanical support for the cables associated with the electrical and instrumentation subsystem and the linear-shaped explosive charge of the range safety system. The tunnel extends along almost the entire length of the booster.

The 457-kilogram (1008-pound) tunnel is approximately 41 meters (133 feet) long, 25 centimeters (10 inches) wide, and 13 centimeters (5 inches) thick. It is constructed of an aluminum alloy slightly thicker than a filing cabinet wall.

THRUST VECTOR CONTROL

The thrust vector control (TVC) system, located in the aft skirt, is the assembly that gimbals the SRM nozzle and thus helps to steer the entire Shuttle vehicle. Rate gyros continuously measure the rate of SRB attitude deviation, and the Orbiter computer signals the TVC electromechanical servoactuators to impart to the nozzle the force to create yaw, pitch, and roll vehicle movements. The normal gimbal range is 4.7° in all directions and up to a maximum of 6.65°.

The thrust vector control system in each Solid Rocket Booster is composed of two power modules or hydraulic power units (HPU's) and two servoactuators. Each power unit normally provides the power to drive a single actuator; however, both units are interconnected to both actuators, enabling either to drive both actuators (at a slightly reduced response rate). Each hydraulic power unit has an auxiliary power unit (APU) (similar to a motor but fueled by liquid hydrazine), a fuel supply module, a fuel isolation valve, a hydraulic fluid reservoir, a hydraulic pump, and a hydraulic manifold.

A servoactuator is the heart of the self-adjusting mechanism that continually compares desired performance with actual performance and makes the necessary corrections. The TVC servoactuators extend or retract a dual-action piston in response to hydraulic pressure. The pistons' extended rods exert mechanical pressure on the nozzle, causing it to gimbal around a pivot. For identification purposes, one actuator in each TVC system is designated "rock" and the other "tilt." The joint action produces yaw, pitch, and roll movements in the booster and thereby attitude control in all directions. Each actuator measures approximately 135 centimeters (53 inches) in length and has a 16.3-centimeter (6.4-inch) stroke. In operation, the stroke is considerably shorter and is capable of making minute SRB attitude corrections.

Early in the countdown, the hydraulic power units are leak-tested with helium and pressurized with gaseous nitrogen, and the fuel supply module is loaded with liquid hydrazine. At T - 20 seconds, signals originating in the launch processing system are sent to the TVC system through a multiplexer-demultiplexer in the SRB aft integrated electronics assembly (IEA). Thereafter, the TVC system is on internal command.

The fuel flows over the APU catalyst bed, decomposes, and becomes a gas that drives the turbine. The turbine is linked to both the fuel pump and the hydraulic pump by a fixed-ratio gearbox. As the turbine speed increases, the fuel pump pressure output rises. An electronic control assembly monitors and controls the fuel flow, closing and reopening valves to maintain a nominal turbine speed of 72 000 rpm. The variable-delivery hydraulic pump, driven through the gearbox at a nominal 3600 rpm, provides hydraulic fluid from the hydraulic reservoir to the manifold, which collects and distributes the fluid to the servoactuators.

A heat shield (thermal curtain) insulates the TVC system and its servoactuators from high heat rates due to radiated heat from gases escaping from the SRM nozzle and the Orbiter's liquid engines. Not only must the TVC components be protected during flight and preserved for subsequent reuse, but the liquid hydrazine stored in the TVC system must also be kept cool enough to prevent autoignition. (Liquid hydrazine can burn above 394 K (121° C or 250° F).)

The nozzle gimbaling requires a heat shield that "gives" with the movements; therefore, it is not a rigid structure but a flexible "curtain" (similar to those used on other launch vehicles). It is attached inboard to the SRM nozzle's compliance ring and outboard to the aft ring of the aft skirt.

PARACHUTE RECOVERY SYSTEM

After separation, the Solid Rocket Boosters coast upward then fall toward Earth in a ballistic trajectory for almost 4 minutes (fig. 2-13). The boosters attain a maximum speed of approximately 4650 km/h (2890 mph) during the trajectory before being slowed by atmospheric drag.

The parachutes of the recovery system have canopies of concentric nylon ribbons, spaced like a venetian blind. The ribbon construction adds tensile strength for high-velocity deployment.

The pilot parachute, stored in the nose cap (fig. 2-14), is 3.5 meters (11.5 feet) in diameter and is designed for a maximum load of 6584 kilograms (14 515 pounds) during drogue parachute deployment. To begin deployment at an altitude of 4694 meters (15 400 feet), a barometric switch actuates three thrusters on the frustum that eject the nose cap. As the nose cap moves away from the vehicle, the pilot parachute is deployed. As soon as the pilot parachute inflates, cutters release the drogue parachute pack.

The drogue parachute, 16.5 meters (54 feet) in diameter and designed to sustain a maximum load of 122 470 kilograms (270 000 pounds), initially

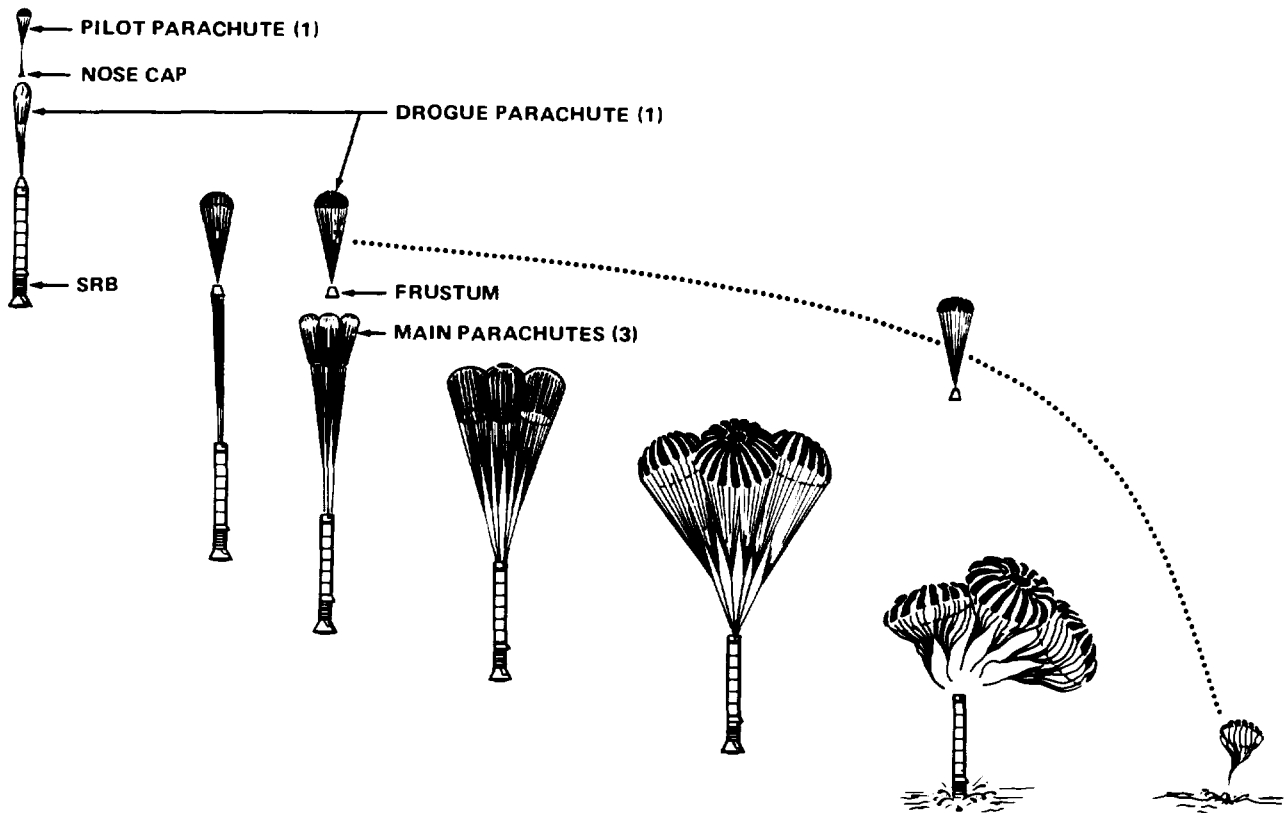

Figure 2-13.—SRB parachute deployment.

inflates approximately 60 percent. A reefing line is then cut to allow 80 percent inflation. At 2835 meters (9300 feet) altitude, a second reefing line is cut to allow full canopy inflation.

A second signal from the barometric switch activates an ordnance train at 2012 meters (6600 feet) altitude, detonating a 360° shaped charge around the ordnance ring and separating the frustum from the booster. The three main parachutes then deploy out of the base of the frustum and the frustum continues its descent attached to the drogue parachute.

The three main parachutes, each 35 meters (115 feet) in canopy diameter and with a combined

loading capacity of 242 200 kilograms (534 000 pounds), begin lowering the SRB on 52-meter (172-foot) lines at an initial descent rate of 376 km/h (233 mph). The main canopies undergo a double disreefing. When fully inflated at 670 meters (2200 feet) altitude, the main parachutes decelerate the vehicle to 111 km/h (69 mph). Atmospheric pressure further slows the descent to a water impact of approximately 95 km/h (60 mph). Upon splashdown, an impact switch activates an ordnance train that causes segmented nuts to release and separate the main parachutes.

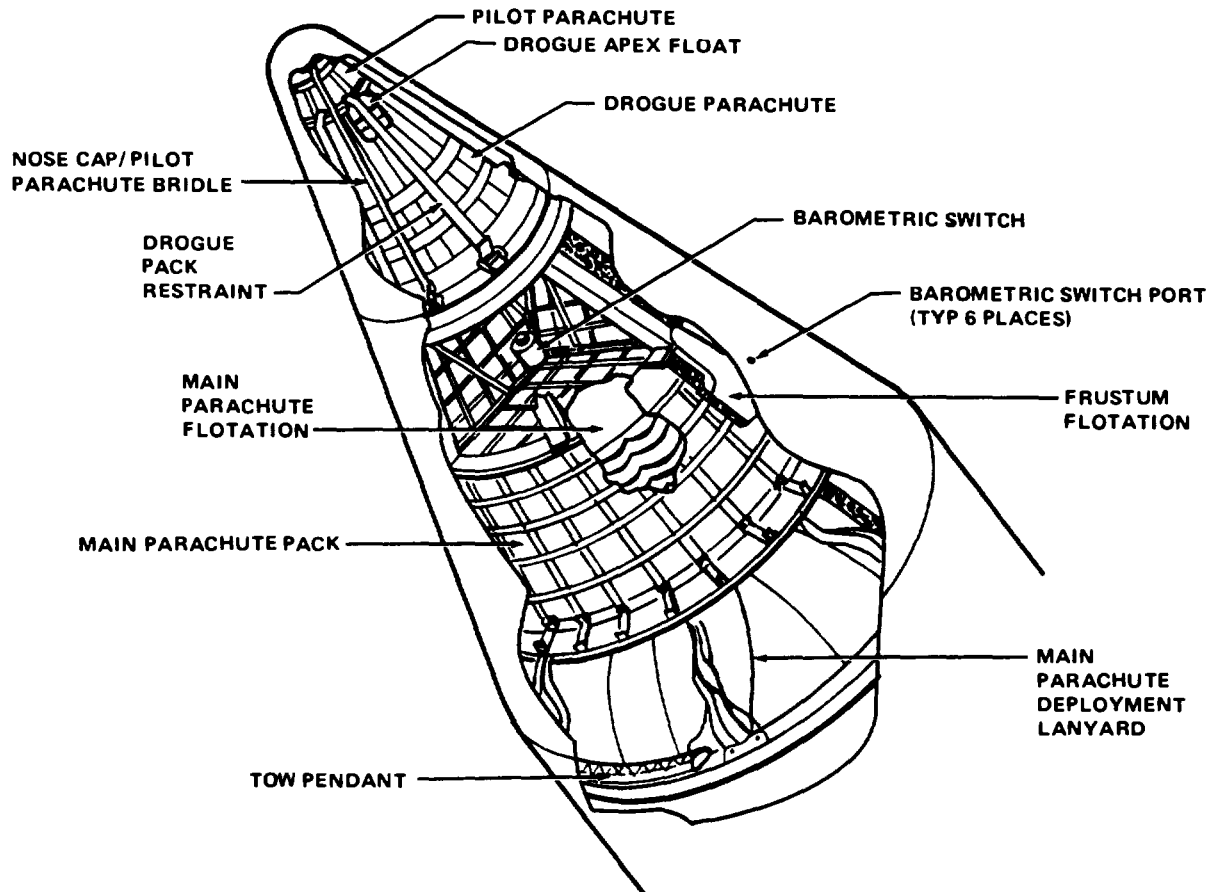

Figure 2-14.—SRB recovery system .

ELECTRICAL SYSTEM AND INSTRUMENTATION

The electrical system (fig. 2-15) distributes power to, from, and within the Solid Rocket Boosters for operation during ascent and descent and range safety. It uses two power sources, the Orbiter fuel cells and the SRB batteries. Range safety has an independent, redundant electrical circuitry activated during the final countdown hour and powered down at SRB/ET separation. Power from the fuel cells and from the recovery battery (one for each booster) is routed through two integrated electronics assemblies. During ascent, each Solid Rocket Booster is controlled by commands from the Orbiter processed through the electronics assemblies. This system also provides for data acquisition.

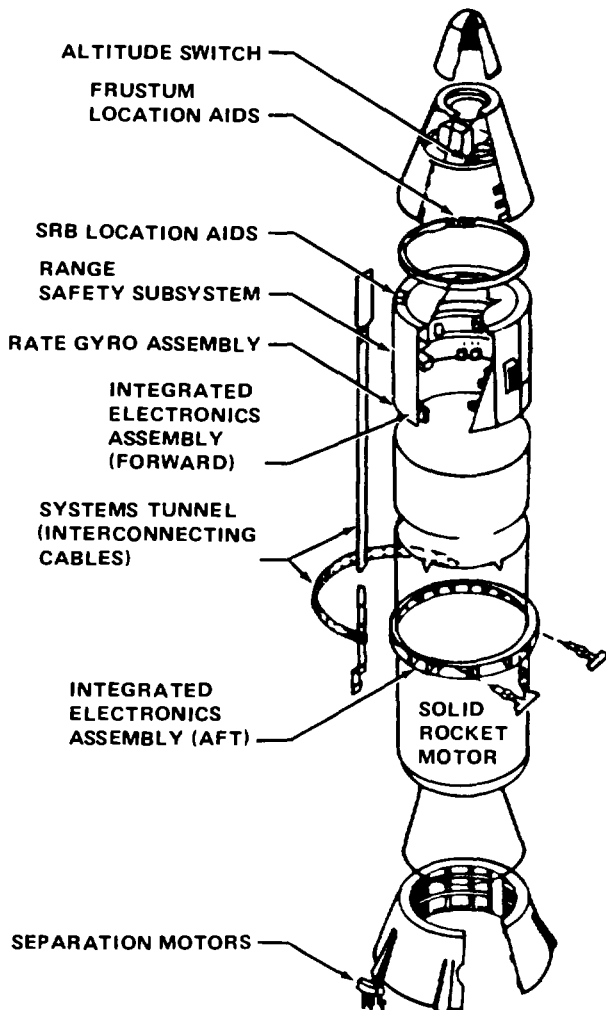

Figure 2-15.—SRB electrical system.

All commands are automatic and, for all critical functions, are routed by redundant solid-state components through redundant buses over redundant channels. In addition, the astronauts can initiate SRB/ET separation whether or not the automatic separation cue is received.

All information relating to mission safety—ignition of solid rocket motors, performance of the TVC system, and separation—is conveyed over redundant hard lines. All other commands and interrogations are routed through the two redundant multiplexer-demultiplexers of the integrated electronics assemblies. These devices receive and send coded messages over a single pair of wires and therefore save considerable weight.

The operational system includes the forward and aft electronics assemblies, rate gyro assemblies, SRB location aids, frustum location aids, the recovery battery, altitude switches, and some sensors. The IEA distributor contains the pyrotechnic initiator controllers that are essential for functional reliability of the pyrotechnics. These controllers are integrated logic circuits that are the Space Shuttle version of automotive spark plugs. Each pyrotechnic initiator controller is a capacitor energy storage and discharge device that requires three separate signals in proper sequence and timing to initiate an action.

Each Solid Rocket Booster has three rate gyro assemblies. An altitude switch assembly in the frustum initiates component separation at specific altitudes.

The SRB location aids consist of a radiofrequency beacon (radio transmitter) with a 17-kilometer (9-nautical-mile) range and a flashing white strobe light with a 9-kilometer (5-nautical-mile) range, pulsating at 500 watts intensity (similar in output to an aircraft beacon). The radio's 30.5-centimeter (12-inch) antenna and the strobe light are mounted on the apex of the dome of the forward skirt. These aids are actuated by the altitude switch and powered from the recovery battery.

The frustum location aids consist of a radiofrequency beacon and a strobe light of the same range, output, and configuration as the SRB location aids. These aids are powered by internal batteries and are activated by the closing of a "saltwater switch" in which saltwater acts as the conductor between two metal pins.

ORDNANCE

All major Solid Rocket Booster functions except steering—from launch pad release through SRB/ET separation to recovery of SRB segments—depend on electrically initiated pyrotechnics. The boosters use the following five types of explosive-actuated devices.

1. NASA standard initiator cartridges that contain compressed explosives
2. Frangible nuts with built-in weak points that break open from shock imparted by the cartridges
3. Thrusters with pressure-producing pyrotechnic charges that impart velocity to a released component to achieve distance
4. Separation bolts that incorporate tandem pistons exerting pressure on one another, causing the outer housing to stretch (fail in tension) and break at a weakened separation groove
5. Linear-shaped charges that compress explosive powder into rigid, chevron-shaped channels and, upon detonation, cut apart large structures by essentially the same technique as that used by the steel industry to cut bridge girders

All but the frangible nuts and separation bolts use so-called ordnance trains. Such a "train" consists of a NASA standard detonator (NSD) connected to a metal-sheathed fiberglass-wrapped fuse, called a confined detonating fuse, through a fuse manifold. The pencil-lead-thin fuse differs from industrial mild detonating fuses, such as those used in the mining industry, only by being "confined" in fiberglass. All SRB pyrotechnics are triggered by electrical signals from the pyrotechnic initiator controllers.

BOOSTER SEPARATION MOTORS

Small solid-fueled booster separation motors "translate" or move the Solid Rocket Boosters away from the Orbiter's still-thrusting main engines and External Tank. Four booster separation motors are clustered in each SRB's frustum; another cluster of four is mounted on each SRB's aft skirt. Both clusters are mounted on the SRB sides closest to the External Tank. The thrust of the clusters moves the SRB's away from the Orbiter.

Each of the 16 booster separation motors on the two Solid Rocket Boosters is 79 centimeters (31.1 inches) long and 32.64 centimeters (12.85 inches) in diameter and weighs 69 kilograms (152 pounds). Each has a specific impulse of 250 at vacuum and develops a nominal 97 860 newtons (22 000 pounds) of thrust. The nozzles of the booster separation motors are protected against autoignition from aerodynamic and radiated SSME plume heating. The aft clusters have 19-centimeter (7.5-inch) diameter aluminum nozzle covers. The ignition blast fractures the covers at predetermined notches and the exhaust plumes carry them away from the Orbiter/ET. The forward separation motor clusters, located within the frustum except for the protruding nozzles, are close enough to the Orbiter that blow-away covers might strike the vehicle. Therefore, these nozzle exits are protected by 19-centimeter (7.5-inch) diameter stainless steel covers that are merely blown open like doors when the booster separation motors are fired and thus remain attached to the motors. Detonators ignite the motors, which burn a nominal 0.66 second (maximum 1.05 seconds) to push the boosters away from the Orbiter/ET. At thrust termination, the distance vector between the noses of the SRB's and the Orbiter is a nominal 318 centimeters (125 inches).

THERMAL PROTECTION SYSTEM

The exterior surfaces of the Solid Rocket Booster, exposed to thermal heat loads, are insulated by ablative materials to withstand friction-induced heat.

Heating rates vary between SRB lift-off and SRB inert splashdown. Broadly, maximum temperatures of approximately 1533 K (1260° C or 2300° F) are encountered at the time of SRB/ET separation, when the boosters are

exposed to the plumes of the three Space Shuttle Main Engines. Maximum reentry temperatures are in the range of 578 to 589 K (304° to 315° C or 580° to 600° F). Splashdown temperatures are limited to 344 K (71° C or 160° F).

Various types of insulation, each with special characteristics, are used in thermally protecting the boosters. Cork and a sprayable ablative material are the primary insulating materials. Molded fiberglass is also used in the high-heat protuberance areas.

2. SPACE TRANSPORTATION SYSTEM PROPULSION

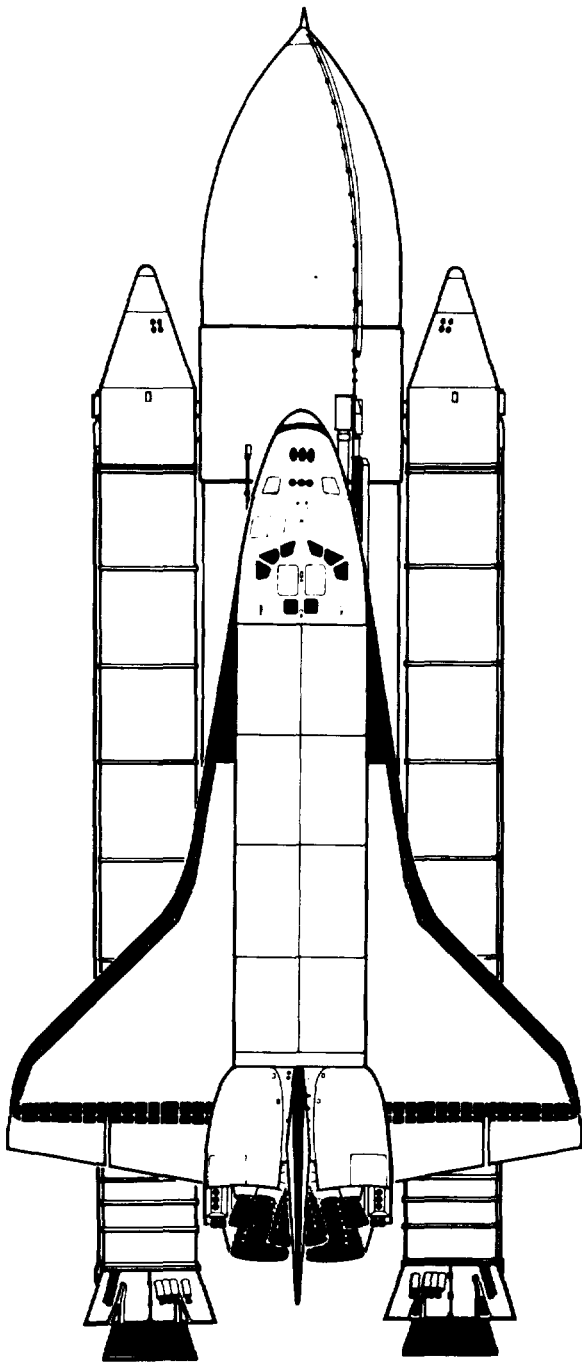

External Tank

STRUCTURES.....	2-35
Liquid Oxygen Tank	2-35
Liquid Hydrogen Tank.....	2-37
Intertank	2-38
PROPULSION SYSTEM	2-39
Liquid Oxygen Feed Subsystem	2-39
Liquid Hydrogen Feed Subsystem.....	2-40
Pressurization, Vent Relief, and Tumbling Subsystem	2-40
Environmental Conditioning	2-41
ELECTRICAL SYSTEM.....	2-41
Instrumentation	2-41
Cabling	2-41
Lightning Protection	2-41
THERMAL PROTECTION SYSTEM.....	2-41
INTERFACE HARDWARE	2-42
External Tank/Solid Rocket Booster Interfaces	2-42
External Tank/Orbiter Interfaces	2-42
External Tank/Facilities Interfaces.....	2-43

PRECEDING PAGE BLANK NOT FILMED

Briefly...

The External Tank is the "gas tank" for the Orbiter; it contains the propellants used by the main engines. Approximately 8.5 minutes into the flight with most of its propellant used, the ET is jettisoned and splashes down in the Indian Ocean. It is the only major part of the Space Shuttle system that is not reused.

TOTAL WEIGHT

Empty: 35 425 kilograms
(78 100 pounds)
Gross: 756 441 kilograms
(1 667 677 pounds)

PROPELLANT WEIGHT

Liquid oxygen: 616 493 kilograms
(1 359 142 pounds)
Liquid hydrogen: 102 618 kilograms
(226 237 pounds)
Total: 719 112 kilograms
(1 585 379 pounds)

PROPELLANT VOLUME

Liquid oxygen tank: 541 482 liters
(143 060 gallons)
Liquid hydrogen tank: 1 449 905 liters
(383 066 gallons)
Total: 1 991 387 liters
(526 126 gallons)

(Propellant densities of 1138 and 70.8 kg/m³
(71.07 and 4.42 lb/ft³) used for liquid oxygen
and liquid hydrogen, respectively)

DIMENSIONS

Liquid oxygen tank: 16.3 meters (53.5 feet)
Liquid hydrogen tank: 29.6 meters (97 feet)
Intertank: 6.9 meters (22.5 feet)

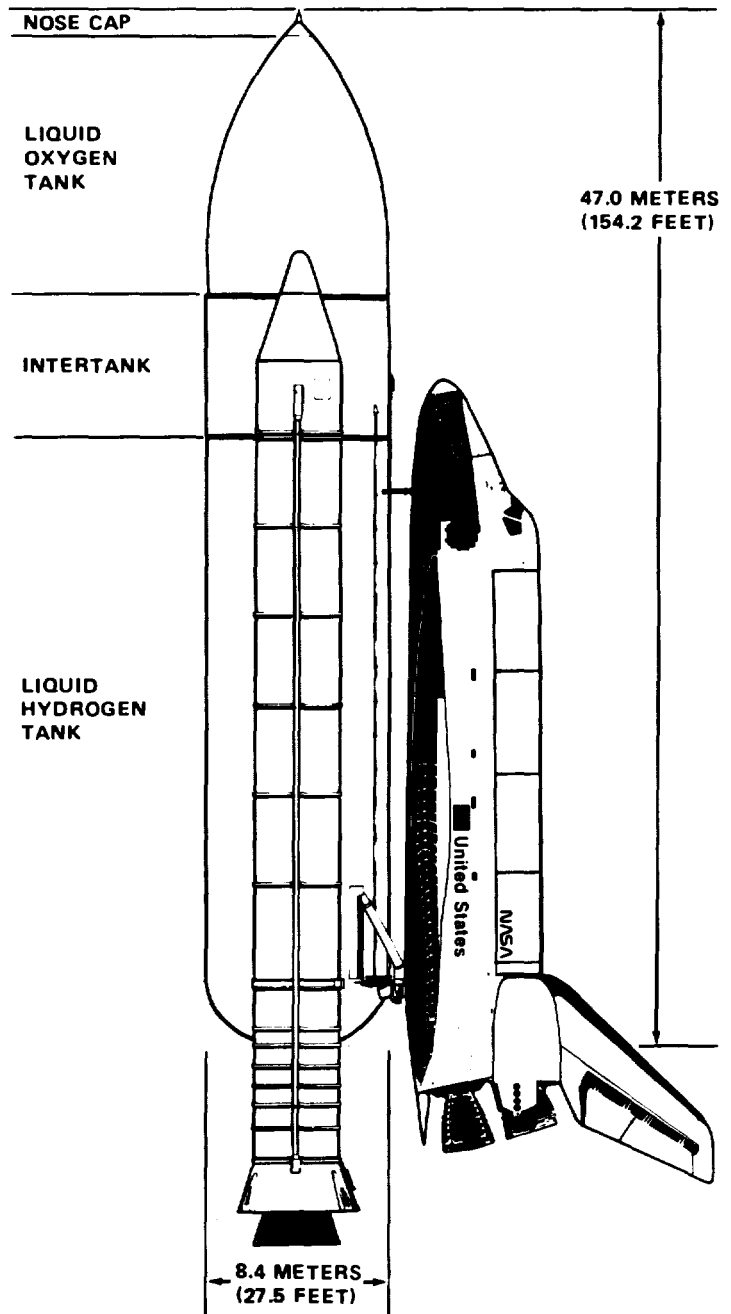

External Tank

The External Tank (ET) contains the propellants for the three Space Shuttle Main Engines (SSME's) and forms the structural backbone of the Shuttle system in the launch configuration. At lift-off, the External Tank absorbs the total 28 580-kilonewton (6 425 000-pound) thrust loads of the three main engines and the two solid rocket motors. When the Solid Rocket Boosters (SRB's) separate at an altitude of approximately 44 kilometers (27 miles), the Orbiter, with the main engines still burning, carries the External Tank piggyback to near orbital velocity, approximately 113 kilometers (70 miles) above the Earth. There, 8.5 minutes into the mission, the now nearly empty tank separates (fig. 2-16) and falls in a preplanned trajectory into the Indian Ocean. The External Tank is the only major expendable element of the Space Shuttle.

The three main components of the External Tank (fig. 2-17) are an oxygen tank, located in the forward position, an aft-positioned hydrogen tank, and a collar-like intertank, which connects the two propellant tanks, houses instrumentation and processing equipment, and provides the attachment structure for the forward end of the Solid Rocket Boosters.

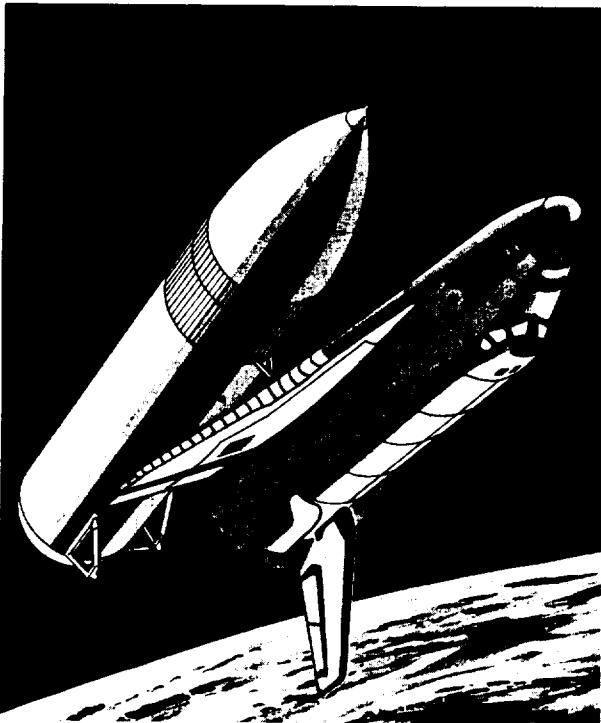

Figure 2-16.—Separation of Space Shuttle External Tank (MSFC 00308).

The hydrogen tank is 2.5 times larger than the oxygen tank but weighs only one-third as much when filled to capacity. The reason for the difference in weight is that liquid oxygen is 16 times heavier than liquid hydrogen.

The skin of the External Tank is covered with a thermal protection system that is a nominal 2.54-centimeter (1-inch) thick coating of spray-on polyisocyanurate foam. The purpose of the thermal protection system is to maintain the propellants at an acceptable temperature, to protect the skin surface from aerodynamic heat, and to minimize ice formation.

The External Tank includes a propellant feed system to duct the propellants to the Orbiter engines, a pressurization and vent system to regulate the tank pressure, an environmental conditioning system to regulate the temperature and render the atmosphere in the intertank area inert, and an electrical system to distribute power and instrumentation signals and provide lightning protection. Most of the fluid control components (except for the vent valves) are located in the Orbiter to minimize throwaway costs.

STRUCTURES

The tank structure is designed to accommodate complex load effects and pressures from the propellants as well as those from the two Solid Rocket Boosters and the Orbiter. Primarily constructed of aluminum alloys, the tank contains 917.6 meters (3010.5 linear feet) of weld. The basic structure is made of 2024, 2219, and 7075 aluminum alloys and the thickness ranges from 0.175 to 5.23 centimeters (0.069 to 2.06 inches).

Liquid Oxygen Tank

The liquid oxygen tank (fig. 2-18) contains 541 482 liters (143 060 gallons) of oxidizer at 90 K (-183°C or -297°F). It is 16.3 meters (53.5 feet) long and 8.4 meters (27.5 feet) in diameter. The weight, when empty, is 5695 kilograms (12 555 pounds); loaded, it weighs 622 188 kilograms (1 371 697 pounds).

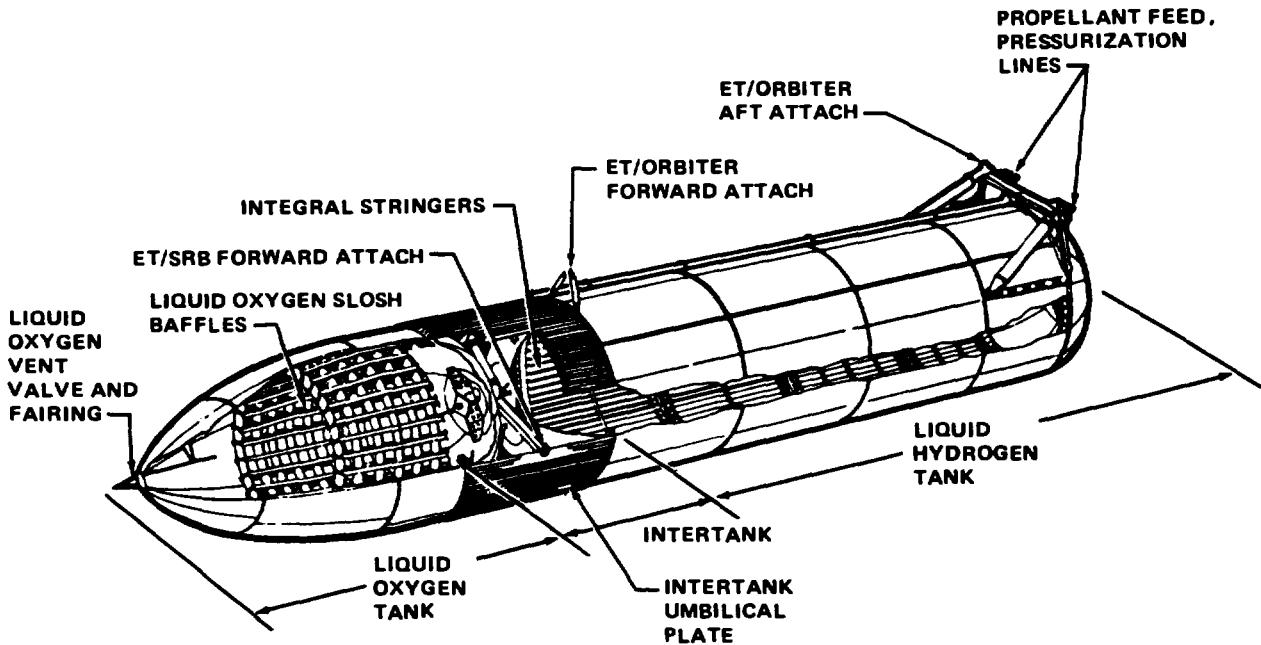

Figure 2-17.—Space Shuttle External Tank.

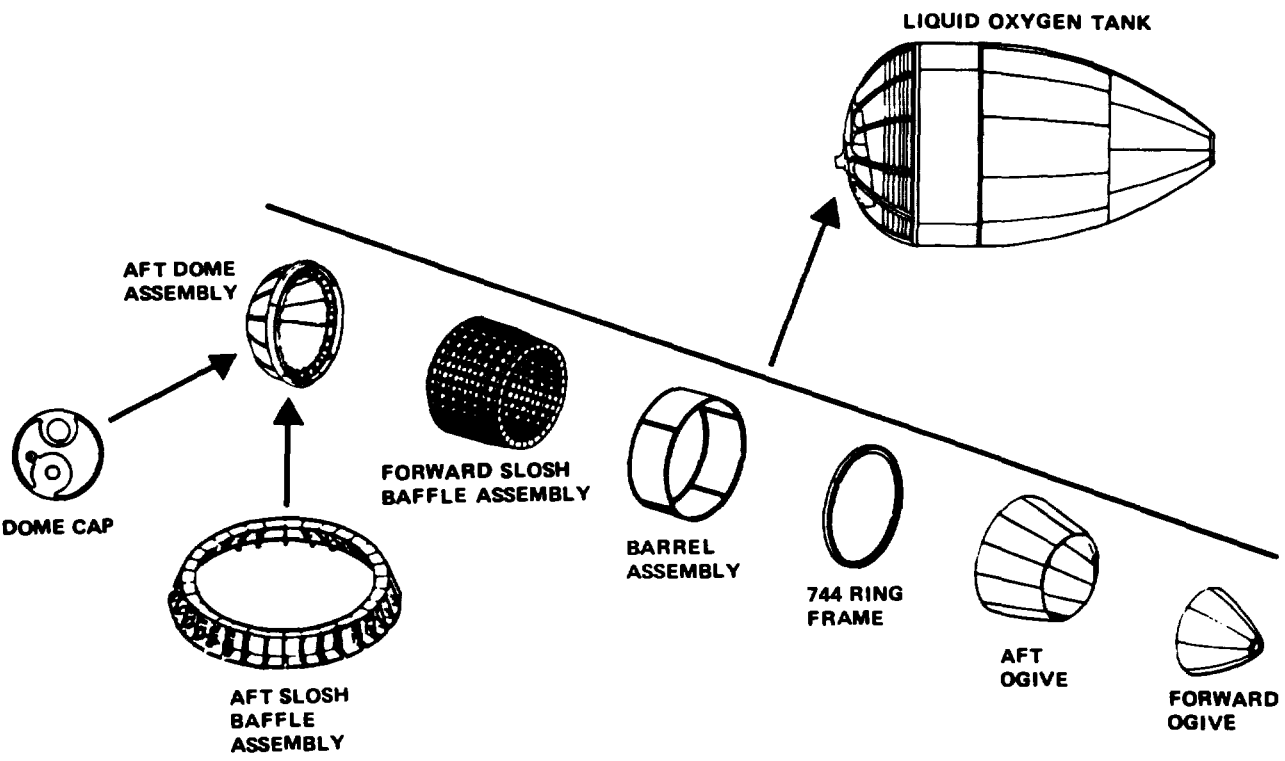

Figure 2-18.—ET liquid oxygen tank structural assembly.

The liquid oxygen tank is an assembly of preformed fusion-welded aluminum alloy segments that are machined or chemically milled. It is composed of gores, panels, machined fittings, and ring chords. Because the oxygen tank is the forwardmost component of the External Tank and also of the Space Shuttle vehicle, its nose section curves to an ogive, or pointed arch shape, to reduce aerodynamic drag. A short cylindrical section joins the ogive-shaped section to the aft ellipsoidal dome section. A ring frame at the juncture of the dome and cylindrical section contains an integral flange for joining the liquid oxygen tank to the intertank.

The major assemblies comprising the liquid oxygen tank are the nose cap and cover plate, the ogive nose section, the cylindrical barrel section, the slosh baffles, and the aft dome.

The conical nose cap that forms the tip of the liquid oxygen tank is removable and serves as an aerodynamic fairing for the propulsion and electrical system components. The cap contains a cast aluminum lightning rod that provides protection for the Shuttle launch vehicle. The cover plate serves as a removable pressure bulkhead and provides a mounting location for propulsion system components.

The ogive nose section is fusion-welded and consists of a forward ring, 8 forward gores, and 12 aft gores. It connects to the cylindrical barrel section, which is fabricated from four chemically milled panels.

Slosh baffles are installed horizontally in the liquid oxygen tank to prevent the sloshing of oxidizer. The baffles, which minimize liquid residuals and provide damping of fluid motion, consist of eight rings tied together with longitudinal stringers and tension straps. Slosh baffles are required only in the liquid oxygen tank because liquid oxygen, which is 12 percent heavier than water ($1\,137\text{ kg/m}^3$ (71 lb/ft^3)) compared to $1\,025\text{ kg/m}^3$ (64 lb/ft^3), could slosh and throw the vehicle out of control. The density of liquid hydrogen is low enough that baffles are not required.

Antivortex baffles are installed in both propellant tanks to prevent gas from entering the engines. Without them, the propellants would create a

vortex similar to a whirlpool in a bathtub drain. The baffles minimize the rotating action as the propellants flow out the bottom of the tanks. The slosh baffles form a circular cage assembly; the antivortex baffles look more like fan blades.

The dome section of the liquid oxygen tank consists of a ring frame, 12 identical gore segments, and a dome end cap 355.6 centimeters (140 inches) in diameter. The end cap contains a propellant feed outlet, an electrical connector, and a 91.4-centimeter (36-inch) manhole for access to the tank.

Liquid Hydrogen Tank

The liquid hydrogen tank (fig. 2-19) is the largest component of the External Tank. Its primary functions are to hold 1 449 905 liters (383 066 gallons) of liquid hydrogen at a temperature of 20 K (-253°C or -423°F) and to provide a mounting platform for the Orbiter and the Solid Rocket Boosters. The aluminum alloy structure is 29.9 meters (97 feet) long and 8.4 meters (27.5 feet) in diameter and is composed of a series of barrel sections, ellipsoidal domes, and ring frames. The weight, when empty, is 14 402 kilograms (31 750 pounds); loaded, it weighs 1 107 020 kilograms (257 987 pounds).

The liquid hydrogen tank is a fusion-welded assembly of four barrel sections, five main ring frames, and two domes. Thirteen intermediate ring frames stabilize the barrel skins and two longerons are installed in the aft barrel section to receive Orbiter thrust loads. The integrally stiffened skin of the tank is designed to be nonbuckling at limit load.

The forward and aft domes are welded assemblies of 12 gore segments, a dome cap, and a ring frame and are similar to the liquid oxygen tank dome. The two liquid hydrogen tank domes differ only in the provision for the mounting of fittings. The aft dome cap contains two manhole openings, one for general tank access and one for access to the liquid hydrogen antivortex baffle and screen. In addition, one gore segment contains a fitting for the liquid hydrogen feedline. The forward tank dome contains only one manhole opening for tank access. The manhole covers weigh 17 kilograms (37 pounds) each.

The cylindrical section consists of four barrel sections joined by three major ring frames using fusion butt welds. Each of the barrel sections is made from eight stiffened skin panels. The thickness of the skin panels used in both propellant tanks varies according to load requirements. The skin panels also include provisions for mounting support fittings for external propulsion system lines and for electrical conduits. Welded in the aft barrel section are two longeron sections and other structural fittings that distribute Orbiter and SRB loads.

Five major ring frames are used to join the dome and barrel sections, to receive and distribute loads, and to provide connections to the other structural elements.

Intertank

The intertank (fig. 2-20) is not a tank in itself but serves as a mechanical connection between the liquid oxygen and liquid hydrogen tanks. The primary functions of the intertank are to provide structural continuity to the propellant tanks, to serve as a protective compartment to house instruments, and to receive and distribute thrust loads from the Solid Rocket Boosters.

The intertank is a 6.9-meter (22.5-foot) long cylinder consisting of two machined thrust panels and six stringer stiffened panels. Unlike the propellant tanks, the intertank is constructed mechanically without weldments. On the launch pad, the intertank links a portion of the ET instrumentation to the ground through an umbilical panel.

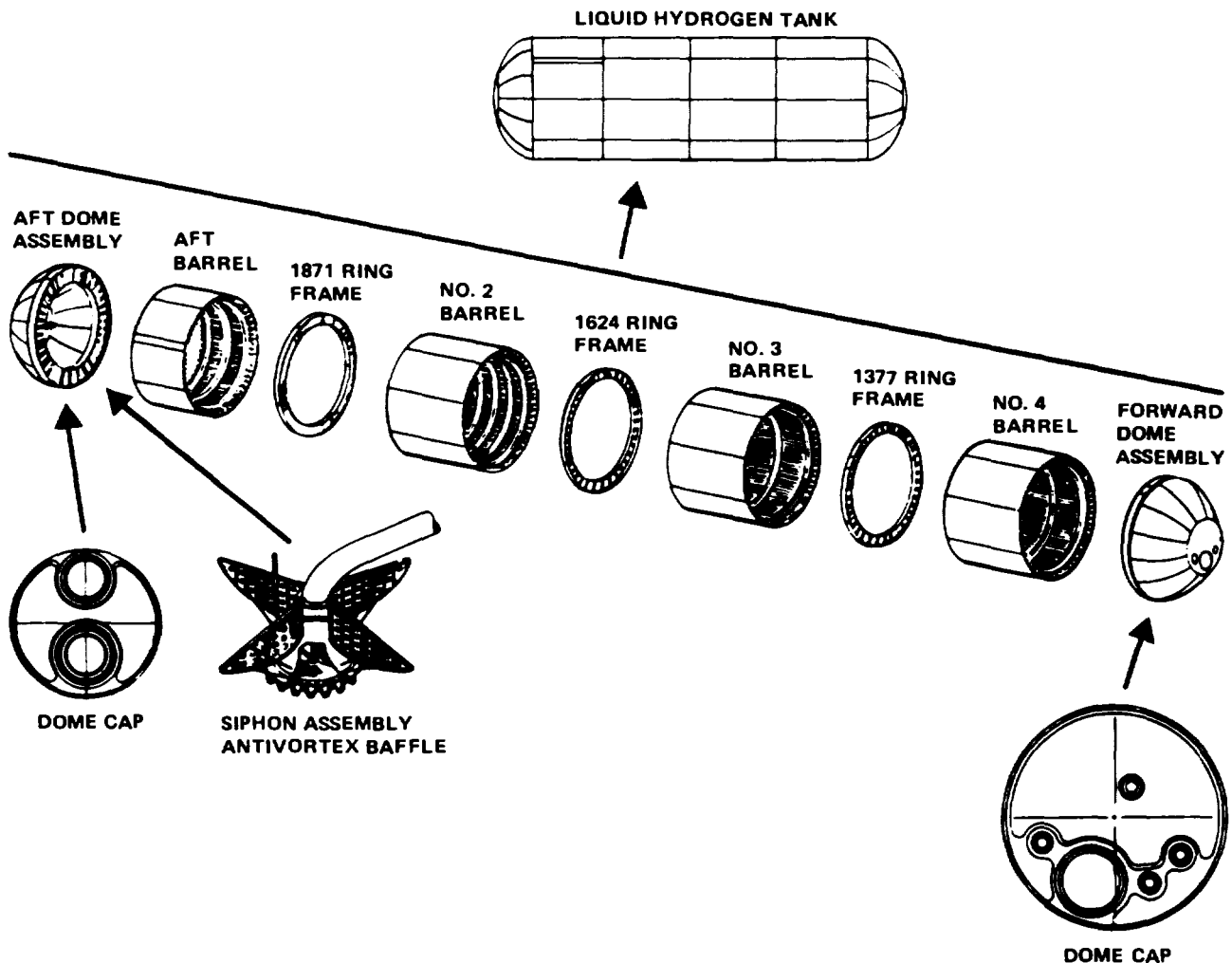

Figure 2-19.—ET liquid hydrogen tank structural assembly.

The use of the intertank also makes it possible for the External Tank to have separate propellant tank bulkheads (domes), avoiding the design complexity and added operational constraints associated with a common bulkhead configuration. The lower dome of the liquid oxygen tank extends downward into the intertank and the upper dome of the liquid hydrogen tank extends upward into the intertank.

The intertank includes a door 117 centimeters (46 inches) wide by 132 centimeters (52 inches) high for ground personnel access to the inside of the intertank, the forward manhole opening of the liquid hydrogen tank, and the aft manhole opening of the liquid oxygen tank.

PROPULSION SYSTEM

In addition to the propellants and the various subsystems required to feed propellant to the Orbiter, the External Tank also contains a tumble system which assures that the tank will break up upon reentry and fall within the designated ocean impact area after separation from the Orbiter. Because the tank is expendable, most fluid controls and valves for the main propulsion system operation are located in the reusable Orbiter. Thus, the attachment hardware is an integral part of the structures system.

Before oxidizer loading, the liquid oxygen and liquid hydrogen tanks are purged with gaseous helium to ensure dryness and to remove residual air. Propellant is supplied to the tanks from ground storage facilities through the same feedlines that deliver fuel to the Orbiter during launch. The loading operation is controlled from the ground by the use of ET-mounted propellant-level sensors. Ten sensors are mounted in each tank to indicate the level of propellant as the tanks fill. Should a problem occur during or after loading, both tanks can be drained either simultaneously or sequentially with the vent-relief valves closed and the tanks pressurized.

The propellant feed system is divided into four primary subsystems: liquid oxygen feed; liquid hydrogen feed; pressurization, vent relief, and tumbling; and environmental conditioning.

Liquid Oxygen Feed Subsystem

At launch, liquid oxygen is fed to the Orbiter engines at a rate of 72 340 kg/min (159 480 lb/min) or 63 588 liters/min (16 800 gal/min).

The feedline is a 43.2-centimeter (17-inch) insulated pipe made of aluminum and corrosion-resistant steel. It consists of eight sections of flexible and straight lines and elbows running from the aft dome of the liquid oxygen tank, through the intertank, along the outside of the liquid hydrogen tank and to the base of the Orbiter through an umbilical disconnect plate.

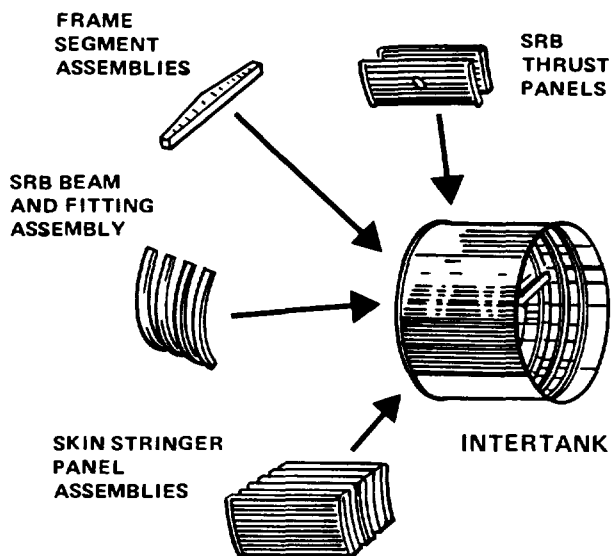

Figure 2-20.—ET intertank structural assembly.

A major component of the subsystem is an antigeyser line that runs alongside the liquid oxygen feedline and provides a circulation path to reduce accumulation of gaseous oxygen in the feedline. The buildup of a large gaseous oxygen bubble could push the liquid out into the tank, emptying the line. The subsequent refilling of the line from the tank could cause excessive pressure in the line beyond its design capability. This phenomenon is commonly known as a "water hammer effect." Another adjacent line provides helium, which is injected into the antigeyser line to maintain liquid oxygen circulation.

Liquid Hydrogen Feed Subsystem

Liquid hydrogen is fed to the Orbiter engines at 12 084 kg/min (26 640 lb/min) or 171 396 liters/min (45 283 gal/min) through a 43.2-centimeter (17-inch) diameter feedline made of aluminum and noncorrosive steel. One section of the line is insulated and runs from the aft dome to the base of the Orbiter through the umbilical disconnect plate. The other section is located inside the liquid hydrogen tank. This uninsulated internal feedline section consists of a bellows segment and a siphon segment; the siphon is incorporated inside the liquid hydrogen tank to maximize propellant use. Also incorporated in the subsystem is a liquid hydrogen recirculation line to prevent the formation of liquid air.

Pressurization, Vent Relief, and Tumbling Subsystem

During propellant loading, some of the liquid hydrogen and oxygen converts into gas. A dual-purpose valve for each propellant tank vents the gas and prevents excessive pressure buildup. Pressurized helium is used to pneumatically open the valves before propellant loading approximately 2 hours before launch. During the terminal sequence for launch, the valves are closed so the tank can be pressurized. After closing at launch, the valves act as safety-relief valves to protect against tank overpressurization. The maximum operating pressure of the liquid oxygen tanks is 152 kN/m² (22 psi) and the maximum operating pressure of the liquid hydrogen tanks is 234 kN/m² (34 psi).

During standby operations, the liquid oxygen and liquid hydrogen tanks are pressurized with gaseous helium to maintain a nominal positive pressure before loading and launch to avoid possible structural damage that could result from thermal and atmospheric pressure changes.

Approximately 3 minutes before launch, the tanks are pressurized until lift-off with helium piped from a ground facility. Following engine ignition at about T - 4 seconds, the ullage pressure is supplemented using propellant gases vaporized in the engine heat exchangers and routed to the two ET propellant tanks.

The tank pressure is maintained based on data inputs from ullage pressure sensors in each tank to control valves in the Orbiter. A combination of ullage and propellant pressure provides the necessary net positive suction pressure to start the engines. The net positive suction pressure is the pressure needed at the main engine pump inlets to cause the pumps to work properly. The pumps, in turn, supply high-pressure liquid oxygen and liquid hydrogen to the thrust chamber. Acceleration pressure is added for operation.

Fuel is forced to the engines primarily by tank pressures and, to a lesser degree, by gravity. Tank pressurization pushes fuel out of the tanks much like squeezing air out of a balloon.

The External Tank is jettisoned 10 to 15 seconds after Orbiter main engine cutoff. At separation, the ET tumble system is activated. The tumble system prevents aerodynamic skip during reentry, ensuring that tank debris will fall within the preplanned disposal location in the Indian Ocean. The tumble system is initiated by the firing of a 5-centimeter (2-inch) pyrotechnic valve by the separation signal. The valve, located in the nose cap, releases the pressurized gas from the liquid oxygen tank, causing the ET to spin at a minimal rate of 10 deg/s.

Environmental Conditioning

The environmental conditioning system is required to purge the inside of the intertank and sample the gas composition within the tank during propellant loading. During loading and until launch, the intertank is purged with dry gaseous nitrogen from the facility to render the compartment inert and avert any buildup of hazardous gases. A ground gas detection system, using a mass spectrometer, samples the environment during loading to detect any hazardous oxygen and/or hydrogen gas concentrations. Emergency actions would be initiated should such a hazardous gas concentration be detected.

ELECTRICAL SYSTEM

The electrical system provides propellant level and pressure sensing, instrumentation functions, electrical power distribution, tumbling initiation, and lightning protection. Basically, the system incorporates five categories of instrumentation and sensors and associated cabling. All instrumentation data are recorded in the Orbiter for transmittal to ground stations. All ET electrical power is provided by the Orbiter.

Instrumentation

The instrumentation is comprised of 38 sensors, which control ullage temperature, ullage pressure, liquid level, liquid hydrogen depletion, and vent valve position. The temperature sensor elements are made of platinum wire that changes resistance when subjected to cryogenic propellants.

Pressure sensors are installed on the liquid oxygen tank cover plate and on the liquid hydrogen tank dome cap and are mounted in a thermal insulator block of laminated glass fiber and phenolic resin. Each is connected to the tank through a pressure line, an adapter, and a gold-plated steel seal and is joined to the electrical cable through fixed-splice connections.

The tumbling system is activated before separation by signals from the Orbiter to a pyrotechnic valve inside the liquid oxygen tank

nose cap. This system includes a relay to prevent inadvertent firing.

Cabling

The cabling subsystem consists of cables, wiring, connectors, disconnect panels, and protected wire splices between the External Tank and the Orbiter. The cabling is designed to protect wiring before and during launch. Cable trays on the outside of the tank protect the cabling and are part of the ET structure. Five cables are routed across the External Tank from the Orbiter to the Solid Rocket Boosters to handle control signals and to monitor the condition of the boosters.

Lightning Protection

The tip of the nose cap forms a lightning rod to protect the tank during launch. Approximately 50.8 centimeters (20 inches) long, the rod is electrically bonded to the fairing over the gaseous oxygen line and then to the gaseous oxygen line itself. In addition, conductive paint strips provide an electrical path from the rod to the gaseous oxygen line. The current is then carried to the vehicle skin, across to the Orbiter, and out through the engine exhaust.

Lightning protection, which is primarily required for the liquid oxygen tank, is provided by the launch site until lift-off. Thereafter, the lightning rod protects the External Tank from the direct and indirect effects of lightning.

THERMAL PROTECTION SYSTEM

The outside of the External Tank is covered with a multilayered thermal protective coating to withstand the extreme temperature variations expected during prelaunch, launch, and early flight. The materials used are an outer spray-on polyurethane foam that covers the entire tank and an ablating material that provides additional protection for the portions of the tank subject to very high temperatures. Although the outer surface is covered with a thermal coating approximately 2.5 centimeters (1 inch) thick, the exact type of material, the thickness, and the application vary at different locations on the tank.

Polyisocyanurate foam insulation is applied over the oxygen tank, the intertank, and the hydrogen tank. This insulation primarily reduces the boiloff rate of the propellants; it also eliminates ice formation on the outside of the tanks due to the extremely cold propellants inside.

A high-temperature ablator, which ablates rather than chars, is applied to the ET nose cone, the aft dome of the liquid hydrogen tank, portions of the liquid hydrogen barrel, and in areas where projections are subject to high aerodynamic heating during flight.

During the ascent phase, the thermal protection system (TPS) maintains the primary structure and subsystem components within the design temperature limits and minimizes unusable liquid hydrogen resulting from thermal stratification. The system also aids the fragmentation process as the External Tank reenters the atmosphere after separation from the Orbiter. It affects the structural and gas temperatures, which ensure the necessary debris size, reentry trajectory, and desired impact area.

Each of the main elements of the External Tank has its own TPS requirement, determined on the basis of environments and mission conditions. The thermal protection is applied to the tank while it is in an upright position. The tank rotates on a turntable as automatic sprayers apply the foam under controlled temperature, humidity, and cleanliness conditions. However, the thermal protection is applied manually to the major connecting areas of the tank to ensure that all surfaces are insulated as required. Premolded sections of TPS are used where spray operations are prohibited because of accessibility or cleanliness constraints.

INTERFACE HARDWARE

As the largest and most central element of the Space Shuttle, the External Tank provides interconnections, or interfaces, with the Orbiter, the Solid Rocket Boosters, and ground supports. These interfaces are made through fluid and electrical umbilical links and large structural accommodations.

External Tank/Solid Rocket Booster Interfaces

Four attachment points on each side of the External Tank link the tank with the two Solid Rocket Boosters. Each booster is connected by one forward attachment located on one side of the intertank and three aft stabilization connect points attached to the ET aft major ring frame. The second booster is attached in exactly the same way on the opposite side. Adjustment provisions are located on the sides of each SRB interface to align the ET and the SRB centerlines on the same geometric plane. Pullaway electrical interfaces are located on the aft stabilization struts. The boosters contain the attachment hardware, consisting of bolts and pins, to receive the interfaces and accomplish separation. The ET side of these interfaces remains passive at separation.

External Tank/Orbiter Interfaces

Three structural interfaces — two aft and one forward — link the External Tank and the Orbiter. The two aft interfaces are tripods located at the ET aft major ring frame and the liquid hydrogen tank longerons. The forward interface is supported from the liquid hydrogen tank forward ring frame. Numerous pinned and spherical joints allow for multidirectional motion and minimize bending induced by thermal and structural load environments.

All ET/Orbiter structural interface attachment hardware is provided by the Orbiter. Orbiter systems control the separation of the External Tank from the Orbiter following main engine cutoff. The ET/Orbiter fluid and electrical interfaces are located at two aft umbilical assemblies adjacent to the two ET aft structural interfaces. These umbilical assemblies consist of clustered disconnects that mate with the ET fluid lines and electrical cables. Both are used to provide redundancy for ET/Orbiter and Orbiter/SRB electrical interfaces.

External Tank/Facilities Interfaces

The External Tank and the ground fluid and pneumatic systems are linked through an umbilical connector from the intertank. This interface, known as the ground umbilical carrier plate, controls vent valve actuation, helium injection into the liquid oxygen antigeyser line, atmosphere monitoring, and conditioning of the intertank cavity. It also ducts gaseous hydrogen boiloff.

The ground umbilical carrier plate is disconnected at SRB ignition by initiation of a pyrotechnic separation bolt. A lanyard system is provided to back up the pyrotechnic system. The lanyard system pulls the bolt out on the flight side as the vehicle lifts off. The umbilical plate is made of cast aluminum and weighs approximately 60 kilograms (130 pounds). It interfaces with the External Tank through a peripheral Teflon seal and rests against the intertank outer skin when mated.

3. ORBITER STRUCTURE



3. ORBITER STRUCTURE

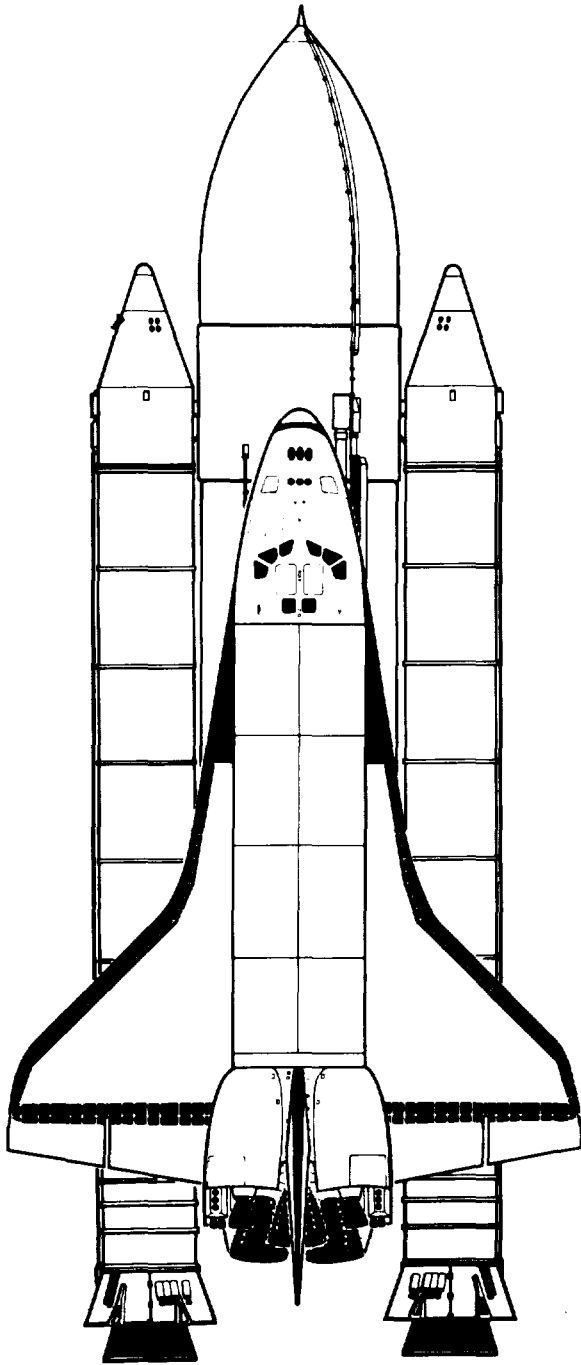

FORWARD FUSELAGE	3-5
Crew Module	3-6
Flight Deck	3-6
Mid Deck	3-10
Airlock	3-11
Transfer Tunnel and Tunnel Adapter	3-12
Docking Module	3-12
MID FUSELAGE	3-13
PAYLOAD ACCOMMODATIONS	3-15
AFT FUSELAGE	3-17
WING	3-20
VERTICAL STABILIZER	3-22
MECHANICAL SUBSYSTEMS	3-23
Landing Gear	3-24
Separation and Pyrotechnic Subsystem	3-24
Hatches	3-25

Briefly . . .

The cockpit, living quarters, and experiment operator's station are located in the forward fuselage of the Orbiter vehicle. Payloads are carried in the mid-fuselage payload bay, and the Orbiter's main engines and maneuvering thrusters are located in the aft fuselage.

TOTAL LENGTH

37.24 meters (122.17 feet)

HEIGHT

17.25 meters (56.58 feet)

VERTICAL STABILIZER

8.01 meters (26.31 feet)

WINGSPAN

23.79 meters (78.06 feet)

BODY FLAP

12.6 square meter (135.8 square foot) area

6.1 meters (20 feet) wide

AFT FUSELAGE

5.5 meters (18 feet) long

6.7 meters (22 feet) wide

6.1 meters (20 feet) high

MID FUSELAGE

18.3 meters (60 feet) long

5.2 meters (17 feet) wide

4.0 meters (13 feet) high

FORWARD FUSELAGE

CREW CABIN

71.5 cubic meters (2525 cubic foot) volume

PAYLOAD BAY DOORS

18.3 meters (60 feet) long

4.6 meters (15 feet) in diameter

148.6 square meters (1600 square feet) surface area

WING

18.3 meters (60 feet) long

1.5 meter (5 foot) maximum thickness

ELEVONS

4.2 meters (13.8 feet)

3.8 meters (12.4 feet)

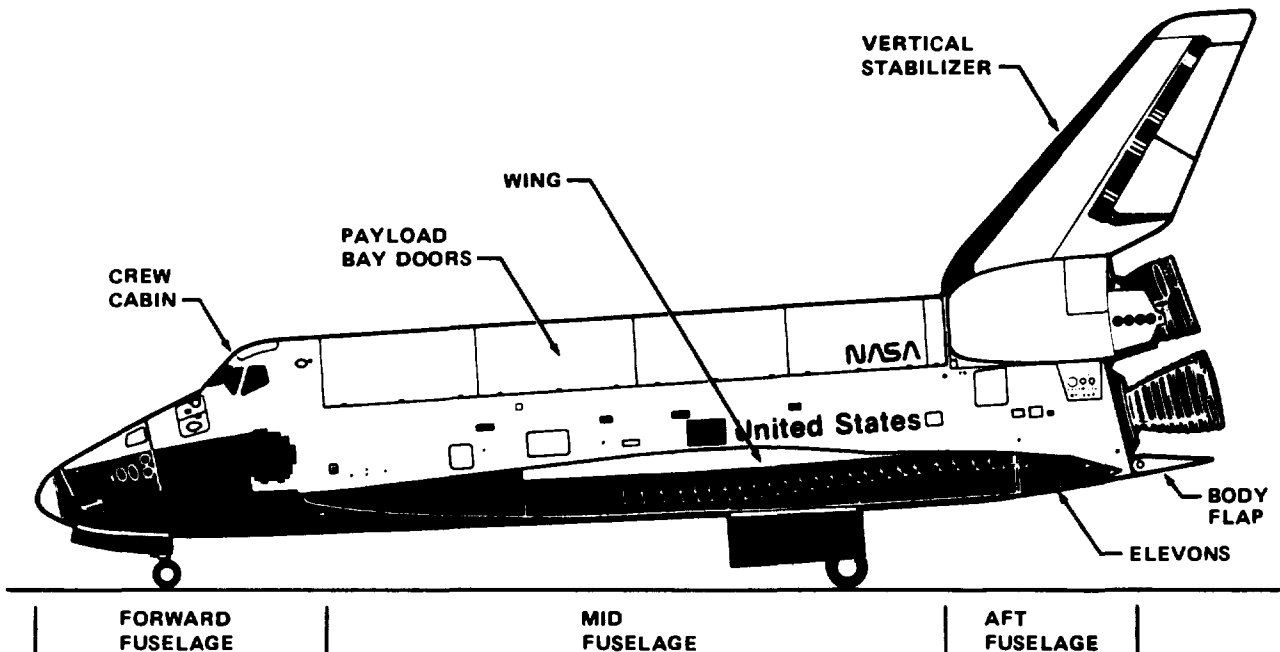

3. ORBITER STRUCTURE

The Orbiter structure consists of the forward fuselage (upper and lower forward fuselage and the crew module), the wings, the mid fuselage, the payload bay doors, the aft fuselage, and the vertical stabilizer. Most of the Orbiter structures are constructed of conventional aluminum. A cutaway view of the Orbiter structures is shown in figure 3-1; dimensions of the Orbiter are given in figure 3-2.

FORWARD FUSELAGE

The "cockpit," living quarters, and experiment operator's station are located in the forward fuselage. This area houses the pressurized crew module and provides support for the nose section, the nose gear, and the nose gear wheel well and doors.

The forward fuselage (fig. 3-3) is of conventional aircraft construction with type 2024 aluminum alloy skin-stringer panels, frames, and bulkheads. The panels are composed of single-curvature stretch-formed skins with riveted stringers spaced approximately 8 to 13 centimeters (3 to 5 inches) apart. The frames are riveted to the skin-stringer panels. The spacing between the major frames is 76.2 to 91.4 centimeters (30 to 36 inches). The forward bulkhead is constructed of flat aluminum and formed sections (upper), riveted and bolted together, and a machined section (lower). The bulkhead provides the

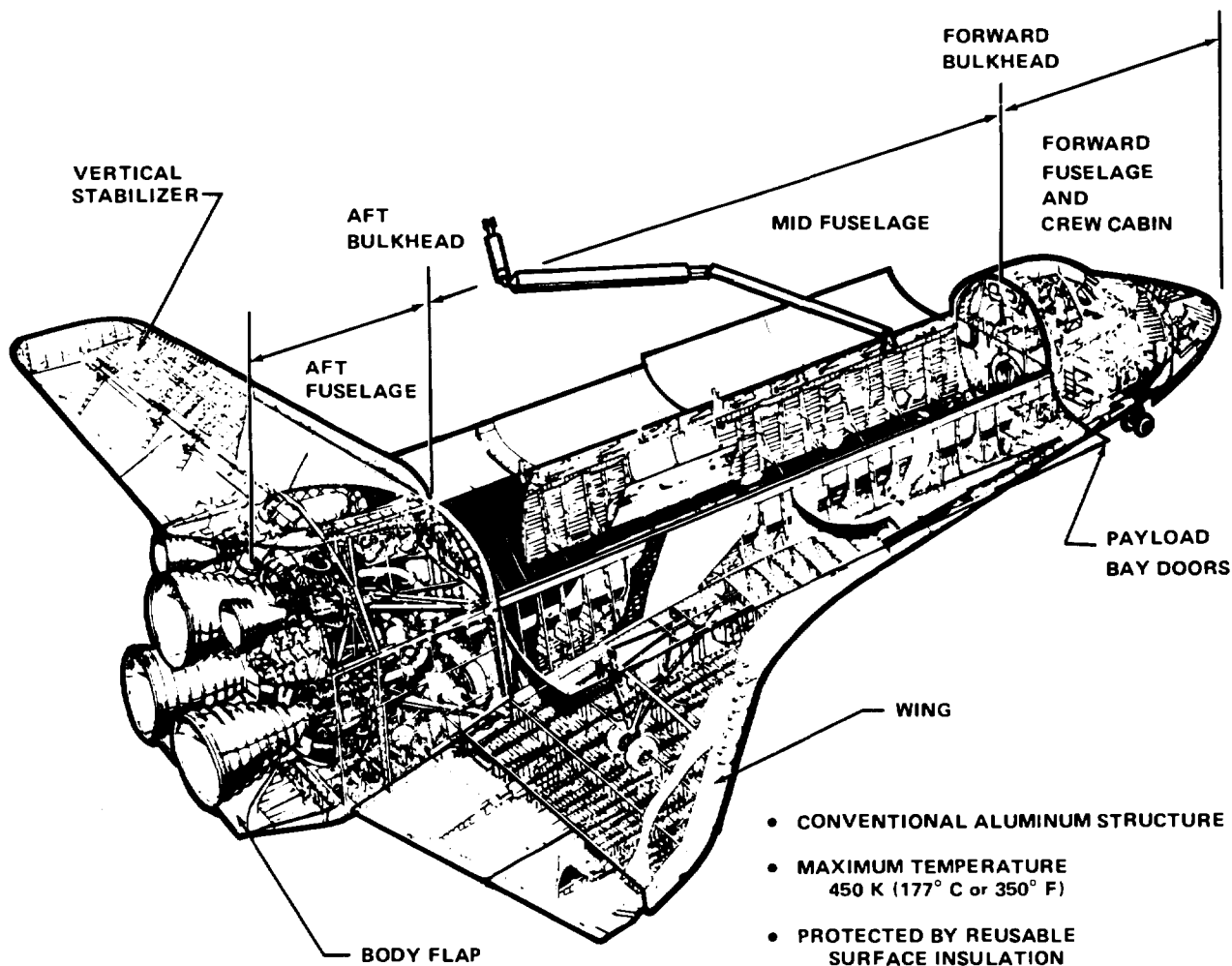

Figure 3-1.—Orbiter structures.

interface fitting for the nose section, which contains large machined beams and struts. The two nose landing gear doors are constructed of aluminum alloy honeycomb and have aerodynamic seals. Structural provisions are provided in the forward fuselage skin for the installation of antennas and air data sensors.

The forward reaction control system (RCS), which is constructed of aluminum, houses the RCS engines and tank and is attached to the forward fuselage at 16 attach points.

Crew Module

The 71.5-cubic-meter (2525-cubic-foot) crew station module (fig. 3-4) is a three-section pressurized working, living, and stowage compartment in the forward portion of the Orbiter. It consists of the flight deck, the mid deck/

equipment bay, and an airlock. Outside the aft bulkhead of the crew module in the payload bay, a docking module and a transfer tunnel with an adapter can be fitted to allow crew and equipment transfer for docking, Spacelab, and extravehicular operations.

The two-level crew module has a forward flight deck with the commander's seat positioned on the left and the pilot's seat on the right.

Flight Deck

The flight deck (fig. 3-5) is designed in the usual pilot/copilot arrangement, which permits the vehicle to be piloted from either seat and permits one-man emergency return. Each seat has manual flight controls, including rotation and translation hand controllers, rudder pedals, and speed-brake controllers. The flight deck seats four. The

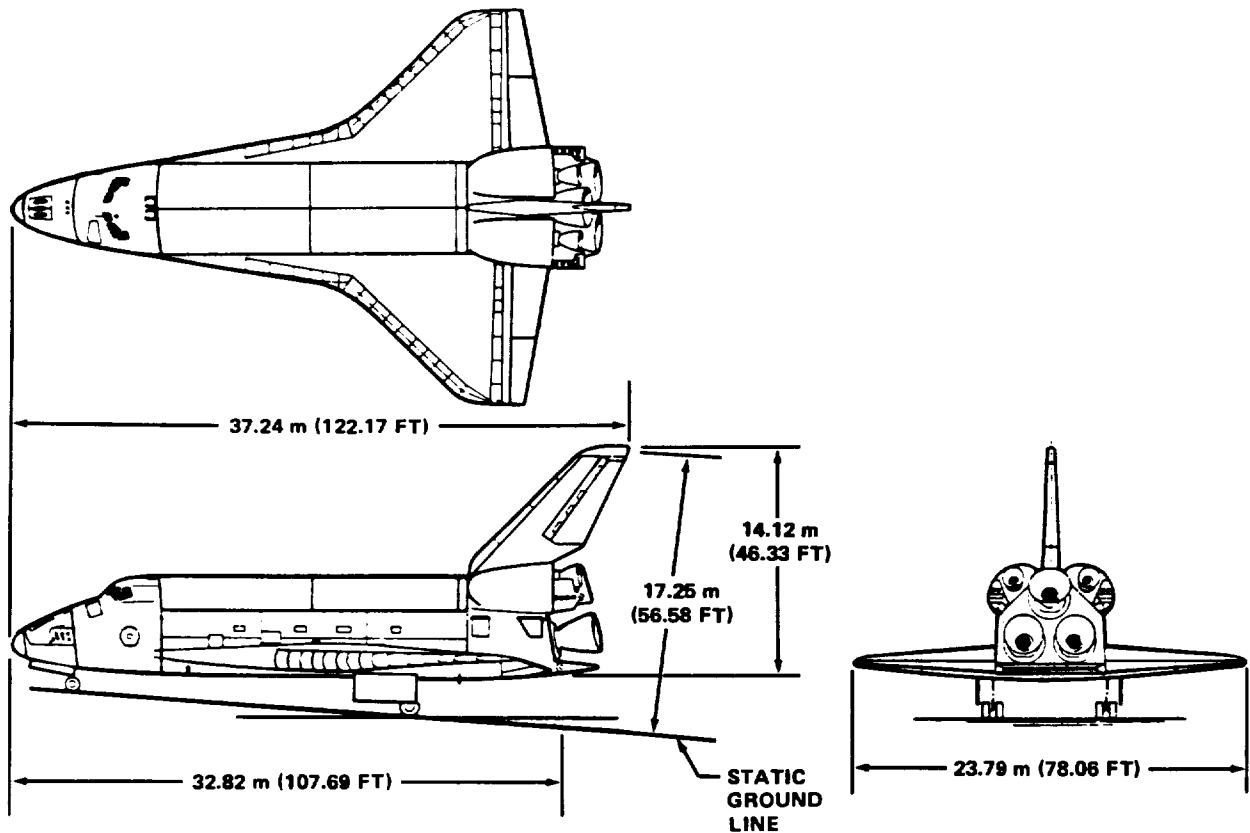
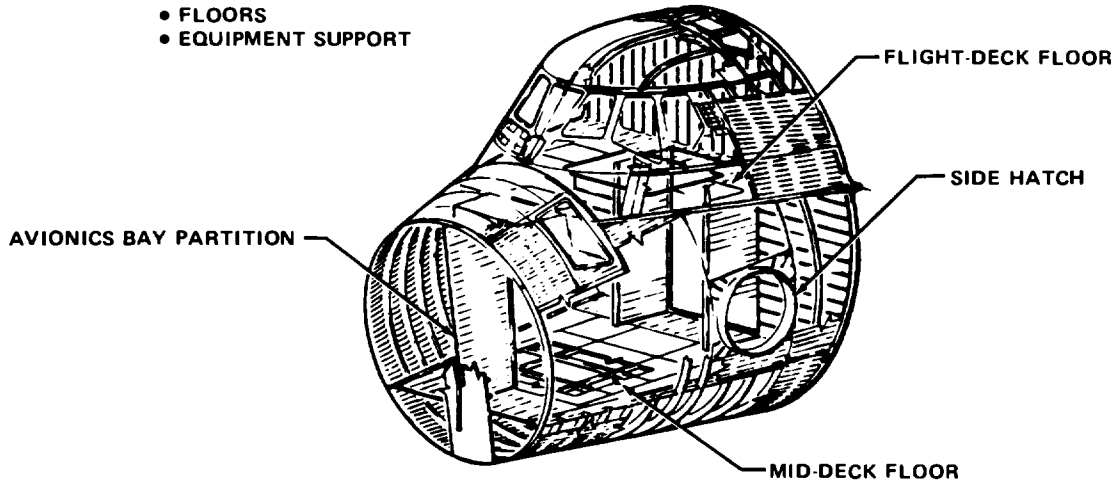

Figure 3-2.—Dimensions of the Orbiter vehicle.

- INTEGRALLY MACHINED ALUMINUM SKIN-STRINGER PANELS
- WELDED CONSTRUCTION
- MECHANICALLY ATTACHED
 - FRAMES
 - BEAMS
 - FLOORS
 - EQUIPMENT SUPPORT



(a) Crew module.

- ALUMINUM CONSTRUCTION
- RIVETED SKIN/STRINGER/FRAME STRUCTURE

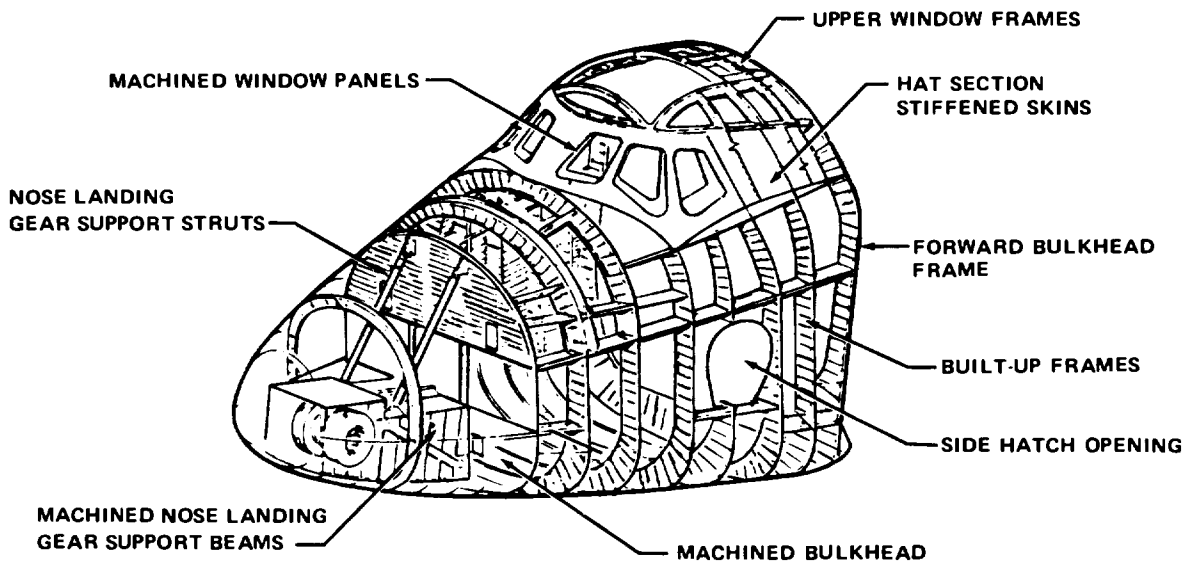

(b) Structure.

Figure 3-3.—Forward fuselage.

onorbit displays and controls at the aft end of the flight deck/crew compartment are shown in figure 3-6. The displays and controls on the left are for operating the Orbiter and those on the right are for operating and handling the payloads.

More than 2020 separate displays and controls are located on the flight deck. These include toggle switches, circuit breakers, rotary switches, pushbuttons, thumbwheels, metered and mechanical readouts, and separate indicating lights. The displays and controls onboard the Orbiter represent approximately three times more than those onboard the Apollo command module.

The payload-handling portion of the onorbit station contains displays and controls required to manipulate, deploy, release, and capture payloads. Displays and controls are provided at this station to open and close payload bay doors; to deploy radiators; to deploy, operate, and stow manipulator arms; and to operate payload-bay-mounted lights and television cameras. Two closed-circuit television monitors display the payload bay video pictures for monitoring payload manipulation operations.

The rendezvous and docking portion of the onorbit station contains displays and controls required to execute Orbiter attitude/translation maneuvers for terminal-phase rendezvous and docking. Rendezvous radar displays and controls and cross-pointer displays of pitch and roll angles and rates are provided at this station, as well as rotation and translation hand controllers, flight control mode switches, and attitude direction indicators.

The mission station is located aft of the pilot's station on the right side and has displays and controls for Orbiter-to-payload interfaces and payload subsystems. An auxiliary caution-and-warning display at this station alerts the crew to critical malfunctions detected in the payload systems. The station manages Orbiter subsystem functions that do not require immediate access and onorbit housekeeping. A cathode-ray-tube (television screen) display and keyboard are located at this station for monitoring payloads and Orbiter subsystems. Payload conditions during ascent and entry can also be displayed at the forward flight stations by caution-and-warning and television displays.

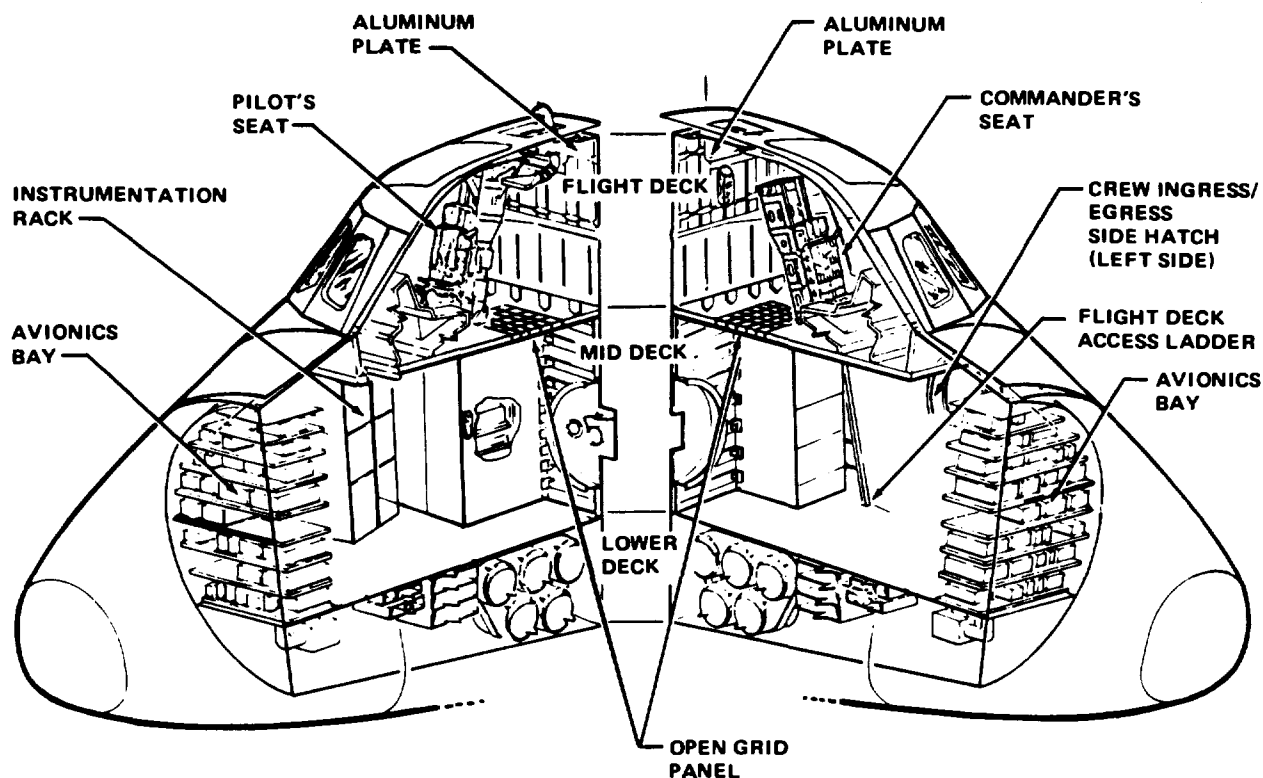

Figure 3-4.— Crew module layout.

Six pressure windshields, two overhead windows, and two rear-viewing payload bay windows are located on the upper flight deck of the crew module, and a window is located in the crew entrance/exit hatch located in the mid section, or deck, of the crew module.

The six windshields on the flight deck of the crew module that provide pilot visibility are the largest pieces of glass ever produced with the optical quality required for "see-through" viewing. Each of the six outer windshields is constructed of silica glass for high optical quality and thermal

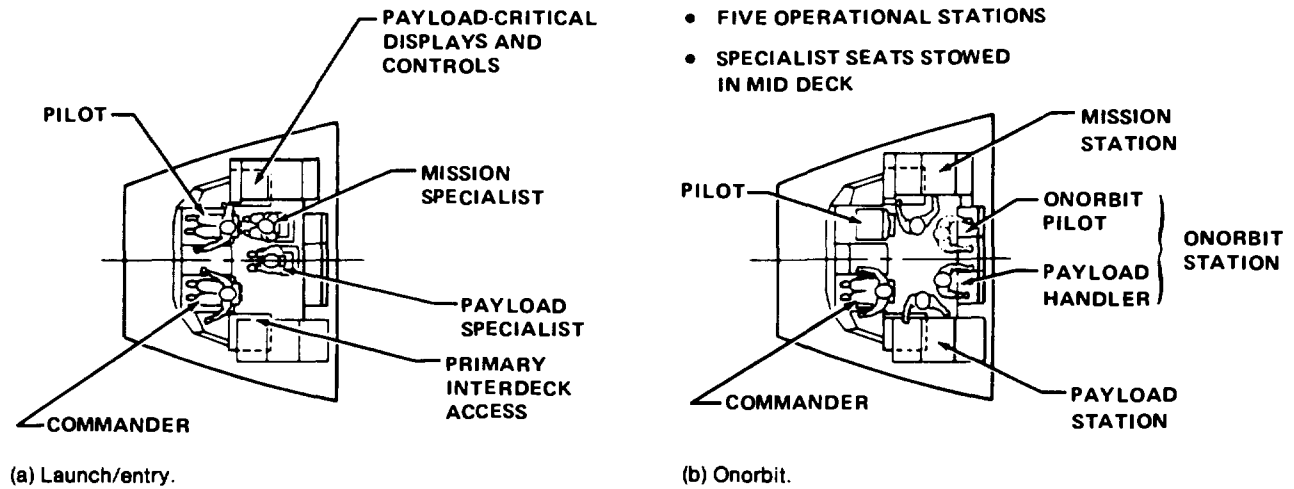

Figure 3-5.— Flight-deck crew cabin arrangement.

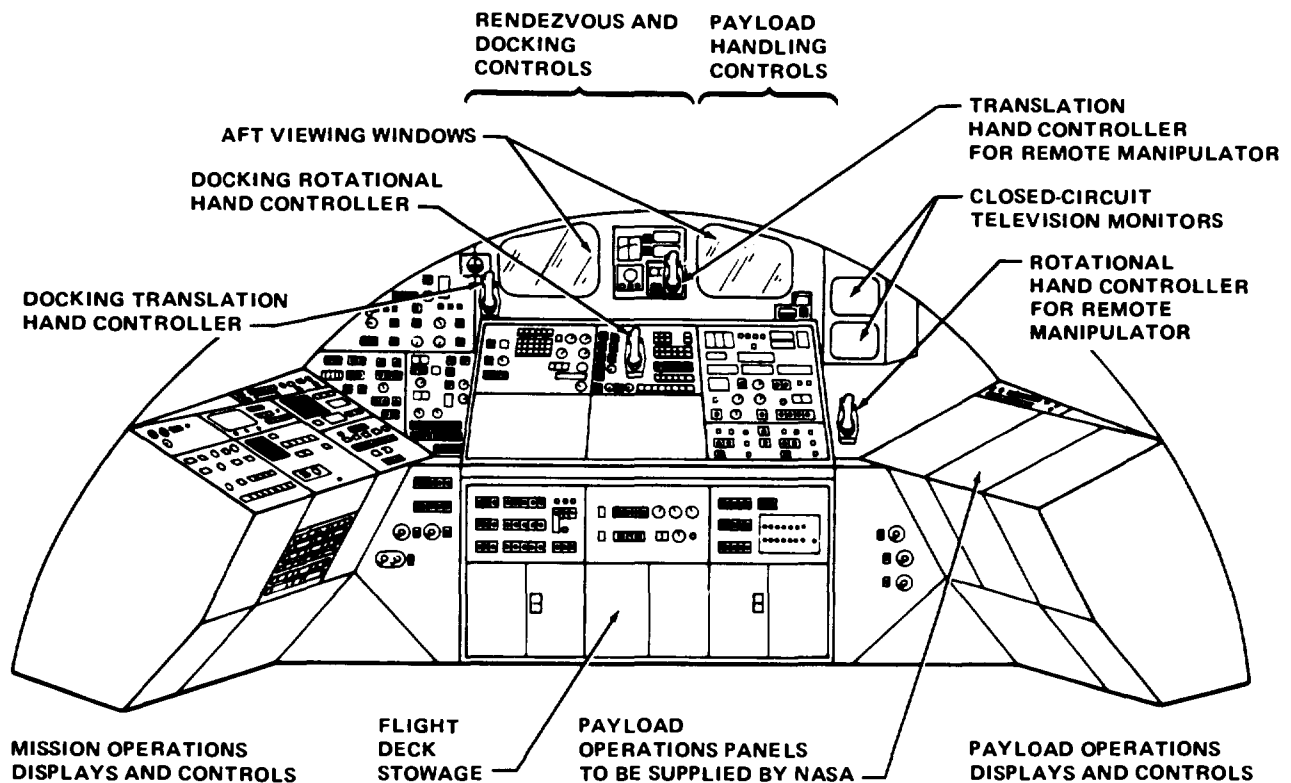

Figure 3-6.— Aft flight-deck configuration.

shock resistance. The construction of the overhead windows is identical to that of the windshields with the exception of the center pane, which is made of tempered aluminosilicate instead of fused silica glass. The rear-viewing payload bay window consists of two panes of tempered aluminosilicate glass because no thermal (outer) window is required. The side hatch (mid deck), which is 101.6 centimeters (40 inches) in diameter, has a clear-view window 25.4 centimeters (10 inches) in diameter in the center of the hatch. The window consists of three panes of glass identical in construction to the six windshields of the Orbiter.

Mid Deck

The mid deck (fig. 3-7) contains provisions and storage facilities for four crew sleep stations. Storage for the lithium hydroxide canisters and other gear, the waste management system, the personal hygiene station, and the work/dining table is also provided in the mid deck.

The nominal maximum crew size is seven. The mid deck can be reconfigured by adding three rescue seats in place of the modular storage and sleeping provisions. The seating capacity will then accommodate the rescue flightcrew of three and a maximum rescued crew of seven.

Access to the mid deck from the flight deck is through two 66- by 71-centimeter (26- by 28-inch) interdeck access hatches and, from the exterior, through the Orbiter side hatch. A ladder attached to the port interdeck hatch permits easy ground entry by the crew and ground crew from the mid deck to the flight deck. The airlock allows passage to the payload bay.

Environmental control equipment and additional storage space are located below the mid deck. Expended lithium hydroxide canisters and wet trash are also stowed below the mid-deck floor. Access to the environmental control equipment is possible through removable floor panels.

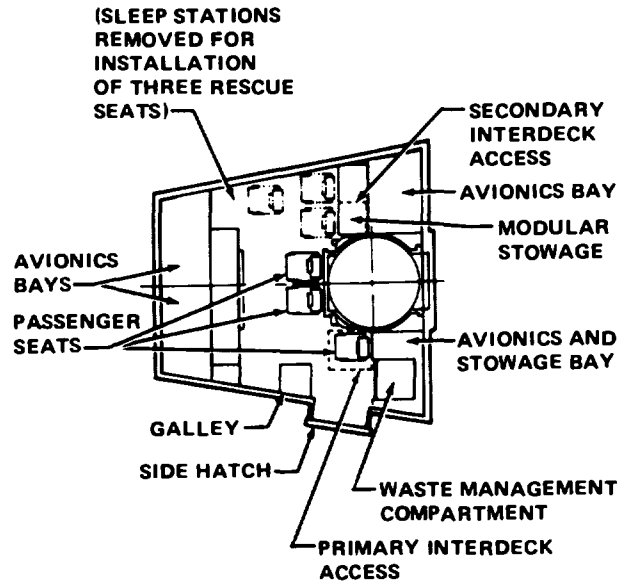

(a) Launch/entry.

- WORKING/HABITABILITY PROVISIONS FOR FOUR PERSONNEL (NOMINAL)

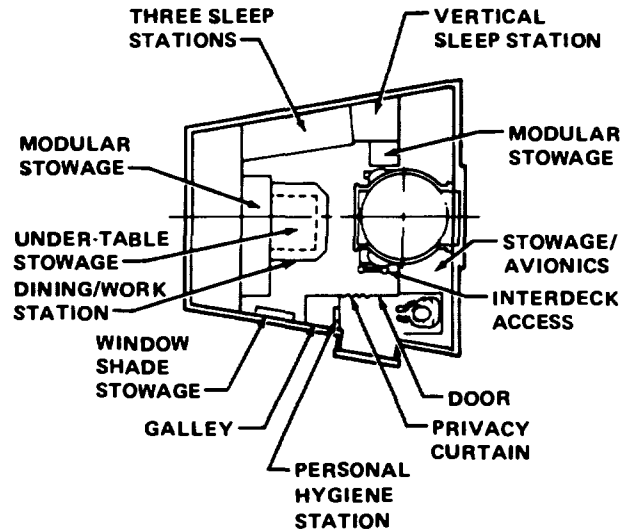

(b) Onorbit.

Figure 3-7.—Mid-deck crew cabin arrangement.

Airlock

The airlock (fig. 3-8) provides access for extravehicular activity (EVA). It can be located in one of several places: inside the Orbiter crew module in the mid-deck area mounted to the aft bulkhead, outside the cabin also mounted to the aft bulkhead, or on top of a tunnel adapter that can connect the pressurized Spacelab module with the Orbiter cabin. A docking module can also serve as an EVA airlock.

The airlock; two space suits; expendables for two 6-hour payload EVA's and one contingency or emergency EVA; and mobility aids such as handrails enable the crew to perform a variety of tasks. (See section 5.)

The airlock is cylindrical with an inside diameter of 160 centimeters (63 inches) and a length of 211 centimeters (83 inches). The airlock allows two crewmen room for changing space suits. The hatches are D-shaped. The flat side of the D makes the minimum clearance 91.4 centimeters (36 inches). The shape, size, and location of the hatches allow the two crewmen to move a package 46 by 46 by 127 centimeters (18 by 18 by 50 inches) through the airlock.

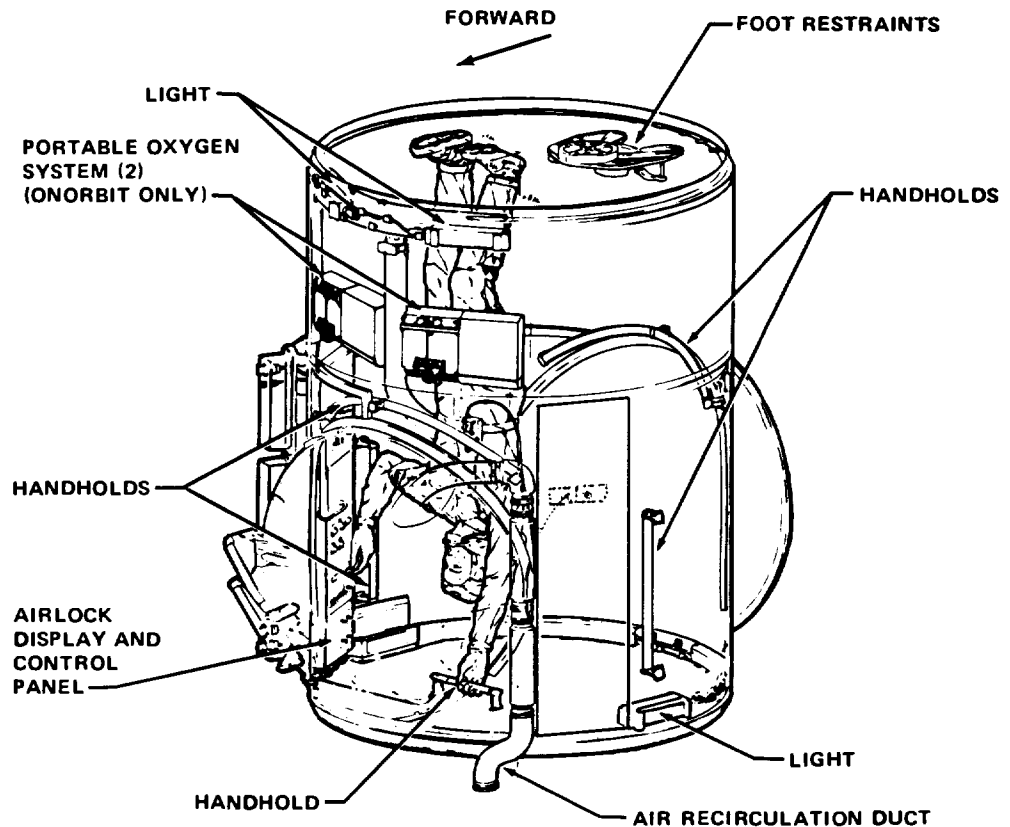

Figure 3-8.—Orbiter airlock.

Transfer Tunnel and Tunnel Adapter

The transfer tunnel and the tunnel adapter (fig. 3-9) provide for transfer of the crew and equipment between the Spacelab and the crew module. The tunnel has flexible elements and a number of segments to accommodate different flight locations. The tunnel mates with the tunnel adapter at the forward end of the payload bay for operations outside the crew module and for rescue when a docking module is not carried. Electrical and fluid interface lines between the Orbiter and the Spacelab extend along the exterior of the tunnel.

The tunnel adapter has two access hatches: one on top for access to an airlock and the other on the aft end for access to the payload bay. For operations outside the crew module, the airlock will be placed on top of the tunnel adapter.

Docking Module

For missions requiring direct docking of two vehicles, a docking module can be substituted for the airlock and installed on the tunnel adapter (fig. 3-9). The docking module is extendable and provides an airlock function for EVA for two crewmembers when extended or for one crewmember when retracted.

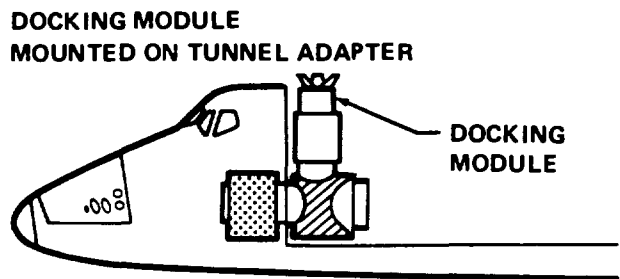
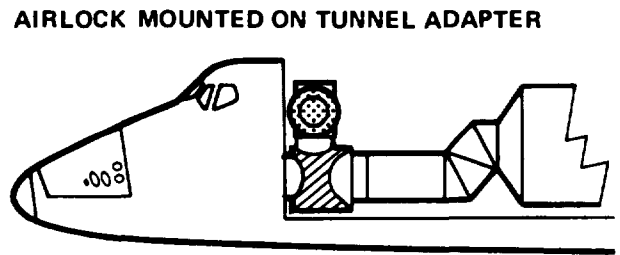
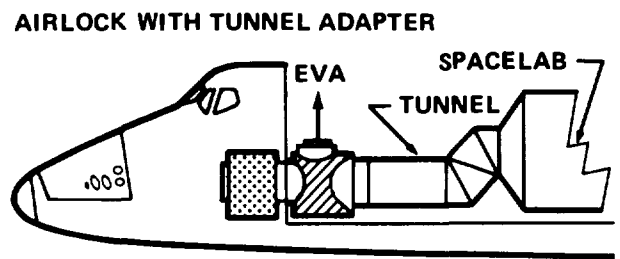
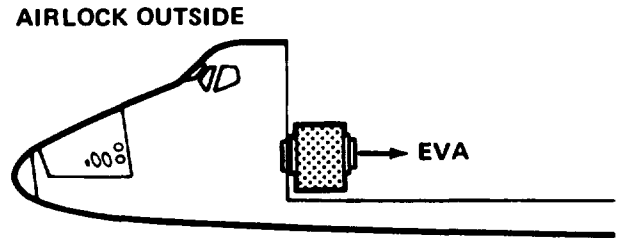
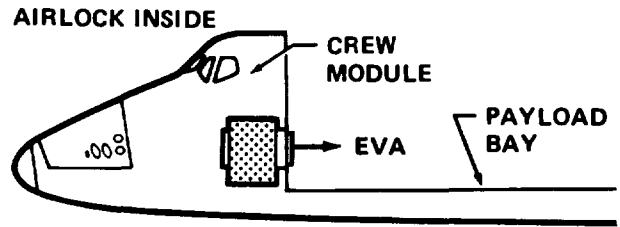

Figure 3-9.— Airlock/tunnel adapter/docking module configurations.

MID FUSELAGE

The mid-fuselage structure (fig. 3-10) interfaces with the forward fuselage, the aft fuselage, and the wings and, in addition to forming the payload bay of the Orbiter, supports the payload bay doors, hinges, and tiedown fittings; the forward wing glove; and various Orbiter system components.

The forward and aft ends of the mid fuselage join the bulkheads of the forward and aft fuselage. The length of the mid fuselage is 18.3 meters (60 feet), the width is 5.2 meters (17 feet), and the height is 4.0 meters (13 feet). The mid fuselage weighs approximately 6124 kilograms (13502 pounds).

There are 12 main-frame assemblies that stabilize the mid-fuselage structure. These assemblies consist of vertical side and horizontal elements. The side elements are machined, whereas the horizontal elements have machined flanges with boron/aluminum tube trusses. The boron/aluminum tubes (tubular struts) have diffusion-bonded titanium end fittings that provide substantial weight savings.

The upper portion of the mid fuselage consists of the sill and door longerons. The machined sill longerons are not only the primary body-bending elements but also serve to support the longitudinal loads from payloads in the payload bay. There are 13 payload bay door hinges attached to the payload bay door longerons and associated backup structure.

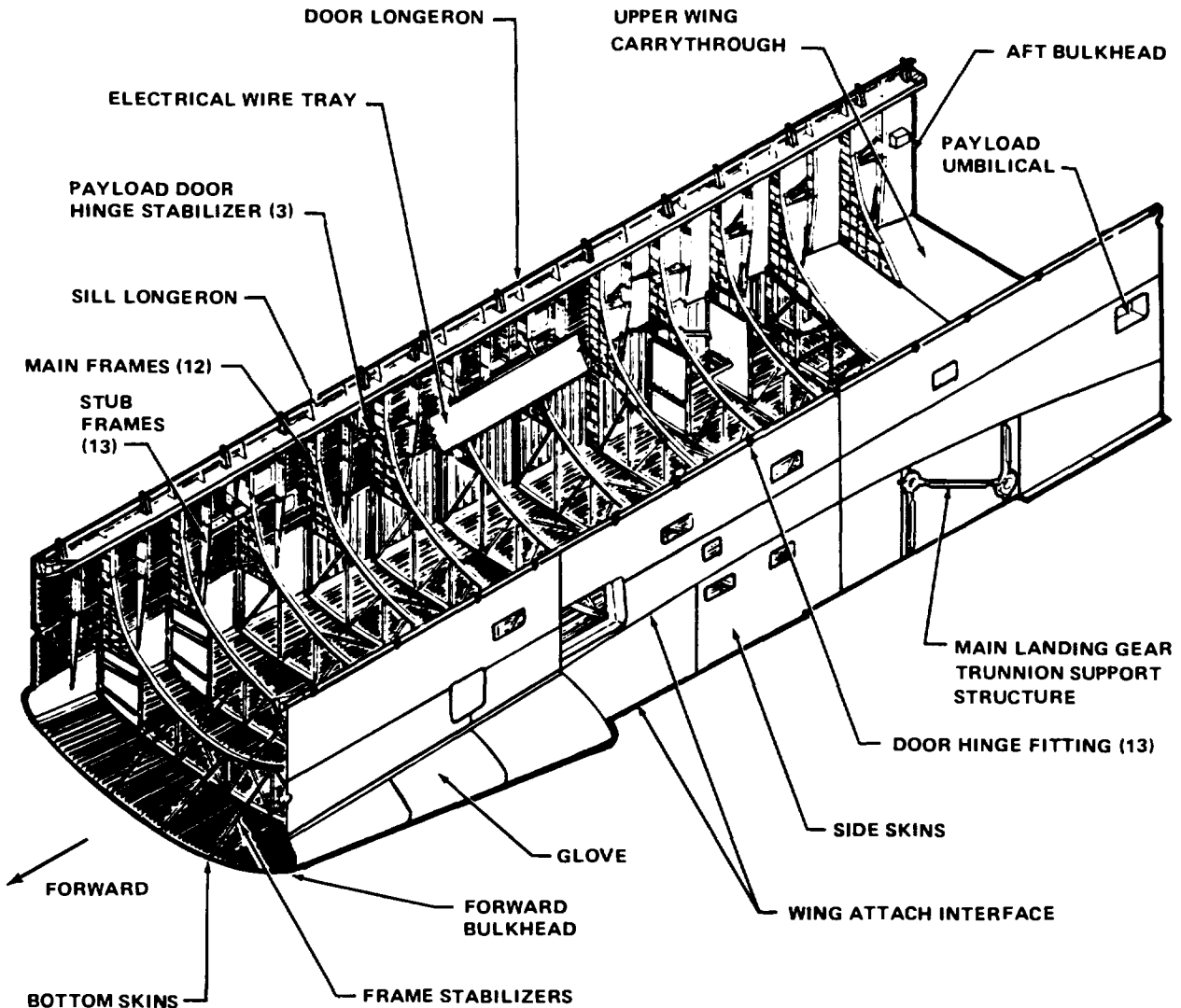

Figure 3-10.— Mid fuselage.

The payload bay doors (fig. 3-11) consist of a left-hand and a right-hand door that are hinged to the mid fuselage and latched at the forward and aft fuselage and at the top centerline of each door. The doors provide an opening for payload deployment and retrieval and serve as structural support for the Orbiter radiators. The payload bay is not pressurized.

The doors are 18.3 meters (60 feet) long and 4.6 meters (15 feet) in diameter and are constructed of graphite/epoxy composite material. The doors weigh 1480 kilograms (3264 pounds). Each door supports four radiator panels. The forward two radiator panels on each door can be tilted, but the aft two radiators remain fixed. When the doors are opened, the tilting radiators are unlatched and moved to the proper position. This allows heat radiation from both sides of the panels, whereas the four aft radiator panels radiate from the upper side only.

The controls for operating the payload bay doors and positioning the radiator panels are located at the aft station on the flight deck. The crew has the capability of selecting automatic or manual operation. In the automatic mode, all sequences are performed automatically after proper switch initiation, whereas the manual mode allows the crew to select latch group opening or closing sequences.

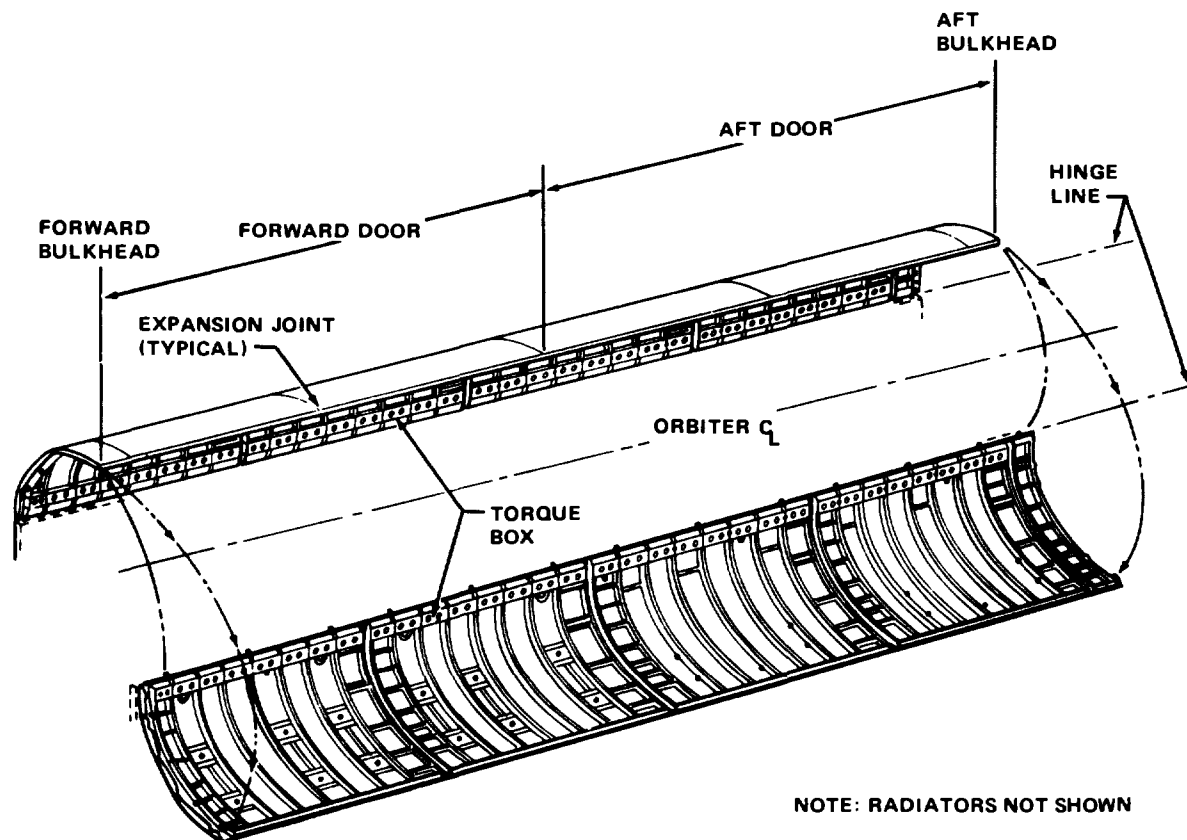

Figure 3-11.— Payload bay doors.

PAYLOAD ACCOMMODATIONS

Structural attach points for payloads are located at 9.9-centimeter (3.9-inch) intervals along the tops of the two Orbiter mid-fuselage main longerons. Some payloads may not be attached directly to the Orbiter but to payload carriers that are attached to the Orbiter. The inertial upper stage, Spacelab and Spacelab pallet, or any specialized cradle for holding a payload are typical carriers.

The remote manipulator system (RMS) is a 15.2-meter (50-foot) long articulating arm that is remotely controlled from the flight deck of the Orbiter (fig. 3-12). The elbow and wrist movements of the RMS permit payloads to be grappled for deployment out of the payload bay attach points or to be retrieved and secured for return to Earth. Because the RMS can be operated

from the shirt-sleeve environment of the cabin, an EVA maneuver is not required.

The standard remote manipulator is mounted with its "shoulder" on the left main longeron (facing forward); a second manipulator can be mounted on the right longeron for handling certain types of payloads.

A television camera and lights near the outer end of the RMS arm permit the operator to see on television monitors what his "hands" are doing. Payloads will carry markings and alignment aids to help the RMS operator maneuver payloads. The RMS operator has a 62° field of view out the two aft windows on the flight deck and 80° through the two overhead observation windows (fig. 3-13). Three floodlights are located along each side of the payload bay.

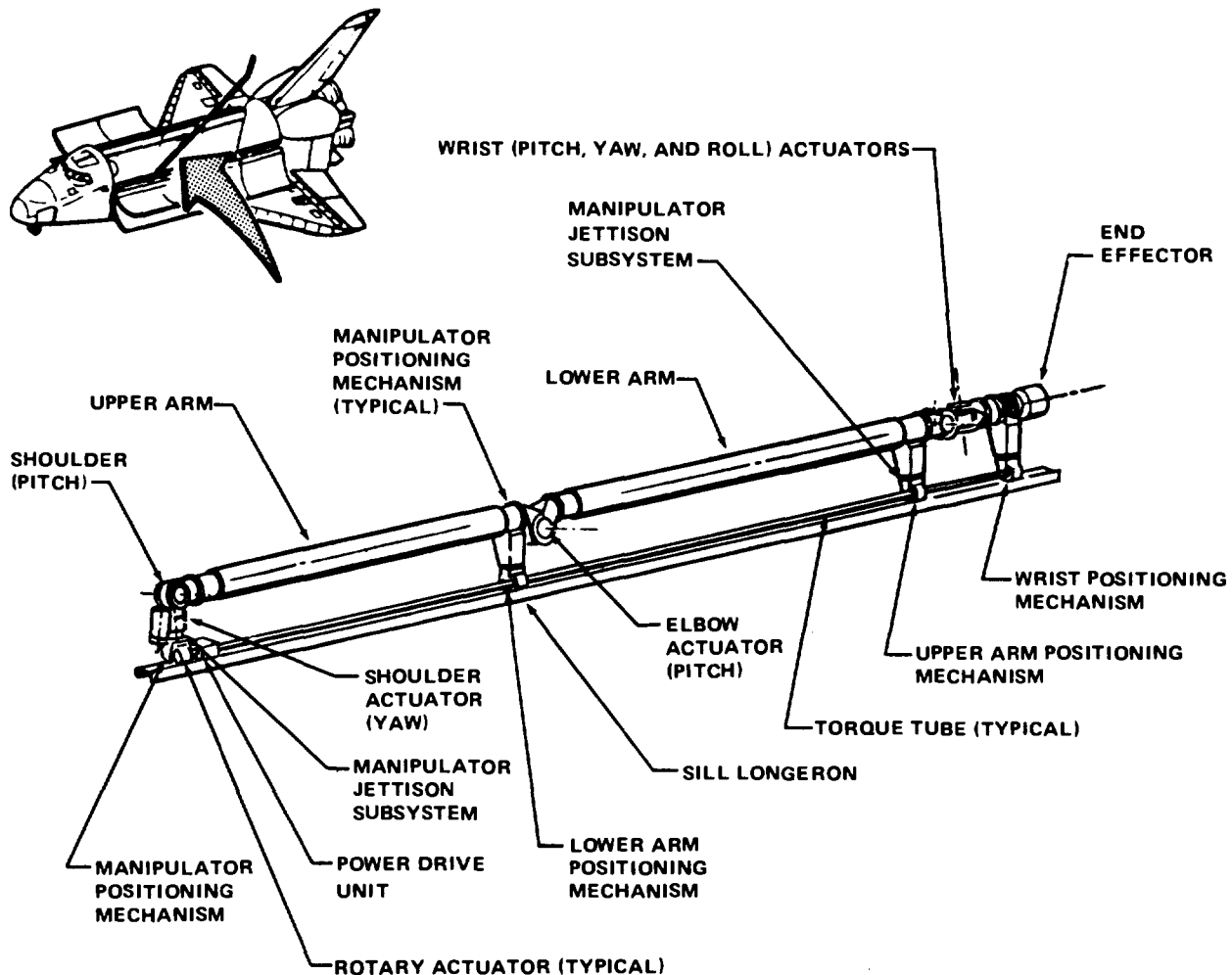

Figure 3-12.— Remote manipulator arm.

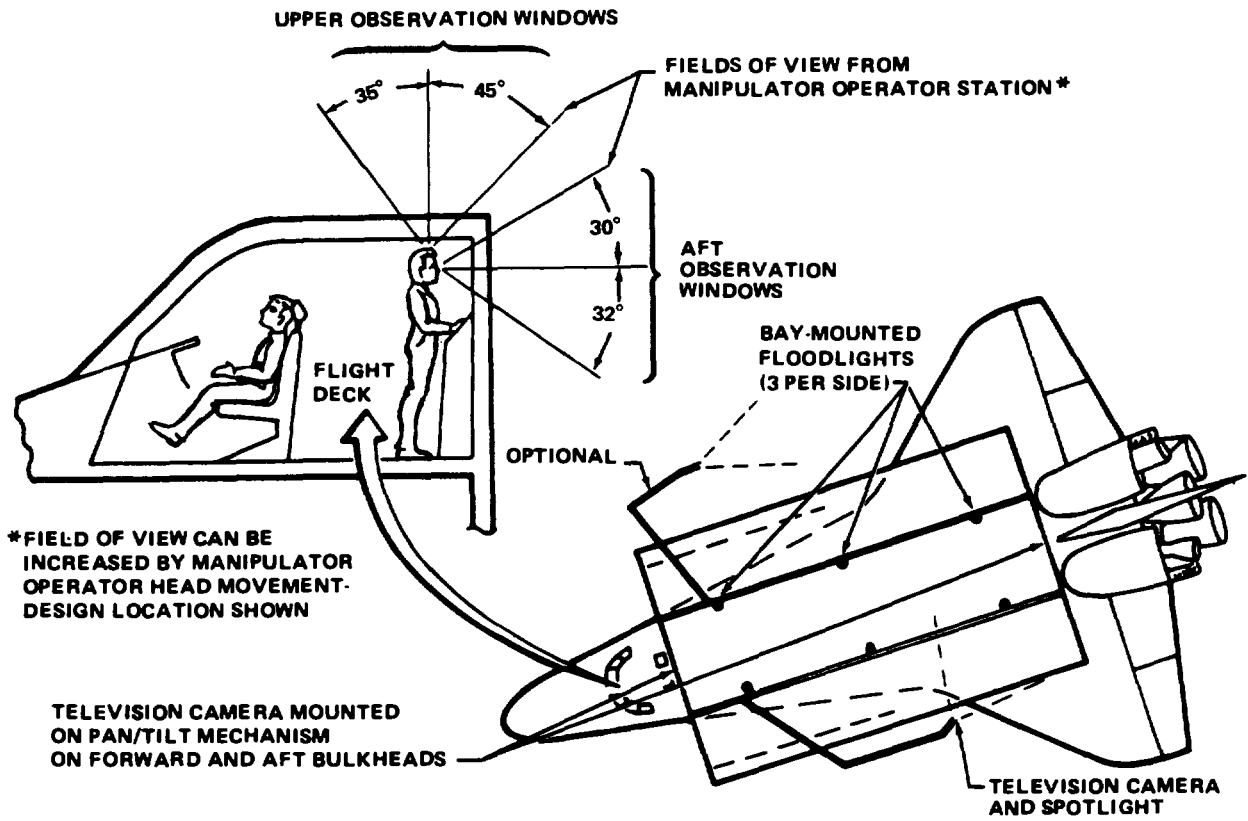

Figure 3-13.— Visual observation of payloads.

AFT FUSELAGE

The aft fuselage (fig. 3-14) is approximately 5.5 meters (18 feet) long, 6.7 meters (22 feet) wide, and 6.1 meters (20 feet) high. It carries and interfaces with the orbital maneuvering system/RCS pod (left and right sides), wing aft

spar, mid fuselage, Space Shuttle Main Engines (SSME's), heat shield, body flap, and vertical stabilizer.

The aft fuselage provides (1) the load path to the mid-fuselage main longerons, (2) main wing spar continuity across the forward bulkhead of the aft

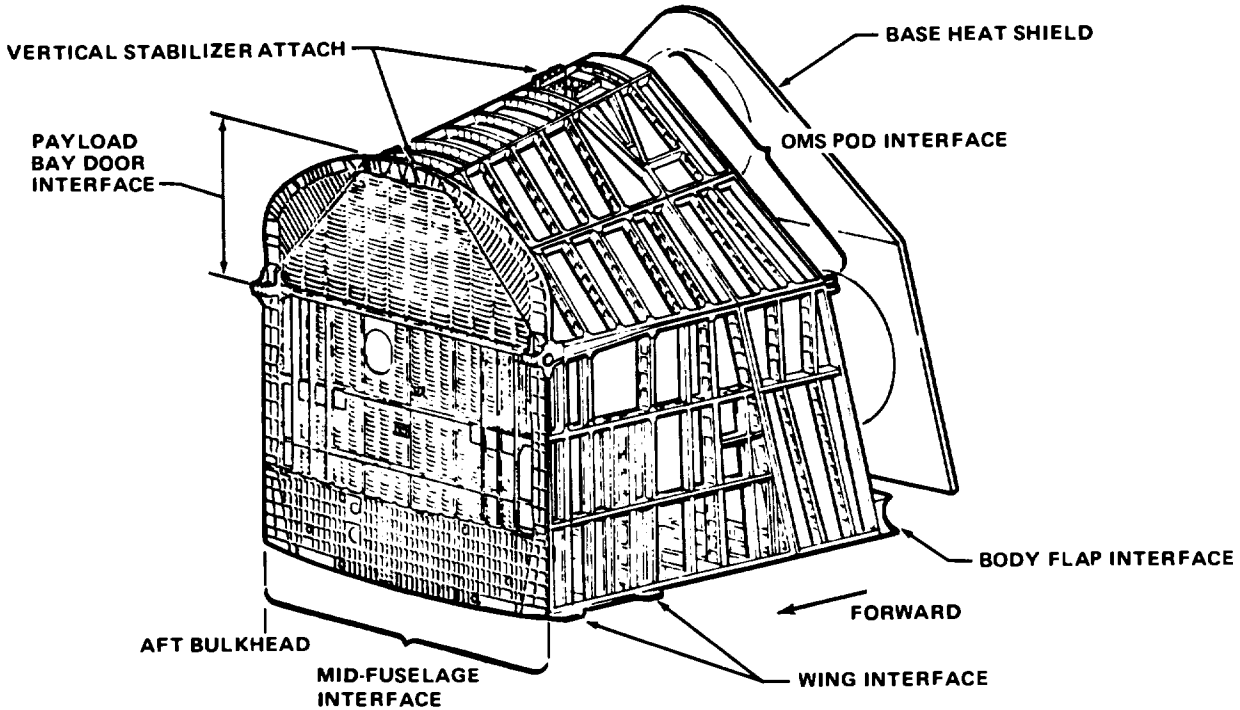

Figure 3-14.— Aft fuselage shell structure.

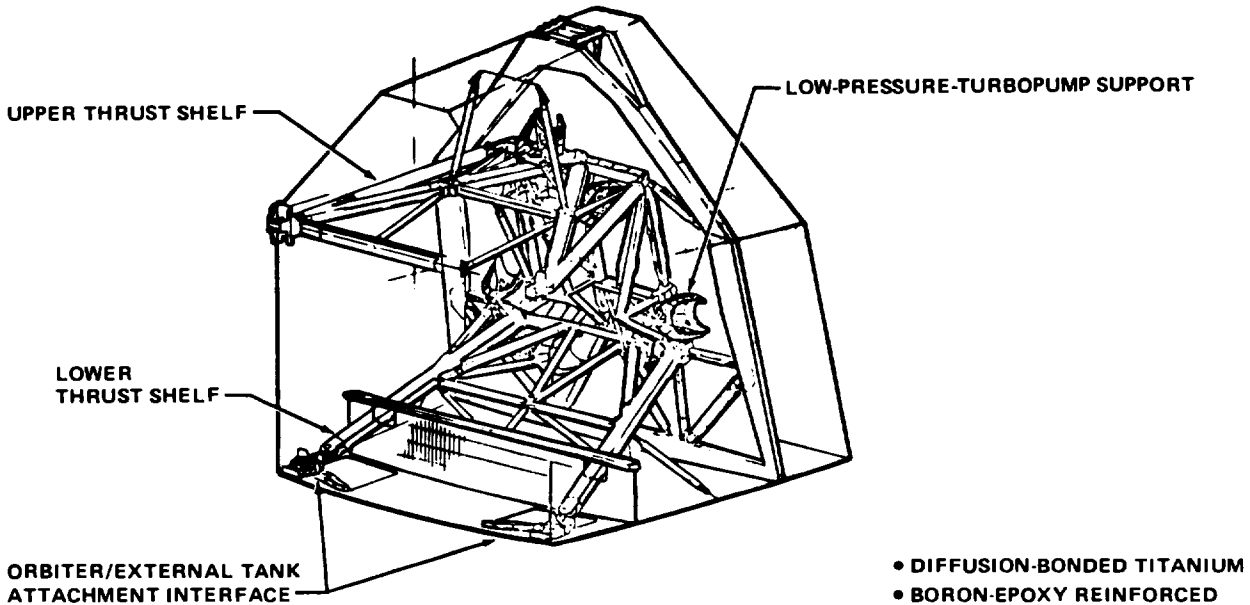

Figure 3-15.— Aft fuselage thrust structure.

fuselage, (3) structural support for the body flap, (4) structural housing around all internal systems for protection from the operational environment (pressure, thermal, and acoustics), and (5) controlled internal pressure venting during flight.

The internal thrust structure (figs. 3-15 and 3-16) carries loads from the Space Shuttle Main Engines. This structure includes the SSME load reaction truss structure, engine interface fittings, and the SSME actuator support structure.

The aft bulkhead separates the aft fuselage from the mid fuselage and is composed of machined and beaded sheet metal aluminum segments. The upper portion of the bulkhead attaches to the front spar of the vertical fin.

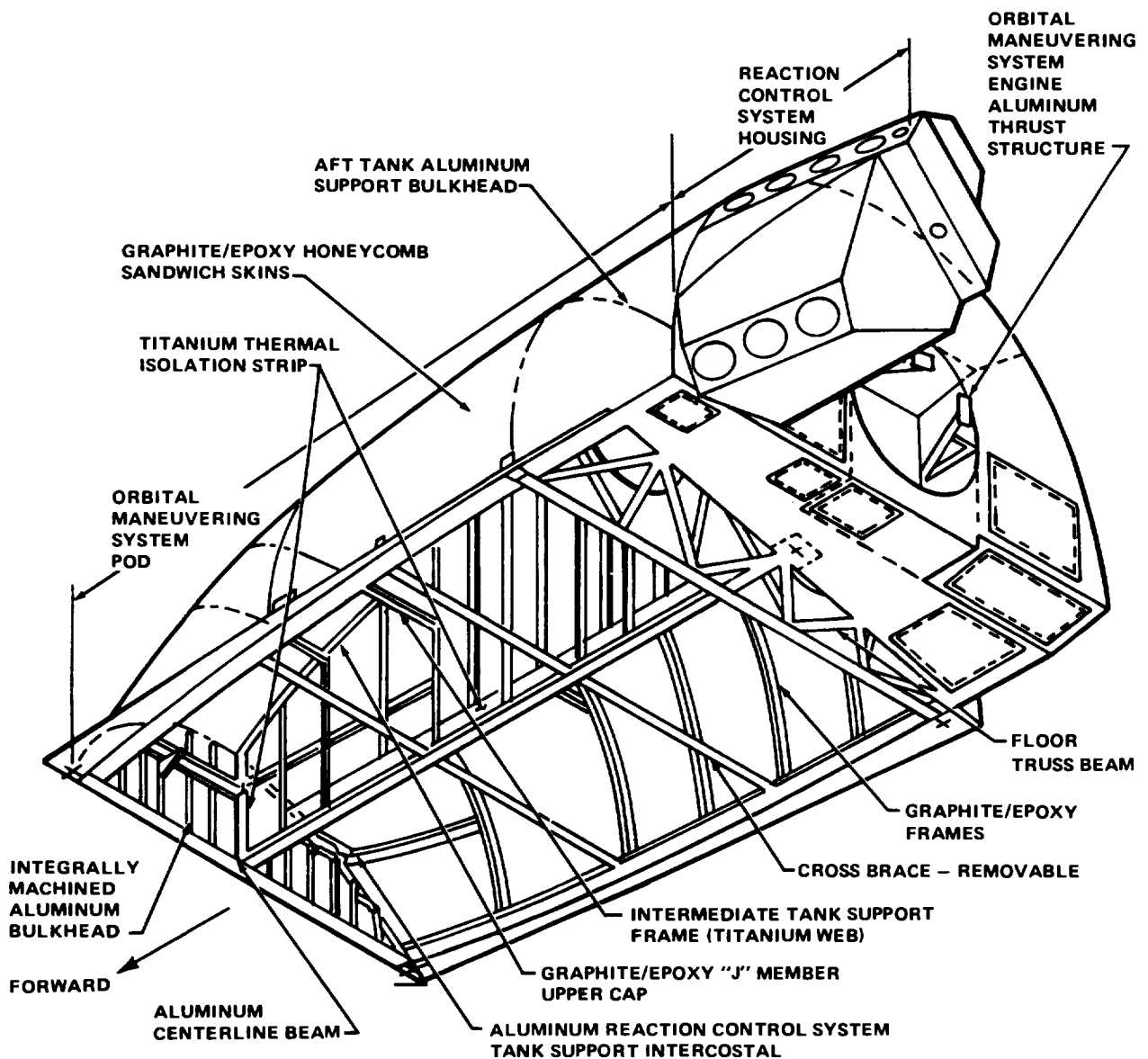

Figure 3-16.—Aft propulsion system thrust structure.

The body flap (fig. 3-17) is an aluminum structure consisting of ribs, spars, skin panels, and a trailing-edge assembly. The main upper and lower and the forward lower honeycomb skin panels are joined to the ribs, spars, and honeycomb trailing-edge assembly with structural fasteners. Addition of the removable upper forward honeycomb skin panels completes

the body-flap structure. This structure, which is covered with reusable surface insulation on its mold-line surfaces, is attached to the lower aft fuselage by four rotary actuators. With its aerodynamic and thermal seals, the body flap provides the Shuttle pitch trim control and thermally shields the main engines during reentry.

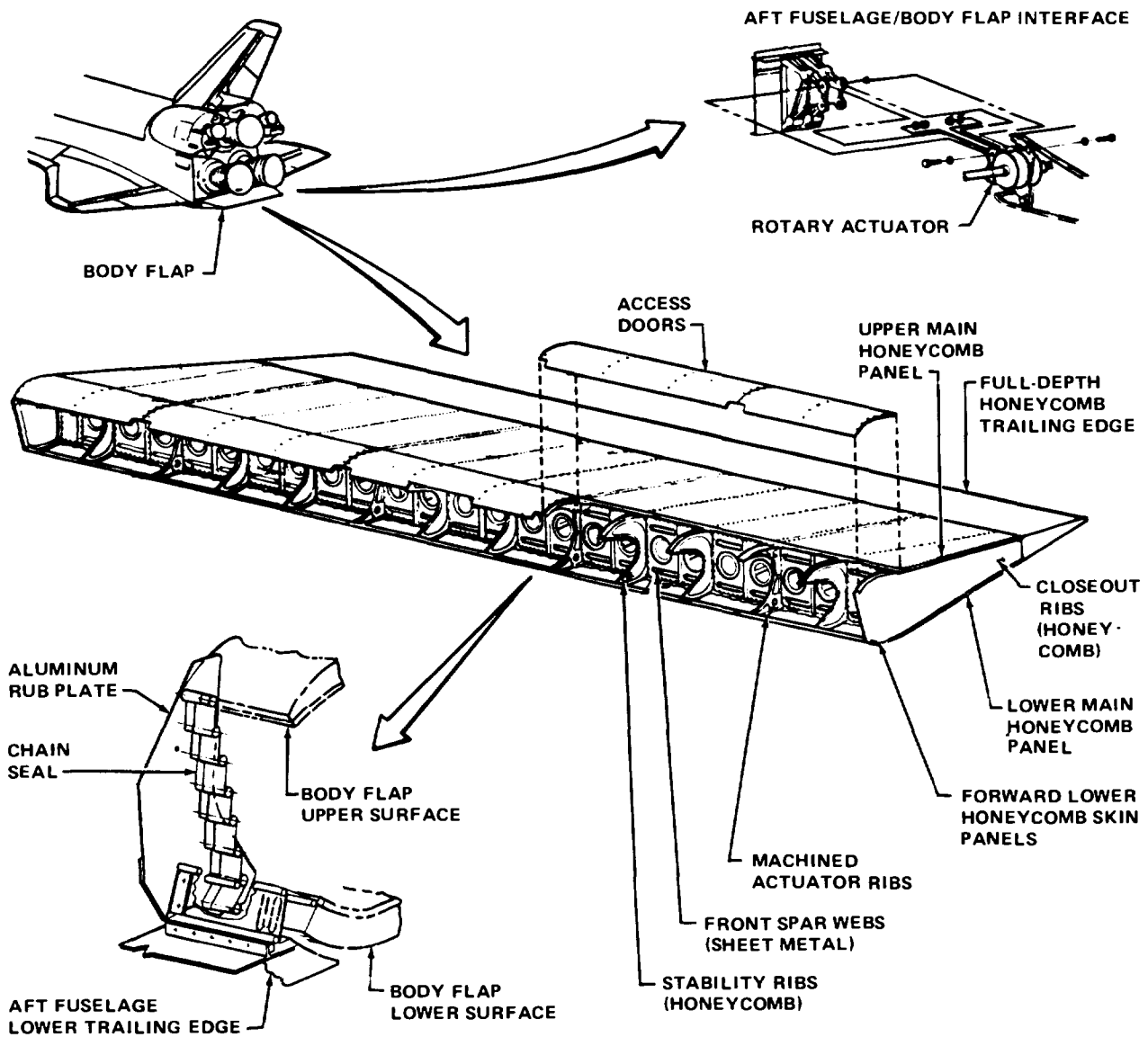

Figure 3-17.— Body flap.

WING

The wing (fig. 3-18) is the aerodynamic lifting surface that provides conventional lift and control for the Orbiter. The wing consists of the wing glove; the intermediate section, which includes the main landing gear well; the torque box, the forward spar for the mounting of the leading-edge structure thermal protection system; and the wing/elevon interface, the elevon seal panels, and the elevons.

The wing is constructed of conventional aluminum alloy with a multirib and spar arrangement with skin-stringer stiffened covers or honeycomb skin covers. Each wing is approximately 18.3 meters (60 feet) long at the fuselage intersection with a maximum thickness of 1.5 meters (5 feet).

The forward wing glove is an extension of the basic wing and aerodynamically blends the wing leading edge into the mid fuselage. The forward wing box is of a conventional design of aluminum multiribs and aluminum truss tubes with sheet-metal caps. The upper and lower wing skin panels are constructed of stiffened aluminum.

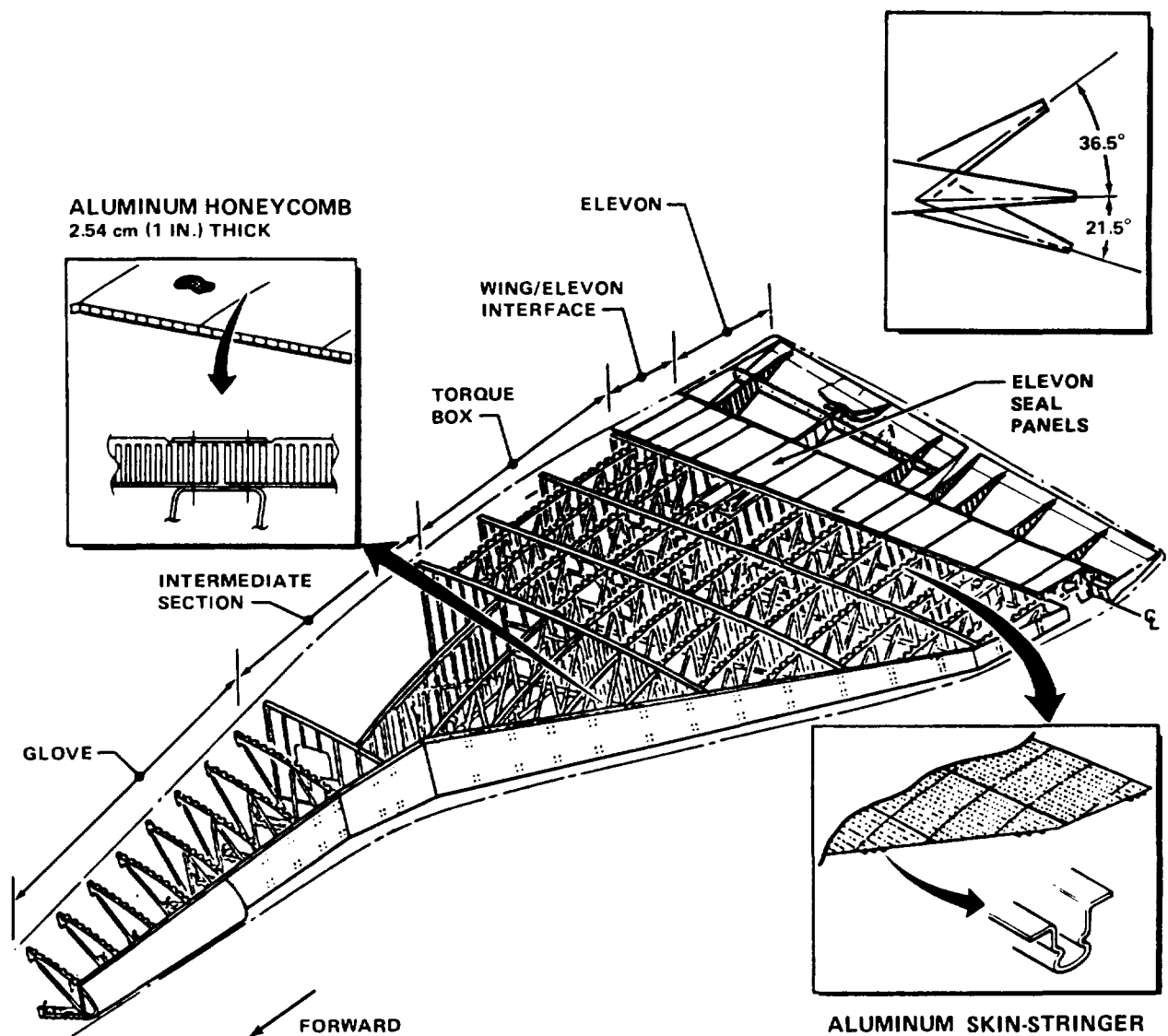

Figure 3-18.—Wing.

The intermediate wing section consists of the same conventional design of aluminum multiribs with aluminum truss tubes. The upper and lower skin covers are of aluminum honeycomb construction. A portion of the lower wing surface skin panel comprises the main landing gear door. The intermediate section houses the main landing gear compartment and carries a portion of the main landing gear loads.

The main landing gear door is constructed of aluminum with machined hinge beams and hinges. The recessed area in the door is for tire clearance.

The wing torque box area incorporates the conventional aluminum multirib truss arrangement with four spars. The four spars are constructed of corrugated aluminum to minimize thermal loads. The forward closeout beam is constructed of aluminum honeycomb and provides the attachment for the leading-edge structure thermal protection system. The rear spar provides the attachment interfaces for the elevons, hinged upper seal panels, and associated hydraulic and electrical system components. The upper and lower wing skin panels are constructed of aluminum stiffened skin.

The elevons provide flight control during atmospheric flight. The two-segment elevons are of conventional aluminum multirib and beam construction with aluminum honeycomb skins. Each segment is supported by three hinges. Flight control systems are attached along the forward extremity of the elevons. The upper leading edge of each elevon incorporates rub strips. The rub strips are of titanium/Inconel honeycomb construction and are not covered with the thermal protection system. The rub strips provide the sealing surface for the elevon seal panels.

A tension bolt splice along the upper surface and a shear splice along the lower surface are used to attach the wing to the fuselage.

VERTICAL STABILIZER

The vertical stabilizer (fig. 3-19) consists of a structural fin, the rudder/speed brake (the rudder splits in half for speed-brake control), and the systems for positioning the rudder/speed-brake control surface.

The vertical stabilizer structure consists of a torque box of aluminum integral stringers, web ribs, and two machined aluminum spars. The lower trailing-edge area of the fin that houses the

rudder/speed-brake power drive unit has aluminum honeycomb skins. The fin is attached to the forward bulkhead of the aft fuselage by 10 bolts.

The rudder/speed brakes consist of conventional aluminum ribs and spars with aluminum honeycomb skin panels and are attached to the vertical stabilizer by rotating hinges. The rudder/speed-brake assembly is divided into upper and lower sections. Each section splits to both sides of the fin in the speed-brake mode.

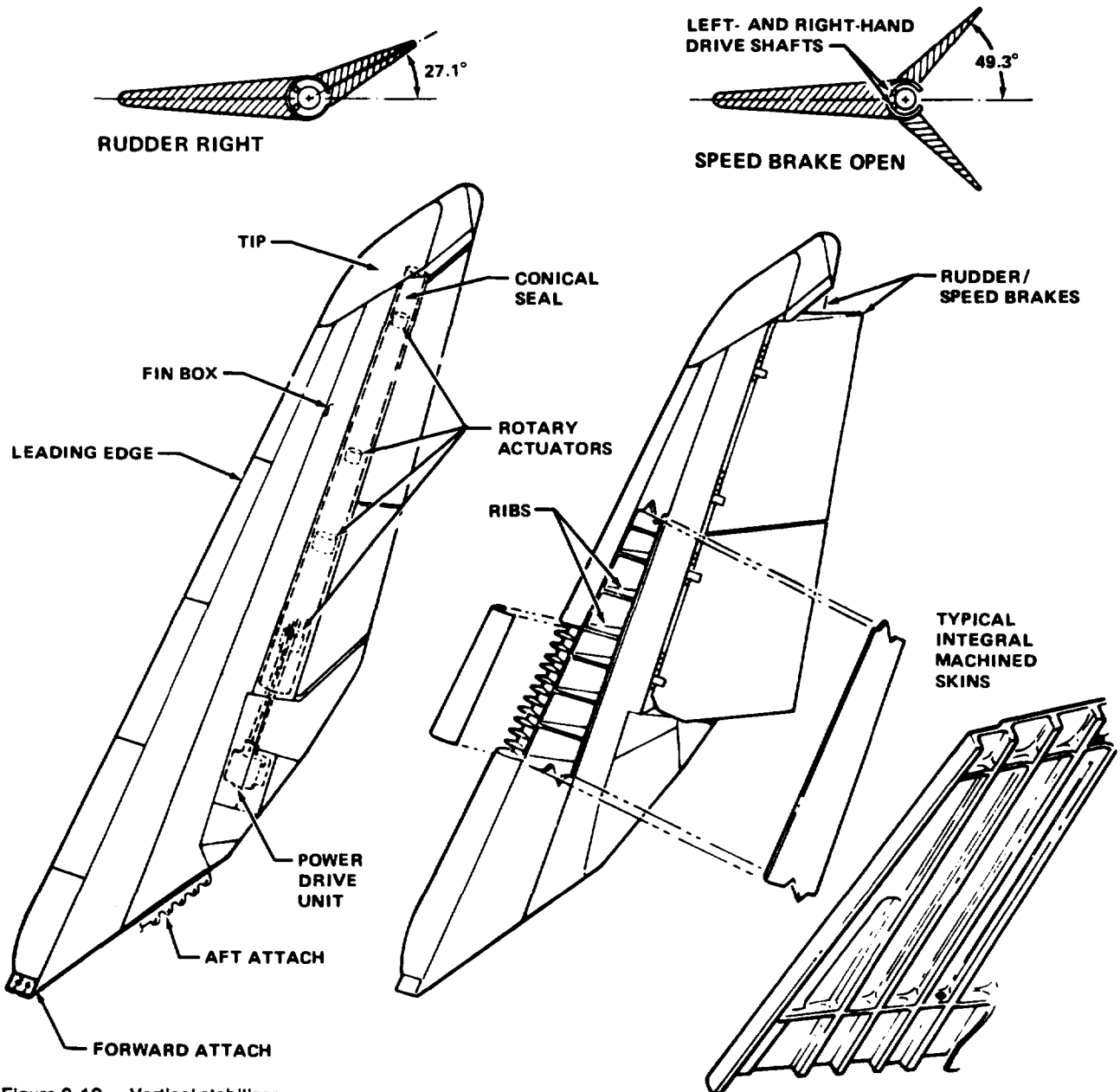

Figure 3-19.—Vertical stabilizer.

MECHANICAL SUBSYSTEMS

The Orbiter mechanical subsystems (fig. 3-20), with electrical and hydraulic actuators, operate the aerodynamic control surfaces, landing/deceleration system, payload bay doors, deployable radiators, and payload retention and payload handling subsystems. Orbiter/External Tank propellant disconnects and a variety of other mechanical and pyrotechnic devices comprise the balance of the mechanical subsystems.

Aerodynamic control surface movement is provided by hydraulically powered actuators that position the elevons and by hydraulically powered drive units that position the body flap and combination rudder/speed brake. Three redundant 20 684-kN/m² (3000-psi) systems supply the necessary hydraulic power. Elevon seal panels that provide an aerodynamic/thermal seal between the upper leading edges of the elevon and the upper wing surfaces are actuated by push/pull rod mechanisms attached directly to the elevons.

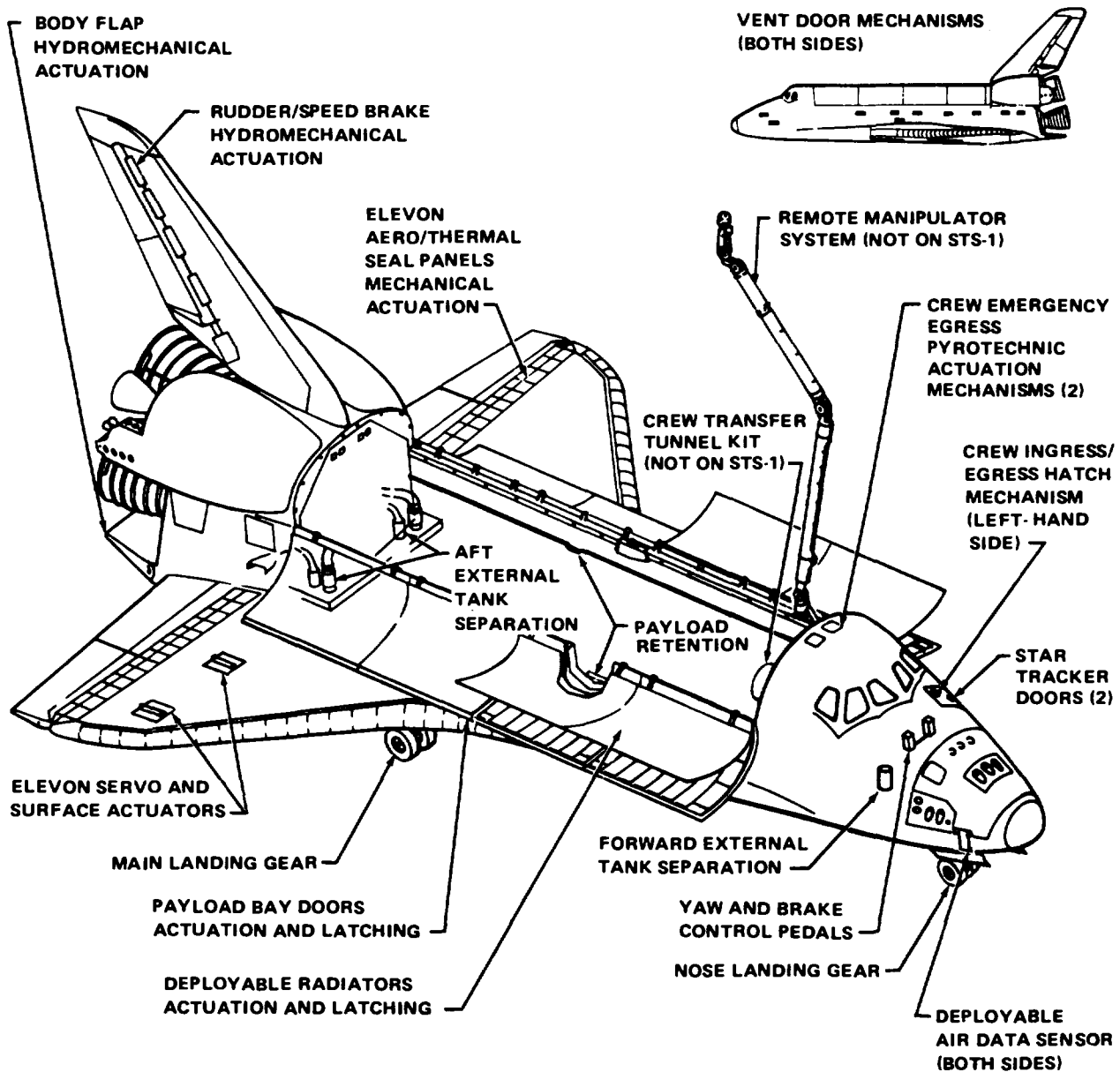

Figure 3-20.—Mechanical subsystems.

The fully retractable tricycle landing gear is designed to provide safe landings at speeds up to 409 km/h (254 mph). The shock struts are of conventional aircraft design with dual wheels/tires. Braking is accomplished by special lightweight carbon-lined beryllium brakes with antiskid protection.

The payload bay doors, deployable radiators, vent doors (forward fuselage, payload bay and wing, aft payload bay, and aft fuselage), star tracker doors, and separation-system closeout doors are operated by electromechanical actuators that must provide reliable performance after severe environmental exposure during ascent and entry and during orbital operations. The payload bay doors, when closed and latched, are part of the Orbiter structure and react to fuselage torsional loads.

The payload retention subsystem includes remotely controlled retention latches that hold down or release the payload items but do not transmit Orbiter stresses, such as bending, to the payload.

The payload-handling subsystem consists primarily of remotely controlled manipulator arms (one arm is normally installed; a second is optional) that can move the payloads in or out of the payload bay while in orbit.

Landing Gear

The Orbiter landing gears are arranged in a conventional tricycle configuration consisting of a nose landing gear and left and right main landing gears. The nose landing gear retracts forward and up into the forward fuselage. The main landing gears retract forward and up into the wings. Each landing gear is held in the retracted position by an uplock hook. The landing gears are extended by releasing the uplock hooks hydraulically, thus enabling the landing gear to free fall, assisted by springs and hydraulic pressure. The landing gear doors (two doors for the nose gear and one door for each main landing gear) open through a mechanical linkage attached to the landing gear. The landing gear will reach the fully extended position within a maximum of 10 seconds and are locked in the down position by spring-loaded bungees. The nose landing gear door opening and gear extension are also assisted by a pyrotechnic actuator to ensure gear deployment if adverse air load conditions occur.

The nose landing gear and the main landing gear contain a shock strut that is the primary source of shock attenuation during Orbiter landing impact. The shock struts are conventional "pneumatic" (gaseous nitrogen/hydraulic fluid) shock absorbers. A floating diaphragm within the shock strut separates the gaseous nitrogen dispersing throughout the hydraulic fluid in zero-g conditions. This separation is required to assure proper shock-strut performance at Orbiter touchdown.

For orbital missions, the landing gears are retracted, locked, and checked out before launch. Throughout the mission, until reentry is completed and preparations to land are initiated, the landing system remains essentially dormant. A landing gear "down" command removes the hydraulic isolation and initiates gear extension. After touchdown, brake application by the crew decelerates the Orbiter, with nose-wheel steering supplementing the directional control provided by aerodynamic forces on the rudder.

Both the nose gear and the wing-mounted main gears are equipped with dual wheels and both retract forward, thereby maintaining free-fall extension capabilities. Each of the four main wheels is equipped with a carbon-lined beryllium brake and fully modulated skid control system.

The nose landing gear consists of two wheel and tire assemblies. The nose gear is steerable when extended and there is weight on the nose gear. The nose-gear tires are 32 by 8.8, with a rated static load of 105 kilonewtons (23 700 pounds) and an inflation pressure of 2070 kN/m² (300 psi). The nose-gear tire life is five normal landings. Each main and nose gear tire is rated for 415 km/h (258 mph) with a maximum Orbiter load.

Separation and Pyrotechnic Subsystem

The External Tank and tank umbilical plates are securely attached to the External Tank support during ascent. (See section 2.) At tank separation, the umbilical plates—containing the propellant lines, electrical connectors, and vent lines—are released by energizing three solenoids. This release opens the hooks holding the umbilical plates together, and the plates are separated by a retract system. After the umbilical separation signal is received, the External Tank is separated from the Orbiter by simultaneously releasing the forward and aft structural ties.

Hatches

Side hatch.— The crew enters the crew compartment through the side hatch (fig. 3-21), which also serves as the primary emergency escape route. This hatch is on the left-hand side of the vehicle, forward of the wing, and is hinged to open outward. It is 101.6 centimeters (40 inches) in diameter and contains 28 latches, an actuator mechanism with provisions for interior/exterior operation, a viewport window-hatch coverplate, a ratchet assembly, an egress bar, and access doors.

The actuator mechanism is equipped with a handcrank on the crew module side for interior operation by the crew. A series of over-center latches driven by a series of links from the actuator are used to hold the hatch in the closed/sealed position. Two separate functions are required before the actuator will actuate the latches. The actuator handle must first be unlocked and then rotated counterclockwise to

unlock (clockwise to latch) the hatch. The actuator is capable of being driven manually either from within the crew module or from outside. The ratchet assembly is used to hold the hatch open while the Orbiter is on the pad.

For emergency egress, the crew will deploy the egress bar and descend. A hatch T-handle tool is provided for exterior ground operation and is used to operate the latch mechanism after removing the access door.

The hatch has a window 25.4 centimeters (10 inches) in diameter. The window cavity is covered by three panes (two inboard pressure panes and one outboard thermal pane).

Airlock hatch.— The airlock hatch will be used primarily for extravehicular operations but will also be used for stowage or retrieval of gear in the airlock and for transfer to and from the Spacelab or a docked vehicle. The airlock can be located either in the payload bay or in the mid

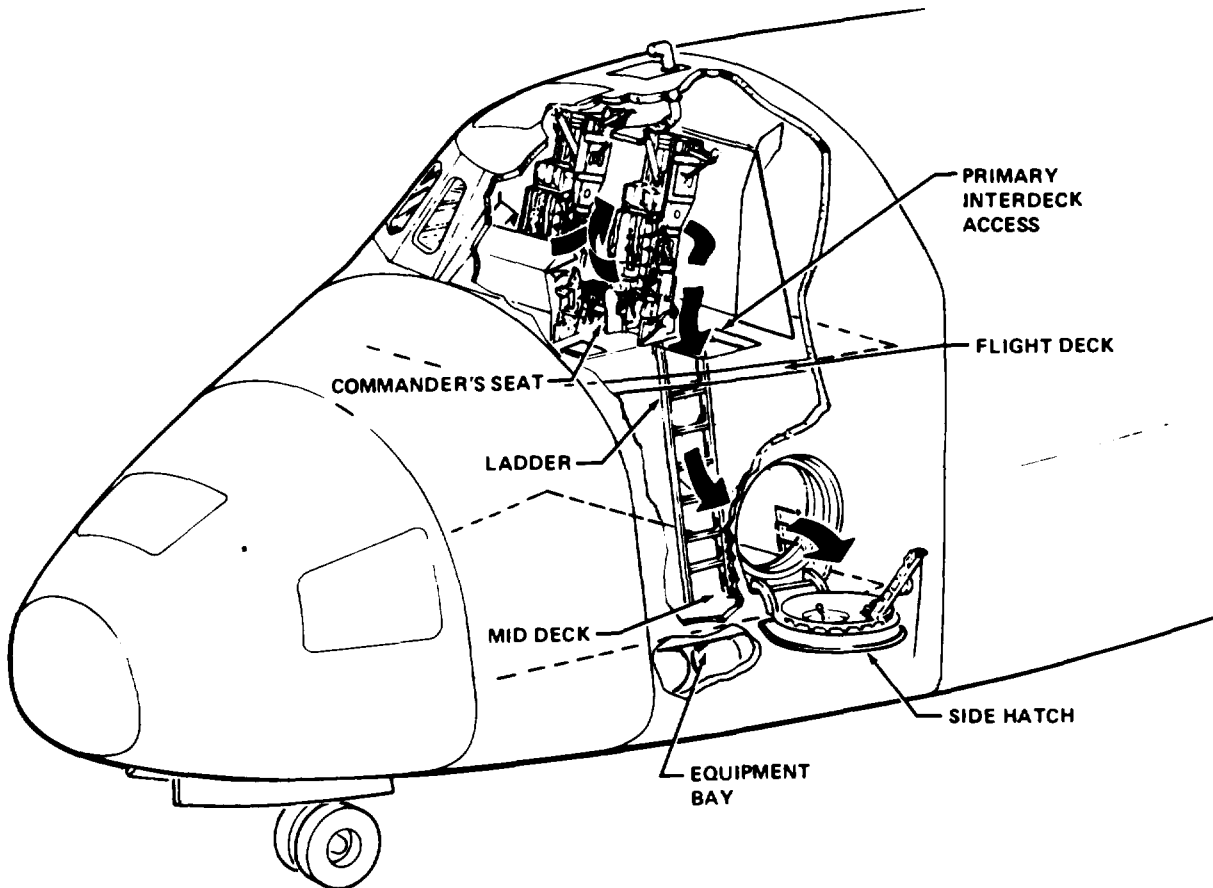

Figure 3-21.— Crew cabin ingress/egress.

deck of the Orbiter. The airlock has two universal hatches, except when it is located in the crew station mid deck. Here, the inner hatch will be a stowable hatch and the outer hatch will be a universal hatch (fig. 3-9).

The hatches are closed before flight and are opened for crew movement between the crew cabin, payload bay, and Spacelab. The inner airlock hatch is opened during the first day of activity and normally remains open for any contingency. The inner hatch will be closed before reentry.

Tunnel adapter hatch.— The tunnel adapter, when in use, is located on the payload-bay side of the manufacturing access panel (fig. 3-9). The adapter allows access to the airlock and the tunnel when both are in the payload bay at the same time. The tunnel connects the adapter and the Spacelab. When the tunnel adapter is onboard the Orbiter, the hatches will be closed for launch or reentry and opened for movement between the crew cabin and the tunnel or between the crew cabin and the airlock or docking module.

Docking module hatch.— The docking module hatches remain closed except for transfer to and from a docked vehicle or for extravehicular operations.

4. ORBITER SYSTEMS

Briefly . . .

The propulsion systems of the Space Shuttle consist of the three main engines, the Solid Rocket Boosters, and the External Tank (see section 2) and the orbital maneuvering and reaction control systems. The main engines and the boosters provide the thrust for the launch phase of the mission. The orbital maneuvering system thrusts the Orbiter into orbit and provides the thrust to transfer from one orbit to another, to rendezvous with another spacecraft, and to deorbit. The reaction control system provides the power needed to change speed in orbit and to change the attitude (pitch, roll, or yaw) of the Orbiter when the vehicle is above 21 000 meters (70 000 feet).

ORBITAL MANEUVERING SYSTEM ①

Two engines

Thrust level = 26 688 newtons (6000 pounds)
vacuum each

Propellants

Monomethyl hydrazine (fuel) and
nitrogen tetroxide (oxidizer)

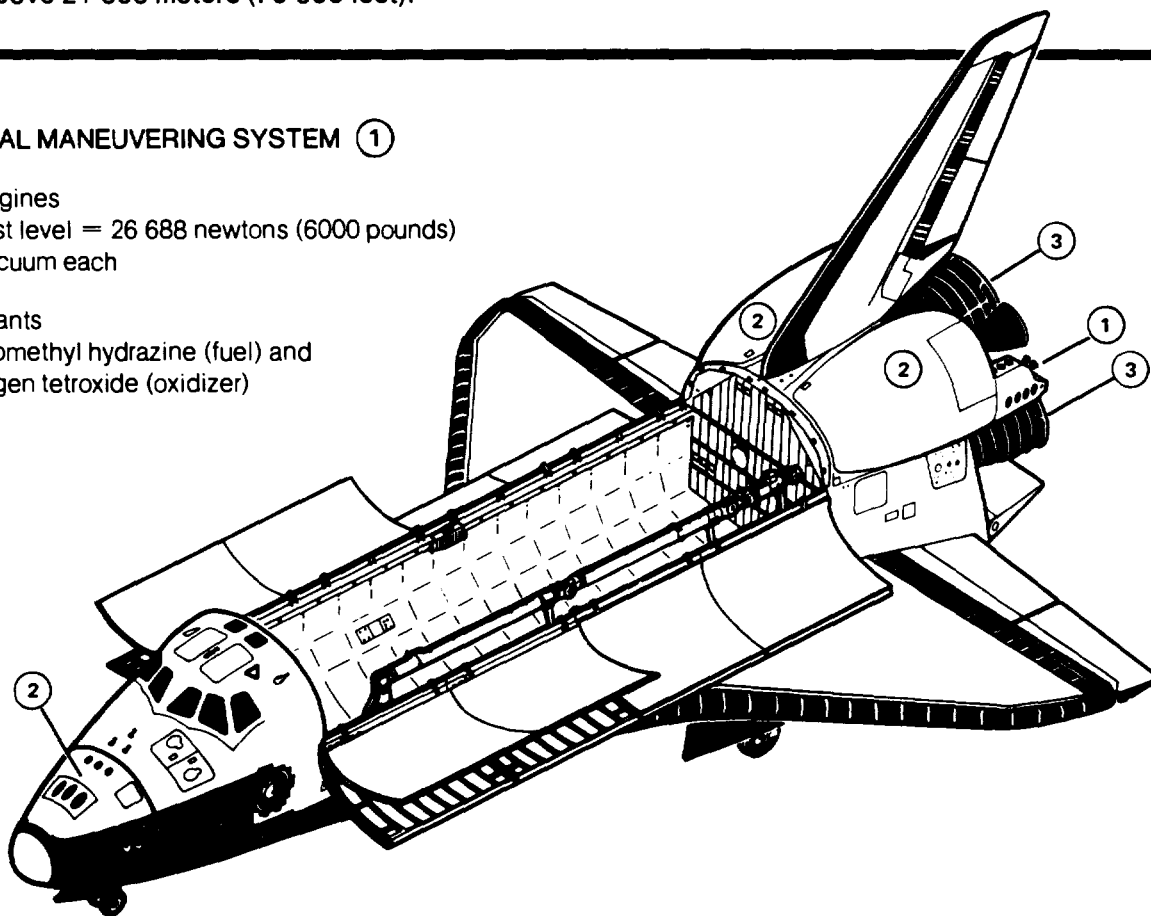

REACTION CONTROL SYSTEM ②

One forward module, two aft pods

38 primary thrusters (14 forward, 12 per aft pod)
Thrust level = 3870 newtons (870 pounds)

Six vernier thrusters (two forward, four aft)
Thrust level = 111.2 newtons (25 pounds)

Propellants

Monomethyl hydrazine (fuel) and
nitrogen tetroxide (oxidizer)

MAIN PROPULSION (See section 2) ③

Three engines

Thrust level = 2 100 000 newtons (470 000 pounds)
vacuum each

Propellants

Liquid hydrogen (fuel) and
liquid oxygen (oxidizer)

4. ORBITER SYSTEMS

Propulsion

ORBITAL MANEUVERING SYSTEM

Two orbital maneuvering engines, located in external pods on each side of the aft fuselage, provide thrust for orbit insertion, orbit change, orbit transfer, rendezvous, and deorbit. The maneuvering engines can provide a velocity change of 305 m/s (1000 ft/s) when the Orbiter carries a payload of 29 500 kilograms (65 000

pounds.) A portion of this velocity change capacity is used during the final ascent to orbit. The 10 900 kilograms (24 000 pounds) of usable propellant is contained in two pods, one on each side of the aft fuselage. Each pod contains a high-pressure helium storage bottle, the tank pressurization regulators and controls, a fuel tank, an oxidizer tank, and a pressure-fed regeneratively cooled rocket engine (fig. 4-1).

Provisions are also included for up to three sets of auxiliary tanks (orbital maneuvering system (OMS) kits), each providing an additional 150 m/s (500 ft/s) to achieve an overall capability of 755 m/s (2500 ft/s). The OMS kits are located in the payload bay and use the same type propellant tanks, helium bottles, and pressurization system components as the pods.

Each engine develops a vacuum thrust of 27 kilonewtons (6000 pounds) using a hypergolic propellant combination of nitrogen tetroxide (N_2O_4) and monomethyl hydrazine (MMH). These propellants are burned at a nominal oxidizer-to-fuel mixture ratio of 1.65 and a chamber pressure of 860 kN/m² (125 psia).

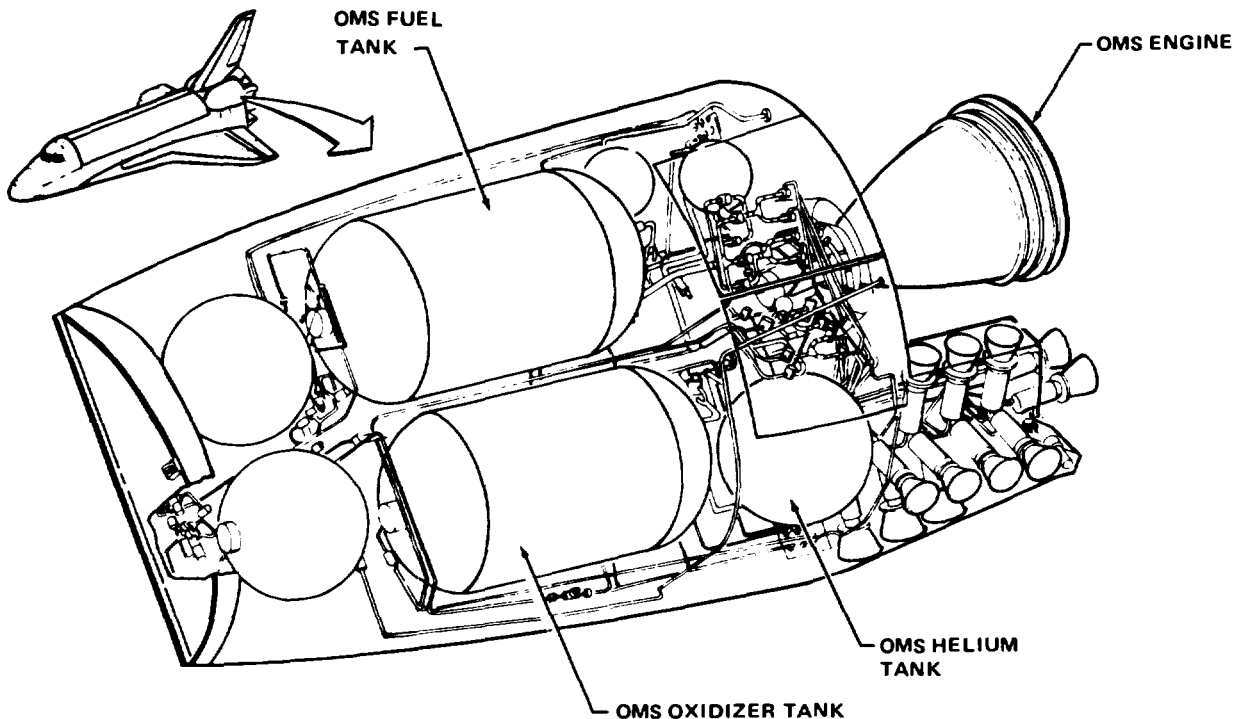

Figure 4-1.— Orbital maneuvering system.

ORIGINAL PAGE IS
OF POOR QUALITY.

The engine is designed for 100 missions with a service life of 10 years and is capable of sustaining 1000 starts and 15 hours of cumulative firing time. Each engine is 196 centimeters (77 inches) long and weighs 118 kilograms (260 pounds).

The engine is gimballed by pitch and yaw electromechanical actuators attached to the vehicle structure at the forward end of the combustion chamber. The controller for the actuators is mounted in the pod structure. The major components of the engine are the platelet injector; the fuel regeneratively cooled combustion chamber; the radiation-cooled nozzle extension, an 80-percent bell that extends from an area ratio of 6:1 where it attaches to the chamber to an expansion ratio of 55:1 at the exit plane; a series-redundant ball-type bipropellant valve, which is opened by regulated nitrogen gas supplied by a pneumatic actuation assembly; the thrust mount and gimbal assembly; and the propellant lines.

REACTION CONTROL SYSTEM

The Orbiter reaction control system (RCS) (fig. 4-2) provides the thrust for velocity changes along the axis of the Orbiter and attitude control (pitch, yaw, and roll) during the orbit insertion, onorbit, and reentry phases of flight. It has 38 bipropellant primary thrusters and 6 vernier thrusters.

The reaction control system is grouped in three modules, one in the Orbiter nose and one in each aft fuselage pod. Each module is independent and contains its own pressurization system and propellant tanks. The forward module contains 14 primary thrusters and 2 vernier thrusters; each aft module contains 12 primary and 2 vernier thrusters. The multiple primary thrusters pointing in each direction provide redundancy for mission safety.

The control system propellants are nitrogen tetroxide as the oxidizer and monomethyl hydrazine as the fuel. The design mixture ratio of 1.65 (oxidizer weight to fuel weight) permits the use of identical propellant tanks for both fuel and oxidizer. The propellant tank internal screen configuration varies from the forward module to the aft pod because of the variation in operational requirements; i.e., the aft

RCS must operate during the high-g phase of entry while the forward RCS is inactive during this period. All three modules are used for External Tank separation, orbit insertion, and orbital maneuvers. The propellant capacity of the tanks in each module is 422 kilograms (930 pounds) of MMH and 675 kilograms (1488 pounds) of N_2O_4 . A system of heaters is used to maintain temperatures of the engines, propellant lines, and other components within operational limits.

The usable propellant quantity for each location is 621 kilograms (1369 pounds) of N_2O_4 and 388 kilograms (856 pounds) of MMH in the nose section module and 1318 kilograms (2905 pounds) of N_2O_4 and 823 kilograms (1815 pounds) of MMH in both aft section modules. An interconnect between the OMS and RCS in the aft pods permits the use of OMS propellants by the RCS for orbital maneuvers. In addition, the interconnect can be used for crossfeeding RCS propellants between the right and left pods.

The propellants are sprayed under controlled pressure by the injector into the combustion chamber where they combine hypergolically to produce hot gases. The gases are then expanded and accelerated through the nozzle to produce thrust.

The primary thrusters are used for normal translation and attitude control. The vernier thrusters are used for fine attitude control and payload pointing where contamination or plume impingement are important considerations. The vernier thrusters, which have no redundancy, are oriented to avoid plume vectors toward the payload bay.

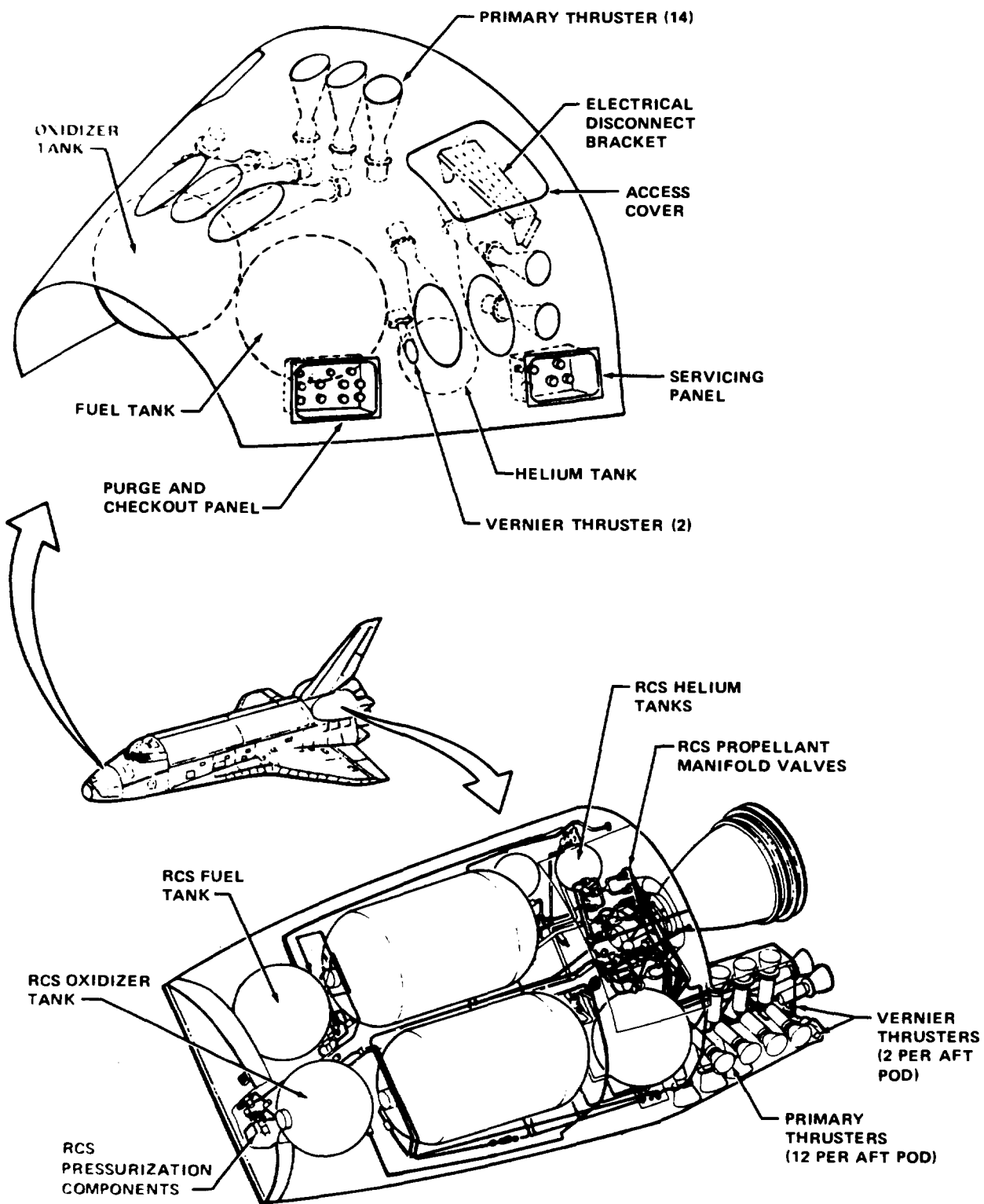
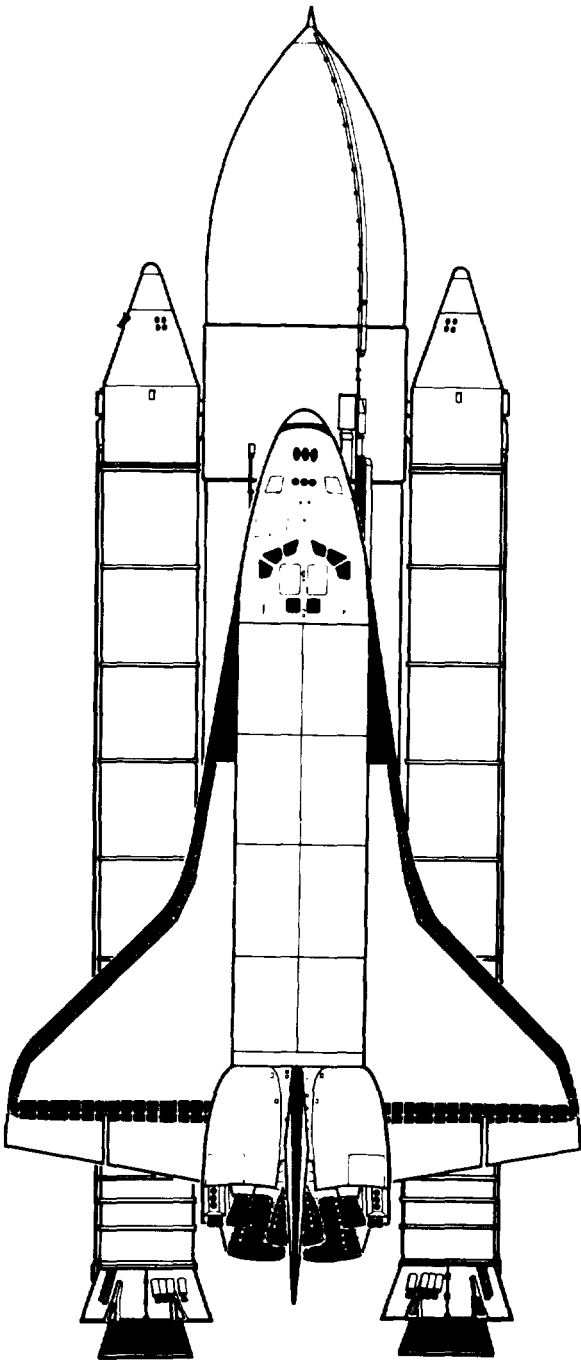

Figure 4-2 — Reaction control system.

4. ORBITER SYSTEMS



Power Generation

ELECTRICAL POWER	4-11
Power Reactant Storage and Distribution	4-11
Fuel Cell System	4-11
Electrical Control Unit	4-13
HYDRAULIC POWER	4-14

PRECEDING PAGE BLANK NOT FILMED

Briefly...

Four hydrogen-oxygen fuel cells supply all the electrical power for the Orbiter during all mission phases and three hydrazine-fueled turbines drive pumps to provide hydraulic pressure.

ELECTRICAL SYSTEM

- POWER GENERATION SYSTEM
- POWER REACTANT STORAGE AND DISTRIBUTION SYSTEM

FUEL CELL POWERPLANT
2-KILOWATTS MINIMUM,
7-KILOWATTS CONTINUOUS,
12-KILOWATTS PEAK PER FCP
15-MINUTE DURATION ONCE
EACH 3 HOURS

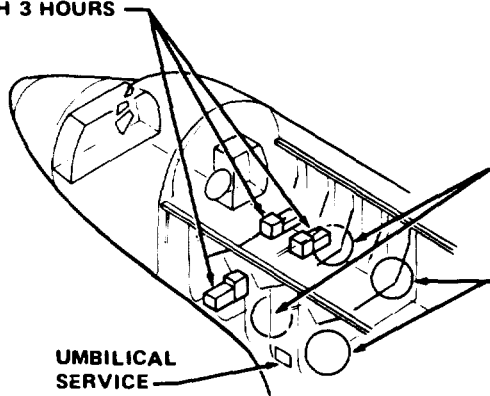

FUEL CELL POWERPLANT SYSTEM

14-kilowatt continuous/24-kilowatt peak
27.5 to 32.5 volts direct current

REACTANT STORAGE

5508 megajoules (1530 kilowatt-hours)
mission energy
950 megajoules (264 kilowatt-hours)
abort/survival energy
51 kilograms (112 pounds) oxygen for ECLSS
42 kilograms (92 pounds)
hydrogen per tank
354 kilograms (781 pounds)
oxygen per tank

TOTAL
LOADED
QUANTITY

OXYGEN TANKS
0.035-CUBIC-METER (12.3-CUBIC-FOOT) CAPACITY
7240 kN/m² (1050 PSIA) MAXIMUM PRESSURE

HYDROGEN TANKS
0.665-CUBIC-METER (23.5-CUBIC-FOOT) CAPACITY
2310 kN/m² (335 PSIA) MAXIMUM PRESSURE

HYDRAULIC SYSTEM

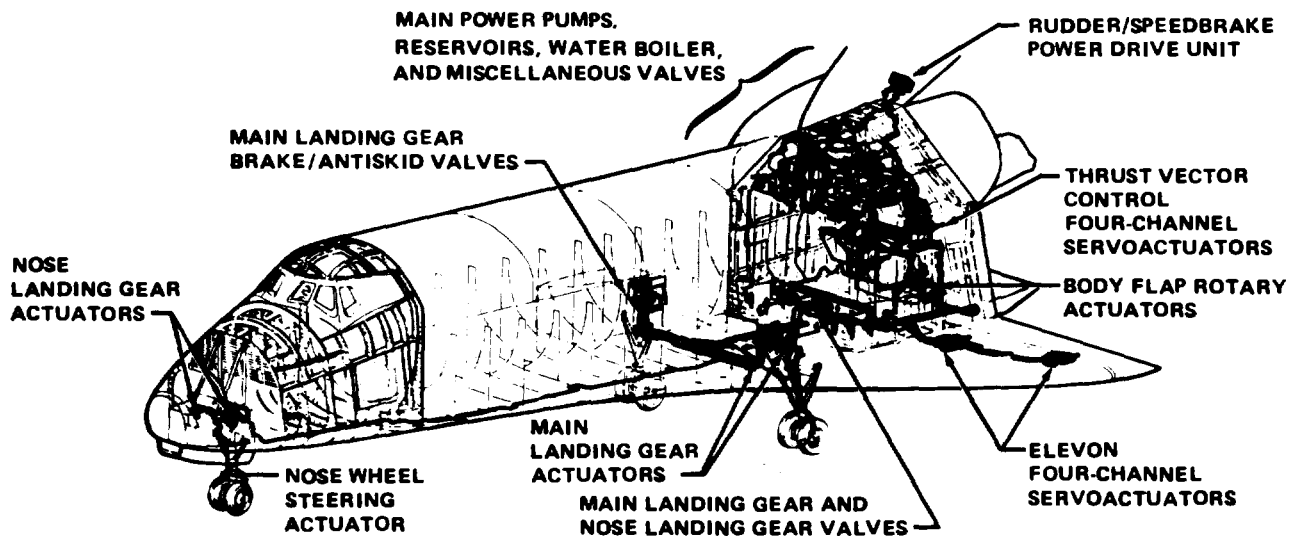

Power Generation

The Orbiter has one system to supply electrical power and another to supply hydraulic power. Electrical power is generated by three fuel cells that use cryogenically stored hydrogen and oxygen reactants. Hydraulic power is derived from three independent hydraulic pumps, each driven by its own hydrazine-fueled auxiliary power unit and cooled by its own boiler.

ELECTRICAL POWER

Power Reactant Storage and Distribution

The power reactant storage and distribution (PRSD) system contains the cryogenic oxygen and hydrogen reactants that are supplied to the fuel cells and the oxygen that is supplied to the environmental control and life support system (ECLSS). The oxygen and hydrogen are stored in double-walled vacuum-jacketed Dewar-type spherical tanks in a supercritical condition (97 K (−176°C or −285°F) for oxygen and 22 K (−251°C or −420°F) for hydrogen). In this supercritical condition, the hydrogen or oxygen takes the form of a cold, dense, high-pressure gas that can be expelled, gaged (quantity measured), and controlled under zero-g conditions. Automatic controls, activated by pressure, energize tank heaters and thus add heat to the reactants to maintain pressure during depletion. Each tank has relief valves to prevent overpressurization from abnormal operating conditions. Redundancy is provided by having two components for each major function or by providing manual override of the automatic controls.

The distribution system consists of filters, check valves, and shutoff valves. The valves and plumbing are arranged so that any tank can be used to supply any subsystem or any tank can be isolated in case of a failure. In addition, the distribution system can be isolated into two halves by using valves provided for that purpose so that a distribution system failure can be tolerated.

Each oxygen tank can store 354 kilograms (781 pounds) of oxygen and each hydrogen tank can store 42 kilograms (92 pounds) of hydrogen. The hydrogen tank is 115.6 centimeters (45.5 inches) in diameter and the oxygen tank is 93.5 centimeters (36.8 inches) in diameter. The basic system consists of four oxygen and four hydrogen tanks with additional tanks available to take care of added requirements. The oxygen and hydrogen tanks are shown in figure 4-3.

Fuel Cell System

The fuel cell system produces the electrical power required by the Orbiter during all mission phases. The fuel cell system is composed of three units located in the mid body. Each fuel cell powerplant is composed of a single stack of cells divided electrically into parallel connected substacks of 32 cells each.

Electrical power is produced by the chemical reaction of hydrogen and oxygen, which are supplied continuously as needed to meet output requirements. A byproduct of this reaction is drinkable water needed for the crew. Each fuel cell is connected to one of three independent electrical buses.

During peak and average power loads, all three fuel cells and buses are used; during minimum power loads, only two fuel cells are used but they are interconnected to the three buses. The third fuel cell is placed on standby but can be reconnected instantly to support higher loads. Alternately, the third fuel cell is shut down under the condition of a 278-K (4.4°C or 40°F) minimum-temperature environment and can be reconnected within 15 minutes to support higher loads.

The electrical power requirements of a payload will vary throughout a mission. During the 10-minute launch-to-orbit phase and the 30-minute deorbit-to-landing phase when most of the experiment hardware is in a standby mode or completely turned off, 1000 watts average to 1500 watts peak are available from the Orbiter. During payload equipment operation in orbit, the capability exists to provide as much as 7000 watts maximum average to 12 000 watts peak for major energy-consuming payloads. For a 7-day mission payload, 180 megajoules (50 kilowatt-hours) of electrical energy are available. Mission kits containing consumables for 3060 megajoules (850 kilowatt-hours) each are also available.

The Space Shuttle fuel cells will be serviced between flights and reflown until each has accumulated 5000 hours of on-line service. Although the Shuttle fuel cells are no larger than those used during the Apollo Program, each has six times the output of the Apollo fuel cells.

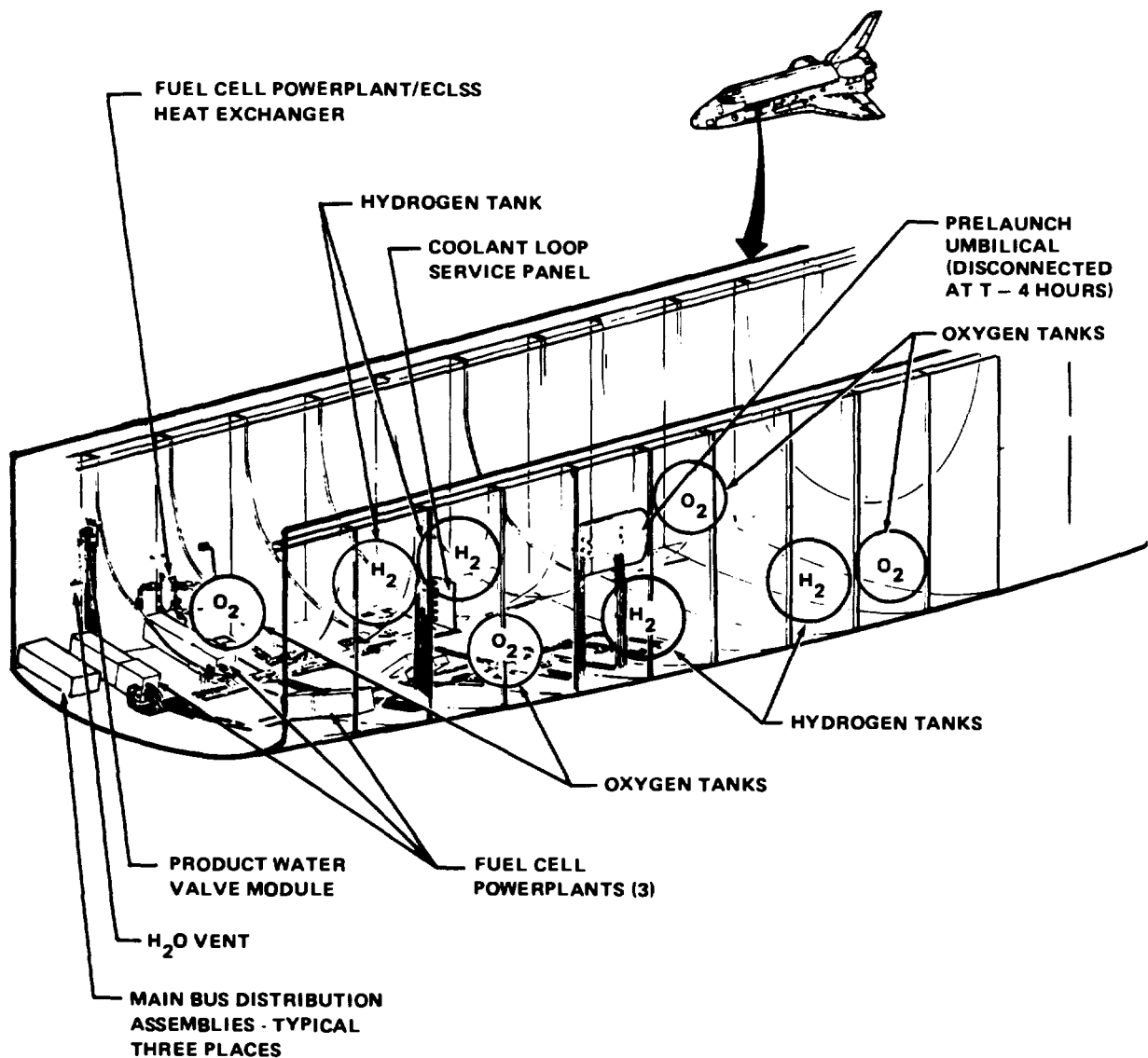

Figure 4-3.—Electrical power system.

The Shuttle powerplant is a single stack of 64 cells divided electrically into two parallel connected substacks of 32 cells each. An accessory section containing components for reactant management, thermal control, water removal, electrical control, and monitoring is located at one end of the stack. The entire accessory section can be separated from the cell stack for maintenance. The interface panel, which is part of the accessory section, provides (1) fluid connections for hydrogen and oxygen supply and purge, water discharge, and coolant in and out, and (2) electrical connectors for power out, control instrumentation, power input, and preflight verification data. A complete Orbiter fuel cell powerplant measures 35.6 by 43.2 by 101.6 centimeters (14 by 17 by 40 inches) and weighs approximately 92 kilograms (202 pounds).

Each cell consists of an anode, a cathode, and a matrix containing the catalyst of potassium hydroxide (KOH). Magnesium separator plates provide rigidity, electron transfer paths (the means to distribute hydrogen and oxygen to the cells), and water and waste heat removal. Electrons produced by the reaction flow through the separator plates to the power takeoff point where the power feeds into the electrical system.

Electrical Control Unit

The electrical control unit (ECU) consists of a start/stop control and the isolation and control relays. The heater group is composed of the end cell and the sustaining and startup heaters and their control switches. The pump motors are the only components that draw significant power during normal operations. The ECU starts and stops the powerplant independent of any outside support equipment. When the operator starts the system, the hydrogen pump separator, the coolant pump, and the heaters are activated; when the fuel cell stack reaches operating temperature, the startup heater cycles off automatically. A coolant pressure interlock prevents overheating the coolant.

Power for the startup and sustaining heaters comes from the fuel cell powerplant dc power bus. Each heater is controlled by a separate switch. The sustaining heaters keep fuel cell stack temperatures at the proper level during sea level operations at low-power settings, and the end-cell heaters keep end-cell temperatures near those of the rest of the stack.

Power for driving the hydrogen and oxygen valves comes from the vehicle-essential dc control bus, and pump motors draw 115-volt 400-hertz three-phase ac power from the Orbiter ac bus.

HYDRAULIC POWER

The Orbiter flight control system actuators, main engine thrust-vector-control actuators, and utility actuators are powered by the three auxiliary power units (APU's). This differs from most commercial and military aircraft in that these applications typically use main engine shaft power to drive the hydraulic pump. The Shuttle units and hydraulic system (fig. 4-4) are sized so that any two of the three systems can perform all flight control functions.

The auxiliary power units are started before launch and used for engine control during boost. The systems are shut down during orbital operation; they are restarted 5 minutes before the deorbit burn and continue to operate until approximately 5 minutes after landing. The circulation pumps are operated after landing to circulate the hydraulic fluid through the water heat exchangers to dissipate the postlanding heat soakback.

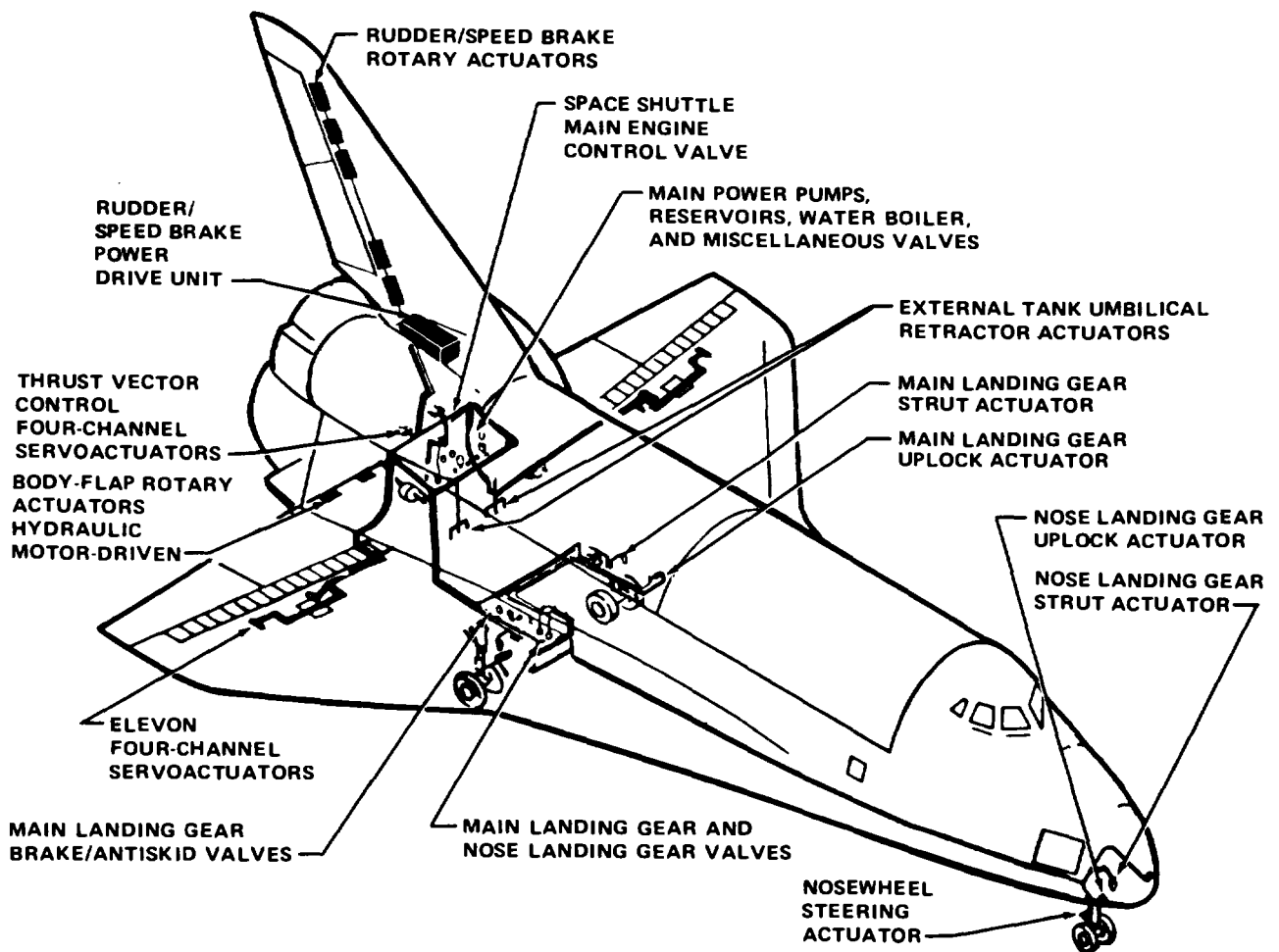

Figure 4-4.—Orbiter hydraulic system.

The main pumps—the heart of the hydraulic system—are variable-displacement pressure-compensated units capable of 238-liters/min (63-gal/min) output at the minimum power engine speed. A depressurization valve on the pump reduces the output pressure, and therefore the input torque requirement, during bootstrap startup of the power units. The hydraulic fluid is supplied to the appropriate subsystems at a nominal 20 684 kN/m² (3000 psig) through thermally insulated titanium lines. Suction pressure is provided by a bootstrap reservoir pressurized by the main pump during APU operation and by a gaseous nitrogen accumulator during off times.

Cooling for the hydraulic fluid and the APU lubrication oil is provided by a water-spray heat exchanger located in the return line of each system. Fluid circulation for thermal control during onorbit coldsoak is provided by an electric-motor-driven circulation pump in each hydraulic system.

The auxiliary power unit system (fig. 4-5), consisting of three independent 103-kilowatt (138-horsepower) turbine engines, converts the chemical energy of liquid hydrazine into mechanical shaft power which drives hydraulic pumps that provide power to operate aerosurfaces, main engine thrust-vector-control and engine valves, landing gear, and other system actuators. The APU is unique in that it is not an auxiliary power system but actually drives the hydraulic system pumps. Each APU weighs 39 kilograms (85 pounds).

The auxiliary power system provides primary hydraulic power during the launch and entry phases of the mission. The turbine engines are started several minutes before launch and are shut down several minutes after termination of thrust from the Orbiter main engines. All three units are required to be operating in order to maintain thrust vector control for the three main engines because the vector control system for each main engine is connected to a single power unit. If shaft power from a power unit is prematurely interrupted during launch, it may become necessary to abort the normal launch cycle and either return to the launch site or seek a lower Earth orbit and return to a landing site near the end of the first orbit.

Conversely, the entry functions that require APU power are arranged such that power can be supplied from more than one unit. Therefore, a satisfactory entry can be accomplished with only two of the three APU's operating. This is called "fail-safe" redundancy.

Approximately 134 kilograms (295 pounds) of hydrazine is stored in a fuel tank in each unit and is pressurized with helium to no more than 2550 kN/m² (370 psig), providing 91 minutes of APU operation. The hydrazine pressure is boosted to approximately 10 342 kN/m² (1500 psi) by the APU fuel pump, which is driven from the unit's gearbox. The high-pressure hydrazine is routed from the fuel pump outlet to the gas generator valve module, which controls the flow of hydrazine to the gas generator. When the valves in the gas generator valve module are open, hydrazine flows into the gas generator. The APU controller automatically cycles these valves to maintain the proper turbine speed of 72 000 rpm.

The gas generator contains a bed of granular catalyst that decomposes the hydrazine into a hot gas of approximately 1 200 K (927°C or 1700°F) and 6900 to 8300 kN/m² (1000 to 1 200 psi). These hot gases are expanded to a lower pressure, accelerated to a high velocity, and directed at the turbine blades by a nozzle.

The turbine consists of a single impulse wheel with a top speed of 555 m/s (1821 ft/s). The hot gas exits the first-stage nozzle and is passed through the blades of the rotor. It is then collected in a duct, turned and directed through 12 second-stage nozzles, and passed through the rotor in a direction opposite to the first-stage flow. The gas, now at a much lower temperature because of its expansion to slightly over atmospheric pressure, passes into the exhaust housing. These cooler exhaust gases of approximately 755 to 810 K (482° to 538°C or 900° to 1000°F) then pass over the gas generator and cool the outer metal surfaces before being routed through the exhaust duct to the overboard vent.

The momentum of the high-velocity gas is transferred to the blades of the turbine wheel as the direction of the gas is changed during its passages through the blades. The torque applied to the blades by the high-velocity gas is transferred to the gearbox through the turbine shaft.

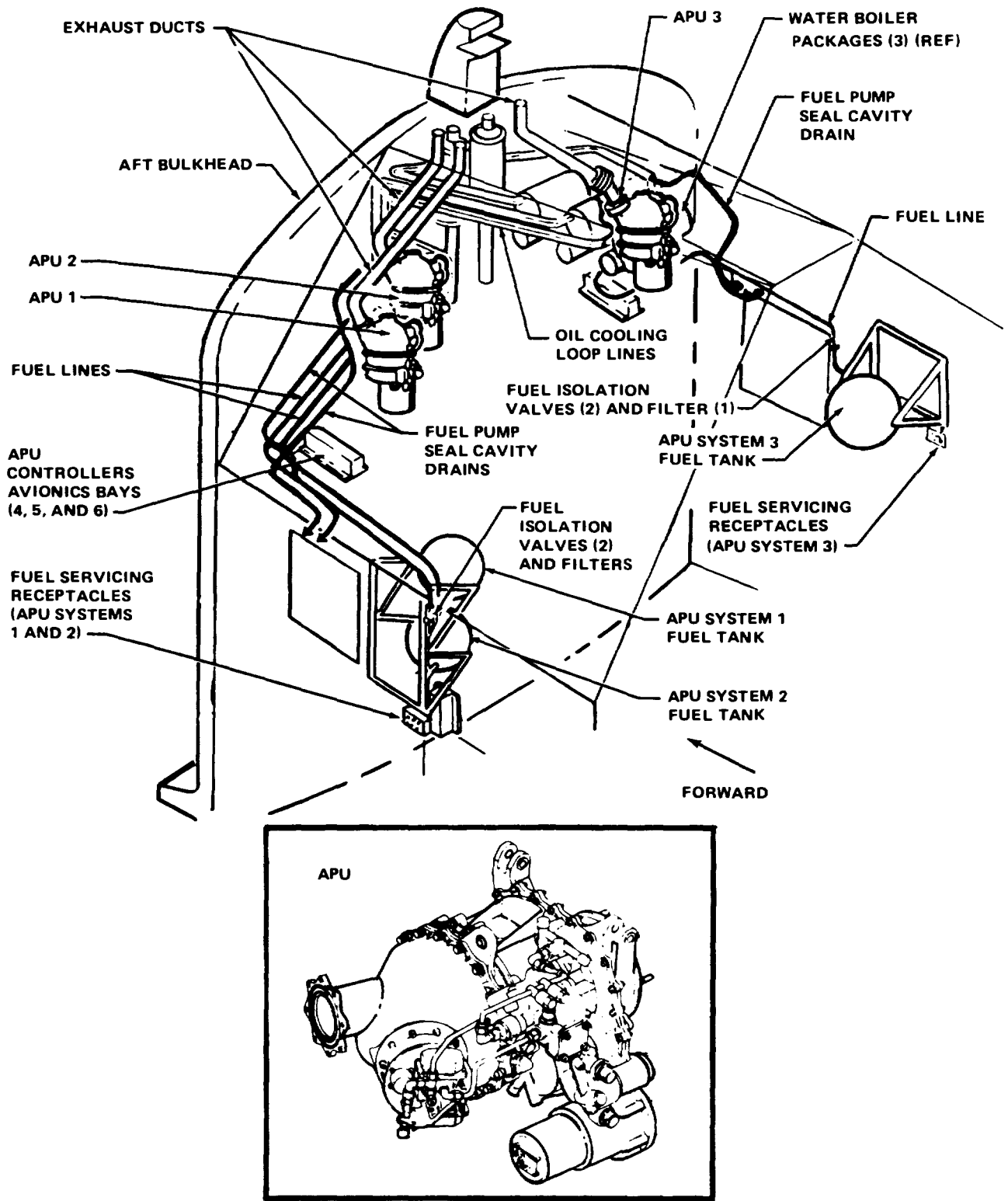
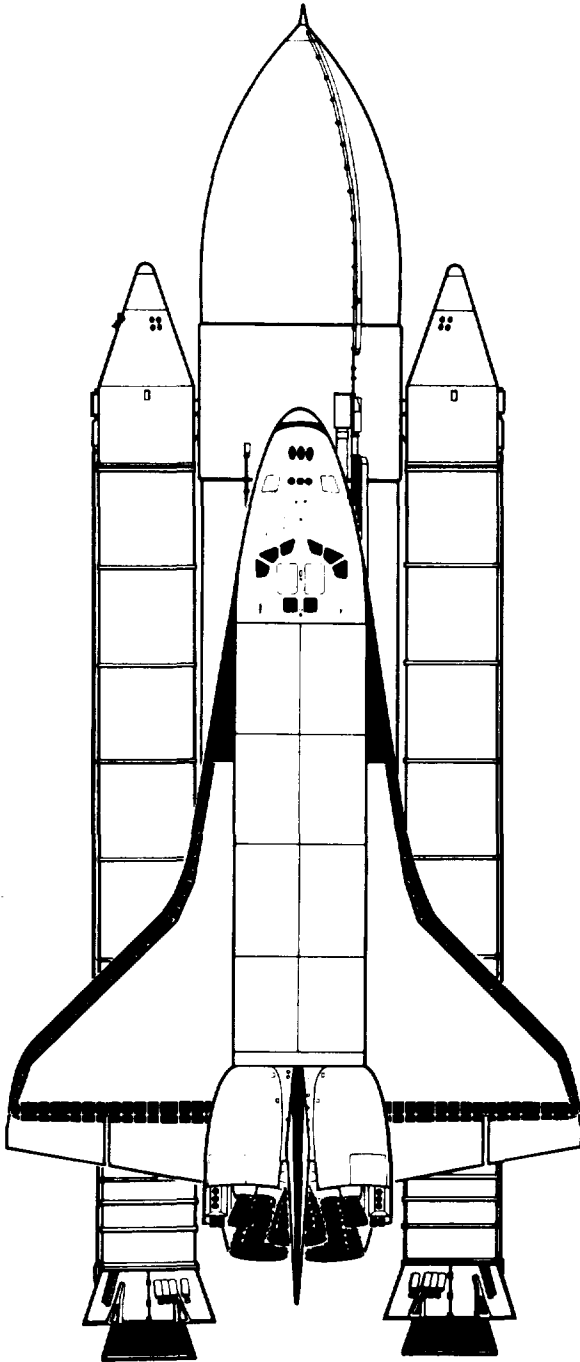

Figure 4-5.—Orbiter auxiliary power unit system.

4. ORBITER SYSTEMS

Environmental Control and Life Support System

PRESSURIZATION SYSTEM	4-19
AIR REVITALIZATION SYSTEM	4-21
ACTIVE THERMAL CONTROL SYSTEM.....	4-21
WATER AND WASTE MANAGEMENT SYSTEM	4-23
Water Supply	4-23
Waste Collection.....	4-23
FIRE DETECTION AND SUPPRESSION SYSTEM	4-24



Briefly...

The Orbiter's environmental control and life-support system scrubs the cabin air, adds fresh oxygen, keeps the pressure at sea level, heats and cools the air, and provides drinking and wash water and a toilet not too unlike the one at home.

- 1 WATER LOOP
- 2 INTERCHANGER HEAT EXCHANGER
- 3 PAYLOAD HEAT EXCHANGER
- 4 FREON LOOP
- 5 FUEL CELLS
- 6 AFT COLDPLATES
- 7 GROUND SUPPORT EQUIPMENT HEAT EXCHANGER
- 8 AMMONIA EVAPORATOR
- 9 HYDRAULIC HEAT EXCHANGER
- 10 MID COLDPLATES
- 11 FUEL CELL HEAT EXCHANGER
- 12 AVIONICS HEAT EXCHANGERS AND FANS
- 13 INERTIAL MEASUREMENT UNIT HEAT EXCHANGER AND FANS
- 14 WATER PUMPS
- 15 CONDENSER
- 16 WATER SEPARATORS
- 17 CABIN FANS LITHIUM HYDROXIDE
- 18 WATER CHILLER
- 19 LIQUID COOLING GARMENT HEAT EXCHANGER
- 20 FREON PUMPS

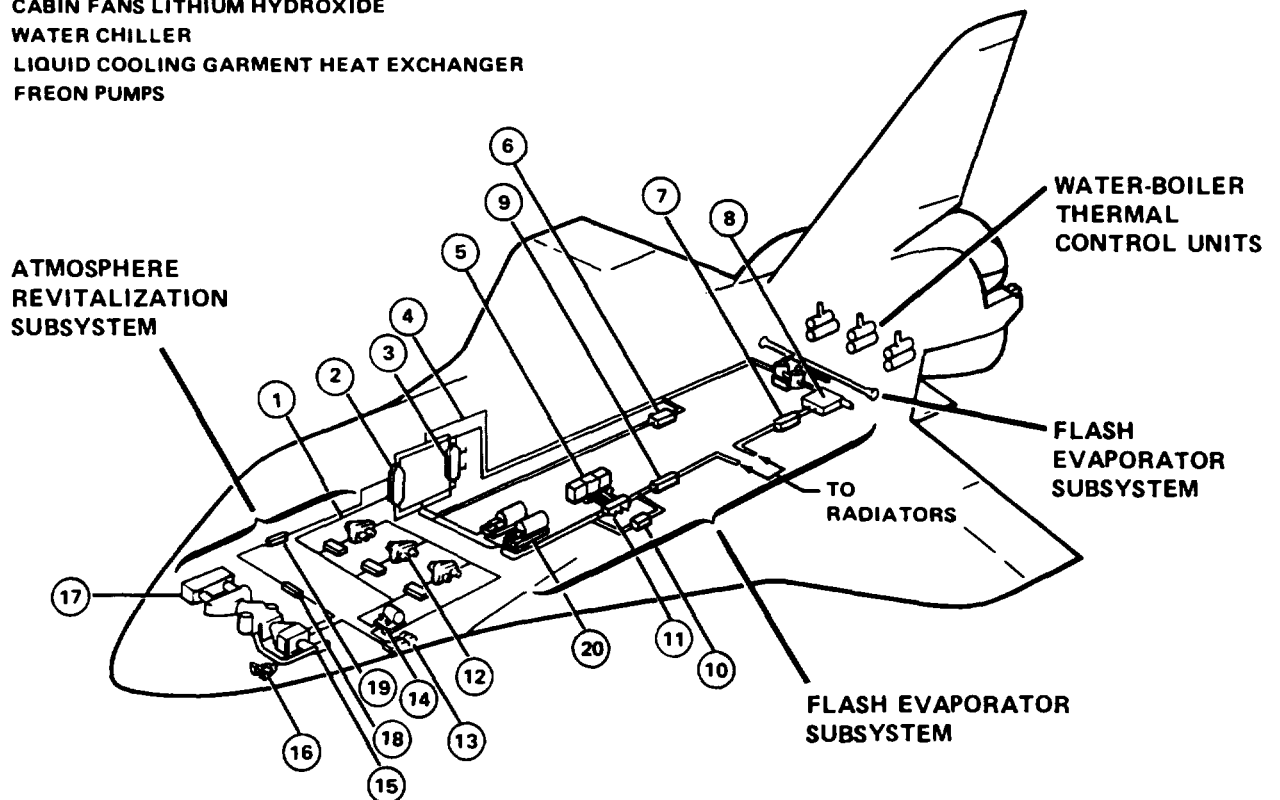
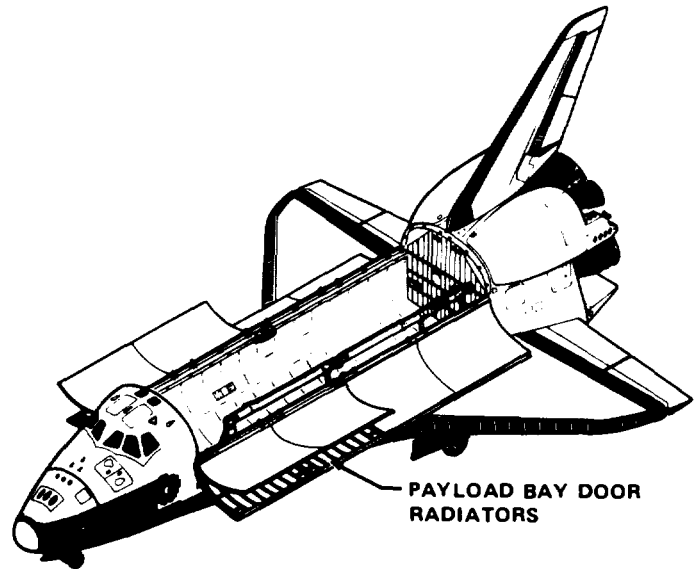

Environmental Control and Life Support

The environmental control and life support system (ECLSS) provides a comfortable shirt-sleeve habitable environment (289 to 305 K (16° to 32°C or 61° to 90°F)) for the crew and a conditioned thermal environment (heat controlled) for the electronic components. The ECLSS bay, which includes air-handling equipment, lithium hydroxide canisters, water circulation pumps, and supply and waste water, is located in the mid deck of the Orbiter and contains the pressurization system, the air revitalization system, the active thermal control system, and the water and waste management system. The systems interact to pressurize the crew compartment with a breathable mixture of oxygen and nitrogen (21 and 79 percent, respectively) while keeping toxic gases below harmful levels, controlling temperature and humidity, cooling equipment, storing water for drinking and personal hygiene and spacecraft cooling, and processing crew waste in a sanitary manner. Components of the ECLSS are shown in figure 4-6.

The electrical power system provides the ECLSS with drinking water, oxygen for the cabin atmosphere, and power to run the fans, pumps, and electrical circuits. In return, the ECLSS provides heat removal for the electrical power system. The ECLSS is the prime heat removal system onboard the Orbiter and thus interfaces with all other Shuttle systems.

The pressurization system provides a mixed-gas atmosphere of oxygen and nitrogen at sea level pressure (101.4 kN/m² (14.7 psia)). The air revitalization system controls the relative humidity (between 35 and 55 percent) and the carbon dioxide and carbon monoxide levels; it also collects heat by circulating the cabin air and then transfers the heat to the active thermal control system. The active thermal control system collects additional heat and transports it to the exterior of the spacecraft through water and Freon circulating loops. The water and waste management system provides the basic life-support functions for the crew.

PRESSURIZATION SYSTEM

Pressurization helps provide structural stability and aids in the transfer of heat from crew and equipment. The Orbiter is pressurized with 21 percent oxygen and 79 percent nitrogen, which provides a breathable atmosphere comparable to that of the normal Earth environment.

The spacecraft cabin compartment is normally maintained at sea level pressure (101.4 kN/m² (14.7 psia)) and is kept at this pressure by a regulator. In an emergency, this regulator can be turned off and another regulator will maintain the cabin at 55 kN/m² (8.0 psi).

The pressurization system is composed of two oxygen systems, two nitrogen systems, and one emergency oxygen system. Oxygen comes from the same cryogenic storage tanks that supply the electrical power system. The cryogenic oxygen pressure is controlled by heaters to 575.7 to 587.4 kN/m² (835 to 852 psi) and is delivered in gaseous form to the oxygen ECLSS supply valve.

When the oxygen system supply valve is opened, oxygen is permitted to flow through a restrictor that is basically a heat exchanger where the oxygen is warmed before passing through the regulators.

The nitrogen system has four storage tanks, two 23-kilogram (50-pound) 22 750-kN/m² (3300-psi) tanks for each of the two redundant systems, nitrogen system 1 and nitrogen system 2. The storage tanks are constructed of filament-wound Kevlar fiber with a titanium liner and are located in the forward payload bay. The gaseous nitrogen tank is filled to a pressure of 22 750 kN/m² (3300 psi) before lift-off. Motor control valves control the 22 750-kN/m² (3300-psi) inlet to the 1380-kN/m² (200-psi) regulator. Nitrogen arrives at the oxygen and nitrogen control valve at 1380 kN/m² (200 psig). These pressures—oxygen at 690 kN/m² (100 psi) and nitrogen at 1380 kN/m² (200 psi)—are important to the operation of the two-gas pressurization system.

There are numerous openings in the crew compartment to provide for proper airflow for pressure-control purposes. A negative relief valve will open when a pressure differential of 1.4 kN/m² (0.2 psi) is detected. This ensures that if the pressure in the compartment is lower than that outside the pressure vessel, flow into the cabin will take place. The inlets (orifices) are sealed with tethered caps that are dislodged by a negative pressure of 1.4 kN/m² (0.2 psid).

The isolation and vent valves provide for flow from the inside to the outside of the pressure vessel but they can reverse the flow. These valves enable the crew to vent the cabin to

ambient if the need arises. The maximum flow at 13.8 kN/m² (2 psid) is 408 kg/hr (900 lb/hr). The cabin relief valves, when enabled, provide protection against pressurization of the vehicle above 107 kN/m² (15.5 psid). If initiated, the valves will open and flow to a maximum of 68 kg/hr (150 lb/hr).

At approximately 1 hour 26 minutes before launch, the cabin is pressurized by ground support equipment to approximately 110 kN/m² (16 psi) for a leak check. The isolation and vent valves are then opened and the spacecraft is allowed to return to 105.5 kN/m² (15.3 psi). The vent valve is then closed.

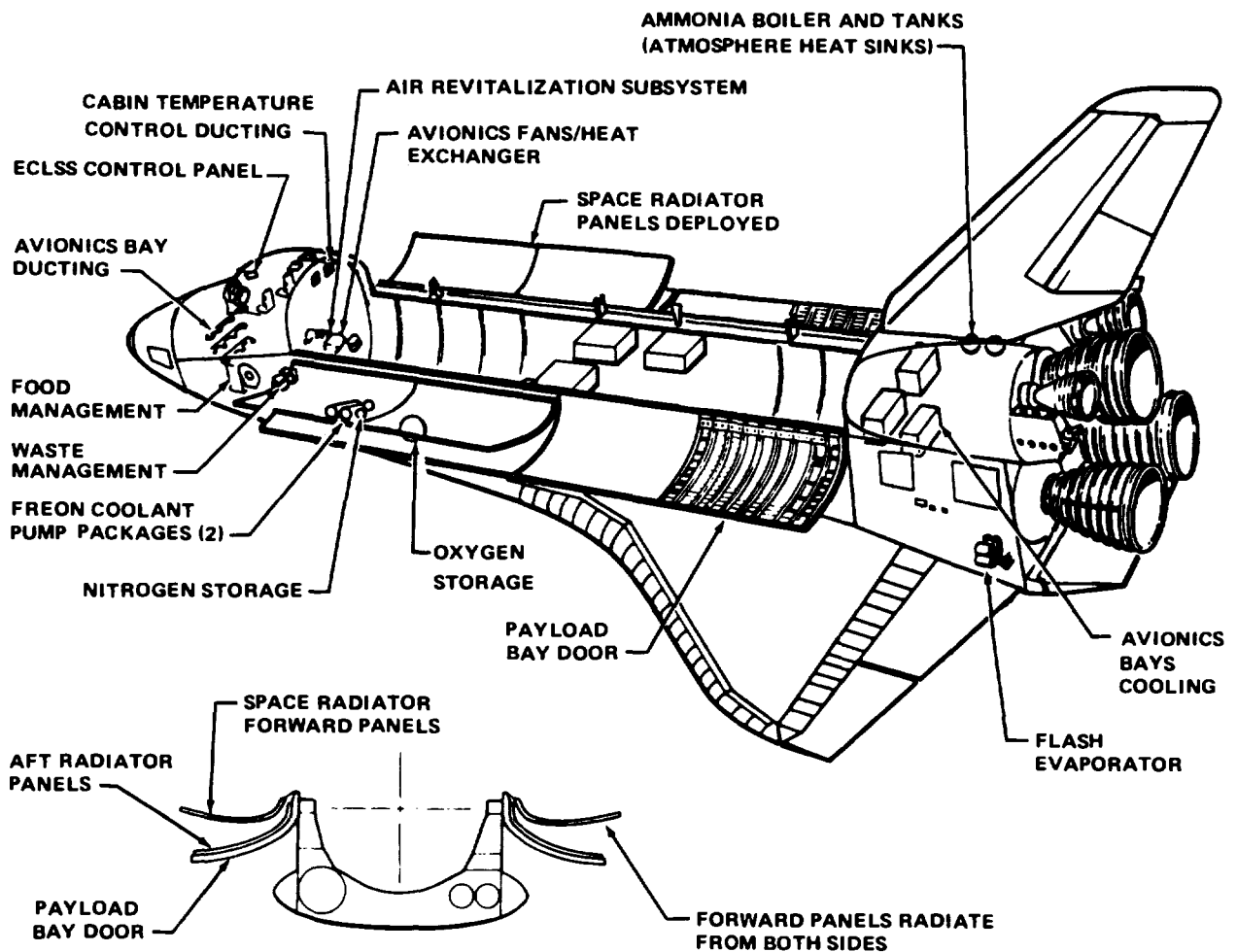

Figure 4-6.—Orbiter environmental control and life-support system.

AIR REVITALIZATION SYSTEM

Air circulation is provided by two cabin fans, only one of which will be used at a time. Each fan turns at 11 200 rpm, propelling the air (up to 635 kg/hr (1 400 lb/hr)) to the lithium hydroxide (LiOH) canisters that cleanse it. The canisters contain a mixture of activated charcoal, which removes the odor, and lithium hydroxide, which removes the carbon dioxide. The canisters are changed on a scheduled basis.

Heated cabin air is passed through the cabin heat exchanger and transferred to the water coolant loop. Additional heat is collected from the electronics. Two cabin temperature controllers respond to the cabin temperature as set by the crew, but only one controller is used at a time. During flight, the controller senses the temperature in the supply and return air ducts and controls the temperature between 291 and 300 K (18° and 27°C or 65° and 80°F).

Crew compartment humidity is controlled as air is drawn across coldplates in the cabin heat exchanger. Temperature change as the cabin air passes over these coldplates causes condensation. Centrifugal fans separate the water and air; the air is returned to the cabin and the water is forced into the waste tank. This system can remove up to 1.8 kilograms (4 pounds) of water each hour.

Two fans located in the avionics bay provide the required airflow for the enclosed air circulation system. Each avionics bay has a heat exchanger to cool the air as it is circulated.

ACTIVE THERMAL CONTROL SYSTEM

As the active thermal control system circulates the cabin air, it collects excess heat from the crew and the flight-deck electronics; two water circulation systems, two Freon circulation systems, the space radiators, the flash evaporators, and the ammonia boilers transfer the collected heat into space.

Two complete and separate water coolant loops (loops 1 and 2) flow side by side throughout the same area of the spacecraft collecting excessive heat from the avionics bays, cabin windows, and various other components. The only difference in the two systems is that loop 1 has two pumps, whereas loop 2 has a single pump. Between 500 and 590 kilograms (1 100 and 1 300 pounds) of water pass through each loop each hour. Both loops will be used during lift-off, ascent, and entry. Loop 2 will be used exclusively for orbital operations.

The circulating coolant water collects heat from the cabin heat exchanger and from coldplates throughout the cabin area. When the water passes through the Freon interchanger, the heat is passed to the Freon coolant loops and is then delivered to the radiators, the primary heat reaction system onboard the Orbiter.

Two complete and identical Freon coolant loops, each with its own pump package and accumulator, transport the heat loads to the radiator system. The primary Freon coolant loop also cools the spacecraft fuel cells. Because Freon can be toxic under certain conditions, it does not flow through the cabin compartment. The Freon coolant loop does collect heat from various coldplates outside the crew compartment. Heat collected by the active thermal control system is finally ejected from the spacecraft by the space radiators and flash evaporators.

The space radiators, which consist of two deployable and two fixed panels on each payload door (fig. 4-7), are active during orbital operations when the payload bay doors are opened. The radiator panels contain 111 square meters (1 195 square feet) of effective heat dissipation area. Each panel is 3 meters (10 feet) wide and 4.6 meters (15 feet) long.

The aft panels are single sided whereas the forward panels are double sided, allowing heat dissipation on both sides of the panel. Each panel contains parallel tubes through which the Freon heat loop fluid passes. There are 68 tubes in the forward panels and 26 in each of the aft panels. More than 1.5 kilometers (1 mile) of Freon tubing is in the radiator panels.

This system is designed to have a heat-rejection capability of 5480 kJ/hr (5200 Btu/hr) during ascent (with the payload bay doors closed) and 23 kJ/hr (21.5 Btu/hr) during orbital operations (with the payload bay doors open).

The flash evaporator and the ammonia boilers provide for the transfer of waste heat from the Freon heat transport loop to water, using the latent heat capacity of water. This system functions during Orbiter operations at altitudes above 43 kilometers (140 000 feet) during ascent and above 30.5 kilometers (100 000 feet) during entry.

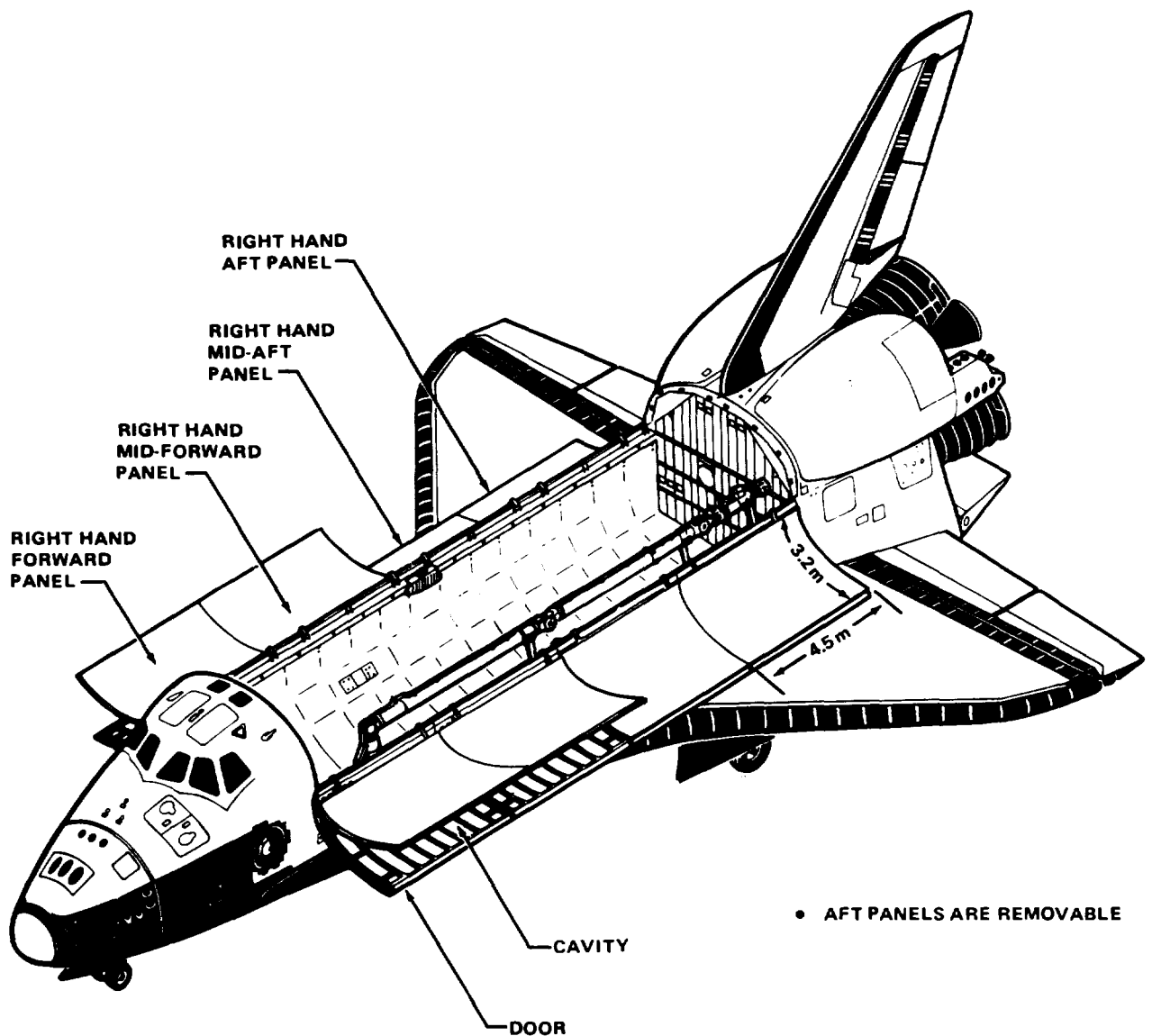

Figure 4-7.— Orbiter radiator panels.

WATER AND WASTE MANAGEMENT SYSTEM

Water Supply

Water for crew use (food preparation, drinking, and personal hygiene) onboard the Orbiter is furnished as a byproduct of the fuel cell operation. The drinkable water generated by this operation is fed into the storage tanks at the flow rate of approximately 3.2 kg/hr (7 lb/hr). The water temperature is about 283 K (10°C or 50°F). When the water tanks are full, a fuel cell relief valve automatically dumps the excess water overboard.

WASTE COLLECTOR

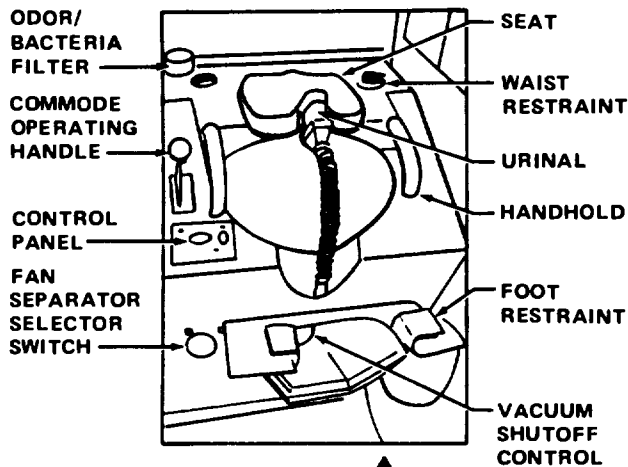

ORBITER MID DECK

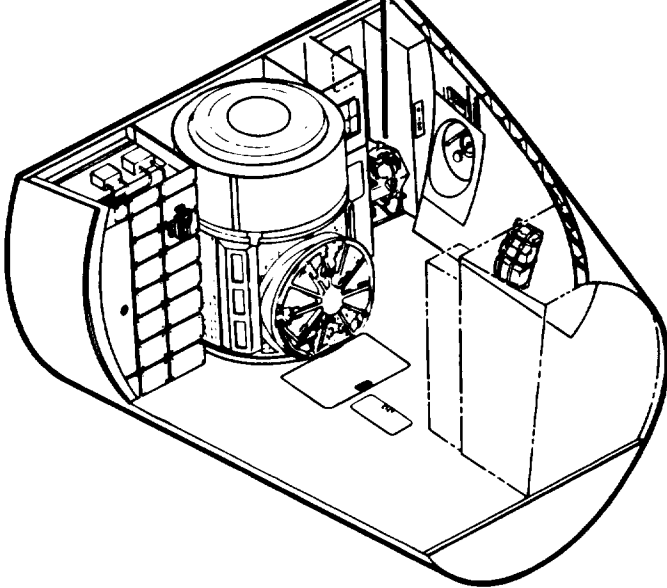

Bacteria are controlled by a microbial check valve located in the supply line between the fuel cells and the potable water supply tank. Two 75-kilogram (165-pound) water tanks are provided as a supply source for the flash evaporators and one tank is isolated to provide potable water to the galley.

Waste Collection

The waste collection system (WCS) (fig. 4-8) is an Earth-like commode system for crewmembers of the Orbiter. It is an integrated multifunctional operational device used to collect and process biowastes from both males and females as well as wash water from the personal hygiene station and cabin condensate water from the cabin heat exchanger.

The waste collection system accommodates both male and female crewmembers and consists of the commode assembly, the urinal assembly, instrumentation, interconnection plumbing, the mounting framework, and restraints. It is located on the mid deck of the Orbiter in a compartment immediately aft of the side hatch. The unit is approximately 69 by 69 by 74 centimeters (27 by 27 by 29 inches) and has two major independent and interconnected assemblies: the urinal, designed to handle fluids, and the commode, to handle the solid waste. Two privacy curtains of Nomex cloth are attached to the inside of the compartment door and serve to isolate the WCS compartment and the galley personal hygiene station from the rest of the mid deck.

Figure 4-8.—Orbiter waste collection system.

C-2

Designed for use both in the weightless space environment and in Earth's atmosphere, the waste collection system is used in the same manner as facilities onboard jet airliners. It differs from conventional bathroom commodes in that separate receptacles for the collection of liquid and solid body wastes are built into the seat. In space, high-velocity airstreams compensate for Earth's gravity to force waste matter into respective chambers. Airstreams also assist in the operation of a water-flush mechanism for cleaning after each use. The waste matter is vacuum dried, stored, and chemically treated to prevent odor and bacterial growth. Like toilets on airliners, the facility will be serviced when the Orbiter lands back on Earth.

Foot restraints, a waist restraint, and handholds are part of the WCS. The foot restraints are simple toeholds attached to a foldup step. The handholds are multipurpose and can be used for positioning or actual stabilization at the option of the user. The waist restraint encircles the user around the waist and is attached to two lateral positions. The restraint has a negator spring takeup reel that removes slack in the belt and exerts an evenly distributed downward force on the user to ensure an adequate seal between the user and the seat.

FIRE DETECTION AND SUPPRESSION SYSTEM

The Orbiter fire detection and suppression system consists of two related but not physically connected subsystems, the detection system and the suppression system. There are four portable Freon (1301) fire extinguishers and three fixed extinguishers onboard the Orbiter.

Nine early warning smoke detectors sense any significant increase in the gaseous or particulate products of combustion within the crew compartment or avionics bays. Should a significant increase occur, a signal illuminates a warning light on the fire detection and suppression control panel and activates a siren.

Two smoke detectors are located in each of the three avionic bays. When smoke is detected, appropriate signals displayed on the fire detection and suppression control panel warn the crew to take necessary action. If the sensors detect smoke in the avionics bay, the crew initiates the appropriate system, which will extinguish the fire in a minimum time. One Freon 1301 extinguisher is mounted in each avionics bay. Each avionics bay extinguisher has 1.6 kilograms (3.5 pounds) of Freon 1301 in a pressure vessel 20.3 centimeters (8 inches) long and 11.4 centimeters (4.5 inches) in diameter.

If sensors detect smoke anywhere in the crew compartment or behind the electrical panels, the crew will use one of the portable extinguishers. These portable devices are 33.5 centimeters (13.2 inches) long and can be used as a backup for the avionics bay extinguisher. The portable extinguishers have a tapered nozzle that can be placed into fire holes on the electrical panels to extinguish fires behind the panels.

The fire suppressant Freon 1301 (bromotrifluoromethane) is one of the most effective chemical fire suppressants. The mechanism by which it operates is by breaking the chemical chain reaction in a flame rather than by smothering it. A relatively small amount of the chemical (less than 6 percent) is sufficient to suppress a fire.

4. ORBITER SYSTEMS

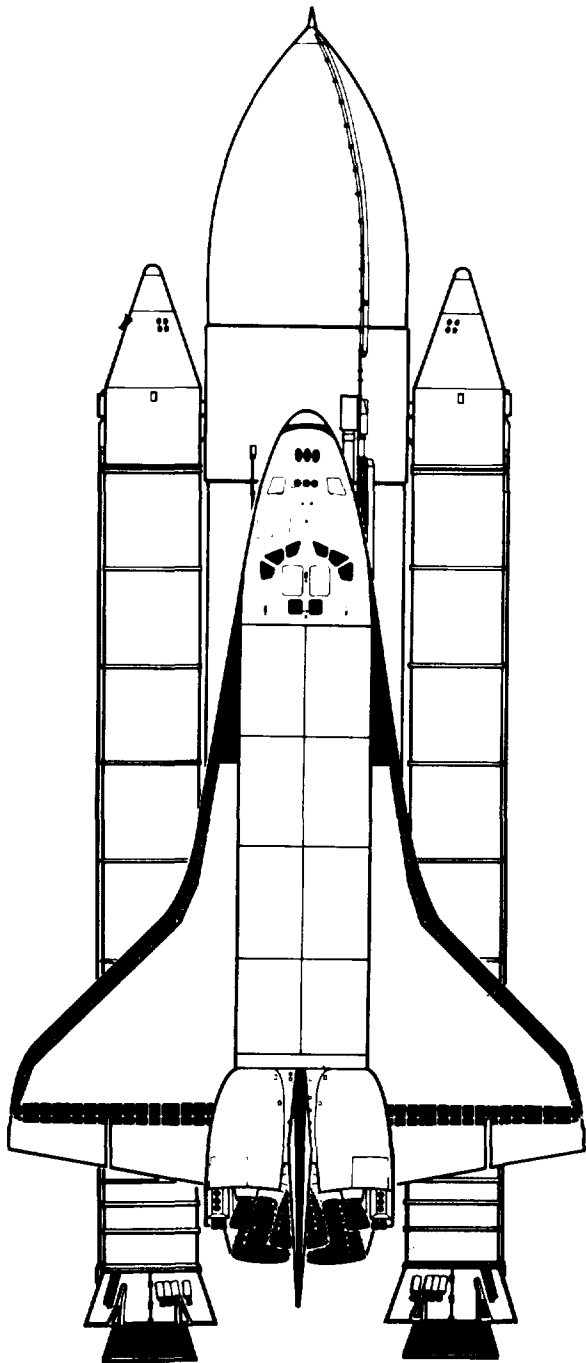

Thermal Protection

REUSABLE SURFACE INSULATION.....	4-27
PASSIVE THERMAL CONTROL	4-30

Briefly . . .

Silica glass tiles bonded to the Orbiter's skin have prompted some to call the spacecraft the "flying brickyard." The tiles on the outside and several types of insulation materials on the inside protect the Orbiter from temperature extremes while in orbit and from the searing heat of entering the atmosphere on the return trip. The lightweight glass tiles require only minor refurbishing between flights.

Insulation	Temperature limits	Area, m ² (ft ²)	Weight, kg (lb)
Flexible reusable surface insulation	Below 644 K (371° C or 700° F)	319 (3 436)	499 (1 099)
Low-temperature reusable surface insulation	644 to 922 K (371° to 649° C or 700° to 1200° F)	268 (2 881)	917 (2 022)
High-temperature reusable surface insulation	922 to 978 K (649° to 704° C or 1200° to 1300° F)	477 (5 134)	3826 (8 434)
Reinforced carbon-carbon	Above 1533 K (1260° C or 2300° F)	38 (409)	1371 (3 023)
Miscellaneous			632 (1 394)
Total		1102 (11 860)	7245 (15 972)



Thermal Protection

The overall economic feasibility of a reusable Space Transportation System hinges on protecting the Space Shuttle Orbiter — which will experience widely varying thermal and aerodynamic environments typical of both aircraft and spacecraft — in a way that does not require significant refurbishment between trips. The thermal protection system (TPS) is designed to limit the temperature of the Orbiter's aluminum and graphite epoxy structures to a nominal value of 450 K (177° C or 350° F) during ascent and entry.

Maximum surface temperatures during entry vary from 1783 K (1510° C or 2750° F) on the wing leading edge to less than 589 K (316° C or 600° F) on the upper fuselage. The thermal protection system must also endure exposure to nonheating environments during prelaunch, launch, onorbit, landing, and turnaround operations similar to those encountered by conventional aircraft. It must also sustain the mechanical forces induced by deflections of the airframe as it responds to the same external environment. The system is designed to withstand 100 ascents and entries with a minimum of refurbishment and maintenance.

REUSABLE SURFACE INSULATION

The thermal protection system (fig. 4-9) consists of materials applied externally to the Orbiter that maintain the airframe outer skin within acceptable temperature limits. Internal insulation, heaters, and purging facilities are used to control interior compartment temperatures. The Orbiter thermal protection system is a passive system consisting of the following four materials, selected for weight efficiency and stability at high temperatures.

1. Coated reinforced carbon-carbon (RCC) for the nose cap and wing leading edges where temperatures exceed 1533 K (1260° C or 2300° F)
2. High-temperature reusable surface insulation (HRSI) for areas where maximum surface temperatures reach 922 to 978 K (649° to 704° C or 1200° to 1300° F)

3. Low-temperature reusable surface insulation (LRSI) for areas where surface temperatures reach 644 to 922 K (371° to 649° C or 700° to 1200° F)

4. Flexible reusable surface insulation (FRSI) (coated Nomex felt) for areas where the surface temperature does not exceed 644 K (371° C or 700° F)

The reinforced carbon-carbon is an all-carbon composite of layers of graphite cloth contained in a carbon matrix formed by pyrolysis. To prevent oxidation at elevated temperatures, the outer graphite-cloth layers are chemically converted to silicon carbide. RCC covers the nose cap and wing leading edge areas of the Orbiter, which receive the highest heating.

The high-temperature reusable surface insulation consists of approximately 20 000 tiles located predominantly on the lower surface of the vehicle. The tiles nominally measure 15 by 15 centimeters (6 by 6 inches) and vary in thickness from 1.3 to 8.9 centimeters (0.5 to 3.5 inches), depending on local heating. The high-temperature material is composed of a low-density high-purity silica fiber insulator made rigid by ceramic bonding. Each tile is bonded to a strain isolator pad made of Nomex fiber felt and the total composite is directly bonded to the vehicle.

The low-temperature reusable surface insulation consists of approximately 7000 tiles applied to the upper wing and fuselage side surfaces of the Orbiter in the same manner as the HRSI. These tiles nominally measure 20 by 20 centimeters (8 by 8 inches) and vary in thickness from 0.5 to 2.5 centimeters (0.2 to 1 inch). The low-temperature tiles are the same as the high-temperature tiles except that the coating has a different optical pigment for obtaining low solar absorbance and high solar emittance. These two sets of tiles cover approximately 70 percent of the Orbiter.

The basic raw material for the tiles is a high-purity amorphous short-staple silica fiber that was selected for its low thermal conductivity, low thermal expansion, and high-temperature stability. The reusable tiles can easily be repaired. Coating scratches can be repaired in place by spray techniques and torch firing and small gouges or punctures can be cored out and replaced with standard size plugs. Complete tiles can be removed and replaced in 45 hours.

The flexible reusable surface insulation consists of 0.9- by 1.2-meter (3- by 4-foot) sheets of Nomex felt that are directly bonded to the structure. Before installation, the Nomex felt, which varies in thickness from 0.41 to 1.62 centimeters (0.16 to 0.64 inch), is coated with a silicone elastomeric film to waterproof it and to give the surface the desired optical properties. The Nomex felt is applied to the upper parts of the payload bay doors, the sides of the fuselage, and the upper wing.

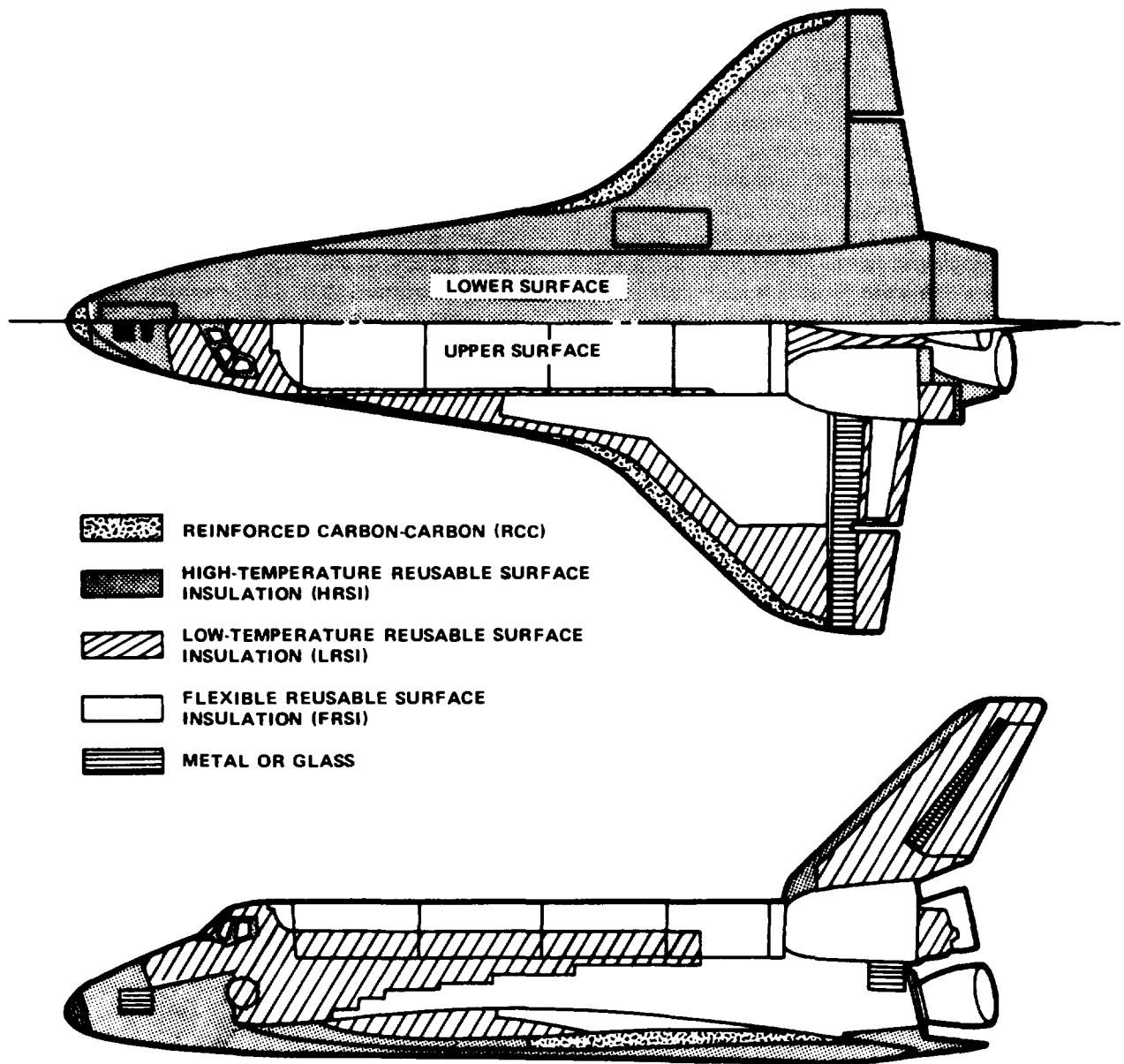
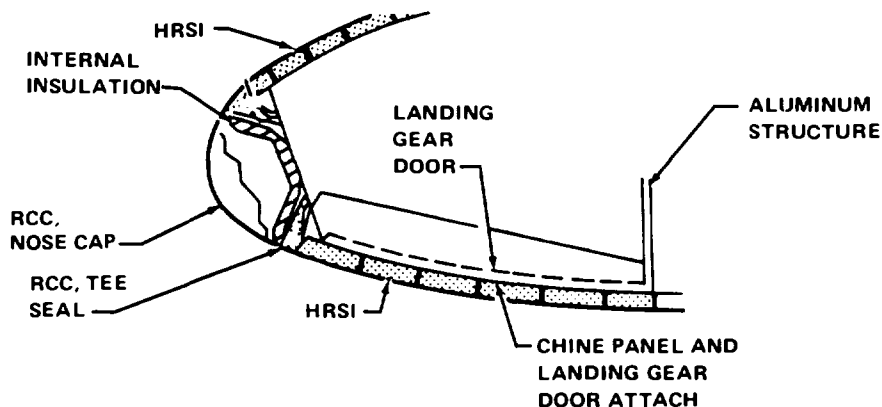

Figure 4-9.— Orbiter thermal protection system.

Typical interfaces with the thermal protection system are shown in figure 4-10. The leading edge subsystem to HRSI transition is shown for the nose and outer wing leading edge. A typical joint for the two tile systems is also shown.

The tiles are bonded to the aluminum skin with RTV 560 (a silicone resin cement) with a strain isolator pad in between. Filler bars are installed under the tiles at the intertile gaps. In areas where high surface pressure gradients would cause crossflow of boundary-layer air within the intertile gaps, tile gap fillers are provided to minimize increased heating within the gaps. The gap fillers are fabricated using a silica fiber cloth cover with an alumina fiber filler.

LEADING EDGE - NOSE SECTION



LEADING EDGE - WING SECTION

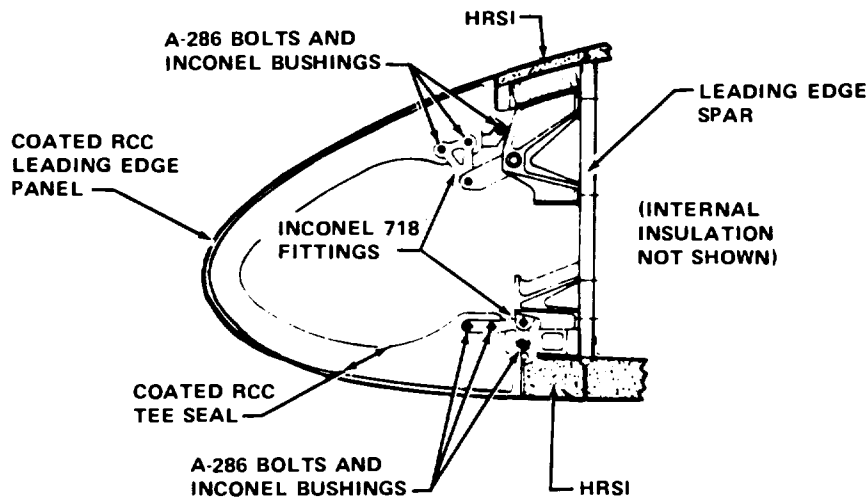

HRSI AND LRSI

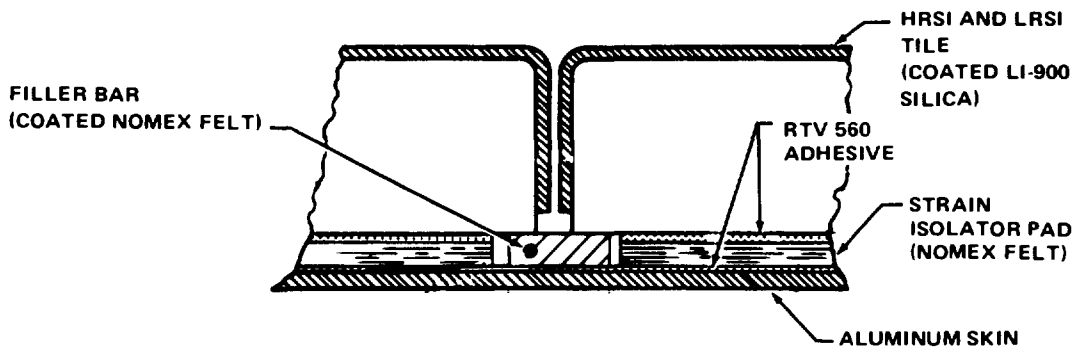

Figure 4-10.— Thermal protection system interfaces.

PASSIVE THERMAL CONTROL

A passive (nonactive) thermal control system helps maintain spacecraft systems and components at specified temperature limits. This system uses available spacecraft heat sources and heat sinks supplemented by insulation blankets, thermal coatings, and thermal isolation methods. Heaters are provided on components and systems where passive thermal control techniques are not adequate to maintain required temperatures.

The insulation blankets are of two basic types: fibrous bulk and multilayer (fig. 4-11). The bulk blankets are made of 32-kg/m³ (2-lb/ft³) density fibrous material with a sewn cover of reinforced double-goldized Kapton. The cover material has numerous small holes for venting purposes. Goldized tape is used for cutouts, patching, and reinforcements. Tufts are used throughout the blankets to minimize billowing during venting.

The multilayer blankets are constructed of alternate layers of perforated double-goldized Kapton reflectors and Dacron net separators for a total of 20 reflector layers, with the two cover halves counting as two layers. The covers, tufting, and goldized tape are similar to those of the bulk blankets.

BULK INSULATION

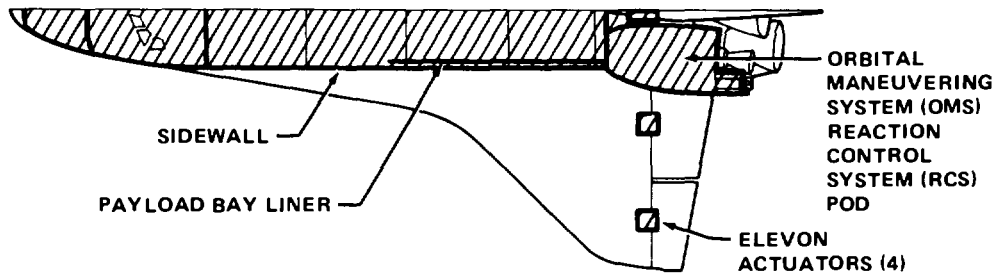

 **BULKHEAD INSULATION**
 - TG15000
 - COVER MATERIAL - DACRON GOLDIZED KAPTON REINFORCED

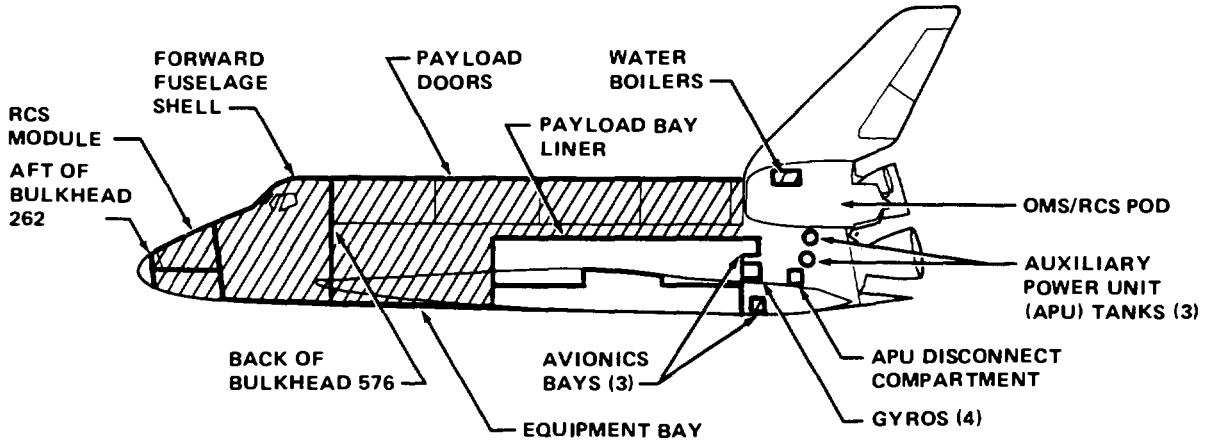

MULTILAYER INSULATION

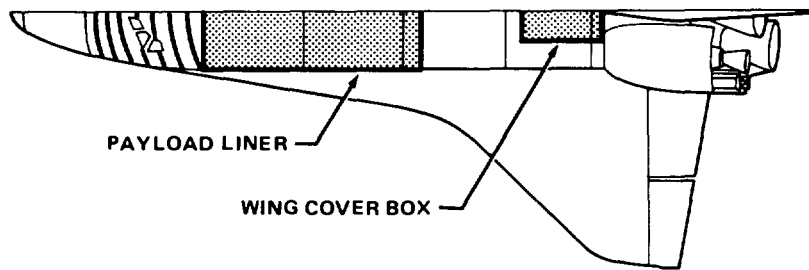

 **MULTILAYER INSULATION**
 - REFLECTORS - 8 LAYERS DACRON GOLDIZED KAPTON
 - SEPARATORS - DACRON NET
 - COVER MATERIAL - DACRON GOLDIZED KAPTON REINFORCED

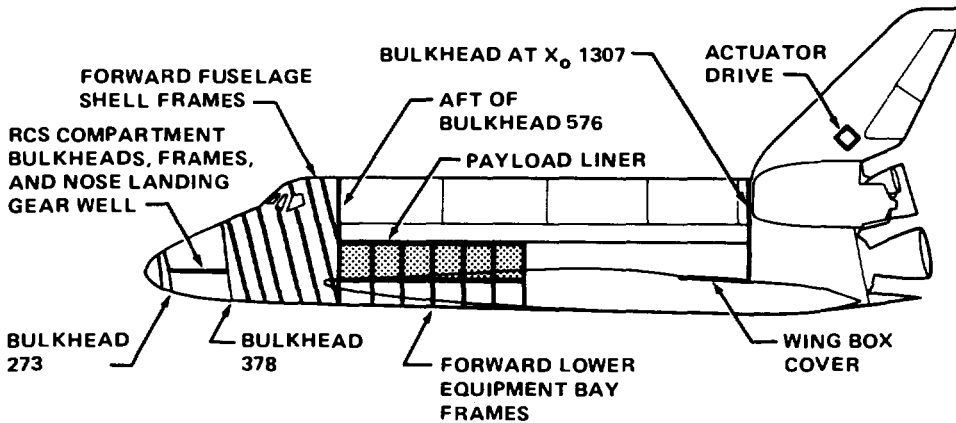
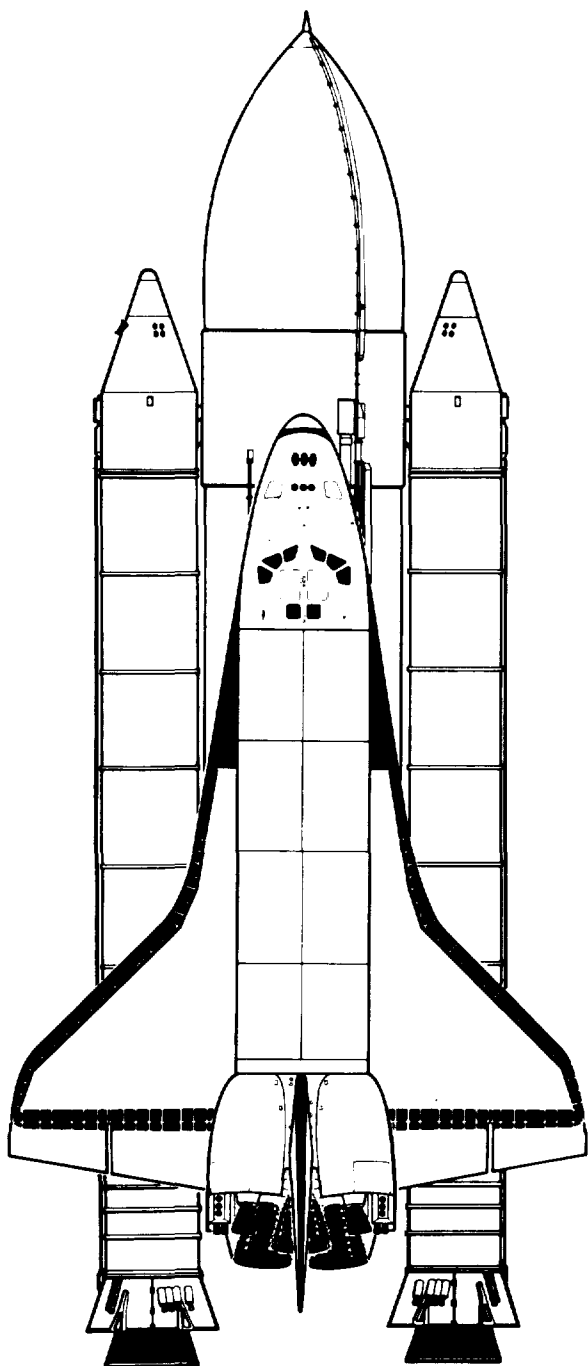

Figure 4-11.—Orbiter passive thermal control system.

4. ORBITER SYSTEMS

Purge, Vent, and Drain System



PRECEDING PAGE BLANK NOT FILMED

Briefly . . .

The purge, vent, and drain system on the Orbiter removes gases and fluids that accumulate in the unpressurized spaces of the vehicle.

PURGE SUBSYSTEM (PREFLIGHT AND POSTFLIGHT)

Circulates conditioned gas during launch preparations to remove contaminants and toxic gases and maintain specified temperature and humidity

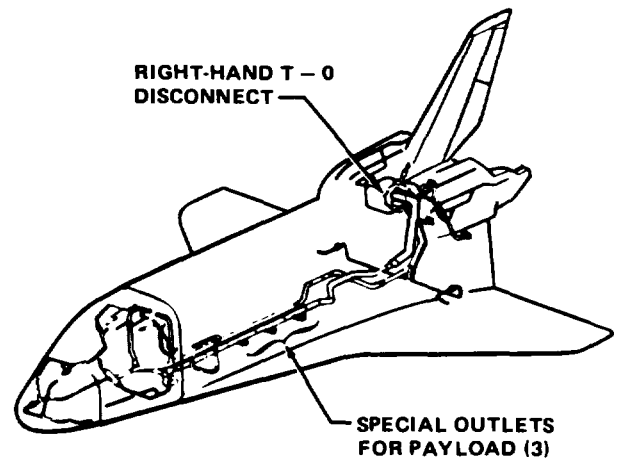

VENT SUBSYSTEM (ALL PHASES)

Allows unpressurized areas to depressurize during ascent and repressurize during descent and landing

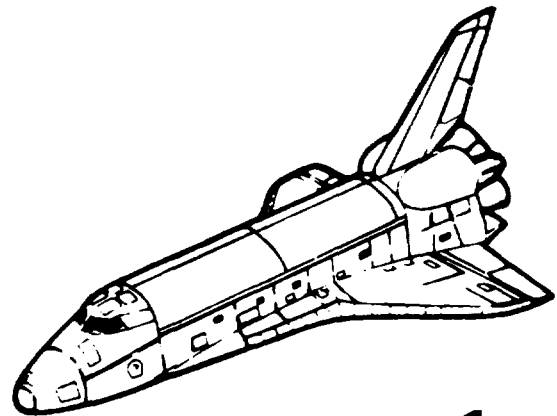

DRAIN SUBSYSTEM (PREFLIGHT AND POSTFLIGHT)

Removes accumulated water and other fluids

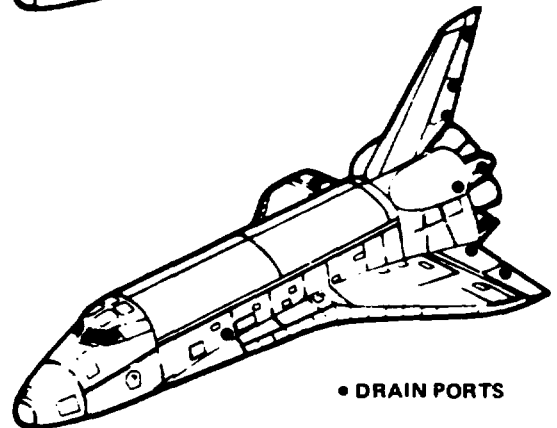

Purge, Vent, and Drain System

The Orbiter's purge, vent, and drain system (fig. 4-12) removes the gases and fluids that accumulate in the unpressurized spaces of the spacecraft and prevents ice buildup in the ground disconnect between the Orbiter and the External Tank.

During launch preparations on the pad, the purge subsystem circulates conditioned gas (air, gaseous nitrogen, or a mixture of the two) through the forward fuselage, payload bay, tail group, and orbital maneuvering system pods to remove contaminants or toxic gases as well as to maintain proper temperature and humidity levels.

The vent subsystem allows spacecraft cavities to depressurize during ascent through a series of 18 vents and outlets in the fuselage skin. These vent ports also allow repressurization during descent and landing. Electromechanical actuators open and close the vent ports.

Accumulated water and other fluids in the Orbiter drain through limber holes (much like limber holes in frames along the keel of a boat) to the lowest point for removal. Additional tubing and connections allow draining of those compartments that cannot drain through limber holes.

A separate subsystem modulates pressure in the cavities between window panes and prevents fogging or frosting of windows in flight.

On the pad, a ground-based mass spectrometer samples purged gases from the Orbiter to determine hazardous levels of explosive or toxic gases.

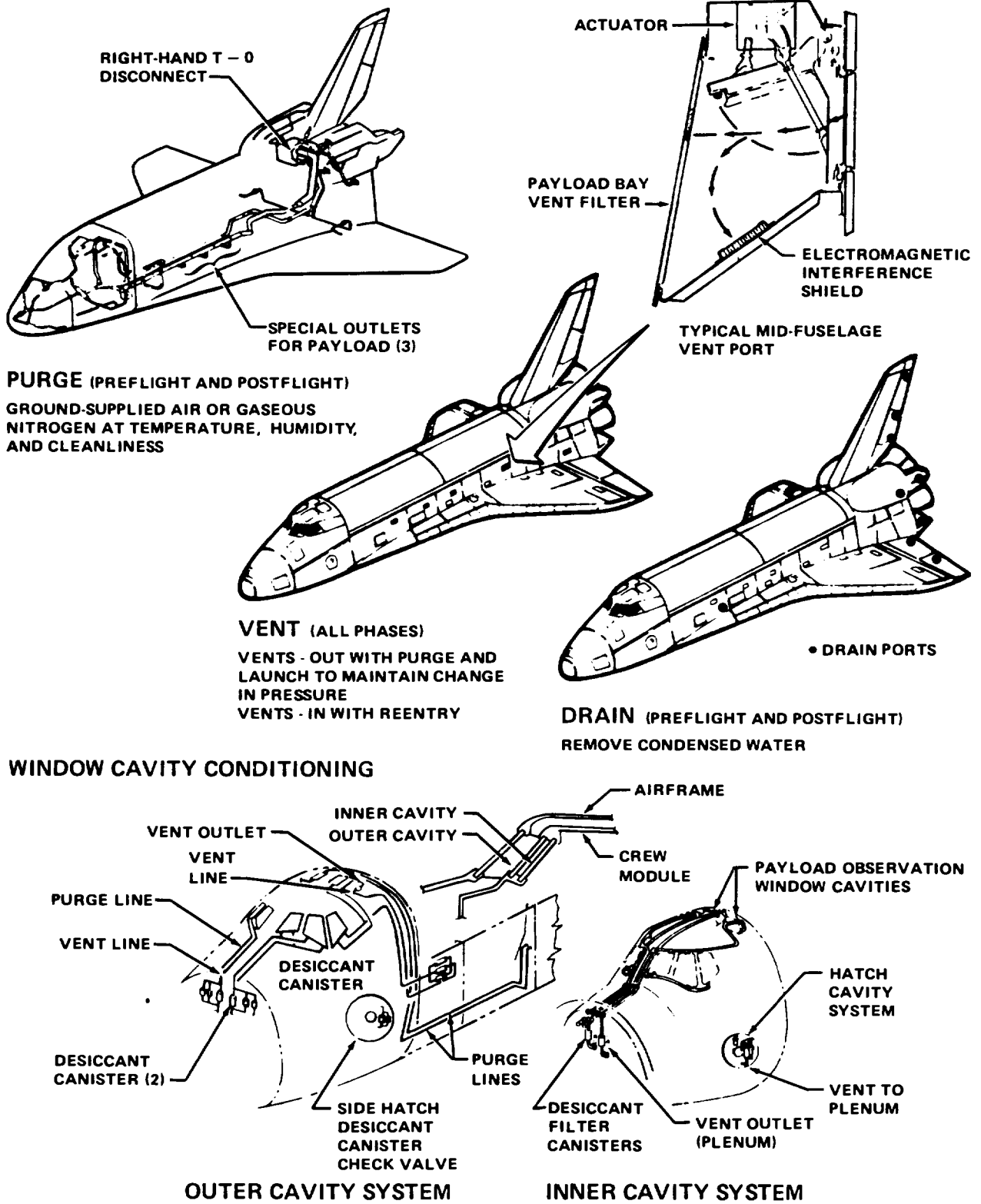
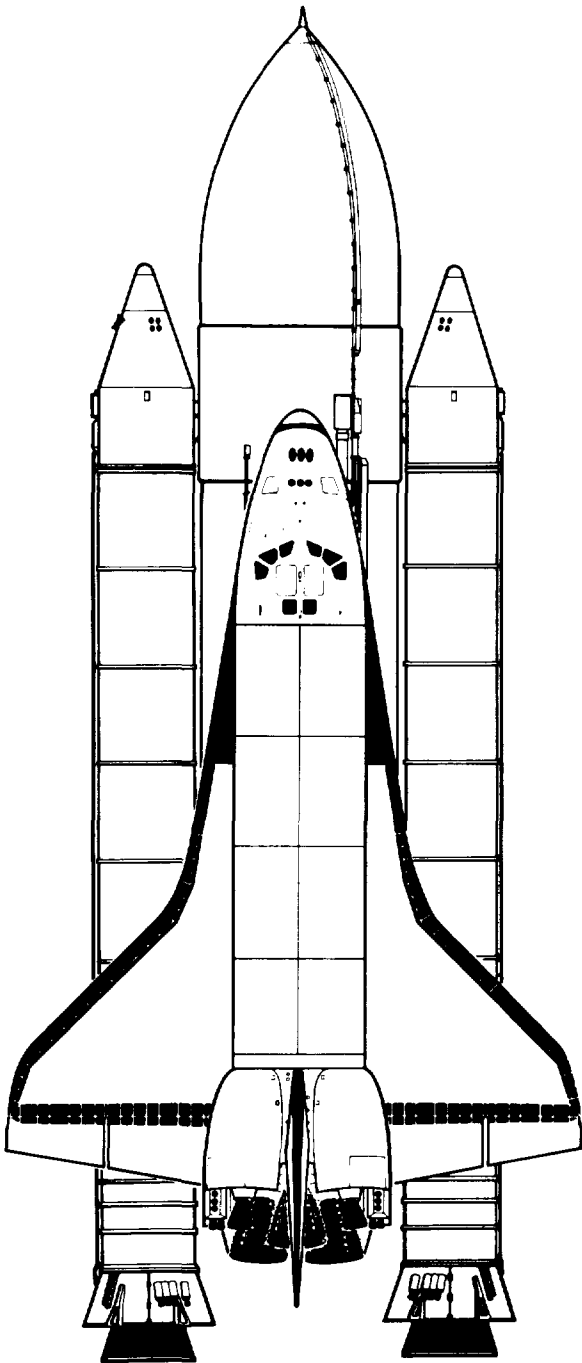

Figure 4-12.— Orbiter purge, vent, and drain system.

4. ORBITER SYSTEMS



Avionics

AVIONICS SUBSYSTEMS	4-41
Guidance, Navigation, and Control	4-41
Navigation Aids	4-41
Communications	4-41
Displays and Controls	4-41
Multifunction Display System	4-42
Electrical Power Distribution and Control	4-42
Engine Interface Unit	4-42
Payload Data Interleaver	4-42
Data Processing	4-42
Data Processing Software	4-43
GUIDANCE, NAVIGATION, AND CONTROL	4-45
Guidance, Navigation, and Control Systems	4-45
Navigation Aids	4-46
DISPLAYS AND CONTROLS	4-49
Controls	4-50
Displays	4-50
COMMUNICATIONS AND DATA SYSTEMS	4-52
Orbiter Radiofrequency Systems	4-54
Orbiter Interface With RF Systems	4-56
Orbiter Interface With Payload Data Systems	4-57
Data Record/Playback Systems	4-57
Television System	4-58
Tracking and Data Relay Satellite System	4-59
Text and Graphics Hardcopy System	4-60

Briefly . . .

The Orbiter's avionics system includes "black boxes" ranging from five computers that argue among themselves as to who's right, to cockpit navigation instruments used during the last 10 minutes of flight when the Orbiter becomes an airplane. Other avionics keep tab on the status of Orbiter systems and provide voice and data contact with Earth.

FORWARD CABIN AREA

- Star trackers
- Inertial measurement unit

FLIGHT DECK

- Manual controls
- Indicators
- Displays
- Inertial optical unit

DRIVERS AND ACTUATORS

- Aerosurfaces
- Propulsive elements

AFT AVIONICS BAYS

- Rate gyros
- Aerosurface servo amplifier
- Reaction jet OMS driver (aft)
- Multiplexer-demultiplexer units

FORWARD AVIONICS BAYS

- Tacans
- Radar altimeters
- MSBLS receivers
- Air data transducer assembly
- RCS jet driver (forward)
- General-purpose computers
- Mass memories
- Multiplexer-demultiplexer units
- UHF receiver
- Rendezvous sensor
- Electronics
- Accelerometers
- One-way Doppler extractor

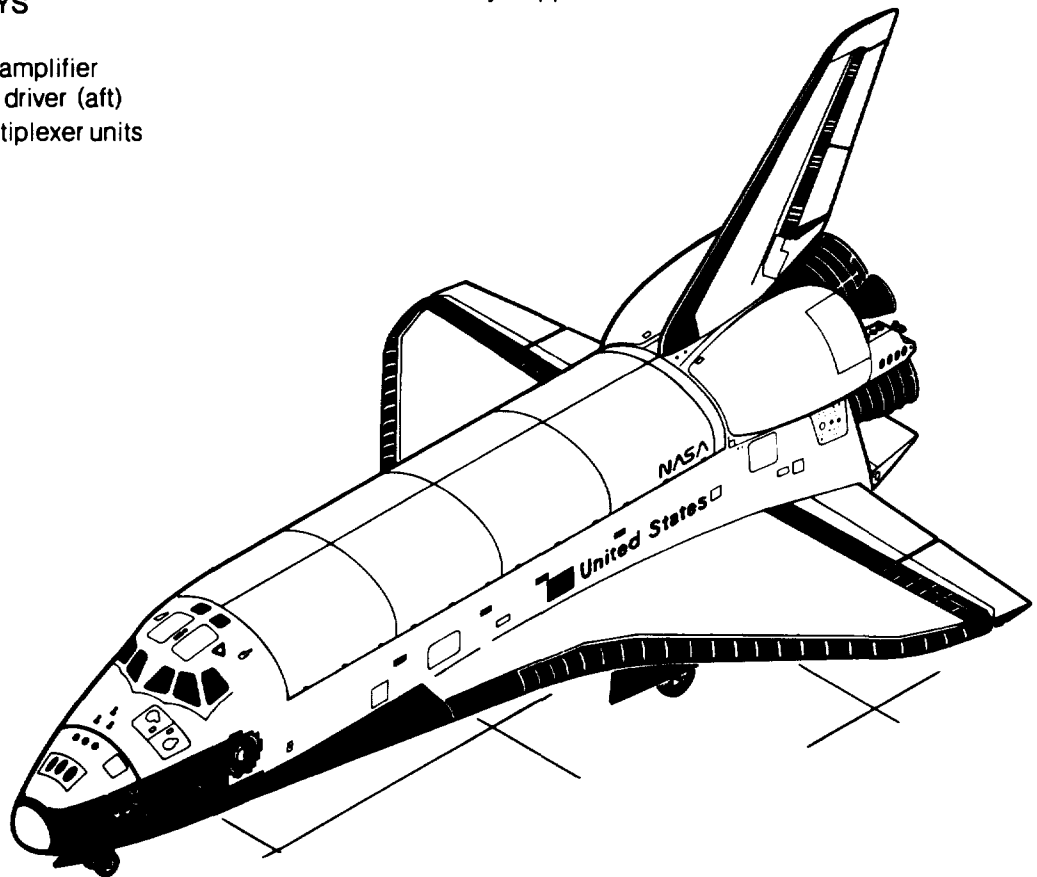

Avionics

The Shuttle avionics system controls, or assists in controlling, most of the Space Shuttle systems (fig. 4-13). Its functions include guidance, navigation, control, and electrical power distribution for the Orbiter, the External Tank (ET), and the Solid Rocket Boosters (SRB's). In addition, the avionics control the communications equipment and can control payloads. Orbiter avionics automatically determine vehicle status and operational readiness and provide sequencing and control for the External Tank and the Solid Rocket Boosters during launch and ascent. Automatic vehicle flight control can be used for every mission phase except docking. Manual control is also available at all times as a crew option.

The avionics equipment is arranged to facilitate checkout, access, and replacement with minimal disturbance to the other subsystems. Almost all the electrical and electronics equipment is installed in three areas of the Orbiter: the flight deck, the forward avionics equipment bays, and the aft avionics equipment bays (fig. 4-14).

The avionics are designed with redundant hardware and software to withstand multiple failures. The Space Shuttle avionics system consists of more than 200 electronic "black boxes" connected to a set of five computers through common party lines called data buses. The electronic black boxes offer dual or triple redundancy for every function.

The status of individual avionics components is checked by a performance monitoring computer program. The status of critical vehicle functions — such as the position of the hatches and exterior doors, ET and SRB separation mechanisms, and excessive temperatures for certain locations — is continuously monitored and displayed for the crew.

The computer programs necessary to accomplish the different avionics functions are stored in tape mass memories and transferred to the computer memories as needed. The most detailed levels of the programs are called principal functions, of which there are approximately 300. Principal functions are grouped together to create major modes concerning specific flight aspects such as first-stage ascent, orbital stationkeeping, landing, etc.

The avionics system is closely interrelated with three other systems of the Orbiter — the guidance, navigation, and control system; the controls and displays system; and the communications and data systems. These systems are thus described in this section following a discussion of the Orbiter avionics subsystems.

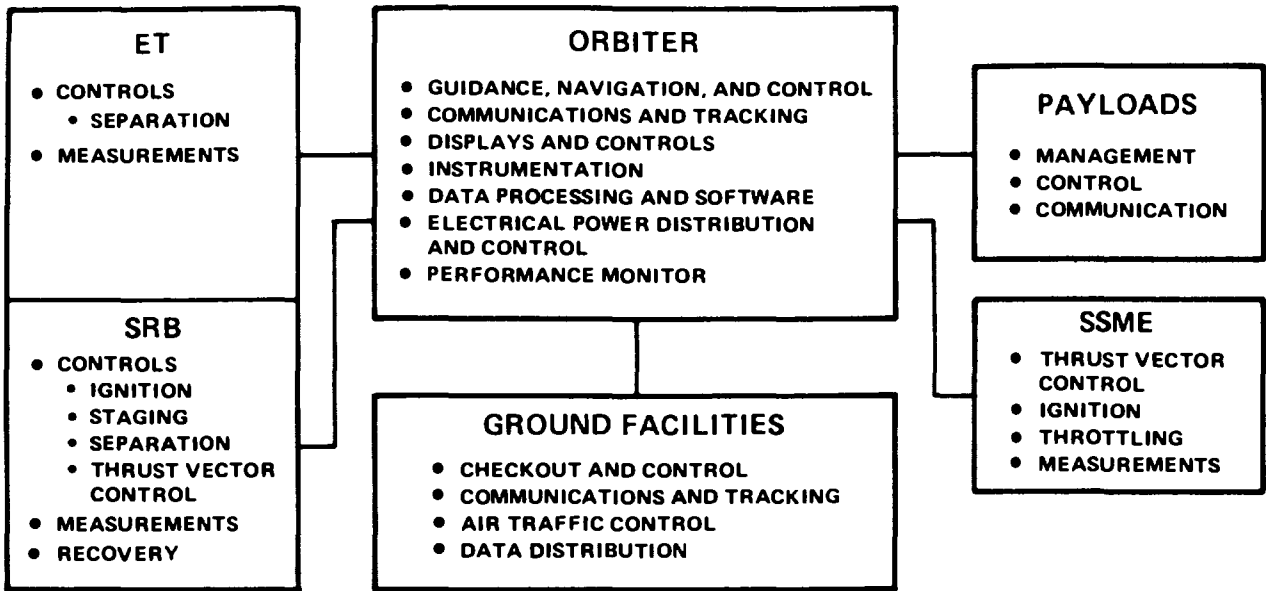

Figure 4-13.—Orbiter avionics system.

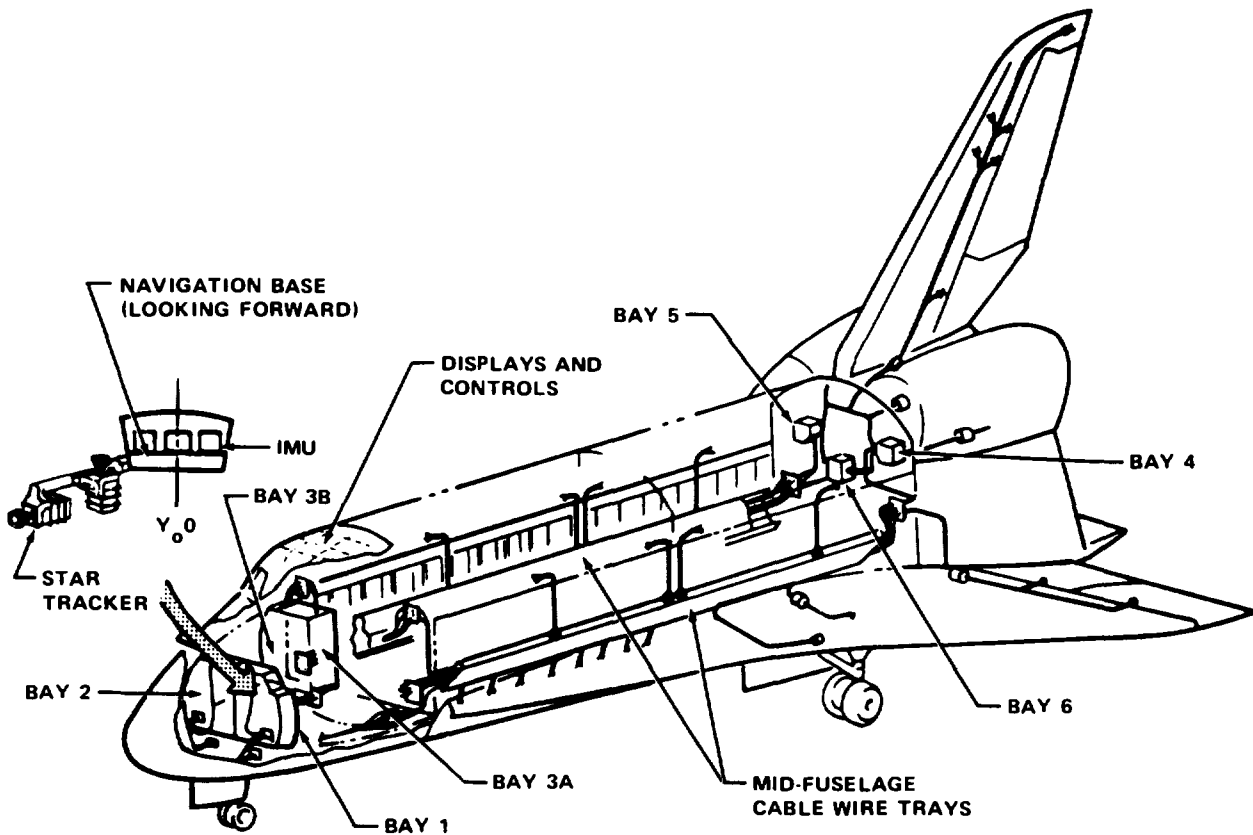

Figure 4-14.—Orbiter avionics system installation configuration.

AVIONICS SUBSYSTEMS

Guidance, Navigation, and Control

The avionics system is segregated into subsystems by function. The guidance, navigation, and control subsystem, in conjunction with the displays and controls, computers, and navigational aids, provides guidance, navigation, and automatic (or manual) control of the Shuttle in all flight phases.

Navigation Aids

The S-band phase-modulated (PM) microwave communications system can be used to provide two-way Doppler tone ranging (ground to Orbiter to ground). The Doppler shift is determined on the ground, used to compute a revised vehicle state vector,¹ and then transmitted to the spacecraft computer for onboard computational use. A one-way Doppler system on the Orbiter obtains ranging information by comparing the S-band carrier frequency shift to an onboard frequency standard. This information may also be used for vehicle position computations. A rendezvous radar is used for detecting, acquiring, and tracking active and passive targets.

Three navigational aids are used during entry and landing. The tactical air navigation (tacan) system determines the bearing and slant range from the Orbiter to a ground station (of known position with respect to the landing site) for fairly long ranges. The microwave scanning beam landing system (MSBLS) determines the elevation, azimuth angles, and range of the Orbiter from the landing site for fairly close ranges. The radar altimeter provides absolute altitude with respect to the runway from 762 meters (2500 feet) to touchdown. These navigational data are used to update the Orbiter computers during the landing phase.

¹A state vector is a mathematical representation of a vehicle's position in three-dimensional space and time (motion). The state vector is used for trajectory computations.

Communications

The Orbiter uses four separate communications systems: S-band PM, S-band frequency-modulated (FM), Ku-band, and ultrahigh frequency (uhf). The S- and Ku-bands are microwave systems. The S-band PM and Ku-band systems provide for the transmission and reception of voice, engineering and scientific data, and commands. The Ku-band provides for television transmission to the ground. The S-band FM equipment provides for the transmission of engineering and scientific data and television. The S-band payload system provides for sending voice and commands to detached payloads and receiving voice and data from detached payloads. The uhf system provides two-way (amplitude-modulated) voice for air-to-ground, orbital, and extravehicular astronaut communications. A hardwired audio system provides communications from point to point within both the Orbiter and the payload bay. Closed-circuit television is provided by cameras on the remote manipulator system (RMS) to aid in RMS control and by fixed cameras in the payload bay for observation of payloads.

Displays and Controls

The Orbiter displays and controls subsystem allows the crew to supervise, control, and monitor all Orbiter systems. It includes the display and control panels, the spacecraft and RMS hand controllers, the cathode-ray-tube displays, the keyboards and associated electronics, the timing displays, the caution-and-warning (C&W) system, and the spacecraft lighting. It also provides caution-and-warning and status information on the ET, SRB's, and payload systems.

Multifunction Display System

The multifunction display system consists of a keyboard unit for manual control and data entry, a television display unit that displays alphanumeric and graphic information on a 12.7- by 17.8-centimeter (5- by 7-inch) screen, and a display electronics unit that stores and processes display data. Two keyboards are located in the forward flight station for use by the pilot and the crew commander and a third is located in the aft mission station for use by the mission and payload specialists. Three television display units are also located in the forward flight station with a fourth in the mission specialist station.

Electrical Power Distribution And Control

The electrical power distribution and control subsystem controls, conditions, and distributes electrical power throughout the vehicle. The power system can be controlled through Orbiter avionics and is capable of performing specified power switching and sequencing of devices that must operate in a time-critical priority sequence. It also provides power to attached payloads.

Engine Interface Unit

The engine interface unit provides a two-way redundant digital interface for main engine commands. Each of the three engine interface units connects the main computers with the three Space Shuttle Main Engine (SSME) controllers. Main engine functions such as initiation, ignition, gimbaling, thrust throttling, and shutdown are internally controlled by the main engine controller through inputs from the guidance equations computed in the Orbiter general-purpose computers.

Payload Data Interleaver

The distinguishing characteristic of payload data is that it will not necessarily be standardized for Orbiter computers. To accommodate the various forms of payload data, the payload data interleaver integrates payload data into the Orbiter avionics so that the data can be transmitted to the ground. This applies to attached payloads; free-flying satellites are expected to have independent data transmission systems.

Data Processing

The Orbiter data processing subsystem handles data processing, data transfer, data entry, and data display in conjunction with the operations of the Orbiter avionics systems. The data processing system consists of the following.

1. Five general-purpose computers for computation and control
2. Two magnetic-tape mass memories for large-volume bulk storage
3. Time-shared serial-digital data buses (essentially party lines) to accommodate the data traffic between the computers and other Orbiter subsystems
4. Nineteen multiplexer-demultiplexer units to convert and format data at various subsystems
5. Three remote engine interface units to command the Orbiter main rocket engines
6. Four multifunction television display systems for the crew to monitor and control the Orbiter and payload systems

General-purpose computer.—Each general-purpose computer is a modified IBM AP-101 microprogram-controlled computer. The computer has a 106 496-word (36 bits to the word) memory. The Apollo command module computer had a central memory of 38 912 words (16 bits to the word).

As part of the fail-safe design of the avionics system, four of the five computers are arranged as a redundant group during critical flight operations such as launch/ascent or entry/landing. In this mode, the four computers are linked as a voting set, with each one capable of being used as the flight control computer and with each one checking on the other three. The crew can select which of the four computers is in control. The fifth computer is used for the backup flight control system, which would control the Shuttle should all four voting computers fail.

Each of the four computers in the redundant set synchronizes itself to the other three computers 440 times each second. In this way, the computer set is able to achieve a high degree of reliability. During noncritical flight periods, one computer is

used for guidance, navigation, and control tasks and another for systems management. The remaining three can be used for payload management or can be deactivated.

During critical phases of a mission, each of the five computers in the system performs approximately 325 000 operations each second using floating-point arithmetic. The crew can ask more than 1 000 questions of the system and have information displayed as alphanumeric symbols, as graphs, or as a combination of the two (including moving and flashing characters or symbols) on any of the four television display sets.

Main memory.—In addition to the central memory stored in the computers themselves, 34 000 000 bits of information are also stored in two magnetic-tape devices. Critical programs and data are loaded in both tape machines and are protected from erasure. Normally, one mass memory unit is activated for use and the other is held in reserve for operation if the primary unit fails. However, it is possible to use both units simultaneously on separate data buses or to have both communicate with separate computers.

Data bus.—The data bus network consists of digital data signal paths between the computers and the avionics subsystems and secondary channels between the telemetry system and the units that collect instrumentation data. This system is also fail-safe.

The data transfer technique uses time-division multiplexing with pulse-code modulation. In this system, data channels are multiplexed together, one after the other, and information is coded on any given channel by a series of binary pulses corresponding to discrete information. Twenty-four data buses are on the Orbiter and an additional 28 buses connect the Orbiter avionics with the Solid Rocket Boosters and the External Tank.

Multiplexer-demultiplexer.—The multiplexer-demultiplexer units are used in numerous remote locations of the Orbiter to handle the functions of serial data time multiplexing-demultiplexing associated with the digital data buses and for signal conditioning. They act as translators, putting information on or taking it off the data buses.

Master timing unit.—All Orbiter and payload data are time-tagged with coordinated universal time and mission-elapsed time generated by the master timing unit. This device also supplies synchronizing signals to other electronic circuits as required and to the computers.

Data Processing Software

The software stored in and executed by the Orbiter general-purpose computers is the most sophisticated and complex set of programs ever developed for aerospace use. The programs are written to accommodate almost every aspect of Shuttle operations including vehicle checkout at the manufacturer's plant; flight turnaround activity at the Kennedy Space Center; prelaunch and final countdown; and navigation, guidance, and control during the ascent, orbital, entry, and landing phases and during abort or other contingency mission phases. In-flight programs monitor the status of vehicle subsystems; provide consumables computations; control the opening and closing of payload doors; operate the remote manipulator system; perform fault detection and annunciation; provide for payload monitoring, commanding, control, and data acquisition; provide antenna pointing for the various communications systems; and provide backup guidance, navigation, and control for the ascent, orbital, entry, and landing phases and for aborts.

These primary computer programs are written so that they can be executed by a single computer or by all computers executing an identical program in the same time frame. This multicomputer mode is used for critical flight phases such as launch, ascent, entry, and aborts.

The Orbiter software for a major mission phase must fit into the 106 496-word central memory of each computer. To accomplish all the computing functions referred to (for all phases) would require approximately 400 000 words of computer memory. To fit the software needed into the computer memory space available, computer programs have been subdivided into nine memory groups corresponding to the functions executed during specific flight and checkout phases. For example, one memory group accommodates final countdown, ascent, and aborts; another, orbital operations; and yet another, the entry and landing computations. Different memory groups support

checkout and turnaround operations and systems management functions. Orbiter computers are loaded with different memory groups from magnetic tapes containing the desired programs. In this way, all the software needed can be stored in mass memory units (tape machines) and loaded into the computers only when actually needed.

Software architecture.—The Orbiter computer programs are written in a hierarchy that contains two levels.

The first level is the system software group, which consists of three sets of programs: (1) the flight computer operating program (the *executive*), which controls the processors, monitors key system parameters, allocates computer resources, provides for orderly program interrupts for higher priority activities, and updates computer memory; (2) the user interface program, which provides instructions for processing crew commands or requests; and (3) the system control program, which initializes each computer and arranges for multicomputer operation during critical flight periods. The system software group programs also tell the computers how to perform and how to communicate with the other equipment.

The second level of memory groups is the applications processing software. This group contains specific software programs for guidance, navigation, and control; systems management; payload operations; and vehicle checkout. The two program groups are combined to form a memory configuration for a specific mission phase. The guidance, navigation, and control programs contain functions required for launching, flying into orbit, maneuvering on orbit, and returning to an Earth landing. The systems management programs handle data management, performance monitoring, and special and display control processing. The payload processing programs contain instructions for control and monitoring of Orbiter payload systems. This set of instructions can be revised depending on the nature of the payload. The vehicle checkout program contains instructions for loading the memories in the main engine computers and for checking the instrumentation system. This program also aids in vehicle subsystem checkout and in ascertaining that the crew displays and controls perform properly. It is also used to update inertial measurement unit state vectors.

Programming.—Coding of the Orbiter software programs is accomplished in the same manner as for the general-purpose ground-based computers. In general, the operating system programs are coded in basic assembly language. Applications programs (e.g., the guidance, navigation, and control software) are written using high-order languages (such as the IBM FORTRAN series). In Orbiter computers, the operating system *executive* is coded in assembly language. The remaining two operating system programs and all four applications programs are written in HAL/S, a high-order language especially developed for NASA to be used in real-time space applications. It uses a base that is oriented toward the mathematics employed in guidance and navigation algorithms (detailed logical procedures for solving problems).

GUIDANCE, NAVIGATION, AND CONTROL

Guidance, Navigation, and Control Systems

The Orbiter is a combination launch vehicle, space orbiter, and atmospheric glider. Several discrete systems provide inputs to the general-purpose computers to guide the vehicle through its trajectory in any of the different flight modes. The computers use a program called the flight control module to control the Orbiter through the launch, ascent, orbit, deorbit, and landing phases. The program operates with inputs from the guidance, navigation, redundancy management, and display interface processor programs. The guidance, navigation, and control system is composed of the four Orbiter computers and

other major components that make up the primary flight control system (fig. 4-15). The fifth Orbiter computer is used for the backup flight control system but has no guidance or navigation computational ability. During launch, most of the computer commands are directed to the gimbaled main engines and the Solid Rocket Boosters. In orbit, the flight control commands are directed to the reaction control system and the vernier steering engines. In orbit and during deorbit, the computer directs the orbital maneuvering engines. During the reentry and landing phases, the computer output directs the Orbiter aerodynamic control surfaces (the left and right inboard and outboard elevons, the speed-brake/rudder assembly, and the body flap) in what is known as the "fly-by-wire" mode.

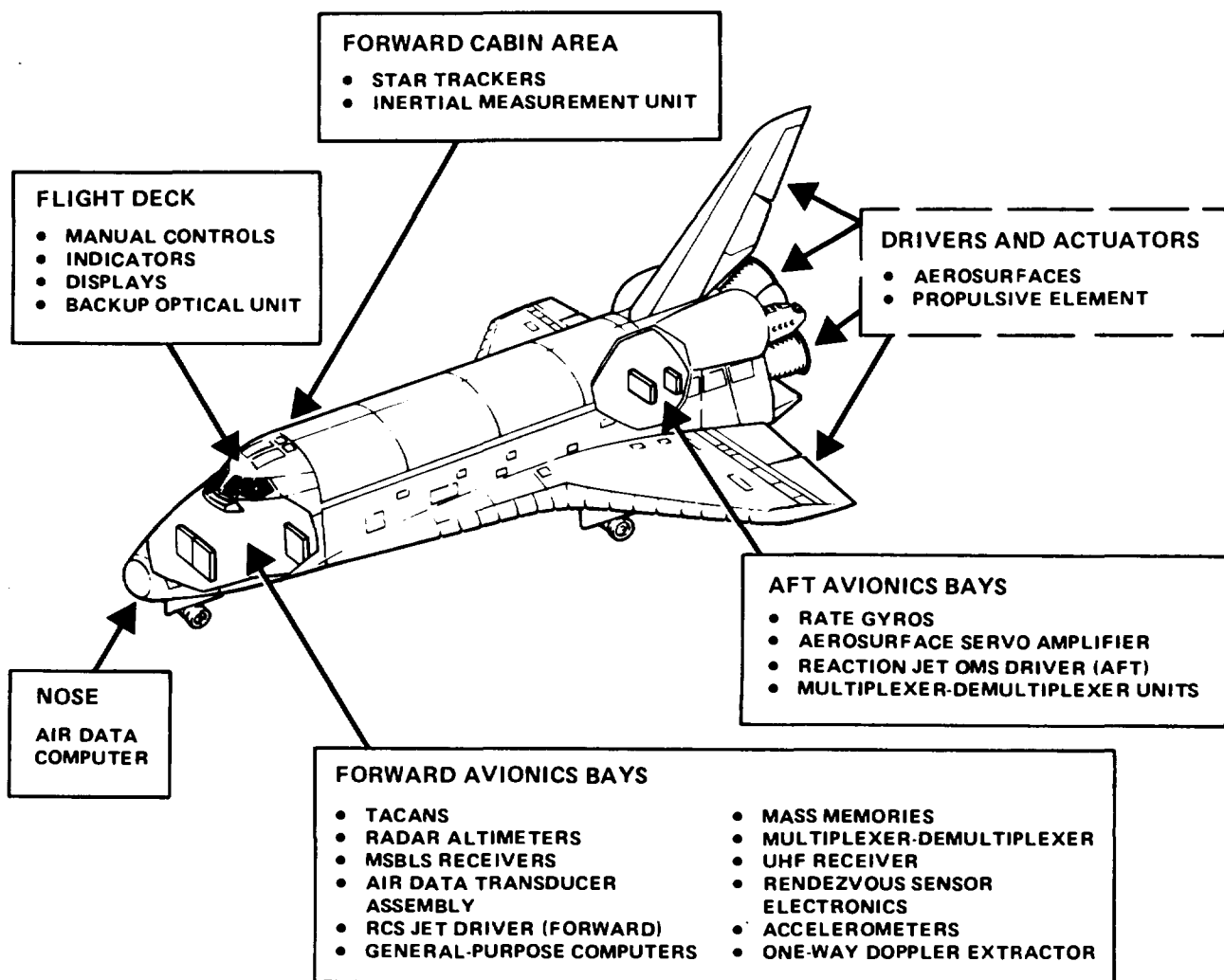

Figure 4-15.—Orbiter guidance, navigation, and control system.

The Orbiter commander or pilot can select the flight control system operation mode and the flight control program associated with the particular flight phase the Orbiter is in at that time. There are three modes of flight control: automatic, where the computer system flies the vehicle; control stick steering, where the flightcrew flies the vehicle with computer augmentation; and direct, where the flightcrew flies the vehicle with no augmentation. The flightcrew can also select separate rates for pitch, roll, and yaw, the speed brake, and the body flap.

In the automatic flight control mode, the flightcrew monitors the instruments to verify that the spacecraft computing system is following the correct trajectory. The guidance, navigation, and control system computes the flight control equations that command the movement of the spacecraft. If the spacecraft diverges from the proper trajectory, the flightcrew can take over at any time by switching modes to control stick steering or direct. The spacecraft has the ability to fly to a landing in the automatic mode—only landing gear extension and braking are performed by the crew.

In the control stick steering mode, the crew flies the spacecraft by operating a small pistol-grip stick called a rotational hand controller (RHC) and, if in aerodynamic flight, the rudder pedals. The flight control system interprets the RHC motions as rate commands in pitch, roll, and yaw. The larger the hand motion, the larger the command. The flight control system compares these commands with inputs from rate gyros and accelerometers that indicate what the vehicle is actually doing and then generates control signals to produce the desired rates in each axis. If the flightcrew releases the hand controller, it will return to center and the spacecraft will maintain the attitude it was in at the moment of RHC release.

In the direct mode, the spacecraft responds only to inputs from the flightcrew, although the commands are still run through the computers. The pilot must coordinate turns, damp out oscillations, and maintain attitude.

Navigation Aids

A number of systems are used in orbit and in atmospheric flight to provide both the Orbiter computers and the crew with position information.

Inertial/optical subsystem.—The inertial/optical subsystem consists of three inertial measurement units (IMU's) and two star trackers mounted on a rigid interconnecting structure called a navigation base. The IMU's provide attitude and velocity state information with respect to a known inertial coordinate reference. The star tracker function is to periodically correct the IMU attitude errors, which diverge because of characteristic drift rates in the inertial components. The IMU's and the star trackers are redundant. Controlled stability of the IMU and star tracker mounting reference points is required for orbital alignment and redundancy management and is achieved by the rigid design of the navigation base structure.

The inertial measurement unit provides the Orbiter with velocity components used by the guidance and navigation subsystem for all phases of the Orbiter mission. In addition, attitude information is provided to the Orbiter autopilot system.

Three identical and functionally independent IMU's are provided on each Orbiter. The IMU system software provides hardware control, calibration, alignment, and redundancy management.

The star tracker is a strapped-down wide-field-of-view image dissector electro-optical tracking device. The major function of the star tracker is to search for, acquire, and track selected navigation stars. From data thus obtained, the Orbiter attitude is calculated and the IMU's can be aligned. A secondary function of the star tracker is to acquire and measure angular data from the Orbiter to a target vehicle.

The star tracker is used to determine the actual attitude of the Orbiter by measuring the angles to two stars (ideally approximately 90° apart) as “seen” from the center of the Earth (mean of 1950). At the time of angle measurement, the IMU angles and rates are recorded and stored. By comparing the star tracker angles to the IMU-measured attitude angles, error values can be determined. These errors are used to realine or correct the IMU attitude.

Accelerometer assemblies.—There are four body-mounted accelerometer assemblies onboard the Orbiter mounted in the forward avionics bay. Each assembly contains two single-axis accelerometers positioned such that one senses lateral accelerations and one senses normal accelerations. Lateral accelerations are sensed along the Y-axis and normal accelerations are sensed along the Z-axis.

Lateral and normal accelerations from the accelerometer assemblies are used in flight control for stability augmentation and command signal limiting for the yaw and pitch axes, respectively. Normal acceleration is also compared with the guidance normal acceleration command when the automatic flight control system mode is engaged.

Rate gyro assemblies.—The Orbiter is equipped with four rate gyro assemblies (RGA's) located on the aft bulkhead. RGA 1 and RGA 2 are located on the left and right sides of the bulkhead facing the aft end of the Orbiter; RGA 3 and RGA 4 are located side by side at the bottom of the bulkhead in the wing well facing the payload bay. In addition, each Solid Rocket Booster is equipped with three rate gyro assemblies.

Each assembly consists of three single-degree-of-freedom rate gyros positioned to sense rates about the pitch, roll, and yaw body axes. All the assemblies contain identical gyros. The only difference between a roll gyro, a pitch gyro, and a yaw gyro is the manner in which each is positioned within the assembly. The Orbiter RGA's send the sensed pitch, roll, and yaw rates to flight control where the sensed rates act as damping feedback that contributes to stability augmentation of the vehicle. The Orbiter rate gyros are operational during the ascent and entry flight phases but are turned off during the orbital flight phase.

The two Solid Rocket Boosters each have three rate gyro assemblies. Each SRB assembly contains two single-degree-of-freedom rate gyros, one positioned to sense pitch rates and the other positioned to sense yaw rates. The SRB rate gyro assemblies are mounted on the forward ring within the forward skirt of the SRB attach point.

Air data system.—The primary air data system consists of two probes, one on the left side and one on the right side of the Orbiter forward fuselage. Each has its own deployment and stowage system.

Each probe senses four pressures at ports on each probe. Static pressure is sensed at the side, total pressure at the front, angle of attack/upper at the near top front, and angle of attack/lower at the near bottom front.

The pressure and temperature data are directed into four air data transducer assemblies. The signals go to a digital processor for error correction and are then routed to the general-purpose computers. After processing, the angle of attack, altitude, altitude rate, equivalent air speed, and Mach number/velocity are displayed on indicators in front of each crewmember. These data are also used in the automatic guidance, navigation, and control computer programs.

Tacan.—The tactical air navigation (tacan) is an external navigation aid in the Orbiter. There are three L-band antennas on the upper part of the Orbiter forward fuselage and three on the bottom part. Three tacan sets are located in the Orbiter crew compartment (mid-deck avionics bays 1, 2, and 3). Connected to each tacan set is one upper and one lower L-band antenna.

The three tacan sets operate simultaneously with one of the 126 L-band channels and have near-omnidirectional antenna coverage. The upper and lower L-band antennas are selected automatically by the tacan or by the flightcrew. The three tacan transmitters/receivers provide output data to the computers. The computers then drive the two horizontal situation indicators on the control panel for range and bearing information.

Microwave scan beam landing system.—The microwave scan beam landing system (MSBLS) will provide highly accurate three-dimensional position information to the Orbiter to compute steering commands to maintain the spacecraft on the nominal flight trajectory during the landing phase, beginning approximately 15 kilometers (8 nautical miles) from the runway at Edwards Air Force Base in California or the Kennedy Space Center in Florida.

The Orbiter landing system is composed of three independent MSBLS sets. Each set consists of a Ku-band antenna, a radiofrequency assembly, and a decoder assembly. Each Ku-band transmitter/receiver, with its decoder and data computation capabilities, determines the elevation angle, the azimuth angle, and the range of the Orbiter with respect to the MSBLS ground station.

The Orbiter MSBLS initially acquires the ground station while the Orbiter is on the heading alignment circle at an altitude of approximately 4300 meters (14 000 feet). Final tracking occurs at the terminal area energy management (TAEM)/automatic landing interface at approximately 3000 meters (10 000 feet) and 15 kilometers (8 nautical miles) from the MSBLS ground station. Angle (elevation and azimuth) and range data from the MSBLS are used by the guidance, navigation, and control system from acquisition until the Orbiter is over the runway approach threshold at an altitude of approximately 30 meters (100 feet). From this point to touchdown, radar altitude provides elevation (pitch) guidance.

Radar altimeter.—The radar altimeter is a low-altitude terrain-tracking altitude-sensing system. The altimeter logic is based on the precise measurement of time required for a radar pulse to travel to the nearest object on the ground below and return to the Orbiter. The radar altimeter is used for precision touchdown guidance after the Orbiter has crossed the runway threshold. It acquires and tracks the ground during the final 762 meters (2500 feet) of descent. The altimeter will be the primary sensor controlling the automatic landing system after the Orbiter crosses the runway threshold. Accurate high-resolution tracking is maintained at altitudes from 0 to 762 meters (0 to 2500 feet).

Backup flight control system.—The backup flight control system is distinct from the primary guidance, navigation, and control flight control system and is used only in extreme emergencies. The backup system uses control equations similar to those used by the primary flight control system. The fifth general-purpose computer is used exclusively for the backup flight control system.

The backup system is limited to a single flight control system to avoid generic problems that may exist with the four primary computers or primary flight control system software. The functions of this system are flight control and collection of air data measurements from an independent air data computer.

The backup system uses the fifth computer, a dedicated multiplexer-demultiplexer set for input data collection, and dedicated and shared sensing devices. The existing aerosurface servoamplifiers, servoactuators, and actuators are retained in their redundant form from the primary flight control system. No cathode-ray-tube/keyboard operation is used. Minimal interface is required between the primary and backup systems and is necessary only for switchover and sharing of common hardware.

The backup flight control system operates concurrently with the primary flight control system, processing the same command, sensor, and surface position feedback data; however, its outputs are inhibited unless the backup system is activated.

DISPLAYS AND CONTROLS

The cockpit of the Orbiter contains the most complicated assortment of displays and controls ever developed for an aerodynamic vehicle. To ensure that the commander and pilot acquire a blind sense of location and feel for the vehicle controls, the displays and controls exist in a variety of configurations. The switches are toggle, push, and horizontal and vertical rotary types. Meters are circular dial, square dial, and square tape types. Switches and circuit breakers are positioned in groups corresponding to their function.

There are more than 2020 displays and controls in the forward and aft cockpit and mid-deck sections of the Orbiter. A breakdown of this number, which represents more than 100 times the number of controls and displays found in the average automobile, is given in table 4-1.

Orbiter displays and controls consist of panel displays, mechanical controls, and electrically operated controls. Generally, the displays and controls are grouped by function and arranged in operational sequence from left to right or top to bottom with the most critical and most frequently used devices located so as to maximize crew performance and efficiency. All controls are protected from inadvertent activation. All displays and controls are provided with dimmable floodlighting in addition to being backlit.

The displays and controls are divided between the forward flight station and the mission specialist station. The forward station contains all the equipment necessary for the operation of the Orbiter. The mission specialist station contains the auxiliary displays and controls necessary for rendezvous and docking and for controlling the remote manipulator system and the payload.

The forward flight control area panels are labeled "L" for the left (the commander's position), "R" for the right (the pilot's position), "F" for the front section, "O" for the overhead back position, and "C" for the lower center section.

The left panel contains circuit breakers, controls, and instrumentation for the environmental control and life-support system, the communications equipment, the heating controls, and the trim and body-flap controls. The commander's speed

TABLE 4-1.— ORBITER DISPLAYS AND CONTROLS BREAKDOWN

Display or control	Quantity
Toggle switches	827
Circuit breakers	430
Pushbutton switches	415
Rotary switches	53
Thumbwheel switches	29
Timers	4
Vernier potentiometers	97
Rotational hand controllers	3
Translational hand controllers	2
Crew optical alignment sight	1
Meters (round, tape, straight)	88
Event and mode lights	58
Horizontal situation indicator	2
Attitude direction indicator	2
Cathode-ray tube	4
Caution-and-warning panel (includes fire panel)	^a 3
Computer status board	^b 1

^a170 indicator lights.

^b25 indicator lights.

brake and thrust controller is on the left panel. The right panel contains more circuit breakers; controls for the fuel cells, hydraulic system, and auxiliary power units; and the pilot's communication controls. Electrical power distribution controls and development flight instrumentation are also located on the right-hand panels. The pilot's speed brake and thrust controller is to his left on the center console.

The overhead rack contains lighting controls, the computer voting panel, and fuel cell purge controls. The center console contains the flight control system channel selector, the air data computer equipment, and the communication and navigation control set. It also contains fuel cell circuit breakers and the pilot's trim and body-flap controls.

The center forward panel contains the three cathode-ray-tube display sets, the caution-and-warning system, aerosurface position indicators, backup flight control displays, and the fire protection system displays and controls. There are primary flight displays for both the commander and the pilot as well as auxiliary power unit and hydraulic displays and controls for the landing gear. The glare shield contains event lights to annunciate the flight control system modes.

The commander and the pilot each have a hand controller with integral switching to activate the backup flight control system. The jettison panel, used only for the orbital flight test phase, is located squarely in front.

The aft mission specialist station contains left, right, and center panels. The left panel contains ground operations controls for the hydraulic system and the auxiliary power units and a caution-and-warning panel. The right panel is available for plug-in units specific to payloads. The center panel contains controls for the payload bay, for payload bay services such as lighting and electricity, and for the remote manipulator system. Television camera controls are also located in the center panel.

Controls

Following is a brief description of the major controls.

Rotational hand controller.—The rotational hand controller provides manual command capability for thrust vector control. It provides three-axis control during orbital flight and two-axis control during aerodynamic flight. There is one control for each crewmember at the forward flight station and one at the onorbit station.

Translational hand controller.—The translational hand controller provides manual command capability for three-axis translation control during orbital flight. Two controllers are provided, one on the left side of the forward flight station and one at the onorbit station.

Rudder pedal transducer assembly.—The rudder pedal transducer assembly provides manual command capability for yaw rotation during aerodynamic flight. It consists of a set of triply redundant transducers mechanically linked on a common shaft to pedals at each forward flight station.

Speed brake/thrust controller.—The speed brake and the thrust controller are combined into one hand controller. It provides manual command capability for control of the Orbiter speed-brake surfaces during aerodynamic flight (except vertical launch) and for control of the Orbiter main propulsion thrust magnitude during vertical launch. A controller is located at each forward flight station.

Remote manipulator hand controller.—The remote manipulator hand controller is located at the onorbit station for manual command capability for moving the remote manipulator arm. It consists of a rotational controller and a translational controller.

Keyboard.—The keyboard is used to interface with the multifunction display subsystem and to manage information shown on the display unit. It also gives commands to the Orbiter computer system for execution. The keyboard consists of 32 keys with illuminated legends on each key. Three keyboards are provided, two in the forward flight station and one at the mission specialist station. Provision has been made to add another keyboard system at the payload specialist station if one is required for a particular payload.

Displays

The following paragraphs briefly describe the major Orbiter displays.

Attitude direction indicator.—The attitude direction indicator (ADI) provides a simultaneous display of roll, pitch, and yaw attitude angles, attitude error, and attitude angular rates. The attitude indicator is used as a three-axis indicator for space flight and as a two-axis (roll and pitch) indicator for aerodynamic flight. Vehicle attitude is displayed by a gimballed ball, attitude errors by three meter-positioned needles, and attitude rates by three meter-positioned pointers. Three attitude direction indicators are provided, two in the forward flight station and one at the onorbit station.

Surface position indicator.—The surface position indicator (SPI) displays the position of the various aerodynamic control surfaces: the left outboard elevon, the left inboard elevon, the right inboard elevon, the right outboard elevon, the rudder, and the body flap. The surface position indicator is a panel-mounted electronic indicator unit and is located in the forward flight station.

Alpha/Mach indicator.—The alpha/Mach indicator (AMI) provides displays of the angle of attack (alpha), the acceleration, the Mach number/velocity, and the equivalent airspeed in knots. The parameters are displayed on moving tapes behind a fixed lubber line or by a combination of a fixed scale, a moving pointer, and a moving tape. Two alpha/Mach indicators are provided in the forward flight station.

Altitude/vertical velocity indicator.—The altitude/vertical velocity indicator (AVVI) provides a display of altitude acceleration, altitude rate, altitude, and radar altitude on a fixed scale with a moving pointer or on moving tapes behind a fixed lubber line. Two AVVI's are provided in the forward flight station.

Accelerometer indicator.—The accelerometer indicator (g-meter) provides an indication of the acceleration imposed along the Z-axis of the Orbiter. The g-meter is a panel-mounted mechanical unit. It consists of a single pointer attached to a rack-and-pinion coupling mechanism that is actuated by a constant-rate helical spring and a magnetic drag cup damping device. One g-meter is provided in the forward flight station.

Horizontal situation indicator.—The horizontal situation indicator (HSI) provides a display of vehicle position in relation to preselected navigational waypoints. The vehicle heading is displayed on the compass card. The bearing to the primary navigation point is displayed by the primary bearing pointer and the primary distance is displayed in the primary miles window. The bearing to the secondary navigation point is displayed by the secondary bearing pointer and the secondary distance is displayed in the secondary miles window. The preselected runway heading is displayed by the course arrow. The location of the extended runway centerline is displayed on the course deviation indicator. The vehicle position on the nominal glide slope is displayed on the glide-slope indicator. Two horizontal situation indicators are provided in the forward flight station.

Display unit.—The Orbiter display unit (DU) provides a display, by means of a cathode-ray tube, of flight computer information in the form of a display page; i.e., alphanumeric and vector information. Display pages are selected by the crew. Four display units are provided, three in the forward flight station and one at the mission specialist station. Provisions have been made for adding a fifth unit at the payload specialist station. Because the display units are independent, they can display different pages or receive different inputs simultaneously.

Computer status annunciator.—The computer status annunciator assembly provides a display of the general-purpose computer fault status of

each computer as determined by itself and/or other units of the operating set of computers. This unit is also referred to as the computer voting board. One annunciator assembly is provided in the forward flight station.

Fire warning annunciator.—The fire warning annunciator assembly provides annunciation of smoke detection in the crew compartment; in avionics bays 1, 2, and 3; and in the payload area. The signals are also transmitted to the caution-and-warning system, which then actuates the master alarm and a siren.

Event indicator.—The event indicator provides an indication of a discrete condition within a system being monitored. It is an electromechanical unit with a shutter that drops away from the front of the display. These indicators come in either two- or three-stage devices.

Electrical indicating meters.—The electrical indicating meters are of several types. Round scale meters are used to provide an indication of the electrical condition within the electrical power distribution system. Vertical scale meters provide indications of pressure, quantity, and temperature within various Orbiter subsystems. Tape meters are used to provide indications of pressure, quantity, and temperature within the main propulsion, hydraulic, and auxiliary power systems.

Propellant quantity indicator.—The propellant quantity indicator consists of three two-digit incandescent displays within a single enclosure that display the percent of fuel or oxidizer remaining in the orbital maneuvering system or reaction control system tanks.

Crosspointer indicator.—The crosspointer indicator (CPI) enables the crew to maintain a constant line-of-sight angular rate with a given target. One CPI is located at the onorbit station.

Rendezvous radar indicator.—The rendezvous radar indicator receives data from the Ku-band electronics and displays these data on two four-digit-plus-sign displays. Switches command the radar indicator to display range/range rate or azimuth/elevation information. One radar indicator is located at the onorbit station.

Caution-and-warning system.—The caution-and-warning (C&W) system alerts the Orbiter flightcrew of an out-of-tolerance system. The C&W system consists of an electronics unit, three master-alarm pushbutton indicators, 40 C&W annunciator lights on the forward flight-deck display and control console, and 120 C&W status lights on the aft flight-deck C&W display and control panel. The C&W system has two modes of operation that are controlled by the CAUTION/WARNING switch located on the forward flight-deck display and control panel. When this switch is positioned to NORMAL, a C&W light will illuminate if its corresponding parameter exceeds its limit and will remain illuminated until the out-of-tolerance condition is corrected. In the case of an out-of-tolerance condition in the computer software, the corresponding C&W light and the blue S/M (systems management) ALERT light will illuminate and remain illuminated until the out-of-tolerance condition is acknowledged by the flightcrew by use of the computer keyboard. When a C&W light is illuminated, the three red MASTER ALARM pushbutton light indicators illuminate simultaneously and an audible tone is sounded in the headsets of the flightcrew. The audible tone in the headset will be an alternating tone if it comes from the C&W system or a continuous tone if it comes from the computer software. The applicable audible tone in the headset can be silenced and the red MASTER ALARM light can be extinguished by depressing the MASTER ALARM pushbutton light indicator.

Mission and event timers.—A mission timer (MT) and an event timer (ET) are provided in the forward flight station and in the onorbit station. The mission timer displays mission-elapsed time (MET) or Greenwich mean time (GMT) in days, hours, minutes, and seconds. The event timer is a four-digit display of minutes and seconds and is controlled by a set of external switches that set the timer, start and stop the display, and mode the display to count up or down.

COMMUNICATIONS AND DATA SYSTEMS

The communications and data systems provide flexible systems with adequate capability to accommodate the operational and scientific requirements of the wide range of Space Shuttle payloads.

The Orbiter systems (fig. 4-16) consist of radiofrequency systems, a general-purpose computer system, special processors for interfacing between payloads and radio-frequency systems, a television system, and tape recording systems. The supporting ground systems include the Ground Space Tracking and Data Network (GSTDN), the Tracking and Data Relay Satellite System (TDRSS), the Mission Control Center (MCC), and the Payload Operations Control Centers (POCC's).

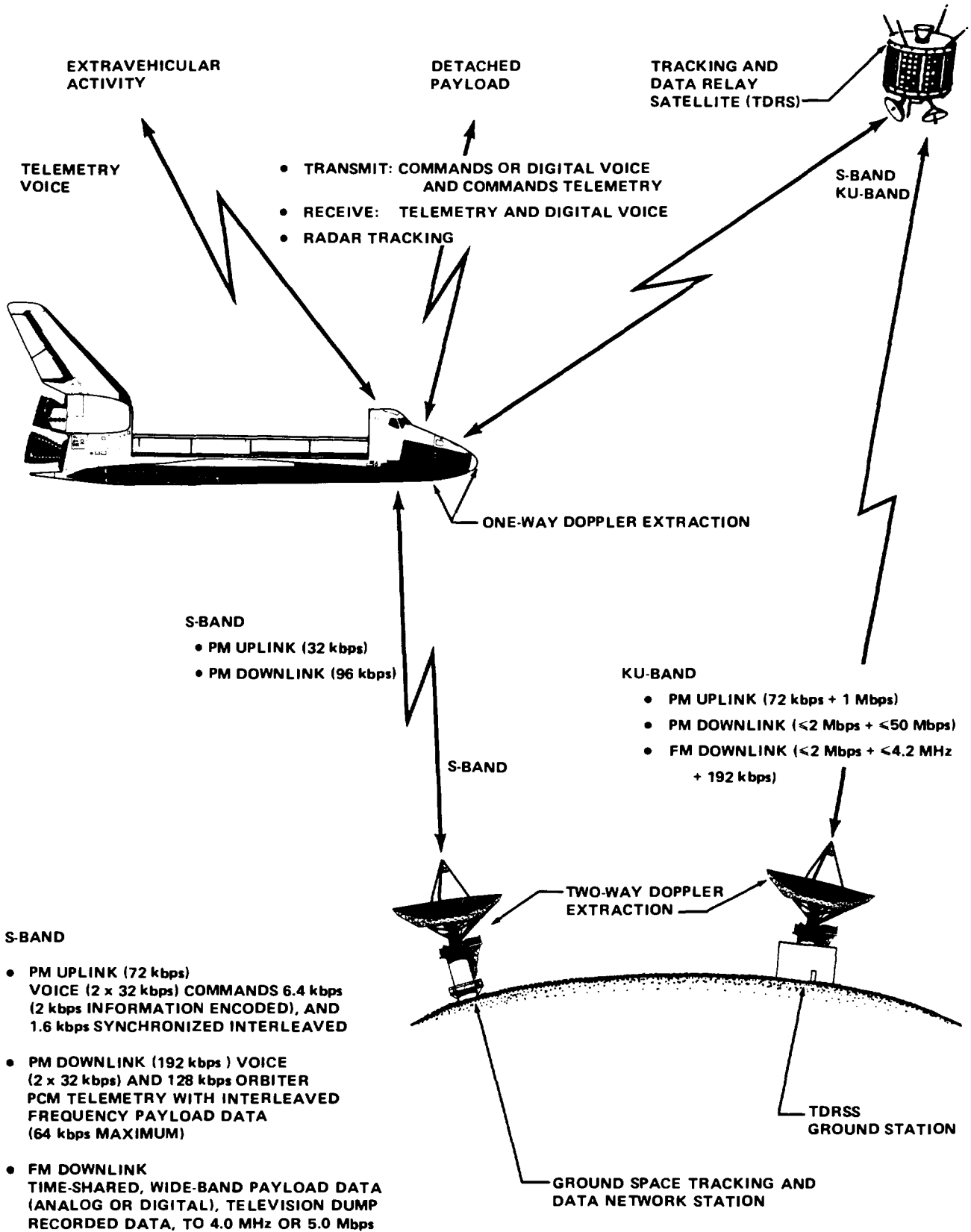

Figure 4-16.— Space Shuttle orbital communications and tracking links.

Orbiter Radiofrequency Systems

The Orbiter radiofrequency (rf) systems and data services are summarized in table 4-II. Included are an S-band phase modulation (PM) transmitter/receiver, a Ku-band transmitter/receiver, two independent S-band FM transmitters, an S-band payload interrogator transmitter/receiver, and a Ku-band rendezvous radar.

S-band PM systems.—The S-band PM transmitter/receiver normally operates in phase lock with the uplink carrier. The system can operate on either of two sets of frequencies. The antenna system consists of four selectable omnidirectional antennas, one located in each quadrant of the Orbiter. One mode of the system is compatible with the ground tracking system and the other mode is compatible with the satellite tracking system.

TABLE 4-II.— ORBITER RADIOFREQUENCY SYSTEMS AND DATA SERVICES

System and frequency	Data services
S-band PM transmitter/receiver	
Transmitter - coherent: 240/221 times received frequency; auxiliary oscillator: 2287.5 or 2217.5 MHz	High data rate at 192 kbps: 2 voice at 32 kbps each 1 telemetry at 128 kbps Low data rate at 96 kbps: 1 voice at 32 kbps 1 telemetry at 64 kbps Ranging: turned-around composite signal on 1.7 MHz subcarrier
Receiver - 2106.406300 or 2041.947900 MHz	High data rate at 72 kbps: 2 voice at 32 kbps each 1 command at 8 kbps Low data rate at 32 kbps: 1 voice at 24 kbps 1 command at 8 kbps Ranging: composite signal on 1.7 MHz subcarrier
Ku-band transmitter/receiver	
Transmitter - 15.0034 GHz	Mode 1 (PM): 192 kbps operational data 16 kbps to 2 Mbps payload data or 60 to 1024 kbps operational playback data 2 to 50 Mbps payload data convolution-encoded at one half Mode 2 (FM): 192 kbps operational data 16 kbps to 2 Mbps payload data or 60 to 1024 kbps operational playback data 16 kbps to 4 Mbps PCM data or DC to 4.5 MHz analog data
Receiver - 13.7750 GHz	High data rate at 216 kbps: 1 command at 8 kbps 2 voice at 32 kbps each 1 text and graphics at 144 kbps

The S-band PM transmitter accepts real-time operational data at either of two rates: 96 or 192 kilobits per second (kbps). The low data rate consists of 64 kbps of telemetry and one 32-kbps digital voice channel; the high data rate consists of 128 kbps of telemetry and two digital voice channels of 32 kbps each.

The data rate received by the S-band PM receiver is either 32 or 72 kbps. The 32-kbps rate consists of 8 kbps of command and a single 24-kbps voice channel; the 72-kbps rate consists of

8 kbps of command and two 32-kbps voice channels. The ground station mode, but not the satellite tracking mode, provides a ranging capability by modulation of multiple tones on a 1.7-megahertz subcarrier in the signal received from the ground station. The received subcarrier is routed to the transmitter and back to the ground station.

This S-band PM system is available for use in all phases of the mission and will be available on all flights of the Orbiter.

TABLE 4-II.— Concluded

System and frequency	Data services
S-band FM transmitter	
Transmitter 1 - 2250.0 MHz	Wideband data for one of following: Real-time engine data - 3 channels at 60 kbps each Real-time television Real-time attached-payload data up to 4 MHz (analog) or 5 Mbps (digital) 1 main engine data dump at 60 kbps (one rate at 16:1) 1 PCM telemetry dump at 128 kbps (one rate at 8:1) 1 PCM telemetry dump at 192 kbps (one rate at 5:1)
Transmitter 2 - 2205.0 MHz	Real-time PCM development flight instrumentation at 128 kbps Real-time 15 subcarrier channels
S-band payload interrogator	
Transmitter - 2025.8 to 2118.7 MHz	828 channels: 2 kbps maximum
Receiver - 2200.0 to 2300.875 MHz	830 channels: 16 kbps maximum to payload data interleaver Bent-pipe 4.5 MHz maximum
Ku-band rendezvous radar	Cooperative or passive mode Outputs: range, range rate, angle, and angle rate

Ku-band transmitter/receiver.—The Ku-band system provides duplex communications between the Orbiter and the Mission Control Center through the tracking satellite when antenna line of sight exists. The system uses a high-gain antenna deployable from inside the payload bay. Use of this system is limited to orbital operations when the payload bay doors are open.

The Ku-band transmitter accepts data in either of two modes with three channels of data in each mode. In the first mode, channel 1 provides 192 kbps of real-time operational data identical to the format transmitted by the S-band PM system in the high-data-rate mode. Channel 2 provides (1) real-time attached-payload data up to 2 megabits per second (Mbps), (2) playback of operational data from the record/playback system, or (3) playback of payload data from the record/playback system. Channel 3 provides real-time or playback attached-payload digital data at rates up to 50 Mbps.

In the second mode, channels 1 and 2 are the same as in the first mode but channel 3 provides (1) television video to 4.5-megahertz bandwidth, (2) attached- or detached-payload analog data to 4.5-megahertz bandwidth, or (3) attached- or detached-payload digital data up to 4 Mbps.

The Ku-band receiver link includes the same 72-kbps data described for the S-band PM system high-rate mode. Additionally, a capability is provided for a text and graphics channel at 144 kbps for a total received data rate of 216 kbps. The primary Ku-band system and the rendezvous radar system are partly integrated, with a common antenna and front-end electronics.

For Ku-band acquisition between the Orbiter and the tracking satellite, the broad-beam Orbiter S-band PM signal will be acquired by the tracking satellite and used to point the satellite high-gain Ku-band antenna. The Orbiter Ku-band antenna will then acquire and automatically track the satellite Ku-band signal.

S-band payload interrogator.—The S-band payload interrogator is a transmitter/receiver designed to communicate with detached payloads. The payload interrogator and its companion avionics packages will be available in the latter part of the orbital flight test program. The interrogator transmitter operates on any one of the selectable channels and carries command data to the detached payloads at rates up to 2 kbps.

S-band FM transmitter.—The S-band FM transmitter provides a single wide-band data channel from the Orbiter to the ground stations. Inputs to the transmitter are selectable and can be any of the following:

1. Real-time or playback main engine data consisting of three channels at 60 kbps each
2. Playback of operational or payload data at rates up to 1.024 Mbps
3. Real-time payload data up to 5 Mbps or 4-megahertz bandwidth
4. Television video

The transmitter uses one of the two omnidirectional antennas located on the upper and lower hemispheres of the Orbiter.

Orbiter Interface With RF Systems

The Orbiter data system interfaces with the rf systems through a series of special-purpose processors: the pulse-code-modulation (PCM) master unit, the network signal processor, the Ku-band signal processor, and the FM signal processor.

PCM master unit.—The PCM master unit accepts data from attached or detached payloads through the payload data interleaver, the Orbiter, the general-purpose computers, and the Spacelab and provides outputs of operational telemetry at both the 64- and 128-kbps rates. Software is provided through the mass memory system to change the output formats such that various mixes of payload and Orbiter systems data can be output.

Network signal processor.—The network signal processor accepts inputs of 64- and 128-kbps operational data from the PCM master unit and analog voice data from the voice system. The voice is digitized and multiplexed with the operational telemetry and outputs are provided to the S-band PM transmitter, the recording system, and the Ku-band signal processor.

The command and voice data received through the Orbiter rf system are accepted by the network signal processor and demultiplexed. The voice data are converted to analog form and routed to the appropriate subsystems; the command data are routed to the Orbiter computers.

Ku-band signal processor.—The Ku-band signal processor accepts inputs from the network signal processor, the attached and detached payloads, the television system, and the record/playback systems and provides either of the two modes of three channels each that are transmitted by the Ku-band transmitter. The command, voice, and text/graphics data received by the Ku-band receiver are accepted by the Ku-band signal processor and routed to the appropriate subsystems.

FM signal processor.—The FM signal processor accepts inputs from the record/playback system, the television system, the main engines, and the payloads and selects the source to be transmitted by the S-band FM transmitter.

Orbiter Interface With Payload Data Systems

The Orbiter interfaces with payload data systems through two special-purpose processors, the payload signal processor and the payload data interleaver.

Payload signal processor.—The payload signal processor serves as an interface between the payload and the payload interrogator for demodulation of data from detached payloads. The processor outputs command data to attached payloads and to the payload interrogator for transmission to detached payloads. Provision is made in mass memory for changing the processor configuration to handle different data streams and bit rates.

Payload data interleaver.—STS payload data will not always be formatted and standardized for Orbiter computers. Attached payload data is fed by the payload data interleaver into the avionics system for downlink to the ground. Free-flying payloads are expected to have independent data downlink systems.

Data Record/Playback Systems

Two 14-track recorders are provided with up to 80 minutes capacity each. Tape speeds of 15 to 305 cm/s (6 to 120 in/s) in 14 steps are available, although no more than 4 steps are available on any one mission. One recorder is assigned as the operations recorder and the other as the payload recorder.

Television System

A closed-circuit television system (fig. 4-17) is scheduled for use during orbital operations, including crew compartment activities and out-the-window observations. Typical examples of crew compartment activities are crew operations, hardware inspection, and experimentation; typical examples of out-the-window observations include the Earth, payloads, and Orbiter exterior observations.

The television system is composed of the camera, the power cable, the monitor, the monitor cable, the lens assemblies (a 6-to-1 25-millimeter zoom lens and a 3-to-1 9-millimeter wide-angle zoom lens), and the camera bracket. Also included are the video interface unit, console monitors, and a video tape recorder. The video tape recorder will be used for remote manipulator system operations.

Television operations involving ground commands and downlink are restricted to S-band coverage during the early flights. For later flights, the Ku-band downlink will also be available.

The onboard television system consists of a video switcher capable of receiving camera inputs from as many as 10 cameras. The various video camera outputs may be transmitted to Earth by S-band FM or Ku-band as well as switched to two onboard console television monitors. The basic Space Shuttle television camera is a monochrome system with changeable lens configurations that allow for various size lenses and for lenses that contain a field sequential color wheel. The capability exists for future addition of a video tape recorder.

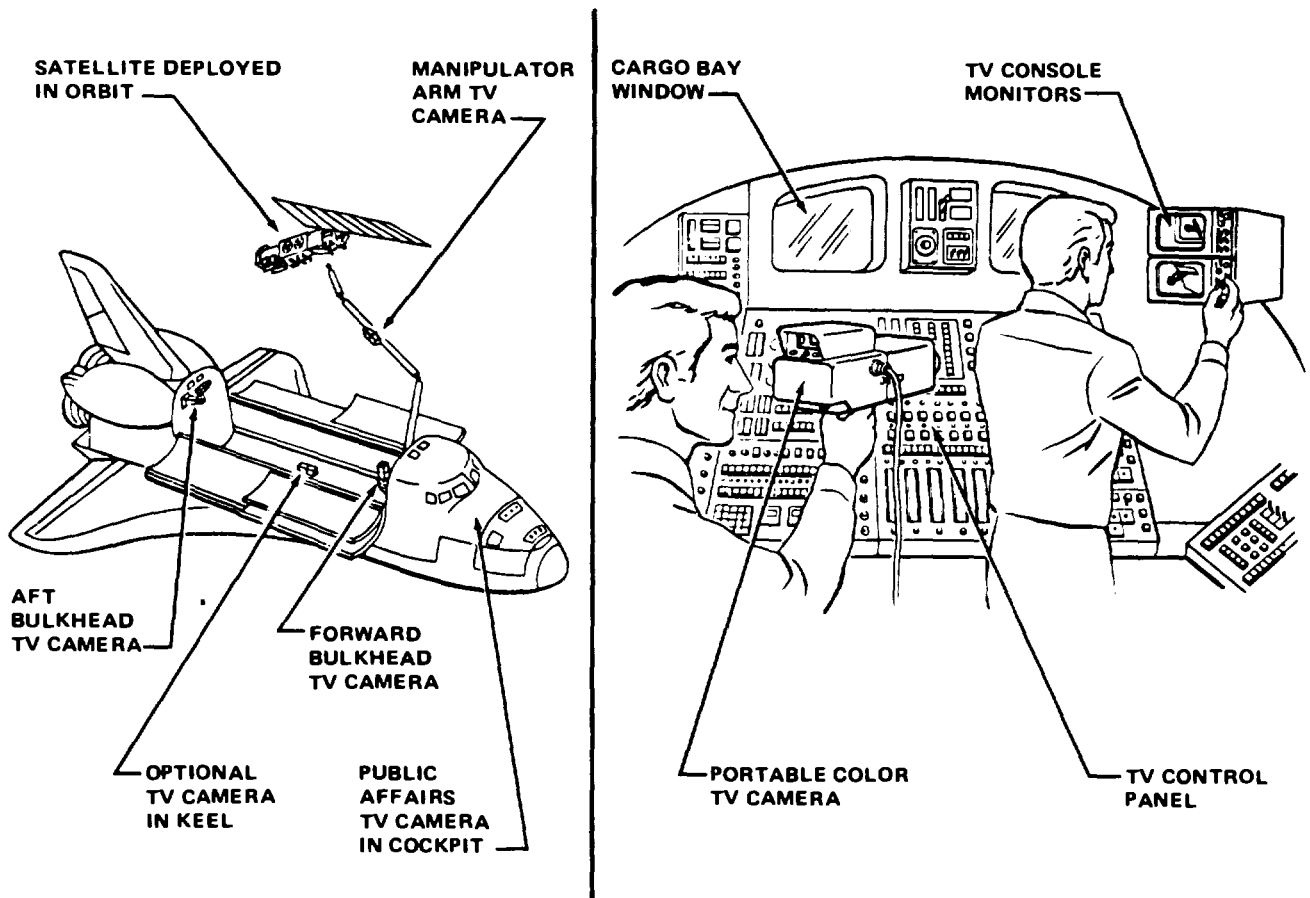

Figure 4-17.—Orbiter closed-circuit television system.

The television camera weighs approximately 7.3 kilograms (16 pounds). The camera has a bayonet lens mount to fit the lens assembly or the camera lens cover, which serves as a dust cover for protection of internal camera components. The top side, right side, and left side of the camera contain dovetail mounting rails to fit the camera bracket or the television monitor. The back of the camera contains the control panel and two connectors for the television power and monitor cables.

Tracking And Data Relay Satellite System

The tracking and data relay satellite system (TDRSS) will consist of two geosynchronous operational satellites separated by 130°, a third on-orbit spare satellite, and a single ground station. The ground station will be located at White Sands, New Mexico. The system will be a commercial service operated by Western Union. The TDRSS will be capable of supporting two Orbiters simultaneously and other Earth-orbital free-flying satellites in multi-access modes. It will also provide rf interfaces to the Orbiter Ku-band system and to the S-band PM system. At typical flight altitudes of 185 to 370 kilometers (100 to 200 nautical miles), the tracking satellite will typically provide communications for 40 to 90 percent of the day compared to a typical ground network communications contact of 7 to 30 percent of the day.

Ground communications.—Data from the tracking satellite ground station will be carried over two diversely routed duplex 1.544-Mbps lines. One will be routed to the Mission Control Center at the Johnson Space Center (JSC) through Goddard Space Flight Center (GSFC) and the other will go directly to the Mission Control Center. Some consideration has been given to expanding these services to 6.3-Mbps rates to accommodate limited payload streams. A single duplex 224-kbps line between GSFC and the Mission Control Center will be provided for backup communication. The ground station will provide a short-duration recording capability as protection for circuit outages.

Both real-time and playback operational telemetry will be transmitted in real time on both

circuits. Metric data and digital voice will be transmitted in addition to telemetry. Data from the Mission Control Center will include commands, digital voice, and digital text/graphics.

Domestic communications satellite services are envisaged for real-time remoting of high-data-rate payload data streams; video lines will be provided for remoting of mission television.

The GSFC-JSC communications links provided for the tracking satellite data will also be used for ground station data transmission.

Mission Control Center.—The Mission Control Center at the Johnson Space Center in Houston, Texas, will perform flight control. Additionally, the control center will provide for monitoring and control of specific payloads assigned to JSC. As the Space Shuttle becomes operational, the emphasis of the Mission Control Center will shift from basic systems monitoring to payload monitoring, mission management, and multiple flight support.

Payload Operations Control Centers.—Three Payload Operations Control Centers have been identified to interface with the Mission Control Center during the Space Shuttle Program: one at GSFC, one at the Jet Propulsion Laboratory, and one at JSC. The payload center at GSFC will be responsible for control of Earth-orbital free-flying payloads, the one at the Jet Propulsion Laboratory for control of deep-space payloads, and the one at JSC for control of Shuttle-attached payloads.

Telemetry.—Payload data interleaved in the Orbiter operational telemetry downlink will be routed to the Mission Control Center. The control center will process the data, extract the payload data, format it for output, and transmit it together with selected Orbiter data to the appropriate payload center. Ephemeris, command-verification, and ground-systems data will be transmitted with the telemetry data.

In addition to the interleaved data, some payloads will transmit directly to the ground or to satellite tracking systems; these data will be routed directly to the appropriate payload center.

Commands.—When payloads are attached to the Orbiter or are operating detached from the Orbiter through the payload interrogator link, commands from the payload centers will be formatted into the Orbiter command format and uplinked to the payload by the Orbiter systems. The control center will perform message error checks on payload center commands and provide command verifications to the payload centers.

Voice.—A capability to remote Orbiter-to-ground voice from the payload centers will be provided in coordination with the Mission Control Center use of this system. After completion of the Space Shuttle mission, deep-space and Earth-orbital free-flying payloads will be controlled from the appropriate payload center independent of the Mission Control Center.

Text and Graphics Hardcopy System

The text and graphics hardcopy system provides the crew with an onboard system for reproducing hardcopies of ground-generated data. These data include such information as crew activity plans, maneuver pads, general messages, schematics, photographs, crew procedures, and trajectory data.

The text and graphics hardcopy system is composed of a Polaroid camera system that provides a photographic copy of data displayed on an onboard television tube. A maximum of 100 pages of text data can be uplinked and stored in the Orbiter mass memory for television display and hardcopy. The system uses a 35-millimeter camera composed of a 35-millimeter television camera (including a 35-millimeter f/1.4 lens), a black-and-white Polaroid film pack, a 35-millimeter remote control cable, and a 35-millimeter camera bracket and hood.

For flight 17 and subsequent flights, the text and graphics hardcopy system will be a fiber optics system. The system hardcopies text and graphics data that are uplinked directly to the hardcopier. The 35-millimeter television camera system is dependent on S-band coverage for data uplink, whereas the hardcopier system relies on the Ku-band.

5. ORBITER CREW ACCOMMODATIONS AND EQUIPMENT



5. ORBITER CREW ACCOMMODATIONS AND EQUIPMENT

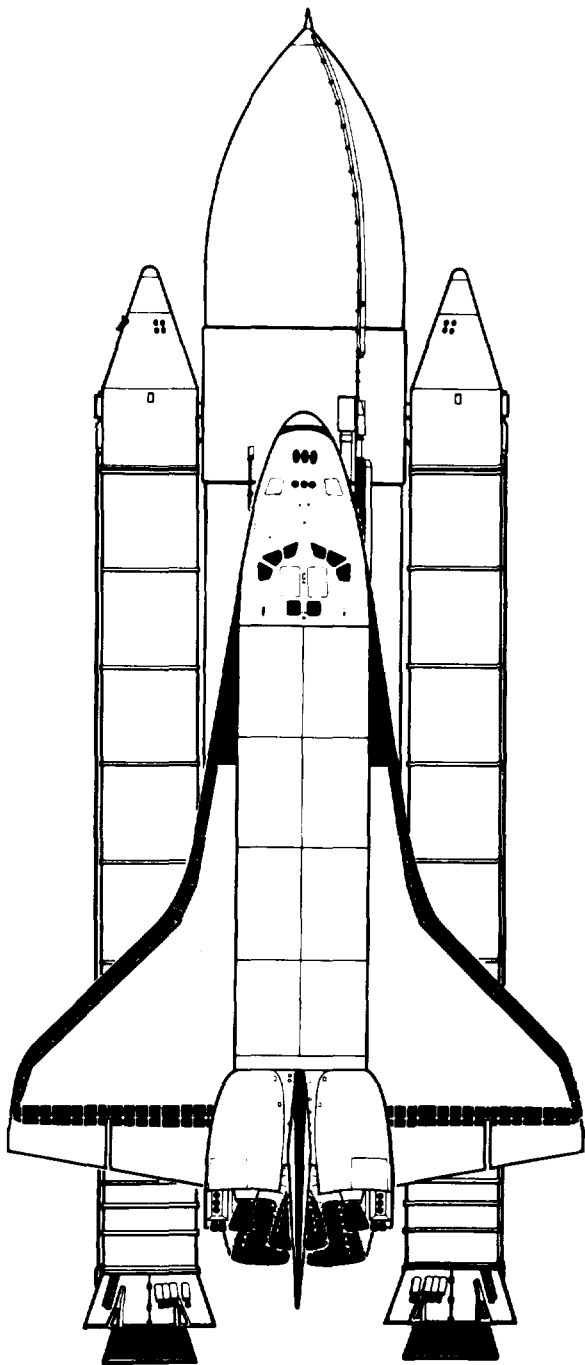

INTRODUCTION	5-5
Crew Station Configuration	5-5
Crew Schedule	5-6
Sleep	5-6
Meals	5-6
Other Activities	5-6
ORBITER ACCOMMODATIONS	5-7
Seats, Restraints, and Mobility Aids	5-7
Egress Provisions	5-11
Flight Data File	5-14
Sighting Aids	5-16
Photographic Equipment	5-18
Window Shades and Filters	5-18
Crew Equipment Stowage	5-20
Food System	5-21
Sleeping Accommodations	5-24
Waste Collection System	5-24
Personal Hygiene System	5-24
Housekeeping System	5-28
Orbiter Airlock	5-30
CREW EQUIPMENT	5-32
Shuttle Orbiter Medical System	5-32
Radiation Instrumentation	5-35
Operational Bioinstrumentation	5-36
Crew Equipment	5-37
Extravehicular Mobility Unit	5-38

PRECEDING PAGE BLANK NOT FILMED

Briefly . . .

The Orbiter's crew quarters are outfitted with everything from a galley for preparing balanced meals and bunks for sleeping to all the equipment needed for keeping house in space. The only time space suits will be worn is during space walks. The Orbiter has a medicine chest and equipment for emergency rescue or survival.

ORBITER ACCOMMODATIONS

Seats, restraints, and mobility aids
Egress systems
Flight data file
Sighting aids
Photographic equipment
Window shades and filters
Stowage areas
Food systems and equipment
Sleeping accommodations
Crew hygiene systems and accommodations
Housekeeping equipment
Airlock

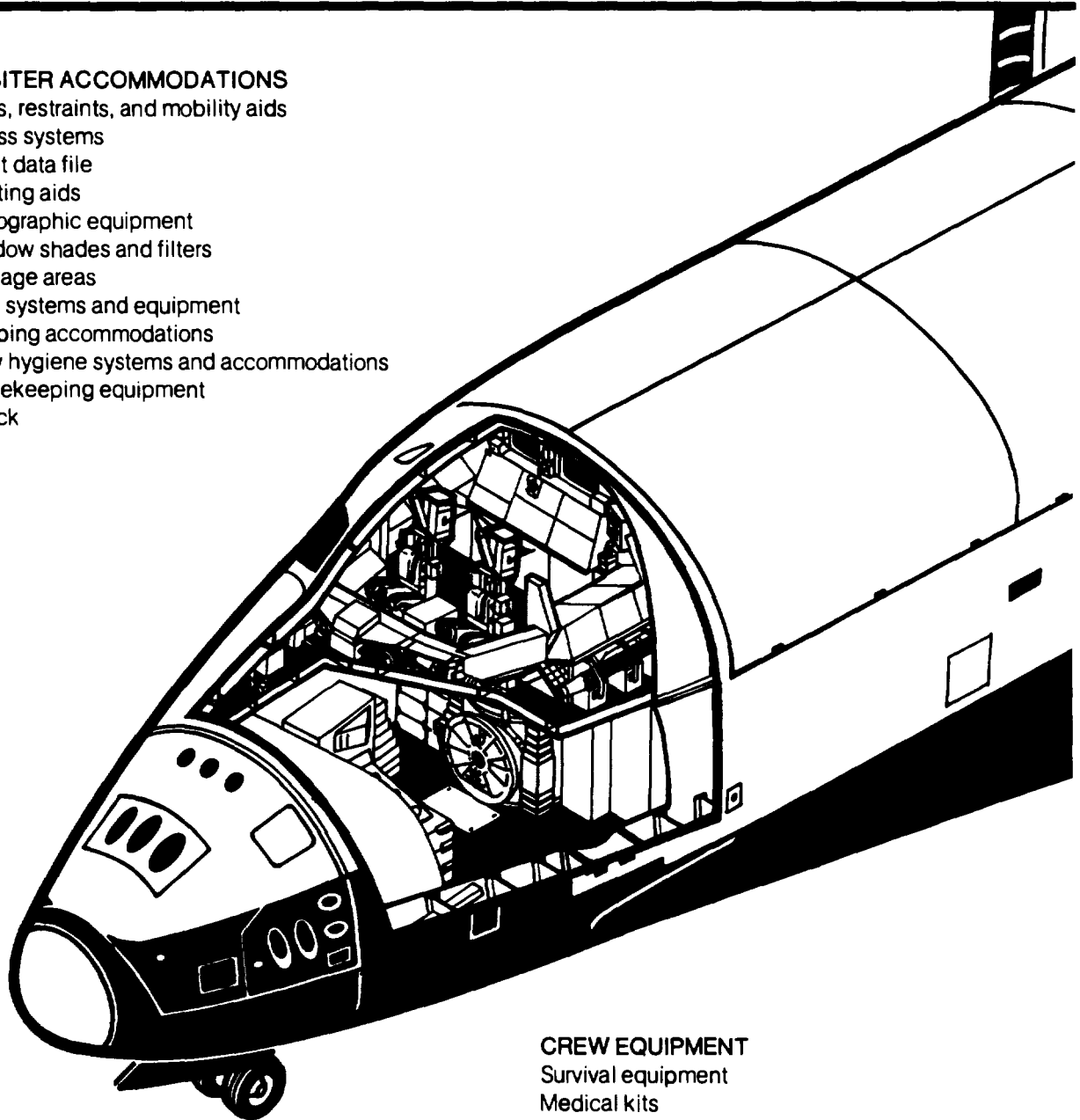

CREW EQUIPMENT

Survival equipment
Medical kits
Radiation instrumentation
Operational bioinstrumentation
Crew clothing
Space suit assembly

5. ORBITER CREW ACCOMMODATIONS AND EQUIPMENT

Orbiter, the integrated Shuttle vehicles, and the mission payloads. Seating for as many as four crewmembers can be provided. The mid deck contains passenger seating, the living area, an airlock, the galley, sleeping compartments, the toilet, and avionics equipment compartments. An aft hatch in the airlock provides access to the payload bay. The lower deck contains the environmental control equipment and is readily accessible from above through removable floor panels.

INTRODUCTION

Crew Station Configuration

The Orbiter cabin is designed as a combination working and living area (fig. 5-1). The pressurized crew compartment has a volume of 71.5 cubic meters (2525 cubic feet) and contains three levels. The flight deck contains the displays and controls used to pilot, monitor, and control the

Located outside the crew module in the payload bay are provisions for a docking module and a transfer tunnel with an adapter to allow crew and equipment transfer for docking, Spacelab, and extravehicular operations.

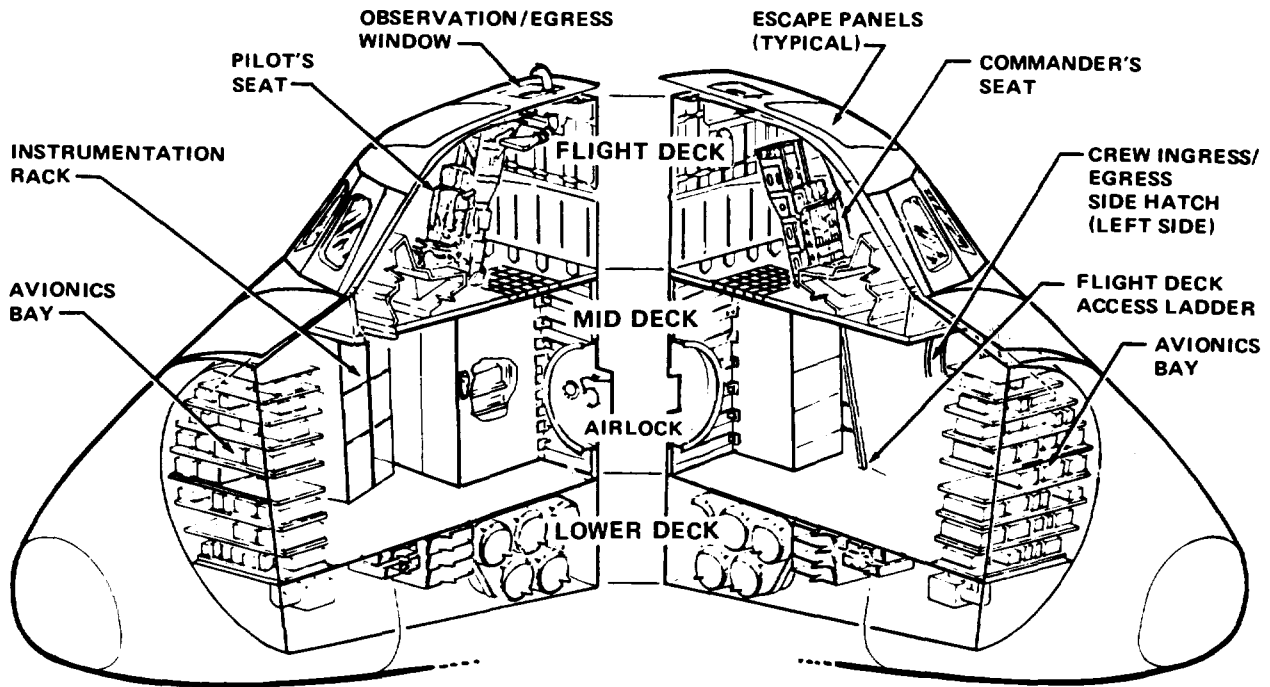

Figure 5-1.—Orbiter crew station.

Crew Schedule

The daily routine for crewmembers aboard flights of the Space Transportation System will vary according to crew assignment but each member will follow a detailed schedule each day. Time is allotted for each person for sleep, personal hygiene, work, meal preparation, and eating as well as routine Orbiter subsystem housekeeping. A 24-hour time period is normally divided into an 8-hour sleep period and a 16-hour awake period for each crewmember. Adjustments will be made to the daily schedule when specific flight activities require. One- or two-shift operations will depend on the number of crewmembers and the specific flight and operational requirements.

Sleep

Two fixed sleeping bags and two alternate locations are located in the mid deck for crewmembers (fig. 5-2). During a one-shift operation, all crewmembers sleep simultaneously; concurrent sleep periods are scheduled for two-shift operations.

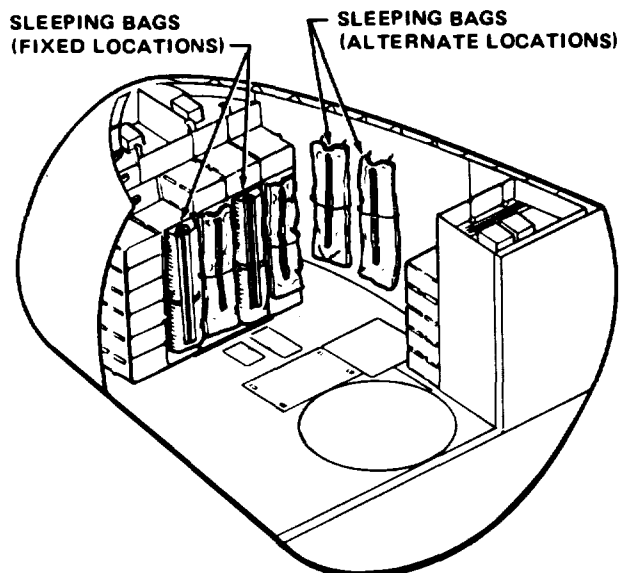

Figure 5-2.—Sleeping bag use locations.

If all crewmembers are sleeping simultaneously, at least one will wear a communication headset to ensure reception of ground calls and Orbiter caution-and-warning alarms. The headset is connected to a nearby communication outlet in the mid deck. All crewmembers wear noise-suppressing earplugs while sleeping. Forty-five minutes is allocated for each crewmember to prepare for bed and another 45 minutes is set aside when they wake to wash and get ready for the day ahead.

Meals

Three 1-hour meal periods are scheduled for all onboard the Orbiter. This hour includes actual eating time and the time required to clean up. Breakfast, lunch, and dinner are scheduled as close to routine hours as possible. Dinner will be scheduled at least 2 to 3 hours before crewmembers begin preparations for sleep. A galley and dining/work area will be located in the mid deck. The galley area includes a food preparation center, food and equipment storage, hot and cold water dispensers, food trays, an oven, a water heater, and waste storage. A 20-minute food preparation period is required 30 minutes before the meal. (See the section entitled "Food System" for additional details.)

Other Activities

In addition to time scheduled for sleep and meals, each crewmember has housekeeping tasks that require from 5 to 15 minutes of his time at given intervals throughout the day. These include cleaning the waste compartment, dumping excess water, replacing the carbon dioxide scrubbing canisters (see the section entitled "Housekeeping System"), purging the fuel cells, giving daily status reports to the ground controllers, and aligning the inertial measurement unit (the device that directs the vehicle attitude in space). A 15-minute period is also set aside at the end of each day for one of the crewmembers to put the garbage out.

ORBITER ACCOMMODATIONS

Seats, Restraints, and Mobility Aids

Seats, restraints, and mobility aids (figs. 5-3 to 5-5) are provided in the Orbiter to enable the crew to perform all tasks safely and efficiently and to provide them with proper body positioning. These devices include operational seats; foot restraint platforms/shoes; work/dining table and portable desk; in-flight restraints such as Velcro, snaps, bungees, tethers, and sleep restraints; and mobility aids and devices. Foot restraints, handholds, and mobility aids are also provided in the Spacelab.

The commander and pilot operational seats, which replace the ejection seats, provide proper body positioning so that control of the vehicle can be maintained throughout the flight. These seats provide comfortable support and proper body positioning during launch, entry, and orbital flight.

The specialist seats are similar to the commander and pilot seats and are required to provide support and restraint during launch and entry or during high-acceleration maneuvers. During flight, these seats may be removed and stowed. Restraints used in conjunction with the seats consist of two shoulder harnesses and a lapbelt.

The adjustable foot restraints in the Orbiter and the Spacelab are used for orbital operations only. An adjustable foot restraint platform in the Orbiter is provided for use at the onorbit station. The restraint platform is required for crewman optical alignment sight (COAS) operations and may be required for all out-the-window operations for small crewmembers. Suction-cup foot restraint shoes are provided for securing crewmen to various crew station locations and to the foot restraint platform.

The mid-deck work/dining table accommodates as many as four persons simultaneously for dining; it is also used as a workbench with appropriate retention devices for orbital operations. It is stowed during launch and entry and unstowed as required during orbital operations. As many as four portable work desks are supplied to provide portable work surfaces for retaining material and as an alternate means of supporting the food trays.

In-flight restraints such as Velcro, snaps, straps, and bungees are provided to assist in securing various in-flight equipment.

Mobility aids and devices are provided for all passageways within the crew module, the docking module, the airlock, and the Spacelab. These devices include handholds, footholds, handrails, and ladders and are permanently attached to the Orbiter.

Operational seats.— Adjustable seats for the commander and pilot allow movement of the seats in both the fore/aft and up/down directions for launch and orbit. The specialist seats are mounted to the flight deck and mid deck. Restraints are built into the seat system and controls are provided to lock and unlock the seat back for tilt change. The specialist seats can be removed and installed without tools by using the quick-disconnect fitting on each seat leg. These seats can be folded and stowed in the mid deck.

Foot restraint platform and shoes.— The foot restraint platform used at the aft-flight-deck onorbit stations can be preadjusted from 7.6 to 30.5 centimeters (3 to 12 inches) in height as desired by the crewman. Laced and zippered shoes are worn by the crewmen for the entire flight. Two suction cups installed on a plate attached to the shoe are used to secure the crewmen to the deck of the Orbiter and the Spacelab during orbital operations.

Mobility aids and devices.— Mobility aids and devices are located in the Orbiter for movement of the flightcrew before launch and during orbital flight. These devices consist of (1) handholds for ingress and egress to and from crew seats for launch and landing configurations, (2) handholds in the primary interdeck access opening for ingress and egress for launch and landing configurations, (3) a platform in front of the airlock for ingress and egress to and from the mid-deck seats when the Orbiter is in the launch configuration, and (4) an interdeck access ladder for egress from the flight deck to the mid deck after landing. Additional mobility aids are provided on the aft mid-deck manufacturing access panel when the airlock is removed.

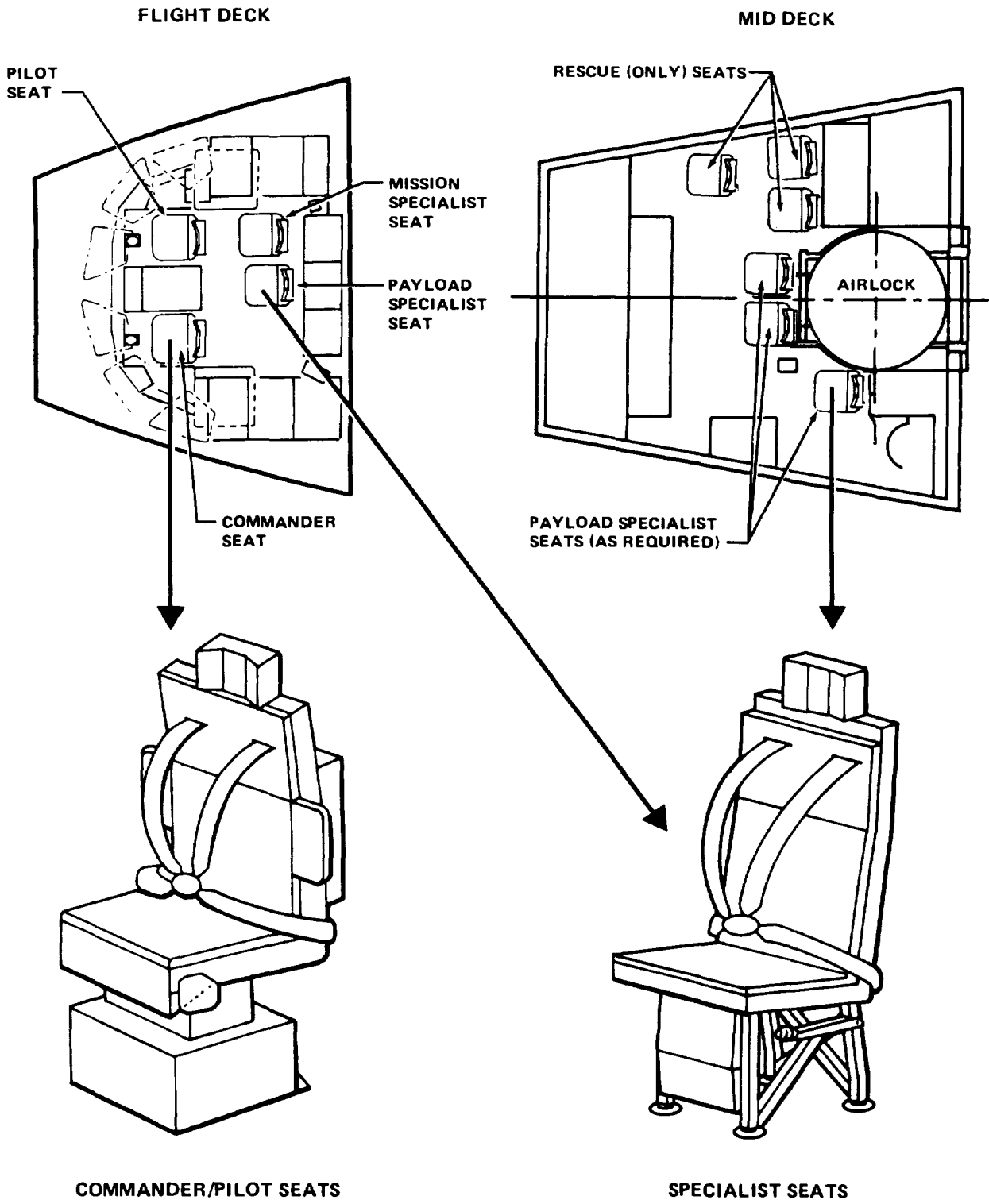
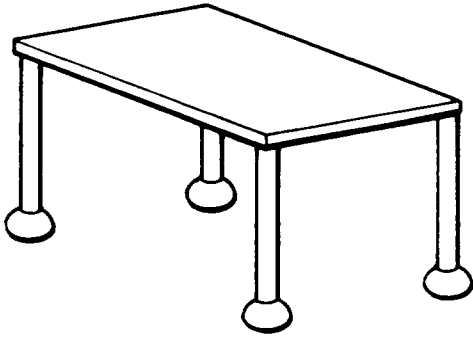
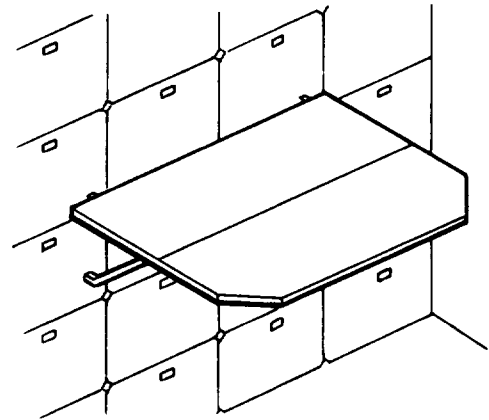

Figure 5-3.—Operational seats installed.

FOOT RESTRAINT PLATFORM



WORK/DINING TABLE



AIRLOCK FOOT RESTRAINT

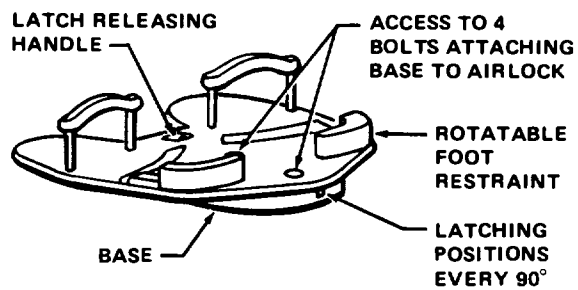

PORTABLE DESK

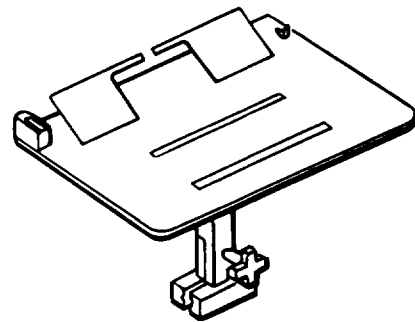

FOOT RESTRAINTS/PLATFORMS

- FOOT RESTRAINT PLATFORM FOR CREW HEIGHT ADJUSTMENT
- SUCTION-CUP SHOES FOR SECURING CREWMAN TO VARIOUS DECK LOCATIONS
- FOOT RESTRAINT PLATFORM (AIRLOCK)

TABLE AND DESK

- SUPPORTS IN-FLIGHT WORK/DINING ACTIVITIES
- CLIPS, MAGNETS AND CLAMPS PROVIDED FOR RETENTION

Figure 5-4.—Restraints (typical).

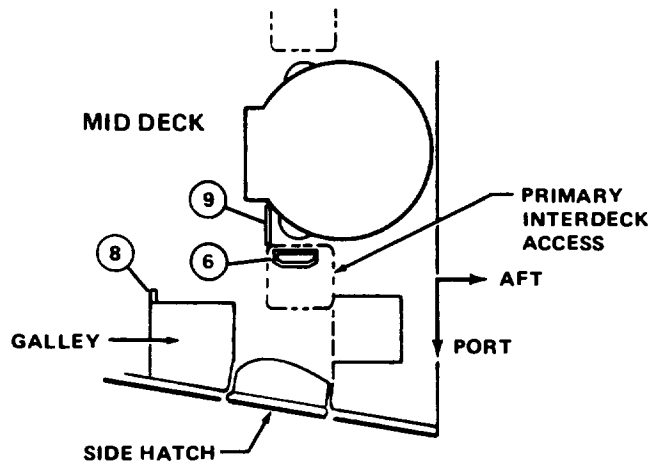
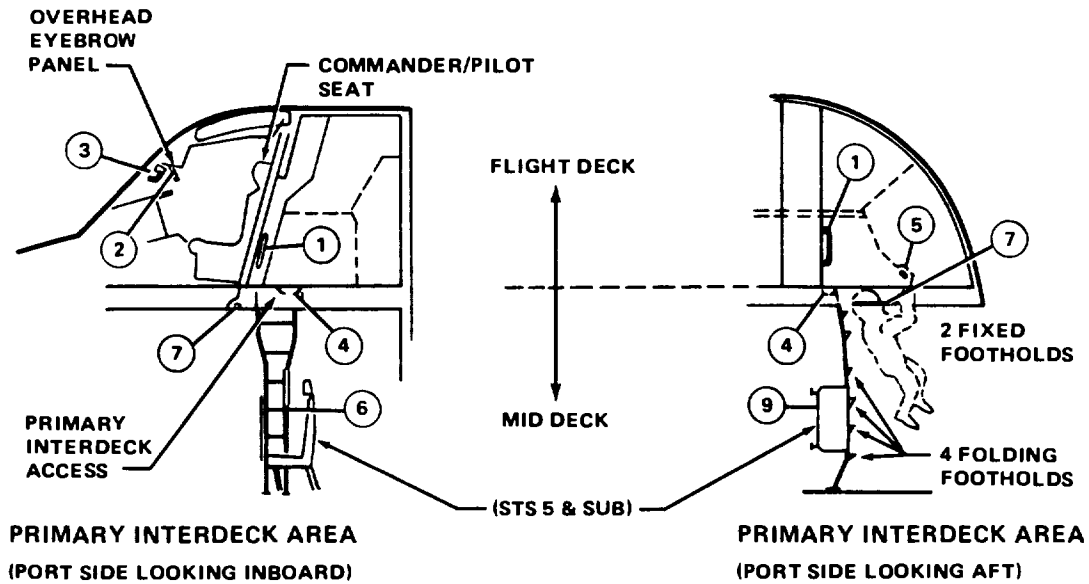

NO.	NAME	LOCATION	PRIMARY USE
1	SEAT RAIL HANDHOLD	COMMANDER'S SEAT	INTERDECK TRANSFER
2	EYEBROW HANDHOLD (FOLDING)	OVERHEAD EYEBROW PANEL	SEAT INGRESS/EGRESS
3	WINDOW POST HANDHOLD	WINDOW POSTS	SEAT INGRESS/EGRESS
4	FLIGHT-DECK FLOOR HANDHOLD	FLIGHT-DECK FLOOR	INTERDECK ACCESS
5	PRIMARY INTERDECK ACCESS HANDHOLD	ABOVE ACCESSWAY	INTERDECK ACCESS
6	INTERDECK ACCESS LADDER (4 FOLDING AND 2 FIXED FOOTHOLDS)	BELOW ACCESSWAY	INTERDECK ACCESS
7	INTERDECK ACCESS HANDRAIL	ACCESSWAY	INTERDECK ACCESS
8	GALLEY HANDHOLD	FOOD PREPARATION STATION	PAD EGRESS
9	INGRESS/EGRESS PLATFORM	FORWARD OF LADDER	PAD INGRESS/EGRESS

Figure 5-5.—Mobility aids in the crew station.

Egress Provisions

Egress provisions are those pieces of hardware that have been incorporated into the Orbiter to provide the crew with egress capabilities under emergency conditions. These provisions include the escape panel system, the side hatch egress bar, thermal aprons, the descent device, the personal egress air pack (PEAP), the lifevest, and survival equipment.

The primary mode of emergency egress is through the side hatch; the escape panel system provides the secondary egress route (fig. 5-6). The thermal aprons, descent devices, and egress bar assist the crew during egress. The lifevest and the survival equipment assist the crew after egress.

The escape panel system consists of the ejection escape panels and the left-hand overhead window (LOW) escape panel. The LOW escape panel will replace the ejection escape panels when the operational seats replace the ejection seats.

The side hatch egress bar helps stabilize the crewmember's drop to the ground during egress through the primary route.

The thermal aprons provide thermal protection from the exterior surfaces of the Orbiter during egress.

The descent devices provide a controlled descent from the escape panels on the top of the Orbiter down the side of the Orbiter to the ground. The descent device is restrained to the crewmember by means of the integrated harness on the pressure suit or the egress sling.

The personal egress air pack provides a regulated supply of air for egress and escape in a contaminated atmosphere.

The lifevest provides flotation for the crewmembers in case of bailout. The vest is not flown when the pressure suit and integrated harness are flown.

The survival equipment consists of the ejection seat kit and the Orbiter survival kit. The seat kit provides the equipment needed for survival for the commander and pilot individually after ejection. The Orbiter survival kit provides survival equipment for up to seven crewmembers for 48 hours after landing at a remote site. The Orbiter survival kit will be flown when the ejection seats are replaced by the operational seats or when more than two crewmembers fly before the replacement of the ejection seats.

Escape panel system.— The escape panel system is normally activated by the crew from inside the vehicle with the console jettison T-handle located in the center console. In the event the crew is partly or completely disabled, ground rescue forces can activate the system from outside the vehicle with the T-handle located behind an access door above the leading edge of the right wing. This access door is clearly marked with a rescue arrow and instructions. To prevent inadvertent activation of the system, the console T-handle has a safing pin that is removed for launch and entry. The LOW escape panel has a pyrotechnic system that jettisons the panel for exit from the Orbiter.

Side hatch egress bar.— The side hatch egress bar is permanently attached to the side hatch and serves as a handhold for jumping off the side hatch. It reduces the drop to the ground from the inboard side of the hatch from 3 meters (10.5 feet) to approximately 1 meter (3.5 feet).

For egress out the side hatch, the crewmember deploys the egress bar, a 3.18-centimeter (1.25-inch) diameter bar with a knurled handle at the end. The bar swings out for use.

Thermal aprons.— Thermal aprons are protective covers used by the crewmember to drape over external surfaces of the vehicle that he may contact during egress. The temperature of the outer hatch structure is 425 to 450 K (150° to 175° C or 300° to 350° F) and the thermal protection tiles on top of the Orbiter are approximately 365 K (90° C or 200° F). The apron has attach points to anchor the apron to predetermined attach points at the egress exit.

PRIMARY EGRESS ROUTE

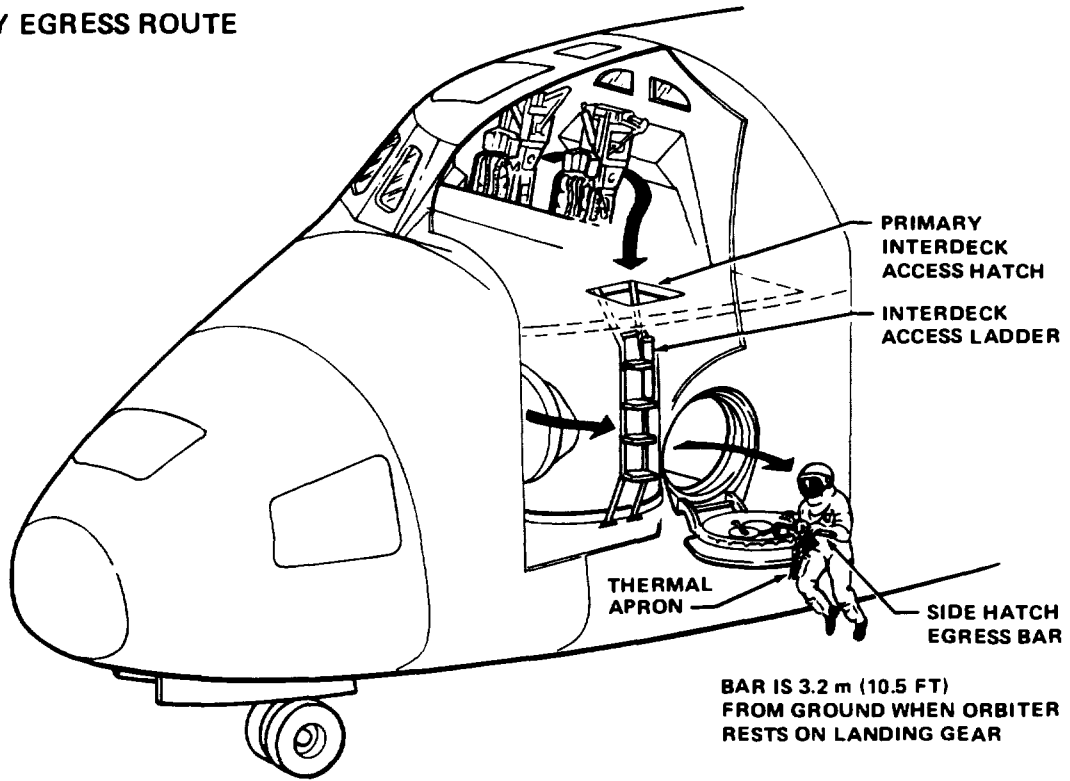

SECONDARY EGRESS ROUTE

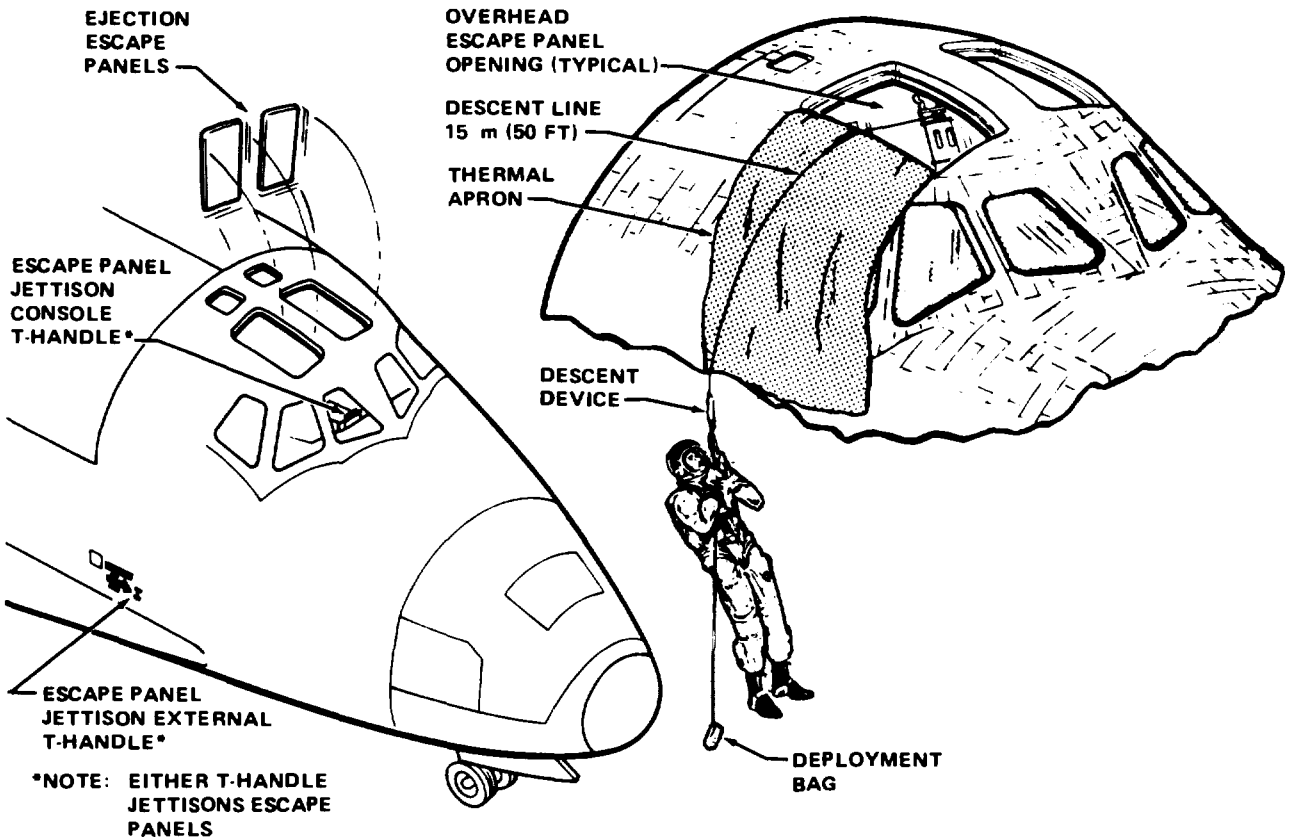

Figure 5-6.—Postlanding egress routes with ejection seats.

Descent device.— The descent device permits emergency egress through the ejection seat panels or the right-hand overhead escape panel at a controlled rate of descent. Each descent device consists of a descent line, a tether, a descent control assembly, and a deployment bag.

The descent line is a 0.97-centimeter (0.38-inch) diameter nylon line with a preformed loop on one end to anchor it. The tether is attached to the lower end of the descent control by a swivel fitting and connects to the crewmember's integrated harness or egress sling by a snap fitting. The descent control assembly allows the crewmember to lower himself to the ground at a controlled rate of descent. The deployment bag houses the stowed descent line and prevents line entanglement before deployment.

The commander and pilot each have a descent device in a stowage bag located on the inboard side of the commander's seat rail support structure. The two descent devices are anchored to the seat rail support structure by clevises. Other crewmembers will have their own descent devices.

When the ejection seats are flown, the descent device is used for emergency egress through the ejection escape panels; when the operational seats are flown, it will be used for emergency egress through the LOW escape panel.

Personal egress air pack.— The personal egress air pack provides air for egress (normal and emergency) for the commander and pilot only and is worn when the atmosphere inside or outside the Orbiter is contaminated or not known to be safe.

Lifevest.— The lifevest provides 24 hours of flotation for a maximum-sized crewmember. It is designed so that the performance of emergency tasks will not be degraded when the vest is worn. The lifevests will be stowed on the seats within easy reach of the crewmembers.

Survival equipment.— The Orbiter survival kit provides land and sea survival capability for seven crewmembers for 48 hours. The kit is packaged in a single container sized to be deployed through the side hatch or the LOW escape panel by a single crewmember. The kit contains an eight-man liferaft with a carbon dioxide inflation assembly, a mooring lanyard assembly, two oral inflation tubes, a bellows pump, a bailing bucket, and a sea anchor; signaling equipment consisting of a personal distress signal kit, two smoke/illumination flares, a Sun mirror, two radio beacons with spare batteries, and two sea dye markers; and other equipment consisting of a two-part individual survival kit, a survival blanket, a survival knife assembly, and a desalter bag and chemical packets.

Flight Data File

The Flight Data File (FDF) is a flight reference data file that is readily available to crewmen within the Orbiter. It consists of the onboard complement of documentation and related crew aids (fig. 5-7) and includes (1) FDF documentation, such as procedural checklists (normal, backup, and emergency procedures), malfunction procedures, crew activity plans, schematics, photographs, cue cards, star charts, Earth maps, and crew notebooks; (2) FDF stowage containers; and (3) FDF ancillary equipment, such as tethers, clips, tape, and erasers.

The Flight Data File is similar for all flights in quantity and stowage locations except that the seat back module is not flown with the ejection seats. Mid-deck modules redesignated as flight-deck modules will be flown for onorbit flight-deck FDF stowage on those flights. The baseline stowage volume is sufficient to contain all FDF items for all Orbiter configurations except the pallet-mounted payload. In this case, a larger Flight Data File, and consequently additional locker space, is required because all payload operations are performed in the Orbiter.

FDF items are used throughout the flight—from prelaunch use of the Ascent Checklist through crew egress use of the Entry Checklist.

Packaging and stowage of Flight Data Files are accomplished on an individual flight basis. FDF items will be stowed in five types of stowage containers: lockers, the flight-deck module, the commander's and pilot's seat-back FDF assemblies, the mid-deck FDF assembly, and the map bag. The portable containers are stowed in a mid-deck modular locker for launch and entry.

If the flight carries a Spacelab module, all Spacelab books are stowed for launch in a portable container on the mid deck and transferred in flight to a location in the Spacelab. The FDF stowage is flexible and easily accessible.

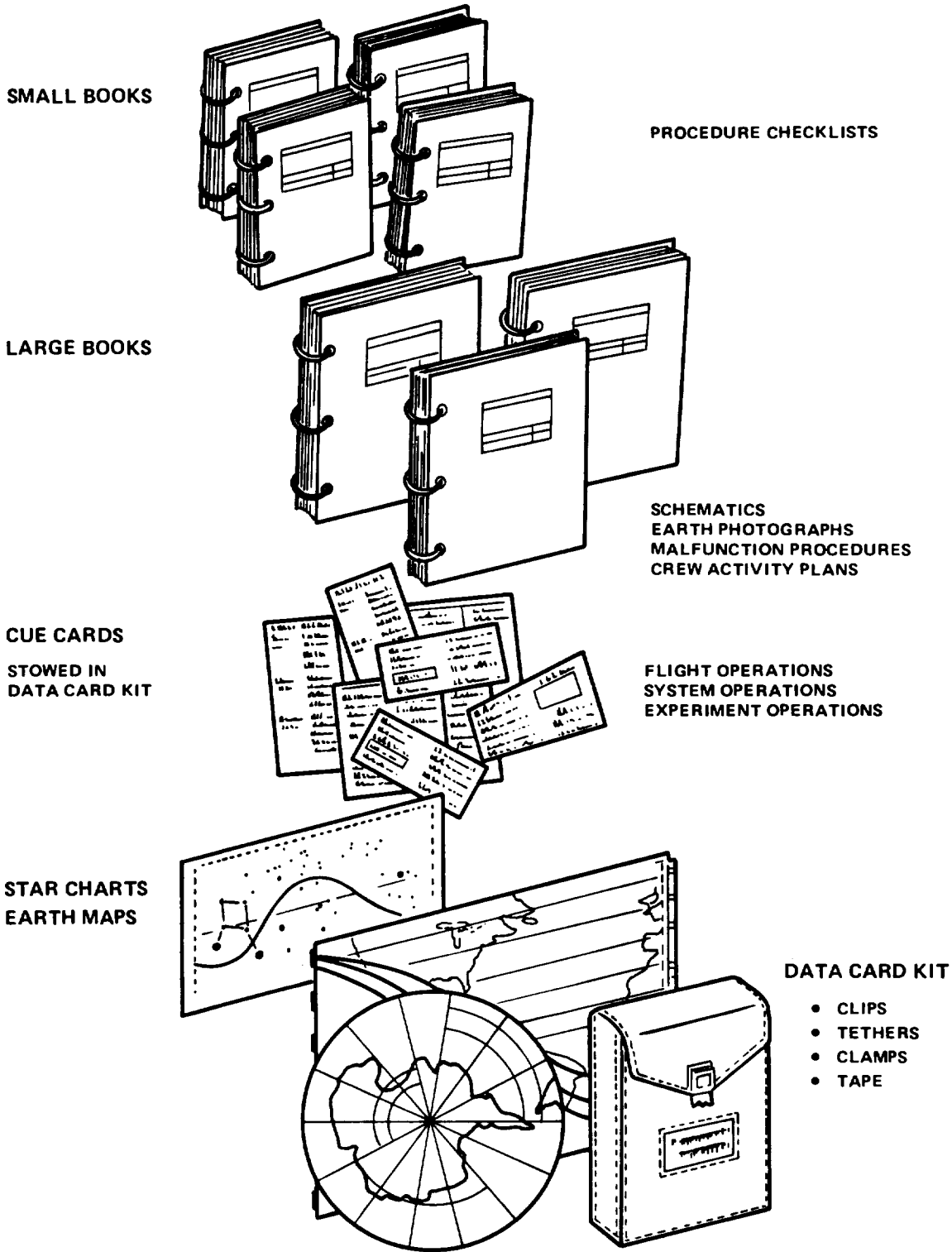

Figure 5-7.—Flight Data File items.

Sighting Aids

Sighting aids include all items used to aid crew and passenger visibility within and outside the crew module. Sighting aids include the crewman optical alignment sight (COAS) (fig. 5-8), the payload bay door COAS (PLBD COAS), binoculars (fig. 5-9), and adjustable mirrors.

The COAS is used onorbit to provide (1) range and range rate during rendezvous and docking, (2) a fixed line-of-sight attitude reference for verification of inertial measurement unit (IMU) and star tracker performance, (3) the capability for backup IMU alignment, and (4) a backup attitude check before any major burn.

The PLBD COAS provides the capability to check PLBD thermal/vibrational misalignment onorbit. The COAS and PLBD COAS must be activated for use and deactivated after use.

The binoculars can be used to view objects in the payload bay and remote to the Orbiter.

The adjustable mirrors provide rear and side visibility to each crewmember for assessing Orbiter and External Tank separation. The mirrors are also used to check controls and to display status and man/seat interfaces.

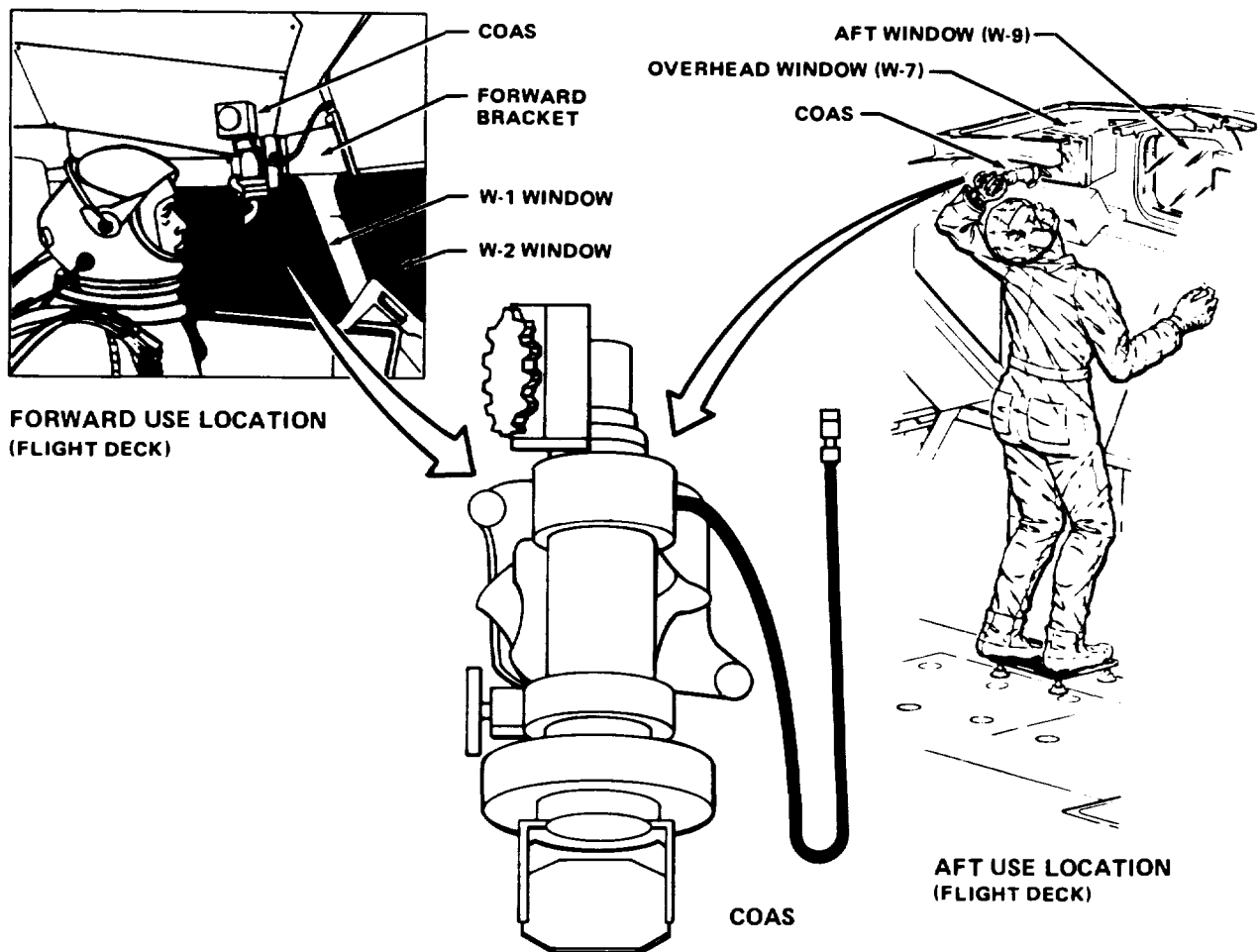

Figure 5-8.—Crewman optical alignment sight components and use locations.

Crewman optical alinement sight.— The COAS is used in the right-hand overhead window to provide range and range rate for rendezvous/docking, for IMU backup alinement, and for Z-axis sighting. The COAS is used in the left-hand forward window for stationkeeping/tracking and miscellaneous Orbiter alinement tasks and as a backup location for IMU alinement.

The COAS is a collimator device similar to an aircraft gunsight. The COAS weighs approximately 1 kilogram (2.5 pounds), is 24 centimeters (9.5 inches) long, and requires Orbiter 115 ± 5 volt alternating-current power. The COAS consists of a lamp with an intensity control, a reticle, a barrel-shaped housing, a mount, a combiner assembly, and a power cable. The reticle consists of a 10° circle, vertical and horizontal crosshairs with 1° marks, and an elevation scale on the right side of -10° to 31.5°.

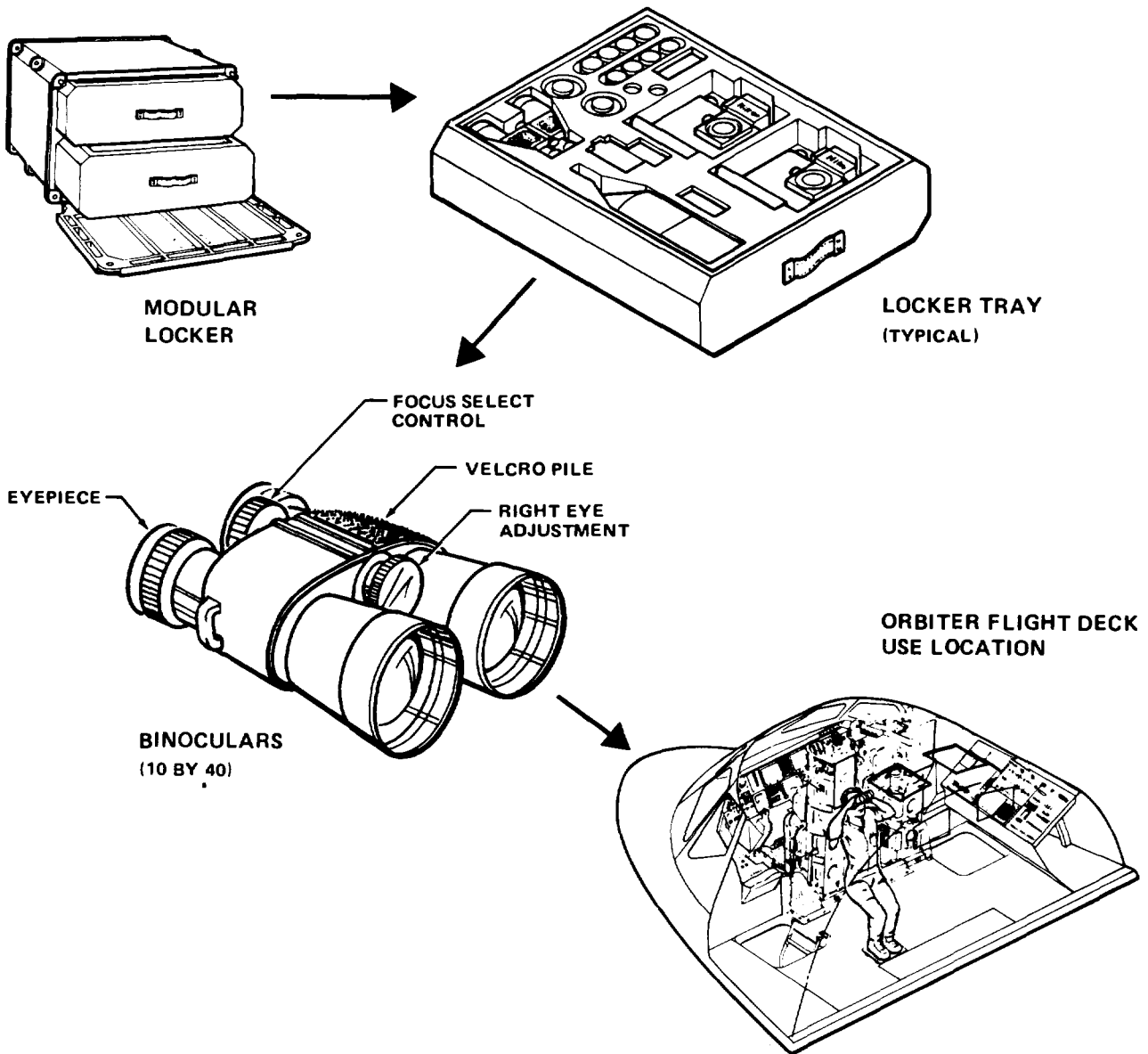

Figure 5-9.—Binoculars.

PLBD COAS.— The PLBD COAS is used in the aft window during onorbit operations to determine the amount of door deflection and to determine that the payload bay doors have closed.

Binoculars.— The 10 by 40 binoculars are a space-modified version of the commercial Leitz Trinovid binoculars. This unit is noted especially for its small size, high magnification, wide field of view, and rugged sealed construction.

Adjustable mirrors.— The adjustable mirrors are approximately 8 by 13 centimeters (3 by 5 inches) and weigh less than 0.5 kilogram (1 pound). The mirrors (one each for the commander and pilot) are mounted on the forward flight deck vertical handholds. The mirror is mounted on a ball and can be adjusted by rotating it to the desired position.

Photographic Equipment

Three camera systems—16, 35, and 70 millimeter—will be used by the Orbiter crews to document activities inside and outside the Orbiter. All three camera systems are used to document onorbit operations; the 16-millimeter camera is also used during the launch and landing phases of the flight.

All 16-millimeter camera equipment is the same configuration as that used during the Apollo, Skylab, and Apollo-Soyuz Test Project missions and the Shuttle Approach and Landing Test. The only exception is the camera mount. The 16-millimeter camera is a motion-picture-type camera with independent shutter speeds and frame rates. The camera can be operated in one of three modes: pulse, cine, or time exposure. In the pulse mode, the camera operates at a continuous frame rate of 2, 6, or 12 frames per second. In the cine mode, the camera operates at 24 frames per second. In the time-exposure mode, the first switch actuation opens the shutter and the second actuation closes it. The camera uses 43-meter (140-foot) film magazines and has 5-, 10-, and 18-millimeter lenses.

The 35-millimeter camera system is the same type as used in previous manned space flights with the exception of a new flash unit. The camera is a motorized battery-operated Nikon camera with reflex viewing, through-the-lens coupled light metering, and automatic film advancement. The camera has three automatic (electrically controlled) modes of operation—single exposure, continuous, and time—plus the standard manual mode. The 35-millimeter camera uses an f/1.4 lens.

The 70-millimeter camera system is composed of the same equipment as used during the Apollo-Soyuz Test Project. It is a modified battery-powered motor-driven single-reflex Hasselblad camera and is provided with 80- and 250-millimeter lenses and film magazines. Each magazine contains approximately 80 exposures. The 70-millimeter camera has only one mode of operation, automatic; however, there are five automatic-type camera functions from which to select. The camera has a fixed viewfinder that provides through-the-lens viewing.

Window Shades and Filters

The Orbiter windows are designed to provide external visibility for entry, landing, and orbital operations. Vision requirements for atmospheric flight require that the flightcrew be provided with forward, left, and right viewing areas. Orbital missions require visibility for rendezvous, docking, and payload handling. Potentially, these large areas of transparency will expose the crew to Sun glare; therefore, window shades and filters are provided to preclude or minimize exposure when desirable during orbital operations. The window shade and filter use locations are identified in figure 5-10.

All shades and filters are for onorbit use. Shades are provided for all windows, while filters are supplied for the aft station and overhead windows only. The overhead window shades are installed preflight for the launch and are also used during reentry. The aft window filters are installed preflight for launch and are stowed for entry. The window shades and filters are stowed on the mid deck in the galley area.

The forward-station window shades (W-1 through W-6) are fabricated from Kevlar epoxy glass fabric with silver and Inconel-coated Teflon tape on the outside surface and paint on the inside surface. When the shade is installed next to the inner window pane, a silicone rubber seal around the periphery deforms to prevent light leakage. The shade is held in place by the shade installation guide, the hinge plate, and the Velcro keeper.

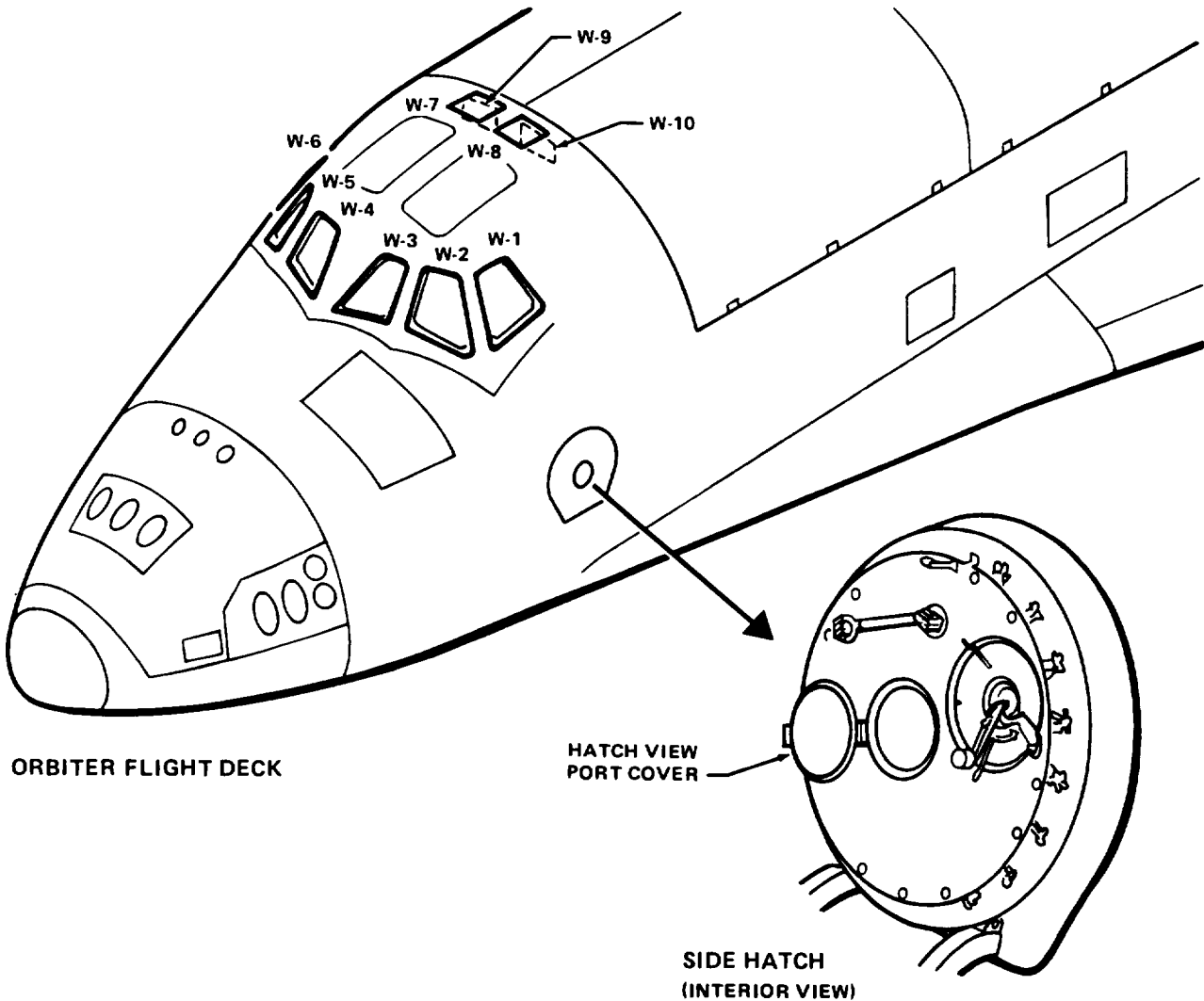

Figure 5-10.—Window shade and filter locations.

The overhead window shades (W-7 and W-8) are the same as the forward shades except the rubber seal is deleted and the shade is sealed and held in place by a separate seal around the window opening, a hinge plate and secondary frame, and a Velcro retainer. The overhead window filters are fabricated from Lexan and are used interchangeably with the shades.

The aft window shades (W-9 and W-10) are the same as the overhead window shades except that a 1.6-centimeter (0.63-inch) wide strip of Nomex Velcro hook has been added around the perimeter of the shade. The shade is attached to the window by pressing the Velcro strip to the pile strip around the window opening. The aft window filters are the same as the overhead window filters except for the addition of the Velcro hook strip. The filters and shades are used interchangeably.

The side-hatch window cover is permanently attached to the window frame and is hinged to allow opening and closing.

Crew Equipment Stowage

Crew equipment onboard the Orbiter will be stowed in lockers with insertable trays. The trays can be adapted to accommodate a wide variety of soft goods, loose equipment, and food. The lockers are interchangeable and attach to the Orbiter with screw fittings. The lockers can be removed or installed in flight by crewmen. There are two sizes of trays: a half-size tray (two of which fit inside a locker) and a full-size tray. Approximately 4.2 cubic meters (150 cubic feet) of stowage space is available, almost 95 percent of which is on the mid deck.

The lockers will be made of either epoxy- or polyimide-coated Kevlar honeycomb material joined at the corners with aluminum channels. Inside dimensions are approximately 25 by 43 by 50 centimeters (10 by 17 by 20 inches). The honeycomb material is approximately 0.64 centimeter (0.25 inch) thick and was chosen for its strength and light weight. The lockers contain about 0.06 cubic meter (2 cubic feet) of space and can hold up to 27 kilograms (60 pounds).

Dividers will be used in the trays to provide a friction fit for zero-g retention. This will reduce the necessity for straps, bags, Velcro snaps, and

other cumbersome attach devices previously used. Soft containers will be used in Orbiter spaces too small for the fixed lockers.

The trays will be packed with gear in such a way that no item covers another or, if it does, the gear is of the same type. This method of packing will reduce the confusion usually associated with finding and maintaining a record of loose equipment.

Stowage areas in the Orbiter crew compartment are located in the forward flight deck, the aft flight deck, the mid deck, the equipment bay, and the airlock module.

In the forward flight deck, the Flight Data File is located to the right of the pilot's seat. A fire extinguisher is located forward of the file below the pilot's window. Special provisions for the orbital flight test phase are attached to both the commander's and the pilot's seats. These provisions include the emergency survival kit, parachutes, the portable oxygen system, and (behind the commander's seat) the emergency egress kit.

In the aft flight deck, stowage lockers are located below the rear payload control panels in the center of the deck. Container modules can be mounted to the right and left of the payload control station. Since these side containers are interchangeable, they may not be carried on every mission, depending on any payload-unique installed electronic gear.

In the mid deck, container modules can be inserted in the forward avionics bay. Provisions for 33 containers are available in this area. In addition, there is an area to the right side of the airlock module where nine containers can be attached.

Lithium hydroxide (LiOH) canisters will be stowed below the mid deck in the equipment bay.

The airlock module will be used to stow equipment directly related to extravehicular activity, such as the extravehicular mobility unit (space suit/backpack).

Food System

The Orbiter is equipped with food, food storage, and food preparation and dining facilities to provide each crewman with three meals per day plus snacks and an additional 96 hours of contingency food. The food supply and food preparation facilities are designed to accommodate flight variations in the number of crewmen and flight durations ranging from two crewmen for 1 day to seven crewmen for 30 days.

The galley, which is located in the cabin working area (fig. 5-11), is modular and can be removed for special missions. In addition to cold and hot water dispensers, it will be equipped with a pantry, an oven, food serving trays, a personal hygiene station, a water heater, and auxiliary equipment storage areas. The oven will be a forced-air convection heater with a maximum temperature of 355 K (82° C or 180° F). There are no provisions for food freezers or refrigerators.

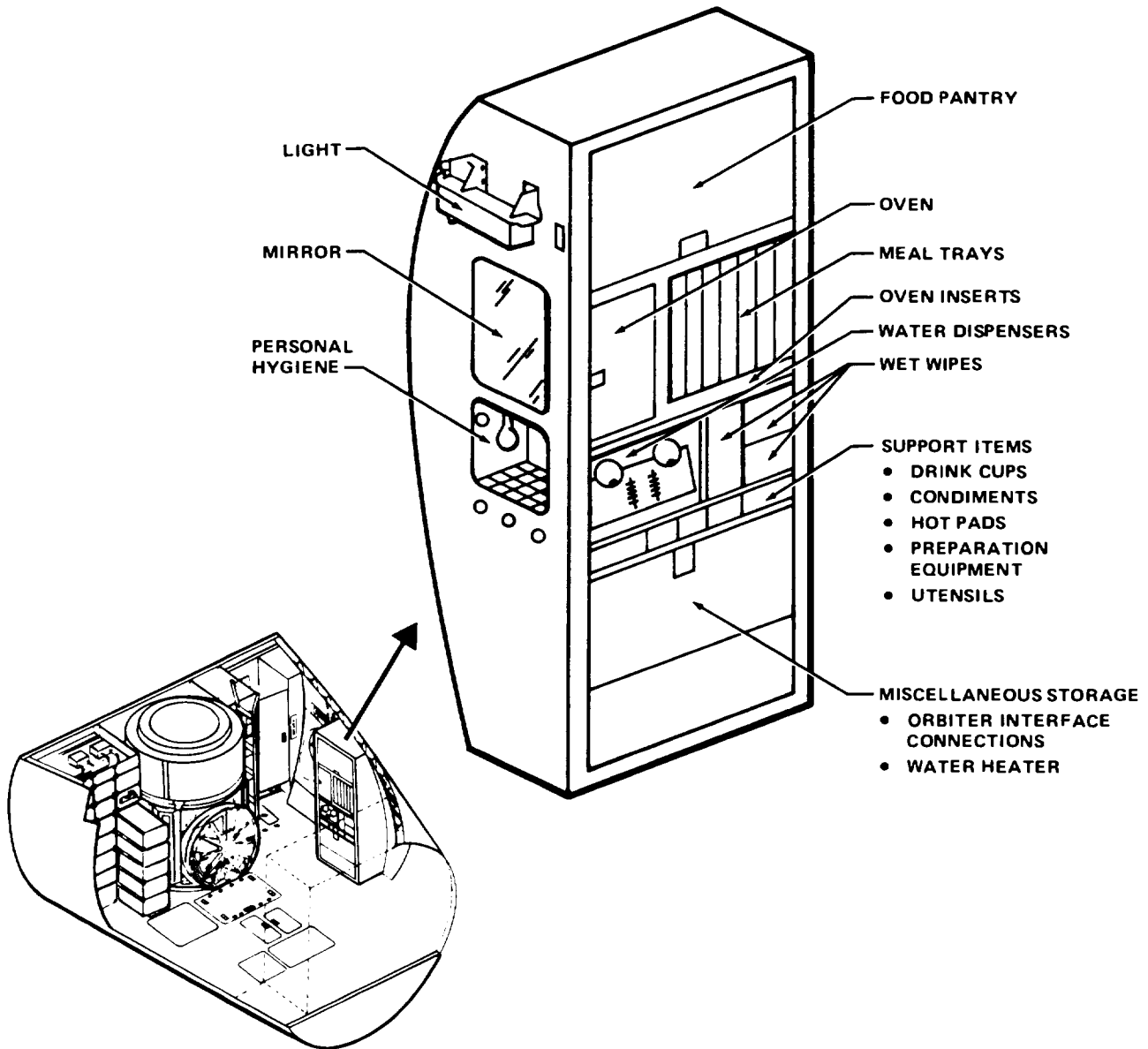

Figure 5-11.—Galley configuration (concept).

The food consists of individually packaged serving portions of dehydrated, thermostabilized, irradiated, intermediate moisture, natural form, and beverage foods. The food system relies heavily on dehydrated food, since water is a byproduct of the fuel cell system onboard the Orbiter. Off-the-shelf thermostabilized cans, flexible pouches, and semirigid plastic containers will be used for food packaging.

The menu will be a standard 6-day menu instead of the personal-preference type used in previous programs. The menu will consist of three meals each day plus additional snacks and beverages (table 5-I). The daily menu will be designed to provide an average energy intake of 3000 calories for each crewmember. The food system also includes a pantry of foods for snacks and beverages between meals and for individual menu changes (table 5-II).

Food preparation activities will be performed by one crewman 30 to 60 minutes before mealtime. The crewman will remove the selected meal from the storage locker, reconstitute those items that are rehydratable, place the foods to be heated into the galley oven, and assemble other food items on the food trays.

Meal preparation for a crew of seven can be accomplished by one crewmember in about a 20-minute period. Utensils and trays are the only items that require cleaning after a meal. Cleaning will be done with sanitized "wet wipes" that contain a quaternary ammonium compound. As on the Skylab flights, the crewmembers will use regular silverware.

TABLE 5-I.— SPACE SHUTTLE TYPICAL MENU*

DAY 1	DAY 2	DAY 3	DAY 4
Peaches (T) Beef patty (R) Scrambled eggs (R) Bran flakes (R) Cocoa (B) Orange drink (B)	Applesauce (T) Beef jerky (NF) Granola (R) Breakfast roll (I) (NF) Chocolate instant breakfast (B) Orange-grapefruit drink (B)	Dried peaches (IM) Sausage (R) Scrambled eggs (R) Cornflakes (R) Cocoa (B) Orange-pineapple drink (B)	Dried apricots (IM) Breakfast roll (I) (NF) Granola w/blueberries (R) Vanilla instant breakfast (B) Grapefruit drink (B)
Frankfurters (T) Turkey tetrazzini (R) Bread (2) (I) (NF) Bananas (FD) Almond crunch bar (NF) Apple drink (2) (B)	Comed beef (T) (I) Asparagus (R) Bread (2) (I) (NF) Pears (T) Peanuts (NF) Lemonade (2) (B)	Ham (T) (I) Cheese spread (T) Bread (2) (I) (NF) Green beans and broccoli (R) Crushed pineapple (T) Shortbread cookies (NF) Cashews (NF) Tea w/lemon and sugar (2) (B)	Ground beef w/ pickle sauce (T) Noodles and chicken (R) Stewed tomatoes (T) Pears (FD) Almonds (NF) Strawberry drink (B)
Shrimp cocktail (R) Beef steak (T) (I) Rice pilaf (R) Broccoli au gratin (R) Fruit cocktail (T) Butterscotch pudding (T) Grape drink (B)	Beef w/barbeque sauce (T) Cauliflower w/cheese (R) Green beans w/mushrooms (R) Lemon pudding (T) Pecan cookies (NF) Cocoa (B)	Cream of mushroom soup (R) Smoked turkey (T) (I) Mixed Italian vegetables (R) Vanilla pudding (T) (R) Strawberries (R) Tropical punch (B)	Tuna (T) Macaroni and cheese (R) Peas w/butter sauce (R) Peach ambrosia (R) Chocolate pudding (T) (R) Lemonade (B)

*Abbreviations in parentheses indicate type of food: T = thermostabilized, I = irradiated, IM = intermediate moisture, FD = freeze dried, R = rehydratable, NF = natural form, and B = beverage.

TABLE 5-II.—SPACE SHUTTLE FOOD AND BEVERAGE LIST

Foods^a		
Applesauce (T)	Chicken and noodles (R)	Peaches, dried (IM)
Apricots, dried (IM)	Chicken and rice (R)	Peaches, (T)
Asparagus (R)	Chili mac w/beef (R)	Peanut butter
Bananas (FD)	Cookies, pecan (NF)	Pears (FD)
Beef almondine (R)	Cookies, shortbread (NF)	Pears (T)
Beef, corned (I) (T)	Crackers, graham (NF)	Peas w/butter sauce (R)
Beef and gravy (T)	Eggs, scrambled (R)	Pineapple, crushed (T)
Beef, ground w/pickle sauce (T)	Food bar, almond crunch (NF)	Pudding, butterscotch (T)
Beef jerky (IM)	Food bar, chocolate chip (NF)	Pudding, chocolate (R) (T)
Beef patty (R)	Food bar, granola (NF)	Pudding, lemon (T)
Beef, slices w/barbeque sauce (T)	Food bar, granola/raisin (NF)	Pudding, vanilla (R) (T)
Beef steak (I) (T)	Food bar, peanut butter/granola (NF)	Rice pilaf (R)
Beef stroganoff w/noodles (R)	Frankfurters (Vienna sausage) (T)	Salmon (T)
Bread, seedless rye (I) (NF)	Fruitcake	Sausage patty (R)
Broccoli au gratin (R)	Fruit cocktail (T)	Shrimp creole (R)
Breakfast roll (I) (NF)	Green beans, french w/mushrooms (R)	Shrimp cocktail (R)
Candy, Life Savers, assorted flavors (NF)	Green beans and broccoli (R)	Soup, cream of mushroom (R)
Cauliflower w/cheese (R)	Ham (I) (T)	Spaghetti w/meatless sauce (R)
Cereal, bran flakes (R)	Jam/Jelly (T)	Strawberries (R)
Cereal, cornflakes (R)	Macaroni and cheese (R)	Tomatoes, stewed (T)
Cereal, granola (R)	Meatballs w/barbeque sauce (T)	Tuna (T)
Cereal, granola w/blueberries (R)	Nuts, almonds (NF)	Turkey and gravy (T)
Cereal, granola w/raisins (R)	Nuts, cashews (NF)	Turkey, smoked/sliced (I) (T)
Cheddar cheese spread (T)	Nuts, peanuts (NF)	Turkey tetrazzini (R)
Chicken a la king (T)	Peach ambrosia (R)	Vegetables, mixed Italian (R)

Beverages	Condiments
Apple drink	Barbeque sauce
Cocoa	Catsup
Coffee, black	Mustard
Coffee w/cream	Pepper
Coffee w/cream and sugar	Salt
Coffee w/sugar	Hot pepper sauce
Grape drink	Mayonnaise
Grapefruit drink	
Instant breakfast, chocolate	
Instant breakfast, strawberry	

^aAbbreviations in parentheses indicate type of food: T = thermostabilized, I = irradiated, IM = intermediate moisture, FD = freeze dried, R = rehydratable, and NF = natural form.

Sleeping Accommodations

Two basic systems for sleeping are available on the Orbiter: sleeping bags, available on the first flights, and rigid sleep stations, available on later flights. After the rigid sleep stations are available, the Orbiter can fly with either configuration.

The sleeping bags are the same as the Apollo sleep restraints. For early flights, they will be constructed of Beta material perforated for thermal comfort and will be modified to include attach fittings for Shuttle installation. On later flights, the perforated Beta material will be replaced by perforated Nomex for better temperature control. Light masks and earplugs are provided with all sleeping bags.

Four rigid sleep stations (fig. 5-12) are provided: three horizontal stacked units and one vertical unit. Each station is provided with a sleep pallet, a sleep restraint, personal stowage, a light, ventilation inlet and outlet, and overhead light shields. The backs of the sleep restraints face toward the deck in the middle and top stations (stations 2 and 3); in the bottom sleep station (station 1), the back of the sleep restraint faces toward the overhead. This arrangement is intended to provide a 66-centimeter (26-inch) clearance between the bottom sleeping pallet and the Orbiter floor for underfloor stowage access.

Waste Collection System

The waste collection system is an integrated multifunctional system used to collect, process, and store solid and liquid wastes. The system is used the same as a standard facility and performs the following general functions: (1) collecting, storing, and drying fecal wastes, associated toilet paper, and emesis-filled bags; (2) processing wash water from the personal hygiene station; (3) processing urine; (4) transferring the collected fluids to the waste storage tanks in the waste management system; and (5) venting the air and vapors from the wet trash container and stowage compartment.

The waste collection system accommodates both male and female crewmembers and consists of the commode assembly, urinal assembly valving, instrumentation, interconnecting plumbing, mounting framework, and restraints. The waste collection system is located on the mid deck of the Orbiter in a 74-centimeter (29-inch) wide compartment immediately aft of the side hatch.

Personal Hygiene System

The personal hygiene system provides for the hygienic needs of the individual crewmembers with the following equipment: a personal hygiene station, personal hygiene kits, towels and washcloths, and a tissue dispenser.

When the galley is not flown, the personal hygiene station is located on the left side of the mid deck and provides ambient and chilled water through a flexible line to a water dispenser. No drain is provided. When the galley is flown, the personal hygiene station is located on the left side of the mid deck and provides ambient and hot water plus a drain.

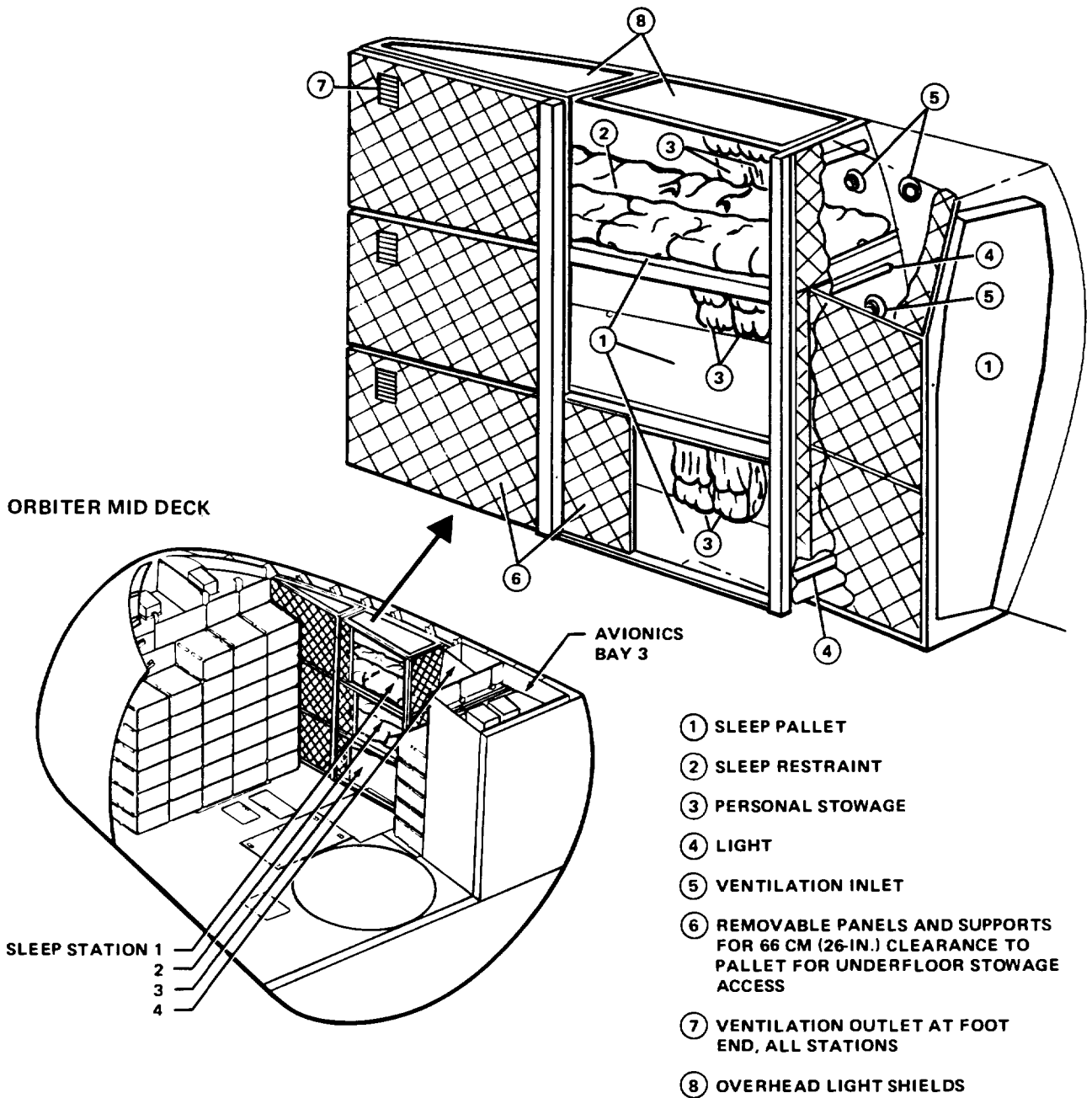

Figure 5-12.—Rigid sleep station provisions.

Personal hygiene station.— The galley with its built-in personal hygiene station will not be available on early flights. In the interim, the personal hygiene needs of the crew will be met by the water dispenser. The personal hygiene station consists basically of the hygiene water valve and water gun, which is a part of the water dispenser. The hygiene water valve is a manually operated squeeze valve that provides ambient water at 291 to 308 K (18° to 35° C or 65° to 95° F). A 22.9- by 30.5-centimeter (9- by 12-inch) Mylar mirror is provided that mounts on the waste collection system door by means of Velcro for use onorbit. The mirror is stowed for launch and entry in a modular stowage locker.

The personal hygiene station for later flights is part of the galley (fig. 5-13). In addition to ambient water from the Orbiter water system, the galley water heater provides hot water. The personal hygiene station includes a hand washing enclosure, a mirror, a light, a soap dispenser, and controls for water dispensing, draining, and temperature adjustment.

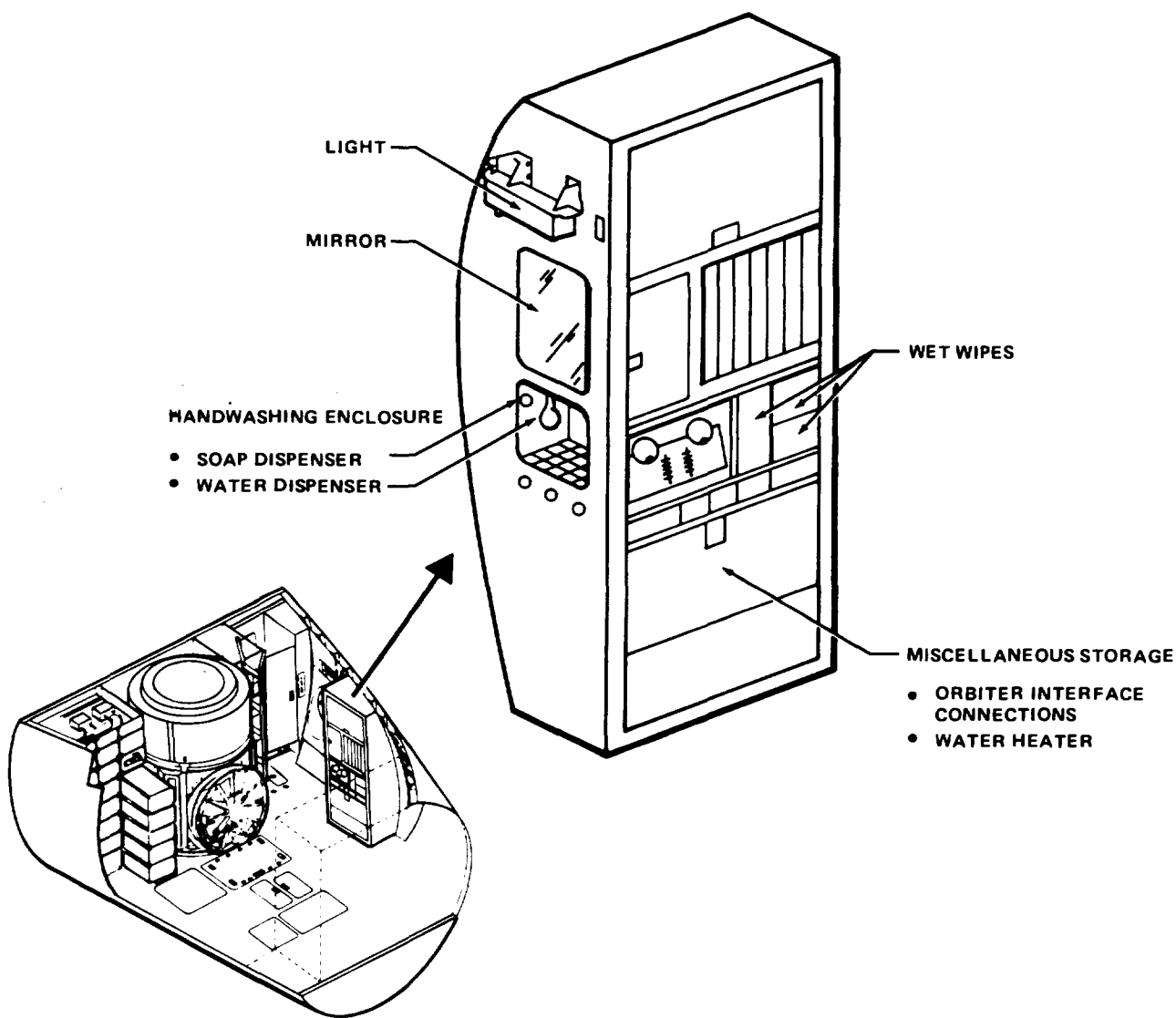

Figure 5-13.—Personal hygiene equipment onorbit locations (with galley).

Fluid waste from the personal hygiene station is discharged into the waste collection system. Fluid wastes are low sudsing and relatively free of particulates to be compatible with the operation of the waste collection system fan separators. A mixing valve at the personal hygiene station adjusts water temperature, a water valve activates the water ejection, and an airflow valve connects the personal hygiene station to the waste collection system.

Personal hygiene kits.— A personal hygiene kit (fig. 5-14) is furnished for each crewman to provide for dental hygiene, hair care, nail care, shaving, etc. A typical personal hygiene kit contains a toothbrush, toothpaste, dental floss, and an antichap lipstick; a comb and brush; nail clippers; shaving cream, a safety razor and blades or a mechanical (windup) shaver, and a styptic pencil; skin emollient; soap; and stick deodorant.

Pockets, loops, and Velcro are provided in the personal hygiene kit containers to maintain articles in an orderly manner and to permit efficient removal, use, and replacement of components in flight. The maximum weight of the kit will be 2.3 kilograms (5 pounds).

Towels and washcloths.— A quantity of towels sufficient to support one crewman for 7 days is packaged together to form a towel assembly. Each crewmember is provided with seven cotton washcloths and three cotton towels. The washcloths are 30.5 by 30.5 centimeters (12 by 12 inches) and the towels are 46.6 by 68.8 centimeters (16 by 27 inches).

Tissue dispenser.— The tissues are paper and are absorbent, multi-ply, and low-linting. The quantities carried are the same as for the towels.

ORIGINAL PAGE IS
OF POOR QUALITY

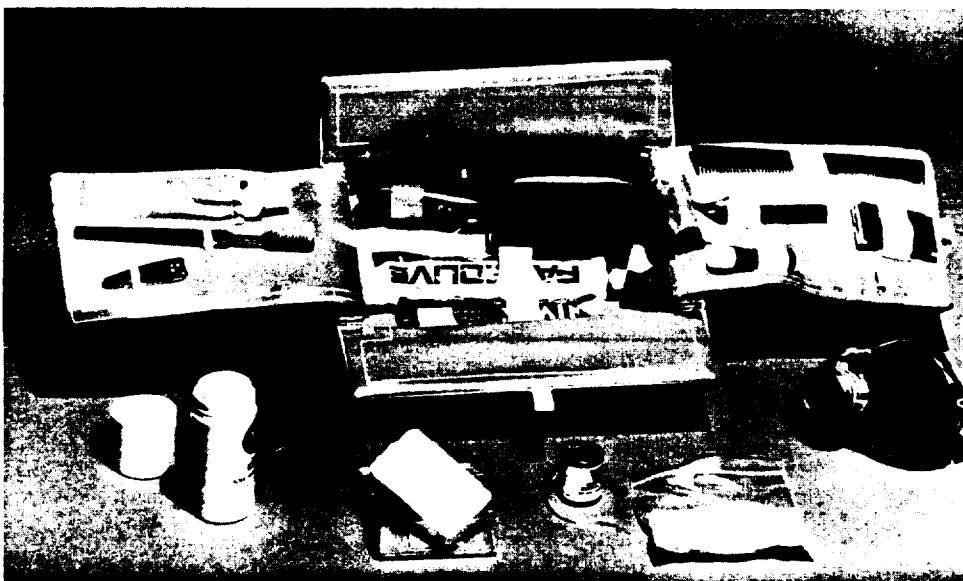

Figure 5-14.—Personal hygiene kit (NASA S-80-27348).

Housekeeping System

The housekeeping system is used for cleaning the Orbiter crew station in orbit. The major components of the system are cleaning equipment, carbon dioxide absorbers, trash containers, and replacement parts.

The three trash accumulators, for both wet and dry trash, interface with the Orbiter in their use locations and are stowed for launch and entry. The wet trash containers are connected to the waste management system through a vent hose. Cleaning materials are stowed in lockers. The carbon dioxide absorbers (lithium hydroxide canisters) are stowed in a mid-deck floor stowage compartment and are periodically placed in the environmental control system downstream from the fans. Used absorbers are stowed in the original container. The vacuum cleaner is stowed in a modular locker and is powered by the Orbiter electrical power system.

Cleaning equipment.— The cleaning operations performed in the Orbiter include cleaning the waste collection system urinal and seat, the dining area and equipment, floors and walls (as required), the personal hygiene station, and the air filters.

The materials and equipment available for cleaning operations are biocidal cleanser, disposable gloves, general-purpose wipes, and a vacuum cleaner.

The biocidal cleanser is a liquid biocidal detergent formulation in a container approximately 5 centimeters (2 inches) in diameter and 15 centimeters (6 inches) long, with a built-in bladder, dispensing valve, and nozzle. The cleanser is sprayed on the surface to be cleaned and wiped clean with dry general-purpose wipes. The cleanser is used for periodic cleansing of the waste collection system urinal and seat, the dining area and equipment, and the personal hygiene station. It will also be used, as required, to clean walls and floors. Disposable plastic gloves are worn while using the biocidal cleanser.

General-purpose wipes are dry wipes used to spread the biocidal cleanser and to dry the cleaned surface; they are also used for general-purpose cleaning.

The vacuum cleaner is provided for general housekeeping and for cleaning the Orbiter cabin air filter and the Spacelab environmental control system filters.

Carbon dioxide absorbers.— The carbon dioxide absorbers are lithium hydroxide canisters that are placed in the Environmental Control and Life Support System (ECLSS) to filter carbon dioxide from the recirculated air. The absorbers are stowed in a mid-deck floor compartment. They are removed from stowage and inserted into the environmental control system according to the number of people onboard. The absorber changeout schedule is shown in table 5-III.

TABLE 5-III.— CARBON DIOXIDE ADD RATE/REPLACEMENT TIME

Number in crew	Carbon dioxide add rate, kg/hr (lb/hr)	Absorber cartridge replacement time, hr	Cartridge alternating changeout time, hr
4	0.160 (0.352)	24	12
7	.279 (.616)	11	5.5
10	.399 (.880)	6.4	3.2

The system will operate with two active absorber cartridges that are changed on a rotating basis. The nominal carbon dioxide partial pressure in the Orbiter cabin is 666 N/m² (5.0 mmHg) within a range of 0 to 1013 N/m² (0 to 7.6 mmHg). The lithium hydroxide bed of the absorber cartridge is sized to maintain the carbon dioxide partial pressure within this range when changed out as scheduled in table 5-III.

Trash containers.— The trash management operations include routine stowage and daily collection of wet and dry trash such as expended wipes, tissues, and food containers. Wet trash includes all items that could offgas. The equipment available for trash management includes trash bags, trash bag liners, wet trash containers, and the stowable wet trash vent hose.

Three trash bags are located in the crew compartment. Each bag contains a disposable trash bag liner. Two bags will be designated for dry trash and one for wet trash. At a scheduled time each day, the dry trash bag liner will be removed from its trash bag. The trash bag liner will be closed with a strip of Velcro and stowed in an empty locker.

For long-duration flights when more than 0.23 cubic meter (8 cubic feet) of wet trash is expected, the wet trash bag liners will be removed at a scheduled time each day and placed in a wet trash container. The container is then closed with a zipper and the unit is stowed. If expansion due to wet trash offgassing is evident, the container is connected to a vent in the waste management system for overboard venting.

The wet trash container is made of airtight fabric and is closed with a seal-type slide fastener. The container has a volume of approximately 0.02 cubic meter (0.7 cubic foot) and has an air inlet valve on one end and a quick disconnect on the other end. The container is attached to the waste management vent system at a point beneath the commode, enabling air to flow through the wet trash container and then overboard. Attachment is made through a 104-centimeter (41-inch) long vent hose filter. When the container is full, it is removed and stowed in a modular locker.

A 0.2-cubic-meter (8-cubic-foot) wet trash stowage compartment is available under the mid-deck floor. Each day, the wet trash bag liners will be removed from the trash bags and stowed in the wet trash stowage compartment, which is vented overboard. If the compartment becomes full, the wet trash bag liners will be stowed in wet trash containers.

Orbiter Airlock

The airlock in the Shuttle Orbiter accommodates astronaut extravehicular operations without the necessity for cabin decompression or for decompression of an attached pressurized manned payload in the Orbiter payload bay.

The airlock (fig. 5-15) is a modular cylindrical structure 160 centimeters (63 inches) inside diameter by 210 centimeters (83 inches) long with two D-shaped pressure-sealing hatches and a complement of airlock support systems. Access to the airlock from the crew compartment and from the airlock to the payload bay is provided by the two hatches located on opposite sides of the airlock.

The airlock is removable and can be installed in one of three different Orbiter locations (fig. 5-16), depending on the payload carried. The baseline location is inside the crew compartment, allowing maximum use of the payload bay volume. The airlock may also be rotated 180° and positioned in the payload bay, still attached to the aft cabin bulkhead. For a habitable payload mission such as Spacelab, the airlock may be positioned on top of a pressurized tunnel adapter, which connects the cabin with the pressurized payload.

The airlock provides stowage during flight for the extravehicular mobility unit. During extravehicular activity (EVA), the airlock supplies oxygen, cooling water, communications, and power to the crewmen.

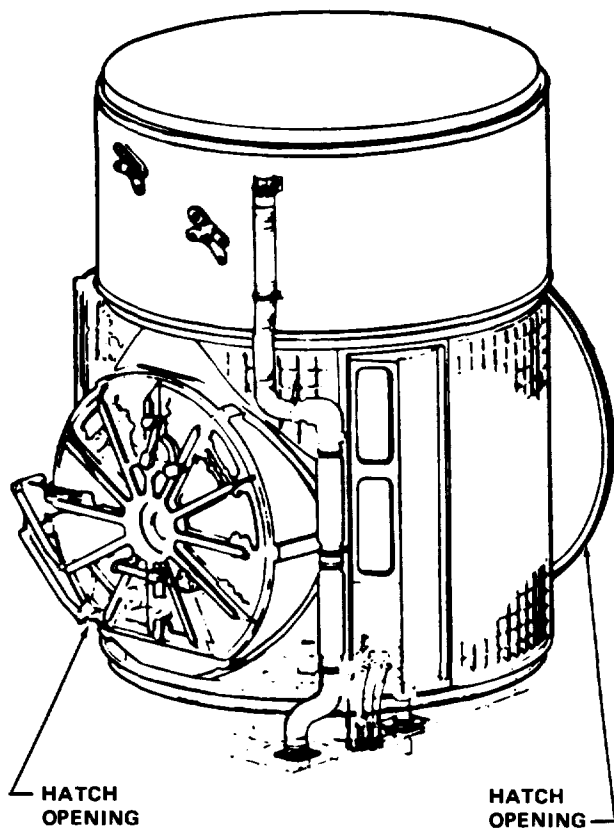

Figure 5-15.—Airlock.

Airlock structure.— The primary structure of the airlock is composed of machined aluminum sections welded together to form a cylinder with hatch mounting flanges. The upper cylindrical section and the bulkheads are made of nonvented aluminum honeycomb. Two semicylindrical aluminum sections are welded to the airlock primary structure to house the ECLSS and avionics support equipment. Each semicylindrical section has three feedthrough plates for plumbing and cable routings from the Orbiter to support the airlock subsystems.

Airlock hatches.— The airlock hatches permit the EVA crewmember to transfer from the Orbiter crew compartment to the payload bay. Both airlock hatches open toward the primary pressure source, the Orbiter cabin. Each hatch opening has a clear passageway 101.6 centimeters (40 inches) in diameter, with one flat side that reduces the minimum dimension of the hatch opening to 91.4 centimeters (36 inches).

Airlock depressurization/repressurization system.— The airlock depressurization system is designed to discharge an airlock volume of 3.8 cubic meters (133 cubic feet), assuming two suited crewmembers are in the airlock, at a rate of 620 pascals/sec in 6 minutes. Following the EVA and hatch closing, the airlock volume is repressurized by using the equalization valve on the airlock/cabin hatch. Each airlock has two pressure equalization valves that are operable from both sides of the hatch.

Four repressurization modes are available to the crewmember following an EVA. One mode is considered normal, two are classified as emergency modes because of time constraints on either the space suit or the crewmember, and the fourth is for rescue operations.

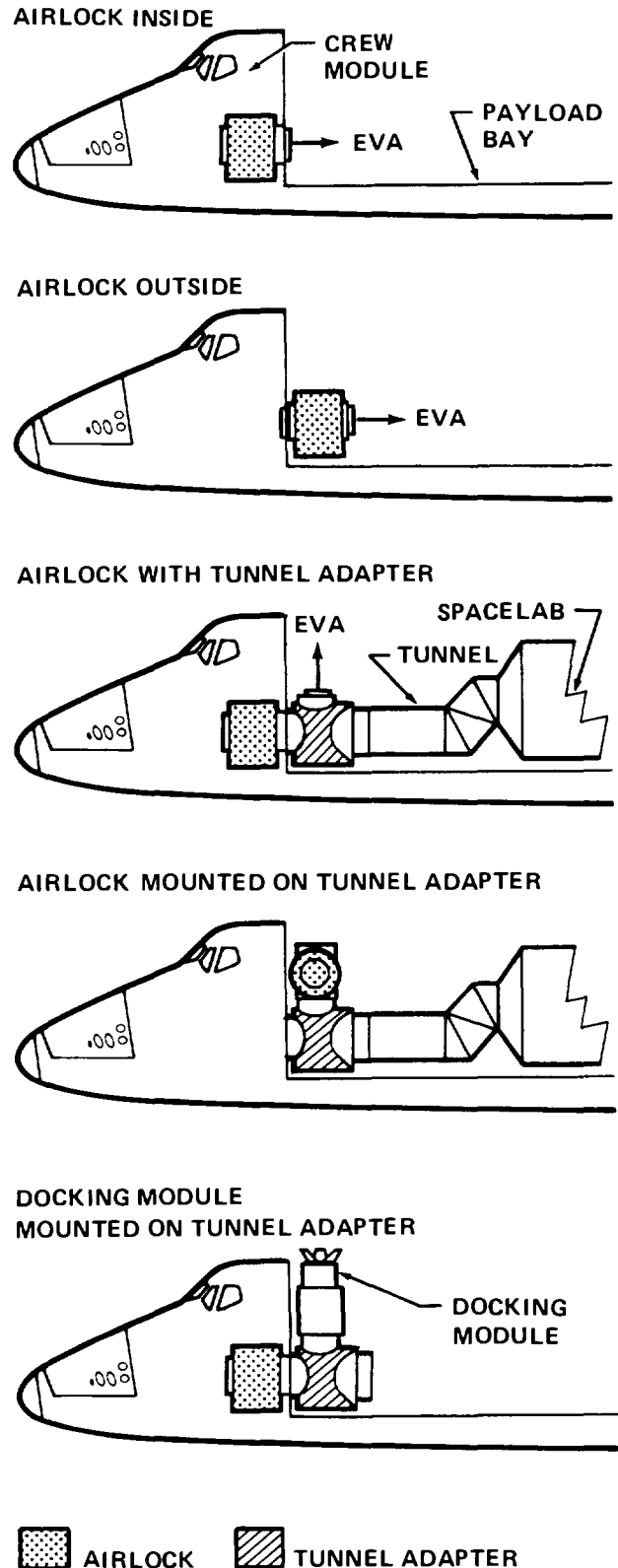

Figure 5-16.—Airlock/tunnel adapter configurations.

CREW EQUIPMENT

Shuttle Orbiter Medical System

The Shuttle Orbiter Medical System (SOMS) has provisions for medical care for minor illnesses and injuries as well as for stabilizing severely injured or ill personnel until return to Earth. Additionally, diagnostic equipment and information will allow diagnosis and treatment of injuries and illnesses through consultation with flight surgeons in the Mission Control Center.

Medical kits are available for use on orbit for all flights. For short-duration flights, the SOMS-A will be provided. The SOMS-A contains two kits, the Emergency Medical Kit (EMK) and the Medications and Bandage Kit (MBK). The Emergency Medical Kit includes both diagnostic and therapeutic items. The Medications and Bandage Kit contains bandages and medications such as pills, topicals, and ointments. For longer duration flights and for flights where personnel are of questionable medical status, the SOMS-B will be provided. The SOMS-B has a greater medical capability than the SOMS-A and will be used for most flights.

Each SOMS kit is designed to allow flexibility for selecting appropriate medical items in kit and module forms to accommodate specific flight requirements. The SOMS is packaged to allow quick access to emergency medication and instruments. The SOMS is stowed in a modular locker on the mid deck. For orbital use, the kit may be attached with Velcro to any locker door. The SOMS-A and -B are described as follows.

SOMS-A.— The SOMS-A (fig. 5-17) weighs 4 kilograms (9 pounds) and has a volume of 0.02 cubic meter (0.6 cubic foot). The SOMS-A is contained in two packages, each of which contains three packs. The Emergency Medical Kit contains Pack A, Injectables; Pack B, Emergency Items; and Pack C, Diagnostic/Therapeutic Items. The Medications and Bandage Kit contains Pack D, Oral Medications; Pack E, Bandage Items; and Pack F, Medications, Noninjectables.

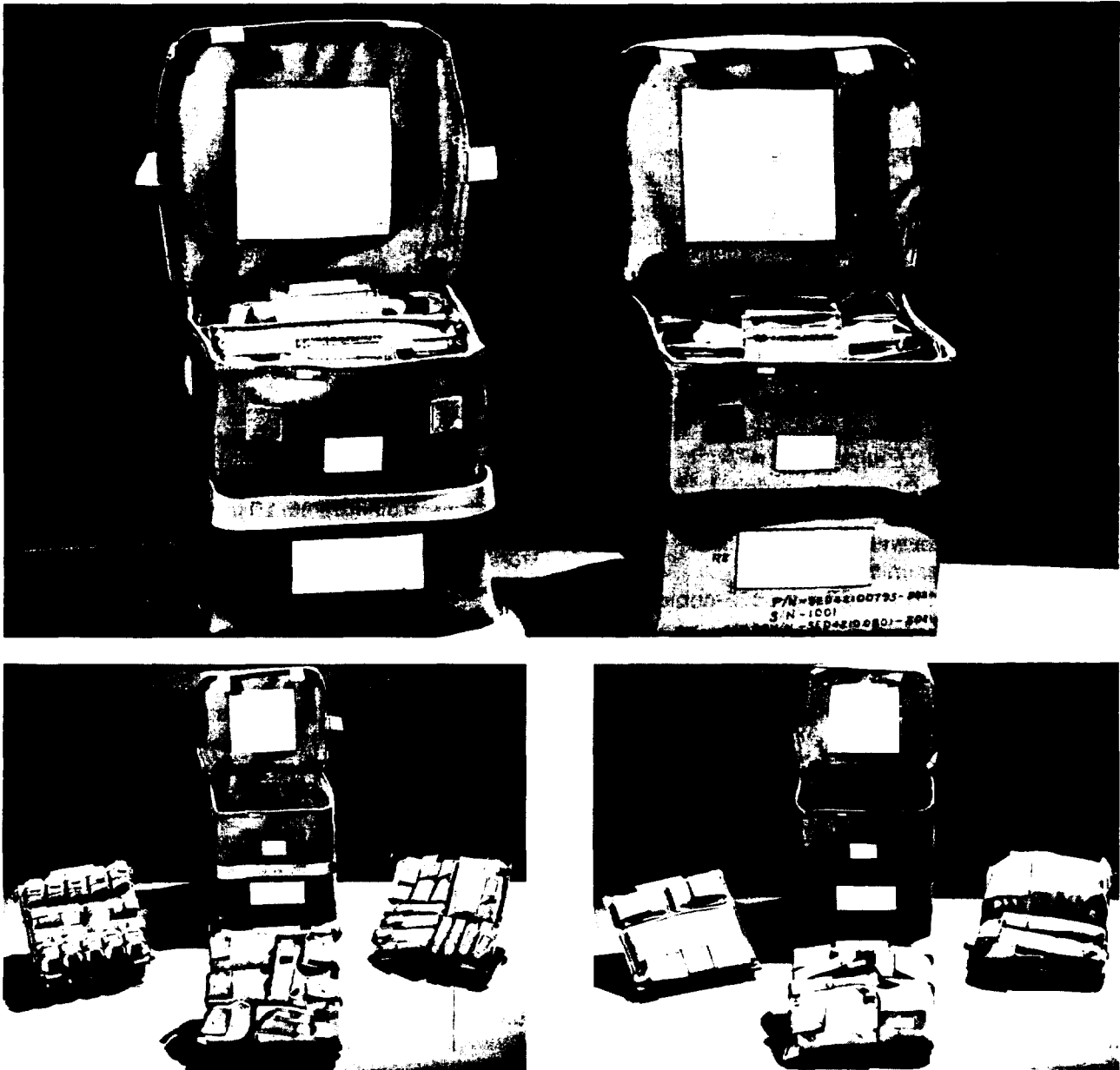

Figure 5-17.—Shuttle Orbiter Medical System A (top, NASA S-80-37855; lower left, S-80-37864; and lower right, S-80-37865).

ORIGINAL PAGE IS
OF POOR QUALITY

The contents of the Emergency Medical Kit are as follows.

Pack A, Injectables

Aramine, 10 milligrams, 1-cubic-centimeter units, 3
Atropine, 0.4 mg/cc, 2-cubic-centimeter units, 3
Epinephrine, 1:1000, 1-cubic-centimeter units, 3
Pronestyl, 500 mg/cc, 2-cubic-centimeter units, 2
Decadron, 20 mg/cc, 1-cubic-centimeter units, 3
Demerol, 25 mg/cc, 2-cubic-centimeter units, 2
Compazine, 5 mg/cc, 2-cubic-centimeter units, 3
Valium, 5 mg/cc, 2-cubic-centimeter units, 2
Phenergan, 25 milligrams (intravenously), 3
Morphine sulfate, 10 milligrams, 2
Xylocaine 2 percent with epinephrine, 1:100 000, 2-cubic-centimeter units, 1
Xylocaine 2 percent without epinephrine, 2-cubic-centimeter units, 1
Lidocaine hydrochloride, 20 mg/cc, 2-cubic-centimeter units, 3
Benadryl, 50 mg/cc, 1-cubic-centimeter units, 1
Vistaril, 50 mg/cc, 2-cubic-centimeter units, 1
Lidocaine, 20 mg/cc, 2-cubic-centimeter units, 1

Pack B, Emergency Items

100 cubic centimeters normal saline, 1
Intravenous (IV) tubing without drip chamber, 1
21-gage butterfly IV needle, 1
Syringe, 10 cubic centimeters, 2
Billab stix (with card), 1 package
Tweezers (fine point), 1
Forceps (small point), 1
Scalpel, no. 11 blade, 1
Suture, 4-0 Dexon, 1
Scalpel, no. 13 blade, 1
22-gage needle, 3.8 centimeters (1.5 inches), 2
Tubex injector, 1
Suture, 4-0 Ethilon, 1
Needle holder, 1
Scissors, curved, 1
Hemostat (abilene), 1

Pack C, Diagnostic/Therapeutic Items

Stethoscope, 1
Blood pressure cuff and sphygmomanometer, 1
Airway (adult size), 1
Cricothyrotomy setup, 1
Depressors, tongue, 5
Thermometers (disposable), 12
Penlight, 1
Foley catheter size 11 Fr., 30-cubic-centimeter

balloon, 1
Cobalt light filter, 1
Fluorescein strips, 15
Otoscope specula, 2
Otoscope, 1
Ophthalmoscope (head only), 1
Tourniquet, 1
Cotton balls, 12
Binocular loupe, 1
Sterile drape, 1
Sterile gloves

The contents of the Medications and Bandage Kit are as follows.

Pack D, Oral Medications

Actifed, 30 tablets
Ampicillin, 250 milligrams, 30 capsules
Dexdrine, 5 milligrams, 10 tablets
Erythromycin, 250 milligrams, 30 tablets
Donnatal, 30 tablets
Lomotil, 75 tablets
Dalmane, 15 milligrams, 12 capsules
Tetracycline, 250 milligrams, 30 capsules
Scop/Dex, 0.4/5 milligrams, 24 capsules
Aspirin, 5 grain, 30 tablets
Lozenges, Cepacol, 12 tablets
Pyridium, 200 milligrams, 20 tablets
Valium, 5 milligrams, 20 tablets
Tylenol no. 3, 20 tablets
Benadryl, 25 milligrams, 20 tablets
Phenergan/Dex, 25/5 milligrams, 24 tablets
Digoxin, 0.25 milligram, 20 tablets
Parafon Forte, 20 tablets
Nitroglycerin, 0.4 milligram, 20 tablets
Periactin, 0.4 milligram, 20 tablets
Sudafed, 30 milligrams, 30 tablets
Keflex, 250 milligrams, 30 capsules
Dulcolax, 5 milligrams, 10 tablets
Phenergan suppositories, 25 milligrams, 8
Aminophyllin suppositories, 500 milligrams, 8
Compazine suppositories, 25 milligrams, 8
Pen Vee K, 250 milligrams, 40 tablets

Pack E, Bandage Items

Band-aids, small (2.5 by 7.6 centimeters (1 by 3 inches)), 10
Steri-strips, package, 3
Tape, Dermicel, 2.5-centimeter (1-inch) wide roll, 1
Gauze, 7.6-centimeter (3-inch) roll, 1
Kling, 7.6 centimeters (3 inches), 2
Wipes, Betadine, 10
Adaptic nonadhering dressing, 3
Q-tips, 2/package, 4 packages
Eye patch, 4

Toothache kit, 1
Wipes, alcohol, 10
Mylanta, 24 tablets
5.1- by 5.1-centimeter (2- by 2-inch) sponges, 25
Benzoin wipes, 5
Finger splint, 1
Robitussin Cough Calmers, 12
Ace bandage, 1

Pack F, Medications, Noninjectables

Afrin nasal spray, 15 cubic centimeters, 2 bottles
Blistex, 2 tubes
Sulfacetamide ophthalmic ointment, 1 tube
Pontocaine eye drops, 15 cubic centimeters,
1 bottle
Mycolog, 15 milligrams, 1 tube
Kenalog cream, 15 grams, 1 tube
Anusol-HC, 28 grams, 1 tube
Halotex, 15 grams, 1 tube
Neocortef ointment, 1 tube
Betadine ointment (Povidone), 28 grams
(1 ounce), 1 tube
Neosporin ointment, 1 tube
Triangular dressing (75 by 75 by 135
centimeters) with safety pins, 1
Surgical masks, 2
Methylcellulose eye solution, 15 cubic
centimeters, 1
Kerlix dressing, 1
Cortisporin otic solution, 10 milliliters, 1 bottle

SOMS-B.— The SOMS-B weighs less than 8 kilograms (18 pounds) and has a volume of 0.03 cubic meter (1 cubic foot). SOMS-B consists of SOMS-A (the Emergency Medical Kit and the Medications and Bandage Kit) plus a defibrillator, an intravenous fluids system, and a positive-pressure oxygen regulator device. In some cases, the quantities of medications in the SOMS-A part of this system will be increased.

Add-on kits to the SOMS will be available to meet the requirements for more than four crewmembers and for flight lengths exceeding 7 days.

Radiation Instrumentation

The Shuttle radiation instrumentation consists of two pocket dosimeters (high and low), the crew passive dosimeter, the area passive dosimeter, the high-rate dosimeter, and dosimeter bags.

Each crewmember will carry a crew passive dosimeter somewhere on his person. The remainder of the dosimeters will be stowed preflight in lockers. The two high-rate dosimeters will remain in separate lockers throughout the flight and will be removed postflight by the ground crew. The remainder of the dosimeters will be removed from stowage onorbit and deployed to their assigned wall-mounted locations. Prior to deorbit, the units will be restowed.

Pocket dosimeters.— The operation of both the high and low pocket dosimeters is the same; the only difference is the radiation range. The units contain a quartz fiber that is positioned to zero by electrostatic charging preflight. The unit discharges according to the amount of radiation received, and, as the unit discharges, the quartz fiber moves. The position of the fiber is a function of the amount of radiation received and is noted by visual inspection, as though looking through a telescope.

Crew passive dosimeters.— The badge-type crew passive dosimeters are squares of fine-grained photographic film sandwiched between plastic separators in a lightproof package. Radiation that strikes the silver halide causes spots on the film that can be analyzed postflight. Included in the badge dosimeters are thermoluminescent chips. When radiation strikes the chip, it causes electrons to jump to a higher orbit where they remain until the chip is heated. On return to Earth, the chips are heated in a laboratory and the emitted light caused by electrons returning to their original orbits is detected by light sensors. Also included in the package are sandwiched pieces of plastic that aid in determining radiation.

Area passive dosimeters.— The area passive dosimeters are functionally similar to the crew units but are much larger.

High-rate dosimeters.— The high-rate dosimeters are functionally the same as the pocket dosimeters but are slightly larger in size.

Dosimeter bags.— The dosimeter bags contain either one or two pocket dosimeters and a crew passive dosimeter. The flap of the bag is fitted with Velcro for closing, and the back of the bag contains Velcro for mounting on the wall. The bag and contents together form a dosimeter assembly. Each assembly is numbered (1 to 6) to correspond with Velcro patches at various locations in the Orbiter.

Operational Bioinstrumentation

The operational bioinstrumentation system (OBS) provides an amplified electrocardiograph (ECG) analog signal from any two designated crewmembers onboard the Shuttle to the Shuttle avionics where it is transmitted to the ground in real time or stored on tape for dump or postflight return. The major components of the system are a battery-operated signal conditioner, batteries, cables, and electrodes.

The operational bioinstrumentation system is used on all flights during prelaunch, launch, and entry. Onorbit use is limited to extravehicular activity (EVA) unless intravehicular activity (IVA) use is requested by the flight surgeon.

For flights in which the crewmembers wear pressure suits, the OBS is routed through the crewmembers' constant-wear garments and ejection seats and restrained to the pressure suit and seat. For shirt-sleeve flights, the OBS is routed through the crewmember's constant-wear garment and flight suit and restrained to the flight suit and seat. For all flights, the OBS interfaces with one or two of the five biomedical jacks.

Three electrodes are placed on the skin in the standard OBS configuration (one sternal, one right chest, and one lateral lead position). The electrodes detect the moving electric field generated by heart muscle depolarization and repolarization, and this electric field is amplified and conditioned by the signal conditioner.

Use of the OBS in the Shuttle mission phases is as follows.

Preflight.— Crewmembers will be instrumented preflight with the aid of technicians. After Orbiter ingress, the OBS/vehicle interfaces will be made and the ECG data will be transmitted real time through the launch umbilical. Two data channels are available; however, data from more than two crewmembers (five maximum) may be transmitted by sequential sampling. Those crewmembers that will be instrumented are as follows:

With two crewmembers: the commander and pilot
With three or four crewmembers: the mission specialist and the payload specialist
With more than five crewmembers: payload specialists only

Launch.— The ECG data (two channels) will be recorded onboard on the telemetry recorder. Sequential sampling is required to record data on more than two crewmembers. No action is required by the crewmembers during this phase.

Postorbital insertion.— The crewmembers will doff the OBS's and stow the electrodes, signal conditioners, and cables. The data recorded during launch will be dumped to the ground per ground command.

Onorbit intravehicular operations.— In case of illness, the flight surgeon may request that the OBS be donned for a period of time. In this event, the OBS will be donned and the data will be transmitted in real time or recorded and dumped in near real time.

Extravehicular activity.— The ECG data on two EVA crewmen can be transmitted in real time to the ground during flights in which an EVA transmitter is carried.

Entry preparation and entry.— Entry preparations for the OBS include unstowing the electrodes, signal conditioners, and cables; attaching the electrodes to the chest; connecting the signal conditioner to the cable; and connecting the cable to the vehicle. The data will be recorded during entry and played back after landing.

Crew Equipment

The normal complement of crew equipment will provide supplies for a standard crew of four for a mission of 7 days. The equipment is designed to be used in the Orbiter shirt-sleeve environment by 90 percent of the male/female population (the 5th to 95th percentile). All the equipment with the exception of the flashlight is designed for use only inside the pressurized crew compartment of the Orbiter. The flashlight is also designed to operate while on extravehicular activity. The survival kit and lifevest are designed to remain completely functional following an abort landing.

Clothing.— The Orbiter crew clothing will be issued on a standard sizing schedule to fit the male/female crew. All clothes with the exception of underwear are common to both sexes. Cotton-blended tube socks are provided for all crewmembers. Clothing for Shuttle flights is listed in table 5-IV. All clothing will be made of commercially available fabrics. With routine maintenance and repair, the useful life of the clothing is expected to be 30 operational missions based on a nominal mission duration of 7 days. All clothing will be recycled between missions for use by crewmembers of equivalent size. A 7-day mission clothing set for one crewmember will not exceed 10 kilograms (22 pounds).

Personal hygiene kit.— The personal hygiene kit is designed to support a crewmember's personal hygiene requirements for a standard mission lasting 7 days. The kit contains a razor, shaving cream, a styptic pencil, skin emollient, stick deodorant, nail clippers, comb and brush, dental floss, toothbrush, toothpaste, antichap lip balm, and soap. Standard products are expected to be used in the kits, but each crewmember will be allowed to make a limited personal selection of alternate commercial preparations and optional kit components (limited to readily available off-the-shelf items).

Miscellaneous provisions.— The crew will also have both paper and cloth towels suitable for general-purpose dry utility wipes, or, when wet, suitable for washcloths for shaving, cleansing, and other similar tasks. Trash containers will be provided for temporary stowage of waste materials.

The crew will be provided with a Swiss Army-type pocketknife, scissors, sunglasses, a chronograph, a sleeping mask, sleeping earplugs, general-purpose adhesive tape, a Velcro kit, in-flight restraining devices, a Mylar mirror with Velcro attach points, and a small portable desk assembly.

TABLE 5-IV.— SPACE SHUTTLE SHIRT-SLEEVE CLOTHING

Article of clothing	Quantity per crewmember
Early flights	
Shorts	1 pair per day
T-shirts	1 per day
IVA gloves	1 pair per flight
Shoes	1 pair per flight
Constant-wear garment	3 per flight
Jacket	1 per flight
Athletic supporter	4 per flight
Trousers	1 pair per 7 days plus 1 spare per flight
Handkerchiefs	
Shirt	1 per 3 days
Socks	
Operational flights	
Underwear	1 set per day
One-g footwear	1 pair per flight
Jacket	1 per flight
Trousers	1 pair per 7 days plus 1 spare per flight
Shirt	1 per 3 days
Gloves	1 pair per flight
IVA footwear	1 pair per flight
Brassiere	1 per day

Extravehicular Mobility Unit

The extravehicular mobility unit (EMU) comprises the space suit, the life-support subsystem, the displays and controls module, the manned maneuvering unit, and several other crew items designed for extravehicular activity, together with emergency life support and rescue equipment.

The extravehicular mobility concept for Shuttle is more comprehensive than for any other space program, including the highly mobile lunar exploratory missions. Crewmembers must be prepared to exit the spacecraft for inspection of the Orbiter or payload; for photography; for possible manual override of Orbiter or payload systems; for installation, removal, and transfer of film cassettes on payload sensors; for operation of outside equipment; for cleaning optical surfaces; and for repair, replacement, or calibration of modular equipment either on the Orbiter or in the payload bay.

For later missions, crewmembers will reposition themselves and other objects from the Orbiter to locations hundreds of meters distant from the spacecraft. In the event of an emergency resulting in a disabled Orbiter, crewmembers will use the personnel rescue system to safely transport shirt-sleeved colleagues from the disabled craft to the rescue craft.

The extravehicular mobility unit has been designed to accommodate a wide variety of interchangeable systems that interconnect easily and securely and that do not require two-man operation for either normal or emergency use.

Space-suit assembly.— In contrast to the Apollo lunar suit, the Space Shuttle suit costs less and is more flexible. The Shuttle suit is not customized for the wearer; instead, it is fitted from differently sized component parts.

Basic to the extravehicular suit is the liquid cooling and ventilation garment (LCVG), a mesh one-piece suit made of spandex and zippered for front entry. The cooling garment serves to remove metabolic heat produced by the

crewmember and is connected to the primary life-support subsystem, where the heat is actually removed. It also serves to ventilate the limbs. The liquid cooling water and the return air travel through a harness to the inside front of the hard upper torso, where they connect to the life-support subsystem.

The cooling garment is designed to provide cooling during any activity up to and including that which would produce 2.1 MJ/hr (2000 Btu/hr) for 15 minutes, 1.1 MJ/hr (1000 Btu/hr) nominal. The upper limit of 2.1 MJ/hr (2000 Btu/hr) is considered extremely vigorous exercise. Apollo astronauts working on the Moon experienced an average production of approximately 0.9 MJ/hr (850 Btu/hr) with peaks up to about 1.5 MJ/hr (1450 Btu/hr). The cooling rate for the garment is controlled at the cooling control valve on the displays and controls module, which is attached to the front of the hard upper torso.

The foot section consists of specialized socks that contain return-air ports. The crewmember's feet are fitted with boot inserts that fit into the lower torso boots.

The cooling garment weighs 3 kilograms (6.5 pounds) dry and is expected to have a useful life of about 15 years. The airflow in the garment is 0.17 m³/min (6.0 ft³/min). Both the airflow and the waterflow are controlled by the life-support subsystem. The suit will be cleaned and dried after each flight.

Under the cooling garment, the crewmember wears a urine collection device, which receives and stores up to 950 milliliters of urine for transfer to the Orbiter waste management system. The inner clothing ensemble is completed with the addition of the in-suit drink bag, which contains 0.6 liter (21 ounces) of potable water to be used by the crewmember.

The communications carrier assembly, called a "Snoopy Cap," fits over the head and chin of the crewmember and snaps in place with a chinguard. It contains headphones and a microphone for two-way communications and caution-and-warning tones.

A crewmember fitted with the liquid cooling and ventilation garment, the boot inserts, the urine collection device, the in-suit drink bag, the communications carrier assembly, and a biomedical instrumentation subsystem is now ready to fit the space-suit assembly over these garments. The suit is designed for easy donning and doffing in a zero-g environment.

The space suit consists of the hard upper torso, gloves, the lower torso, the helmet, and the extravehicular visor assembly that fits over the helmet. The lower torso is available in various sizes and consists of a waist ring attached to the leg/boots. The hard upper torso is made in five sizes with a matching hard waist ring. Connecting gloves are available in 15 sizes. The helmet is available in only one size.

The suit is easier to don and doff than the Apollo suit because of the hard waist ring. Each component connects by hard snap-ring retainers; there are no zippers.

The hard upper torso has enabled the use of bearings in the shoulder and arm joints, greatly facilitating the crewmember's freedom of movement in those axes. Bending, leaning, and twisting motions of the torso can all be done with relative ease.

All softgoods-to-hardware connections are made with a combination of mechanical joints (sewn, screwed, clamped, etc.) and adhesive bonding.

Materials used in the construction of the suit are designed to prevent fungus or bacteria growth; however, each suit must be cleaned and dried after use.

The entire suit assembly is rated with a 15-year life expectancy. The nominal atmospheric pressure in the suit is 28 kN/m² (4.0 psid); the suit ultimate pressure is 73 kN/m² (10.6 psid). The suit is composed of several bonded layers, beginning with a polyurethane-on-nylon pressure bladder, many Kevlar layers with folded and tucked joints (for mobility), and ending with a Kevlar, Teflon, and Dacron antiabrasion layer. The hard upper torso has an aluminum shell. The total weight of the space-suit assembly and the associated garments is 39 kilograms (85 pounds).

To ensure not only mobility but also freedom of balance, the center of gravity of the suit assembly is within 10 centimeters (4 inches) vertically and 7.6 centimeters (3 inches) horizontally of that of a nude standing crewmember.

The extravehicular visor assembly snaps onto the outside of the helmet and provides protection from micrometeoroids and from ultraviolet and infrared radiation from the Sun.

An electrical harness connects the communications carrier assembly and the biomedical instrumentation subsystem to the hard upper torso where internal connections are routed to the extravehicular communicator. The cable routes signals from the ECG sensors attached to the crewman through the bioinstrumentation system to the extravehicular communicator as well as routing caution-and-warning signals and communications from the communicator to the crew headset.

The extravehicular communicator is a separate subassembly that attaches to the upper portion of the life-support system at the back of the hard upper torso. The controls are located on the displays and controls module mounted at the front of the upper torso. The extravehicular communicator provides radio communication between the suited crewmember and the Orbiter. In addition, ECG information is telemetered through the communicator to the Orbiter.

During the early flights, neither the extravehicular communicator nor the bioinstrumentation system will be used. Instead, a 30.5-meter (100-foot) communications tether will connect the suited crewmember with the Orbiter airlock station. The extravehicular communicator will be used for all operational flights.

The radios for space-walk communications will have two single ultrahigh-frequency channel transmitters, three single-channel receivers, and a switching mechanism. In addition, telemetry equipment will be included so that ground personnel can monitor astronaut heart beat. These backpack radios will have a "low profile" antenna, a 0.3-meter (1-foot) long rectangular block fitted to the top of the packs. The radios will weigh 3.9 kilograms (8.7 pounds) and will be 30.5 centimeters (12 inches) long, 10.9 centimeters (4.3 inches) high, and 8.9 centimeters (3.5 inches) wide.

Portable life-support subsystem.—The function of the portable life-support subsystem (PLSS) is to provide a constantly refreshed atmosphere for crewman breathing and suit pressurization and to remove metabolically produced heat from the crewman through the liquid-cooling and ventilation garment. The system also provides communications for the crewman, light-emitting diode (LED) displays, and a caution-and-warning system for alerting the crewman of any system failure or abnormal condition with the life-support system.

The PLSS is 50.17 centimeters (19.75 inches) deep, 58.4 centimeters (23.0 inches) wide, and 77.0 centimeters (30.3 inches) high and weighs 72.6 kilograms (160 pounds). The rechargeable silver-zinc battery provides 17 volts at 52 W/hr for 7 hours.

The portable life-support subsystem is attached, in modular form, to the back of the hard upper torso. It includes the portable oxygen bottles; water tanks; a fan/separator/pump motor assembly; a sublimator; a contaminant control cartridge; various regulators, valves, and sensors; and a communications, bioinstrumentation, and microprocessor module. The secondary oxygen pack attaches to the bottom of the portable life-support subsystem.

The modular design of the PLSS allows for quick servicing and replacement of components such as the lithium hydroxide bed, which needs to be replaced following each use. Resupply of oxygen and water can be done easily through the service and cooling umbilical, which connects to the Orbiter airlock.

The life-support system contains 0.55 kilogram (1.217 pounds) of oxygen at 5860 kN/m² (850 psia) in the primary oxygen bottles, 1.2 kilograms (2.6 pounds) of oxygen at 41 370 kN/m² (6000 psia) in the secondary pack, and 4.5 kilograms (10 pounds) of water in three water bladders. The primary oxygen system and the water tanks provide enough of these expendables for 7 hours inside the suit, including 15 minutes for checkout, 6 hours for extravehicular activity, 15 minutes for doffing, and 30 minutes for reserve. The secondary oxygen pack will supply oxygen and maintain suit pressure for 30 minutes in the event of a failure in the primary system or depletion of the primary system oxygen.

Oxygen from the system enters the suit at the helmet and flows from behind the head down through the suit. Oxygen and carbon dioxide are removed from the suit through the liquid-cooling and ventilation garment at ports near the crewman's wrists and feet. Return air goes first through the contaminant control cartridge where activated charcoal and lithium hydroxide beds remove carbon dioxide, odors, and dust. From there, the return air goes through a water separator where moisture from crewman exhalation and from the lithium hydroxide/carbon dioxide reaction is removed. The oxygen then goes through the fan where airflow is maintained at 0.17 m³/min (6 ft³/min). Air is then routed through the sublimator, where it is cooled to 302.7 K (29.5° C or 85.1° F), and then passes through a vent/flow detector and back to the suit. Oxygen for the air system is fed from the primary oxygen containers through regulators, which maintain suit pressure at 28.3 kN/m² (4.1 psid).

The system is protected from suit overpressure, primary oxygen supply depletion, or mechanical failure by the use of regulators, sensors, and the secondary oxygen pack. The secondary oxygen pack can maintain suit pressure at 23.79 kN/m² (3.45 psid). A purge valve on the displays and controls module allows a crewmember to completely replace system oxygen in the suit should, for instance, the carbon dioxide level rise too high too quickly.

The cooling water system takes the warm water from the cooling garment and divides it into two loops. One loop goes to the sublimator where the water in that loop is cooled and sent back to the cooling control valve. The other loop goes directly back to the cooling control valve, where the loops are recombined and full flow goes back to the cooling garment. Thus, the cooling garment has a constant flow of cooling water at a temperature set by the crewman using the cooling control valve. During the process, the full flow from the cooling garment goes through a gas separator where gas is removed from the loop and then through a pump that maintains a flow of 118 kg/hr (260 lb/hr). Another side loop circulates 9 kg/hr (20 lb/hr) through the contaminant control cartridge to cool the lithium hydroxide canister since the lithium hydroxide/carbon dioxide reaction produces heat and needs to be kept cool for an efficient reaction.

Since the system is a closed-loop design, water from the water separator is fed back to the water system and air from the gas trap is fed back to the oxygen system. Water from the water tanks is also fed, through regulators, into the cooling system. However, the primary purpose for the water tanks is to feed water to the sublimator. The sublimator works on the principle of sublimation — the process by which a solid turns directly into a vapor, bypassing the liquid phase. In this case, ice is formed on the sublimator evaporator sieve and allowed to vaporize to space, in so doing removing heat with it. Air and cooling water are passed through fins in the sublimator where heat from each system is extracted.

The PLSS sensors detect system airflow, air pressure, waterflow, water pressure, differential water pressure (between the circulating system and the water tanks), water temperature, and carbon dioxide content in the return air. In addition, there are a number of crew-selectable valves including a purge valve, a cooling control valve (infinitely variable), oxygen supply, and a direct-reading air pressure gage. The sensors supply information to the displays and controls module, where a microprocessor maintains an automatic watch over system integrity.

The back of the life-support system has two latch points for mounting the manned maneuvering unit.

Displays and controls module.—The displays and controls module (DCM) is an integrated assembly that attaches directly to the front of the hard upper torso. The module contains a series of mechanical and electrical controls, a microprocessor, and an alphanumeric LED display easily seen by a crewman wearing the space suit.

The function of the displays and control module is to provide the crewman control capability for the PLSS and the secondary oxygen pack and information in the form of a visible and audible status of the PLSS, the suit, and when attached, the manned maneuvering unit.

The mechanical controls consist of a suit purge valve; the liquid-cooling and ventilation garment cooling valve; and the oxygen actuator control, which has four positions: off, IV (which turns primary oxygen on to a 3.4-kN/m² (0.5-psid) suit pressure setting), Press (which turns primary

oxygen on to a 28.3-kN/m² (4.1-psid) suit pressure setting), and EV (which leaves primary oxygen on the 28.3-kN/m² (4.1-psid) setting and turns the secondary oxygen pack on). The electrical controls include a voice communication mode switch; dual volume controls; push-to-talk switches; a power mode switch; feedwater and caution-and-warning switches; and the LED display brightness control. The displays visible on the module are a 12-digit LED display, a built-in test equipment indicator, and an analog suit pressure gage.

The displays and controls module is connected to the hard upper torso and to the PLSS with both internal and external hookups. A multiple function connector hooks the display module to the service and cooling umbilical, enabling the use of the display module controls during suit checkout inside the airlock station.

The display module interacts with a microprocessor in the PLSS that contains a program that enables the crewman to cycle the display through a series of systems checks and thereby determine the condition of a variety of components. The microprocessor monitors oxygen pressure and calculates the time remaining at the crewman's present use rate. It signals an alarm at high oxygen use in the primary oxygen tanks. It also monitors water pressure and temperature in the cooling garment. Carbon dioxide level is monitored and an alarm is signaled at high carbon dioxide concentrations in the suit. The microprocessor monitors the power consumed and signals at high current-drain rates and also at an estimated 30 minutes of battery power left. All the warnings are displayed on the display module LED display.

The display module also has a fiber optic cable that is used when the manned maneuvering unit (MMU) is connected to the extravehicular mobility unit. The fiber optic cable connects the display unit to the manned maneuvering unit. The use of a fiber optic cable is more convenient, more reliable, and safer than an electrical connector for extravehicular applications. When the MMU is connected, the display module also provides a cycled readout of propellant pressures, temperatures, battery condition (in the MMU), and an audible thruster cue. The caution-and-warning system provides low-propellant, low-battery, and failed-component warnings to the crewman.

Manned maneuvering unit.—The manned maneuvering unit (fig. 5-18) is a one-man propulsive backpack that snaps onto the back of the spacesuit's portable life-support system. It allows a suited crewmember to reach many otherwise inaccessible areas outside the Orbiter. In addition, it can be used to support payloads by enabling a crewmember to perform inspections, servicing, adjusting, or repairing onorbit. In the event of a disabled Orbiter, an MMU-fitted crewmember would assist in the rescue of

crewmen trapped in the disabled Orbiter. The MMU will also be used during routine flyaround inspections of the Orbiter. It will probably be used during demonstration space construction projects, although a space taxi is presently envisioned in addition to the MMU. Normally, only one MMU would be carried onboard an Orbiter for extravehicular activity. Two MMU's would be carried onboard a rescue Orbiter or when extensive MMU support is required.

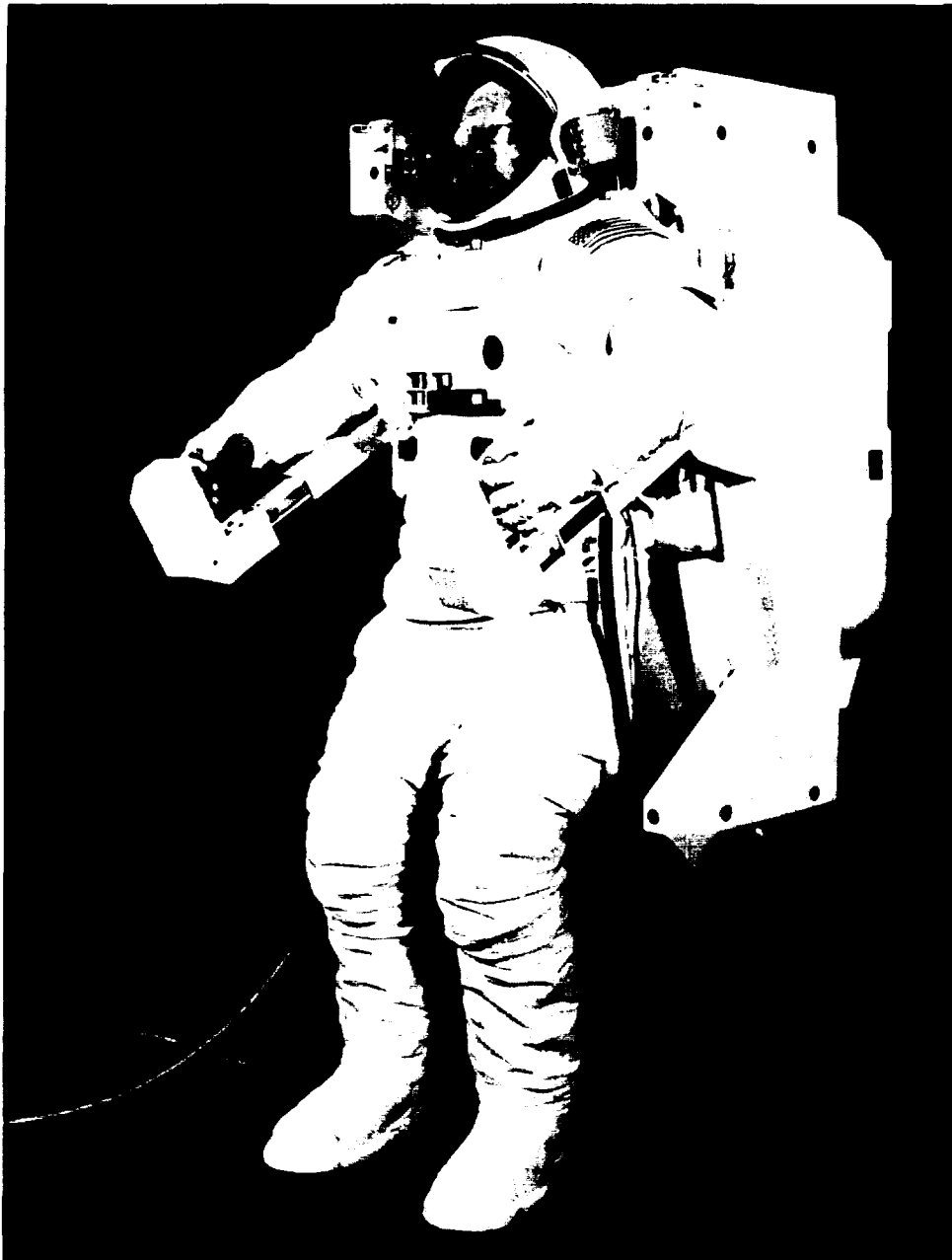

Figure 5-18.—Manned maneuvering unit (NASA S-79-35616).

The manned maneuvering unit owes most of its systems to development stemming from the Skylab M-509 astronaut maneuvering unit (AMU), which was tested in the forward compartment of the Skylab workshop during the three missions in 1973 and 1974.

The MMU attaches to the PLSS on the back of the hard upper torso by means of two capture latches on either side of the MMU, which mate to the life-support system. The latches are designed for ease of entry and feature offset geometry so a crewman can tighten the connection by rocking from side to side, thus forcing the latches to lock tighter. For each unlatching, the MMU has two D-ring cords above the crewmember's head.

The MMU is stowed on an associated flight support station, which is secured to one of the payload bay forward bulkheads. It is stowed in this station both during launch and during orbital activity.

The MMU system is designed to provide EVA support for up to 6 hours before needing nitrogen and battery recharging. The propellant is noncontaminating gaseous nitrogen. The batteries used in the MMU are identical to the battery used in the life-support system; spares fit either system. The batteries can be recharged in flight and the MMU can be recharged with nitrogen from either a separate dedicated system or from the Orbiter nitrogen system.

The reliability of the MMU is guaranteed with a dual parallel system rather than a backup redundant system. In the event of a failure in one parallel system, it would be shut down and the remaining system would be used to return the MMU to the flight support station in the payload bay. Either system provides complete control for a safe return, although at a reduced rate.

Both the propulsion and the control system are arranged in this dual parallel setup. There are dual nitrogen tanks, dual isolation valves, dual regulators, and dual four-corner thruster triads. The control system uses dual batteries and power conditioners, dual control logic circuits, and dual thruster controls. The hand controllers, rate gyros, and attitude control circuits are not paralleled because the hand controllers use dual switches and the other devices are not critical for a safe return.

The MMU provides six degrees of freedom for the crewman using the system. He can rotate about any of three axes (X, Y, and Z) in roll, pitch, and yaw and translate in any of six directions (front to back, left to right, and up to down).

Rotation or translation commands are routed from two hand controllers through a microprocessor to a series of 24 pressurized nitrogen thruster jets. The crewman can input independent or multiple commands for both controllers. The left hand controls translation and the right hand controls rotation. Attitude hold is maintained automatically on selection of a switch on the right-hand controller. Attitude hold is adjustable from $\pm 0.5^\circ$ to $\pm 2.0^\circ$. The inertial drift of the MMU in attitude hold is less than 0.01 deg/sec, or 36 deg/hr.

The acceleration response of the MMU is 10.2 cm/sec-sec (4 in/sec-sec) in translation; 10 deg/sec-sec in rotation. An audio cue sounds whenever a thruster is fired, either manually by the crewman or automatically by the attitude hold system. This thruster cue will provide audio feedback of pilot inputs and also would alert the pilot of a system malfunction, such as a "stuck-on" thruster.

The control logic for the MMU is quite similar to the piloting logic for the Orbiter itself, so astronauts using the MMU will find the response familiar.

The total nitrogen charge carried inside the MMU bottles is equivalent to a translation acceleration of 20 m/sec (66 ft/sec), enough to provide for several routine Orbiter flyarounds, two round-trip Orbiter-to-Orbiter rescue flights, or numerous payload servicing trips. The MMU is recharged under high pressure on the ground; if recharged in flight, the total nitrogen charge would be somewhat less than the 20-m/sec (66-ft/sec) capability because of the lower pressure of the nitrogen system used onboard the Orbiter. Recharging takes place at the MMU flight support station in the payload bay and is easily executed by a single crewman.

The two batteries used on the MMU are designed to be easily replaced at the flight support station with freshly charged batteries. The battery recharge takes 16 hours and is done inside the airlock station.

The MMU contains both attach points and power outlets for equipment such as lights, cameras, and power tools; thus, the MMU serves as a portable space work station.

The MMU control system connects through an LED/fiber-optic cable to the EMU displays and controls module. The LED panel on the display module provides a continuous display of the status of the nitrogen propellants. Battery ampere-hour status is provided on demand. Out-of-limit parameters are signaled through the caution-and-warning system of the display module by an audible cue; an alphanumeric display of the errant parameter is also displayed on the LED panel.

The MMU weighs 102 kilograms (225 pounds); the flight support station weighs 25 kilograms (55 pounds).

EVA support equipment.—In order for an EVA crewman to work in the zero-g environment in the confines of the payload bay, he must be able to translate to the work area, have adequate lighting, and be anchored to provide the required payload operating forces. Special precautions also must be taken to see that tools do not float away.

The EVA support equipment provides these capabilities. It consists of a mini work station, tool caddies, crewman safety tethers, lights, and equipment tethers.

The mini work station provides a universal attachment tether for crewman restraint and carrying locations for the tool caddies.

The tool caddies retain the tools when they are not in use and provide tethers for the tools when they are in use.

Two crewman safety tethers are presently provided, one for inside the airlock when the airlock hatch is open and the other for use in the payload bay when the doors are open.

Two EVA lights are provided for each crewman, one attached to each side of the visor assembly. Each light is removable and can be hand carried, if desired.

Equipment tether restraints and a more rigid crewman tether restraint system may be used for particular mission requirements.

Personal rescue system.—The personal rescue system (fig. 5-19) will provide life-support capability to permit personnel from a disabled Orbiter to be transferred to a rescue Orbiter in a near-Earth space-vacuum environment.

The personal rescue system includes the personal rescue enclosure, the rescue support umbilical, and the portable oxygen system.

The personal rescue enclosure is an inflatable 86-centimeter (34-inch) diameter sphere constructed of gastight, restraint, and thermal protection fabric to provide environmental crew protection.

The rescue support umbilical allows vehicle life-support functions and communications to be used during the pre- and post-rescue modes.

The portable oxygen system is the primary life-support system for the personal rescue system. The outflow from the exhalation valve, consisting of a mixture of oxygen, water vapor, and carbon dioxide, provides the pressurizing gas for the rescue system for a 1-hour rescue period.

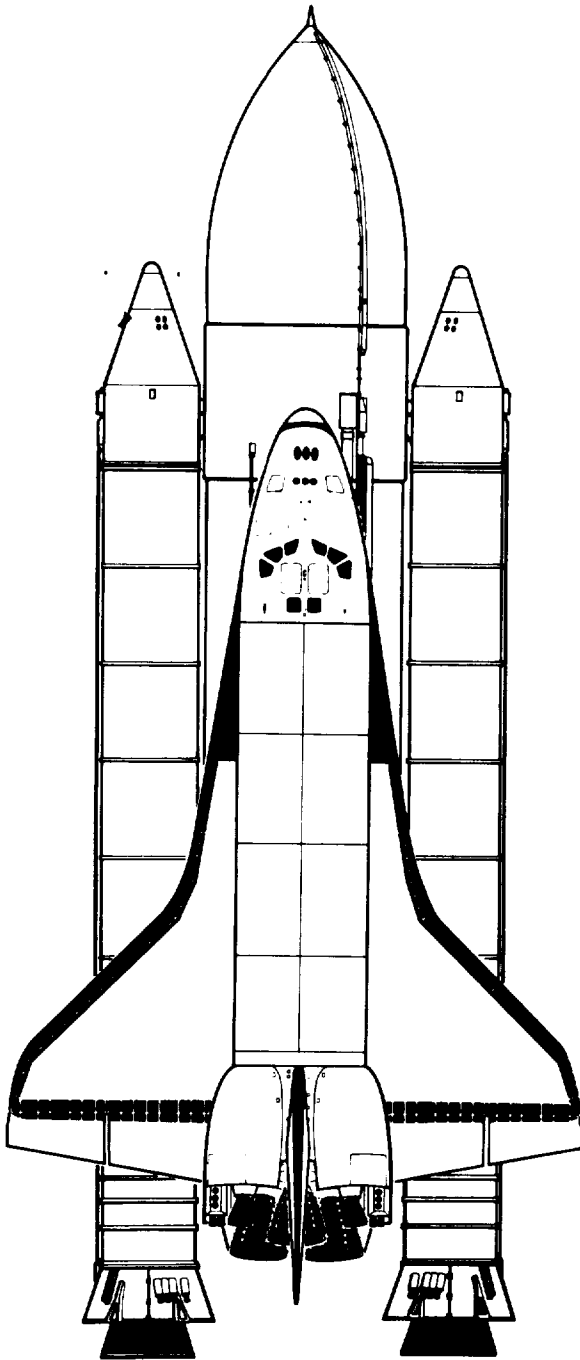

Figure 5-19.—Personal rescue system.

6. MISSION OPERATIONS AND SUPPORT

6. MISSION OPERATIONS AND SUPPORT

Launch and Landing Facilities and Operations



INTRODUCTION.....	6-5
ORBITER PROCESSING FACILITY.....	6-6
VEHICLE ASSEMBLY BUILDING.....	6-7
Solid Rocket Booster Processing and Storage.....	6-8
External Tank Processing and Storage.....	6-9
Orbiter Processing.....	6-10
Space Shuttle Vehicle Processing.....	6-10
LAUNCH CONTROL CENTER.....	6-10
LAUNCH PROCESSING SYSTEM.....	6-10
MOBILE LAUNCHER PLATFORM.....	6-11
CRAWLER-TRANSPORTER.....	6-14
LAUNCH PADS 39-A AND 39-B.....	6-15
Fixed Service Structure.....	6-16
Rotating Service Structure.....	6-18
Flame Deflector System.....	6-21
Sound-Suppression Water System.....	6-21
Liquid Oxygen System.....	6-22
Liquid Hydrogen System.....	6-22
LAUNCH PAD/LAUNCH PROCESSING INTERFACE.....	6-23
HYPERGOL MAINTENANCE AND CHECKOUT FACILITY.....	6-23
LAUNCH EQUIPMENT TEST FACILITY.....	6-23
PAYLOAD PROCESSING FACILITIES AND SUPPORT EQUIPMENT.....	6-23
Payload Canister Transporter.....	6-25
Payload Strongback.....	6-26
Horizontal Cargo Processing.....	6-26
OPERATIONS AND CHECKOUT BUILDING.....	6-27
Spacelab Assembly and Test Area.....	6-27
Spacelab Processing.....	6-27
PAYLOAD INSTALLATION IN ORBITER PROCESSING FACILITY.....	6-28
ORBITER OPERATIONS FROM OPF TO LAUNCH PAD.....	6-28
LAUNCH PAD SERVICING.....	6-28
VERTICALLY INTEGRATED PAYLOADS.....	6-28
PAYLOAD PROCESSING VARIATIONS.....	6-29
MISCELLANEOUS FACILITIES AND EQUIPMENT.....	6-30
Mate/Demate Stiffleg Derrick.....	6-30
Towing Tractor.....	6-30
LAUNCH OPERATIONS.....	6-31
SHUTTLE LANDING FACILITY.....	6-32
LANDING SYSTEM.....	6-34
LANDING OPERATIONS.....	6-35
SOLID ROCKET BOOSTER RECOVERY.....	6-38
Solid Rocket Booster Retrieval and Processing.....	6-38
Solid Rocket Booster Disassembly Facility.....	6-39
Parachute Refurbishment Facility.....	6-41

Briefly...

The Space Shuttle Orbiter will be launched from and landed at either the Kennedy Space Center on the east coast or the Vandenberg Air Force Base on the west coast. Two Orbiters can be processed simultaneously at the new facility at KSC. The final countdown for a Shuttle launch at KSC will require only 2.5 hours, a significant drop from the 28 hours required for Apollo launches. The Orbiters are guided automatically to safe landings on a runway that is roughly twice as long and twice as wide as average commercial landing strips; the speed at touchdown is about 346 km/hr (215 mph).

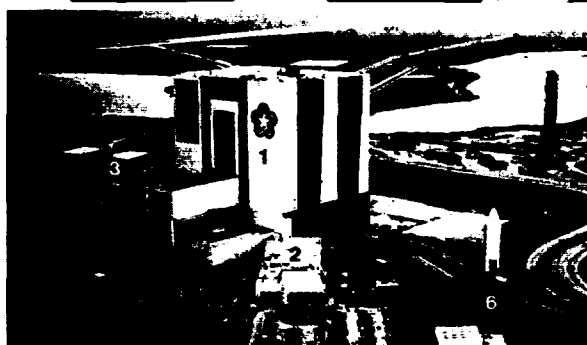
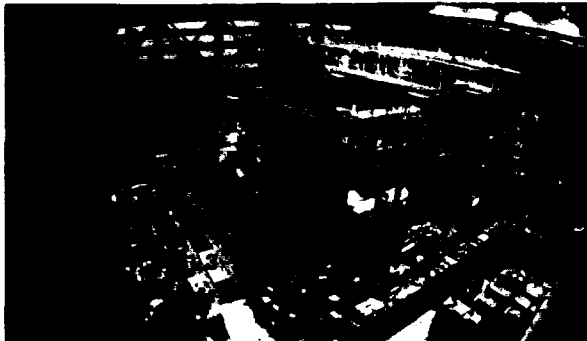

- 1 VEHICLE ASSEMBLY BUILDING**
3.3-hectare (8-acre) ground area
160 meters (525 feet) tall
218 meters (716 feet) long
158 meters (518 feet) wide
3 665 000-cubic-meter
(129 428 000-cubic-foot) volume
- 2 LAUNCH CONTROL CENTER**
24 meters (77 feet) tall (4 stories)
115 meters (378 feet) long
55 meters (181 feet) wide
- 3 ORBITER PROCESSING FACILITY**
29 meters (95 feet) tall
121 meters (397 feet) long
71 meters (233 feet) wide
- 4 SHUTTLE LANDING FACILITY**
4572 meters (15 000 feet) long with
305-meter (1000-foot) safety
overruns at each end
91 meters (300 feet) wide
- 5 MOBILE LAUNCHER PLATFORM**
7.6 meters (25 feet) tall
49 meters (160 feet) long
41 meters (135 feet) wide
Weight of platform: 3 733 000 kilograms (8 230 000
pounds)
Weight with Shuttle dry: 4 989 500 kilograms
(11 000 000 pounds)
Weight with Shuttle wet: 5 761 000 kilograms
(12 700 000 pounds)
- 6 CRAWLER-TRANSPORTER**
6 meters (20 feet) tall
39.9 meters (131 feet) long
34.7 meters (114 feet) wide
2 721 000 kilograms (6 million pounds)
Speed:
Unloaded 3.2 km/hr (2 mph)
Loaded 1.6 km/hr (1 mph)
- 7 LAUNCH PAD AREA**
67 hectares (165 acres)

6. MISSION OPERATIONS AND SUPPORT

Launch and Landing Facilities and Operations

INTRODUCTION

The NASA John F. Kennedy Space Center (KSC) is responsible for prelaunch checkout, for launch of the Space Shuttle and its payloads, and for ground turnaround and support operations. This responsibility extends to Space Transportation System (STS) operations capability development, including the construction and maintenance of STS payload and flight element processing facilities and the development of ground operations management systems and plans, processing schedules, and logistics systems and their use in support of the STS and payloads. It also extends to the establishment of NASA requirements for facilities and ground operations support at Vandenberg Air Force Base (VAFB) in California and designated contingency landing sites. The Kennedy Space Center will also support the Department of Defense in the development and verification of requirements for ground operations at Vandenberg and will maintain NASA facilities and ground support equipment at the California launch site.

The launch facilities of Launch Complex 39 (LC-39) and the technical support base of KSC's Industrial Area were carved out of virgin savanna and marsh in the early 1960's as the departure point for the Apollo Program manned explorations of the Moon. Twelve manned and unmanned Saturn V/Apollo missions were launched from Complex 39 between November 9, 1967, and December 7, 1972. Minimal modifications to LC-39 permitted the launch of both the smaller Saturn IB and the much larger Saturn V. The Skylab space station was placed in a 435-kilometer (270-mile) high circular orbit by a

Saturn V launch vehicle on May 14, 1973, and three Apollo spacecraft with three-man crews were launched by Saturn IB's on May 26, July 28, and November 16, 1973. The Saturn/Apollo era ended on July 15, 1975, with the launch of a Saturn IB/Apollo and its three-man crew as the U.S. contribution to a joint mission with the Soviet Union.

In reshaping the Kennedy Space Center for the Space Shuttle, planners took maximum advantage of existing buildings and structures that could be modified, scheduling new ones only when a unique requirement existed. The only major totally new facilities required to support the Space Shuttle were the Shuttle Landing Facility and the Orbiter Processing Facility.

Kennedy Space Center is located at latitude 28.5° N and longitude 80.5° W. It occupies an area of approximately 56 700 hectares (140 000 acres) of land and water. This area, with the adjoining water bodies, provides sufficient expanse to afford adequate safety to the surrounding communities for Shuttle launch and landing activities.

Space Shuttle launches will be conducted either from KSC or from Vandenberg Air Force Base in California; the initial launches will be made from the Florida facility. Figure 6-1 shows the various orbital inclinations and the related launch azimuths for each site. Together, these capabilities will satisfy all known future requirements.

Payloads as heavy as 29 500 kilograms (65 000 pounds) can be launched due east from KSC into an orbit of 28.5° inclination. Payloads of as much as 14 500 kilograms (32 000 pounds) can be launched from VAFB into the highest inclination orbit of 104°. Polar orbit capabilities up to 18 000 kilograms (40 000 pounds) can be achieved from Vandenberg.

Shuttle operations at KSC will continue and improve upon the mobile launch concept introduced for the Apollo Program. Using the mobile concept, the space vehicle is thoroughly checked out in an enclosed building before it is moved to the pad for final preparations. This method provides greater protection of flight hardware from the elements, more systematic checkout processing using computer techniques, and minimal pad time.

Operations in facilities at LC-39, at the KSC Industrial Area, and at the Cape Canaveral Air Force Station (CCAFS) will be conducted with a smoothness of flow that will permit rapid Orbiter landing-to-launch processing when the Space Transportation System becomes operational in the 1980's.

Space-Shuttle-related facilities at LC-39, and elsewhere at KSC and CCAFS, and their operational functions are described in this section of the document.

ORBITER PROCESSING FACILITY

Space Shuttle Orbiters will be processed between missions in a structure analogous to a sophisticated aircraft hangar—the Orbiter Processing Facility (OPF). Once the Space Transportation System becomes fully operational, the Orbiter Processing Facility will be capable of handling two Orbiters simultaneously. The OPF is located on the west side of the Vehicle Assembly Building (VAB) in order to minimize Orbiter towing distance as the processing flow continues.

The Orbiter Processing Facility (fig. 6-2) consists of two identical high bays connected by a low bay. Each high bay is 60 meters (197 feet)

long, 46 meters (150 feet) wide, and 29 meters (95 feet) high. Each bay has an area of 2700 square meters (29 000 square feet) and is equipped with two 27-metric-ton (30-ton) bridge cranes with a hook height of approximately 20 meters (66 feet).

The low bay separating the two high bays is 71 meters (233 feet) long, 30 meters (97 feet) wide, and 7.5 meters (24.6 feet) high. A 930-square-meter (10 000-square-foot) annex is located on the north side of the facility.

In the high bays, an underfloor trench system contains electrical, electronic, communication, instrumentation, and control cabling; hydraulic supply and return piping; gaseous nitrogen, oxygen, and helium piping; and compressed air distribution piping. Gaseous nitrogen, helium, and compressed air are supplied from the system in the Vehicle Assembly Building.

The low bay houses areas for electronic equipment, mechanical and electrical equipment shops, thermal protection system repair, and self-contained atmospheric pressure ensemble (SCAPE) suiting. It also includes provisions for a communications room, offices, and supervisory control rooms.

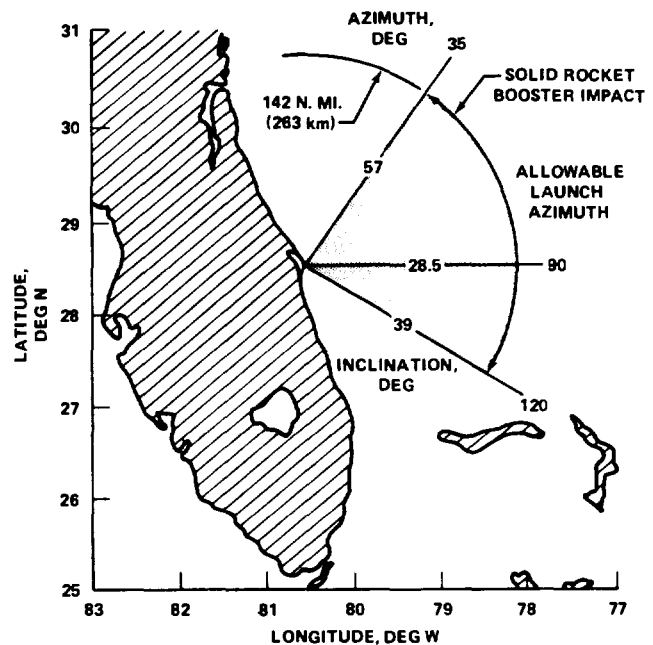
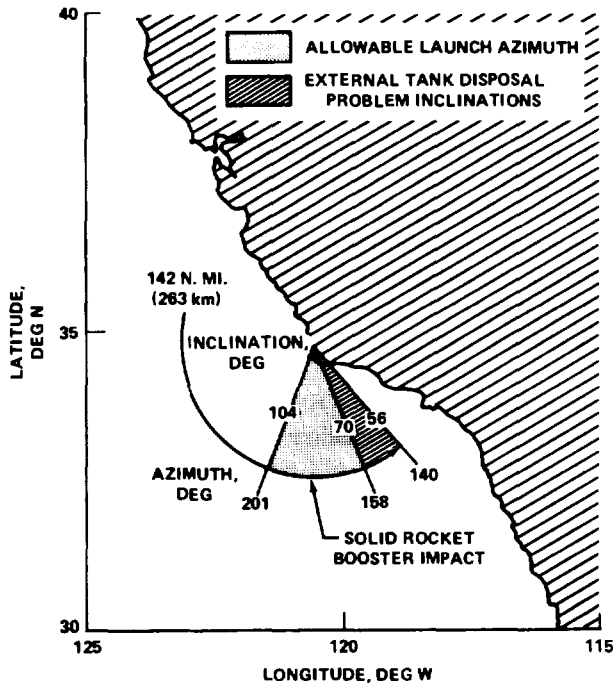

Figure 6-1.—Orbit inclinations and launch azimuths from VAFB and KSC.

The high-bay area has an emergency exhaust system in case of a hypergolic fuel spill. Fire protection systems are provided in both high bays and in the low bay.

VEHICLE ASSEMBLY BUILDING

The Vehicle Assembly Building (fig. 6-3) — built for the vertical assembly of the Saturn vehicles used in the Apollo, Skylab, and Apollo-Soyuz programs — is the heart of Launch Complex 39. With modifications, it will be used in assembling the Shuttle vehicle.

One of the largest buildings in the world, the Vehicle Assembly Building covers a ground area of 3.3 hectares (8 acres) and has a volume of

3 665 000 cubic meters (129 428 000 cubic feet). It is 160 meters (525 feet) tall, 218 meters (716 feet) long, and 158 meters (518 feet) wide. The building is divided into a high-bay area 160 meters (525 feet) tall and a low-bay area with a height of 64 meters (210 feet). A transfer aisle running north and south connects and transects the two bays, permitting the easy movement of vehicle stages.

The high-bay area is divided into four separate bays. The two on the west side of the structure—Bays 2 and 4—are used for processing Solid Rocket Booster (SRB) motors and the External Tank (ET). The two bays facing east—Bays 1 and 3—are used for the vertical assembly of Space Shuttle vehicles atop Mobile Launcher Platforms.

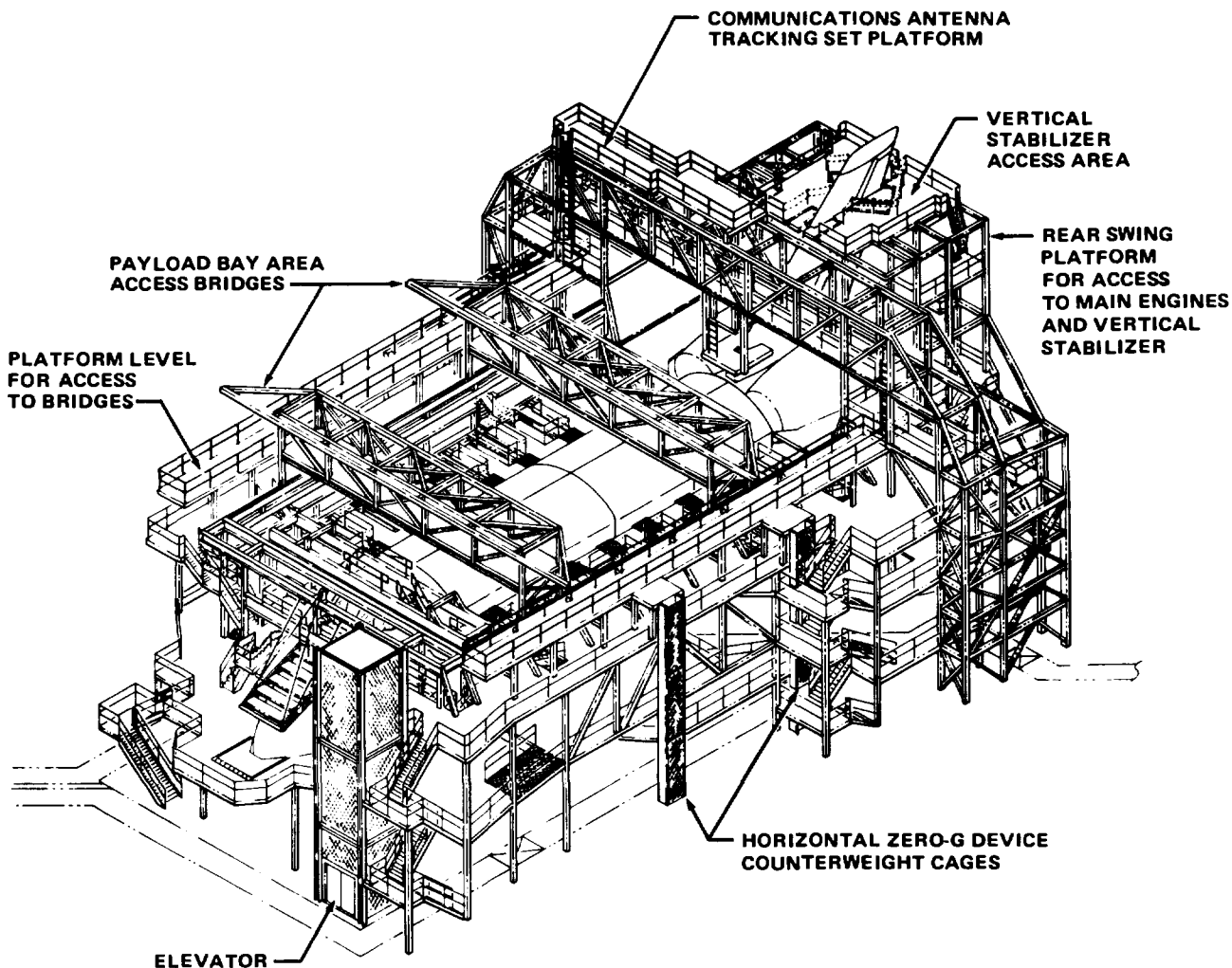

Figure 6-2.—Orbiter Processing Facility.

Extendable platforms, modified to fit the Shuttle configuration, will move in around the vehicle to provide access for integration and final testing. When checkout is complete, the platforms will move back and the doors will be opened to permit the Crawler-Transporter to move the Mobile Launcher Platform (MLP) and assembled Shuttle vehicle to the launch pad. The high-bay door openings are 139 meters (456 feet) high. The lower door opening is 46 meters (152 feet) wide and 35 meters (114 feet) high with four door leaves that move horizontally. The upper door opening is 104 meters (342 feet) high and 23 meters (76 feet) wide with seven door leaves that move vertically.

The low bay will be the site for a Refurbishment and Subassembly Facility (RSF) for SRB segments. Existing pneumatic, environmental control, light, and water systems have been modified in both bays. The north doors to the VAB transfer aisle have also been widened 12 meters

(40 feet) to permit entry of the towed Orbiter from the Orbiter Processing Facility. The doors are slotted at the center to accommodate the Orbiter's vertical stabilizer.

The Vehicle Assembly Building has more than 70 lifting devices, including two 227-metric-ton (250-ton) bridge cranes.

Solid Rocket Booster Processing and Storage

The solid rocket motor segments and associated hardware will be shipped to KSC by rail from the contractor facility in Utah. The segments will be transported horizontally and will have transportation covers. End rings will provide segment handling points, environmental protection, and protection of the solid grain propellant and the outer edge of each segment from potential impact damage.

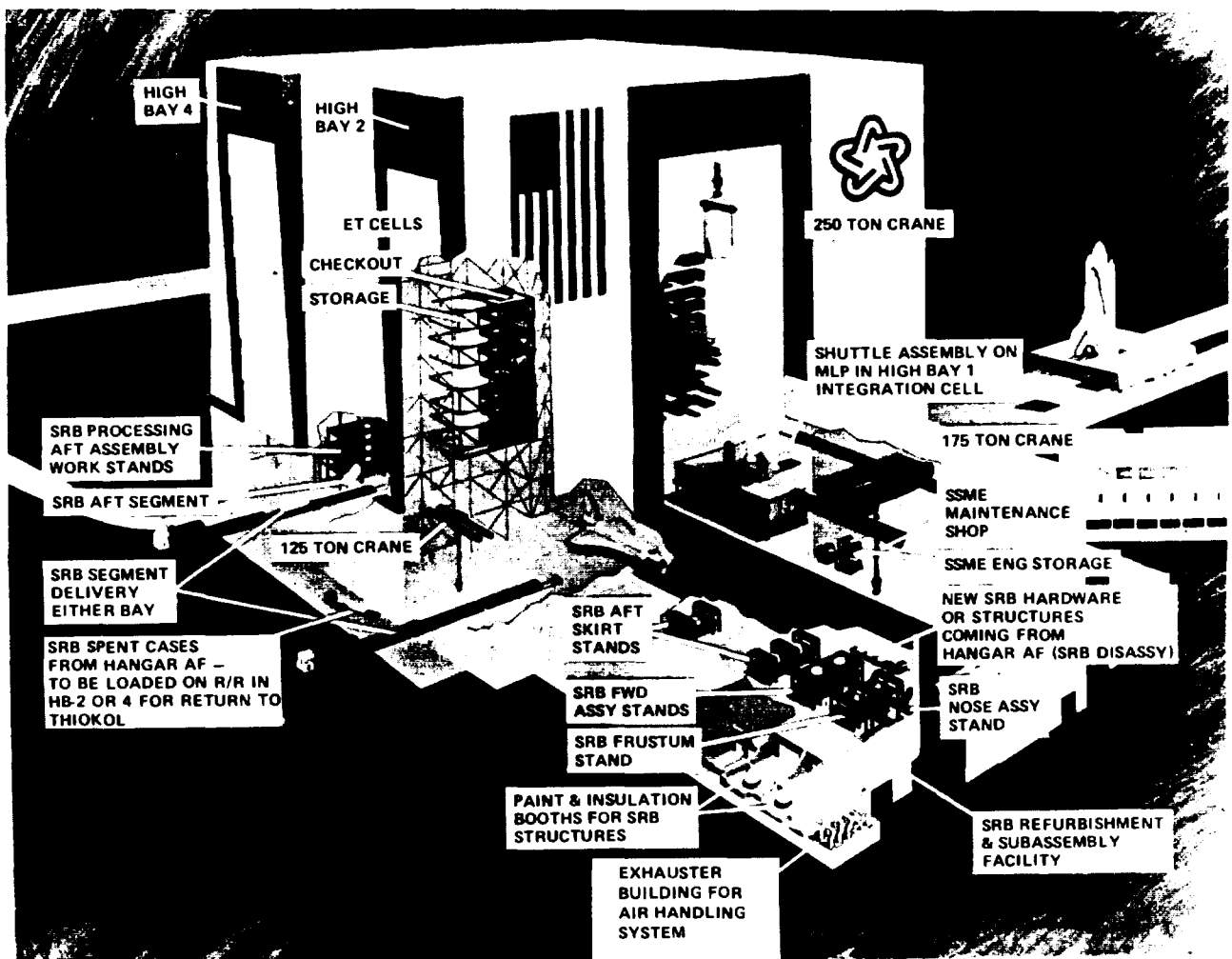

Figure 6-3.—Vehicle Assembly Building (108-KSC-78P-159).

On arrival at KSC, the segments will first be moved into High Bay 4 for transportation cover removal and offloading. They are then placed vertically into buildup workstands or in-process areas. The SRB segments, forward and aft closures, nozzle assemblies, nozzle extensions, and associated hardware will be given receiving inspections. Inert SRB elements such as forward skirts, frustums, nose caps, recovery systems, electronics and instrumentation components, and elements of the thrust vector control system will be received in the VAB Refurbishment and Subassembly Facility located in the low bay.

The structural assemblies and components required to build up the nose assembly, the frustum assembly, the forward and aft skirts, and the ET attachment hardware will be shipped to KSC and put into storage or routed to the VAB low bay for buildup.

As the program matures, recovered hardware will be routed to the Refurbishment and Subassembly Facility for reuse. Assembly and checkout of the SRB forward skirt and nose assembly and the aft skirt assembly will also be performed in the RSF. When completed, the aft skirt assemblies will be transferred to High Bay 4 for assembly with the aft solid rocket motor segments.

The stacking of the SRB major assemblies will begin after the buildup of the aft booster assemblies in High Bay 4, the assembly and checkout of the forward nose skirt assemblies in the RSF, and the alinement of the MLP support posts. The stacking operation will be accomplished in the following sequence.

1. The aft booster assemblies will be transferred from the buildup area in High Bay 4 to the High Bay 1 or 3 integration cells and attached to the MLP support posts.
2. Continuing serially, the aft, forward center, and forward rocket motor segments will be stacked to form complete solid rocket motor assemblies.

An alinement check of the complete flight set of SRB assemblies will be performed after the stacking operations are completed. Integrated

and automated systems testing of the assembled Solid Rocket Boosters will be accomplished on the Mobile Launcher Platform, using the launch processing system (LPS) to supply ET/Orbiter simulation.

External Tank Processing and Storage

The External Tank will be transported to KSC by barge from the Michoud Assembly Facility at New Orleans, Louisiana. On arrival at KSC, the tank and the associated hardware will be offloaded. The External Tank will be transported horizontally to the Vehicle Assembly Building where it will be transferred to a vertical storage or checkout cell. In the Shuttle's operational phase, High Bays 2 and 4 will each contain one storage and one checkout cell. Initial operations will be in High Bay 4.

The storage cells provide only the minimum access and equipment required to secure the External Tank in position. After transfer to the checkout cell, both permanent and mobile platforms will be positioned to provide access to inspect the tank for possible damage in transit and to remove hoisting equipment. The liquid oxygen and liquid hydrogen tanks will then be sampled and will receive a blanket pressure of gaseous nitrogen and gaseous helium, respectively, in preparation for a normal checkout.

The ET subsystems checkout includes an inspection of the external insulation and connection of ground support equipment (including the launch processing system) to the appropriate interfaces. Electrical, instrumentation, and mechanical function checks and tank and line leak checks will be performed in parallel.

After satisfactory checkout of the ET subsystems, ground support and LPS equipment will be removed and stored and ET closeout will be initiated. Forward hoisting equipment will be attached and work platforms stored—or opened—in preparation for transfer to the Mobile Launcher Platform.

The External Tank will be hoisted vertically from the checkout cell with the 227-metric-ton (250-ton) high-bay crane and transferred to a Mobile Launcher Platform in High Bay 1 or 3 for mating with the Space Shuttle vehicle's twin Solid Rocket Boosters. After ET/SRB mating, the integration cell ground support equipment will be connected and intertank work platforms will be installed.

Orbiter Processing

The Orbiter will be towed into the transfer aisle through the north door of the VAB. Once in position, the lifting beams will be installed and the erection slings attached. The Orbiter is then lifted, with the landing gear retracted. The Orbiter will be rotated from the horizontal to the vertical position using the 227- and 159-metric-ton (250- and 175-ton) cranes. It is then transferred to the Shuttle assembly area in High Bay 1 or 3 and lowered and mated to the External Tank, which has previously been mated with the Solid Rocket Boosters on the Mobile Launcher Platform. After mating is complete, the erection slings and the load beams will be removed from the Orbiter and the platforms and stands will be positioned for Orbiter/ET/SRB access. The Orbiter will be mated in the VAB with its fin toward the transfer aisle (toward the south at the pad).

Space Shuttle Vehicle Processing

After the Orbiter has been mated to the ET/SRB assembly and all umbilicals have been connected, an electrical and mechanical verification of the mated interfaces will be performed to verify Shuttle vehicle interface compatibility. A Shuttle interface test will be performed using the launch processing system to verify Shuttle vehicle interfaces and Shuttle vehicle-to-ground interfaces. The launch processing system will be used to control and monitor Orbiter systems as required in the Shuttle vehicle assembly and checkout station. After interface testing is complete, ordnance is installed and connected before the Orbiter is transferred to the pad.

Complete external access to the Shuttle vehicle will be provided in the VAB. Payload access will

be limited to access provided internal to the Orbiter through the crew compartment; the payload bay doors will not be opened in the Vehicle Assembly Building.

LAUNCH CONTROL CENTER

If the Vehicle Assembly Building is the heart of LC-39, the Launch Control Center (LCC) is its brain. The Launch Control Center is a four-story structure located on the southeast side of the VAB and connected to it by an enclosed utilities bridge. No changes will be made to the exterior of the Launch Control Center to adapt it for Shuttle operations.

On the inside, Firing Rooms 1 and 2 have been equipped with the highly automated launch processing system designed for Shuttle checkout and launch (fig. 6-4). Firing Rooms 3 and 4 will not be directly concerned with Shuttle operations at this time. Compared to a firing room manned for a Saturn/Apollo launch, a Space Shuttle firing room will be a lonely place: launch with the Shuttle launch processing system will require approximately 45 operational personnel—one-tenth of the 450 needed for an Apollo launch.

LAUNCH PROCESSING SYSTEM

The launch processing system will automatically control and perform much of the Space Shuttle vehicle checkout while the vehicle components are being prepared for launch. It will also provide the capability for work order control and scheduling and will conduct countdown and launch operations. The final countdown will require approximately 2.5 hours, compared to 28 hours for a Saturn/Apollo countdown.

During systems-to-vehicle integration, the launch processing system will interface with the Solid Rocket Booster, the External Tank, the Space Shuttle Main Engines (SSME's), and the Orbiter systems. LPS hardware interface modules will be located in areas such as the Orbiter Processing Facility, the VAB high bays, the Hypergol Maintenance Facility, and various other sites that support Shuttle maintenance and checkout.

The launch processing system has been divided into the central data subsystem (CDS) and the checkout, control, and monitor subsystem (CCMS). The central data subsystem consists of two large-scale computers (Honeywell H-6680) that store test procedures, vehicle processing data, a master program library, historical data, pre- and post-test data analyses, and other data. The CDS is located on the second floor of the Launch Control Center. The checkout, control, and monitor subsystem consists of consoles, minicomputers, a large mass storage unit, and related equipment and is located on the third floor in the firing rooms that will be used to actually process and launch the vehicle. Vehicle checkout, countdown, and launch will be conducted with the support of the information sorted in the CDS.

Automatic checkout from the firing rooms will be accomplished by using computer programs to monitor and record the prelaunch performance of all electrical and mechanical systems. Command signals from the LPS computer will be sent to the various components and test circuits. While a component is functioning, a sensor will measure



Figure 6-4.—Firing Room 1 in the Launch Control Center at KSC (108-KSC-78PC-408).

its performance and send these data back to the LPS for comparison with the checkout limits stored in the system's computer memory. (Certain test requirements and limits are established for each component and stored in the LPS memory.) When the checkout program is complete, a signal will indicate whether or not its performance has been satisfactory. If unsatisfactory, the LPS computer will then provide data that support isolation of the fault. This process will continue through vehicle checkout.

MOBILE LAUNCHER PLATFORM

The Mobile Launcher Platform is a transportable launch base for the Space Shuttle. Two platforms are now available for Launch Complex 39 and the capability exists to add a third. The MLP's are mobile launchers used for Saturn/Apollo missions that have undergone major changes to adapt them for Shuttle. The most striking visual change is the removal of the 121-meter (398-foot) high tower and its hammerhead crane that soared up from the launch platform. The addition of a permanent launch tower (the fixed service structure) at each of the two launch pads has eliminated the need for towers on the Mobile Launcher Platforms.

The Mobile Launcher Platform (fig. 6-5) is a two-story steel structure 7.6 meters (25 feet) high, 48.8 meters (160 feet) long, and 41.1 meters (135 feet) wide. The platform is constructed of welded steel up to 15.2 centimeters (6 inches) thick. At their park site north of the VAB, in the VAB high bays, and at the launch pad, the Mobile Launcher Platforms rest on six 6.7-meter (22-foot) tall pedestals.

The single 13.7-meter (45-foot) square opening in the center of the Apollo mobile launchers that allowed hot exhausts from the Saturn V/IB to escape into the flame trench during lift-off has been replaced by three openings in the MLP—two for SRB exhaust and one for SSME exhaust (fig. 6-6). The SRB exhaust holes are 12.8 meters (42 feet) long and 6 meters (20 feet) wide. The SSME exhaust opening is 10.4 meters (34 feet) long and 9.5 meters (31 feet) wide.

Inside the platform are two levels with rooms and compartments housing LPS hardware interface modules, system test sets, propellant loading equipment, and electrical racks.

Unloaded, the Mobile Launcher Platform weighs 3 733 000 kilograms (8.23 million pounds). The total weight with an unfueled Space Shuttle aboard is 4 989 500 kilograms (11 million pounds); the total weight with the propellant-laden Shuttle aboard is 5 761 000 kilograms (12.7 million pounds).

The Space Shuttle vehicle is supported and restrained on the Mobile Launcher Platform during assembly, transit, and pad checkout by the SRB support/holdown system. Four conical hollow supports for each Solid Rocket Booster are located in each SRB exhaust well. The supports are 1.5 meters (5 feet) high and have a base diameter of 1.2 meters (4 feet).

Two tail service masts (TSM's), one located on each side of the SSME exhaust hole, support the

fluid, gas, and electrical requirements of the Orbiter's liquid oxygen and liquid hydrogen aft umbilicals. The TSM assembly also protects the ground half of those umbilicals from the harsh launch environment. At launch, the SRB ignition command fires an explosive link allowing a 9072-kilogram (20 000-pound) counterweight to fall, pulling the ground half of the umbilicals away from the Space Shuttle vehicle and causing the mast to rotate into a blastproof structure. As it rotates backward, the mast triggers a compressed gas thruster, causing a protective hood to move into place and completely seal the structure from the SSME exhaust.

Other MLP systems include the hydrogen burnoff system and the post-shutdown engine deluge system.

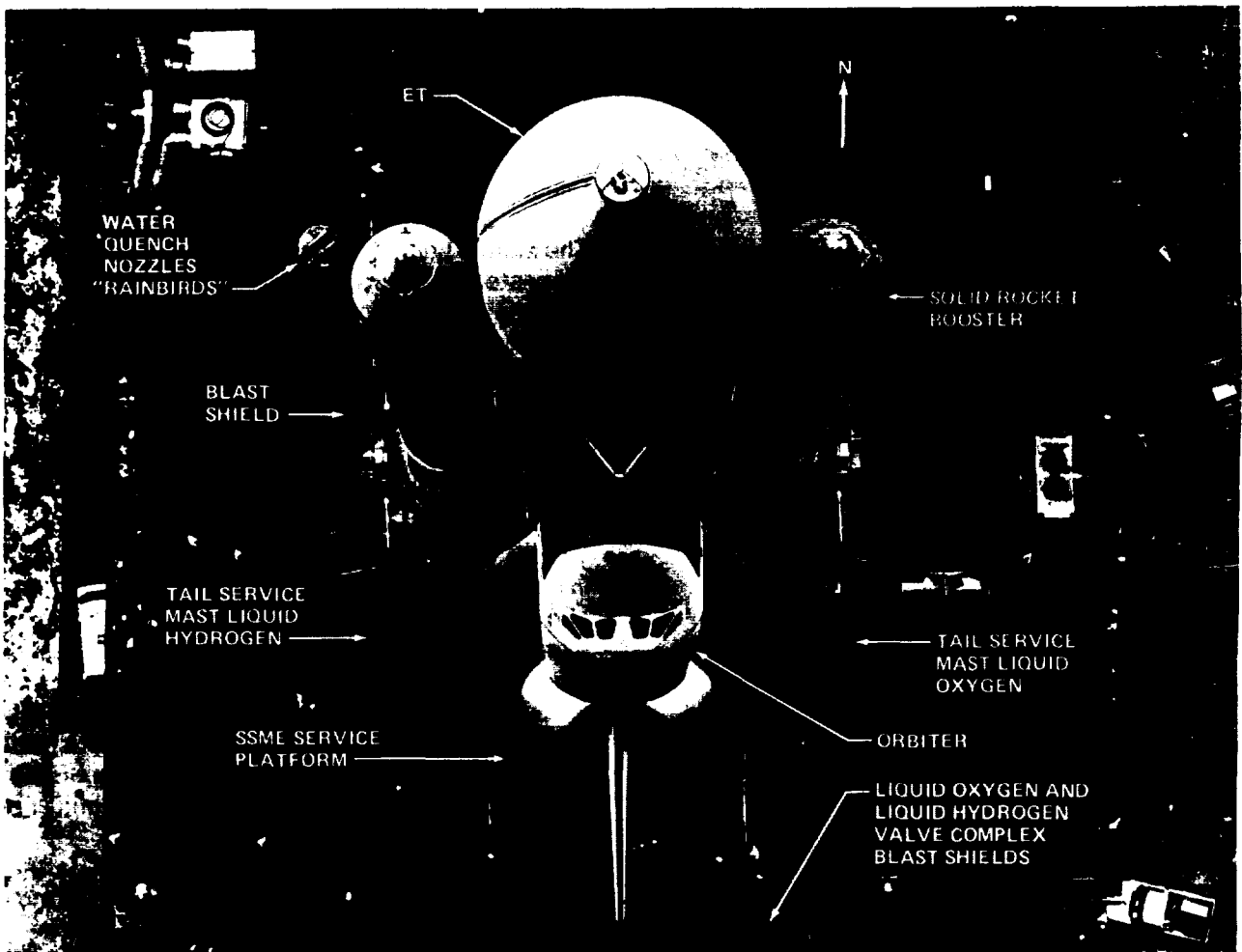

Figure 6-5.—Mobile Launcher Platform (108-KSC-79P-153).

Work platforms used in conjunction with the MLP provide access to the SSME nozzles and to the Solid Rocket Boosters after erection in the Vehicle Assembly Building or while the Space Shuttle is undergoing checkout at the pad.

The Orbiter engine service platform is positioned beneath the MLP and raised by a winch mechanism through the exhaust hole to a position directly beneath the three engines. An elevator platform with a cutout may then be extended upward around the engine bells. The Orbiter engine service platform is 10.4 meters (34 feet) long and 9.4 meters (31 feet) wide. Its retracted height is 3.7 meters (12 feet) and the extended height is 5.5 meters (18 feet). The weight is 27 200 kilograms (60 000 pounds).

Two SRB service platforms provide access to the SRB nozzles after the vehicle has been erected on the Mobile Launcher Platform. The platforms are raised from storage beneath the MLP into the SRB exhaust holes and hung from brackets by a tumbuckle arrangement. The SRB platforms are 1.2 meters (4 feet) high, 6 meters (20 feet) long, and 6 meters (20 feet) wide. Each weighs 4500 kilograms (10 000 pounds).

The Orbiter and SRB service platforms are moved down the pad ramp to a position outside the exhaust area before launch.

CRAWLER-TRANSPORTER

The two Crawler-Transporters used to move the Space Shuttle are the same tracked vehicles previously used to move Saturn/Apollo/Skylab flight hardware between the facilities of Launch Complex 39. They have been refurbished to carry the assembled Space Shuttle on its Mobile Launcher Platform between the VAB and LC-39's two launch pads. Modifications consisted primarily of replacing outdated electronic and electrical equipment. Both massive vehicles are expected to perform their Shuttle transportation functions throughout the duration of the program.

The transporters (fig. 6-7) are 39.9 meters (131 feet) long and 34.7 meters (114 feet) wide. They move on four double-tracked crawlers, each 3 meters (10 feet) high and 12.5 meters (41 feet) long. Each shoe on the crawler track weighs 0.9 metric ton (2000 pounds). The maximum speed unloaded is 3.2 km/h (2 mph); loaded speed is 1.6 km/h (1 mph). The unloaded weight is 2 721 000 kilograms (6 million pounds).

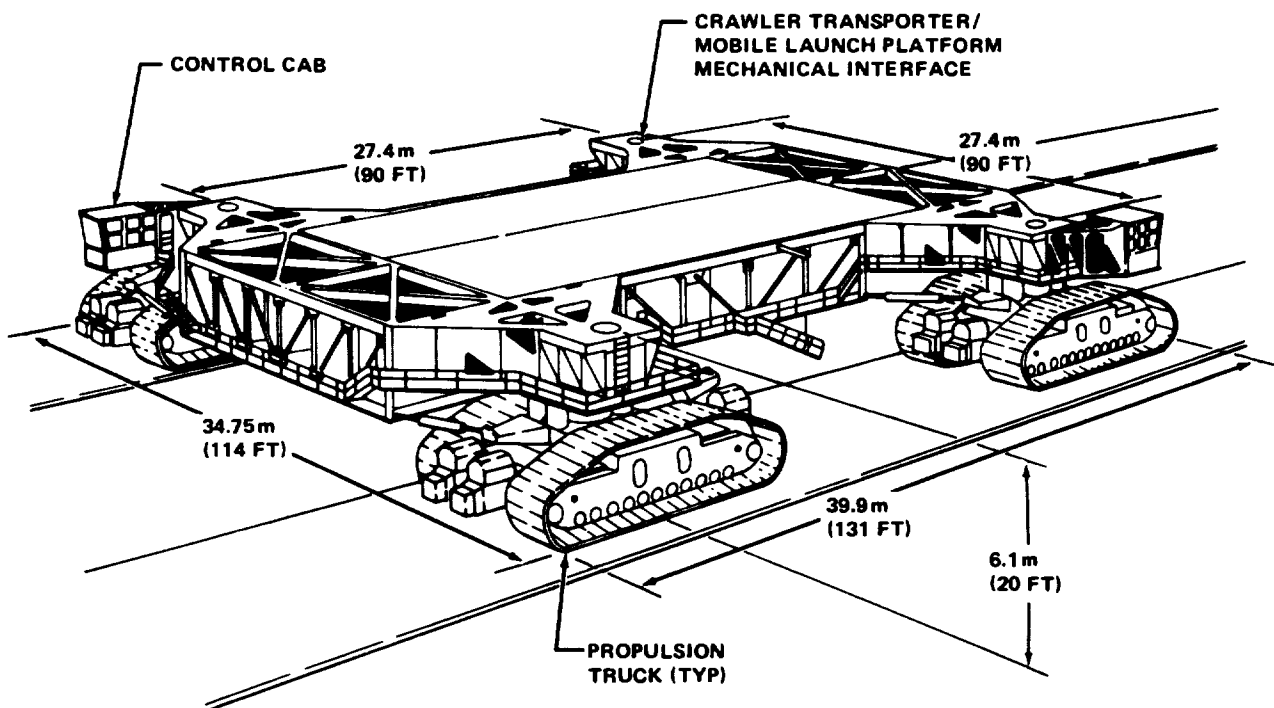

Figure 6-7.—Crawler-Transporter.

The transporters have a leveling system designed to keep the top of the space vehicle vertical within ± 10 minutes of arc—about the dimensions of a basketball. This system also provides the leveling operations required to negotiate the 5-percent ramp leading to the launch pads and to keep the load level when it is raised and lowered on pedestals at the pad and within the Vehicle Assembly Building.

The overall height of the transporter is 6.1 meters (20 feet) from ground level to the top deck on which the Mobile Launcher Platform is mated for transportation. The deck is flat and about the size of a baseball diamond—27.4 meters (90 feet) square.

Each transporter is powered by two 2050-kilowatt (2750-horsepower) diesel engines. The engines drive four 1000-kilowatt generators that provide electrical power to 16 traction motors. Through gears, the traction motors turn the four double-tracked crawlers spaced 27.4 meters (90 feet) apart at each corner of the transporter.

The Crawler-Transporters move on a roadway 40 meters (130 feet) wide, almost as broad as an eight-lane turnpike. The crawlerway consists of two 12.2-meter (40-foot) wide lanes separated by a 15.2-meter (50-foot) wide median strip and provides a traveling surface for the transporters between the VAB and Launch Pads A and B. The distance from the VAB to Pad A is 5.5 kilometers (3.4 miles). The distance to Pad B is 6.8 kilometers (4.2 miles). The roadway is built in three layers with an average depth of 2.1 meters (7 feet). The top surface on which the transporters operate is river gravel. The thickness of the gravel is 20.3 centimeters (8 inches) on curves and 10.2 centimeters (4 inches) on the straightaway sections.

LAUNCH PADS 39-A AND 39-B

The LC-39 launch pads are roughly octagonal in shape (fig. 6-8); each contains about 67 hectares (one-fourth square mile) of land. The pads are

elevated above the surrounding terrain: Pad A is 14.6 meters (48 feet) above sea level and Pad B is 16.8 meters (55 feet) above sea level. The hardstand area at the top of each pad measures 119 by 99 meters (390 by 325 feet).

Pad A construction was completed in mid-1978 and construction at Pad B is scheduled for completion in 1982. Major changes include construction of new hypergolic fuel and oxidizer support areas at the southwest and southeast corners, respectively, of the pad; removal of the RP-1 support area; erection of a new fixed service structure (FSS); addition of a rotating service structure (RSS); and replacement of the Saturn flame deflectors with three new flame deflectors. The upper portion of the umbilical tower removed from each Mobile Launcher Platform during modification has been installed at each pad to serve as a fixed service structure.

Access to the Space Shuttle on the pads (fig. 6-9) will be provided through the FSS vent arm for electrical power and for venting hydrogen from the External Tank; through the FSS Orbiter access arm for crew and passenger ingress; through the FSS External Tank gaseous oxygen vent arm for preventing icing on the External Tank and for venting oxygen vapors and nitrogen away from the vehicle; through the MLP tail service masts for propellant loading and electrical power; through the RSS mid-body umbilical unit for fuel-cell servicing and life-support functions; through the RSS facilities for loading and offloading payloads; and through the RSS hypergolic umbilical system for servicing the orbital maneuvering and reaction control systems with fluids and gases.

The major structures and facilities of the pads are described in the following sections.

Fixed Service Structure

The fixed service structure, located on the west side of the pad, is a square cross-section steel structure that provides access to the Shuttle Orbiter and to the rotating service structure. The FSS is essentially an open-framework structure 12.2 meters (40 feet) square and is permanently fixed to the pad surface. It incorporates several sections of the Saturn V umbilical towers removed from the Apollo mobile launchers in their conversion to Mobile Launcher Platforms. The FSS tower supports the hinge about which the rotary bridge supporting the RSS pivots as it moves between the Orbiter checkout position and the retracted position. A hammerhead crane situated atop the FSS provides hoisting services as required in pad operations. FSS work levels are at 6.1-meter (20-foot) intervals beginning at 8.2 meters (27 feet) above the surface of the pad. The height of the FSS from the pad surface to the top of the tower is 75.3 meters (247 feet). The height to the top of the hammerhead crane is 80.8

meters (265 feet), and the top of the lightning mast is 105.8 meters (347 feet) above the pad surface.

The FSS has three service arms: an access arm and two vent arms.

The Orbiter access arm (OAA) swings out to the Orbiter crew compartment hatch to provide personnel access to the forward compartments of the Orbiter. The outer end of the access arm ends in an environmental chamber that mates with the Orbiter and will hold six persons. The arm remains in the extended position until 2 minutes before launch to provide emergency egress for the crew. The Orbiter access arm is extended and retracted by two rotating actuators that rotate it through an arc of 70° in approximately 30 seconds. In its retracted position, the arm is latched to the FSS. The OAA is located 44.8 meters (147 feet) above the pad. It is 19.8 meters (65 feet) long, 1.5 meters (5 feet) wide, and 2.4 meters (8 feet) high and weighs 23 600 kilograms (52 000 pounds).

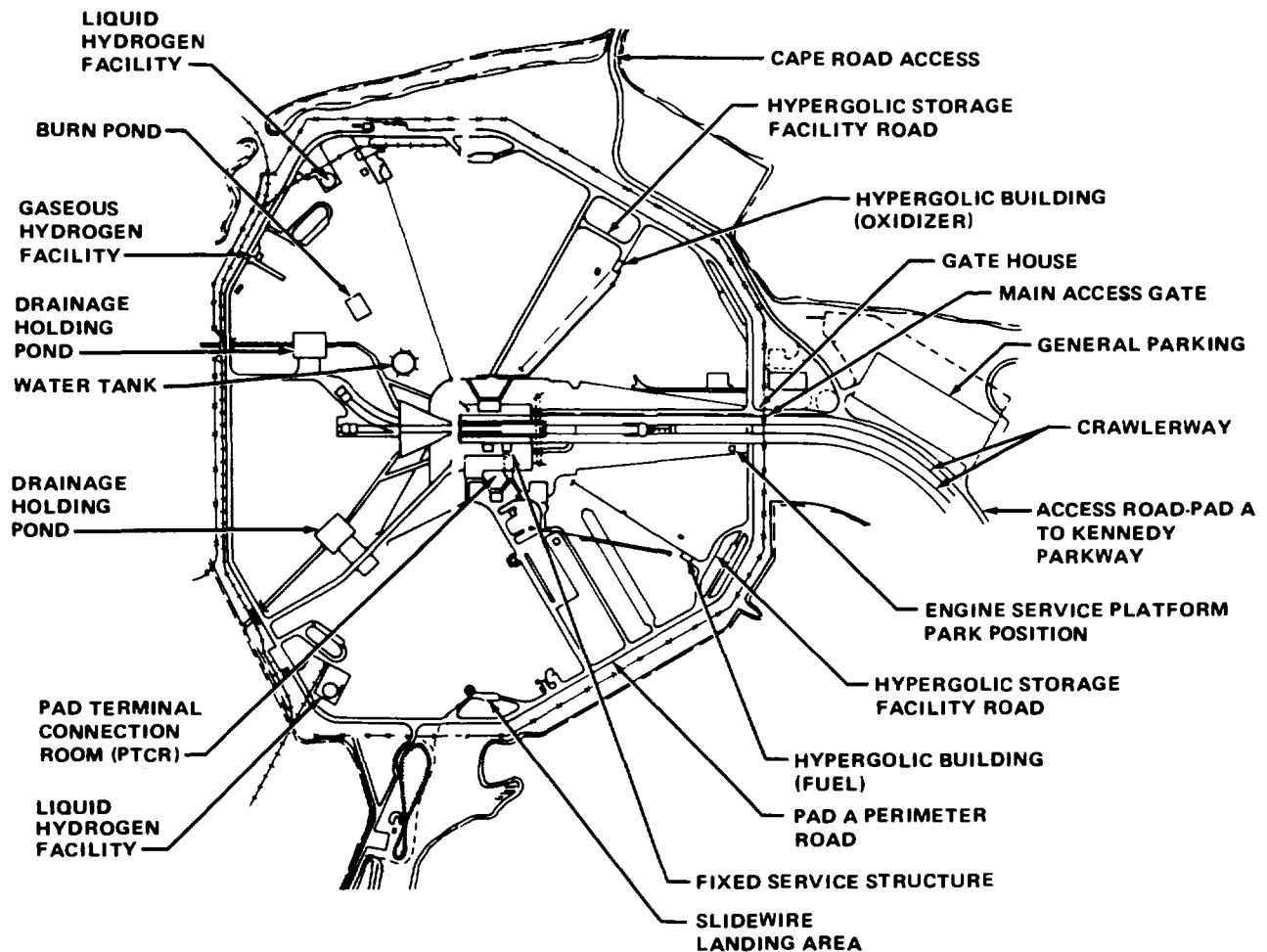

Figure 6-8.—Launch Pad 39-A surface arrangement.

The External Tank hydrogen vent line and access arm consists of a retractable access arm and a fixed supporting structure. This arm allows mating of the ET umbilicals and contingency access to the intertank interior while protecting sensitive components of the system from the launch environment.

The vent arm supports small helium and nitrogen lines and electrical cables, all mounted on a 20.3-centimeter (8-inch) inside-diameter hydrogen vent line. At SRB ignition, the umbilical is released from the Shuttle vehicle and retracted

84 centimeters (33 inches) into its latched position by a system of counterweights. The service lines rise approximately 46 centimeters (18 inches), pivot, and drop to a vertical position on the fixed structure where they are protected from the launch environment. All this activity occurs in approximately 4 seconds. The vent arm itself rotates through 210° of arc to its stowed position in about 3 minutes. The fixed structure is mounted on the northeast corner of the FSS 50.9 meters (167 feet) above the surface of the pad. The vent arm is 14.6 meters (48 feet) long and weighs 6800 kilograms (15 000 pounds).

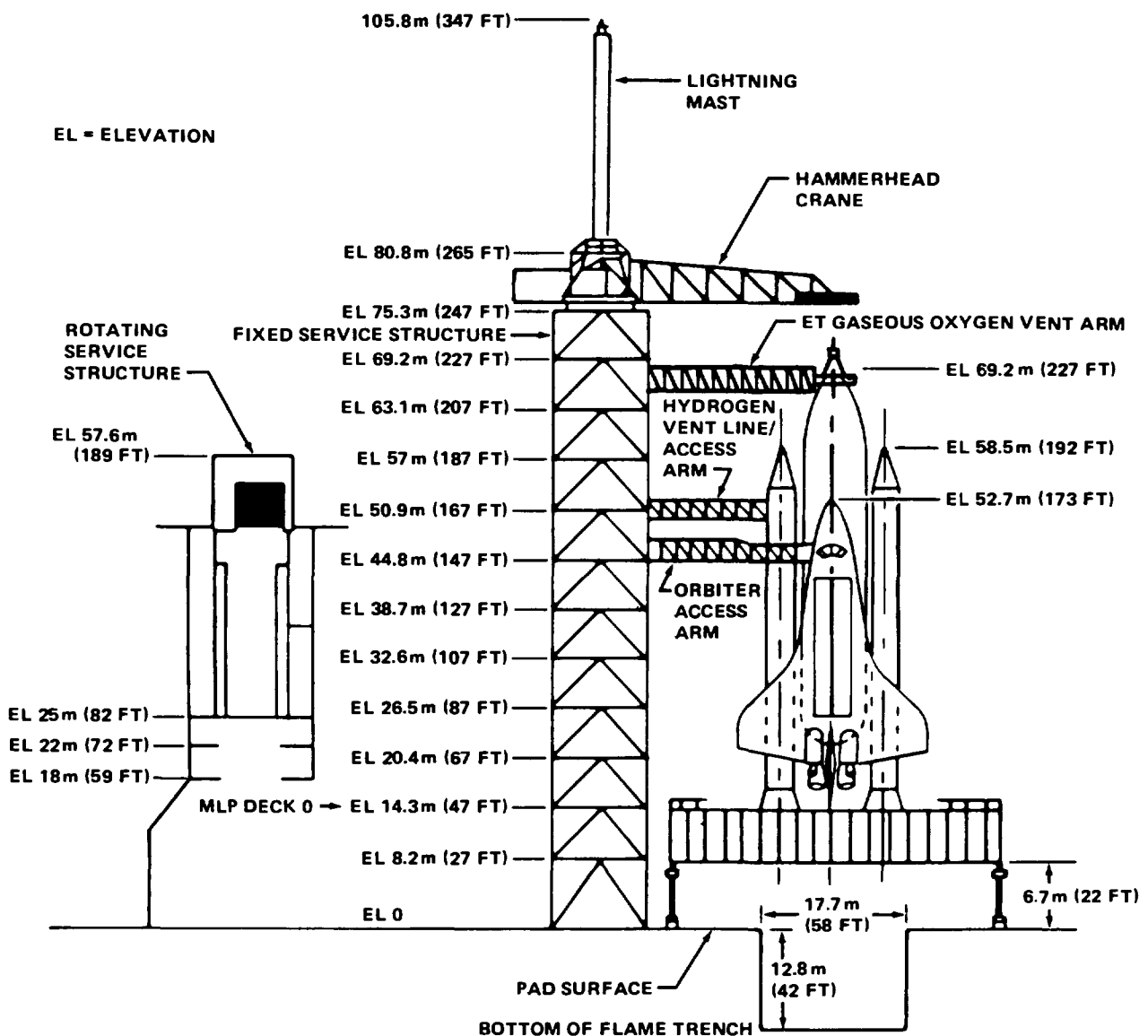

Figure 6-9.—Space Shuttle/pad elevations.

The External Tank gaseous oxygen vent arm is attached to the fixed service structure between the 69-meter (227-foot) and 63-meter (207-foot) levels. The arm suspends a hood or cap that will be lowered over the top of the External Tank and sealed by means of an inflatable collar. Heated gaseous nitrogen is introduced into the hood to warm the inflatable vent seals around the two gaseous oxygen louvers at the top of the External Tank. This prevents vapors from the liquid oxygen vent system at the top of the tank from condensing into ice, which could possibly become dislodged during lift-off and damage the Orbiter's thermal protection system tiles. The system also provides exhaust ducts to carry the oxygen vapors and the nitrogen away from the vehicle and serves as a rain shield for the top of the tank.

The vent system arm is 24.4 meters (80 feet) long, 2.4 meters (8 feet) high, and 1.5 meters (5 feet) wide. The diameter of the vent hood is 4 meters (13 feet). The weight of the arm and hood is 16 329 kilograms (36 000 pounds).

The vent system arm is extended at approximately T - 12 hours and the vent seals are inflated to an operating pressure of 3.4 to 6.9 kN/m² (0.5 to 1 psi) prior to cryogenic loading, which begins at approximately T - 5 hours. The vent system supports launch preparation until the ET vent valve closes at T - 2 minutes 55 seconds. Approximately 30 seconds later, the seals are deflated and the hood is retracted (retraction time approximately 30 seconds). After the hood has been stowed, the arm is retracted (retraction time approximately 1 minute). The arm will be in the retracted position at approximately T - 45 seconds and is held there hydraulically until T - 0, when it is latched to the FSS for lift-off.

The emergency exit system or slide wire (fig. 6-10) provides an escape route for personnel onboard the Shuttle and on the Orbiter access arm of the fixed service structure until ignition of the Solid Rocket Boosters. Five slide wires extend from the level of the Orbiter access arm to the ground on the west side of the pad. A single

stainless-steel basket enclosed with Nomex webbing 2.5 centimeters (1 inch) wide and 3 millimeters (one-eighth inch) thick is suspended by two trolleys from each wire (19 millimeters (0.75 inch) diameter) and positioned on the FSS for ready entry in the event of emergency. Each basket holds a maximum of two persons. When boarded, each basket slides down a 366-meter (1 200-foot) wire to the landing zone area west of the pad. The deceleration system is composed of a catch-net system and drag chains. The descent takes approximately 35 seconds. After the basket has been stopped by the deceleration system, those onboard may run or walk to the bunker area a short distance to the west.

The lightning mast extends above the fixed service structure and surrounding pad equipment and provides protection from lightning strokes. The 24.4-meter (80-foot) tall fiberglass mast is grounded by a cable that starts from a ground anchor 335 meters (1 100 feet) south of the FSS, angles up and over the lightning mast, then extends back down to a second ground anchor 335 meters (1 100 feet) north of the FSS. The mast functions as an electrical insulator holding the cable away from the FSS and as a mechanical support in rolling contact with the cable. The mast and its support structure extend 30.5 meters (100 feet) above the FSS.

Rotating Service Structure

The rotating service structure provides protected access to the Orbiter for changeout and servicing of payloads at the pad. The structure (fig. 6-11) is supported by a rotating bridge that pivots about a vertical axis on the west side of the pad's flame trench. The RSS rotates through 120° (one-third of a circle) on a radius of 49 meters (160 feet). The hinge column rests on the pad surface and is braced to the fixed service structure. Support for the outer end of the bridge is provided by two eight-wheel motor-driven trucks that move along circular twin rails installed flush with the pad surface. The track crosses the flame trench on a new permanent bridge.

The rotating service structure is 31 meters (102 feet) long, 15.24 meters (50 feet) wide, and 39.6 meters (130 feet) high. The elevation of the main structure above the surface of the pad extends from 18 to 57.6 meters (59 to 189 feet). The structure has Orbiter access platforms at five levels to provide access to the payload while the Orbiter is being serviced in the RSS. Each platform has independent extensible planks that can be arranged to conform to the individual payload configuration. With the exception of Spacelab and other horizontally handled cargoes, payloads may be loaded into the Orbiter from the RSS under environmentally clean or "white room" conditions.

Payloads will be transported to the rotating service structure in the payload canister. The

canister restrains and provides environmental protection for the various Shuttle payloads while in transit. It also provides the constant payload envelope required by payload handling devices and environmental services to the payload itself. The payload canister is 21 meters (69 feet) long, 6.4 meters (21 feet) wide, and 6.4 meters (21 feet) high. It weighs 38 555 kilograms (85 000 pounds). The canister can accommodate payloads up to 18.3 meters (60 feet) long, 4.6 meters (15 feet) in diameter, and 29 500 kilograms (65 000 pounds) in weight.

Other rotating service structure elements servicing the space vehicle are the Orbiter midbody umbilical unit, the hypergolic umbilical system, and the orbital maneuvering system (OMS) pods heated-gas purge system.

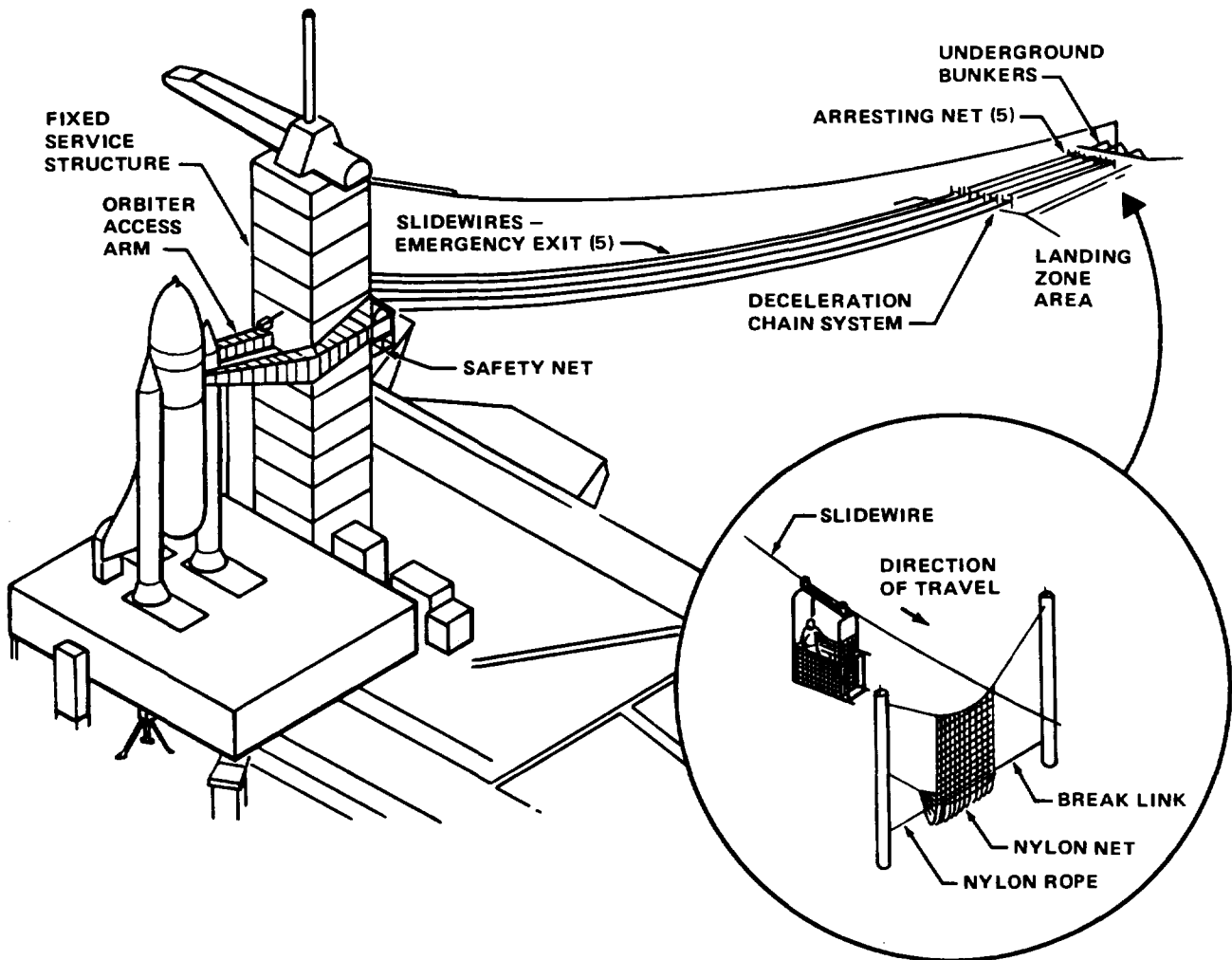

Figure 6-10.—Emergency exit system.

The Orbiter midbody umbilical unit provides access and services to the mid-fuselage portion of the Orbiter on the pad. Liquid oxygen and liquid hydrogen for the fuel cells and gases such as nitrogen and helium are provided through the umbilical unit. The unit is 6.7 meters (22 feet) long, 4 meters (13 feet) wide, and 6 meters (20 feet) high. The Orbiter midbody umbilical unit extends from the rotating service structure at levels ranging from 48.2 to 53.6 meters (158 to 176 feet) above the surface of the pad.

The hypergolic umbilical system carries hypergolic fuel and oxidizer, helium, and nitrogen service lines from the fixed service structure to the vehicle. Six umbilical handling units — manually operated and locally controlled — are structurally attached to the rotating service structure.

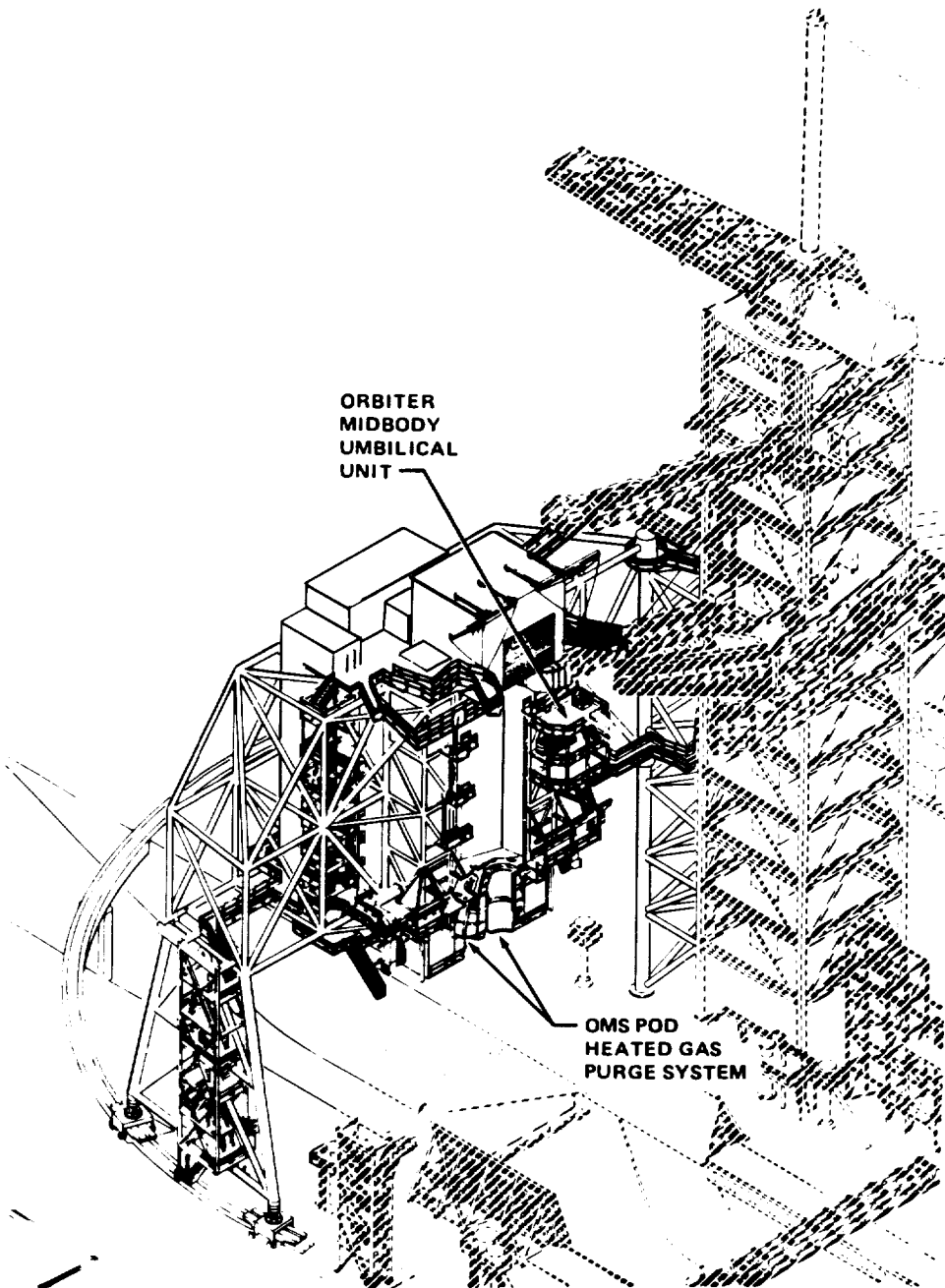

Figure 6-11.—Rotating service structure.

The Orbiter midbody umbilical unit, hypergolic umbilical system, and OMS pod heated-gas purge system connections with the Orbiter are severed when the rotating service structure is prepared for retraction to its park site at approximately the T - 6-hour point in the countdown.

The OMS pods heated-gas purge system is suspended from the lower portion of the rotating service structure and consists of heated purge covers designed to enclose the OMS pods located on the aft upper portion of the Orbiter. The Orbiter's OMS pods have structural skins consisting of layered graphite/epoxy covered by thermal protection system silica tiles and Nomex felt reusable surface insulation attached by an adhesive. The graphite/epoxy absorbs moisture from the atmosphere, resulting in a degradation of strength under reentry conditions. The heated-gas purge system is designed to reduce the moisture level in the OMS pods to that considered desirable for flight. The OMS pods heated-gas purge covers are concave in shape to fit the contours of the pods and have an average height of 4.9 meters (16 feet) with 1.8-meter (6-foot) extensions to cover the reaction control system (RCS) clusters on the aft outboard portions of each pod. The purge covers, fabricated of an aluminum framework covered with an aluminum skin, are located between the 18- and 25-meter (59- and 82-foot) levels of the rotating service structure. A pressurized herculite seal between the OMS pods and the covers excludes ambient air. Conditioned air (dried air with a relative humidity of 1 to 2 percent) is heated in the pad terminal connection room beneath the pad and flows in pipes attached to the fixed service structure and the rotating service structure before entering the pod covers near their tops. The air flows over the pod structures under a pressure of approximately 3.4 kN/m² (0.5 psi). The air leaves the pod covers through vents at the bottom. The temperature of the heated air will be maintained at up to 380 K (107° C or 225° F) for extended periods before the loading of the hypergolic propellants for the OMS and RCS systems. After propellant loading, the purge will be maintained at a temperature of approximately 310 K (38° C or 100° F) for various periods of time until the final countdown begins.

Flame Deflector System

Pad structures are insulated from the intense heat of launch by the flame deflector system, which protects the flame trench floor and the pad surface along the top of the flame trench. The flame trench transects the pad's mound at ground level and is 149.4 meters (490 feet) long, 17.7 meters (58 feet) wide, and 12.2 meters (40 feet) high.

The Orbiter flame deflector is fixed and is 11.6 meters (38 feet) high, 22 meters (72 feet) long, and 17.6 meters (57.6 feet) wide. The top of the SRB flame deflector abuts with that of the Orbiter flame deflector to form a flattened, inverted V-shaped structure beneath the three MLP exhaust holes. The SRB deflector is 13 meters (42.5 feet) high, 12.8 meters (42 feet) long, and 17.4 meters (57 feet) wide. The deflectors are built of steel and covered with an ablative, or heat shedding, surface with an average thickness of 12.7 centimeters (5 inches). There are two movable SRB side flame deflectors, one located on each side of the flame trench. They are 6 meters (19.5 feet) high, 13.4 meters (44 feet) long, and 5.3 meters (17.5 feet) wide.

Sound-Suppression Water System

The Shuttle Orbiter with its delicate payloads is much closer to the MLP surface than was the Apollo spacecraft at the top of a Saturn V/IB. A sound-suppression water system has been installed on the pads to protect the Orbiter and its payloads from damage by acoustical energy reflected from the Mobile Launcher Platform during launch.

The system includes an elevated water tank with a capacity of 1 135 500 liters (300 000 gallons). The tank is 88.4 meters (290 feet) high and stands on the northeast side of the pad. The water will be released just before ignition of the three Space Shuttle Main Engines and twin Solid Rocket Boosters and will flow through parallel 2.1-meter (7-foot) diameter pipes to the pad area.

Water will be pouring from 16 nozzles atop the flame deflectors and from outlets in the SSME exhaust hole in the Mobile Launcher Platform at SSME ignition at T - 3.46 seconds. When SRB ignition and lift-off follow at T + 3 seconds, a torrent of water will begin flowing onto the platform from six large quench nozzles or "rainbirds" mounted on its surface. The peak flow from the pre- and post-lift-off systems will be at the rate of 3 406 500 liters/min (900 000 gal/min) 9 seconds after lift-off. The MLP "rainbirds" are 3.7 meters (12 feet) high. The two in the center are 107 centimeters (42 inches) in diameter; the other four have a diameter of 76 centimeters (30 inches).

Acoustical levels reach their peak when the Space Shuttle is approximately 91 meters (300 feet) above the platform and should no longer be a problem when an altitude of 305 meters (1000 feet) is reached. Below the peak level, the rocket exhaust is channeled over the flame deflectors and into the flame trench; above the peak level, sound is reflected off the metal plates of the MLP surface. In terms of time, the maximum sound reflection comes approximately 5 seconds after lift-off. The problem ends after the Shuttle has been airborne for about 10 seconds and has reached an altitude of 305 meters (1000 feet).

Design specifications for Shuttle payloads require the capability to withstand acoustical loads of up to 145 decibels. It is anticipated that the sound-suppression system will reduce the acoustical levels within the Orbiter payload bay to about 142 decibels, 3 decibels below the design requirement. The decibel level on the aft heat shield of the Orbiter without water suppression would be approximately 167 or 168; the sound-suppression system is expected to lower the level to 162 or 163. For comparison, the decibel reading at the base of the Saturn V at lift-off averaged 160.

Liquid Oxygen System

The liquid oxygen (LO₂ or lox) used as an oxidizer by the Orbiter's main engines is stored in a 3 406 500-liter (900 000-gallon) storage tank

located at the northwest corner of the pad. This ball-shaped vessel is a huge vacuum, or Dewar, bottle designed to store cryogenic (supercold) lox at a temperature lower than 90 K (-183° C or -297° F). Lox is quite heavy—3.8 liters (1 gallon) weighs approximately 4.5 kilograms (10 pounds)—and is transferred to the pad by two main pumps rated at 37 850 liters/min (10 000 gal/min) each.

Liquid Hydrogen System

The liquid hydrogen (LH₂) used as a fuel by the Orbiter's main engines is stored in a 3 200 000-liter (850 000-gallon) storage tank located at the northeast corner of the pad. This large ball-shaped vessel is also a huge vacuum bottle designed to contain and store liquid hydrogen, a cryogenic fluid much colder than lox. Liquid hydrogen vaporizes at temperatures above 20 K (-253° C or -423° F). It is extremely light—3.8 liters (1 gallon) weighs approximately 0.23 kilogram (0.5 pound). Because of its lightness, pumps are not needed for transfer to the pad. Liquid hydrogen vaporizers convert a small portion of the liquid hydrogen stored in the tank into a gas and this gas pressure exerted from the top of the tank moves the liquid hydrogen into the transfer lines and to the pad.

Vacuum-jacketed transfer lines carry these supercold fluids to the Mobile Launcher Platform where they are fed into the Orbiter through the tail service masts.

The Orbiter's orbital maneuvering system and reaction control system engines use monomethyl hydrazine (MMH) as a fuel and nitrogen tetroxide (N₂O₄) as an oxidizer. These fluids can be stored at ambient temperatures and are hypergolic; that is, they ignite on contact. They are stored in well-separated areas on the southwest (MMH) and southeast (N₂O₄) corners of the pads. These propellants are fed by transfer lines to the pad and through the fixed service structure to the rotating service structure hypergolic umbilical system. Other fluids and gases supplied on the pad include helium, nitrogen, shop air, Freon 21, and ammonia.

LAUNCH PAD/LAUNCH PROCESSING INTERFACE

The vital links between the launch processing system in the Launch Control Center and the ground support equipment and flight hardware on the pad are provided by elements located in the pad connection terminal room (PCTR) below the pad's elevated hardstand. All pad LPS terminals (hardware interface modules) interface with the central data subsystem in the Launch Control Center.

HYPERGOL MAINTENANCE AND CHECKOUT FACILITY

The Hypergol Maintenance and Checkout Facility (HMF) provides all facilities required to process and store the hypergol-fueled modules that make up the Orbiter's forward reaction control system (FRCS), orbital maneuvering system (OMS), auxiliary propulsion system (APS), and certain payload bay kits. The facility occupies a group of buildings in an isolated section of the KSC Industrial Area approximately 13 kilometers (8 miles) southeast of the Vehicle Assembly Building. Originally built for the Apollo Program, these buildings have been extensively modified to support Space Shuttle operations.

LAUNCH EQUIPMENT TEST FACILITY

The Launch Equipment Test Facility (LETf) is located in the KSC Industrial Area immediately south of the Operations and Checkout Building. This facility is required to test the operation of launch-critical systems or ground systems that could cause failures in the space vehicle if they did not function properly. The facility is able to simulate such launch vehicle events as movement due to the wind, Orbiter engine ignition and lift-off, and the effects of solar heating and cryogenic shrinkage. The ability of the ground systems to react properly to these events must be verified before committing the ground support equipment to a manned launch.

The systems tested are the ET vent line, the Orbiter access arm, and the ET gaseous oxygen vent arm, all on the fixed service structure, and the tail service masts and the SRB holddown posts on the Mobile Launcher Platform. The test systems include an SRB holddown test stand, a

tower simulator, an Orbiter access arm random-motion simulator, and a tail service mast/ET hydrogen vent line random-motion and lift-off simulator. Tests are monitored in a control building on the west side of the LETf complex.

The test equipment is not new. Previously located at the NASA Marshall Space Flight Center in Huntsville, Alabama, the equipment was used for similar purposes in the Apollo Program. It was transported to KSC by barge and the simulators were refurbished and modified for the Space Shuttle Program.

PAYLOAD PROCESSING FACILITIES AND SUPPORT EQUIPMENT

Space Shuttle payloads will be processed in a number of facilities at KSC and at the Cape Canaveral Air Force Station. These facilities have been used over the years for Apollo, Skylab, and a wide variety of unmanned spacecraft launched by expendable vehicles. Where necessary, they have been modified for the Shuttle Program.

The Space Shuttle is planned as an economical single-configuration reusable Space Transportation System, and payload processing has been streamlined, standardized, and systemized for maximum efficiency. To shorten turnaround time, it is imperative that the payloads be processed expeditiously and be ready for launch simultaneously with the Shuttle vehicle. In addition, funding limitations have demanded that expensive manpower be conserved by a simplified checkout system.

Payloads will be installed in the Orbiter either horizontally in the Orbiter Processing Facility or vertically at the pad (fig. 6-12). To obtain the shortest possible Shuttle turnaround time, KSC will perform a simulated Orbiter-to-cargo-interface verification of the entire cargo before its installation in the Orbiter. Payloads to be installed horizontally in the Orbiter Processing Facility will be verified in the Operations and Checkout Building. Payloads to be installed vertically at the pad will be verified at the Vertical Processing Facility (VPF). Payloads installed vertically consist primarily of automated spacecraft involving upper stages and operations too hazardous to be performed in the Orbiter Processing Facility.

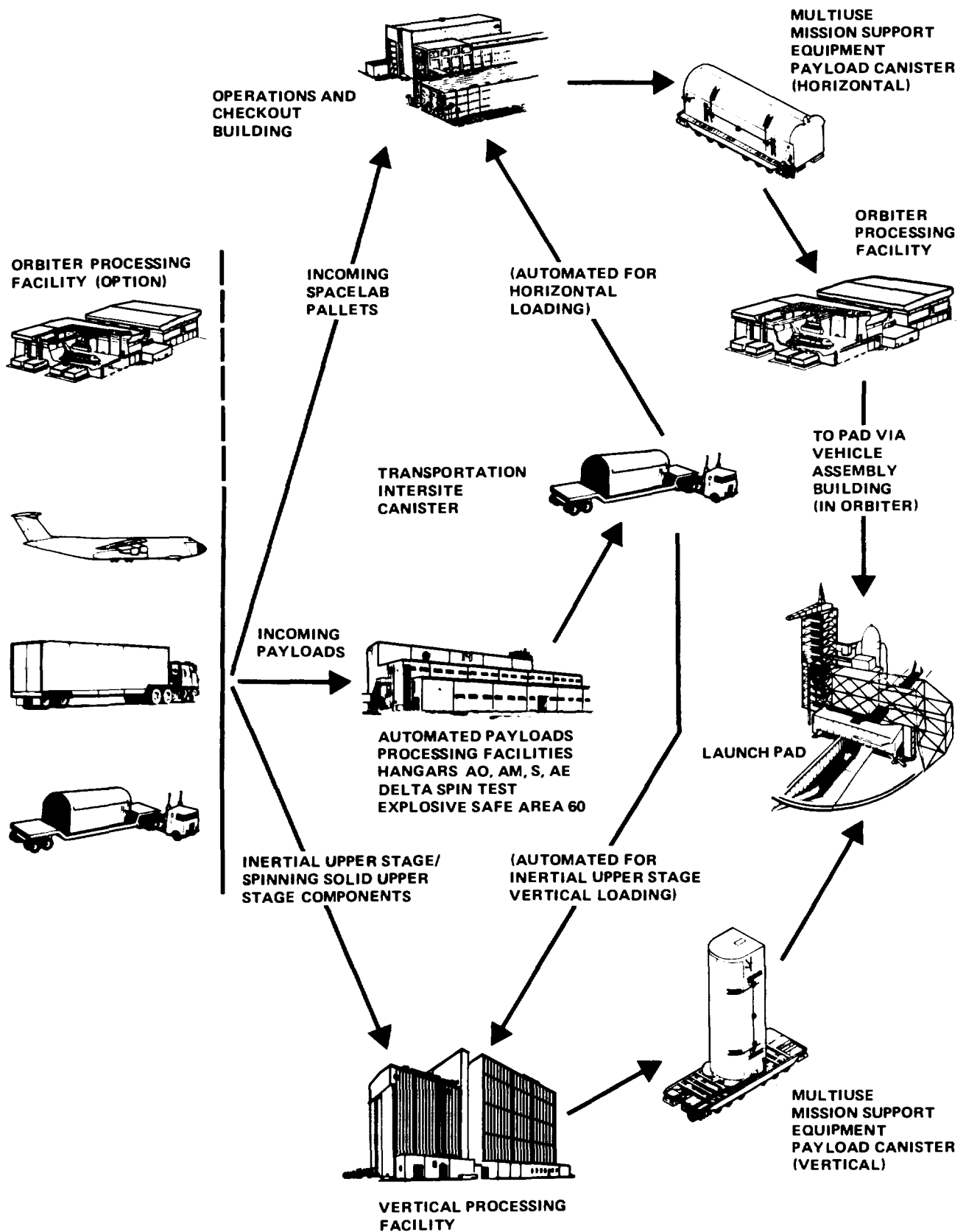

Figure 6-12.—Space Transportation System payload operations.

Essential to the processing of payloads at various KSC Shuttle facilities are the multiuse mission support equipment (MMSE): the payload canister (described previously), the payload canister transporter, and the payload strongback.

Payload Canister Transporter

The payload canister transporter (fig. 6-13) is a 48-wheel self-propelled truck designed to operate between and within Shuttle payload processing facilities. It will be used to transport the payload canister and its associated hardware throughout KSC.

The transporter is 19.8 meters (65 feet) long and 7 meters (23 feet) wide. Its elevating flatbed has a height of 1.8 meters (6 feet) but can be lowered to 1.6 meters (5 feet 3 inches) or raised to 2.1

meters (7 feet) \pm 7.6 centimeters (3 inches). Its wheels are independently steerable and permit the transporter to move forward, backward, or sideways; to "crab" diagonally; or to turn on its own axis like a carousel. It has self-contained braking and stabilization jacking systems.

The transporter is driven by a hydraulic system powered by a liquid-cooled diesel engine between facilities and by an electric motor using ground power inside the facilities.

The bare transporter weighs 63 500 kilograms (140 000 pounds). With a full load of diesel fuel and with the environmental control system, fluid and gas services, electrical power system, and instrumentation and communication system modules mounted on it, the transporter has a gross weight of 77 300 kilograms (170 500 pounds).

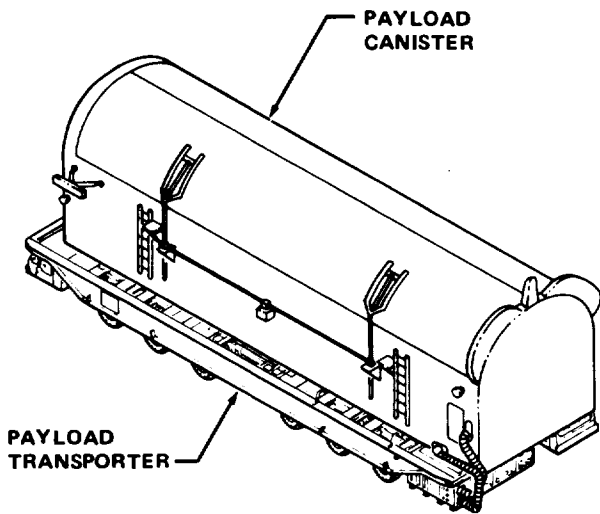

HORIZONTAL TRANSPORTATION MODE

Figure 6-13.—Payload canister transporter.

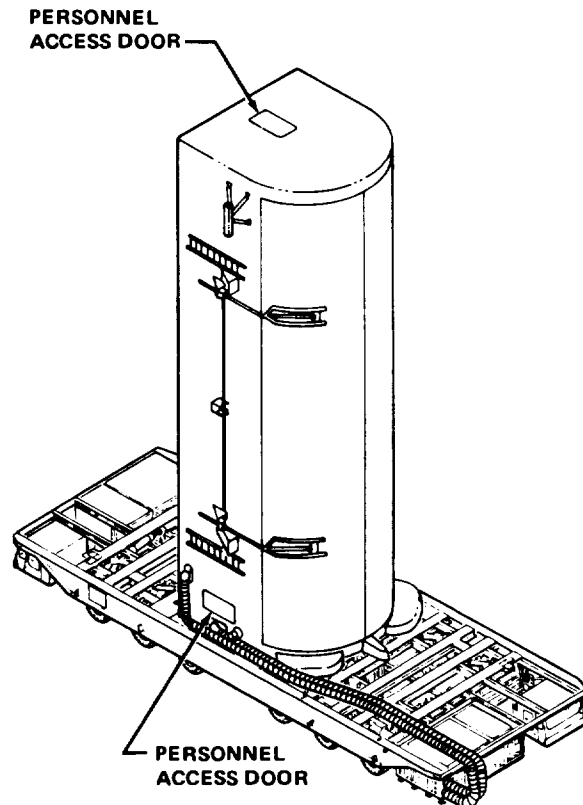

VERTICAL TRANSPORTATION MODE

The transporter is steerable from diagonally opposed operator cabs on each end. Its top speed unloaded is 16 km/h (10 mph). The maximum speed of the fully loaded transporter is 8 km/h (5 mph). Because payload handling will require precise movements, the transporter has a "creep mode" that permits it to move as slowly as 0.64 cm/s (0.25 in/s) or 0.023 km/h (0.014 mph). Interfacility drive power is provided by a 298-kilowatt (400-horsepower) diesel engine. Intrafacility drive power comes from an 82-kilowatt (110-horsepower) electric motor. The transporter will carry the payload canister in either the horizontal or vertical position.

Payload Strongback

The payload strongback (fig. 6-14) provides support for all payload sections during horizontal handling. A major use for the strongback is the handling of Spacelab but it will also be used to

unload a wide variety of payloads during postflight handling in the Orbiter Processing Facility. Movable attachment points permit the strongback to be used for different payloads.

The strongback consists of a rigid steel frame with adjustable beams, brackets, and clamps. It will not induce any bending or twisting loads on payload elements. The strongback is 18.3 meters (60 feet) long, 4.9 meters (16 feet) wide, and 2.7 meters (9 feet) high and weighs 18 150 kilograms (40 000 pounds).

Horizontal Cargo Processing

Horizontally integrated payloads are received, assembled, and integrated into a cargo in the Operations and Checkout Building before being mated with the Orbiter at the Orbiter Processing Facility. The Spacelab and its payloads constitute the majority of horizontal payloads.

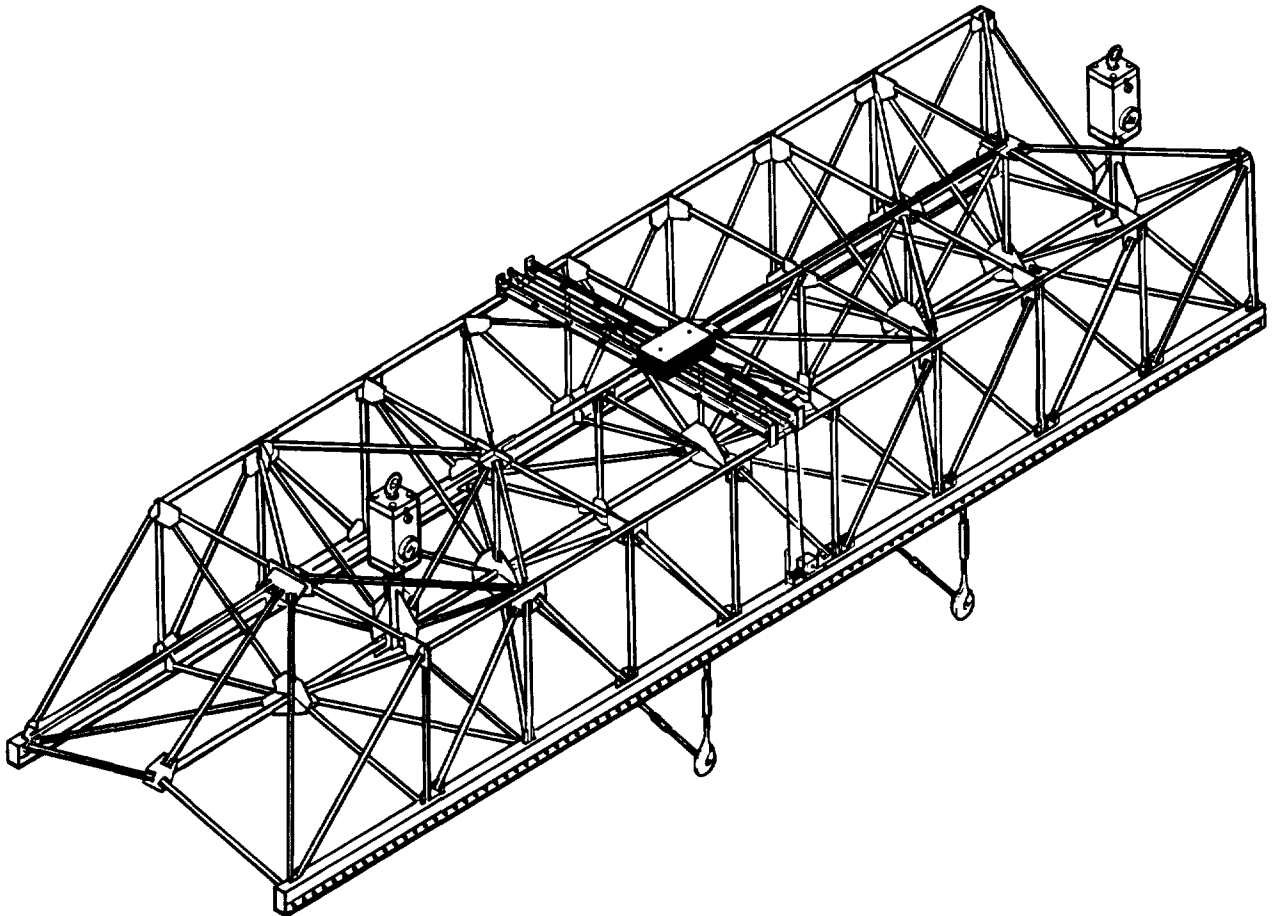

Figure 6-14.—Payload strongback.

OPERATIONS AND CHECKOUT BUILDING

The Operations and Checkout (O&C) Building is a five-story structure containing 55 740 square meters (600 000 square feet) of offices, laboratories, astronaut quarters, and cargo assembly areas. It is located in the Industrial Area immediately east of the KSC Headquarters Building.

Spacelab Assembly and Test Area

The Spacelab assembly and test area in the Operations and Checkout Building was used for the assembly and testing of Apollo spacecraft during the Apollo Program and has received the necessary modifications to adapt it to the Space Shuttle era. The Spacelab assembly and test area is 198 meters (650 feet) long and a uniform 26 meters (85 feet) wide. It is divided into a high-bay area 53 meters (175 feet) long and 32 meters (104 feet) high and a low-bay area 145 meters (475 feet) long and 21 meters (70 feet) high. The assembly and test area is environmentally controlled to 297 K (24° C or 75° F) \pm 2°. Relative humidity is maintained below 60 percent.

The major Spacelab facilities within the O&C Building are two integrated assembly and checkout workstands, an engineering-model workstand, pallet staging workstands, a rack/floor workstand, a tunnel maintenance area, and two end cone stands.

The two integrated workstands will be controlled from two automatic test equipment (ATE) control rooms located on the third floor of the O&C Building. The capability exists to switch control of either workstand to either control room. Mechanical and electrical ground support equipment required to support Spacelab assembly and testing are located in and around the workstands. These facilities make it possible to support two independent Spacelab processing flows.

To assist in Spacelab/Orbiter interface verification, an Orbiter interface adapter and two racks that simulate the Orbiter's aft flight deck are provided at the end of the workstand. Orbiter utility interfaces — electrical, gas, and fluid — will be provided by ground support equipment cables or lines.

Spacelab Processing

The Spacelab ground-operations concept permits a user to design and develop an experiment that can be integrated with other individual experiments into a complete Spacelab payload. NASA will provide racks and pallet segments to STS users and integration and verification will be possible with minimum Spacelab-unique ground support equipment.

The processing of Spacelab payloads will begin with the integration and checkout of experimental equipment with individual-experiment mounting elements—racks for the Spacelab pressurized module and pallet segments for the experiments to be exposed to the space environment. Experiments sponsored by the European Space Agency will undergo preliminary integration in Europe before shipment to the United States.

Payload elements will be delivered to the launch site in as near flight-ready condition as is practical. After initial integration is complete, the STS user will be responsible for providing transportation of the payload to the launch site.

After delivery of individual experiments and payloads to the Operations and Checkout Building, the Spacelab "train" of pallets and racks will be assembled using the pallet and/or rack stands. All work that can be accomplished before processing on the Spacelab integration workstand will be done during this period. Following mechanical buildup of the payload train, the Spacelab elements will be transferred to the Spacelab integration workstand for integration with the Spacelab module/igloo.

Spacelab operational hardware will have been undergoing refurbishment and buildup in parallel with the payload buildup. After buildup of the total Spacelab and payload configuration in the workstand, the module aft and cone will be installed, pallets will be positioned, and utilities between the pallets and module will be connected. Upon completion of checkout and test activities, the Spacelab will be hoisted by bridge cranes and the strongback, installed in the payload canister, and moved to the Orbiter Processing Facility by the canister transporter. Environmental conditioning, through an air purge and system monitoring, are provided during transport to the OPF.

PAYLOAD INSTALLATION IN ORBITER PROCESSING FACILITY

Payload removal from the canister and installation in the Orbiter will be accomplished in the Orbiter Processing Facility. The cargo to be installed will be hoisted in a horizontal attitude from its canister/transporter, positioned over the Orbiter, lowered into the payload bay, and secured in place. The strongback and facility crane will support this operation.

After payload installation, the Shuttle payload interfaces will be connected and verified. An integrated test will be conducted to complete the verification of interfaces between the payloads and the Orbiter.

Upon completion of testing, the payload bay doors will be closed and latched. The payload bay environment with the doors closed will be maintained by providing a purge of clean air at 294 K (21° C or 70° F) and a maximum relative humidity of 50 percent. At this point, the Orbiter will be powered down for movement to the Vehicle Assembly Building. No power or purge is provided from this point until completion of the Shuttle vehicle assembly in the VAB.

ORBITER OPERATIONS FROM OPF TO LAUNCH PAD

Upon completion of operations in the Orbiter Processing Facility, the Orbiter will be towed to the Vehicle Assembly Building for transition from the horizontal to the vertical position. The Orbiter's cargo is quiescent during VAB operations with no routine access planned. Shuttle power will be available after the MLP and ET interfaces have been connected and verified.

Following the completion of mating and Shuttle system interface verification checks with the Mobile Launcher Platform, the Space Shuttle vehicle will be rolled out on the Crawler-Transporter to the pad. The Orbiter will be powered down during the movement to the pad and power will not be available to a payload during this time unless it is provided by a self-contained source.

LAUNCH PAD SERVICING

After the Mobile Launcher Platform has been mated hard down on its mounts at the pad and the umbilicals are connected, an interface verification test will be conducted to verify the integrity and serviceability of the pad/Shuttle system interfaces. Access to payloads at the pad is not planned, although the capability exists from the rotating service structure to open the payload bay doors and reach the payload from the extendable platforms of the payload ground handling mechanism.

VERTICALLY INTEGRATED PAYLOADS

Vertically integrated payloads are normally received in payload processing facilities in Buildings AE, AO, AM and Hangar S at the Cape Canaveral Air Force Station or in Spacecraft Assembly and Encapsulation Facility-2 (SAEF-2) in the KSC Industrial Area. These payloads consist primarily of automated free-flying satellites or spacecraft using upper stages and their processing normally involves some hazardous operations, which are conducted in explosive safe areas located at the Cape Canaveral Air Force Station. Vertical integration into a complete Shuttle cargo is done in the Vertical Processing Facility (VPF). The VPF high-bay area has a ceiling height of 32 meters (105 feet) and a usable floor area of 943 square meters (10 153 square feet).

Spacecraft undergo buildup in the clean room environments of the payload processing facility to which they are assigned and where they receive preintegration testing. After functional tests are completed, the spacecraft are moved to an explosive safe area where hazardous operations will be conducted if required. These areas are the Delta Spin Test Facility and Explosive Safe Area 60, both located at the Cape Canaveral Air Force Station. Activities performed in these areas include installation of solid propellant apogee motors or ordnance separation devices, hydrazine loading, or any other work involving items that are potentially explosive or hazardous. Upon completion of all hazardous operations, the spacecraft is ready for movement to the Vertical Processing Facility.

Shuttle upper stages include the spinning solid upper stage A (SSUS-A), the spinning solid upper stage D (SSUS-D), and the inertial upper stage (IUS). The SSUS-A and SSUS-D are received at the Delta Spin Test Facility where they undergo inspection, assembly, and test. Spacecraft that are scheduled to fly on an SSUS-D are mated with the SSUS-D in the Delta Spin Test Facility and then moved into the Vertical Processing Facility. Spacecraft scheduled to fly on an SSUS-A are mated with the SSUS-A in the Vertical Processing Facility.

The IUS is received at the Solid Motor Assembly Building in the Titan III Complex at the Cape Canaveral Air Force Station. Operations in the Solid Motor Assembly Building are under the management of the U.S. Air Force. When these operations are complete, the IUS is moved to the Vertical Processing Facility at KSC for mating with its spacecraft. Installation in the Vertical Processing Facility and all subsequent operations are conducted under KSC management.

The final integration and testing of vertically integrated payloads is accomplished in the Vertical Processing Facility. Operations in the VPF are conducted under environmentally controlled conditions. The entire VPF environment is temperature controlled at 297 K (24° C or 75° F) \pm 3°; relative humidity is controlled at 45 \pm 5 percent.

Spacecraft processing within the VPF will vary depending on the type of upper stage involved. A spacecraft already mated with an SSUS-D is installed directly into one of two workstands after removal from the transporter/container. Spacecraft using an SSUS-A or an IUS upper stage will be mated with the upper stage previously positioned in a workstand in the VPF high bay. Regardless of where the upper stages are mated to their spacecraft, the entire Shuttle cargo will eventually be assembled in a single VPF workstand. Testing of individual payloads (spacecraft mated with an upper stage) will be accomplished before any combined cargo testing or simulated Orbiter to cargo testing.

A major test conducted in the Vertical Processing Facility is the cargo integration test. Cargo integration test equipment (CITE) in the VPF permits—by simulation—the verification of payload/cargo mechanical and functional

connections with the Orbiter before they are shipped from the VPF to the launch pad. Similar equipment in the Operations and Checkout Building performs the same functions for payloads that are integrated into the Orbiter horizontally.

After completion of testing, the entire Shuttle cargo is inserted into the payload canister by the vertical payload handling device. Environmental conditioning and system monitoring are provided during transport to the pad for insertion in the rotating service structure.

Upon arrival at the rotating service structure, the payload is installed as described previously. Installation of the payload into the rotating service structure occurs before transfer of the Space Shuttle vehicle to the launch pad.

PAYLOAD PROCESSING VARIATIONS

There are many variations from the standard flow of horizontally and vertically integrated payloads at KSC. Among the specific flow variations are small self-contained payloads, life-sciences payloads, and Department of Defense payloads.

Small self-contained or “get away special” payloads will be received and built up in the Operations and Checkout Building and installed in the Orbiter in the Orbiter Processing Facility. Because they have limited Orbiter interfaces, most small self-contained payloads will not require interface verification in the cargo test integration facility and will be built up, attached to a special bridge beam, and installed in the Orbiter much like any other bridge beam.

The flight hardware associated with life-sciences payloads will normally follow the flow for horizontally integrated payloads. However, live specimens for these payloads will be received at Hangar L at the Cape Canaveral Air Force Station. Technical activities in Hangar L are managed by NASA's Ames Research Center; KSC will have operations and maintenance responsibility. Life-sciences specimens, or live specimens already in their flight containers, are installed at the launch pad by opening the payload bay doors and installing the specimens from a special access platform mounted on the payload ground handling mechanism or through the crew entry hatch with the live specimens in their containers mounted in the Orbiter mid-deck area of the crew cabin.

Department of Defense (DOD) payloads or cargo elements will be shipped from their factory locations by air to the Cape Canaveral Air Force Station. Upon arrival, they will be moved to the Solid Motor Assembly Building for assembly and prelaunch testing. The DOD cargo will then be transported in the payload canister to the launch pad, where it will be installed in the rotating service structure for insertion into the Orbiter's payload bay.

MISCELLANEOUS FACILITIES AND EQUIPMENT

Mate/Demate Stiffleg Derrick

The mate/demate stiffleg derrick (MDSD) was developed to meet the single mate/demate cycle of Orbiter 101 and its 747 carrier aircraft required for Space Shuttle vibration tests at the Marshall Space Flight Center (MSFC). The derrick is portable and also provides the means to recover a Space Shuttle Orbiter compelled to land at any one of a number of contingency landing sites around the world.

The derrick may be used to hoist, position, secure, and lower the Orbiter for all Orbiter/747 mate or demate operations. The system consists of a stiffleg derrick with a 91-metric-ton (100-ton) capacity, a 91-metric-ton (100-ton) capacity mobile crane, a wind restraint system, a communications system, and support accessories.

The mate/demate stiffleg derrick offered the least expensive way of performing the one-time mate/demate cycle at the Marshall Space Flight Center (fig. 6-15). The stiffleg derrick was removed from a Marshall test stand, refurbished, and modified. It is mounted on a 7.6-meter (25-foot) high triangular steel tower to clear the 747's port wing and permit the boom to reach the Orbiter's aft hoist points. The derrick includes three major subsystems: hoisting, wind restraint, and communications.

1. Hoisting — The stiffleg derrick will hoist the aft end of the Orbiter and the mobile crane will hoist the forward end.

2. Wind restraint — Six plastic-coated steel tagline masts, four nylon taglines, and two trucks provide wind restraint of the Orbiter while it is suspended awaiting further hoisting/lowering operations.

3. Communications — Radio communications, in the form of Handie-Talkies with headsets, are used to coordinate the activities of the mate/demate team.

The derrick will be stored at KSC should it be needed at some future date to recover an Orbiter from a contingency landing site. The mobile crane portion of the system would be leased if or when needed.

Towing Tractor

The towing tractors at the Kennedy Space Center are similar to those that tow aircraft at commercial airports. At KSC, the tractor is used to tow Orbiters, 747 Shuttle carrier aircraft, and other aircraft weighing 372 000 kilograms (820 000 pounds) or less between the Shuttle Landing Facility, the Orbital Processing Facility, and the Vertical Assembly Building. It also tows the ET transporter from the VAB dock area to the ET checkout facility in High Bay 4 of the VAB.

The tractor is 4.9 meters (16 feet) long, 2.4 meters (8 feet) wide, and 2.2 meters (7.3 feet) high. The basic weight is 29 500 kilograms (65 000 pounds); ballasted weight is 49 900 kilograms (110 000 pounds). Its maximum speed is 32 km/h (20 mph) and its towing speed is 8 km/h (5 mph). The towing tractor is powered by a 191-kilowatt (256-horsepower) diesel engine and its transmission is fully automatic with six forward speeds and one reverse speed. A diesel-driven ground-power generator provides the Orbiter (or other aircraft being towed) with 115-volt, 400-hertz, three-phase alternating-current electrical power.

LAUNCH OPERATIONS

Operations at the launch pad after arrival of the Space Shuttle vehicle are controlled from the Launch Control Center. Once in place on the pad support columns, the rotating service structure is extended, the Mobile Launcher Platform and the Space Shuttle vehicle are electrically and mechanically mated with the supporting pad facilities and ground support equipment, and all interfaces are verified. In parallel with these operations, power is applied to the Space Shuttle vehicle and supporting ground support equipment, the launch-readiness test is performed, and hypergolic and helium load preparations are completed. Preliminary cabin closeout will be accomplished as a part of the nonhazardous countdown preparations, followed by pad clearance and such hazardous operations as the servicing of hypergolic, high-pressure-gas, fuel-cell cryogenic systems, and payload fluid servicing, if required.

The Space Shuttle is now ready for the loading of cryogenic propellants and the boarding of the flightcrew for launch.

When the Space Shuttle becomes operational after the Orbital Flight Test (OFT) series,

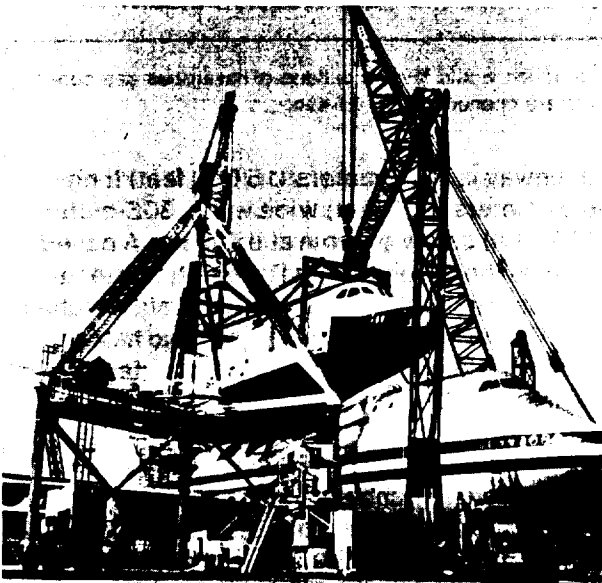

Figure 6-15.—Mate/demate stiffleg derrick (108-KSC-7PC-34).

completion of the hazardous servicing and the RSS retraction will place the vehicle in standby status at approximately $T - 2$ hours in the countdown. The Space Shuttle vehicle will have the capability to be held at this point for up to 24 hours or to proceed with the terminal countdown following a clearance to launch.

The final 2 hours of the countdown include final mission software update, completion of propellant system purges, propellant line chill, loading of liquid hydrogen and liquid oxygen aboard the External Tank, crew entry, terminal sequence, and lift-off.

Prelaunch testing and countdown procedures will be more conservative during the Orbital Flight Test period while experience is gained with ground support and flight systems. The countdown for the first Orbital Flight Test provides timing for 5 hours of planned operations, but countdown clock holds will increase the time available to 6 hours 20 minutes to allow additional time for contingencies. The primary tasks performed (table 6-1) include servicing the External Tank, assisting flightcrew boarding and cabin closeout, performing final communications checks, performing flight control system checks using the onboard auxiliary-powered hydraulic unit, starting the main engines, and initiating the launch by ignition of the Solid Rocket Boosters.

The launch sequence and ascent profile given in table 6-II is typical for a Space Shuttle mission being launched on an azimuth of 81.36° (measured clockwise from north) to place the Orbiter in a 277-kilometer (172-mile) high circular orbit with a 38° inclination. This orbit will be achieved by two OMS maneuvers following completion of the SRB and SSME burns.

Lift-off will occur 0.3 second after ignition of the Solid Rocket Boosters and release of the Space Shuttle vehicle from the eight holddown posts supporting it on the Mobile Launcher Platform. Tower clearance will occur at $T + 6.5$ seconds.

The Solid Rocket Boosters will be jettisoned after 2 minutes of flight and will splash down in the Atlantic Ocean approximately 272 kilometers (169 miles) downrange from Launch Complex 39. The External Tank will be jettisoned 8 minutes 50 seconds into the flight on a suborbital trajectory that will bring it to impact in the Indian Ocean approximately 58 minutes after lift-off.

TABLE 6-I.— TYPICAL ORBITAL FLIGHT TEST LAUNCH COUNTDOWN SEQUENCE

Countdown time	Function
T - 11 hr	Start retraction of rotating service structure (completed by T - 7 hr 30 min)
T - 5 hr 30 min	Enter 6-hr built-in hold, followed by clearing of pad
T - 5 hr	Start countdown; begin chilldown of liquid oxygen/liquid hydrogen transfer system
T - 4 hr 30 min	Begin liquid oxygen fill of External Tank
T - 2 hr 50 min	Begin liquid hydrogen fill of External Tank
T - 2 hr 4 min	1-hr built-in hold, followed by crew entry operations
T - 1 hr 5 min	Crew entry complete; cabin hatch closed
	Start cabin leak check (completed by T - 25 min)
T - 30 min	Secure white room; ground crew retires to fallback area by T - 10 min
	Range safety activation/Mission Control Center guidance update
T - 25 min	Mission Control Center/crew communications checks; crew given landing weather information for contingencies of return-to-launch-site abort or abort once around
T - 20 min	Load flight program
T - 9 min	10-min built-in hold (There is also a 5-min hold capability between T - 9 and T - 2 min and a 2-min hold capability between T - 2 min and T - 27 sec.)
T - 9 min	Go for launch/start launch processing system ground launch sequencer (automatic sequence)
T - 7 min	Start crew access arm retraction
T - 5 min	Activate Orbiter hydraulic power units (APU's)
T - 4 min 30 sec	Orbiter goes to internal power
T - 3 min	Gimbal main engines to start position
T - 2 min 55 sec	External Tank oxygen to flight pressure
T - 2 min 30 sec	Retract External Tank gaseous oxygen vent arm
T - 1 min 57 sec	External Tank hydrogen to flight pressure
T - 27 sec ^a	Latest hold point if needed (Following any hold below the T - 2 min mark, the countdown will be automatically recycled to T - 9 min.)
T - 25 sec	Activate Solid Rocket Booster hydraulic power units; initiative for management of countdown sequence assumed by onboard computers; ground launch sequencer remains on line supporting
	Solid Rocket Booster nozzle profile conducted
T - 18 sec	Solid Rocket Booster nozzle profile conducted
T - 3.46 to 3.22 sec	Main engines start
T - 0	Main engines at 90 percent thrust
T + 2.64 sec	Solid Rocket Booster fire command/holddown bolts triggered
T + 3 sec	LIFT-OFF

^aThis hold cutoff point could come as early as T - 35 sec if wind direction would favor a buildup of hazardous gas concentrations (hydrogen vapors) in the Orbiter's payload bay when its vents are opened at T - 27 sec.

The first OMS burn will place the Orbiter in an orbit with an apogee of 277 kilometers (172 miles) and a perigee of 96.2 kilometers (59.8 miles). The second OMS burn occurs near orbital apogee and will place the Orbiter into a near-circular orbit of approximately 277 kilometers (172 miles) above the Earth.

SHUTTLE LANDING FACILITY

When the Space Shuttle Orbiter returns to Earth from its mission in space, it will land at KSC on one of the world's most impressive runways. The concrete runway of the Shuttle Landing Facility (SLF) is located northwest of the Vehicle Assembly Building on a northwest/southeast alignment (330° northwest/150° southeast) (fig. 6-16).

The runway is 4572 meters (15 000 feet) long and 91 meters (300 feet) wide with a 305-meter (1000-foot) safety overrun at each end. A paved runway at the Dryden Flight Research Center at the Edwards Air Force Base in California matches the KSC runway in length and width and has an overrun of 8 kilometers (5 miles) that extends into a dry lake bed.

The Shuttle Landing Facility runway is 40.6 centimeters (16 inches) thick in the center with the thickness diminishing to 38 centimeters (15 inches) on the sides. The runway is not perfectly flat but has a slope of 61 centimeters (24 inches) from centerline to edge. Underlying the concrete paving, completed in late 1975, is a 15.2-centimeter (6-inch) thick base of soil cement.

The runway is grooved to prevent hydroplaning in wet weather. The Orbiter's wheels will run across 6.35-millimeter (0.25-inch) wide grooves that cross the runway at intervals of 2.86 centimeters (1.125 inches). The grooves, together with the slope of the runway from centerline to edge, provide rapid drainoff of any water from a heavy Florida rain to help combat hydroplaning. The total length of the grooves is 13 600 kilometers (8450 miles).

In general terms, the SLF runway is roughly twice as long and twice as wide as average commercial landing facilities, although a number of domestic and foreign airports have landing strips far exceeding average dimensions. The SLF includes a 168- by 150-meter (550- by 490-foot) aircraft parking apron, or ramp, located near the southeastern end of the runway. The landing facility is linked with the Orbiter Processing Facility by a 3.2-kilometer (2-mile) towway.

Located on the northeast corner of the SLF ramp area is the mate/demate device (M/DD) used to raise and lower the Orbiter from its 747 carrier aircraft during ferry operations (fig. 6-17). The device is an open-truss steel structure with the hoists and adapters required to mate the Orbiter

to and demate it from the 747. Such a mating or demating operation must be performed before and after each ferry flight. Movable platforms for access to certain Orbiter components and equipment for jacking the Orbiter are also provided.

The mate/demate device is intended for use in the open air and is designed to withstand winds of up to 200 km/h (125 mph). Lightning protection is included. The M/DD is 46 meters (150 feet) long, 28 meters (93 feet) wide, and 32 meters (105 feet) high. A similar device is in use at the NASA Dryden Flight Research Center in California and a third will be erected at the Vandenberg Air Force Base in California in support of Space Shuttle operations there.

A portable stiff-leg derrick system was designed and built by KSC for use at the Marshall Space Flight Center in Alabama. The portable system is also available for use in retrieving an Orbiter compelled to make a landing at a number of contingency sites located around the world.

Also located at the SLF is a landing aids control building near the aircraft parking apron.

TABLE 6-II.— SPACE SHUTTLE LAUNCH EVENTS

Event	Time, min:sec	Geodetic altitude, ^a km (mi)	Inertial velocity, km/h (mph)	Range, km (mi)
SSME ignition	−00:03.46	^b 56 (184)	^c 1 471 (914)	0 (0)
SRB ignition	00:03	^b 56 (184)	^c 1 471 (914)	0 (0)
Begin pitchover	00:07	^b 166 (545)	1 476 (917)	0 (0)
Maximum dynamic pressure	01:09	13.4 (8.3)	2 662 (1 654)	6.4 (4)
SRB separation	02:04	47.3 (29.4)	5 533 (3 438)	38.1 (23.7)
Main engine cutoff	08:38	117.5 (73)	28 163 (17 500)	1 335 (829.3)
External Tank separation	08:50	118.3 (73.5)	28 160 (17 498)	1 427 (886.6)
OMS-1 ignition	10:39	126 (78.3)	28 129 (17 479)	2 221 (1 380)
OMS-1 cutoff	12:24	133.9 (83.2)	28 309 (17 591)	2 993 (1 860)
OMS-2 ignition	43:58	279.4 (173.6)	27 682 (17 201)	15 731 (9 775)
OMS-2 cutoff	45:34	280.3 (174.2)	27 875 (17 321)	16 526 (10 269)

^aAltitude referenced to Orbiter center of gravity above the geodetic representation of the Earth's surface.

^bIn meters (feet).

^cRotational velocity of Earth at KSC latitude of 28.5° N.

LANDING SYSTEM

The Orbiters will be guided automatically to safe landings by a sophisticated microwave scanning beam landing system (MSBLS) (fig. 6-18). At deorbit, the Space Shuttle Orbiter is committed to a landing at a precise point on a relatively small target. Unlike conventional aircraft, it lacks propulsion and the high-speed glide to landing must be accomplished perfectly the first time. The energy management procedures to do this require the most precise and up-to-date vectors

that can be derived from available navigation systems.

Landings may be made on the runway from the northwest to the southeast (Runway 15) or from the southeast to the northwest (Runway 33), and MSBLS ground stations are duplicated to permit an approach from either direction. A decision on which runway is to be used must be made before the Orbiter's altitude drops below 41 150 meters (135 000 feet) and its velocity falls below 8230 km/h (5115 mph).

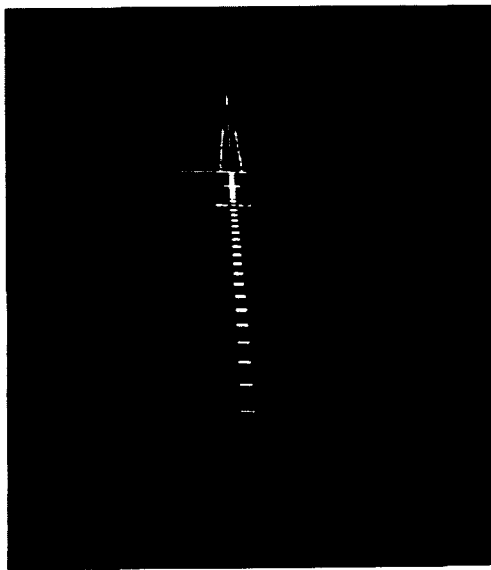

- 1 - ACCESS ROAD A
- 2 - ACCESS ROAD B
- 3 - ACCESS WAY
- 4 - AIRFIELD LIGHTING VAULT
- 5 - CRASH/FIRE/RESCUE
- 6 - KENNEDY PARKWAY
- 7 - LANDING AIDS CONTROL BUILDING
- 8 - GROUND SUPPORT EQUIPMENT POWER PANEL
- 9 - MATE/DEMATE DEVICE
- 10 - METEOROLOGICAL EQUIPMENT PAD
- 11 - MICROWAVE SCANNING BEAM LANDING SYSTEM (MSBLS) ELEVATION STATION RUNWAY 15
- 12 - MSBLS ELEVATION STATION RUNWAY 33
- 13 - MSBLS AZIMUTH/DISTANCE MEASURING EQUIPMENT STATION RUNWAY 15
- 14 - MSBLS AZIMUTH/DISTANCE MEASURING EQUIPMENT STATION RUNWAY 33
- 15 - ORBITER TARGET AIM POINT
- 16 - PARKING APRON
- 17 - RF COMMUNICATIONS TOWER
- 18 - TELEVISION TOWER AND EQUIPMENT
- 19 - TOW-WAY TO VEHICLE ASSEMBLY BUILDING

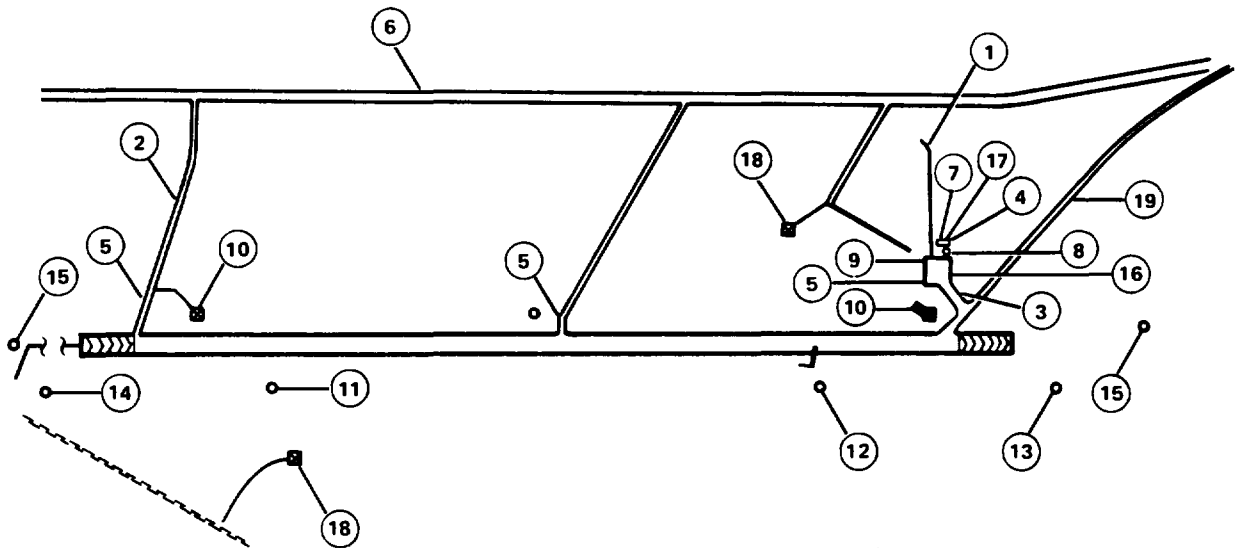

Figure 6-16.—Shuttle Landing Facility at KSC (108-KSC-376C-42/23).

Each of the two MSBLS ground stations consists of two sites adjacent to the landing runway. An elevation site is located approximately 1067 meters (3500 feet) in from the runway threshold and an azimuth/distance-measuring equipment site is located approximately 396 meters (1300 feet) beyond the stop end of the runway. The ground stations are located 94 meters (308 feet) to the west of the runway's centerline. In addition, equipment is provided for remote control and monitoring and for remote display of maintenance and monitor information.

The azimuth/distance-measuring sites on the far end of the runway send signals that sweep 15° on each side of the landing path to provide directional and distance data. Signals from the companion shelter near the touchdown point sweep the landing path to provide elevation data up to 30°. Equipment onboard the Orbiter receives these data and automatically makes any needed adjustments to the glide slope.

LANDING OPERATIONS

When all facilities and systems are ready for landing, the deorbit will be initiated at approximately 60 minutes before landing and Orbiter entry will occur at approximately 30

minutes before touchdown (fig. 6-19(a)). The landing approach begins with retrofire and continues with the Orbiter engaged in terminal-area-energy-management maneuvers after it is in the Earth's atmosphere. These maneuvers are designed to place the Orbiter in a favorable position to intercept the landing approach corridor at the correct altitude and speed. Final landing guidance with the microwave scanning beam landing system (fig. 6-19(b)) begins at an altitude of 4074 meters (13 365 feet), a range from the runway threshold of about 12 kilometers (7.5 miles), and a velocity of about 682 km/h (424 mph). The time from touchdown will be 86 seconds. This phase of the flight will be fully automatic with the crew monitoring, supervising, and backing up the MSBLS. The final approach will have an initial glide slope of 22° (more than 7 times as steep as the 3° slope of a commercial airliner on a straight-in approach) and flare or pull-up maneuvers will be required to bring the Orbiter to the final glide slope of 1.5° and touchdown speed of 346 km/h (215 mph). The crew will initiate landing gear deployment 22 seconds before touchdown at an altitude of 91.4 meters (300 feet) at a distance of 1 695 meters (5560 feet) from the runway threshold. The targeted touchdown point is 841 meters (2760 feet) past the threshold of the runway.



Figure 6-17.—Mate/demate device (108-KSC-79P-38).

ORIGINAL PAGE IS
OF POOR QUALITY

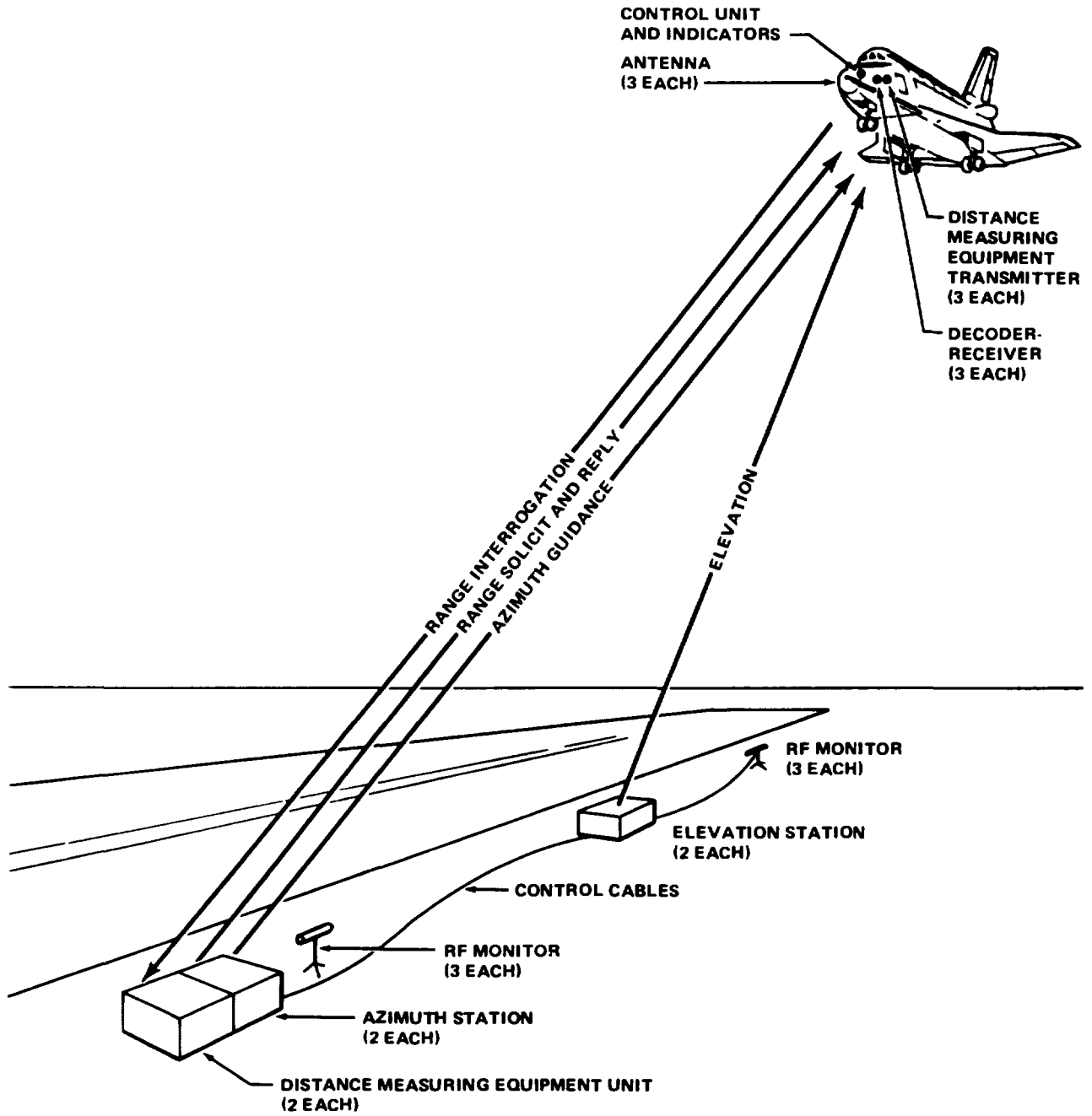
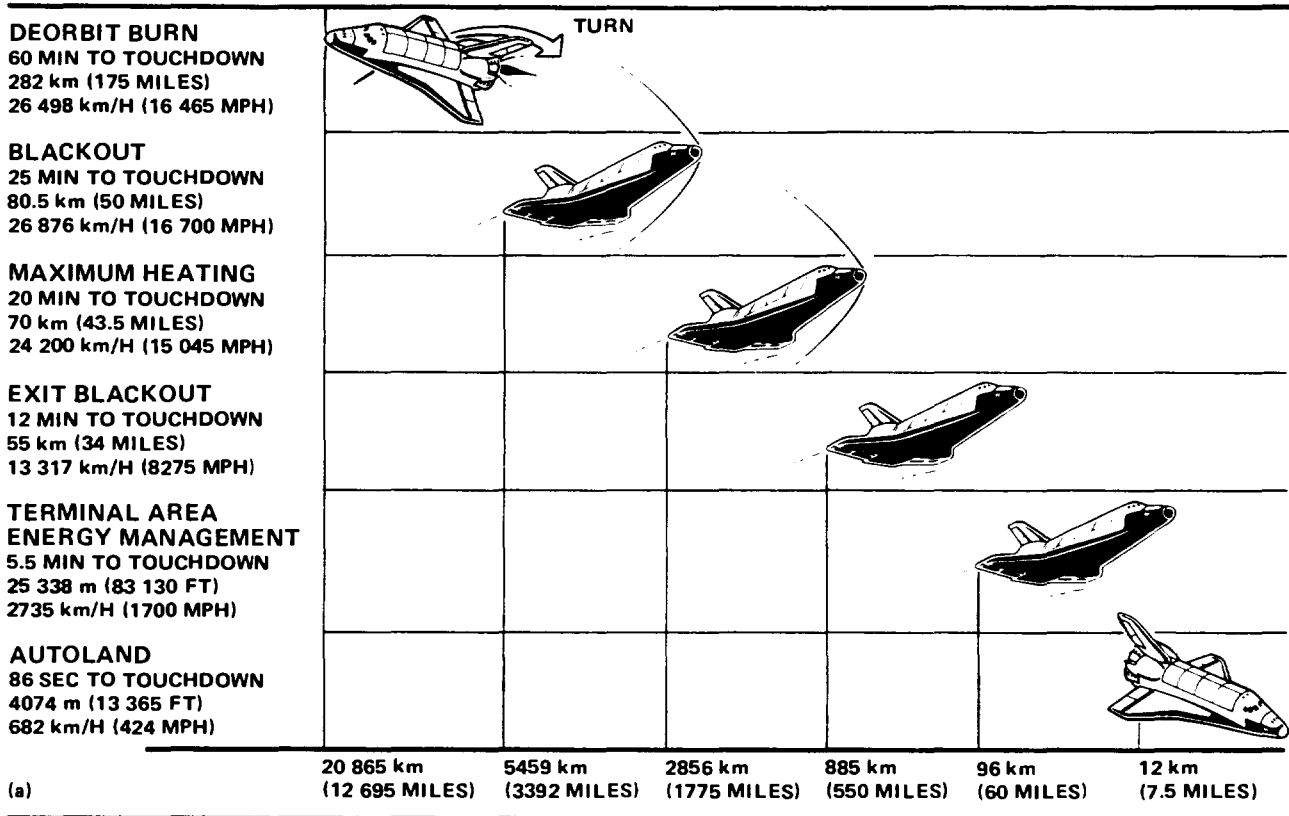
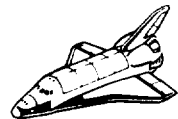

Figure 6-18.—Microwave scanning beam landing system.



AUTOLAND INTERFACE
 86 SEC TO TOUCHDOWN
 12 km (7.5 MILES) TO RUNWAY
 682 km/H (424 MPH)
 4074-m (13 365-FT) ALTITUDE



INITIATE PREFLARE
 32 SEC TO TOUCHDOWN
 3.2 km (2 MILES) TO RUNWAY
 576 km/H (358 MPH)
 526-m (1725-FT) ALTITUDE

22° GLIDE SLOPE

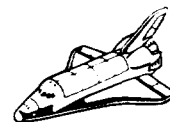

COMPLETE PREFLARE
 17 SEC TO TOUCHDOWN
 1079 m (2540 FT) TO RUNWAY
 496 km/H (308 MPH)
 41-m (135-FT) ALTITUDE

FLARE TO 1.5°

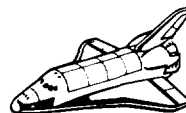

WHEELS DOWN
 14 SEC TO TOUCHDOWN
 335 m (1 100 FT) TO RUNWAY
 430 km/H (268 MPH)
 27-m (90-FT) ALTITUDE

1.5° GLIDE SLOPE



TOUCHDOWN
 689 m (2760 FT)
 FROM END OF RUNWAY
 346 km/H (215 MPH)

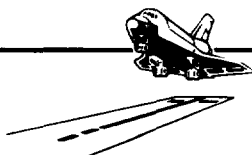

(b)

Figure 6-19.—Reentry burn cycle for the Shuttle.

SOLID ROCKET BOOSTER RECOVERY

Solid Rocket Booster Retrieval and Processing

Associated with Space Shuttle operations at the Kennedy Space Center is the retrieval and refurbishment of the two reusable Solid Rocket Boosters that are burned in parallel with the Orbiter's three main engines to place the Shuttle in orbit. Solid Rocket Booster burnout occurs at T + 2 minutes and separation occurs 4 seconds later at an altitude of 44.3 kilometers (27.5 miles). The boosters begin a 70-second coast to an apogee of 67 kilometers (41.6 miles) and then freefall to an impact zone in the Atlantic Ocean approximately 258 kilometers (160 miles) downrange from Launch Complex 39. The SRB splashdown "footprint" measures approximately 11 by 17 kilometers (7 by 10 miles).

The Solid Rocket Boosters freefall until they reach an altitude of 4700 meters (15 400 feet). At this point, the nose cap is jettisoned and the SRB pilot parachute is deployed. The pilot parachute deploys the 16.5-meter (54-foot) diameter, 499-kilogram (1 100-pound) drogue parachute, which stabilizes and slows the fall of the booster. At an altitude of 2000 meters (6600 feet), the frustum is separated from the SRB forward skirt, deploying the three main parachutes. Each of the main parachutes is 35 meters (115 feet) in diameter and weighs approximately 680 kilograms (1500 pounds) dry and almost twice that when wet. The 74 840-kilogram (165 000-pound) boosters impact in the predetermined splashdown area 6 minutes 54 seconds after lift-off at a velocity of 95 km/h (59 mph).

Waiting to recover the boosters and their various components are two specially designed and constructed retrieval vessels. The two boats — designated the UTC *Liberty* (fig. 6-20) and the UTC *Freedom* — are 54 meters (176 feet) long, have beams 11.3 meters (37 feet) long, have a depth of 4.6 meters (15 feet), and draw 2.7 meters (9 feet) of water.

Of molded steel hull construction, the recovery vessels have sophisticated electronic communications and navigation equipment, including a satellite navigation system, search radars, collision-avoidance sonars with transponders, radars, loran C, vhf and single-sideband high-frequency radio systems, direction finders, fathometers, and gyro compasses. Each vessel has a displacement of 955 metric tons (1052 tons).

At sea, propulsion will be provided by twin diesel engines with a combined power output of 2163 kilowatts (2900 horsepower). Maneuvering ability will be provided by a diesel-driven 317-kilowatt (425-horsepower) bow thruster.

The Hangar AF Disassembly Facility is located on the eastern shore of the Banana River, a shallow arm of the sea where many manatees or sea cows, an endangered species, make their homes. Propulsion in the Banana River will be provided by a 317-kilowatt (425-horsepower) waterjet stern thruster, eliminating the danger of propellers killing or maiming these marine animals.

The vessels will have a sustained speed capability of 24 km/h (13 knots), a range of 11 100 kilometers (6900 statute miles) and a complement of 24 (12 operating crewmembers and 12 retrieval specialists).



Figure 6-20.—The UTC *Liberty* (108-KSC-80PC-205).

Both ships will be used on each Shuttle mission; each ship will recover one SRB casing, three main parachutes, and a frustum-drogue combination. To help locate scattered components, tracking devices have been placed on each one. The SRB casings and each frustum-drogue parachute combination are equipped with radio devices that will emit signals picked up by the recovery vessels' radio direction finder. The three main parachutes will be located by sonar.

Recovery begins with retrieval of the main parachutes. Each recovery vessel has four large deck reels—1.7 meters (5.5 feet) across—each capable of holding one parachute. The parachute's winch lines are fed onto the spool and the parachutes are wound around them like line on a fishing reel.

Retrieval of the frustum/drogue parachute begins in the same way. The drogue parachute is wound around one of the large reels until the 2270-kilogram (5000-pound) frustum is approximately 30 meters (100 feet) from the ship. The drogue parachute shroud lines are then rolled in until the frustum can be hoisted out of the water by a 9-metric-ton (10-ton) crane.

Recovery of the two spent solid booster casings, the last phase of the recovery mission, will be accomplished by using the nozzle plug (fig. 6-21). The nozzle plug is 4.4 meters (14.5 feet) tall and 2.3 meters (7.5 feet) in diameter and weighs 1590 kilograms (3500 pounds). Because it is remotely controlled, the plug can move in any direction. It is powered by six hydraulically driven propellor-type thruster motors. The four thrusters that give the plug its horizontal movement are positioned around the middle of the plug. The other two thrusters are located near the bottom and move the plug up and down. The thrusters propel the plug with a horizontal velocity of 0.9 m/s (3 ft/s), a downward vertical velocity of 0.85 m/s (2.8 ft/s), and an upward vertical velocity of 1.4 m/s (4.5 ft/s).

After the plug is launched overboard, it is moved out to the bobbing solid booster casing tethered

by 183 meters (600 feet) of umbilical cable. Although it is possible to maneuver the plug at a distance of 122 to 137 meters (400 to 450 feet) from the ship, the practical operating range is between 30 and 60 meters (100 and 200 feet).

At the top of the plug is a video camera that allows the operator to view the position of the plug in relation to the casing on a shipboard television monitor. Once it is in position, the plug is lowered to a depth of approximately 44 meters (145 feet). As it descends, the television camera is used to inspect the booster casing for any damage incurred during launch, reentry, or impact. Once it reaches the bottom of the booster, it is inserted and three 0.9-meter (3-foot) metal arms are extended, locking the plug into the booster's throat.

Docking is verified by sensors on the plug's shock mitigation units, located just above the four horizontal thruster motors. Compressed air is then pumped into the water-filled cavity through the umbilical cord at a pressure of up to 517 kilopascals (75 psi). As the water is forced out, the booster will begin its rotation from the vertical to the horizontal. When the water level recedes to a certain level, an inner-tube-type bag is inflated, sealing off the throat of the booster. A 3-meter (10-foot) long dewatering hose is then deployed from the nozzle plug and the remaining water is forced out through it. The booster is then towed back to the KSC Solid Rocket Booster Disassembly Facility.

Solid Rocket Booster Disassembly Facility

The Solid Rocket Booster Disassembly Facility is located in Hangar AF at the Cape Canaveral Air Force Station on the eastern shore of the Banana River (fig. 6-22). Access to the Atlantic Ocean, from which the boosters are retrieved by ship after jettison during the Shuttle launch phase, is provided by the locks at Port Canaveral. A tributary channel from the Disassembly Facility ties in with the main channel on the Banana River to KSC.

Recovery vessels tow the expended boosters in the horizontal position into the Disassembly Facility's offloading area where they are properly centered in a hoisting slip. Mobile gantry cranes on the hoisting slip lift the booster onto a standard-gage tracked dolly for safing and preliminary washing. The nose cone frustums and parachutes are offloaded for processing at other facilities. After safing and washing, the SRB casings are moved into the Disassembly Facility

for disassembly to the level of major elements, consisting of four SRB segments, the aft skirt assembly, and the forward skirt assembly. The segments then undergo final cleaning and stripping before they are shipped to the Vehicle Assembly Building by truck. From there, the segments will be shipped by rail to the prime contractor in Utah for final refurbishing and loading with propellant.

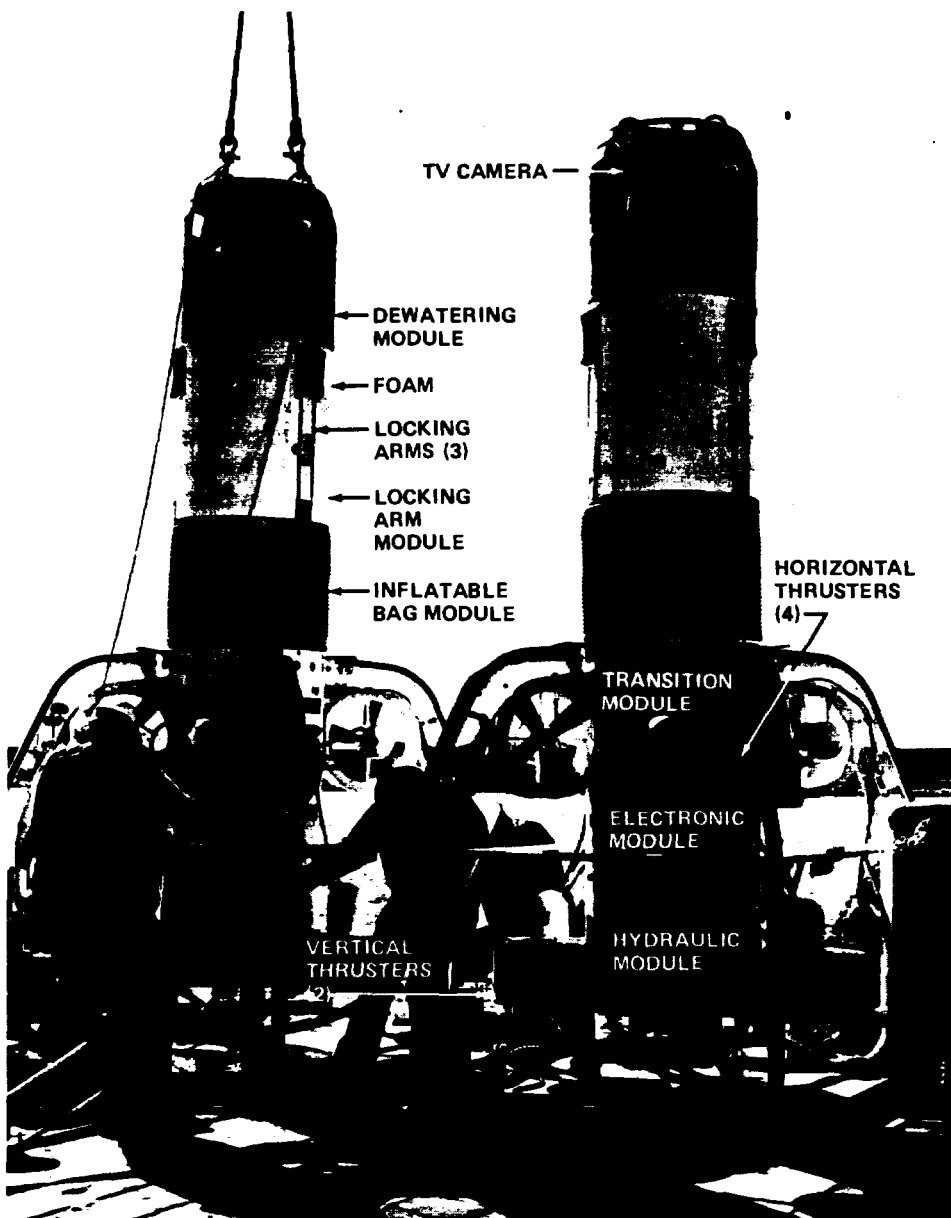

Figure 6-21.—Nozzle plug used in the recovery of the two spent SRB casings (108-KSC-80P-9).

Parachute Refurbishment Facility

The Parachute Refurbishment Facility is located in the KSC Industrial Area to the south of the Operations and Checkout Building. It was formerly a Gemini parachute facility and was also used for a time as the KSC News Center.

Parachute systems recovered concurrently with SRB casing retrieval are delivered to the refurbishment facility on reels provided on the retrieval vessels for that purpose. The parachutes for the Solid Rocket Boosters are washed, dried, refurbished, assembled and stored in this facility. New parachutes and hardware from manufacturers also are delivered to the Parachute Refurbishment Facility.

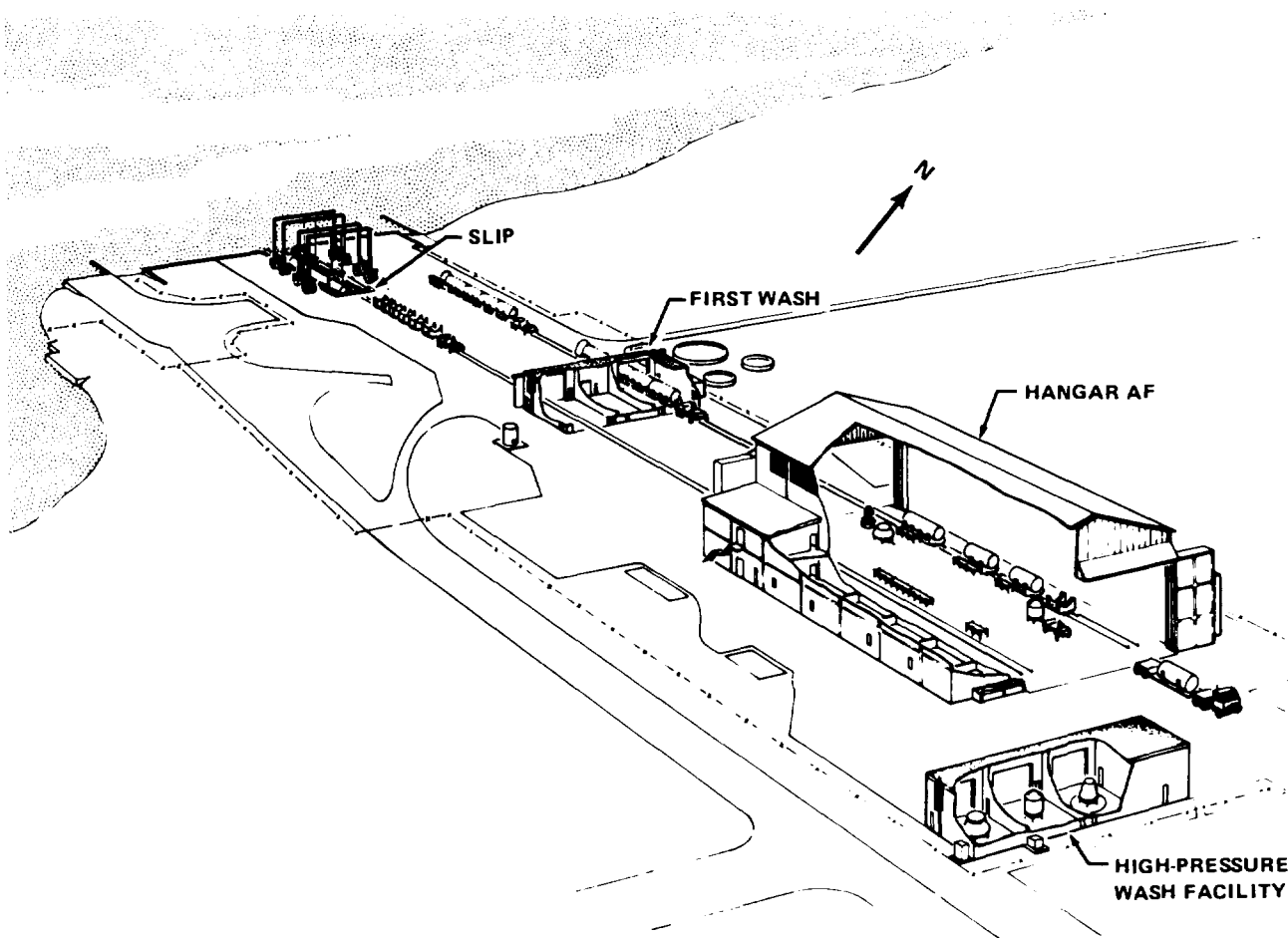
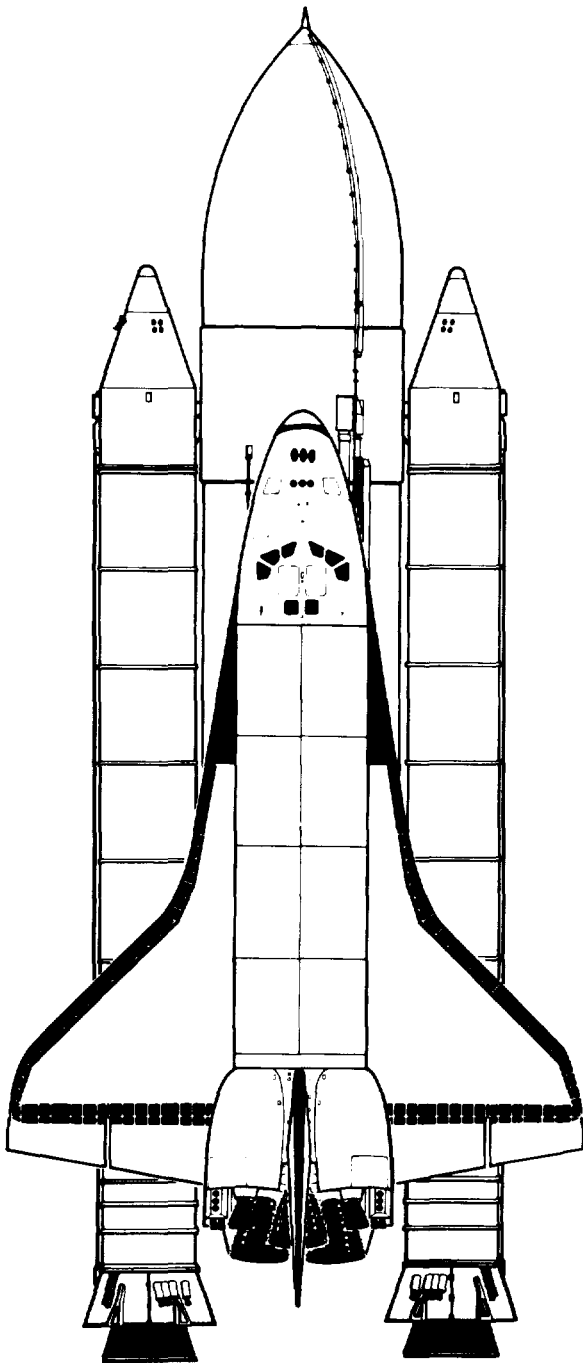

Figure 6-22.—Solid Rocket Booster Disassembly Facility at the Cape Canaveral Air Force Station.

6. MISSION OPERATIONS AND SUPPORT

Tracking and Communications Network

SPACE TRACKING AND DATA NETWORK.....	6-46
KEEPING TRACK.....	6-46
SCAMA.....	6-46
COMPUTERS.....	6-46
TRACKING STATIONS IN THE SKY.....	6-47



PRECEDING PAGE BLANK NOT FILMED

Briefly...

Tracking stations scattered around the world give Orbiter crews contact with Mission Control for several minutes of most orbits. When the new Tracking and Data Relay Satellites are parked at 37 000 kilometers (23 000 miles) over the Equator in the mid-1980's, the Mission Control Center will have almost continuous contact with Orbiter crews.

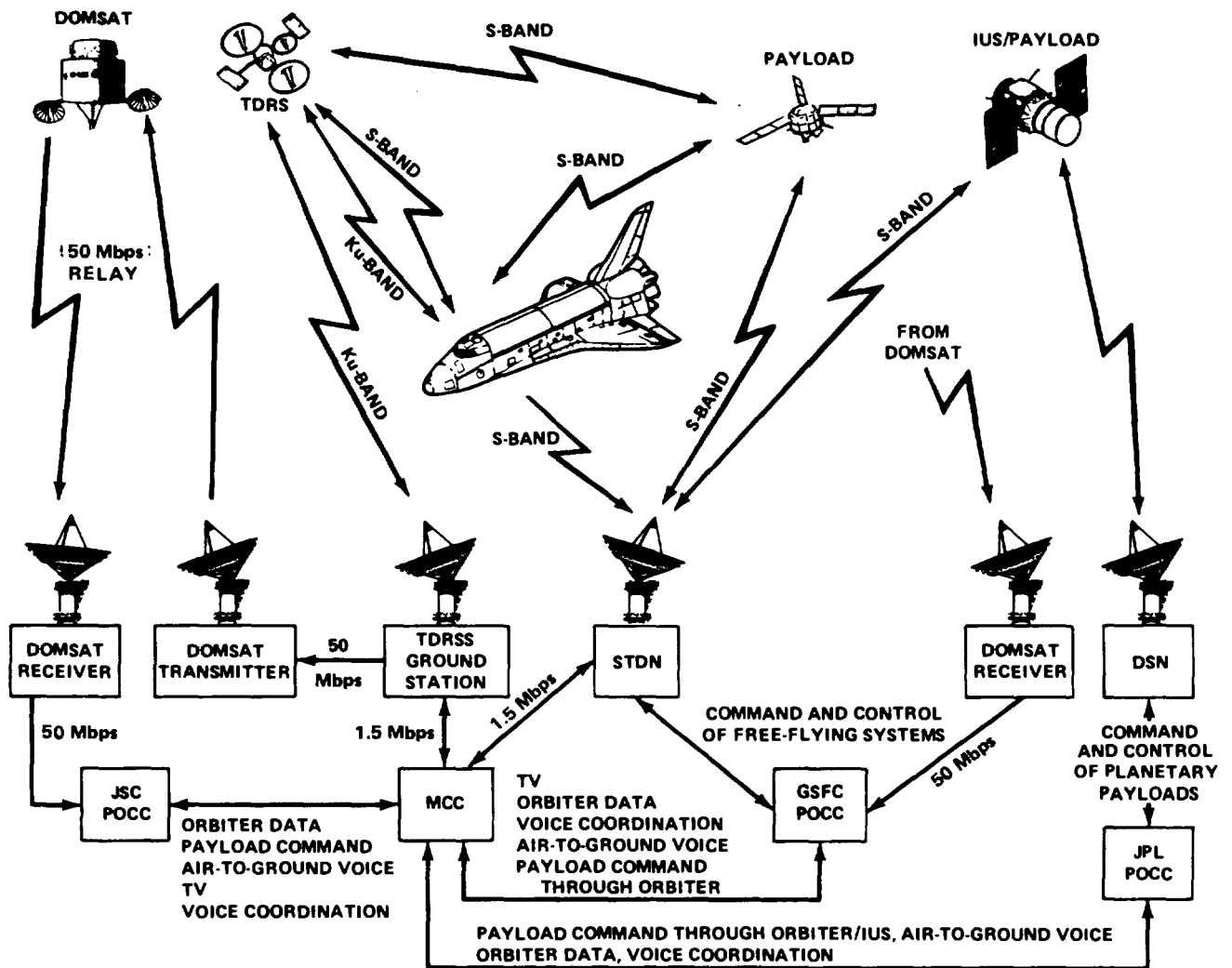

- DOMSAT DOMESTIC SATELLITE
- DSN DEEP SPACE NETWORK
- GSFC GODDARD SPACE FLIGHT CENTER
- IUS INERTIAL UPPER STAGE
- JPL JET PROPULSION LABORATORY
- JSC JOHNSON SPACE CENTER
- MCC MISSION CONTROL CENTER
- POCC PAYLOAD OPERATIONS CONTROL CENTER
- STDN SPACE TRACKING AND DATA NETWORK
- TDRS TRACKING AND DATA RELAY SATELLITE
- TDRSS TRACKING AND DATA RELAY SATELLITE SYSTEM

Tracking and Communications Network

Space Shuttle missions will be linked to Earth by the Space Tracking and Data Network (STDN) operated by the NASA Goddard Space Flight Center (GSFC). Seven new systems have been added to the tracking and communications network to handle the data from Shuttle and Shuttle payloads. The major additions to the tracking and communications network for Shuttle missions are as follows.

1. First digital voice system — Voice links from the Shuttle to ground and from the ground to Shuttle are digital. The conversion from analog to digital will be made in the tracking stations. After conversion, the voice will be handled the same as for earlier manned missions. This new digital system is less immune to "noise" and facilitates voice transmission.

2. "Bent pipe" data flow — All real-time data from the Space Shuttle will go directly from the Orbiter to the Mission Control Center at the NASA Lyndon B. Johnson Space Center (JSC) in Houston. In the bent-pipe mode, all real-time data flows through an electronic "pipeline" directly into Houston without any delay at a tracking site.

3. Tracking and Data Relay Satellite System — The Tracking and Data Relay Satellite System will not be ready for the early Shuttle flights. The work that will ultimately be handled by these satellites will be performed for early Shuttle flights by ground stations. When the system becomes operational in the 1980's, there will be two satellites — or "tracking stations" — in orbit: one over the Atlantic Ocean and one over the Pacific Ocean.

4. Radar tracking for reentry flights to Dryden Flight Research Center, California — Five radars

provided by NASA and the U.S. Air Force at Edwards and Vandenberg Air Force Bases, and at several other west coast sites, will track the Orbiter during its reentry flightpath for landing on the desert. When the first radar "locks" onto Shuttle, the other four "slave" to it and all five perform as one system.

5. Transportable tracking stations — Three special-purpose transportable tracking stations have been added to the basic network for the Space Shuttle. The stations are Ponce de Leon Inlet, Florida (near New Smyrna Beach); Bangor, Maine; and Buckhorn Lake Station, Edwards Air Force Base, California. The station at Ponce de Leon Inlet will back up the Merritt Island station in Florida during powered flight in the event the latter station might experience radio attenuation problems from the solid rocket motor plume. The Bangor site will be used to support high-inclination launchings. The Buckhorn station will support landings at the Dryden Flight Research Center in California.

6. Domestic communications satellites — For the first time in the history of manned space flights, domestic communications satellites (five in all) will be used to electronically tie Earth stations together. The use of domestic communications satellites will also permit 10 to 20 times more data to be transmitted. To support the Space Shuttle, ground terminals for domestic communications satellites are situated at Johnson Space Center, Houston, Texas; Kauai, Hawaii; Goldstone, California; Kennedy Space Center, Florida; Dryden Flight Research Center, California; and Goddard Space Flight Center, Greenbelt, Maryland.

7. Dual voice channels — The voice communications system has been configured for support of two separate voice conversations upward and downward simultaneously.

SPACE TRACKING AND DATA NETWORK

The Space Tracking and Data Network consists of 13 tracking stations situated on four continents (North and South America, Australia, and Europe). The network is operated by the Goddard Space Flight Center in Greenbelt, Maryland (a suburb of Washington, D.C.) for the Office of Tracking and Data Systems at NASA Headquarters. The STDN tracking stations are located as follows:

Ascension Island
Santiago, Chile
Bermuda
Goldstone, California
Guam
Kauai, Hawaii
Madrid, Spain
Merritt Island, Florida
Orroral, Australia (near Canberra)
Quito, Ecuador
Fairbanks, Alaska
Rosman, North Carolina
Winkfield, England

Special-purpose transportable stations are located at Ponce de Leon Inlet, Florida; Bangor, Maine; and Buckhorn Lake Station, Edwards Air Force Base, California. Also supporting the STDN network are several instrumented aircraft. These Air Force aircraft, named Advanced Range Instrumentation Aircraft (ARIA), are situated at various spots around the world where ground stations are unable to support missions.

KEEPING TRACK

The Space Tracking and Data Network stations are equipped with a variety of antennas (9- to 26-meter (30- to 85-foot) diameter), each designed to accomplish a specific task usually in a specific frequency band. Functioning like giant electronic magnifying glasses, the larger antennas absorb radiated electronic signals transmitted by spacecraft in a radio form called telemetry.

The center of all STDN activity is the GSFC Communications Center. More than 3 million kilometers (2 million miles) of circuitry connect the 13 remote sites of the NASA Communications Network (NASCOM) and link the Shuttle to the

JSC Mission Control Center in Houston. The major switching centers in NASCOM are located at the Goddard Space Flight Center, Greenbelt, Maryland; the Jet Propulsion Laboratory, Pasadena, California; Cape Canaveral, Florida; Canberra, Australia; Madrid, Spain; and London, England.

This communications network is composed of telephone, microwave, radio, submarine cables, and communications satellites. These various systems link data flow through 11 countries of the free world with 15 foreign and domestic carriers and provide the required information between tracking sites and the JSC and GSFC control centers. Special wide-band and video circuitry is also utilized as needed. The Goddard Space Flight Center has the largest wide-band system in existence.

SCAMA

The Station Conferencing and Monitoring Arrangement (SCAMA) allows voice traffic managers to "conference" as many as 220 different voice terminals throughout the United States and abroad with talk/listen capability at the touch of a few buttons. The system is redundant, which accounts for its mission support reliability record of 99.6 percent. All Space Shuttle voice traffic will be routed through SCAMA at the Goddard Space Flight Center.

COMPUTERS

Included in the equipment of the worldwide STDN system are 126 digital computers located at the different stations. The computers at these remote sites control tracking antennas, handle commands, and process data for transmission to the JSC and GSFC control centers.

Data from the Shuttle from all the tracking stations around the world are funneled into the main switching computers (Univac 494's) at GSFC where the data are reformatted and transmitted to the Johnson Space Center without delay on special very wide band (1.5 million bits per second) circuits via domestic communications satellites.

Commands generated at the Johnson Space Center are transmitted to the main switching computers at GSFC and switched to the proper tracking station for transmission to the Shuttle. The main switching computers at GSFC have been "rebuilt" to increase their switching or throughput capacity to 10 times greater than that of Apollo.

TRACKING STATIONS IN THE SKY

A revolutionary way of tracking will begin in the early 1980's. The new tracking system is called the Tracking and Data Relay Satellite System (TDRSS). The TDRSS will make its maiden flight aboard a Shuttle in the early 1980's. TDRSS is owned by Western Union Telegraph Company with NASA leasing services for a 10-year period.

When the TDRSS is deployed by the Shuttle, its assignment will be to track Shuttle flights and the various scientific and applications satellites that will ride into orbit aboard a Shuttle. This new breed of "space trackers" will actually be "tracking stations in the sky." They will ultimately replace more than half the existing ground tracking stations.

The TDRSS will consist of two operational satellites in synchronous or stationary orbit above the Equator. The satellites will be spaced approximately 130° apart at longitude 171° W (southwest of Hawaii) and longitude 41° W (northeast corner of Brazil).

A TDRSS ground terminal is located at White Sands, New Mexico, for transmitting all tracking and voice data "live" to the control centers at JSC and GSFC. The White Sands Earth Station, managed and owned by Western Union, will include complex electronic equipment, three 18-meter (60-foot) dish antennas, a number of small antennas, and a dual-processor computer system.

The TDRSS will provide NASA with greatly improved communications to and from Shuttle and Shuttle-launched payloads at greatly reduced cost. An additional advantage is that,

while the worldwide network used for the Mercury and Gemini Earth-orbital missions could track only about 15 percent of the time, the TDRSS will provide coverage in the 85- to 100-percent range.

To ensure operational reliability, a spare TDRSS will be launched into orbit as a backup and positioned at a synchronous altitude midway between the two operational satellites. Still another TDRSS on Earth will be flight qualified, stored, and ready for launching on short notice.

Weighing nearly 2268 kilograms (5000 pounds) in orbit and measuring 17 meters (56 feet) from tip to tip of the solar panels, the TDRSS will be the largest telecommunications satellite ever launched. Each satellite will have two space-deployable antennas 5 meters (16.5 feet) in diameter that unfurl like a giant umbrella. Each antenna weighs approximately 23 kilograms (50 pounds). A ground version of similar size and capability would weigh 2268 kilograms (5000 pounds).

To launch the TDRSS, the Space Shuttle Orbiter will climb to an altitude of 200 kilometers (125 miles), then open its payload bay for the subsequent launch of the TDRSS by an inertial upper stage (developed by the U.S. Air Force) into its final orbit 35 887 kilometers (22 300 miles) above the Equator.

When the TDRSS becomes operational, it will be able to track and communicate simultaneously with 24 low-orbital spacecraft, including Shuttle. The system will be able to handle up to 300 million bits of information per second. Since it takes about 8 bits of information to make one word, this is equivalent to processing 300 14-volume sets of encyclopedias every second.

The TDRSS is being developed for shared use by NASA and Western Union. Major contractors to Western Union are TRW for the satellite and Harris Electronic Systems Division for the satellite-deployable antennas and the ground station in New Mexico. The satellite is designed for a life of 10 years.

6. MISSION OPERATIONS AND SUPPORT

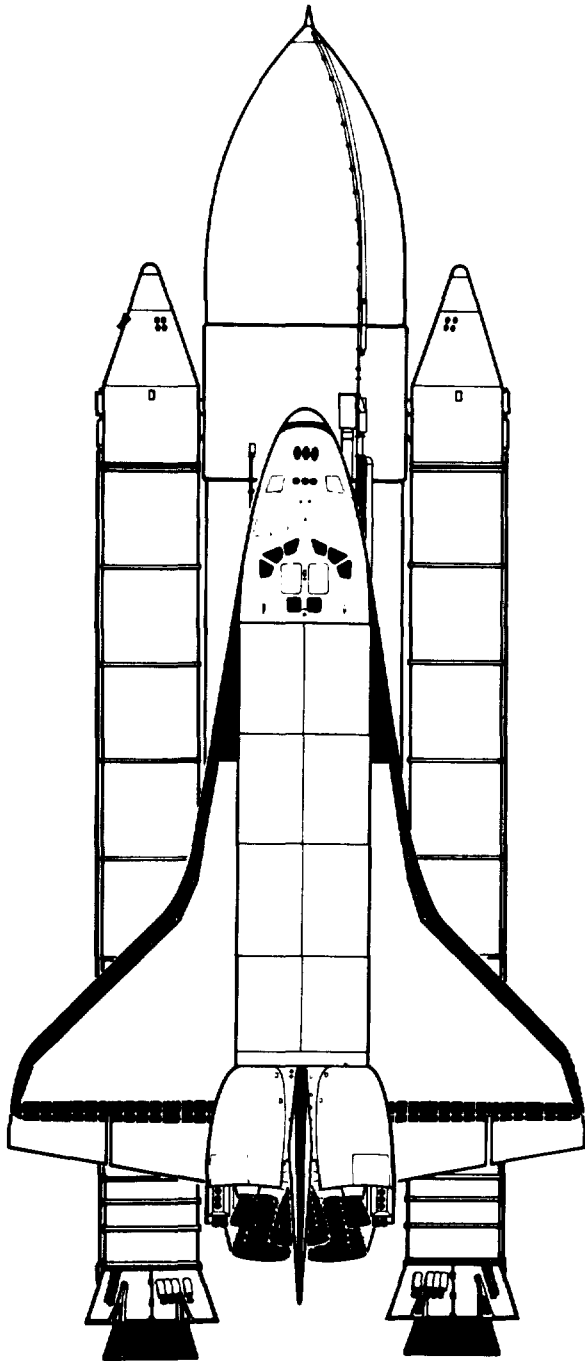

Flight Operations and Mission Control

PAYLOAD OPERATIONS CONTROL CENTER...	6-51
MISSION CONTROL CENTER SYSTEMS.....	6-51
Communications Interface System.....	6-51
Shuttle Data Processing Complex.....	6-52
Display Control System.....	6-53
MISSION CONTROL CENTER FLIGHT CONTROL FUNCTIONS AND POSITIONS.....	6-53
Planning and Operations Management Team.....	6-53
Flight Control Team.....	6-54
Multipurpose Support Team.....	6-54
External Interfaces.....	6-54

PRECEDING PAGE BLANK NOT FILMED

Briefly...

As in previous space programs, the Johnson Space Center will again be the central control point for Space Shuttle missions. Control center operations for Shuttle will differ from those of past programs in that the emphasis will be on the planning and management of operations rather than on flight control. Payloads and related systems will be controlled from the Jet Propulsion Laboratory, the Goddard Space Flight Center, or the Johnson Space Center.



Flight Operations and Mission Control

PAYLOAD OPERATIONS CONTROL CENTER

Three Payload Operations Control Centers (POCC's) have been designated by NASA.

Payload type	POCC location
Planetary	Jet Propulsion Laboratory
Earth-orbital free flyers	Goddard Space Flight Center
Spacelab and attached payloads	Johnson Space Center

Each Payload Operations Control Center will be equipped with the necessary command, display, and communications equipment for control of payloads and related flight systems.

MISSION CONTROL CENTER SYSTEMS

The Mission Control Center at Houston (MCC-H) is the central control point for the Space Shuttle. The MCC-H is composed of the computer complex, the flight control rooms, and a number of staff support rooms surrounding the flight control rooms.

The MCC-H computer complex is divided by function into three systems: the Communications Interface System (CIS), the Shuttle Data Processing Complex (SDPC), and the Display Control System (DCS).

Communications Interface System

The Communications Interface System gives the Mission Control Center at Houston wide flexibility for communications routing. It is a combined facsimile, voice, teletype, and video switchboard — all of which are programmable. Data — both real time and delayed — come to the MCC-H from different sites and are sent from the MCC-H to different locations. The Communications Interface System uses computers to format and compress outgoing data and to route it correctly; it also reformats and decodes incoming data and forwards it to the

proper computer. The interface system has additional capabilities to restore data to its proper time format. Air-to-ground (A/G) voice and MCC-H in-house intercommunications systems are also handled and processed by this system.

The following types of communications are handled by MCC-H.

Voice.— The Mission Control Center at Houston will control the configuration and use of two air-to-ground voice channels. The MCC-H normally communicates with the Orbiter crew on the A/G Orbiter Operations channel. The Payload Operations Control Center normally communicates with the crew for payload operations on the A/G Science Operations channel.

Telemetry.— Space Shuttle real-time telemetry contains Space Transportation System (STS) systems data and Orbiter computer data. The telemetry can be sent at a low bit rate of 64 kilobits per second or a high bit rate of 128 kilobits per second.

Spacelab subsystems and housekeeping data are routed to the Orbiter real-time telemetry system and from there to the MCC-H. Spacelab caution-and-warning indications will be displayed in both the Spacelab and the Orbiter. Scientific data are transmitted in real time or by delayed playback on the Orbiter Ku-band system to the Tracking and Data Relay Satellite or on the Orbiter S-band frequency-modulated system to the ground tracking network.

Provisions are made for telemetry communications between the Orbiter and detached payloads and upper stages. This telemetry is relayed to MCC-H through the Tracking and Data Relay Satellite System (TDRSS) as long as the "free flyer" is in the vicinity of the Orbiter. Once a satellite is put in orbit and its operation is verified, the Orbiter is no longer involved.

Video.— Television is available from the Orbiter cockpit camera, from one of four payload-bay television cameras, or from an attached payload. The crew may select and view as many as four cameras. The Mission Control Center at Houston can select two of the channels that the crew has already selected for transmission via S-band or Ku-band through the TDRSS to the ground.

Command.— The STS ground command system is centralized at the Mission Control Center in Houston. All commands to the Orbiter or through the Orbiter to payloads are under direct control of the MCC-H.

There are two types of Orbiter commands, the buffered (two stage) and the nonbuffered (one stage). Single-stage commands are executed immediately after they are received onboard the Orbiter. For two-stage commands, the first stage of the command is loaded in a buffer in the Orbiter computer system until it can be telemetered and reviewed by MCC-H. The second stage of the command is an "execute," which is uplinked to complete the first-stage buffer. All critical STS and payload commands will be two-stage commands.

Network stations do not have the capability to store or process commands. All commands sent through the Ground Spacecraft Tracking and Data Network (GSTDN) are uplinked immediately after they are received from MCC-H.

Tracking.— The Orbiter S-band system provides for one-way and two-way Doppler range computations. The Orbiter S-band phase-modulated transponder retransmits the received S-band signal. The tracking stations and the TDRSS extract range and range-rate tracking data and pointing coordinates and forward them to the MCC-H. The MCC-H then uses this independent source of tracking data to compute navigation state vectors for comparison with those obtained from the Orbiter through telemetry.

Shuttle Data Processing Complex

The Shuttle Data Processing Complex processes communication, command, trajectory, and telemetry data. The computers are designed to support mission-critical events (such as launch and landing) and provide a batch processing capability to support software development and checkout during non-real-time support periods. In a critical mission configuration, the system uses one of its three processors as the mission computer for support of time-critical computing. The second processor is used as a dynamic standby (receiving input and performing computations but with the output inhibited), and

the third serves as a backup. This arrangement ensures a reliability of 99.95 percent for a 50-hour continuous period.

The Shuttle Data Processing Complex is one of the most sophisticated real-time systems in use. The command and control functions of the system consist of a set of four applications programs, totaling about 600 000 lines of programming. These programming lines are the computer instructions that process the telemetry data coming into the control center into meaningful information that can be used by flight controllers.

A special program enables the dynamic standby processor to freeze the mission computer, reproduce its contents from active and memory registers, synchronize itself to the operations being performed in the mission computer, and begin operation as the mission computer.

Data processing programs.— Four applications programs cover most of the operational capabilities of the Shuttle Data Processing Complex: trajectory, telemetry, command, and network communications.

The trajectory processing program determines, predicts, and plans Orbiter trajectories so controllers can evaluate the trajectory and analyze alternatives during the launch, orbit, and entry phases and during contingencies such as an abort.

The telemetry processing program performs validation, calibration, and special computations on telemetry data. It also performs real-time display through the Display Control System and maintains data in memory. This program also keeps track of the data flowing through the processor.

The command processing program generates, formats, and transmits Orbiter real-time commands originating from MCC-H flight control consoles. It generates, formats, and transmits Orbiter stored-program commands maintained in tape files or computer core storage and maintains a historical record of network management commands. It generates, formats, and transmits computer loads to be uplinked to the Orbiter onboard computers and maintains a record of the contents of the Orbiter computer commands.

The network communications processing program monitors circuits; routes and formats data within the computer complex itself; and manages and controls the input of the computing system.

Data processing equipment.— The Shuttle Data Processing Complex has three IBM 370/168-1 computers. These mainframe computers are capable of processing 3 million instructions per second.

Display Control System

The Display Control System provides the link between the information being processed in the computer and the presentation of data on strip-chart recorders, scribing plotboards, event lights (similar to warning lights on automobiles), and the digital television system. The digital television system presents information in tabular form on television "pages" or channels. The system allows console operators to request data and specify the manner in which it is presented. Most of the data is available on the digital television system, which takes up most of the equipment in the control system.

MISSION CONTROL CENTER FLIGHT CONTROL FUNCTIONS AND POSITIONS

The Mission Control Center operations for the Space Shuttle are different from those of all previous programs in that operations planning and management is the main task and flight control, with the associated systems monitoring, is greatly decreased.

The Shuttle vehicle flight control and coordination with the Payload Operations Control Center (at the Goddard Space Flight Center, the Jet Propulsion Laboratory, and the Johnson Space Center) are performed from a flight control room. The flight control team, headed by a flight director, supports the vehicle and payload operations from the terminal countdown through launch, insertion, orbital operations, reentry, landing, and rollout.

The support provided by the multipurpose support teams (MPST's) is divided into two main categories: preflight planning and real-time

support. The individual teams are dedicated to a specific discipline; therefore, their activity is a combination of planning and real-time support.

The maximum operations support required of the flight control and multipurpose support teams consists of up to three simultaneous operations, which can include combinations of real-time operations, a simulation, or pad support but no more than two actual flights.

Planning and Operations Management Team

The planning and operations management team (POMT) performs the vital function of managing the JSC preflight operations planning and is responsive to the JSC Shuttle Payload Integration and Development Program Office (SPIDPO) in performing this function. The management team is responsible for the detailed development, planning, scheduling, and statusing of all STS flights. The main POMT functions are as follows:

1. Communications and data management
2. Shuttle flight status management
3. Payload integration
4. Headquarters operations office representation
5. Medical management
6. Ground data systems management
7. Crew activities integration
8. Public affairs management
9. Training integration
10. Flight design and scheduling
11. Department of Defense representation
12. SPIDPO representation

Staffing for the POMT includes the following positions:

1. STS operations director
2. Communications/data manager
3. Shuttle flight status manager
4. Payload integrator
5. Headquarters representative
6. Ground data systems manager
7. Crew activity integrator
8. Public affairs officer
9. Training officer
10. Flight design and scheduling manager
11. Department of Defense representative
12. Medical representative
13. SPIDPO representative

Flight Control Team

Within the Mission Control Center, all real-time STS flight control responsibility is provided by the flight control team. Teammembers are assigned to a flight approximately 9 weeks before launch.

Launch/landing unique support.— The basic onorbit flight control team support is augmented with systems and trajectory experts for the launch, entry, and landing phases. For launch, entry, and landing phase support, the flight control team is composed of the following:

1. Flight director
2. Communications systems engineer (INCO)
3. Environmental/consumables mechanical engineer (EECOM)
4. Flight computer systems engineer
5. Avionics systems engineer
6. Propulsion systems engineer
7. Flight dynamics officer (FDO)
8. Trajectory officer (TRAJ)
9. Flight activities officer (FAO) (will also act as crew communicator if required)
10. Public affairs officer

Orbital support.— Following orbital stabilization of STS systems and trajectory conditions, the launch team support terminates and the orbit team continues support. The orbit team consists of the following:

1. Flight director
2. Communications systems engineer
3. Flight activities officer
4. Payload officer

Multipurpose Support Team

The multipurpose support teams support the planning and operations management team and the flight control teams concurrently. They are dedicated to specific functions. The multipurpose support rooms (MPSR's) contain communications and computer-driven display equipment that can be used by specialists in vehicle systems support (EECOM and guidance and propulsion), payload support systems, natural environment, communications and data management, crew activities, configuration/logistics, trajectory and

flight design, flight scheduling, training support, ground data systems, medical support, and operations integration and requirements.

Staffing for the multipurpose support team includes the following positions:

1. Guidance and propulsion engineer
2. Avionics systems engineer
3. Main propulsion system engineer
4. Main engine controller engineer
5. Orbital maneuvering system/reaction control system engineer
6. Controls (flight control system) engineer
7. Sensors engineers
8. Data processing system engineer
9. Environmental, mechanical, and electrical system engineers
10. Payload support systems integrator
11. Natural (Earth) environment engineer
12. Crew activities integrator
13. Configuration/logistics engineer
14. Trajectory and flight design representative
15. Ground data systems manager
16. INCO engineer
17. Flight data manager
18. Assistant for flight data requests

The four EECOM positions (number 9) and their responsibilities are as follows.

1. EPS: Electrical power system (EPS) fuel cells and electrical power distribution system
2. APU/HYD: Auxiliary power unit/hydraulics (APU/HYD) systems, structural and mechanical systems, and landing systems
3. Thermal: Atmosphere revitalization system water loops, active thermal control subsystem, and structural temperatures
4. Life support: Waste management system; potable water system; purge, vent, and drain systems; food management; extravehicular activity and airlock; power reactant supply and distribution; atmospheric revitalization pressure control system; and ventilation systems

External Interfaces

Real-time interfaces for operations and planning are required with various organizations external to the Johnson Space Center throughout the STS operations phase.

Launch sites.— The launch sites at the Kennedy Space Center (KSC) and the Vandenberg Air Force Base (VAFB) provide the trajectory and flight design MPSR personnel with site, vehicle, and launch schedule status information from which Mission Control Center and line organization personnel can determine the impact on overall planning and operations.

Landing airfields.— The trajectory and flight design MPSR representatives maintain liaison with all landing airfields (primary, secondary, and contingency) to maintain current airfield configuration and support capabilities as they relate to STS operations planning.

Department of Defense.— The Department of Defense has authority to use military airfields, facilities, and ground support. It provides military aircraft and ship support for logistics, special studies, and search-and-rescue operations.

Federal Aviation Agency.— The Federal Aviation Agency (FAA) is advised of flight status.

The FAA provides airspace reservations for the Orbiter and carrier aircraft over the United States and interfaces with the International Civil Aviation Organization (ICAO) for airspace reservations over international waters.

U.S. State Department.— The U.S. State Department coordinates support from foreign countries pertaining to Orbiter landings on foreign soil and overflight clearances over foreign soil for logistics aircraft.

Network Operations Control Center.— The GSFC Network Operations Control Center (NOCC) is the focal point for Space Tracking and Data Network (STDN) support. STDN management, scheduling, and voice/data interface are controlled by the NOCC.

U.S. Coast Guard.— The configuration and logistics support MPSR representatives maintain liaison with the U.S. Coast Guard in case search-and-rescue operations require their aid in locating an Orbiter.



**7. FLIGHTCREW COMPLEMENT
AND CREW TRAINING**

PRECEDING PAGE BLANK NOT FILMED

Briefly...

Flying in space is like parachute jumping: you have to do it right the first time. The Orbiter commander, pilot, mission specialist and as many as four payload specialists train together in a variety of simulators and training facilities until their flight plan becomes second nature to them.

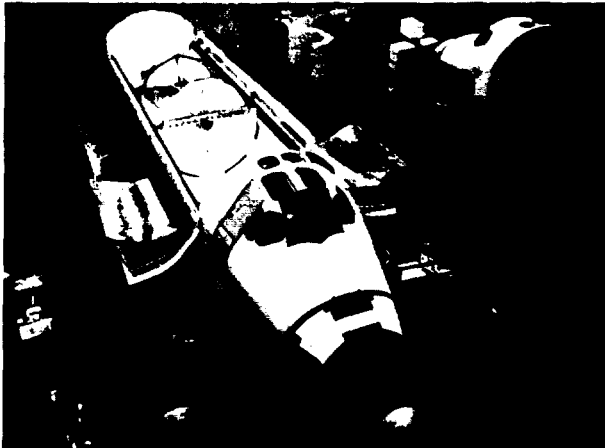

Orbiter one-g trainer

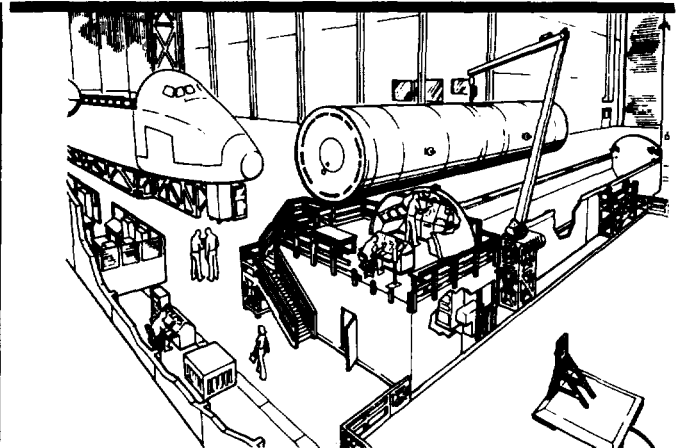

Remote manipulator system task trainer

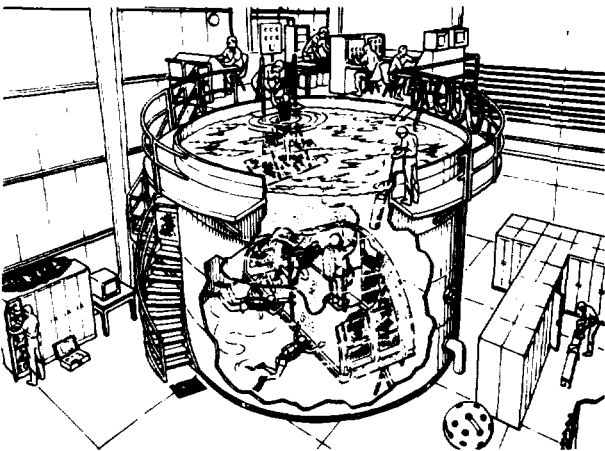

Orbiter neutral buoyancy trainer



Spacelab simulator



Shuttle mission simulator

ORIGINAL PAGE IS
OF POOR QUALITY

7. FLIGHTCREW COMPLEMENT AND CREW TRAINING

CREW COMPLEMENT

The Orbiter crew consists of the commander and the pilot. Additional crewmembers for Orbiter and payload operations are a mission specialist and one or more payload specialists (fig. 7-1). The commander and a pilot or pilot-qualified mission specialist are needed to operate and manage the Orbiter. The makeup of the rest of the crew depends on the mission requirements, complexity, and duration (table 7-1). The detailed responsibilities of the mission and payload specialists are tailored to meet the requirements of each individual flight. Crewmembers work 8-1/2-hour days.

The commander is responsible for the safety of the crew and has authority throughout the flight to deviate from the flight plan, procedures, and assignments as necessary to preserve crew safety or vehicle integrity. The commander is also responsible for the overall execution of the flight plan in compliance with NASA policy, mission rules, and Mission Control Center directives.

The pilot is second in command of the flight. The pilot assists the commander in the conduct of all phases of Orbiter flight and is given delegated responsibilities (e.g., during two-shift orbital operations). The commander or the pilot will also be available to perform specific payload operations.

The mission specialist coordinates payload operations and is responsible to the user for carrying out scientific objectives. The mission specialist will resolve conflicts between payloads and will approve flight plan changes caused by payload equipment failures. He or she may also operate experiments to which no payload specialist is assigned or may assist the payload specialist. During launch and recovery, the mission specialist monitors and controls the payload for vehicle safety.

The payload specialist manages and operates experiments or other payloads assigned to him or her and may resolve conflicts between users' payloads and approve flight plan changes caused by payload equipment failures. The payload specialist will be cross-trained as necessary to assist the mission specialist or other payload specialists in experiment operation. In some instances, the payload specialist may be responsible for all experiments onboard. He or she may operate those Orbiter and Spacelab payload support systems that are required for efficient experiment operation, such as the instrument pointing subsystem, the command and data management subsystem, and the scientific airlocks. The payload specialist will also operate certain Orbiter systems, such as the hatches and the food and hygiene systems, and will be trained in normal and emergency procedures for crew safety.

The responsibility for onorbit management of Orbiter systems and attached payload support systems and for extravehicular activity and payload manipulation with the remote manipulator system rests with the basic crew because extensive training is required for the safe and efficient operation of these systems. In general, the commander and the pilot will manage Orbiter systems and standard payload support systems, such as Spacelab and inertial upper stage (IUS) systems; the mission specialist and/or payload specialists will manage payload support systems that are mission dependent and have an extensive interface with the payload, such as the instrument pointing subsystem.

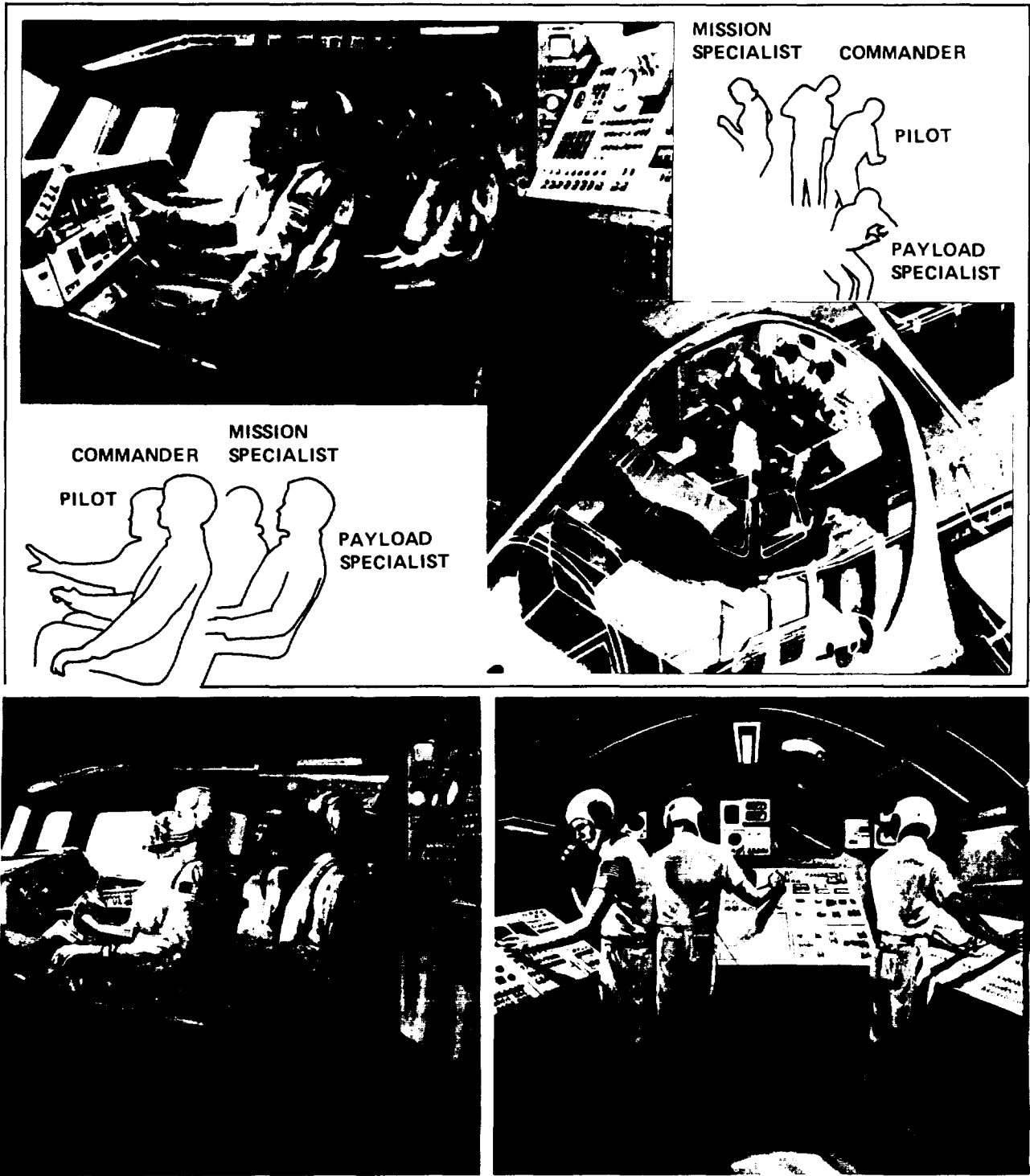

Figure 7-1.—Space Shuttle flightcrew complement.

TABLE 7-1.—FLIGHTCREW COMPLEMENT

Crewmember	Payload carrier					
	Orbiter only	Spacelab module	Spacelab pallet	IUS or SSUS ^a	Long Duration Exposure Facility	Multimission Modular Spacecraft
Commander	1	1	1	1	1	1
Pilot	1	1	1	1	1	1
Mission specialist	1	1/shift	1/shift	1	1	1
Payload specialist	0 or 1	1 to 4	0 to 3	0	0	0
Crew total	3 or 4	4 to 7	3 to 6	3	3	3

^aIUS = inertial upper stage; SSUS = spinning solid upper stage.

TRAINING FACILITIES

The training facilities for Space Shuttle crewmembers include mockups, functional trainers, mathematical models compatible with various computer complexes, and complete payload (experiment) simulators. The payload simulators emphasize the payload philosophy, operations, malfunctions, objectives, or requirements. The training facilities are located either at the NASA Lyndon B. Johnson Space Center (JSC), Houston, Texas, or at user locations.

Several crew training facilities at JSC can interface with payloads or experiments.

An Orbiter one-g trainer, a full-scale flight deck, a mid deck, and a mid body (complete with payload bay) are used for flightcrew training in habitability, extravehicular activity, ingress, egress, television operations, waste management, stowage, and routine housekeeping and maintenance.

The Orbiter neutral buoyancy trainer, designed to be used in a water immersion facility, includes a full-scale crew cabin mid deck, an airlock, and payload bay doors and provides a simulated zero-g environment for extravehicular training.

The Shuttle mission simulator (SMS) provides full-fidelity forward and aft crew stations. The SMS is computer controlled with systems mathematical models, consistent with the flight dynamics, driving the crew station displays. It will be used to provide training on combined systems and flight team operations. It includes the capability to simulate payload support systems with mathematical models, remote manipulator system dynamic operations using computer-generated imagery, and Spacelab support systems by interfacing with the Spacelab simulator. The SMS can also be interfaced with the Mission Control Center for conducting crew/ground integrated simulations.

The remote manipulator system task trainer consists of an aft crew station mockup, a payload bay mockup, and a mechanically operated arm. Payload grappling (in the payload bay), berthing, visual operations, payload bay camera operations, and manipulator software operations are simulated on the device. The user will provide helium-inflatable models to geometrically simulate the payload.

A Spacelab simulator (SLS), which consists of a core and an experiment segment interior with computer modeling of the Spacelab systems, will be used for flightcrew and ground team training. This simulator will also be used as a trainer for crew accommodations, habitability, stowage, and safety methods.

PAYLOAD SPECIALIST TRAINING

Training a payload specialist for an Orbiter-only flight requires approximately 180 hours. A flight with Spacelab pallets requires 189 hours of training and one with a Spacelab module requires 203 hours.

Two months of nearly full-time training approximates 320 hours of available time, half of which is spent in formalized classroom and trainer/simulator training. The remaining time at JSC can be allocated to Shuttle payload flight plan integration and reviews, flight/mission rules development and reviews, flight techniques meetings, and flight requirements implementation reviews. For some complex payloads (e.g., multidiscipline), the dedicated training may take more than 2 months. Payload specialists who

have flown before will take a proficiency examination and repeat any training necessary.

Flight-independent training for the payload specialist involves those crew tasks necessary for any crewmember to function effectively during flight; this training totals approximately 124 hours. Flight-dependent training can be divided into two types: payload discipline training and training necessary to support Shuttle/payload integrated operations. The second is characterized by integrated simulations involving the entire flight operations support teams. Approximately 115 hours are devoted to this type of training.

The payload specialist training may start as long as 2 years before the flight.

8. TESTING

8. TESTING

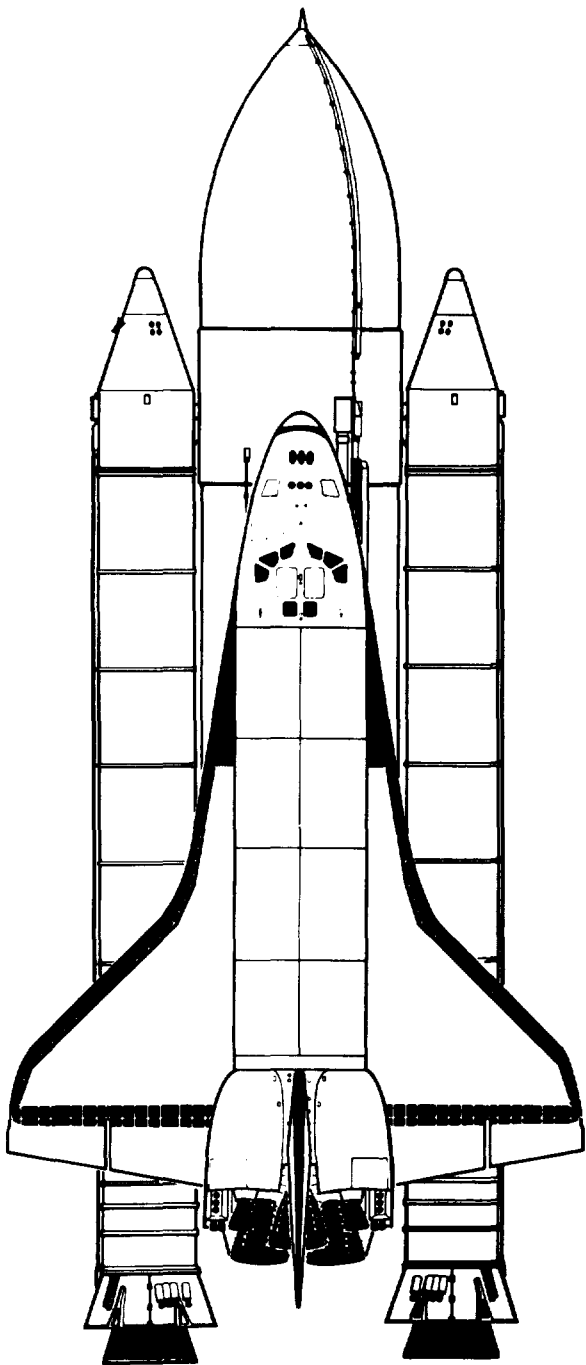

GROUND VIBRATION TESTS	8-5
Scaled Vibration Tests	8-5
Mated Vertical Ground Vibration Tests	8-5
MAIN PROPULSION SYSTEM TESTS.....	8-10
Space Shuttle Main Engine Tests.....	8-10
Solid Rocket Booster Tests	8-12
External Tank Tests.....	8-13
ELECTRONIC SYSTEMS TESTS.....	8-14
AVIONICS INTEGRATION TESTS.....	8-14
GROUND TESTS	8-15
APPROACH AND LANDING TESTS	8-16

PRECEDING PAGE BLANK NOT FILMED

Briefly...

Startled alligators in Mississippi, rumbling echoes in the mountains of Utah, and the "world's largest biplane" flying over the Mojave Desert were all part of the testing that went into getting the Orbiter ready for space flight. Individual pieces as well as full Orbiter systems were exhaustively tested in laboratories and on test stands before the go-ahead was given for the first orbital flight.

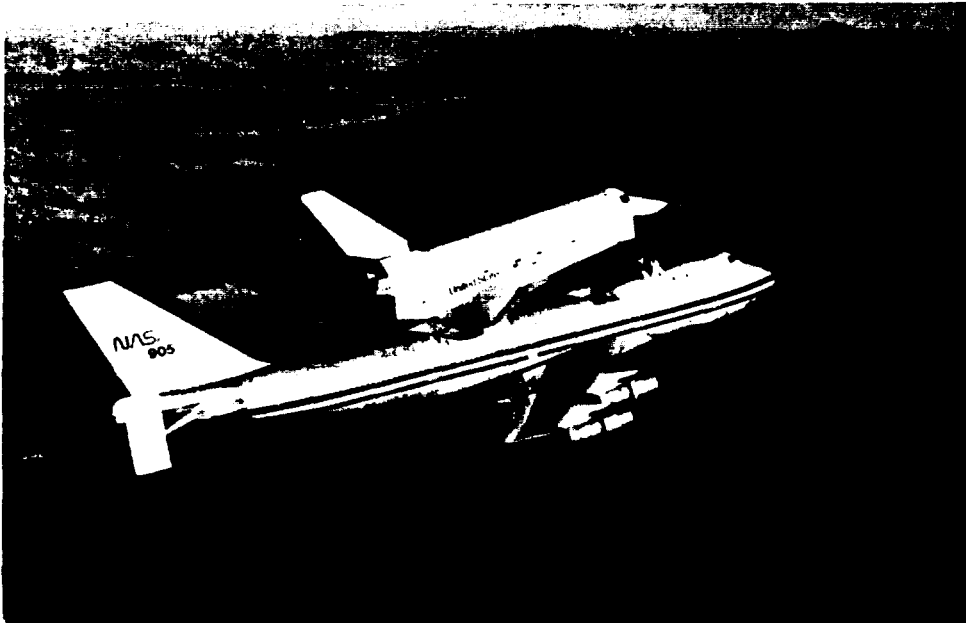

The Space Shuttle Orbiter 101 *Enterprise* atop a 747 carrier aircraft before separation for the first tailcone-off free flight of the Shuttle approach and landing test series (NASA-S-77-28961).

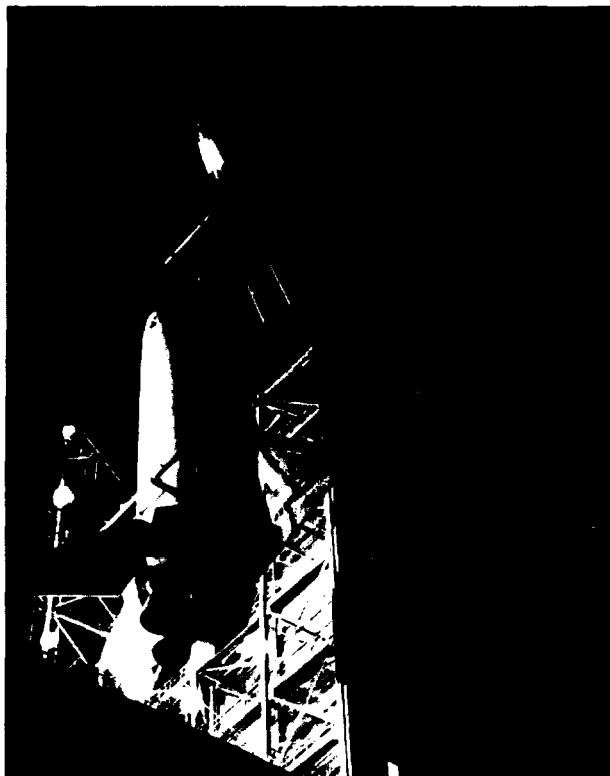

The Orbiter *Enterprise* is being hoisted into the dynamic test stand at the Marshall Space Flight Center for a series of ground vibration tests (MSFC-8-88983).

ORIGINAL PAGE IS
OF POOR QUALITY

8. TESTING

The Space Shuttle vehicle project offices conducted both ground verification and atmospheric flight tests on individual vehicle components. In addition to these single-element tests, a series of major integrated Shuttle system ground tests were conducted. These scaled and full-scale tests were designed to provide load, vibration, and thermal characteristics for orbital flight-critical design verification and integrated avionics systems hardware/software verification. The following major tests were conducted on integrated Shuttle systems/vehicles at the locations indicated.

1. Ground vibration tests
 - Quarter-scale models:
 - Rockwell International, Downey, California
 - Full-scale mated vehicle:
 - NASA Marshall Space Flight Center, Huntsville, Alabama
2. Main propulsion system tests
 - National Space Technology Laboratories, Bay St. Louis, Mississippi
3. Electronic systems tests
 - Electronic Systems Test Laboratory, NASA Johnson Space Center, Houston, Texas
4. Avionics integration tests
 - Shuttle Avionics Integration Laboratory, NASA Johnson Space Center, Houston, Texas
5. Ground tests
 - Rockwell International, Downey, California
 - NASA Marshall Space Flight Center, Huntsville, Alabama
 - NASA Kennedy Space Center, Florida

6. Approach and landing tests
 - Dryden Flight Research Center, Edwards Air Force Base, California
 - NASA Johnson Space Center, Houston, Texas
 - NASA Kennedy Space Center, Florida

GROUND VIBRATION TESTS

Scaled Vibration Tests

Vibration tests of the entire Shuttle vehicle, using one-quarter-size replicas of each element, began in mid-November 1976 and were concluded in early 1978. The quarter-scale model was constructed of the same materials as the full-scale vehicle and was designed to have representative dynamic characteristics. These tests verified the analytical vibration model developed for the Shuttle during representative flight phases.

Mated Vertical Ground Vibration Tests

The first Space Shuttle Orbiter, the "*Enterprise*," a flight-type External Tank (ET), and two Solid Rocket Boosters (SRB's) were transported to the Marshall Space Flight Center (MSFC) in Huntsville, Alabama, early in 1978 for tests to evaluate the structural dynamics and their effect on the control system of the Shuttle. The *Enterprise* arrived in March, ferried piggyback on the same Boeing 747 aircraft that had carried it aloft for early flight tests (fig. 8-1). Arriving in segments by rail from Utah, the West Coast, and other locations, the Solid Rocket Boosters were assembled at MSFC. The largest Shuttle element, the External Tank, was assembled at New Orleans and arrived by barge on the Tennessee River early in March. The complete Space Shuttle vehicle was then assembled for the first time for these ground vibration tests at MSFC. The tests were conducted in the huge facility originally constructed for testing the Saturn V launch vehicle.

The mated vertical ground vibration tests were not shaking tests to determine how strong the vehicle is. Engineers at MSFC "floated" the Orbiter in the MSFC dynamic test stand (fig. 8-2) and applied vibrations to its exterior with exciters powered by amplifiers similar to those found on home stereo sets. Sensors placed along the Orbiter skin at other locations recorded the characteristics of the vibrations as they passed

from one area to another. Data from these tests permitted verification of the system design and of the mathematical models used to predict how the Shuttle control system will react to the much more severe vibrations expected during launch and flight into orbit. The ground vibration tests continued throughout 1978 and into 1979 with pauses only to change the test configuration of the Space Shuttle vehicle.

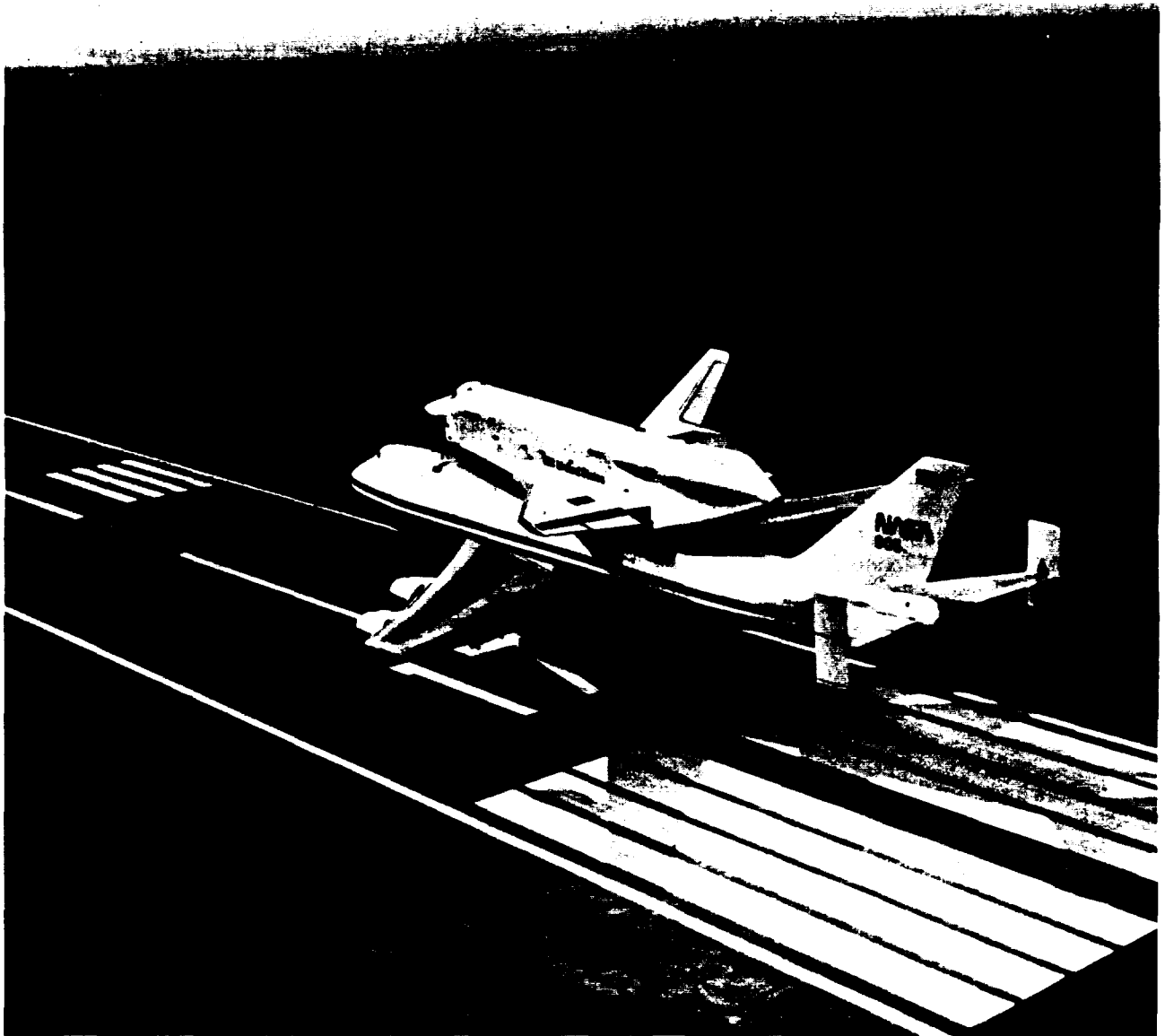

Figure 8-1.—The Orbiter Enterprise arriving at the Marshall Space Flight Center in March 1978 for ground vibration tests (MSFC 8-87817).

The first test article configuration (fig. 8-3) included the Orbiter and the External Tank and simulated the high-altitude portion of a Shuttle mission after the Solid Rocket Boosters have separated. The ET liquid oxygen tank was filled with progressively smaller quantities of deionized water to simulate use of propellant by the main engines. The liquid hydrogen tank was pressurized but empty.

For the second test configuration (fig. 8-4), Solid Rocket Boosters filled with inert propellants were stacked in the test stand together with the Orbiter and the External Tank. This configuration simulated lift-off conditions and was the first stacking of all the Space Shuttle components as they will appear for launch.

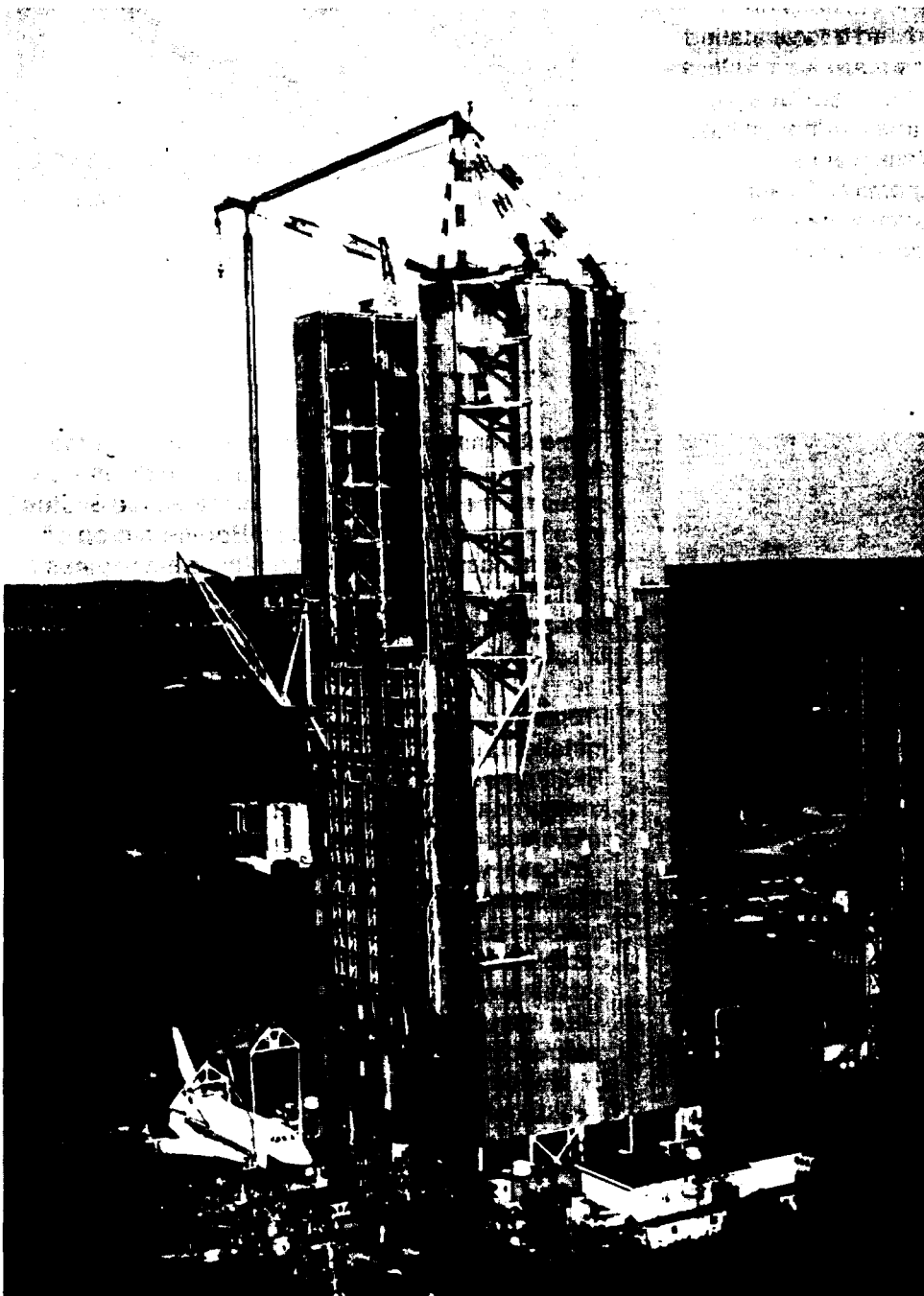

Figure 8-2.—The dynamic test stand at the Marshall Space Flight Center (MSFC 8-88984).

ORIGINAL PAGE IS
OF POOR QUALITY

The third test configuration was the same as the second except that the Solid Rocket Boosters were empty, simulating the portion of a Shuttle mission just before booster separation. Following this final test series, the Shuttle components were removed from the test stand and prepared for return to their respective points of origin.

Dynamic test suspension system.— A unique suspension system of air bags and cables was used to suspend the Orbiter *Enterprise* and the External Tank in the test tower for the first phase of the Shuttle ground tests. The suspension system included a large overhead truss installed like a crossbeam between two test-stand walls at the 66-meter (216-foot) level. The air bags and cables were attached to the truss. Although the *Enterprise* and the External Tank weigh approximately 544 000 kilograms (1.2 million pounds), this suspension system allowed the freedom of movement necessary for the acquisition of test data.



Figure 8-3.—The Orbiter *Enterprise* being lowered into place in the dynamic test stand prior to being mated with the External Tank for ground vibration testing (MSFC 8-88985).

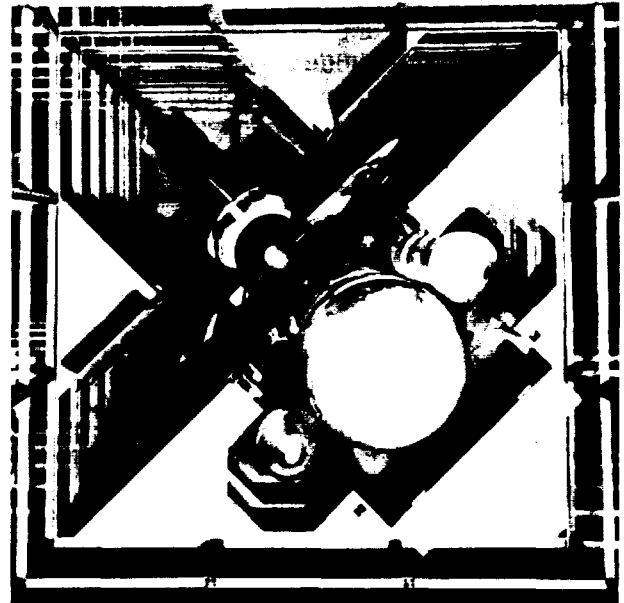

Figure 8-4.—The Orbiter *Enterprise*, the Solid Rocket Boosters, and the External Tank in the dynamic test stand, ready for mated vertical ground vibration testing (MSFC 8-84198).

The suspension of the Orbiter and the ET for the first phase of testing duplicated as nearly as possible the flight conditions of the Space Shuttle from the time the Solid Rocket Boosters drop off at 2 minutes into the flight until the main engines shut off 6 minutes later. Tests involving the entire Space Shuttle assembly used a different suspension system.

Preparation for the first test phase began with the installation of the External Tank in the test stand. The tank was temporarily affixed to the stand with knee braces. Then the *Enterprise* was lowered into place (see fig. 8-3) and mated to the External Tank as it will be for an actual flight. After the *Enterprise* was in place, engineers installed the suspension system overhead and attached the cables to the External Tank. The upper ends of the cables were attached to the air bags. The air bags were then pressurized and the knee braces removed. At this point, the *Enterprise* and the External Tank were suspended by the cables (fig. 8-5). Lateral restraints prevented sideward movement of the configuration.

The suspension system was not needed for the second and third phases of the test, which used the Solid Rocket Boosters, and was therefore removed.

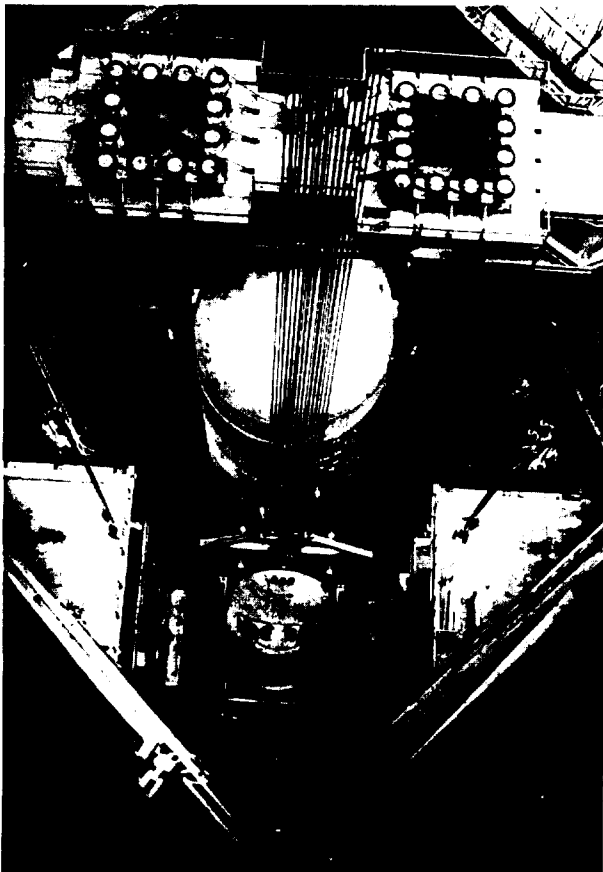

Figure 8-5.—Dynamic test stand suspension system (MSFC 8-90772).

Hydrodynamic stands.— Hydrodynamic stands that allow vertical, lateral, and rotational movement were used when the entire Space Shuttle was installed in the dynamic test stand for the second and third phases of the ground vibration tests (fig. 8-6). Four stands were used, two under each Solid Rocket Booster. Each stand contained a cylinder and a piston with bearings installed on top of each piston. Together, this hardware provided for freedom of movement of the Space Shuttle Orbiter, External Tank, and Solid Rocket Boosters. The stands supported a total weight of approximately 1.8 million kilograms (4 million pounds) when the Solid Rocket Boosters were loaded with inert propellants. When the boosters were empty, the total weight on the stands was reduced to approximately 680 000 kilograms (1.5 million pounds).

Under test conditions, the cylinders were pressurized to approximately 10 300 kN/m² (1500 psi) and charged with approximately 3785 liters (1000 gallons) of a special oil. The bearings on top of the pistons created the "floating" characteristics desired for the tests.

During the first phase of the tests, the hydrodynamic stands were not used because only the Orbiter and the External Tank were installed in the test stand. For the second test phase, the Solid Rocket Boosters, filled with inert propellants, were stacked inside the test stand on top of the hydrodynamic stands. The External Tank was then attached to the boosters and the Orbiter was mated to the External Tank. The third test phase was the same as the second except that the Solid Rocket Boosters were empty.

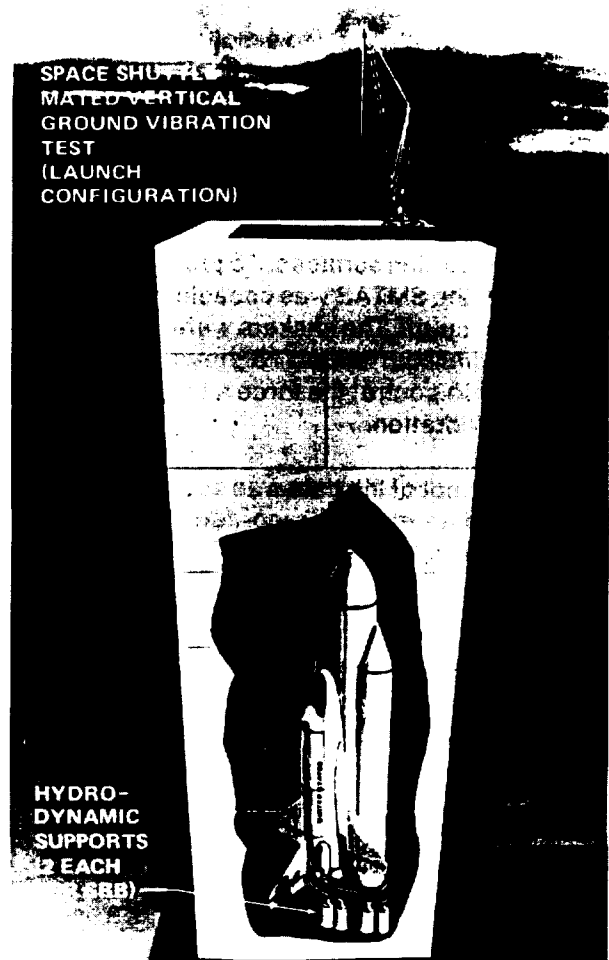

Figure 8-6.—Dynamic test stand hydrodynamic stands.

The hydrodynamic stands, originally used in the dynamic testing of the Apollo-Saturn V vehicle, were refurbished and modified for the Space Shuttle tests. Marshall Space Flight Center engineers estimate that the refurbishment and modification costs were about one-fourth the cost of a new system.

Vibration system.— The key element in the ground vibration testing was the system that applied vibrations to the Shuttle while it was positioned vertically in the 110-meter (360-foot) high dynamic test stand. Called the Shuttle modal test and analysis system (SMTAS), this system provided the required vibrational cycle and force inputs and acquired the response data from the vehicle.

The SMTAS provided automatic control of up to 24 preselected shaker channels from the available thirty-six 68-kilogram (150-pound) shakers and twenty 454-kilogram (1000-pound) shakers that were used to simultaneously apply precise excitation forces at preselected points on the Space Shuttle. The shakers were affixed to the test facility structure by soft mounts. The shaker rods extended to the Space Shuttle and were attached to it at hard points over spars, ribs, or other structural elements but not over unsupported skin surfaces. To protect the Shuttle hardware, the SMTAS was capable of manual or automatic cutoff. The shakers were electrodynamic. The SMTAS provided the drive amplifiers to control the force and the frequency or rate of vibration.

Although most of the data was acquired by the SMTAS, data were also recorded through test facility channels.

MAIN PROPULSION SYSTEM TESTS

Space Shuttle Main Engine Tests

Development activity for the Space Shuttle Main Engine (SSME) was initiated in 1972 by the Rocketdyne Division of Rockwell International under contract to the Marshall Space Flight Center. During the course of the program, 15 new engines have been built and tested, including the 3 flight engines scheduled for use on Orbiter vehicle 102, the "Columbia," which will be the first Space Shuttle launched in the nation's Space Transportation System (STS-1).

Main engine testing has been accomplished at the National Space Technology Laboratories (NSTL) near Bay St. Louis, Mississippi, on stands previously used for testing engines in the Apollo-Saturn program. Two single-engine test stands and one stand for testing the Shuttle's main propulsion system are located at the NSTL. A test stand located at the manufacturer's facility in California is used mainly for testing components of the SSME.

The initial single-engine test was conducted in May 1975 and the first static firing of the clustered engines for the main propulsion system test program occurred in April 1978.

Both the single-engine development testing and the clustered engine testing focused on exposing the engine components, the control system, and interrelated subsystems to the limiting conditions expected on the initial Shuttle flights. During this development activity, various technical problems typical of earlier engine development programs were encountered. The more significant of these problems included establishing proper turbopump bearing load sharing, developing dynamic seal durability in the rotating turbomachinery, defining turbine blade fatigue limits, eliminating fretting of piece parts in the oxygen systems, and establishing the dynamic load environment in critical engine ducts and in main injector oxidizer post elements.

An extensive certification test program was established to demonstrate that these problems were solved. Two certification engines of the flight configuration were used to complete the required 20 000 seconds of operation at conditions enveloping the specification requirements over the range of 65 to 100 percent of rated thrust levels.

In parallel to the single-engine certification tests, the three-engine-cluster main propulsion test article (MPTA) completed test objectives for integrating all major liquid propulsion elements of the Shuttle vehicle. Included in the test article were the three Space Shuttle Main Engines, the Orbiter propellant feed system, the External Tank, and other Orbiter subsystems supporting these elements.

The single-engine certification test program was divided into four test series, each involving 13 firings. These test series were completed on two engines with each engine completing two of the series. The first four firings were limited to 100 percent of rated thrust with one test in each series demonstrating 102 percent of rated thrust. A minimum of two abort mission thrust profiles was required in each series with firing duration extended to 823 seconds. Each test series required a minimum of 5000 seconds of operation.

The MPTA test objectives were to permit the main propulsion system to go through its full life cycle from 3 hours before lift-off to separation of the External Tank (however, the ET did not separate in these firings). The 12-start series of MPTA tests was conducted to certify that the main propulsion system was flightworthy for the first Shuttle flight.

The first four firings in the series were conducted with stub (short) nozzles, which permit throttling to 65 percent of rated thrust. (Flight nozzles cannot be throttled lower than 90 percent at sea level.) The next four firings were scheduled for firing with flight nozzles. However, after the 1.5-second ignition test with the flight nozzles, early cutoffs occurred following three starts. The causes of the early cutoffs included a main fuel valve rupture and a high-pressure redline in the oxygen turbine seal cavity followed by a rupture of the steerhorn after cutoff. This last failure

precipitated a delay in all testing until the steerhorns on all engines were reinforced with nickel plating.

Main propulsion testing resumed on December 17, 1979, with stub nozzles and resulted in the first full-duration test simulating actual launch and flight. The clustered engines fired successfully for 554 seconds. Testing continued with the stub nozzles through the ninth test on May 30, 1980. This test ended the stub-nozzle test series with a 578-second firing that included gimbaling and throttling in stages from 100 to 65 percent of rated thrust. The last tests of the certification series were conducted with flight nozzles on the engines. The tests were concluded in the fall of 1980.

Comparison of SSME and J-2 engine development.— The Space Shuttle Main Engine and the J-2 engine, which was developed for the Saturn launch vehicle, both use liquid oxygen and liquid hydrogen as propellants. They are both in the 890- to 2224-kilonewton (200 000- to 500 000-pound) thrust class and both provide throttling capability.

The J-2 certifications were each conducted on a new engine, with the required accumulated certification operating time ranging from 2000 to 3000 seconds. Two engines were used in the SSME program; each engine was required to accumulate 10 000 seconds.

Each of these developmental programs was structured to focus on the type of testing critical to successful development within the resources available. With the technical complexity of the SSME and with a different budget environment than that of the Saturn program, the emphasis was placed on efficient test planning and rigorous design analysis to minimize test requirements and program costs.

A comparison of engine operating time accumulated during certification tests of the SSME and the J-2 engine shows that the basic design, test planning, and overall conduct of the SSME development effort justified fewer tests than for the J-2 engine.

Shuttle
MPTA

A maturity growth comparison of the two engines indicates (1) that the first successful mission-duration SSME cluster test was achieved on the 9th test, whereas the first successful mission-duration J-2 cluster test occurred on the 16th test, and (2) that consecutive successful mission-duration tests on the J-2 engine cluster occurred only after the total program was three-fourths complete but that the SSME engine cluster achieved this milestone relatively early.

Solid Rocket Booster Tests

During the development of the solid rocket motor (SRM), the following tests were satisfactorily completed.

A hydroburst test conducted on September 30, 1977, provided the data required to verify the fracture mechanics and crack growth analyses conducted during the case design and demonstrated cyclic pressure load capability.

Four development static firings (fig. 8-7) were successfully conducted: DM-1 on July 18, 1977; DM-2 on January 18, 1978; DM-3 on October 19, 1978; and DM-4 on February 19, 1979. Three qualification static firings were also successfully conducted: QM-1 on June 13, 1979; QM-2 on

September 27, 1979; and QM-3 on February 13, 1980. These seven tests, in addition to the static article test and the mated vertical ground vibration test, provided the data required to evaluate the SRM design. The data obtained included ballistic performance; ignition system performance; case structural integrity; nozzle structural integrity; internal insulation; thrust performance; thrust reproducibility; case, nozzle, and igniter component reusability; thrust-vector-control interface; dynamic thrust vector alignment; nozzle performance; and flight readiness of the SRM.

The mated vertical ground vibration tests were successfully conducted at MSFC on lift-off and burnout configurations. Two inert loaded SRB's were used for the lift-off configuration and two empty SRB's were used for the burnout configuration.

Structural testing was successfully completed at MSFC on May 21, 1980. These tests simulated static loads on the pad (prelaunch and holddown), wind loads, flight loads, forward and aft attach loads, parachute attach loads, water impact loads, and ultimate case internal pressure.



Figure 8-7.—Developmental static firing of the solid rocket motor at the test site near Brigham City in northern Utah on February 19, 1979 (MSFC 9-94258).

External Tank Tests

Three External Tank test articles have been used in major ground test programs (fig. 8-8). Six more External Tanks are to be used for the development flight tests. These tanks are identical to the production ET configuration except for instrumentation and minor differences.

There were three major ground test programs: (1) structural strength and liquid propellant tank modal survey, (2) ground vibration, and (3) main propulsion.

Structural strength tests.— Structural strength tests were performed at MSFC to confirm structural analyses and to verify the structural design. The tests used various combinations of liquid hydrogen and liquid oxygen simulators, two intertanks, a liquid hydrogen tank, and a liquid oxygen tank. Static structural tests were performed to simulate the loads in the critical areas of prelaunch and flight sequences that establish ET design. The liquid propellant tank modal survey test was performed in addition to the static tests to determine the hydroelastic model properties of the fluid and tank structure for verification of the tank/fluid analytical model.

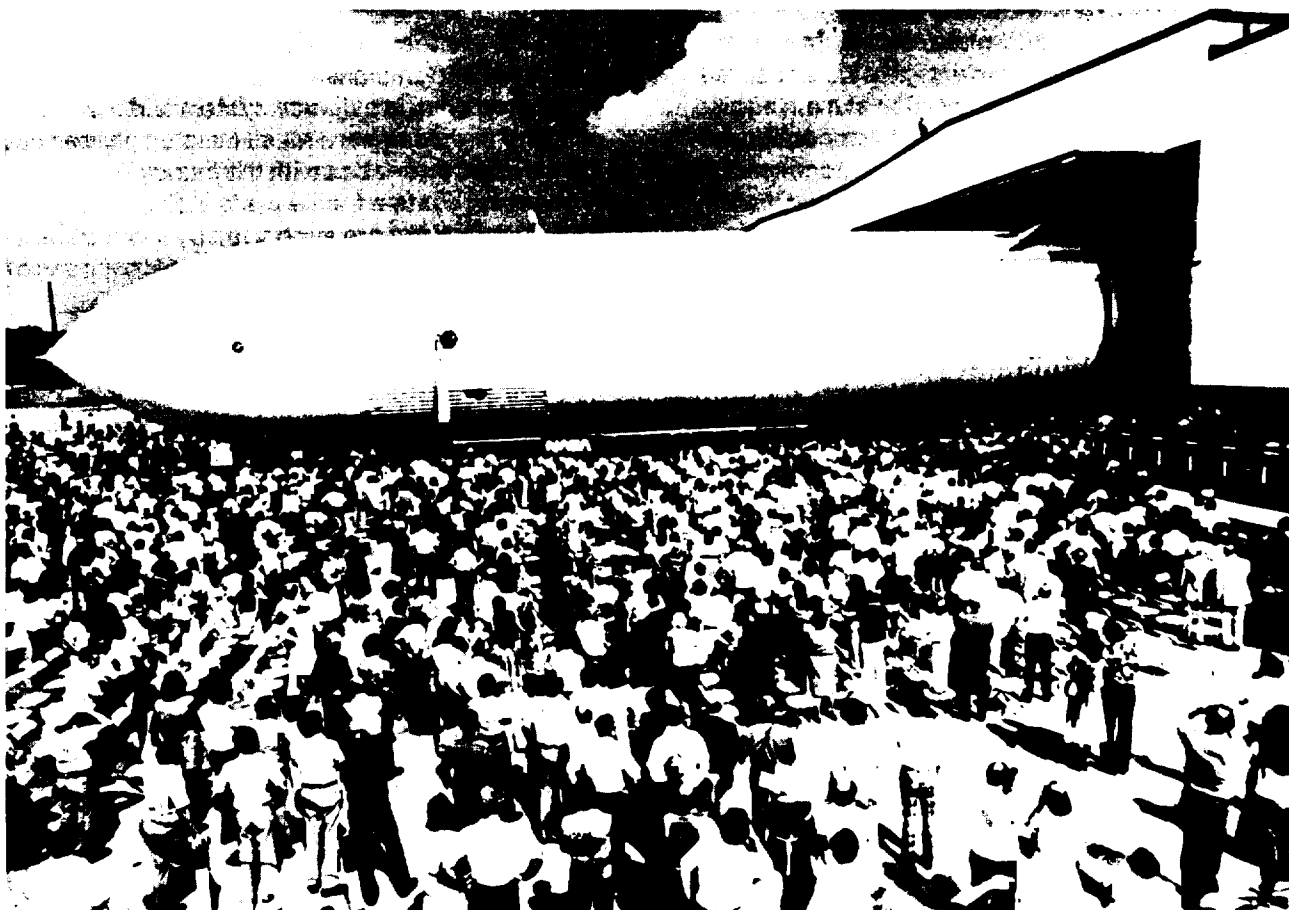

Figure 8-8.—The first Space Shuttle External Tank test article being rolled off the assembly line at the Michoud Assembly Facility in New Orleans on September 9, 1977 (MSFC 7-83349).

Ground vibration tests.— The ground vibration tests were performed in the advanced dynamic test stand at MSFC to measure the frequency, mode shapes, and damping characteristics of the mated Space Shuttle vehicle. The tests simulated five flight conditions: (1) after SRB staging at T + 125 seconds; (2) midpoint between SRB staging and burnout at T + 301 seconds; (3) SSME burnout at T + 477 seconds; (4) before SRB staging at T + 125 seconds; and (5) lift-off at T + 0 seconds. For the first three flight conditions, only the Orbiter and the External Tank were used; for the last two, the Orbiter, the Solid Rocket Boosters, and the External Tank were mated, first empty and then full.

Main propulsion tests.— The main propulsion tests were conducted to assess and verify the integrated Space Shuttle main propulsion system performance by providing full-duration firings of the Orbiter's main engines before the development flights.

In the main propulsion test article configuration, the External Tank was mated to a simulated Orbiter midbody (boilerplate) and flight-weight aft fuselage with the main engine cluster canted at 9° to simulate flight orientation at main engine shutdown. The test article was flight configured with modifications as necessary to accommodate facility-supplied auxiliary pressurization, facility safety requirements, and additional tank protection and with additional instrumentation to verify the various parameters associated with propulsion system operation. The test program called for a total of 15 static test firings with 11 being either full duration (520 seconds) or approaching full duration.

ELECTRONIC SYSTEMS TESTS

Communication links between the Orbiter and the space-flight tracking and data network through the tracking and data relay satellite system were verified by the Electronic Systems Test Laboratory at the Johnson Space Center (JSC). The system development tests in support of orbital tests began in the fall of 1977; before that, the Electronic Systems Test Laboratory supported the successful approach and landing test program.

AVIONICS INTEGRATION TESTS

The Shuttle Avionics Integration Laboratory (SAIL) is a highly specialized avionics test facility at JSC that provides a high-fidelity end-to-end operating avionics system. The SAIL consists of two test stations. The Shuttle test station consists of a multistring set of flight-qualifiable avionics equipment located in flight-type equipment bays and shelves and complete with flight-type harnesses and cable runs. The guidance, navigation, and control test station consists of a rack-mounted avionics hardware complement limited to that necessary to perform guidance, navigation, and control testing. Both stations use Shuttle flight software in conjunction with the MSFC mated elements system and a subset of the Kennedy Space Center (KSC) launch processing system. The MSFC mated elements system provides flight avionics hardware, flight software, flight wire harnesses, and sensor simulations for the External Tank, the Solid Rocket Boosters, and the Space Shuttle Main Engines.

The SAIL is a test facility that verifies the functional integrity and compatibility of the integrated Shuttle avionics system and the onboard flight software for all mission phases and the avionics interfaces with the launch processing system for the prelaunch phase. Both SAIL test stations are supported by independent vehicle flight dynamic simulation and test control facilities. Environment, aerodynamics, vehicle dynamics, sensor simulation, and scene generation are provided. A Shuttle aerosurface actuator simulator verifies the avionics hardware/software performance with the hydraulic actuators for the aerosurfaces. Similar simulations are provided for the reaction control system/orbital maneuvering system (RCS/OMS), the SSME, and the SRB thrust vector controls. A remote manipulator system simulation is to be added to the SAIL for hardware/software verification before the remote manipulator is used in flight.

GROUND TESTS

Among other ground test programs were those of the Flight Systems Laboratory and the auxiliary power unit subsystem integrated test article (APUS-ITA).

The Flight Systems Laboratory of Rockwell International Space Division is a major Orbiter ground test article used to verify that the Orbiter flight control system is ready for flight tests. Flight-type hardware is used in the hydraulic and flight control subsystems, and the plumbing, aerosurface/thrust vector control, SSME control actuators, thermal control system, and secondary structure are of high fidelity. Flight-type computers/software can control the flight control system under all vehicle control operational modes, including man-in-the-loop. The computers/software also simulate fault detection/isolation, redundancy management, and body-bending and stability gyro inputs. The main hydraulic pumps are driven with computer-controlled variable-speed motors programed to simulate the vehicle hot-gas auxiliary-power-unit (APU) speed variation as a function of pump torque.

The APUS-ITA is a full-scale auxiliary power system representative of Orbiter APU system 1. It is mounted in a test fixture that accurately simulates the upper aft (port) side of the Orbiter aft fuselage. The location of each APUS component within the ITA test fixture is identical to that of APU system 1 in the Orbiter except that the service couplings are located higher than on the Orbiter. The APUS-ITA is located in the Turbine Systems Research Laboratory at Sunstrand Advanced Technology Operations, Rockford, Illinois.

The APUS-ITA simulates the environments of the APUS while hot-firing the APU in simulated mission duty cycles. The test fixture has multi-attitude positioning so that the APU's can be tested in both launch and reentry attitudes. Thermal conditioning simulates thermal environments from 233 to 325 K (-40° to 52° C or -40° to 125° F). The high temperatures are obtained by strip heaters located on insulated panels surrounding the test structure. Low-pressure operations are simulated by evacuating the exhaust duct of the APU.

The APUS-ITA develops and certifies the APU subsystem and verifies the support equipment and the procedures for operational use in the Orbiter. It also verifies subsystem performance and all APU operating procedures, including startup, shutdown, checkout, servicing, purging, and safing.

APPROACH AND LANDING TESTS

The 9-month-long approach and landing test (ALT) program was conducted at the Dryden Flight Research Center at Edwards Air Force Base in California. The Orbiter was carried aloft by a modified 747. There were 13 flights in the ALT program. Five of these were unmanned captive flights with the inert Orbiter mated on top of the 747 Shuttle carrier aircraft (SCA). Three manned captive flights followed with an astronaut crew onboard the Orbiter operating the flight control systems while the Orbiter remained on top of the SCA. Following these eight captive flights were five "free flights" in which the astronaut crew separated the Orbiter from the SCA (fig. 8-9) and flew it back to a landing. For all eight captive flights and for the first three free flights, the Orbiter was outfitted with a tail cone covering its aft section to reduce aerodynamic drag and turbulence. The tail cone was removed for the final two free flights and the simulated engines — three main engines and two orbital maneuvering engines — were aerodynamically exposed.

The approach and landing tests began on February 15, 1977, with three taxi tests conducted to determine structural loads and responses and ground-handling and control characteristics up to flight takeoff speed. The taxi tests also validated the steering and braking of the SCA.

The manned captive-active flights exercised and evaluated all systems in the flight environment in preparation for the Orbiter free flights. These flights included flutter tests of the mated craft at low and high speeds, separation trajectory tests, and a rehearsal for the first Orbiter free flight.

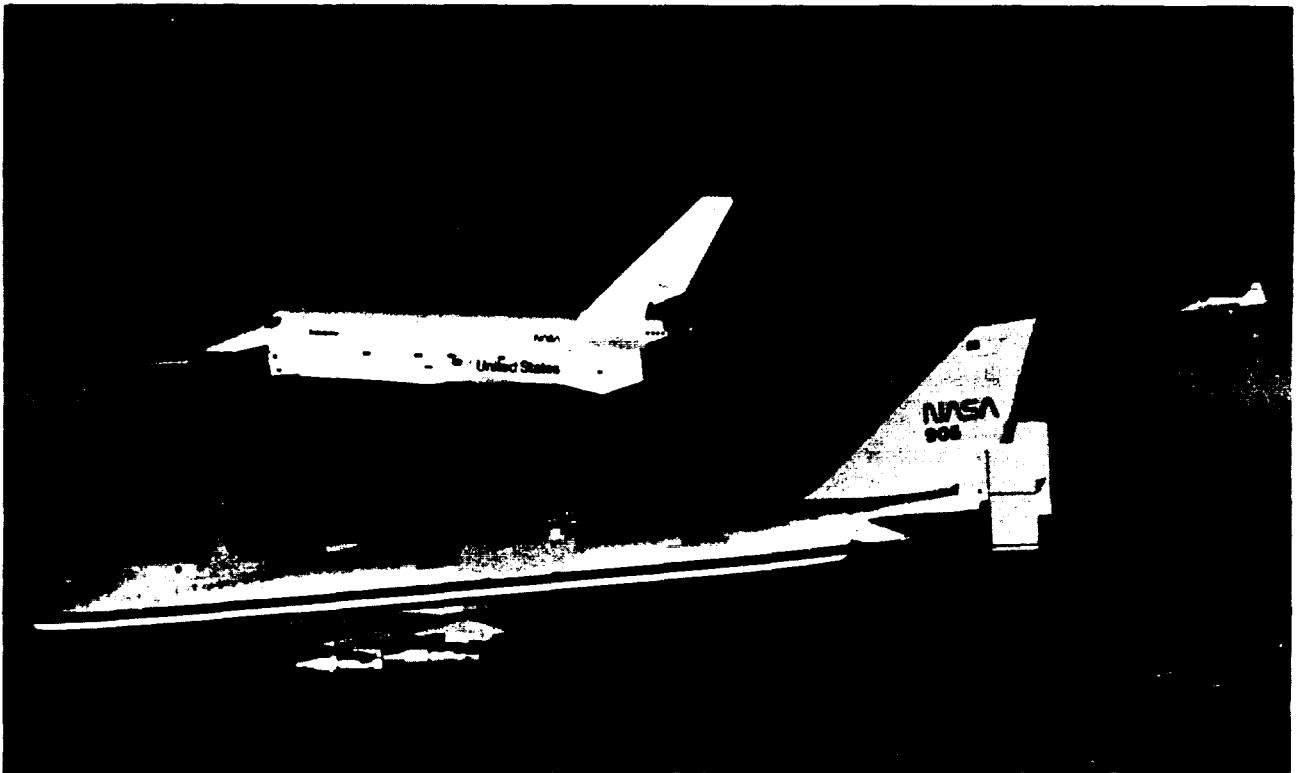

Figure 8-9.—The Orbiter being separated from the Shuttle carrier aircraft during the approach and landing tests (JSC S-77-28931).

The free flights verified the Orbiter pilot-guided approach and landing capability (fig. 8-10); demonstrated the Orbiter subsonic automatic terminal area energy management (TAEM) and automatic landing approach capability; and verified the Orbiter subsonic airworthiness, integrated system operation, and selected subsystem operation in preparation for the first manned orbital flight. The free flights also demonstrated the Orbiter's capability to safely approach and land with a minimum gross weight using several center-of-gravity configurations within the operational envelope.

The approach and landing tests were successfully completed with the fifth and final free flight of Orbiter 101 on October 22, 1977. Astronauts Fred Haise, Gordon Fullerton, Joe Engle, and Richard Truly comprised the two-man crews for these flights.

August 12, 1977, Free Flight 1 — Haise and Fullerton

September 13, 1977, Free Flight 2 — Engle and Truly

September 23, 1977, Free Flight 3 — Haise and Fullerton

October 12, 1977, Free Flight 4 — Engle and Truly

October 22, 1977, Free Flight 5 — Haise and Fullerton

The final phase of the ALT program prepared the Orbiter for four "ferry" flight tests. The fluid systems were drained and purged, the tail cone was reinstalled, and the elevon locks were installed. The forward attach strut was replaced, lowering the Orbiter's cant from 6° to 3° to reduce drag during the ferry flights. After the ferry flight tests, Orbiter 101 underwent minor modifications for the vertical ground vibration test program at MFSC.

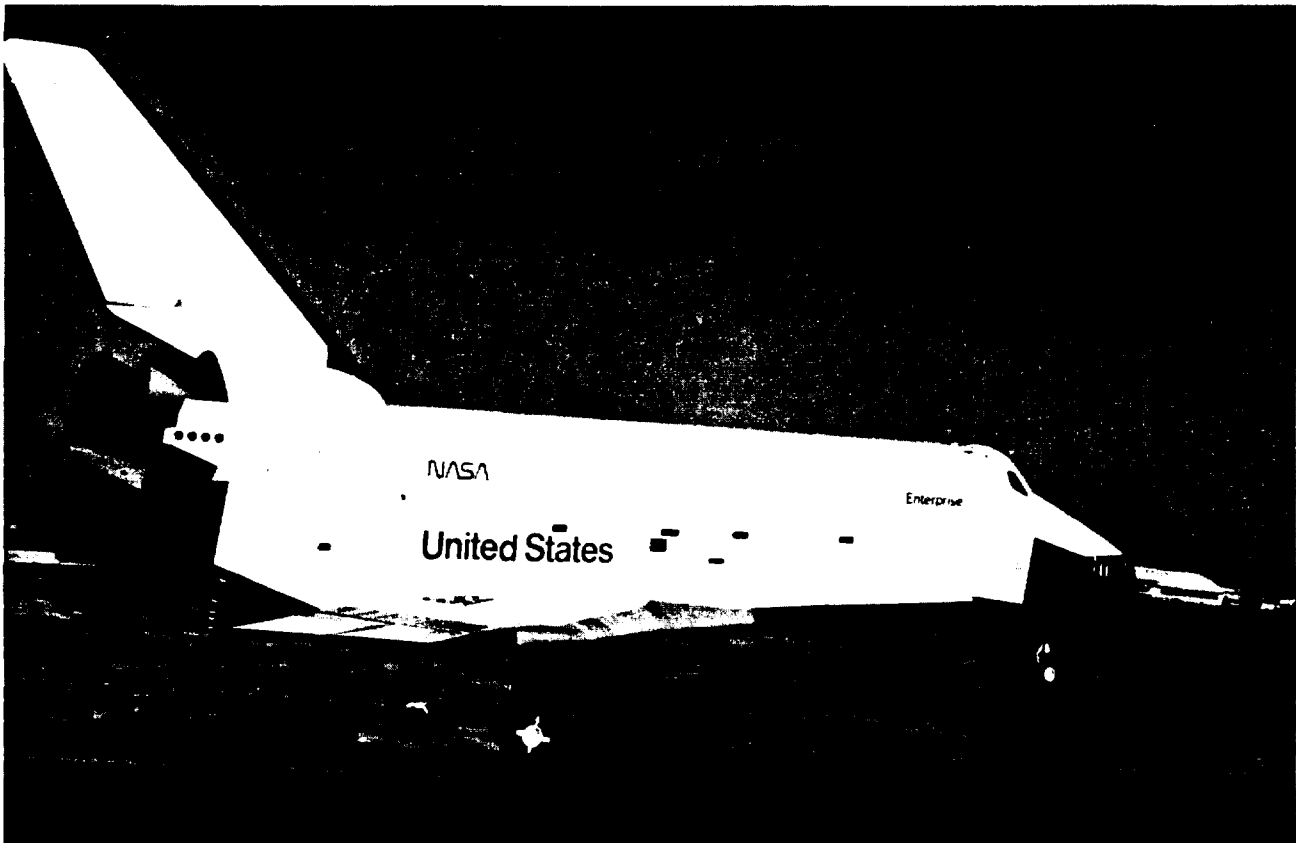
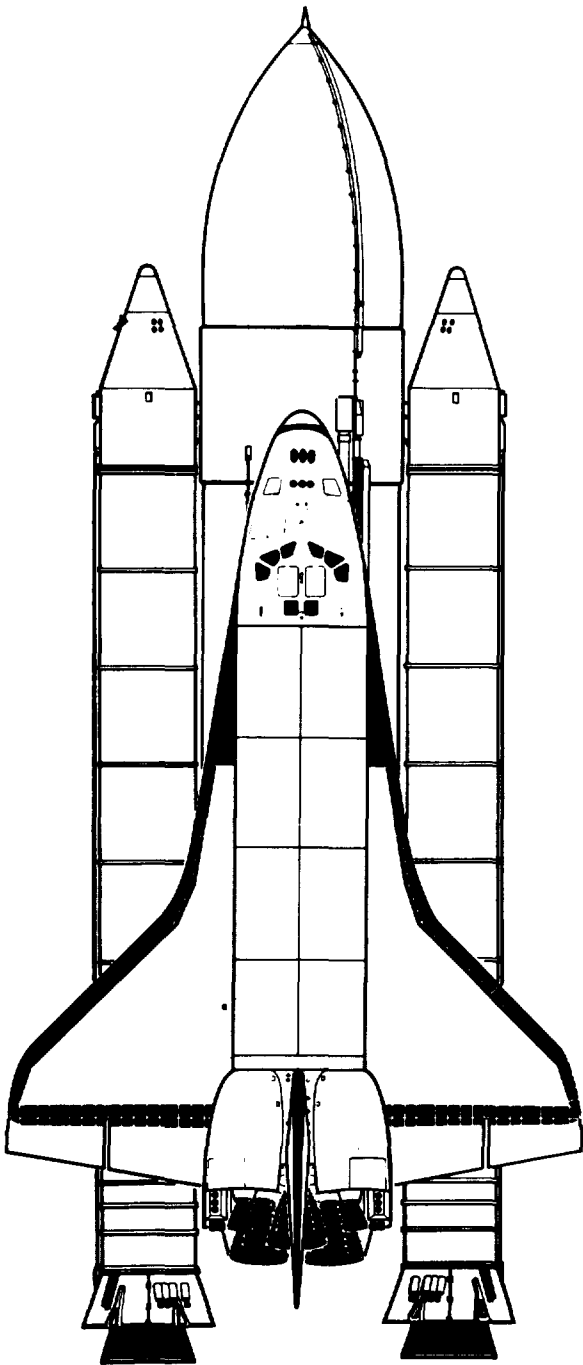

Figure 8-10.—The Orbiter coming in for a landing at the Edwards Air Force Base in California during the approach and landing tests (JSC S-77-30392).

9. MANAGEMENT

9. MANAGEMENT



FLIGHT OPERATIONS	9-5
Fundamental Guidelines	9-5
Flight Control Team	9-6
Multipurpose Support Teams	9-6
Planning and Operations Management Team	9-6
Support of Multiple Flights	9-6
PREFLIGHT PLANNING	9-7
Planning Objectives	9-7
Planning Phases	9-7
Shuttle Flight Planning	9-8
JSC MANAGEMENT	9-8

PRECEDING PAGE BLANK NOT FILMED

Briefly . . .

The Johnson Space Center has the primary responsibility for day-to-day operations of the Space Shuttle. To meet the Space Transportation System goals of low-cost operations, the flight operations have been simplified and standardized. Management of the complex Orbiter systems—formerly done by flight controllers on the ground—will now become the primary responsibility of the flightcrew.



9. MANAGEMENT

The overall direction of the Space Shuttle Program is controlled by the Office of Space Transportation Systems, which is responsible for detailed assignment of responsibilities, basic performance requirements, control of major milestones, and funding allocations to the various NASA field centers.

The Johnson Space Center (JSC) in Houston, Texas, is the lead center and thus has management responsibility for program control and overall systems engineering and systems integration. JSC is also responsible for the development, production, and delivery of the Shuttle Orbiter and manages the contract of the Orbiter manufacturer.

The Kennedy Space Center (KSC) in Florida is responsible for the design of the launch and recovery facilities. KSC will serve as the launch and landing site for the Space Shuttle development flights and for those operational missions requiring launches in an easterly direction.

The Marshall Space Flight Center (MSFC) in Huntsville, Alabama, is responsible for the development, production, and delivery of the Space Shuttle Main Engines, the Solid Rocket Boosters, and the External Tank.

FLIGHT OPERATIONS

During the past decade, three major manned space programs have been completed. Although different in goals and scope, these programs have been similar in approach and operations philosophy. Each of these programs involved costly, though essential, ground and flight operations support. To achieve the Space Shuttle

Program goals of low-cost operations, a new approach was deemed necessary.

Fundamental Guidelines

To support the high flight rates proposed for the 1980's at reasonable costs, the flight operations functions must be simplified and standardized without compromising crew safety or mission success. Guidelines for Shuttle operations have been established along the following lines.

1. The Space Shuttle is basically an autonomous vehicle and ground support will be provided only on an exception basis.
2. Standard flight packages will be developed. These packages can be used for multiple Shuttle launches and will require only a minimum amount of new trajectory data.
3. Procedures will be standardized to apply to as many types of Shuttle flights as practical. Noncritical systems failures will not be dealt with in real time.
4. Normal planning will stay well within the established performance and capabilities of the Space Transportation System (STS). This policy will avoid the intensive planning that was necessary in past programs and will keep user costs low.
5. Systems management will now be the primary responsibility of the flightcrew. Real-time ground systems support will be limited to that needed by the flight controllers to stay abreast of the mission.

In contrast to past programs, ground support will now evaluate only those failures that reduce vehicle redundancy below the level required to continue the flight. Failure analysis will be provided only for those cases involving crew safety. Planning support for upcoming flights will comprise the bulk of the ground crew work. The new Shuttle ground support will be based on three teams, the flight control team, the multipurpose support team, and the planning and operations management team.

Flight Control Team

Of the three basic elements in the new operations concept, the flight control team is the only "flight-dedicated" element. This team includes three shifts for 24-hour/day duty for the duration of each flight. This small group, headed by a flight director, will provide direct real-time support to the Orbiter crew through launch and entry and will monitor flight activities while the crew is onorbit. The flight control teams are augmented with additional specialists during launch and landing. Each flight control team will work out of a flight control room in the Mission Control Center (MCC) at JSC. Since each flight control team is dedicated to a single flight, several teams can be active in the MCC at any one time supporting simultaneous flights or simulations.

The staffing of the flight control team will be greatly reduced in comparison to that of past programs. This reduction is based on the autonomy of the Shuttle, which allows much of the systems management work to be performed by the crew.

Multipurpose Support Teams

The second element in the new operations concept, the multipurpose support teams, is one of major importance. Each of these teams will represent one support discipline and will encompass both planning and support functions. The primary job of the multipurpose support teams will be to perform operations planning for upcoming flights under the direction of the planning and operations management team. A secondary function will be to provide real-time support to the flight control teams.

Planning and Operations Management Team

The planning and operations management team is the nerve center of the Shuttle planning operations. This team consists basically of an operations management team responsible for the detailed development, scheduling, and statusing of all STS flights and programs (including those of NASA and the Department of Defense).

Support of Multiple Flights

Flight traffic model and training analyses show that three simultaneous flight operations can occur with some frequency and must be supported to maintain the STS traffic model of 50 flights each year. The MCC must therefore be capable of supporting three simultaneous flights. This includes any combination of real-time, simulation, or launch-pad support but no more than two live flights at one time. Only one simulation will be conducted at any given time and only one high-activity phase (launch or landing, either live or simulated) will be supported at a given time.

Launch monitoring and landing support.—Augmented monitoring capabilities will always be required during launch. During this critical mission phase when the crew is occupied flying the vehicle, the vehicle is in a dynamic state and unexpected changes must be detected and dealt with rapidly. As in past programs, crew safety will be the prime consideration during launch. Corrective actions will be recommended if crew safety is endangered as a result of anomalies or trajectory deviations detected by the flight control team.

Onorbit systems monitoring.—In contrast to past programs, the Orbiter crew now has the primary responsibility for routine onorbit management of onboard systems through the use of computerized systems management. One exception is the communications and data systems monitoring and management, which is performed continuously during flight by the ground crew.

Orbiter landing airfields.—The Orbiter will have ground support for safe landings from orbit in daylight or darkness and in inclement weather at two primary airfields, one at the Kennedy Space Center and the other at Vandenberg Air Force Base in California, with a secondary airfield at Edwards Air Force Base, California. In addition, a number of contingency airfields are available as needed.

Meteorological support is required at the primary airfields to provide the MCC natural environment support team with data on the following.

1. Lightning, thunderstorm, and precipitation activity in the landing area during the landing and rollout phases
2. Airfield visibility, ceiling, and cloud cover
3. Runway windspeed, wind direction, and visual range; barometric pressure; altimeter setting; temperature; and dewpoint

These data are needed at the MCC before the launch, throughout the flight, and at landing.

Prelaunch.—Shuttle prelaunch support consists of countdown participation and any special testing required due to significant changes in the flight vehicle. Normally, the flight control team will begin their prelaunch support 1 day before the countdown.

Launch.—The principal concern during powered flight operations is crew safety. During the launch phase, the flight control team functions are to predict and identify abort situations, to provide vehicle configuration recommendations, and to compute trajectory support data. As in previous space programs, launch aborts will be initiated only after all reasonable possibilities of achieving orbit are exhausted.

Onorbit operations.—During orbit, the flight control team is responsible for providing flight-related communications management, voice communications with the Orbiter, periodic systems and trajectory monitoring, data retrieval, crew activity planning support, and management of ground resources in support of payload objectives.

Reentry and landing.—Support of the reentry and landing phases of STS flights begins with vehicle reentry systems preparation and monitoring, the majority of which will be accomplished by the flightcrew. Trajectory, meteorological, and support facilities status information relative to the primary landing site will be provided to the Shuttle crew by the flight control team. If the entry situation warrants, a ground-controlled approach may be performed. Glidepath information and steering commands will be voiced to the crew.

Postlanding operations.—As the STS flight operator, JSC is responsible for the postlanding aspects, which consists of carrier aircraft operations, crew/passenger return plans, and search-and-rescue support should it be necessary.

PREFLIGHT PLANNING

Preflight planning begins up to 5 years before launch and includes all STS planning areas except payload-specific planning, which will be accomplished by the individual payload user or agent.

Planning Objectives

A simplified preflight planning concept has evolved that will encompass the following.

1. Establish a universal definition of standard flight phases, sequences, and types. This is critical to the concept of high flight rates with low support expenditures.
2. Minimize the requirements for individual analysis and complex processing but maintain the capability to handle new or nonstandard flights.
3. Standardize wherever possible the external interfaces (i.e., outside support and users), the data bases, the trajectory phases and classes, the crew activity phases, and the crew procedures and flight data file products.

Planning Phases

Preflight planning is divided into three basic categories:

Category 1 — Flights that are the most complex to plan, either because they have new content requiring end-to-end flight planning or because they inherently disallow the use of standardized planning modules

Category 2 — Flights that are less complex than Category 1 but that will require some new or individualized planning

Category 3 — Flights that are the simplest to plan in terms of manpower requirements

Shuttle Flight Planning

Space Shuttle flight planning consists of four interdependent functions: utilization planning, flight design, crew activity planning, and operations planning.

Utilization planning consists of the analysis and integration of approved payloads into acceptable payload manifests and flight schedules. During this planning activity, approved missions will be integrated into payload manifests and scheduled for flight based on priority and compatibility.

Flight design is best described as detailed trajectory, attitude, and pointing planning, which becomes part of the basic flight profile.

Crew activity planning is the analysis, development, and time-line scheduling of required activities to be performed in flight by the crew. Crew activity planners will also support payload operators. The payload operator is responsible for science planning, scheduling, and making the trade-offs necessary to accomplish his payload flight requirements. Integrated simulations involving both the crewmembers and the flight control personnel start 6 weeks before launch and continue until a few days before the lift-off.

Operations planning consists of the set of tasks that must be accomplished to ensure that the STS systems and ground flight control operations can adequately support the proposed flight. The results of detailed electrical, communications,

and environmental analyses performed during utilization planning, flight design, and crew activity planning are used as primary inputs to the operations planning phase.

JSC MANAGEMENT

The Johnson Space Center has the program management responsibility for the day-to-day operation of the Space Shuttle Program. JSC is responsible for the overall systems engineering and systems integration and also has the overall responsibility and authority for defining those elements that require government and contractor coordination. In addition, JSC is responsible for the Orbiter stage of the Shuttle.

The Johnson Space Center is responsible for the selection and training of astronauts for Space Shuttle flights and for the control and monitoring of all manned space flights. The Mission Control Center at JSC, which has controlled all manned flights since the early Gemini flights, including the Apollo, Skylab, and Apollo-Soyuz missions, will also control the STS flights. JSC also has the responsibility for the design and development of all crew equipment used on manned space flights. In addition, scientists and engineers at JSC are responsible for determining that the spacecraft systems and materials will withstand the rigors of space flight.

The directorates and program offices at JSC are responsible to the Office of Space Transportation Systems at NASA Headquarters in Washington, D.C.

10. CONTRACTORS



10. CONTRACTORS

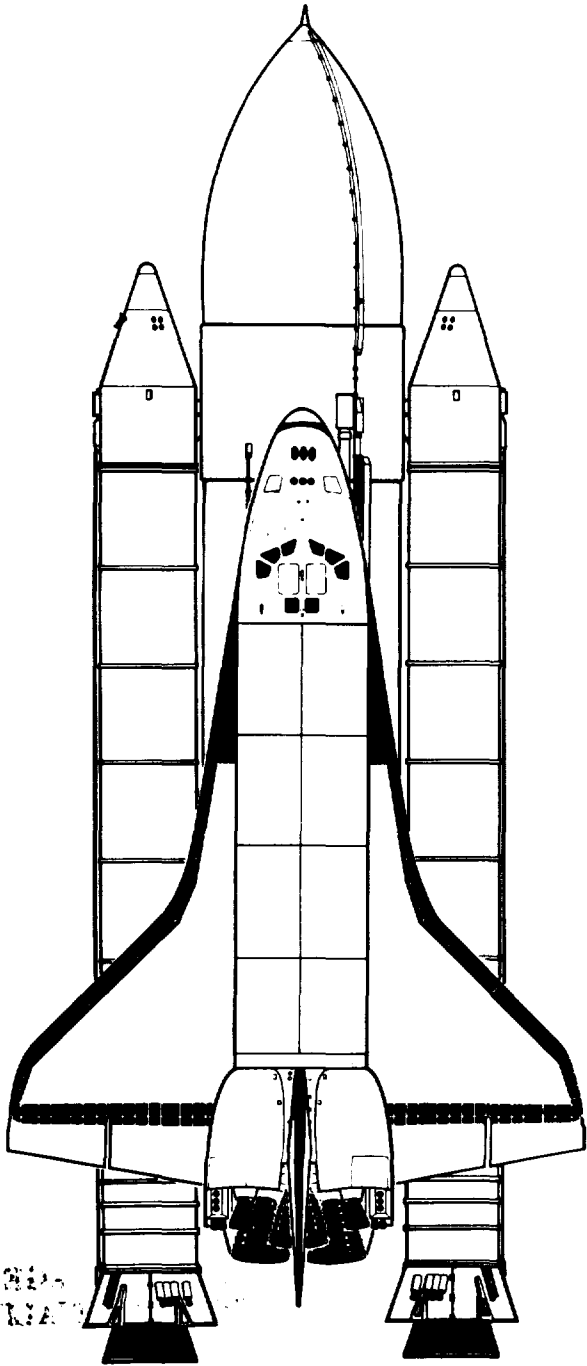

PRECEDING PAGE BLANK NOT FILMED

Briefly...

Hardware and components of the Space Transportation System are built and supplied by an aerospace industry team that reaches from coast to coast and across the Canadian border.

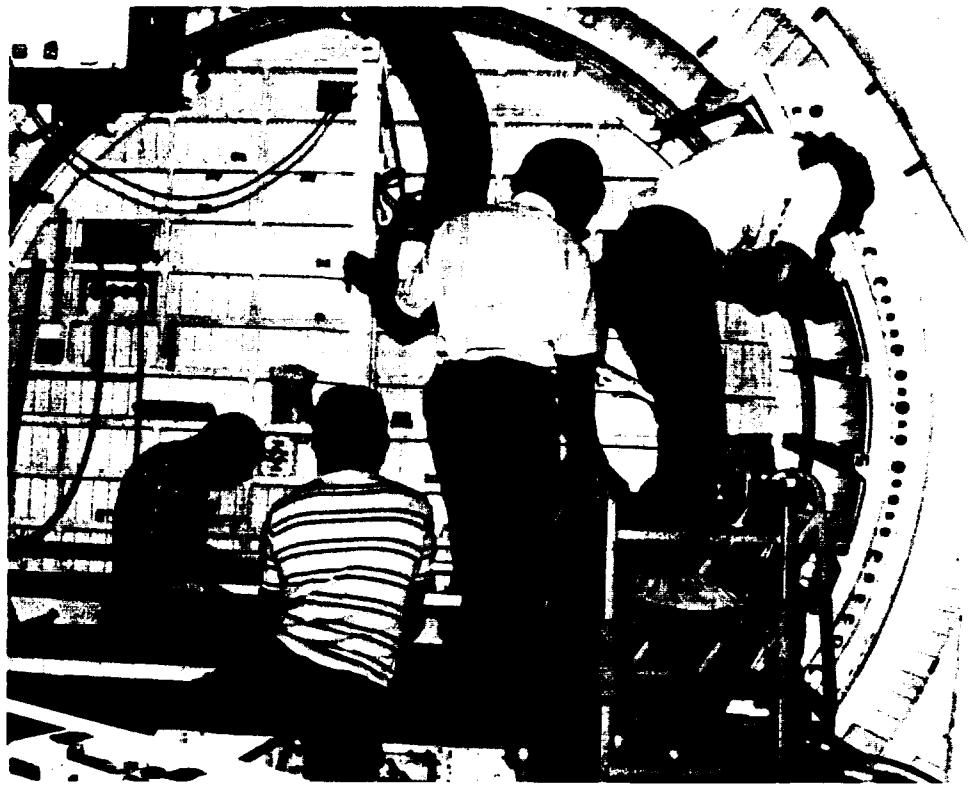

Robert Langley Space Centre

**ORIGINAL PAGE IS
OF POOR QUALITY**

10. CONTRACTORS

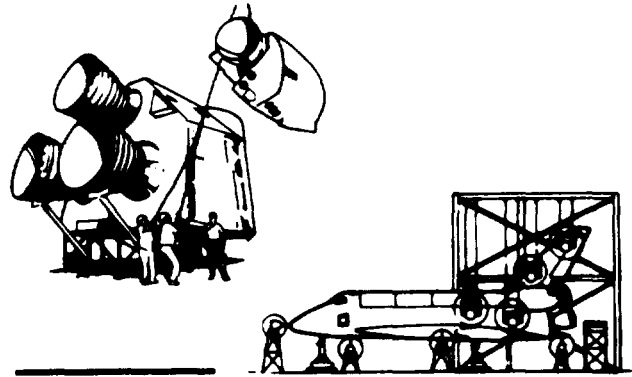

Aerojet Liquid Rocket Company
Sacramento, California 95813

AIResearch Manufacturing Company of California
Torrance, California 90509

Albany International Company
FRL
Dedham, Massachusetts 02026

Ball Aerospace Systems Division
Boulder, Colorado 80302

Beech Aircraft Corporation
Boulder, Colorado 80302

Bendix Corporation
Electrical Components Division
Sidney, New York 13838

Bendix Corporation
Navigation and Control Group
Teterboro, New Jersey 07608

The B.F. Goodrich Company
Akron, Ohio 44318

Boeing Aerospace Company
Seattle, Washington 98124

CCI Corporation
The Marquardt Company
Van Nuys, California 91409

Conrac Corporation
West Caldwell, New Jersey 07006

Coming Glass Works
Technical Products Division
Coming, New York 14830

Cutler-Hammer, Inc.
AIL Division
Farmingdale, New York 11735

Fairchild Republic Company
Farmingdale, Long Island
New York 11735

Orbiter maneuvering system engines

Air data transducer assembly and computer
Safety valve (cabin air pressure)
Solenoid valve (shutoff, air)

Nomex felt (for the thermal protection system)

Star tracker

Power reactant storage assembly

High-density connector

Airspeed altimeter
Vertical velocity indicator
Surface position indicator

Main/nose landing gear wheel and main landing gear
brake assembly

Carrier aircraft modification

Reaction control system thrusters

Engine interface unit (main propulsion system)

Windows, windshield, and side hatch window
Glass-ceramic retainers (for TPS tiles)

Microwave scanning beam landing system navigation set

Vertical tail

**General Dynamics Corporation
Convair Division
San Diego, California 92138**

**Gould, Inc.
NavCom Systems Division
El Monte, California 91731**

**Grumman Corporation
Bethpage, Long Island
New York 11714**

**Harris Corporation
Electronic Systems Division
Melbourne, Florida 32901**

**Honeywell, Inc.
Avionics Division
Minneapolis, Minnesota 55413**

**Honeywell, Inc.
Avionics Division
St. Petersburg, Florida 33733**

**Hughes Aircraft Company
Space and Communications Group
Los Angeles, California 90009**

**Hydraulic Research Textron
Valencia, California 91355**

**IBM Corporation
Federal Systems Division
Oswego, New York 13827**

**Instrument Systems Corporation
Telephonics Division
Huntington, New York 11743**

**Lear Siegler
Instrument Division
Grand Rapids, Michigan 49508**

**Lockheed-California Company
Burbank, California 91520**

**Lockheed Missiles and Space Company, Inc.
Sunnyvale, California 94088**

**Martin Marietta Corporation
New Orleans, Louisiana 70189**

**McDonnell Douglas Astronautics Company
Huntington Beach, California 92647**

**McDonnell Douglas Corporation
St. Louis, Missouri 63166**

**Menasco
Burbank, California 91510**

**Northrop Corporation
Precision Products Division
Norwood, Massachusetts 02062**

Mid fuselage

Tactical air navigation system

Wing

Pulse-code modulation master unit

Radar altimeter

Flight control system displays and controls

Ku-band radar/communication system

Servo actuator elevon-electro command hydraulics
Four-way hydraulic system flow control pressure valve

Mass memory/multifunction cathode-ray-tube display
subsystem
General-purpose computer and input-output processor

Audio distribution system (voice and tonal signals)

Attitude direction indicator

Ejection seats
Orbiter structural static and fatigue testing

High- and low-temperature reusable surface insulation

External Tank

Solid Rocket Booster structure

Aft propulsion system

Main/nose landing gear shock struts and brace assembly

Rate gyro assembly

OEA, Inc Explosive Technology Fairfield, California 94533	Pyrotechnics for crew compartment seat and seat ejection and severance and panel ejection
Rockwell International Rocketdyne Division Canoga Park, California 91304	Space Shuttle Main Engine
Rockwell International Space Systems Group Downey, California 90241	Space Shuttle Orbiter system integration
Rockwell International Tulsa Division Tulsa, Oklahoma 74151	Payload bay doors
Singer Company Kearfott Division Little Falls, New Jersey 07424	Inertial measurement unit Multiplexer interface adapter
Spar Aerospace Limited Toronto, Ontario M6B 3X8 Canada	Remote manipulator system
Sperry-Rand Corporation Flight Systems Division Phoenix, Arizona 85036	Automatic landing Multiplexer-demultiplexer
Sundstrand Corporation Rockford, Illinois 61101	Auxiliary power unit Rudder/speed brake actuation unit Actuation unit (body flap) Hydrogen recirculation pump assembly (main propulsion system)
Thiokol Corporation Wasatch Division Brigham City, Utah 84302	Solid Rocket Booster motors
TRW Electronic Systems Division Redondo Beach, California 90278	S-band payload interrogator S-band network equipment Network signal processor Payload signal processor
United Technologies Corporation Chemical Systems Division Sunnyvale, California 94088	Solid Rocket Booster separation motors Propulsion for inertial upper stage
United Technologies Corporation Hamilton Standard Division Windsor Locks, Connecticut 06096	Atmospheric revitalization subsystem/Freon coolant loop/flash evaporator system Water boiler, hydraulic thermal control unit Shuttle space suit
United Technologies Corporation Power Systems Division South Windsor, Connecticut 06074	Fuel cell power plant
United Technologies Corporation United Space Boosters, Inc. Sunnyvale, California 94088	Solid Rocket Booster assembly (checkout, launch)
Vought Corporation Dallas, Texas 75265	Leading edge structural subsystem and nose cap, reinforced carbon-carbon Payload bay door radiator and flow control assembly system

**Westinghouse Electric Corporation
Aerospace Electrical Division
Lima, Ohio 45802**

**Remote power controller
Electrical system inverters**

**Westinghouse Electric Corporation
Systems Development Division
Baltimore, Maryland 21203**

Master timing unit

APPENDIX A

Acronyms and Abbreviations

APPENDIX A

Acronyms and Abbreviations

ADI	attitude direction indicator	EPS	electrical power system
A/G	air-to-ground	ET	External Tank
ALT	approach and landing test	EVA	extravehicular activity
AMI	alpha/Mach indicator	FAA	Federal Aviation Agency
AMU	astronaut maneuvering unit	FDF	Flight Data File
APS	auxiliary propulsion system	FM	frequency-modulated
APU	auxiliary power unit	FRCS	forward reaction control system
APU/HYD	auxiliary power unit/hydraulics	FRSI	flexible reusable surface insulation
APUS	auxiliary power unit subsystem	FSS	fixed service structure
ARIA	Advanced Range Instrumentation Aircraft	GMT	Greenwich mean time
ATE	automatic test equipment	GSFC	NASA Goddard Space Flight Center
AVVI	altitude/vertical velocity indicator	GSTDN	Ground Space Tracking and Data Network
CCAFS	Cape Canaveral Air Force Station	HMF	Hypergol Maintenance and Checkout Facility (KSC)
CCMS	checkout, control, and monitor subsystem	HPU	hydraulic power unit
CDS	central data subsystem	HSI	horizontal situation indicator
CIS	Communications Interface System	HRSI	high-temperature reusable surface insulation
CITE	cargo integration test equipment	ICAO	International Civil Aviation Organization
COAS	crewman optical alinement sight	IEA	integrated electronics assembly
CPI	crosspointer indicator	IMU	inertial measurement unit
CTPB	carboxyl-terminated polybutadiene	ITA	integrated test article
C&W	caution-and-warning	IUS	inertial upper stage
DCM	displays and controls module	IVA	intravehicular activity
DCS	Display Control System	JPL	Jet Propulsion Laboratory
DOD	Department of Defense	JSC	NASA Lyndon B. Johnson Space Center
Domsat	domestic satellite	kbps	kilobits per second
DSN	Deep Space Network	KSC	NASA John F. Kennedy Space Center
DU	display unit	LCC	Launch Control Center (KSC)
ECG	electrocardiograph	LC-39	Launch Complex 39 (KSC)
ECLSS	environmental control and life support system	LCVG	liquid cooling and ventilation garment
ECU	electrical control unit	LDEF	Long-Duration Exposure Facility
EMK	Emergency Medical Kit	LED	light-emitting diode
EMU	extravehicular mobility unit	LETF	Launch Equipment Test Facility (KSC)
		LOW	left-hand overhead window
		LPS	launch processing system
		LRSI	low-temperature reusable surface insulation
		MBK	Medications and Bandage Kit
		Mbps	megabits per second
		MCC	Mission Control Center

MCC-H	Mission Control Center at Houston	SAEF	Spacecraft Assembly and Encapsulation Facility (KSC)
M/DD	mate/demate device	SAIL	Shuttle Avionics Integration Laboratory (JSC)
MDSB	mate/demate stiffleg derrick	SCA	Shuttle carrier aircraft
MET	mission-elapsed time	SCAMA	Station Conferencing and Monitoring Arrangement
MLP	Mobile Launcher Platform	SCAPE	self-contained atmospheric pressure ensemble
MMS	multimission modular spacecraft	SDPC	Shuttle Data Processing Complex
MMSE	multiuse mission support equipment	SLF	Shuttle Landing Facility (KSC)
MMU	manned maneuvering unit	SLS	Spacelab simulator
MPSR	multipurpose support room	S/M	systems management
MPST	multipurpose support team	SMS	Shuttle mission simulator
MPTA	main propulsion test article	SMTAS	Shuttle model test and analysis system
MSBLS	microwave scanning beam landing system	SOMS	Shuttle Orbiter Medical System
MSFC	NASA Marshall Space Flight Center	SPI	surface position indicator
MT	mission timer	SPIDPO	Shuttle Payload Integration and Development Program Office
NASCOM	NASA Communications Network	SRB	Solid Rocket Booster
NOCC	Network Operations Control Center (GSFC)	SRM	solid rocket motor
NSD	NASA standard detonator	SSME	Space Shuttle Main Engine
NSI	NASA standard initiator	SSUS	spinning solid upper stage
NSTL	National Space Technology Laboratories	STDN	Space Tracking and Data Network
OAA	Orbiter access arm	STS	Space Transportation System
OBS	operational bioinstrumentation system	tacan	tactical air navigation
O&C	Operations and Checkout	TAEM	terminal area energy management
OFT	Orbital Flight Test	TDRS	tracking data relay satellite
OMS	orbital maneuvering subsystem	TDRSS	Tracking and Data Relay Satellite System
OPF	Orbiter Processing Facility (KSC)	TPS	thermal protection system
PBAN	polybutadiene acrylic acid acrylonitrile terpolymer	TSM	tail service mast
PCM	pulse-code modulation	TVC	thrust vector control
PCTR	pad connection terminal room	uhf	ultra high frequency
PEAP	personal egress airpack	VAB	Vehicle Assembly Building (KSC)
PLBD	payload bay door	VAFB	Vandenberg Air Force Base
PLSS	portable life-support subsystem	VPF	Vertical Processing Facility (KSC)
PM	phase-modulated	WCS	waste collection system
POCC	Payload Operations Control Center		
PRSD	power reactant storage and distribution		
POMT	planning and operations management team		
RCC	reinforced carbon-carbon		
RCS	reaction control system		
rf	radiofrequency		
RGA	rate gyro assembly		
RHC	rotational hand controller		
RMS	remote manipulator system		
RSF	Refurbishment and Subassembly Facility (KSC)		
RSS	rotating service structure		

APPENDIX B

Glossary

APPENDIX B

Glossary

ablative material

A material, especially a coating material, designed to provide thermal protection to a body in a fluid stream through loss of mass

abort

To cut short or break off an action, operation, or procedure with a vehicle, especially because of equipment failure

acquisition

In radar, the process of locating the orbit of a satellite or the trajectory of a space probe so that tracking or telemetry data can be gathered

actuator

A servomechanism that supplies and transmits energy for the operation of other mechanisms

aerodynamic skip

An entry abort caused by atmospheric impact at an excessively shallow angle resulting in a trajectory; analogous to the skipping of a stone across the surface of a pond

airlock

A hermetically sealed chamber used for passage between modules having different pressures

angle of attack

The angle between the chord line (i.e., straight line joining the centers of curvature of the leading and trailing edges) of an airfoil and the relative airflow, normally the immediate flight path of the aircraft; also called angle of incidence

apogee motor

A propulsive device for boosting a payload from an initial parking orbit to high apogee; i.e., to geosynchronous orbit

attenuation

Reduction in intensity

attitude

The position or orientation of a vehicle, either in motion or at rest

attitude direction indicator

An instrument that displays both vehicle attitude in all three axes and compass heading

avionics

Contraction of aviation and electronics; refers to application of electronics to systems and equipment used in aeronautics and astronautics

baffle

An obstruction in a combustion chamber used to prevent combustion instability by maintaining uniform mixtures and equalizing pressures; in a fuel tank, used to prevent sloshing by damping propellant oscillation

ballistic trajectory

The path followed by a body being acted upon only by gravitational forces and by the resistance of the medium through which it passes

ball valve

A valve in which a ball regulates the aperture by its rise and fall due to fluid pressure, a spring, or its own weight

barometric switch

Any switch operated by a change in atmospheric pressure

bayonet

A means of fastening consisting of two or more pins spaced to match landed slots on the device to be attached, such as a dust cover or a camera lens; the reverse of this arrangement (pins and landed grooves) is used for mounting many automobile running lights. In each case, secure mating is achieved by twisting the object to be mounted.

bent-pipe communication

Use of relay stations to achieve non-line-of-sight transmission links

Beta

Trade name for a very fine fiberglass fabric

bit

A binary digit; hence, a unit of data in binary notation

black box

Colloquially, any unit, usually an electronic device such as an amplifier, that can be mounted or removed as a single package

blackout

A fadeout of radio and telemetry transmission between ground stations and vehicles traveling at high speeds in the atmosphere caused by signal attenuation in passing through ionized boundary-layer (plasma sheath) and shockwave regions generated by the vehicle

boilerplate model

A metal copy of a flight vehicle, the structure or components of which are heavier than the flight model

bootstrap

Referring to a self-generating or self-sustaining process

bridge crane

A crane in which a beam or bridge carries the hoisting apparatus

buffer

A storage device used to compensate for a difference in rate of flow of information or time of occurrence of events when transmitting information

bulkhead

A transverse dividing wall providing access between internal sections and sometimes designed to withstand the differential pressure required for pressurization

bungee

A spring, elastic cord, or other tension device used, for example, in an aircraft control system to balance an opposing force or in a landing gear to assist in retraction or to absorb shock

burn

Rocket engine firing

burnout

An act or instance of fuel or oxidation depletion or, ideally, the simultaneous depletion of both

bus

A main circuit, channel, or path for the transfer of electrical power or, in the case of computers, information

cathode-ray tube

A vacuum tube consisting essentially of an electron gun producing a concentrated electron beam that impinges on a phosphorescent coating on the back of a viewing screen

cavitation

The formation of bubbles in a liquid, occurring whenever the static pressure at any point in the fluid flow becomes less than the fluid vapor pressure

clevis

A fitting with a U-shaped end for attachment to the end of a pipe or rod

coldsoak

The exposure of equipment to low temperature for a long period of time to ensure that the temperature of the equipment is lowered to that of the surrounding atmosphere

critical temperature

A temperature below which a gas may be reduced to liquid form by pressure

cross-pointer

An instrument designed to detect vehicle position information with respect to a target and to display the information by means of intersecting pointers

cryogenic

Requiring or involving the use of very low temperature

cue card

An abbreviated checklist

Dacron

Trade name for a synthetic polyester textile fiber

damping

Suppression of oscillation

decoder

A device for translating electrical signals into predetermined functions

deorbit burn

A retrograde rocket engine firing by which vehicle velocity is reduced to less than that required to remain in orbit

Dewar

A double-walled flask or tank that has an evacuated space between the walls, for storing liquefied gases

diffuser

A duct, chamber, or section that decreases the velocity of a fluid and increases its pressure

dish

A parabolic reflector type of radio or radar antenna

docking

The act of joining two or more orbiting objects

Doppler effect

The change in frequency with which energy reaches a receiver when the receiver and the energy source are in motion relative to each other; also called Doppler shift

Doppler ranging

A continuous-wave trajectory-measuring system that utilizes the Doppler effect to determine the position of a moving body

drogue parachute

A small parachute used specifically to pull a larger parachute out of stowage; a small parachute used to slow down a descending aircraft or spacecraft

dynamic pressure

The pressure of a fluid resulting from its motion

elevon

A horizontal aerodynamic control surface combining the functions of an elevator and an aileron

engine bell

The conical thrust chamber enclosure, or nozzle, of a rocket engine; located behind the combustion chamber

epoxy

A polymer characterized by low shrinkage, good adhesion, mechanical and electrical strength, and chemical resistance

equivalent airspeed

Indicated, or measured, airspeed corrected for position error (angle of incidence) and air compressibility

expansion ratio

The ratio between the gas pressure in a rocket combustion chamber to the gas pressure at the nozzle outlet

fairing

Structural member designed to reduce drag or air resistance

flash evaporator

A form of flash boiler in which water is evaporated as it is pumped through by a feed pump

footprint

An area within which a spacecraft is intended to land

frangible

Readily or easily broken

Freon

Trade name used for various nonflammable gaseous and liquid fluorinated hydrocarbons used as refrigerants and as propellants for aerosols

fretting

Corrosion

front-end electronics

Avionics receiver-stage circuitry

fuel cell

A device that converts chemical energy directly into electrical energy by reacting chemicals supplied continuously

g

Symbol representing the acceleration due to gravity

gain

A general term used to denote an increase in signal power in transmission from one point to another

gantry crane

A large crane mounted on a platform that usually runs back and forth on parallel tracks astride the work area

gas generator

The high-pressure compressor/combustion/turbine section of a gas turbine that supplies a high-energy gas flow

gearbox

An encased train of gear wheels

geosynchronous orbit

An orbit in which a satellite revolves about the Earth at the same rate at which the Earth rotates on its axis. From the Earth, the satellite thus appears to be stationary over a point on the Earth

geysering

The accumulation of gaseous medium in a line and subsequent expulsion of liquid medium from the line by a bubble

gimbal

A device with two mutually perpendicular and intersecting axes of rotation, thus giving free angular movement in two directions, on which an engine or other object may be mounted; also, to move a reaction engine about on a gimbal so as to obtain pitching and yawing correction moments

gyro

Gyroscope; a device that uses the angular momentum of a spinning mass (rotor) to sense angular motion of its base about one or two axes orthogonal to the spin axis

hammerhead crane

A heavy-duty crane with a horizontal counterbalanced jib, or protecting arm

hardcopy

A written record or electrocopy of a cathode-ray-tube display

hat section

extruded, machined, or formed metal stringers for stiffening spacecraft skin

heat exchanger

A device for transferring heat from one fluid to another without inter-mixing the fluids

Herculite

Trade name for phenol-formaldehyde resin

higher order language

A computer programming language that is less

dependent on the limitations of a specific computer

hot test

A propulsion system test conducted by actually firing the propellants; also called hot firing

housekeeping

Generally used to describe routine tasks required to maintain spacecraft in habitable and operational condition during flight

hypergolic fuel (hypergol)

A rocket fuel that ignites spontaneously when in contact with an oxidizing agent

Impeller

A device that imparts motion to a fluid

Inclination

The angle between the plane of an orbit and a reference plane, usually the Equator

Inconel

Trade name for nickel-based heat-resistant alloy

integrated logic circuit

A unitized digital network operating in accordance with the rules of logic

Kapton

Trade name for a high-temperature polyimide film

Kevlar

Trade name for an epoxy glass fabric

Ku-band

A frequency band extending approximately from 15.35 to 17.25 gigahertz

latchback

A vertical-traveling, beam-mounted carriage used for restraining a swingarm service boom on the launch pad service structure

launch azimuth

The initial compass heading of a powered vehicle at launch

L-band

A frequency band extending approximately from 0.39 to 1.55 gigahertz

Lexan

Trade name for high-impact-strength, optical quality polycarbonate

light-emitting diode

Semiconductor device that radiates in the visible region; used in alphanumeric displays

limber hole

A drain hole near the bottom of a frame or other structural member

lithium hydroxide

Chemical compound used for removing carbon dioxide from a closed atmosphere

longeron

Main longitudinal member of a fuselage or nacelle

Mach number

The ratio of the speed of a body with respect to the surrounding fluid to the speed of sound in the medium

maneuver pad

Preadvisory data or information on spacecraft attitude, thrust values, event times, etc., transmitted in advance of a maneuver

mass spectrometer

An instrument for precise measurement of the atomic masses of isotopes through electrical detection of charged particles

metric data (downlink)

Telemetered systems condition information

microprogram

A program of analytic instructions constructed from the basic subcommands of a digital computer

microwave

Of, or pertaining to, radiation in that region of the radio spectrum between approximately 1 000 and 300 000 megahertz (30 centimeters to 1 millimeter wavelength)

mockup

A full-sized replica, sometimes incorporating actual functioning equipment

mode of vibration

A characteristic pattern assumed by a system undergoing vibration in which the motion of every

particle is simple harmonic with the same frequency; also called mode shape

modulation

Variation of some characteristic (e.g., amplitude, frequency, phase) of a radio wave, called the carrier wave, in accordance with instantaneous values of another wave, called the modulating wave

multiplexing

Simultaneous transmission of more than one signal through a single transmission path

Mylar

Trade name for a polyester film with high strength and extremely good transparency and electrical properties

Nomex

Trade name for a high-temperature-resistant nylon

nozzle

That part of a rocket thrust chamber assembly in which the combustion gases are accelerated to high velocity

ordnance

Pyrotechnic devices

ordnance train

A network of small explosive charges

phase lock

The technique of making the phase of an oscillator signal follow exactly the phase of a reference signal by comparing the phases of the two signals and using the resultant difference signal to adjust the frequency of the reference oscillator

pilot parachute

A small parachute used to retrieve a drogue or main parachute from stowage

pitch

An angular displacement about an axis parallel to the lateral (widthwise) axis of a vehicle

pitchover

The programmed turn from the vertical that a rocket takes as it describes an arc and points in a direction other than vertical

pogo

Term coined to describe longitudinal dynamic oscillations generated by the interaction of vehicle structural dynamics with propellant and the engine combustion process

poppet valve

A mushroom- or tulip-shaped valve commonly used for inlet and exhaust valves

potentiometer

An instrument for measuring differences in electric potential by balancing the unknown voltage against a variable known voltage; also, a variable electric resistor

preburner

A partial-combustion chamber that provides hydrogen-rich hot gases to operate the fuel and oxidizer high-pressure turbopumps

pulse-code modulation

Modulation involving a sequence of pulses so modulated as to represent information

radiofrequency

Generally, a frequency at which coherent electromagnetic radiation of energy is useful for communication purposes; specifically, above 10^4 hertz and below 3×10^{12} hertz approximately

range rate

The rate at which the distance from the measuring equipment to the target or signal source being tracked is changing with respect to time

real time

Time in which reporting on events or recording of events is simultaneous with the events

redline

Critical limit of a parameter

reefing line

A rope used to restrict the deployed area of a parachute

reticle

A system of lines, dots, crosshairs, or wires in the focus of the eyepiece of an optical instrument

rib

A fore-and-aft structural member of an airfoil used for maintaining the correct covering contour and also for stress bearing

riser

One or more straps by which a parachute harness is attached to human or hardware harness

rocket engine

A reaction engine that contains both fuel and oxidizer and that therefore can be operated in the absence of air

roll

Rotational or oscillatory movement about the longitudinal (lengthwise) axis of a vehicle

rollout

That portion of landing an aerodynamic vehicle following touchdown

S-band

A frequency band extending approximately from 1.55 to 5.2 gigahertz

servo

Control, usually by hydraulic means, of a large moment of inertia by the application of a relatively small moment of inertia

shirt-sleeve environment

Cabin atmosphere similar to that of the Earth's surface, not requiring a pressure suit

shroud line

Any one of the cords attaching a parachute's load to the canopy; also called rigging line

solenoid

Current-carrying coil consisting of one or more layers

solid-state device

A device that uses the electric, magnetic, and photic properties of solid materials

Spacelab

A portable scientific laboratory developed by the European Space Agency for performing experiments in orbit

spandex

Any of various synthetic textile elastic fibers

spar

A main spanwise member of an airfoil, or control, surface

specific impulse

A performance parameter of a rocket propellant, expressed in seconds, equal to the thrust divided by the weight flow rate

star grain

A hollow rocket-propellant grain with the cross section of the hole having a multipointed shape

state vector

Ground-generated spacecraft position, velocity, and timing information uplinked to the spacecraft computer for use as a navigational reference by the crew

station keeping

The sequence of maneuvers that maintains a vehicle in a predetermined orbit

steerhorn

A lug or boss on an engine bell to which a steering control rod is attached

stringer

A slender, lightweight, lengthwise fill-in structural member in a rocket body serving to reinforce and give shape to the skin

strongback

A heavy beam, bar, or truss structure for taking a strain

sublimation

The vaporization of a solid without the intermediate formation of a liquid

Teflon

Trade name for synthetic fluorine containing resins used especially for molding articles and for coatings to prevent sticking

telemetry

The science of measuring a quantity or quantities, transmitting the results to a distant station, and there interpreting, indicating, or recording the quantities measured; also, the data so treated

thermal conductivity

An intrinsic physical property of a substance, describing its ability to conduct heat as a consequence of molecular motion

thrust

The pushing or pulling force developed by an aircraft engine or a rocket engine

thrust vector

Direction of the thrust force

torque box

A structure built of thin walls so as to form a closed box and designed to resist torsional loads; may consist of one or more completely enclosed compartments called cells

torsion

The state of being twisted

transducer

General term for any device that converts a physical magnitude of one form of energy into another form (e.g., electrical to acoustic)

translation

Movement in a straight line without rotation

transponder

A combined receiver and transmitter whose function is to transmit signals automatically when triggered by an interrogator

trim

Adjustment of an aerodynamic vehicle's controls to achieve stability in a desired condition of flight

trunnion

A pin or pivot on which something can be rotated or tilted

truss

An assemblage of structural members (as beams) forming a rigid framework

turbine

A machine consisting principally of one or more turbine wheels (a multivaned rotor rotated by the impulse from or the reaction to a fluid passing across the vanes) and a stator (the stationary casing and blades surrounding an axial-flow compressor or a turbine wheel)

ullage

The amount that a container, such as a fuel tank, lacks of being full

ultrahigh frequency

A frequency in the range 0.3 to 3 gigahertz

umbilical

A servicing electrical or fluid line between the ground or a tower and an uprighted rocket vehicle before launch

universal hatch

D-shaped hatches in the airlock that allow the airlock to be mounted in the cabin or in the cargo bay

universal time

Time defined by the rotational motion of the Earth and determined from the apparent daily motions that reflect this rotation; also called Greenwich mean time

Velcro

Trade name for hook and pile fastener, generally of nylon, used to replace zippers in some apparel

vernier engine

A rocket engine of small thrust used primarily to obtain a fine adjustment in the velocity and trajectory or in the attitude of a rocket vehicle

vertical stabilizer

Structural component of an aerodynamic vehicle consisting of a fin and rudder assembly

wing box

A structure built of thin walls so as to form a closed box and designed to resist torsional loads; may consist of one or more completely enclosed compartments called cells; also called a torque box

wing glove

Fairing at the juncture of the wing leading edge and the fuselage

yaw

Rotational or oscillatory movement about the vertical (heighthwise) axis of a vehicle

APPENDIX C

Unit Conversion Table

APPENDIX C

Unit Conversion Table

Multiply	By	To obtain
Acceleration		
Inches per second squared	2.54	Centimeters per second squared
Area		
Acres	0.4047	Hectares
Square feet	.0929	Square meters
Square miles	259.1	Hectares
Density		
Pounds mass per cubic foot	16.02	Kilograms per cubic meter
Distance		
Feet	0.3048	Meters
Inches	2.54	Centimeters
Nautical miles	1.852	Kilometers
Statute miles	1.609	Kilometers
Energy		
Kilowatthours	3.60	Megajoules
Flow rate		
Cubic feet per minute	0.0283	Cubic meters per minute
Gallons per minute	3.7854	Liters per minute
Pounds mass per hour	.4536	Kilograms per hour
Pounds mass per minute	.4536	Kilograms per minute
Pounds mass per second	.4536	Kilograms per second
Force		
Pounds force	4.488	Newtons
Power		
British thermal units per hour	1.054	Kilojoules per hour
Brake horsepower	.7457	Kilowatts
Electric horsepower	.746	Kilowatts
Pressure		
Millimeters mercury	133.32	Newtons per square meter (pascals)
Pounds force per square inch	6.895	Kilonewtons per square meter (kilopascals)
Temperature		
Degrees Fahrenheit plus 459.67	5/9	Kelvin
Degrees Celsius plus 273.15	1	Kelvin
Velocity		
Feet per second	0.3048	Meters per second
Inches per second	2.54	Centimeters per second
Knots	1.852	Kilometers per hour
Miles per hour	1.609	Kilometers per hour
Volume		
Cubic feet	0.0283	Cubic meters
Fluid ounces	.0296	Liters
Gallons	3.7854	Liters
Weight		
Ounces	28.350	Grams
Pounds	.4536	Kilograms
Tons	.9072	Metric tons (tonnes)

2