

C74 70539

(NASA-TM-X-62214) EXPERIMENTAL
INVESTIGATION OF A LONG RANGE $M = 0.95$
ADVANCED TECHNOLOGY TRANSPORT DESIGN WITH
FOUR WING-MOUNTED ENGINES (NASA) 244 p

N81-70012

00/05 Unclas
26917

**NASA TECHNICAL
MEMORANDUM**

NASA TM X-62,214

NASA TM X-62,214

EXPERIMENTAL INVESTIGATION OF A LONG RANGE, $M = 0.95$
ADVANCED TECHNOLOGY TRANSPORT DESIGN WITH FOUR
WING-MOUNTED ENGINES

By Harry D. Radcliff and Charles R. Castellano

Ames Research Center
Moffett Field, California 94035

May 1973

REPRODUCED BY
NATIONAL TECHNICAL
INFORMATION SERVICE
U.S. DEPARTMENT OF COMMERCE
SPRINGFIELD, VA 22161

CLASSIFIED BY [REDACTED] ON [REDACTED] IN [REDACTED]
SUBJECT TO GENERAL DECLASSIFICATION SCHEDULE OF EXECUTIVE
ORDER 11652. AUTOMATICALLY DOWNGRADED AT TWO YEAR
INTERVALS AND DECLASSIFIED ON DECEMBER 31, 1979

NATIONAL SECURITY INFORMATION

Unauthorized Disclosure
Subject to Criminal Sanctions

[REDACTED] TITLE UNCLASSIFIED

274

[REDACTED]

CONTENTS

	Page
SUMMARY	1
INTRODUCTION	1
NOMENCLATURE	2
TEST FACILITY	5
MODEL DESCRIPTION	6
TESTING AND PROCEDURE	6
DATA REDUCTION	7
RESULTS AND DISCUSSION	8
CONCLUDING REMARKS	9
TABLES	
1. MODEL DIMENSIONAL DATA	10
2. WING PRESSURE ORIFICE LOCATIONS	12
3. INDEX OF DATA FIGURES	14
FIGURES	
1. AXIS SYSTEMS	16
2. MODEL DETAILS	17
3. MODEL PHOTOGRAPHS	27
4. DATA	29

1

[REDACTED]

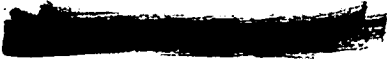

(THIS PAGE INTENTIONALLY LEFT BLANK)

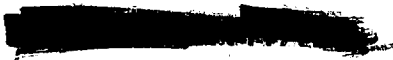



EXPERIMENTAL INVESTIGATION OF A LONG RANGE, $M = 0.95$

ADVANCED TECHNOLOGY TRANSPORT DESIGN

WITH FOUR WING-MOUNTED ENGINES

By Harry D. Radcliff and Charles R. Castellano

Ames Research Center

SUMMARY

A wind tunnel investigation was made in the Ames 11- by 11-Foot Transonic Wind Tunnel of a 0.02-scale model of a large, long range four engine transport designed to cruise at Mach 0.95. The test Mach numbers ranged from 0.50 to 0.98. Angle of attack was varied from -1 to $+10$ degrees, and angle of sideslip from -6 to $+8$ degrees. Horizontal tail incidences of 0, -1 , -3 , and -5 degrees were tested. Spoilers were tested at deflection angles of -10 and -25 degrees. Basic longitudinal and lateral-directional aerodynamic characteristics are presented. Wing pressure distributions are presented for the basic wing-body, the full configuration, and for the deflected spoilers.

INTRODUCTION

The NASA Advanced Technology Transport (ATT) systems study was conducted to evaluate the potential application of the most recent technological advances to the next generation of subsonic transport aircraft. As a part of this study the Lockheed Georgia Company was directed to study an advanced transport which carries 400 passengers, has a range of 5500 nautical miles, and cruises at Mach 0.95. Parametric studies were performed to determine the size and shape of the configuration. The resulting configuration has been designated as ATT-95.

The geometry of the ATT-95 is considerably different from other ATT-type configurations being tested. Furthermore, tests of these other configurations have not investigated the impact of configuration details such as flap-track fairings, fuselage canopy shape, wheel wells, etc., on aircraft performance. In order to further optimize the ATT-95 design and to determine the effects of practical configuration details, high subsonic speed wind tunnel tests were conducted. Experimental aerodynamic characteristics of various model configurations over a range of test conditions are presented herein with a minimum of analysis.

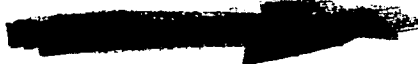

NOMENCLATURE

The axis systems and sign conventions are shown in figure 1. Owing to the limitations of the computer notation system in plotting the data, conventional aerodynamic symbols have been replaced by plot symbols in the data figures as noted below.

<u>Symbol</u>	<u>Plot Symbol</u>	<u>Definition</u>
A_D		base area
b	BREF	wing span
c		chord
\bar{c}	LREF	mean aerodynamic chord
C_A	CA	axial-force coefficient, axial force/ qS_w
C_{A_b}	CAB	base axial-force coefficient (equation 1)
C_{A_f}	CAF	forebody axial-force coefficient = $C_A' - C_{A_b}$
C_{A_i}		nacelle internal drag coefficient
C_D	CD	drag coefficient, drag/ qS_w
C_{D_b}		base drag coefficient (equation 2)
C_{D_c}	CDC	cruise drag coefficient ($C_D @ C_L = 0.47$)
C_{D_f}	CDF	forebody drag coefficient = $C_D - C_{D_b}$
C_L	CL	lift coefficient, lift/ qS_w
C_{L_α}	CLALF	lift curve slope

$C_{L\alpha_0}$	CLALFO	lift curve slope at $\alpha = 0$
$C_{L\delta_H}$	DCL/DH	lift due to horizontal tail deflection
$C_{L\delta_{SL}}$	DCL/DS	lift due to spoiler deflection
C_l	CSL	rolling-moment coefficient, rolling moment/ $qS_w b$
$C_{l\beta}$	DCSLDB	rolling-moment coefficient slope
$C_{l\delta_{SL}}$	DCSLDS	rolling moment due to spoiler deflection
C_m	CIM	pitching-moment coefficient, pitching moment/ $qS_w \bar{c}$
C_{m_0}	CIMCLO	pitching moment at $C_L = 0$
$C_{m\delta_H}$	DCLMDH	pitching moment due to horizontal tail deflection
$C_{m\delta_{SL}}$	DCLMDS	pitching moment due to spoiler deflection
$\left. \frac{\partial C_m}{\partial C_L} \right _{\alpha=0}$	DCMCLO	slope of pitching moment vs. lift coefficient curve at $\alpha = 0$
C_N	CN	normal-force coefficient, normal force/ qS_w
C_n	CLN	yawing-moment coefficient, yawing moment/ $qS_w b$
$C_{n\beta}$	DCLNDB	yawing-moment coefficient slope
$C_{n\delta_{SL}}$	DCLNDS	yawing moment due to spoiler deflection
C_p	CP	pressure coefficient, $(p - p_\infty)/q$

C_Y	CY	side-force coefficient, side force/ qS_w
$C_{Y\beta}$	DCY/DB	side-force coefficient slope
$C_{Y\delta_{SL}}$	DCY/DS	side-force due to spoiler deflection
L/D	L/D	lift-drag ratio
$(L/D)_{max}$	L/DMAX	maximum lift-drag ratio
M	MACH	free-stream Mach number
	PCTCRD	percent local chord
P_c		model base cavity pressure
P_∞		free-stream static pressure
q		free-stream dynamic pressure
Rn/ft	RN/L	unit Reynolds number, million per foot
S_w	SREF	reference wing area
	TRANS	wing transition grit locations; 0 = transition free, 1 = subcritical transition location, 2 = supercritical transition location
α	ALPHA	angle of attack
β	BETA	angle of sideslip
$\Delta\beta$	DBETA	incremental angle of sideslip
δH	HORIZIT	horizontal tail deflection
δ_{SL}	SPLR-L	left spoiler deflection
ϵ		nacelle centerline cant
η		fraction of semispan
λ		taper ratio, tip chord/root chord
Λ		sweep angle
ϕ	PHI	roll angle
σ		nacelle centerline toeout

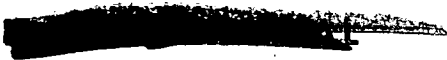

Configuration Code

B ¹	B1	fuselage
w ¹	W1	wing
N ¹	N1	inboard nacelle
N ²	N2	outboard nacelle
K ¹	K1	inboard pylon
K ²	K2	outboard pylon
V ¹	V1	vertical tail
H ¹	H1	horizontal tail
b ¹	B1	empennage bullet (integral part of V ¹)
Z ^{w1}		wing fillet (integral part of B ¹)
s ¹	S1	wing spoilers, 2 panels left side
Z ^f	SF	wing flap track fairings

TEST FACILITY

The tests were conducted in the Ames 11- by 11-Foot Transonic Wind Tunnel. This tunnel is a variable density, continuous flow type with an adjustable nozzle (two flexible walls) and a slotted test section (four walls) to permit transonic testing over a Mach number range continuously variable from 0.4 to 1.4.



MODEL DESCRIPTION

The model used in this investigation was an 0.020-scale model of the Lockheed ATT-95 airplane design. Model details and the cross-sectional area distribution of the model are shown in figure 2. Model dimensional data are presented in table 1.

The maximum diameter and length of the fuselage were 6.34 inches and 55.17 inches respectively. The aft 10 inches of fuselage contours were extensively modified to accommodate the sting support.

The nose section of the fuselage housed a support for a gang of 3 scanning pressure transducers which were connected to 114 wing pressure orifices. These orifices were located at four spanwise stations on the upper and lower surfaces of the left wing as shown in table 2.

The vertical and horizontal tails had straight line surface elements and were of the supercritical airfoil type. No provisions were made for rudder or elevator deflection. Horizontal tail incidence could be set at 0, ± 1 , ± 2 , ± 3 , -4 , and -5 degrees.

Four swept-inlet nacelles and pylons were mounted at wing stations $\eta = 0.4$ and 0.7 .

TESTING AND PROCEDURE

The model was sting mounted as shown in figure 2(b). Force and moment data were obtained from an internally mounted six-component strain gage balance over a Mach number range of 0.50 to 0.98 at a free-stream Reynolds number per foot of 4.0×10^6 . Angle of attack was varied from -1 to $+10$ degrees and angle of sideslip was varied from -6 to $+8$ degrees. Wing pressure distributions were measured for representative Mach numbers and angles of attack.

Boundary layer transition was fixed on all model components using strips of glass beads sized and located as shown in figure 2(j). The upper surface forward location (TRANS=1) was used for both subcritical and supercritical Mach numbers while the upper surface aft location (TRANS=2) was used only on two configurations and only at supercritical Mach numbers.

Luminescent oil flow visualization studies of both upper and lower wing surfaces were made. Free transition locations and transition strip effectiveness were determined using a sublimation technique.

[REDACTED]

DATA REDUCTION

Forces and moments were reduced to standard coefficient form in both the body and stability axis systems using the basic reference dimensions of:

wing area, S_w	1.8979 ft ²
mean aerodynamic chord, \bar{c}	6.3853 in
wing span, b	45.695 in

The moment reference center was located at 38.21 percent of the mean aerodynamic chord in the plane of symmetry.

The data were adjusted to the conditions of free-stream static pressure acting within the fuselage cavity and over the model fuselage base and no momentum or pressure losses (i.e., internal drag) in the four nacelle ducts. The fuselage cavity pressure was used to determine the base pressure corrections using the following relations:

$$C_{A_b} = -A_b \frac{p_c - p_\infty}{qS_w} \quad (1)$$

$$C_{D_b} = C_{A_b} \cos \alpha \quad (2)$$

The nacelle internal drag corrections were assumed to correspond to friction losses in a straight duct and are listed below.

Rn/ft	4.0×10^6
C_{A_i} (per nacelle)	0.00031
C_{A_i} (total of 4 nacelles)	0.00125

Wing pressure data were reduced to standard coefficient form, C_p .

The model angle of attack was referenced to the wing reference chord plane which was along a waterline. The measured angle of attack has been corrected for model support sting and balance deflections and tunnel air-flow angularity. The latter correction was determined from tests of the model upright and inverted.

RESULTS AND DISCUSSION

A complete index of data figures is given in table 3. Figures 4 through 13 contain plots of the basic aerodynamic coefficients. Figures 14 through 18 are summary plots of the coefficients presented as a function of Mach number. Wing pressure distributions are presented in figures 19 through 26.

Results of the test include the drag characteristics of the wing-body and the wing mounted pylon/nacelles. Interference drag for the four pylon/nacelles was small over the Mach number range indicating the feasibility of using wing mounted engines on a high subsonic transport without upsetting the favorable drag-rise characteristics of the supercritical type airfoil.

The configuration design and sizing was based on a Mach number of 0.93 as it was felt that this increment (from 0.93 to 0.95) was consistent with improvements to the drag divergence Mach number normally possible through wind tunnel optimization programs. Drag divergence Mach number is defined as the free stream Mach number for which $\partial C_D / \partial M = 0.1$. Test results indicate a drag divergence Mach number of 0.925 which is in excellent agreement with that predicted for the configuration.

A secondary, forward wing shock system was observed with the aid of luminescent oil flow visualization studies. This shock extended from the wing body junction near the wing leading edge to about 60% span where it intersected the primary (rearward) wing shock. As it was believed that the secondary shock was the result of insufficient lift compensation (local body area rule), a modification was made to the B^1 fuselage which was designated as B^3 . As the modification was made during the test, and decreasing the body area in question was impractical, fill material was added (see figure 2(i)) in hopes of obtaining the reverse effect of moving the shock even farther forward and strengthening it. Force and pressure data, figures 13 and 25, indicate that this indeed was the result. Furthermore, the pressure data show the extensive span-wise effect of the local body area ruling.

Drag increments associated with the vertical and horizontal tails were very close to the calculated skin friction increments and contributed very little to the drag rise with Mach number. Cruise trim drag was essentially zero and horizontal tail effectiveness was maintained over the Mach number and angle of attack ranges tested.

Effects of spoiler deflection (left wing only) on longitudinal and lateral aerodynamics are shown in figures 10 and 11 respectively. Spoiler effectiveness remained relatively constant to an angle of attack of 6

[REDACTED]

degrees at $M = 0.8$, and to about 4 degrees at $M = 0.95$. Pitch and roll control was maintained to the highest angle tested (10 degrees). Figure 21 shows the effects of spoiler deflection on the upper surface wing pressure distributions.

CONCLUDING REMARKS

From a wind tunnel investigation of a large, long range ATT aircraft configuration it is concluded that:

1. Satisfactory drag-rise characteristics have been demonstrated on a configuration including fuselage canopy, flap-track fairings, and four wing-mounted engines.
2. Drag-rise characteristics of the wing-body combination may be improved by proper optimization of the local body area ruling.
3. The configuration exhibited adequate longitudinal and lateral-directional stability over the Mach number and attitude ranges tested.
4. Horizontal tail effectiveness was maintained over the range of conditions tested.
5. Spoiler control was constant up to at least 4 degrees angle of attack over the range of Mach numbers tested.

Ames Research Center
National Aeronautics and Space Administration
Moffett Field, Calif., 94035

May 11, 1973

TABLE 1. - MODEL DIMENSIONAL DATA

Fuselage B¹

Length	55.17 in
Maximum diameter	6.34 in
Maximum frontal area	25.625 in ²
Fuselage reference line	W.L. 1.660
Nose location	F.S. 8.753

Wing W¹ (basic panel)

Planform area, S _w	1.8979 ft ²
Span, b	45.695 in
Mean aerodynamic chord length, \bar{c}	6.3853 in
Location of 0.25 M.A.C.	F.S. 38.2426
	W.L. 0.5045
	B.L. 9.7088
Aspect ratio	7.640
Taper ratio, λ	0.379
Dihedral (50% chord), $\eta = 0.130$ to $\eta = 0.186$	2.0°
Dihedral (50% chord), $\eta = 0.186$ to $\eta = 1.0$	5.0°
Twist (total washout about 50% chord)	7.97°
Root chord length	8.674 in
Tip chord length	3.288 in
Root chord incidence	2.97°
Leading edge sweep, $\eta = 0.130$ to $\eta = 0.40$, Λ_{LE}	71.0°
Leading edge sweep, $\eta = 0.40$ to $\eta = 1.0$, Λ_{LE}	41.78°
Trailing edge sweep inboard panel, Λ_{TE}	0.0°
Trailing edge sweep panel, Λ_{TE}	33.5°

Vertical Tail V¹

Area, S _v	48.441 in ²
Span, b _v	6.960 in
Mean aerodynamic chord length	6.989 in
Sweep of 35% chord, $\Lambda_{0.35}$	42.5°
Tip chord	6.187 in
Root chord	7.733 in
Aspect ratio	0.991
Taper ratio, λ	0.8

TABLE 1. - MODEL DIMENSIONAL DATA - Concluded.

Horizontal Tail H¹

Area, S _H	45.957 in ²
Span, b _H	13.558 in
Mean aerodynamic chord length	3.597 in
Sweep of 35% chord, Λ _{0.35}	39.04°
Tip chord	1.937 in
Root chord	4.842 in
Aspect ratio	4.0
Taper ratio, λ	0.4
Horizontal tail arm	28.728 in

Nacelle; inboard N¹, outboard N²

Nacelle length	5.47 in
Maximum diameter	1.85 in
Inlet capture area	1.96 in ²
Inboard nacelle centerline location, η = 0.40	B.L. 9.139
Outboard nacelle centerline location, η = 0.70	B.L. 15.993
Nacelle centerline cant, ε	-2.00°
toeout, σ	0.0°
roll, φ	0.0°

Pylon; inboard K¹, outboard K²

Inboard maximum length	9.84 in
Outboard maximum length	8.35 in

TABLE 2. - PRESSURE TUBE LOCATIONS (LEFT WING)

B.L. 4.250 c = 15.031 in				B.L. 7.768 c = 7.466 in				B.L. 11.424 c = 5.981 in				B.L. 18.278 c = 4.366 in			
Upper		Lower		Upper		Lower		Upper		Lower		Upper		Lower	
%c	tube no.	%c	tube no.	%c	tube no.	%c	tube no.	%c	tube no.	%c	tube no.	%c	tube no.	%c	tube no.
0	1	--	--	0	32	--	--	0	63	--	--	--	--	--	--
2	2	2.5	19	2	33	2.5	50	2	64	2.5	80	2	93	5	105
5	3	7.5	20	5	34	7.5	51	5	65	7.5	81	6.5	94	--	--
10	4	12.5	21	10	35	12.5	52	10	66	12.5	82	12.5	95	12.5	106
15	5	--	--	15	36	--	--	15	67	--	--	20	96	20	107
20	6	20	22	20	37	20	53	20	68	20	83	30	97	30	108
25	7	--	--	25	38	--	--	30	69	30	84	40	98	40	109
30	8	30	23	30	39	30	54	40	70	40	85	50	99	50	110
40	9	40	24	40	40	40	55	50	71	50	86	60	100	60	111
50	10	50	25	50	41	50	56	56	72	60	87	68	101	70	112
56	11	60	26	56	42	60	57	62	73	67.5	88	76	102	80	113
62	12	67.5	27	62	43	67.5	58	68	74	75	89	84	103	90	114

TABLE 2. - PRESSURE TUBE LOCATIONS (LEFT WING) - Concluded.

B.L. 4.250 c = 15.031 in		B.L. 7.768 c = 7.466 in		B.L. 11.424 c = 5.981 in		B.L. 18.278 c = 4.366 in									
Upper		Lower		Upper		Lower		Upper		Lower					
%c	tube no.	%c	tube no.	%c	tube no.	%c	tube no.	%c	tube no.	%c	tube no.				
68	13	75	28	68	44	75	59	74	75	82.5	90	92	104	--	--
74	14	82.5	29	74	45	82.5	60	80	76	90	91	--	---	--	--
80	15	90	30	80	46	90	61	86	77	95	92	--	--	--	--
86	16	95	31	86	47	95	62	92	78	--	--	---	--	--	--
92	17	--	---	92	48	--	--	98	79	--	--	--	--	--	--
98	18	--	---	98	49	--	--	--	--	--	--	--	--	--	--

[REDACTED]

TABLE 3. - INDEX OF DATA FIGURES

Figure	Title	Page
4	Effect of addition of major components on longitudinal aerodynamics, grit type 1.	1
5	Effect of addition of major components on longitudinal aerodynamics, grit type 2.	17
6	Effect of addition of major components on lateral-directional aerodynamics in sideslip.	27
7	Effect of addition of major components on lateral-directional aerodynamics in pitch.	29
8	Effect of horizontal tail deflection on longitudinal aerodynamic characteristics of full configuration.	33
9	Effect of horizontal tail deflection on longitudinal aerodynamic characteristics of wing-body-tail.	39
10	Effect of spoilers on longitudinal aerodynamics.	45
11	Effect of spoilers on lateral-directional aerodynamics at beta equal to zero.	51
12	Effect of model components on longitudinal aerodynamics.	54
13	Effect of body area rule on longitudinal aerodynamics.	70
14	Effect of Mach number on longitudinal aerodynamics.	76
15	Contribution of model components to longitudinal aerodynamics as a function of Mach.	80
16	Effect of Mach number on longitudinal control.	84
17	Effect of Mach number on lateral-directional stability.	86
18	Effect of Mach number on lateral-directional control.	87
19	Wing pressure distributions for basic wing-body.	92

TABLE 3. - INDEX OF DATA FIGURES - Concluded.

Figure	Title	Page
20	Wing pressure distributions for full model configuration.	136
21	Effect of spoilers on wing pressure distributions, wing upper surface.	172
22	Effect of spoilers on wing pressure distributions, wing lower surface.	192
23	Effect of transition strip location on wing pressure distributions, wing upper surface.	212
24	Effect of transition strip location on wing pressure distributions, wing lower surface.	220
25	Effect of body area rule on wing pressure distributions, wing upper surface.	228
26	Effect of body area rule on wing pressure distributions, wing lower surface.	236

Notes:

1. Positive directions of force coefficients, moment coefficients, and angles are indicated by arrow
2. For clarity, origins of wind and stability axes have been displaced from the center of gravity

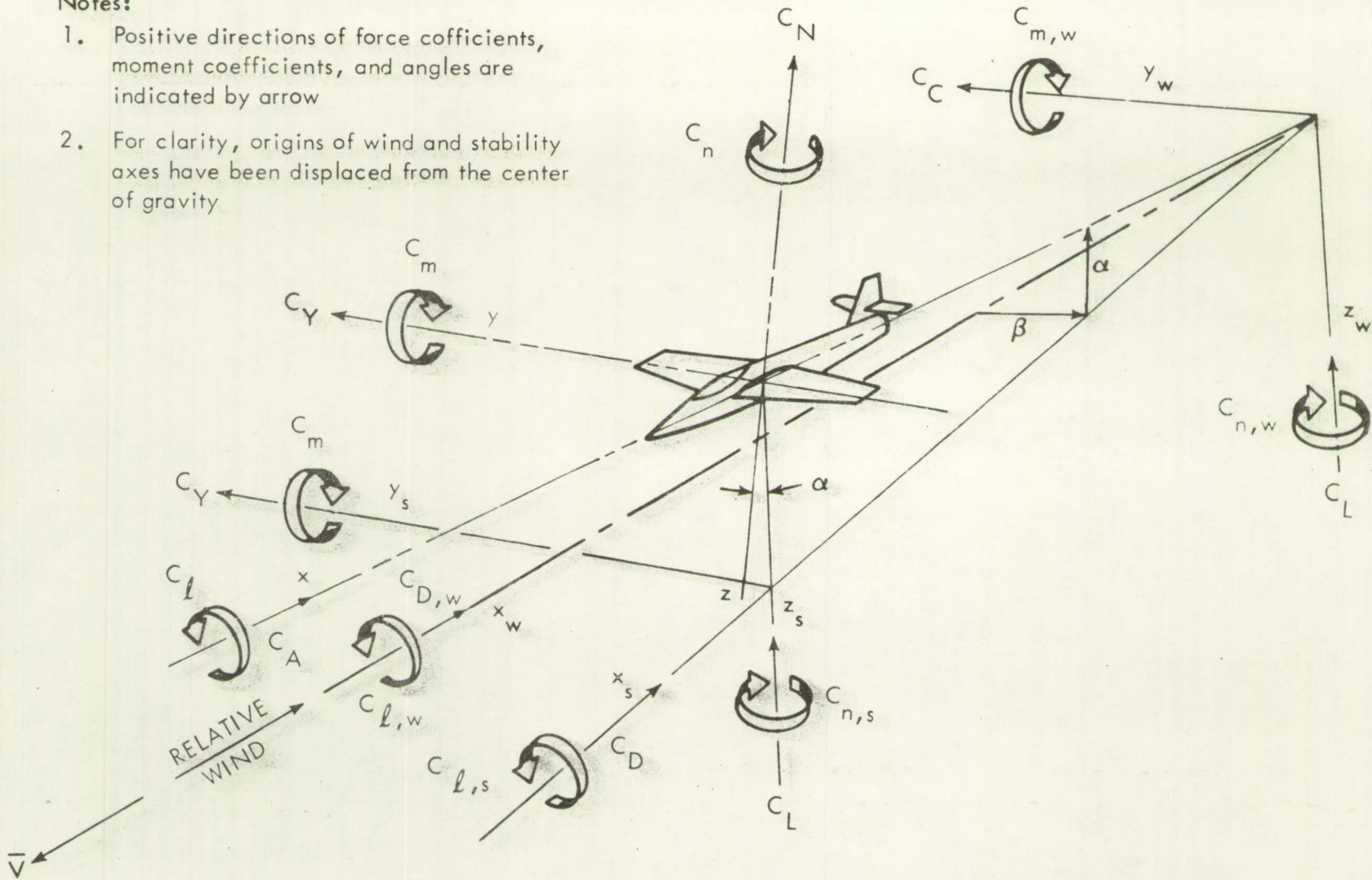
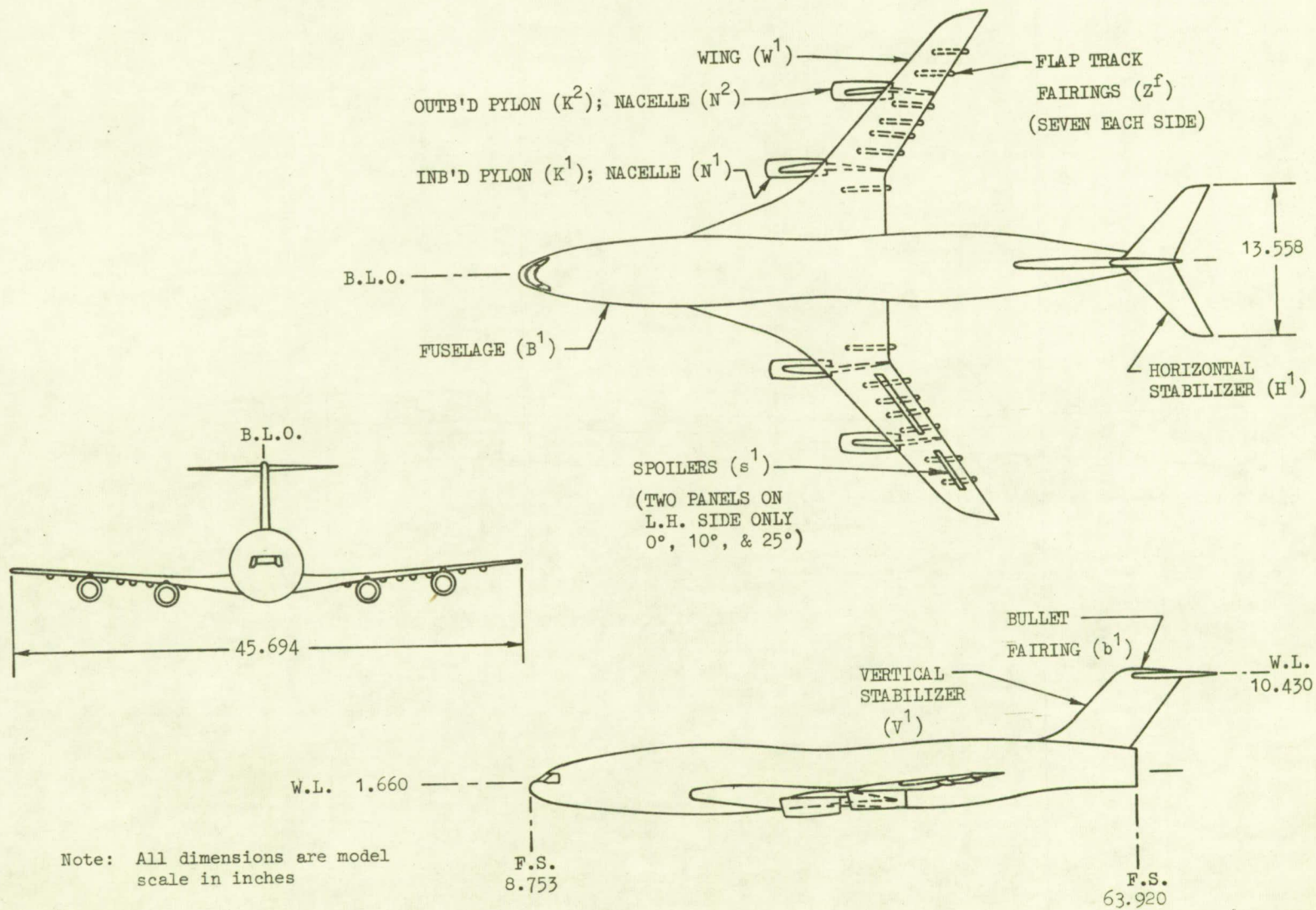
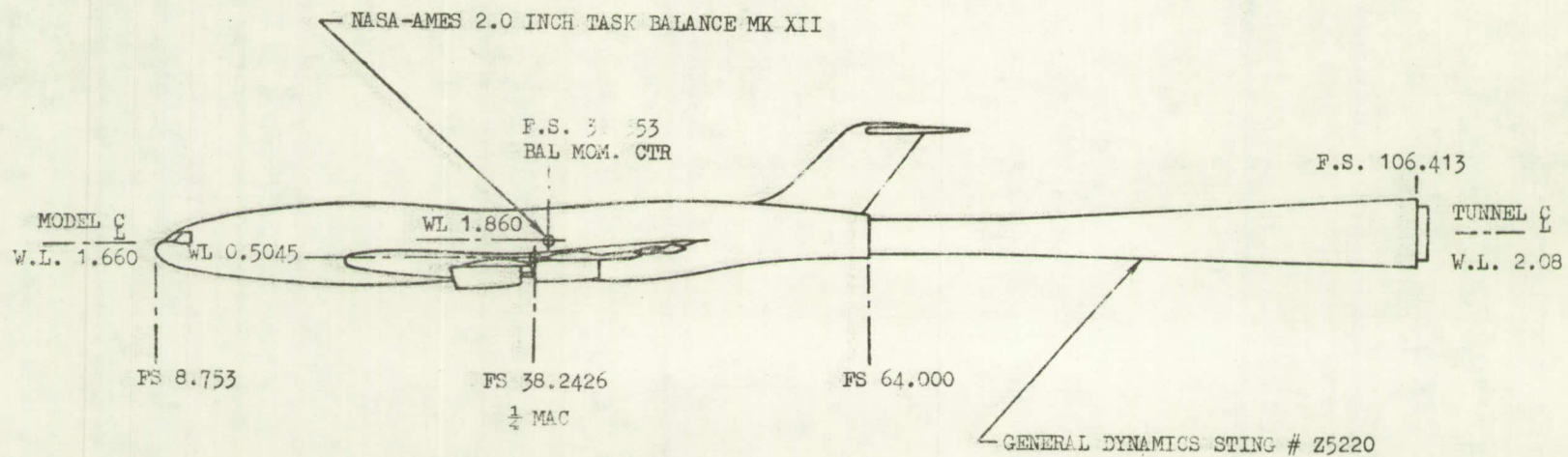

Figure 1. - Axis systems.



(a) Three-view drawing

Figure 2. - Model details.



(b) Sting support
Figure 2. - Continued.

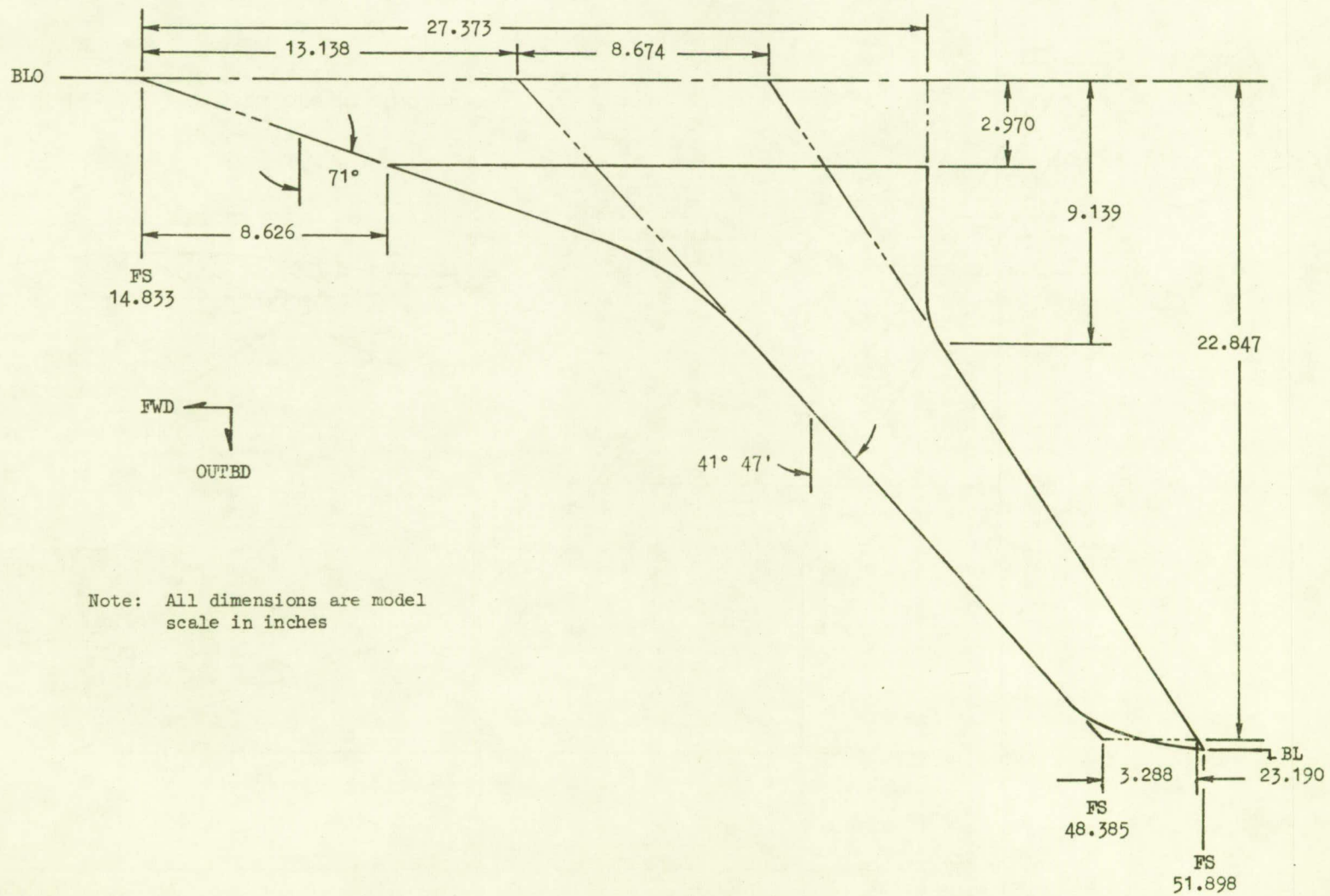

Note: All dimensions are model scale in inches

(c) Wing planform
Figure 2. - Continued.

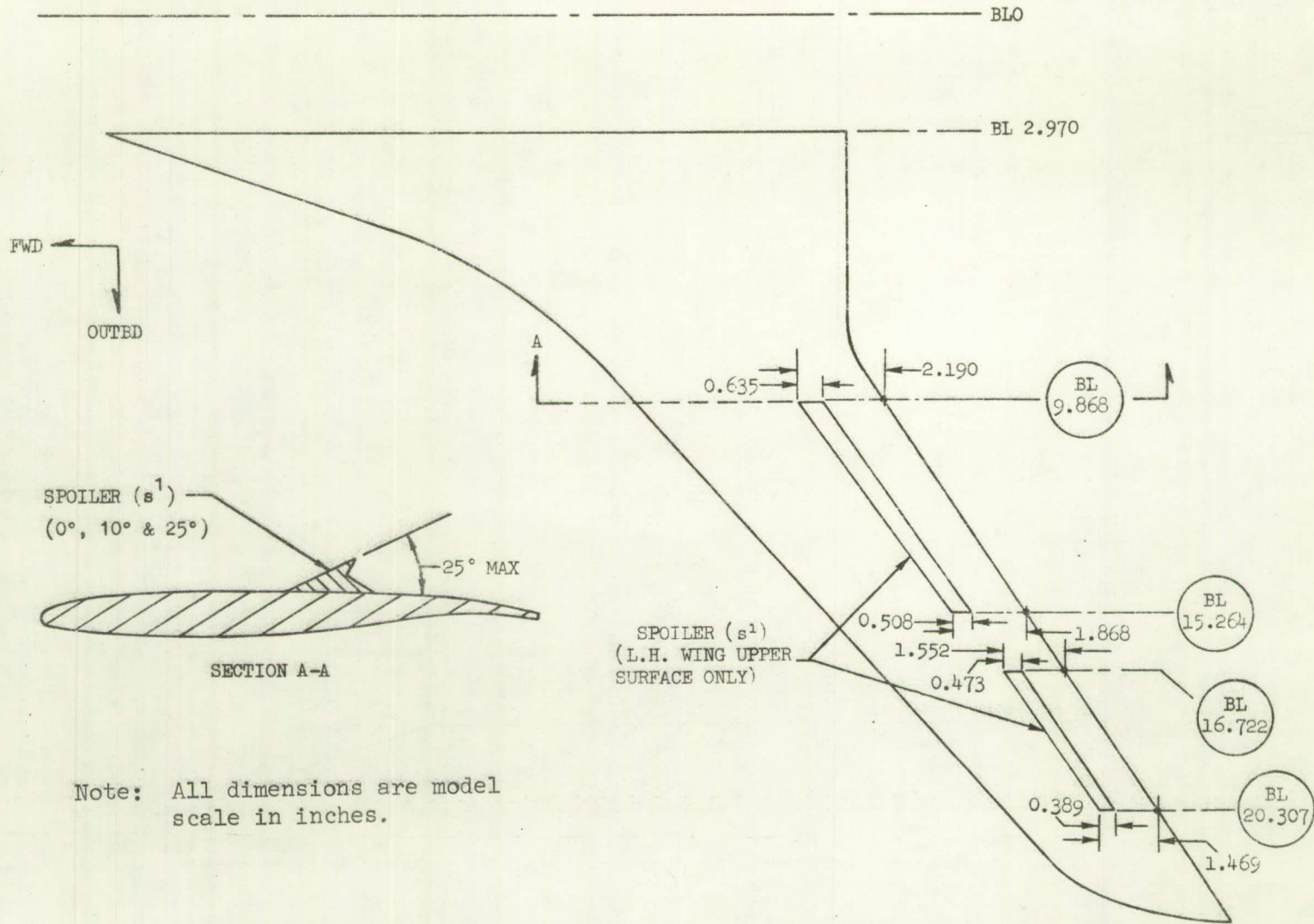

(d) Spoilers

Figure 2. - Continued.

CONFIDENTIAL
21

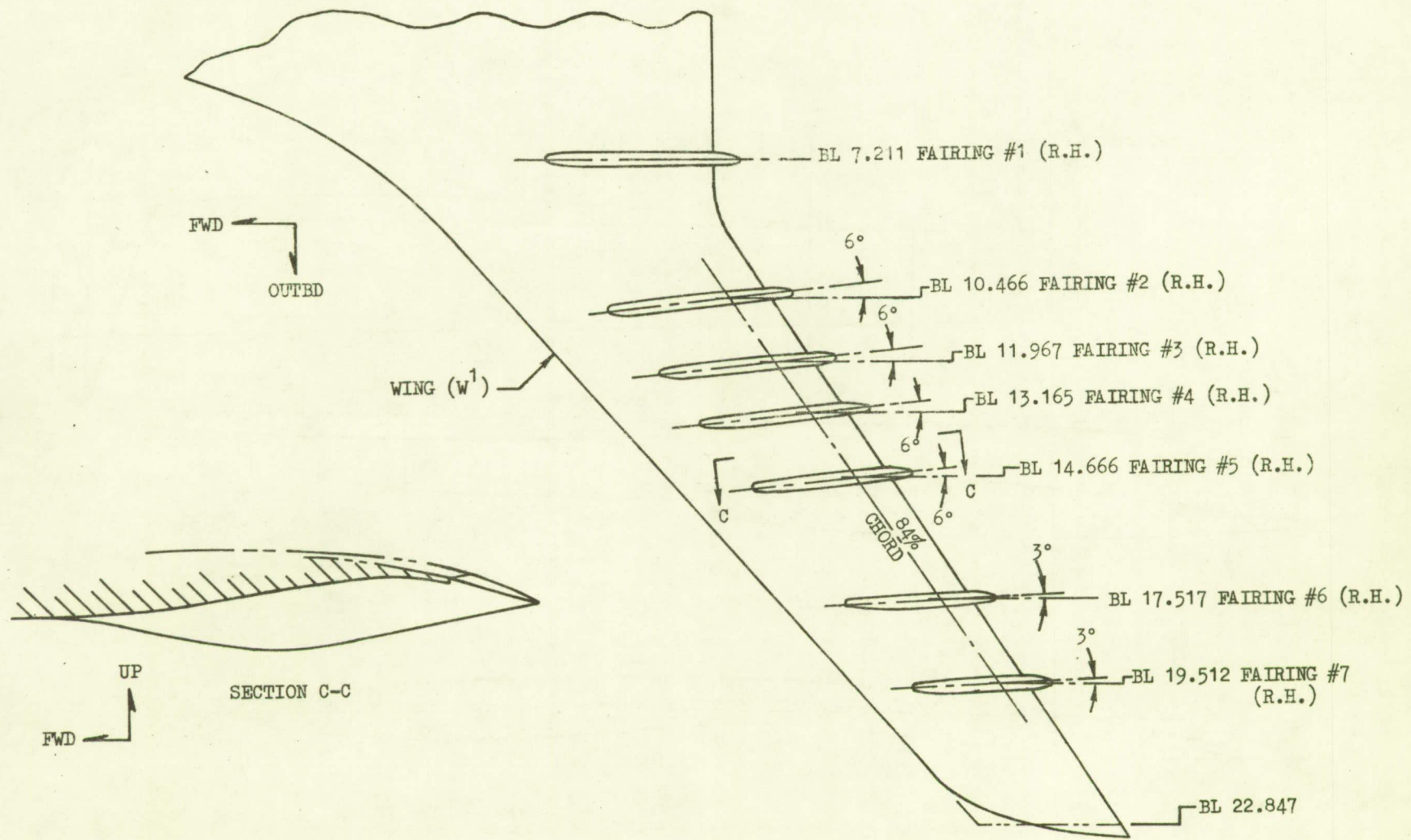

(e) Flap track fairings
Figure 2. - Continued.

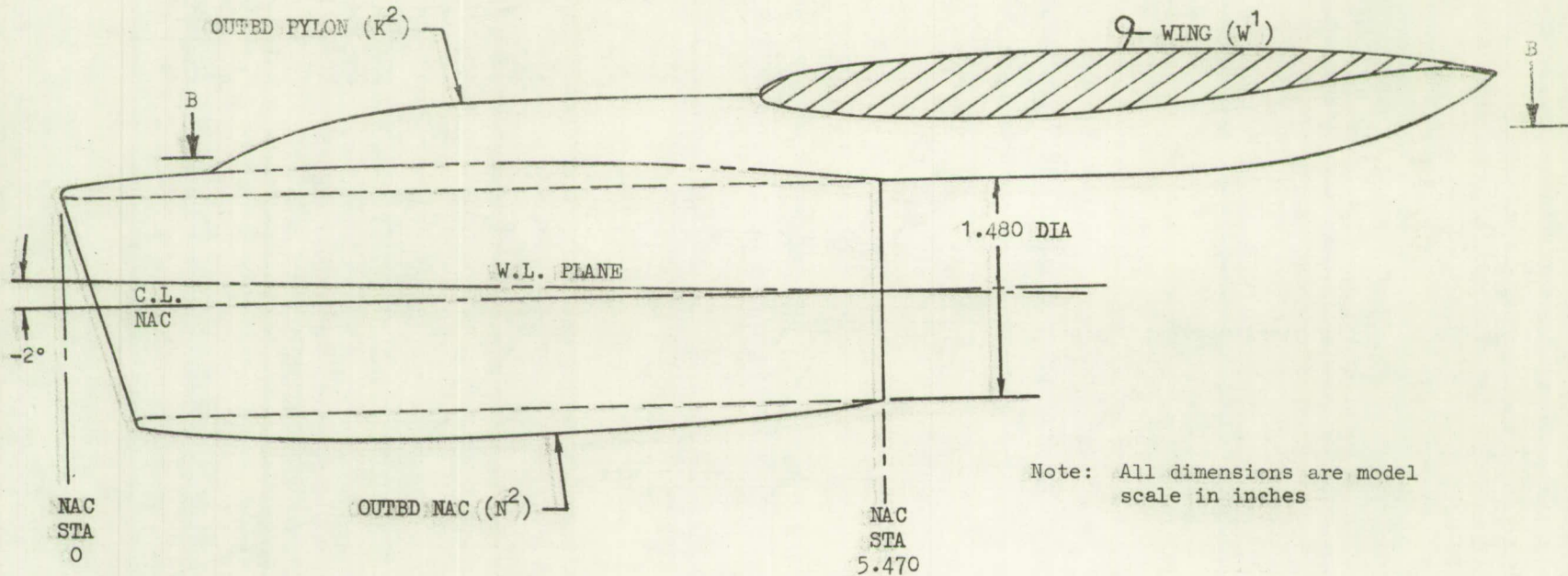
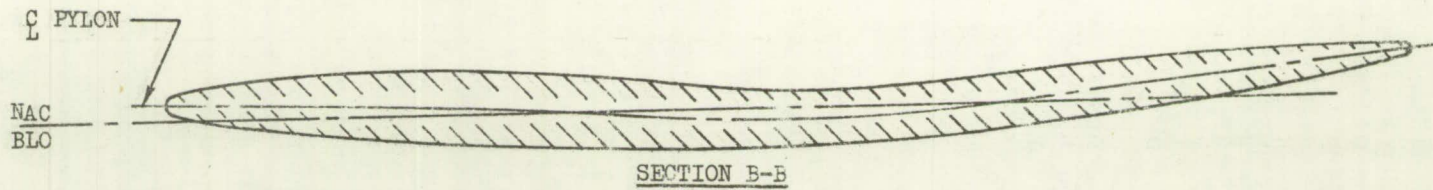

22

(f) Typical pylon/nacelle assembly

Figure 2. - Continued.

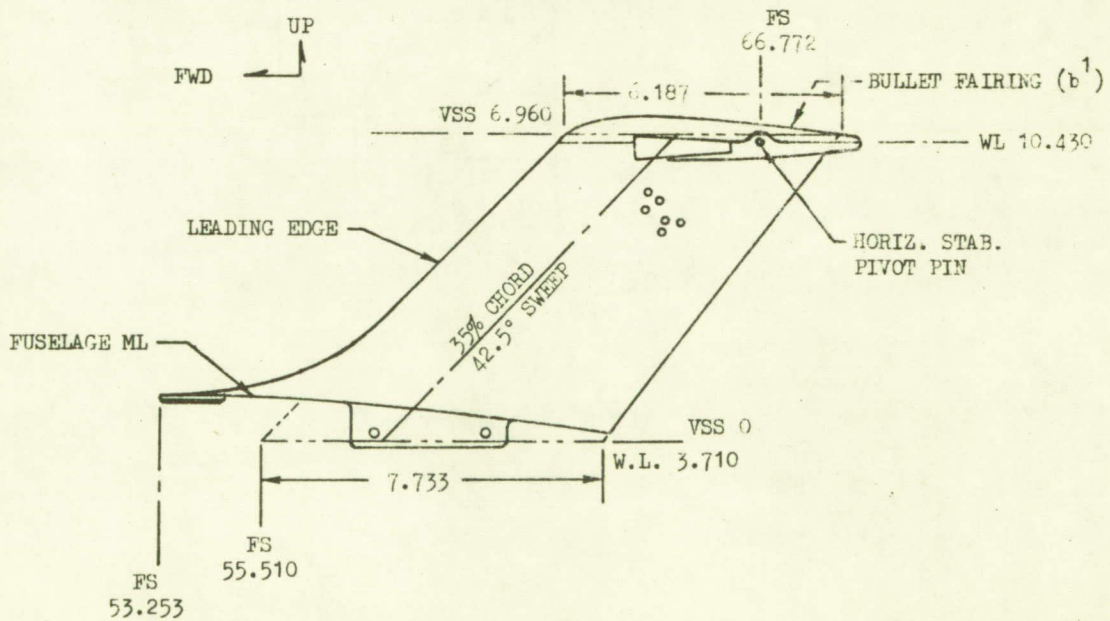
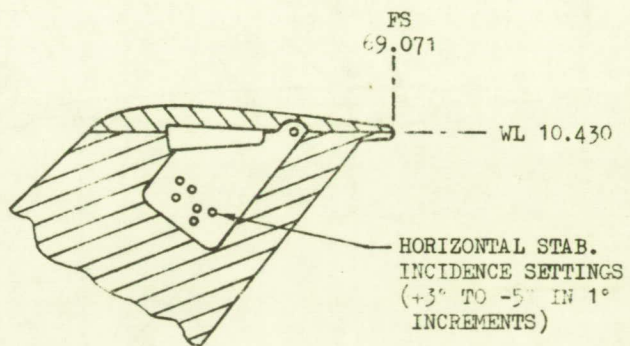
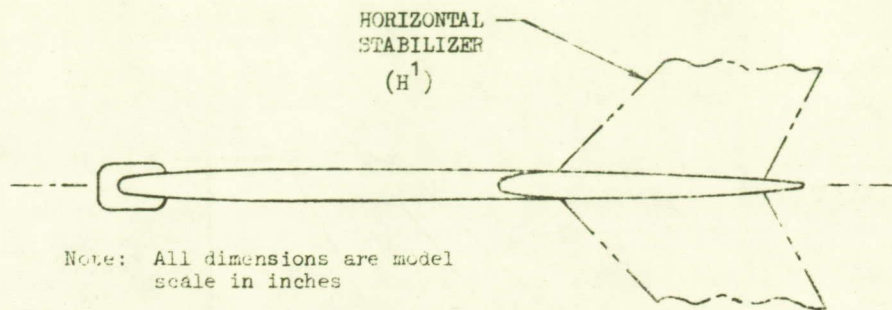

(g) Vertical tail

Figure 2. - Continued.

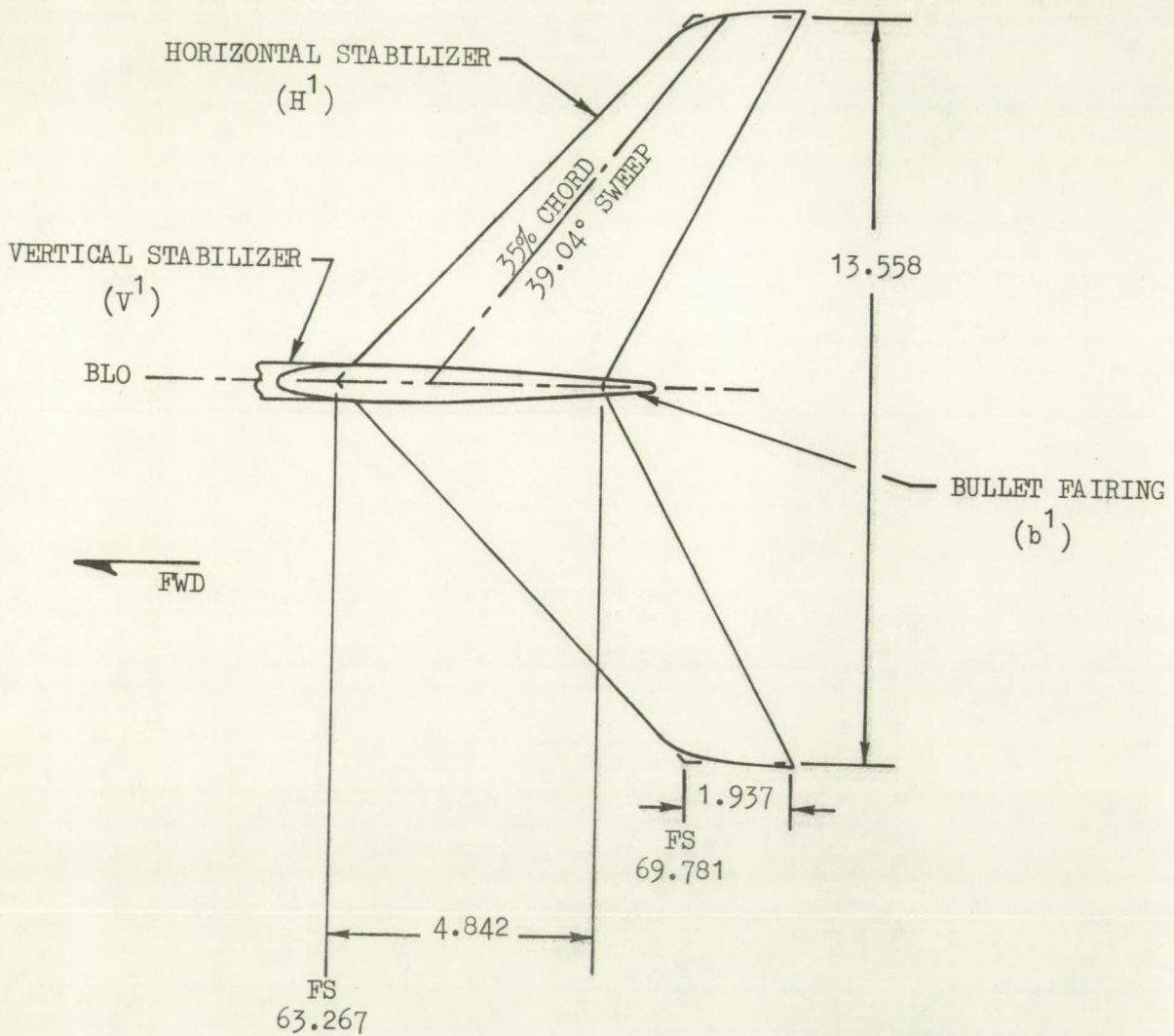

Note: All dimensions are model scale in inches

(h) Horizontal tail

Figure 2. - Continued.

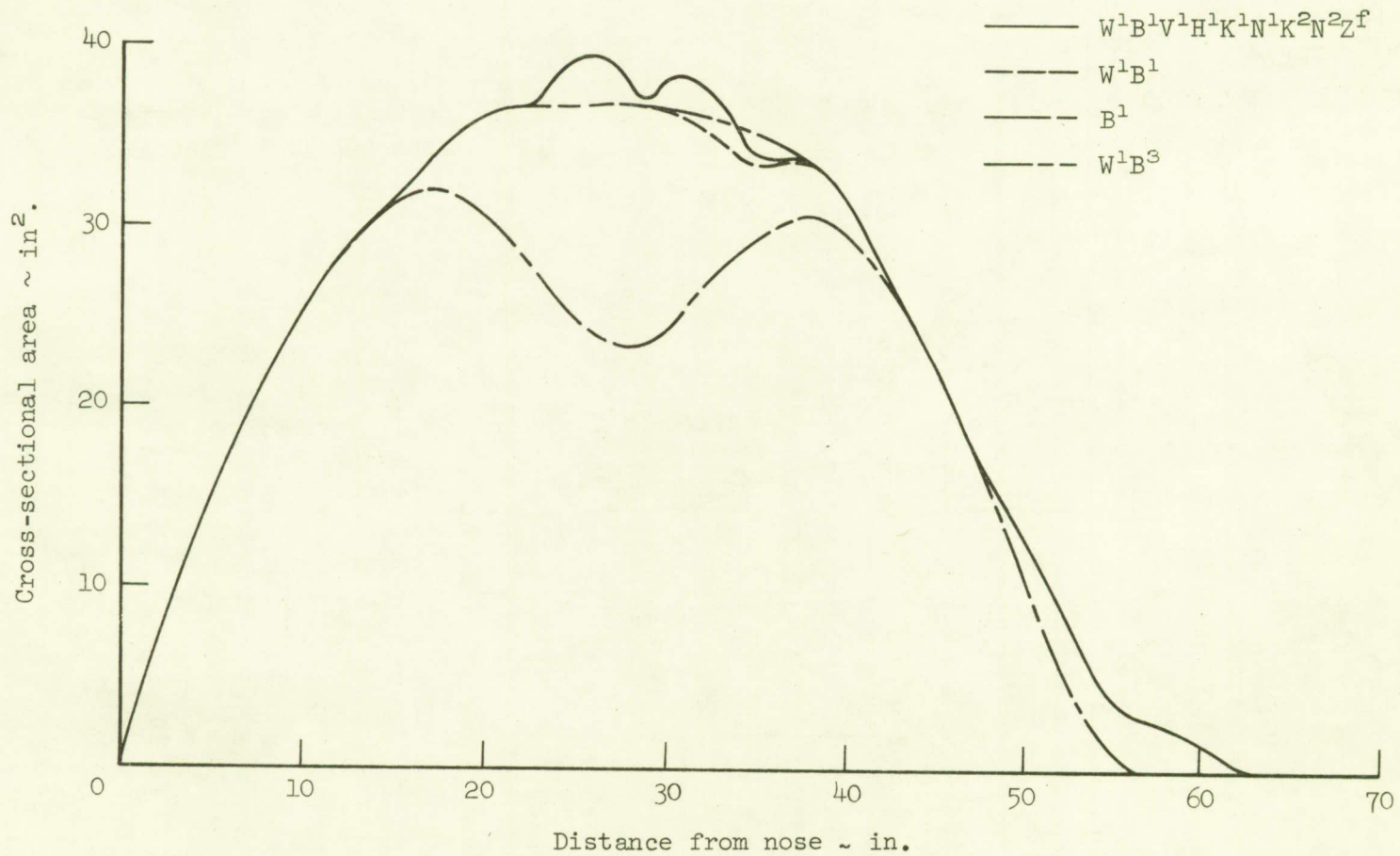

(i) Model cross-sectional area distributions

Figure 2. - Continued.

WING, SUPERCRITICAL (TRANS = 2)
 UPPER - 0.0076 GRIT, 0.05 IN. WIDE
 LOWER - SAME AS SUBCRITICAL

WING, SUBCRITICAL (TRANS = 1)
 UPPER - 0.0038 GRIT, 0.05 IN. WIDE
 LOWER - 0.0054 GRIT, 0.05 IN. WIDE

NACELLE

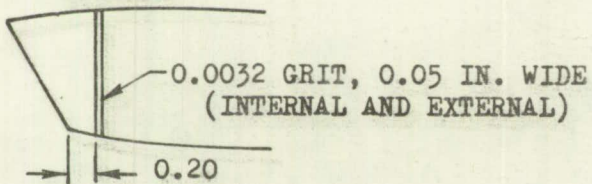

Note: All dimensions are model scale in inches.

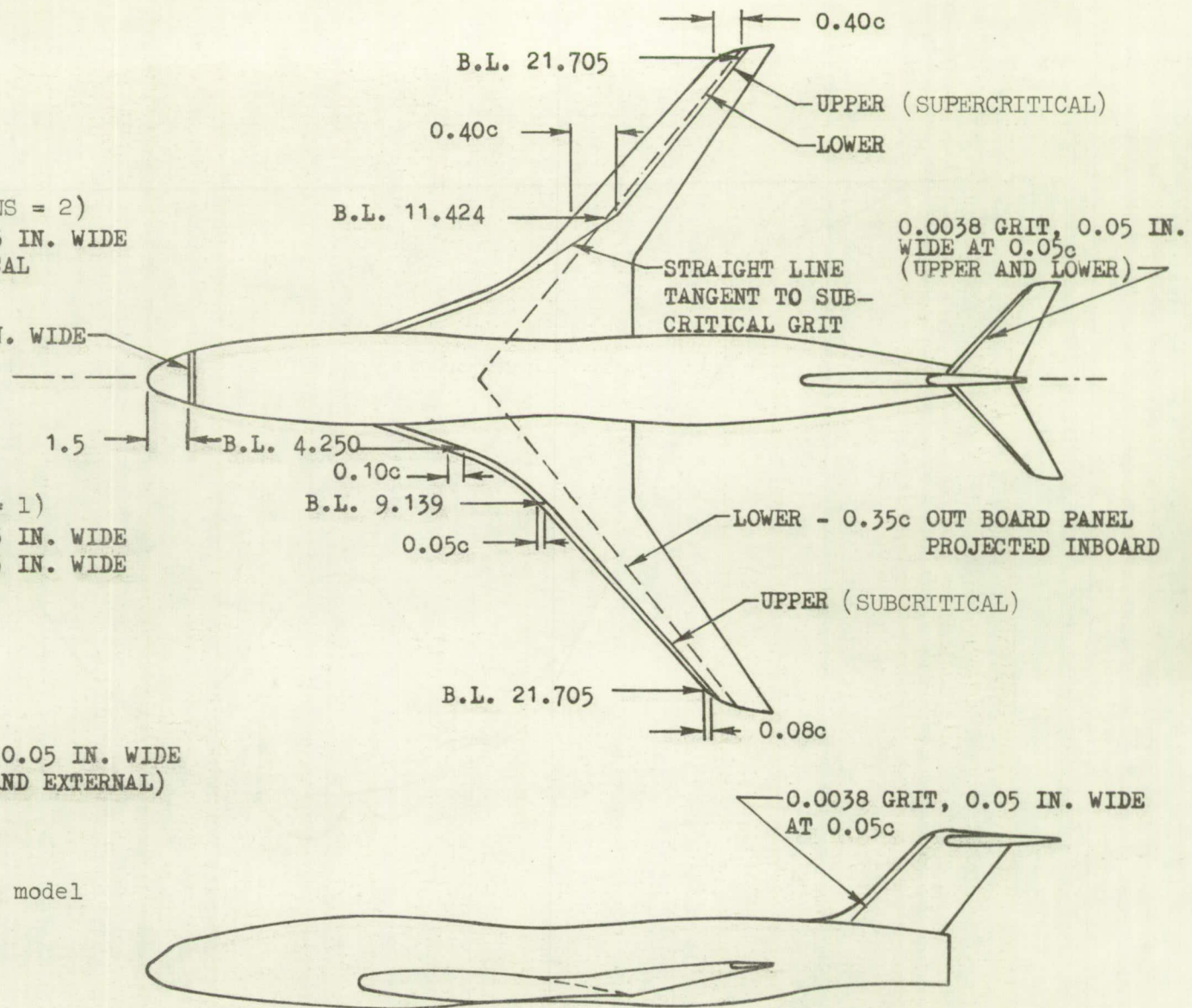

(j) Transition strip detail

Figure 2. - Concluded.

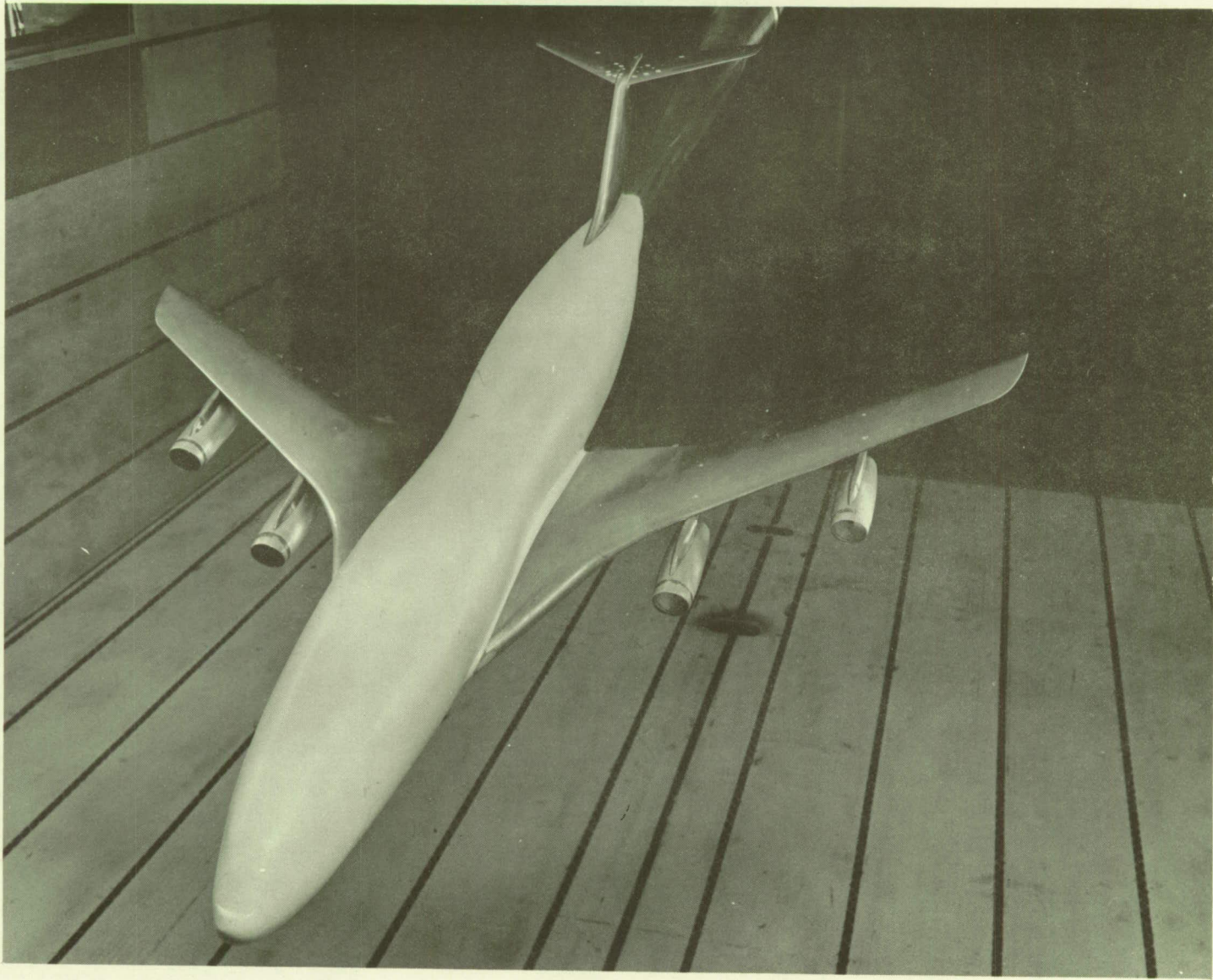

(a) Front view

Figure 3. - Model installed in Ames 11- by 11-Foot Transonic Wind Tunnel.

~~CONFIDENTIAL~~

28

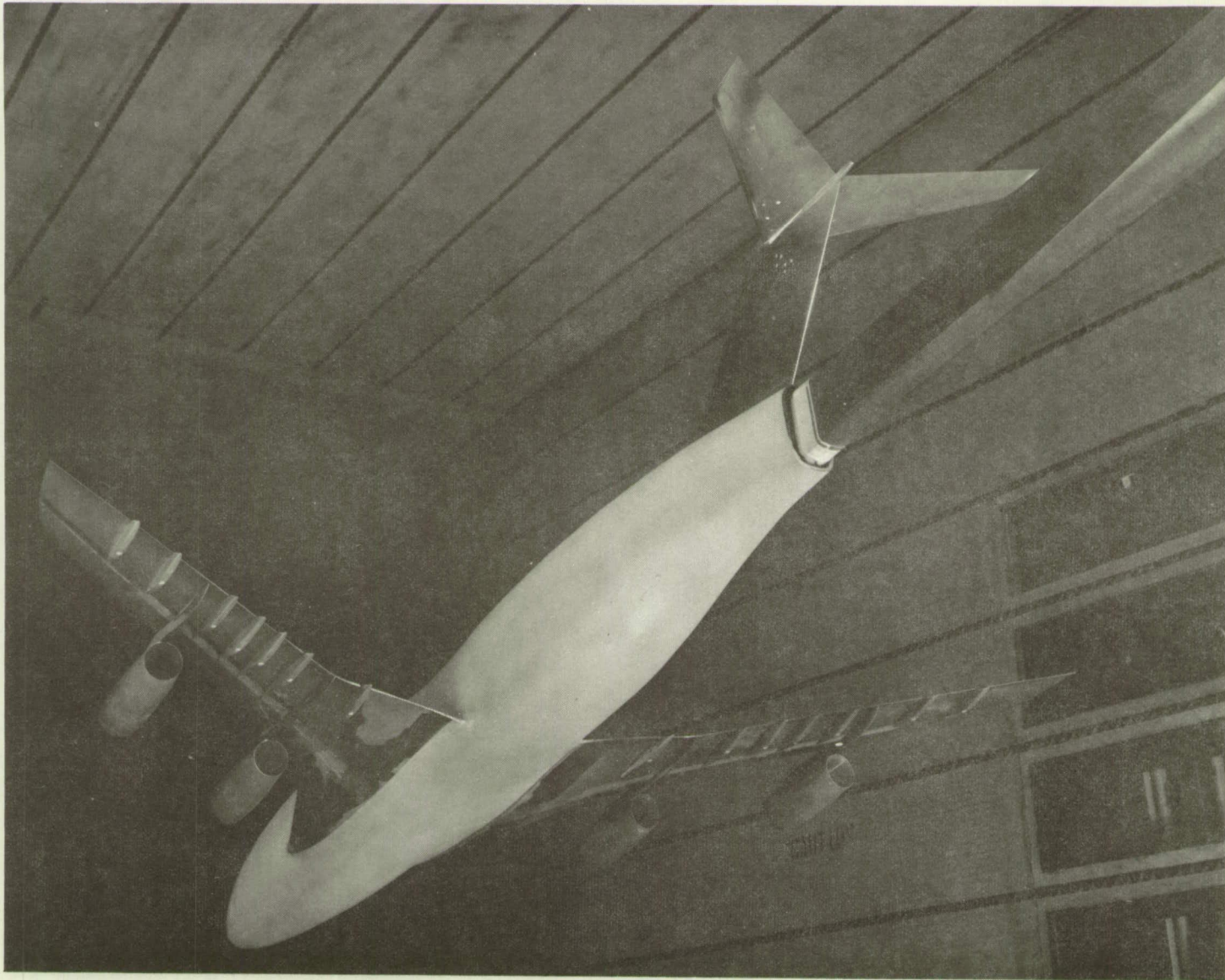

~~CONFIDENTIAL~~

(b) Rear view
Figure 3. - Concluded.

~~CONFIDENTIAL~~

DATA

29
~~CONFIDENTIAL~~

DATA SET SYMBOL	CONFIGURATION DESCRIPTION
(HAF024) ○	W1 B1
(RAFD07) △	DATA NOT AVAILABLE
(RAFD13) ◇	W1 B1 V1 H1 K1 N1 K2 N2 ZF1

BETA	HORIZT	SPLR-L	TRANS
0.000		0.000	1.000
0.000	-1.000	0.000	1.000
0.000	-1.000	0.000	1.000

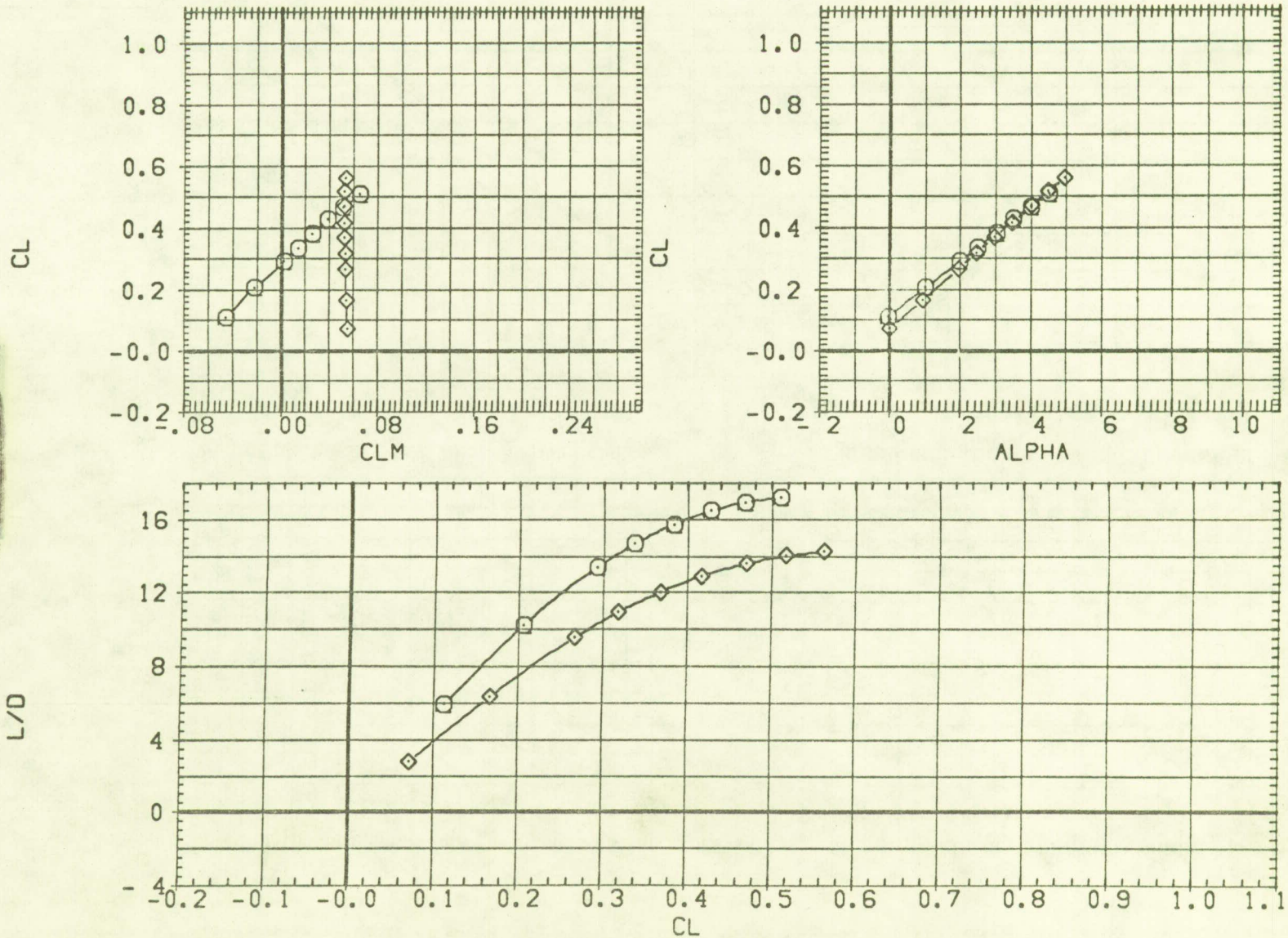

FIG 4 EFFECT OF ADDITION OF MAJOR COMPONENTS ON LONG. AERODYNAMICS. GRIT TYPE 1

(A)MACH = 0.50

DATA SET SYMBOL	CONFIGURATION DESCRIPTION
(HAF024)	W1 B1
(RAFO07)	W1 B1 V1 H1
(RAFD13)	W1 B1 V1 H1 K1 N1 K2 N2 ZF1

BETA	HORIZT	SPLR-L	TRANS
0.000	0.000	0.000	1.000
0.000	-1.000	0.000	1.000
0.000	-1.000	0.000	1.000

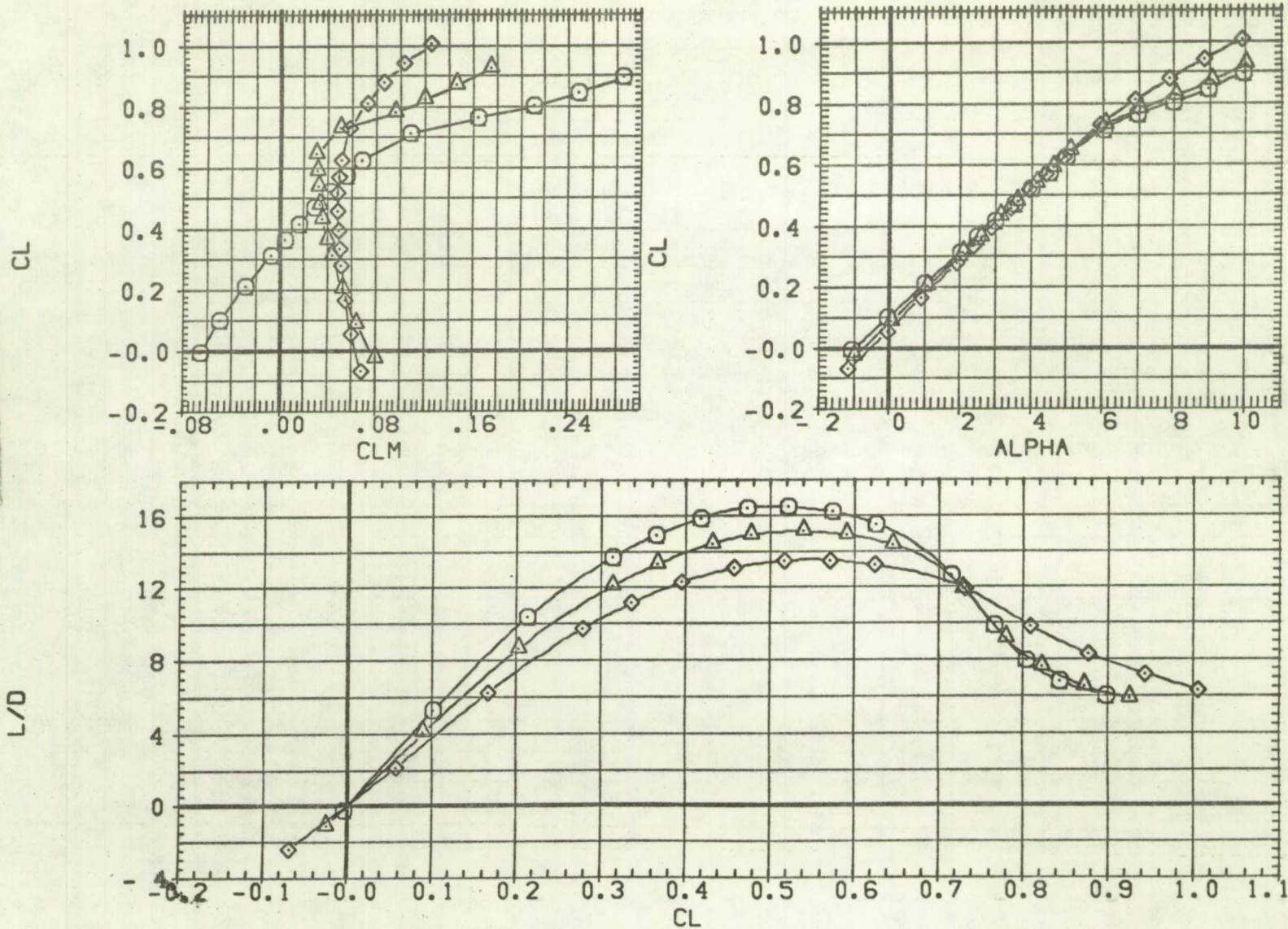

FIG 4 EFFECT OF ADDITION OF MAJOR COMPONENTS ON LONG. AERODYNAMICS. GRIT TYPE 1
 (B)MACH = 0.80

DATA SET SYMBOL	CONFIGURATION DESCRIPTION
(HAF024)	W1 B1
(RAF007)	W1 B1 V1 H1
(RAF013)	W1 B1 V1 H1 K1 N1 K2 N2 ZF1

BETA	HORIZT	SPLR-L	TRANS
0.000		0.000	1.000
0.000	-1.000	0.000	1.000
0.000	-1.000	0.000	1.000

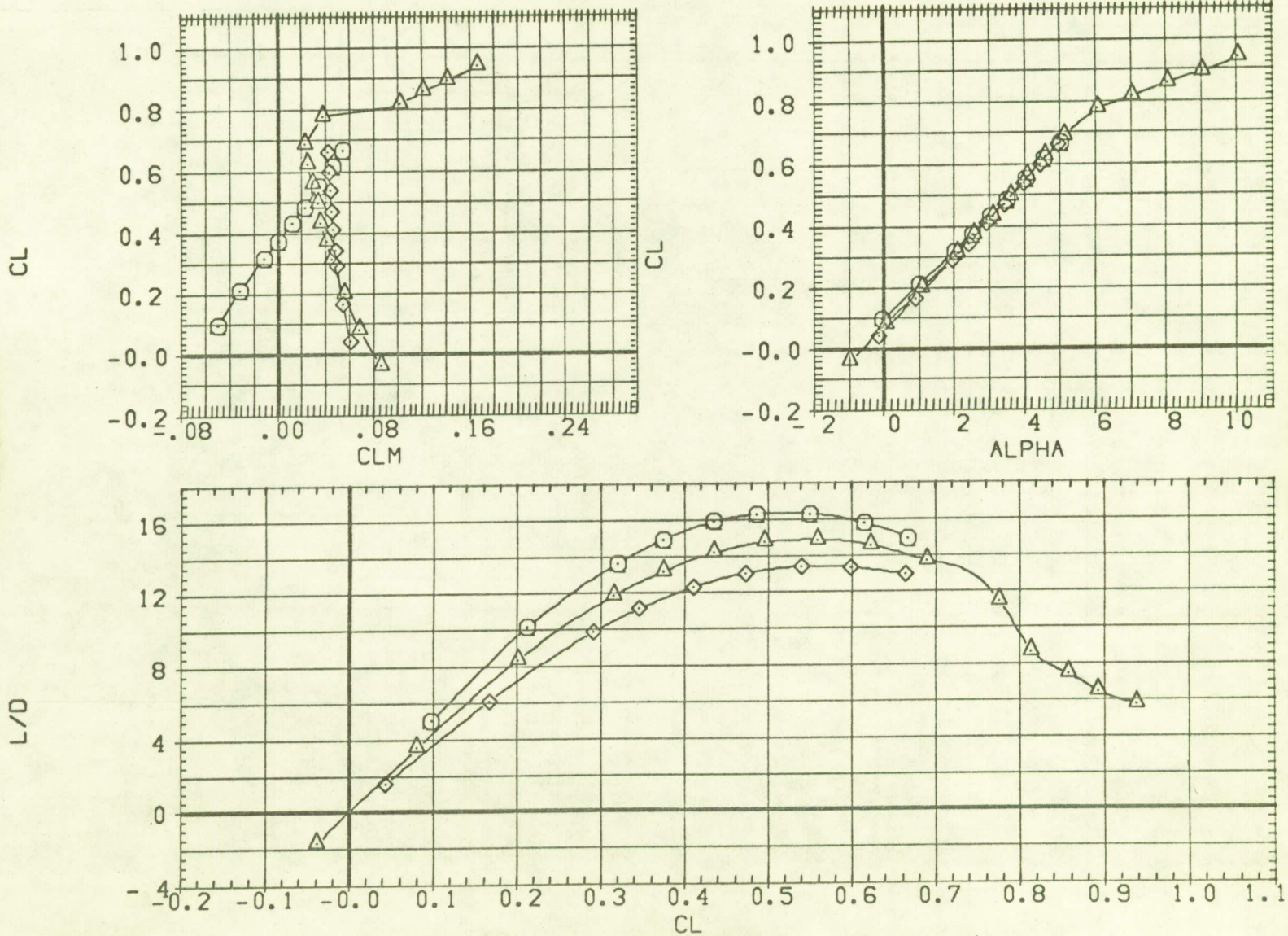

FIG 4 EFFECT OF ADDITION OF MAJOR COMPONENTS ON LONG. AERODYNAMICS. GRIT TYPE 1
 (C)MACH = 0.85

DATA SET SYMBOL CONFIGURATION DESCRIPTION

(HAF024)	○	W1 B1
(RAF007)	△	W1 B1 V1 H1
(RAF013)	◇	W1 B1 V1 H1 K1 N1 K2 N2 ZF1

BETA	HORIZT	SPLR-L	TRANS
0.000		0.000	1.000
0.000	-1.000	0.000	1.000
0.000	-1.000	0.000	1.000

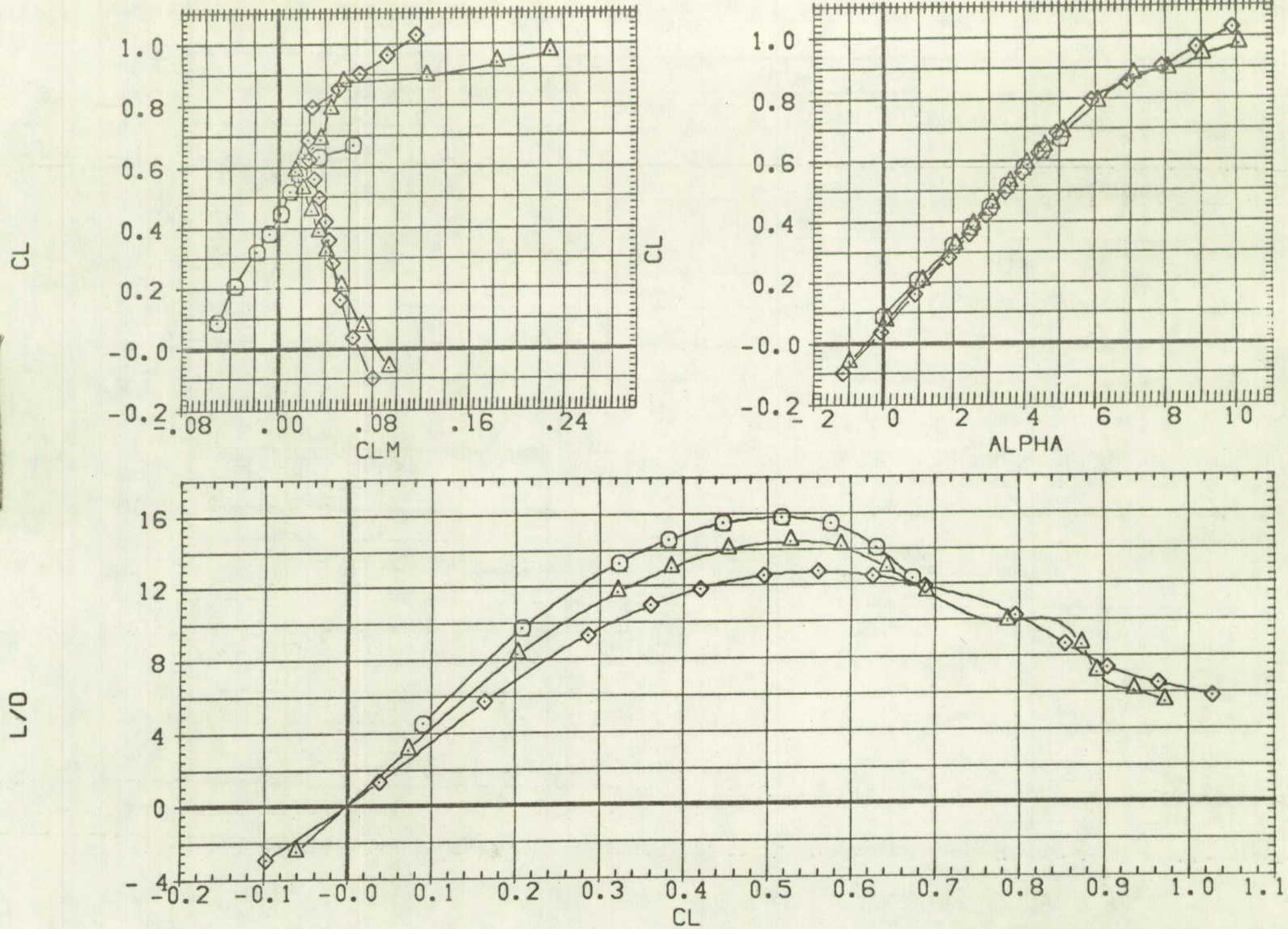

FIG 4 EFFECT OF ADDITION OF MAJOR COMPONENTS ON LONG. AERODYNAMICS. GRIT TYPE 1
 (D)MACH = 0.90

DATA SET SYMBOL CONFIGURATION DESCRIPTION
 (HAF024) ○ W1 B1
 (RAF007) △ W1 B1 V1 H1
 (RAF013) ◇ W1 B1 V1 H1 K1 N1 K2 N2 ZF1

BETA	HORIZT	SPLR-L	TRANS
0.000		0.000	1.000
0.000	-1.000	0.000	1.000
0.000	-1.000	0.000	1.000

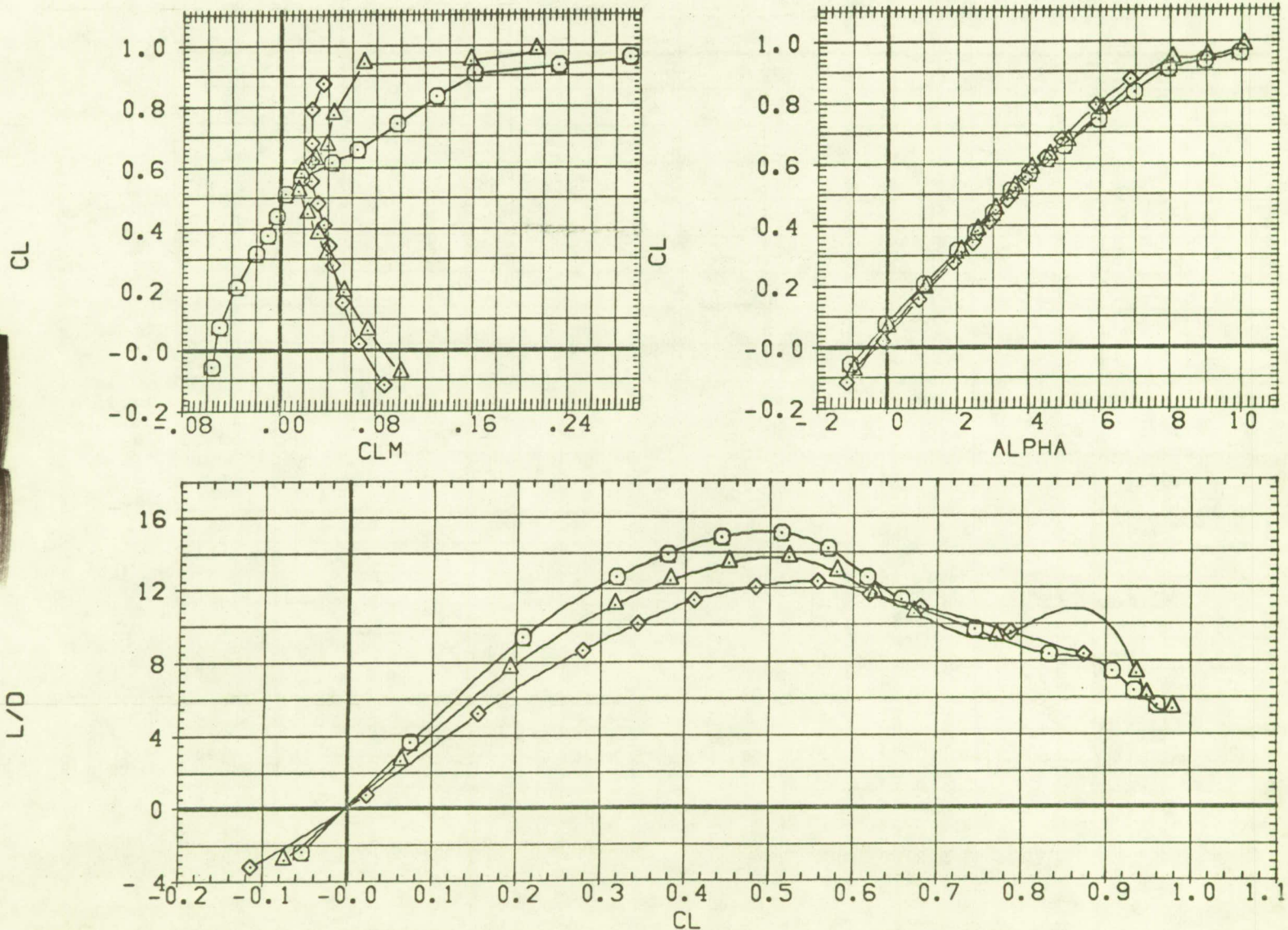

FIG 4 EFFECT OF ADDITION OF MAJOR COMPONENTS ON LONG. AERODYNAMICS. GRIT TYPE 1
 (E)MACH = 0.92

DATA SET SYMBOL CONFIGURATION DESCRIPTION

(HAF024) ○ W1 B1

(RAF007) △ W1 B1 V1 H1

(RAF013) ◇ W1 B1 V1 H1 K1 N1 K2 N2 ZF1

BETA	HORIZT	SPLR-L	TRANS
0.000		0.000	1.000
0.000	-1.000	0.000	1.000
0.000	-1.000	0.000	1.000

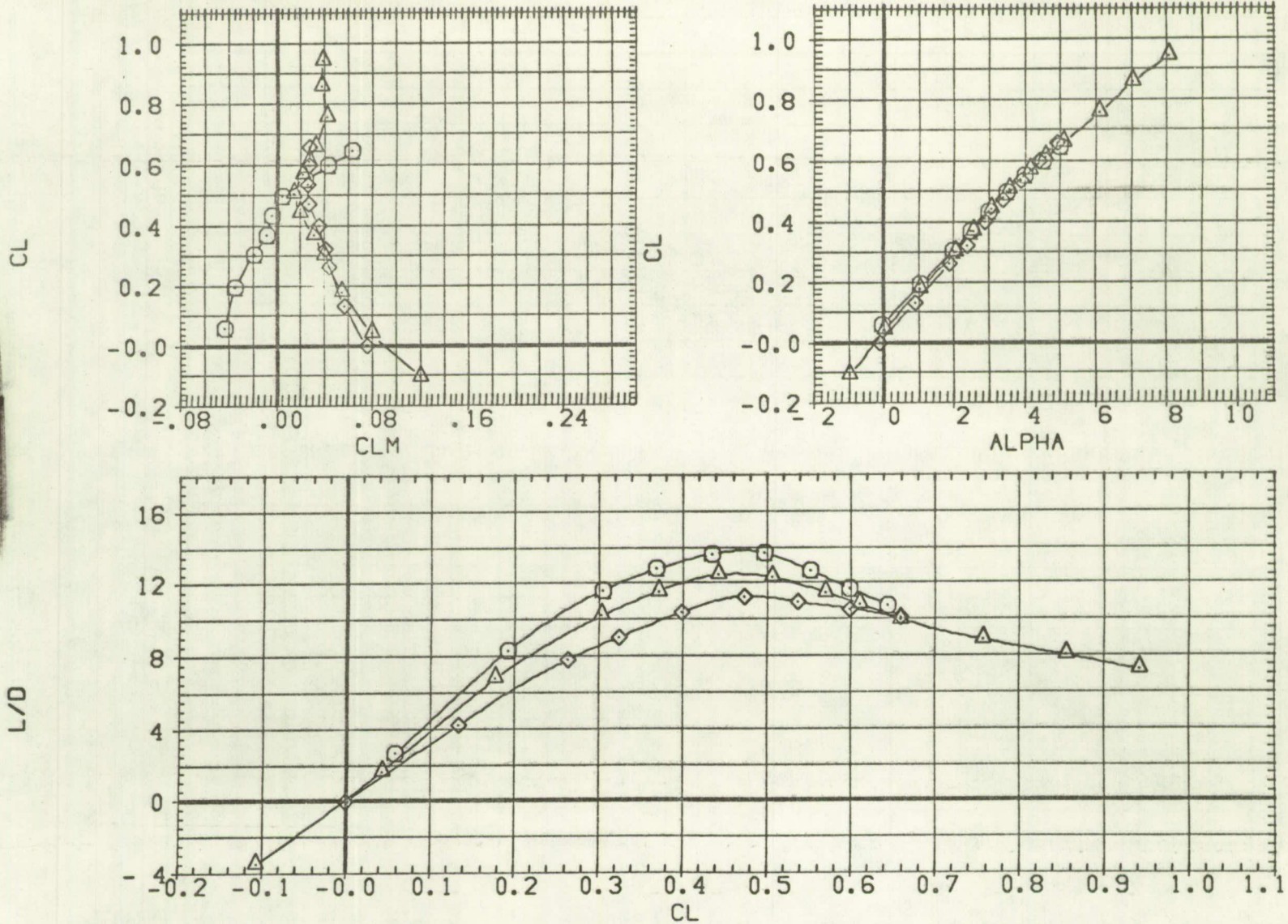

FIG 4 EFFECT OF ADDITION OF MAJOR COMPONENTS ON LONG. AERODYNAMICS. GRIT TYPE 1
 (F)MACH = 0.94

DATA SET SYMBOL	CONFIGURATION DESCRIPTION
(HAF024)	W1 B1
(RAFD07)	W1 B1 V1 H1
(RAFD13)	W1 B1 V1 H1 K1 N1 K2 N2 ZF1

BETA	HORIZT	SPLR-L	TRANS
0.000		0.000	1.000
0.000	-1.000	0.000	1.000
0.000	-1.000	0.000	1.000

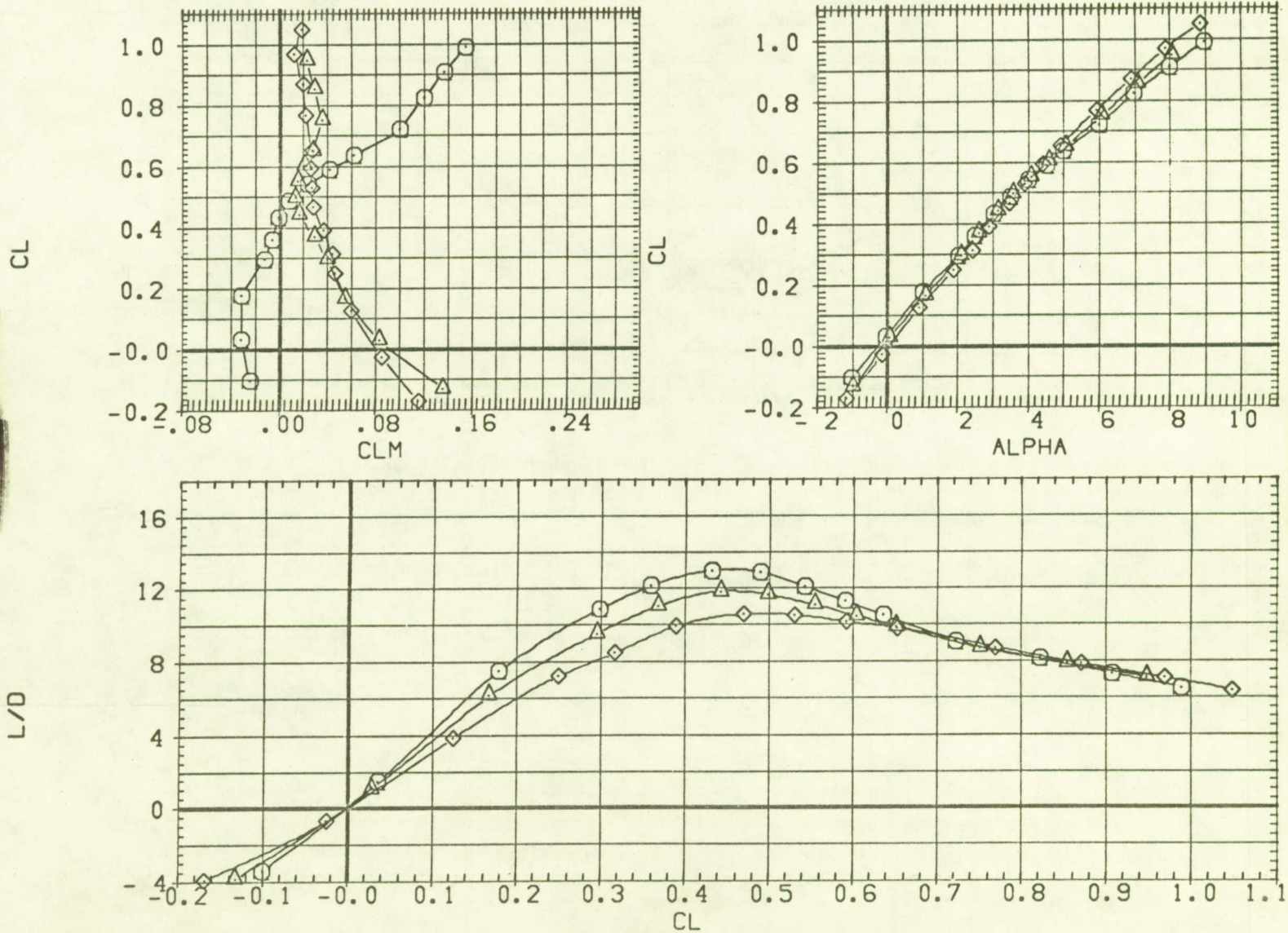

FIG 4 EFFECT OF ADDITION OF MAJOR COMPONENTS ON LONG. AERODYNAMICS. GRIT TYPE 1

DATA SET SYMBOL CONFIGURATION DESCRIPTION

(HAFD24) ○ W1 B1
 (RAFD07) △ W1 B1 V1 H1
 (RAFD13) ◇ DATA NOT AVAILABLE

BETA	HORIZT	SPLR-L	TRANS
0.000		0.000	1.000
0.000	-1.000	0.000	1.000
0.000	-1.000	0.000	1.000

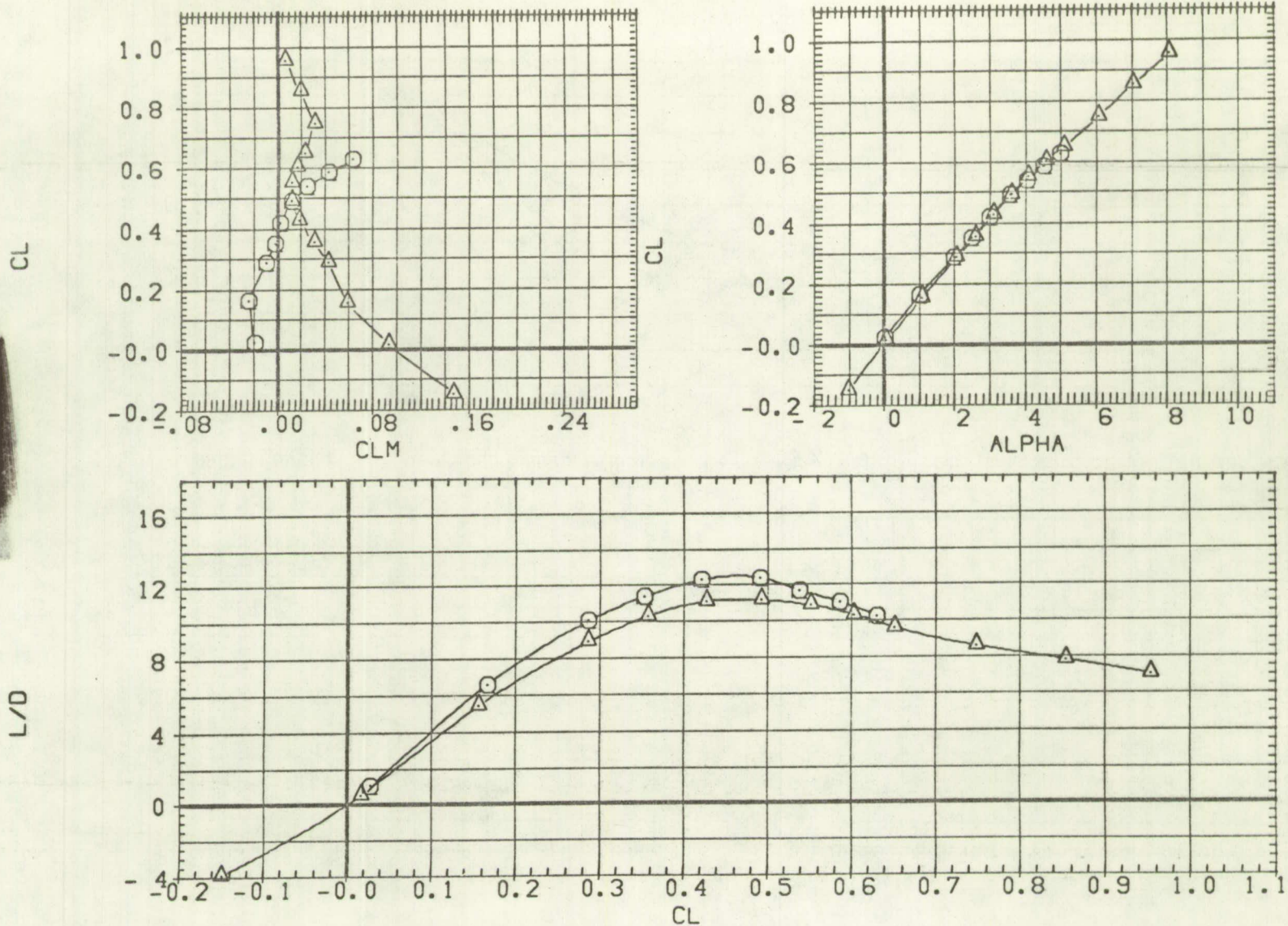

FIG 4 EFFECT OF ADDITION OF MAJOR COMPONENTS ON LONG. AERODYNAMICS. GRIT TYPE 1
 (H)MACH = 0.96

DATA SET SYMBOL	CONFIGURATION DESCRIPTION
(HAF024)	○ W1 B1
(RAFD07)	△ DATA NOT AVAILABLE
(RAFD13)	◇ W1 B1 V1 H1 K1 N1 K2 N2 ZF1

BETA	HORIZT	SPLR-L	TRANS
0.000		0.000	1.000
0.000	-1.000	0.000	1.000
0.000	-1.000	0.000	1.000

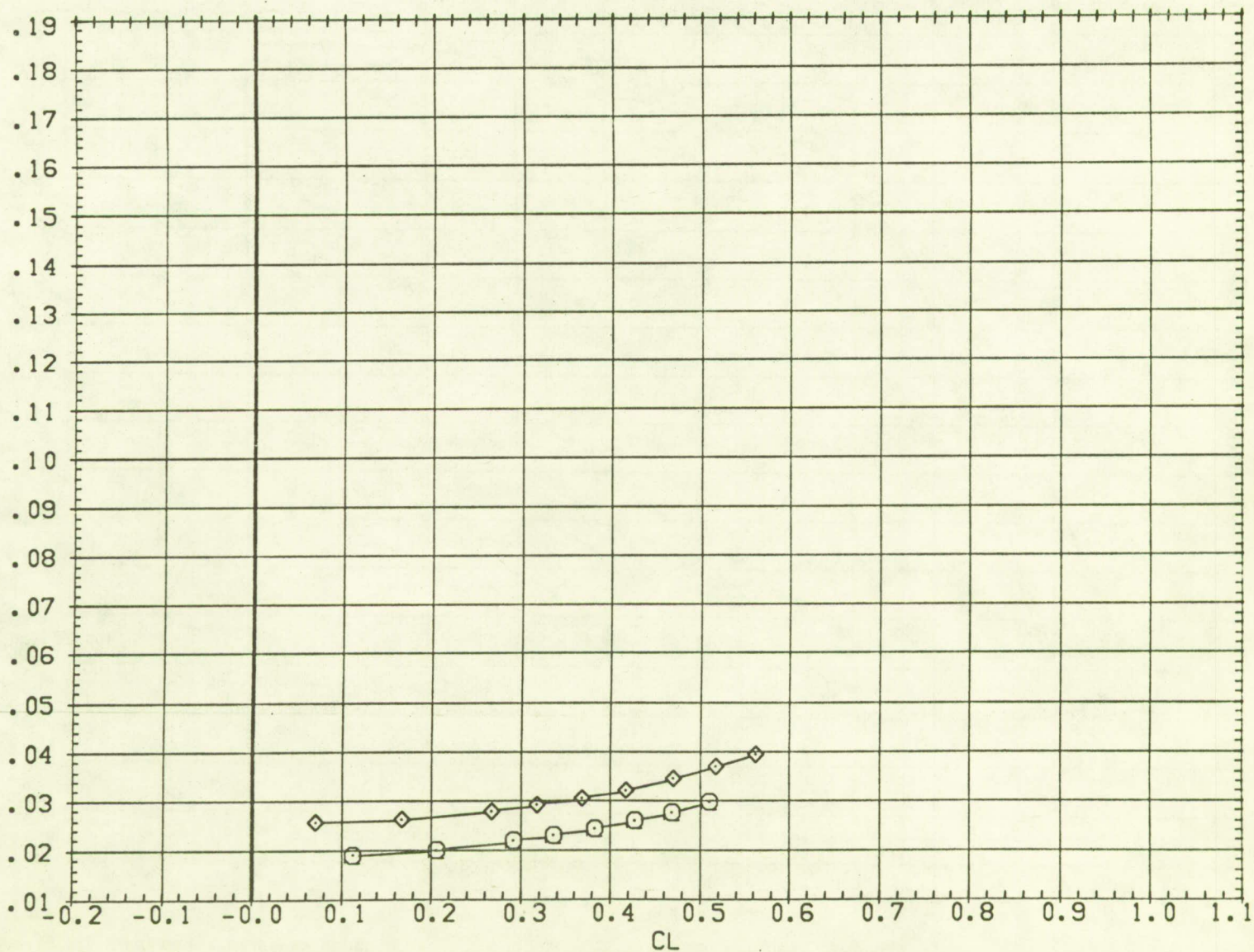

FIG 4 EFFECT OF ADDITION OF MAJOR COMPONENTS ON LONG. AERODYNAMICS. GRIT TYPE 1
 (A)MACH = 0.50

DATA SET SYMBOL CONFIGURATION DESCRIPTION

(HAF024)	○	W1 B1
(RAF007)	△	W1 B1 V1 H1
(RAF013)	◇	W1 B1 V1 H1 K1 N1 K2 N2 ZF1

BETA	HORIZT	SPLR-L	TRANS
0.000		0.000	1.000
0.000	-1.000	0.000	1.000
0.000	-1.000	0.000	1.000

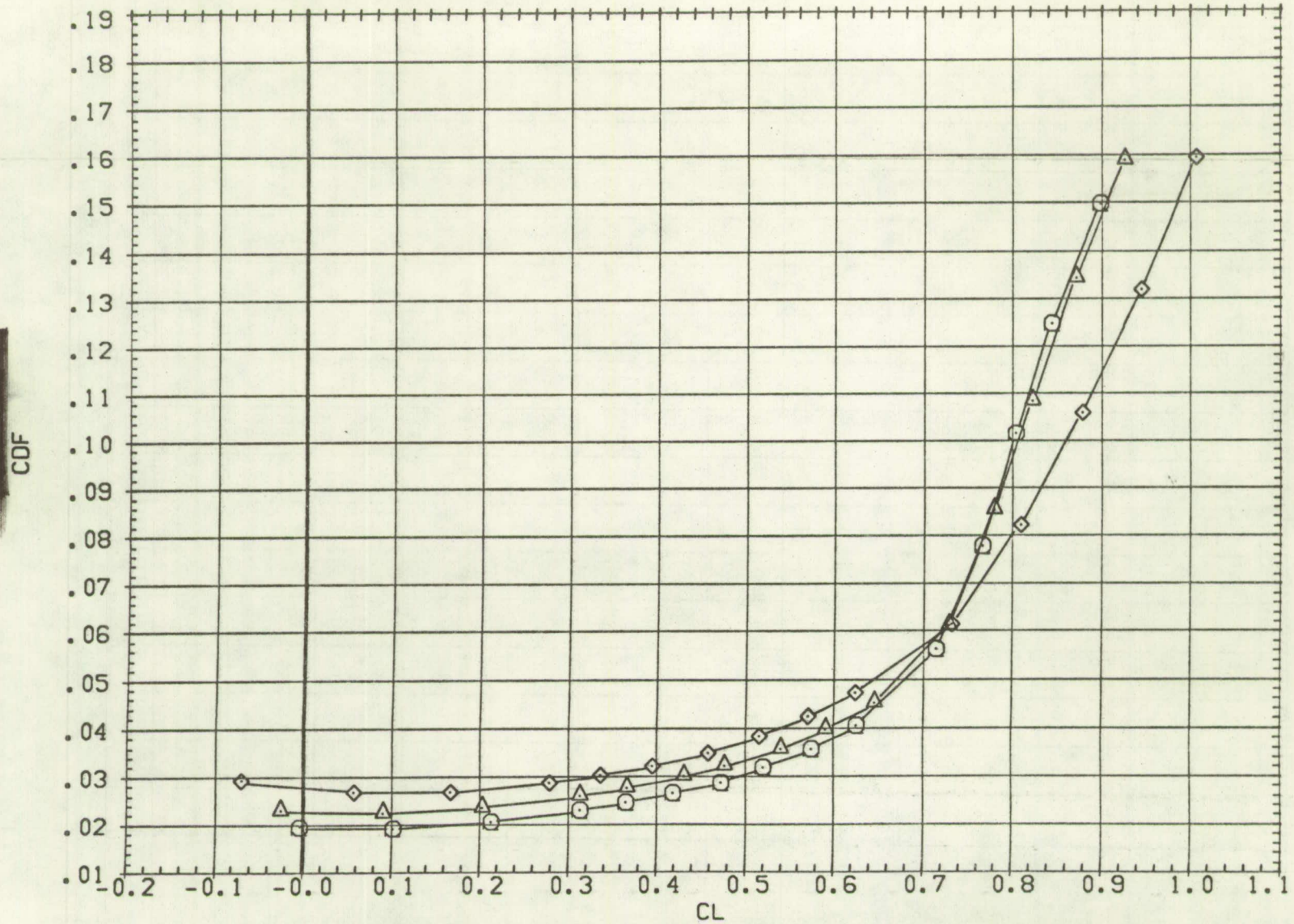

FIG 4 EFFECT OF ADDITION OF MAJOR COMPONENTS ON LONG. AERODYNAMICS. GRIT TYPE 1
 (B)MACH = 0.80

DATA SET SYMBOL	CONFIGURATION DESCRIPTION
(HAF024)	W1 B1
(RAF007)	W1 B1 V1 H1
(RAF013)	W1 B1 V1 H1 K1 N1 K2 N2 ZF1

BETA	HORIZT	SPLR-L	TRANS
0.000		0.000	1.000
0.000	-1.000	0.000	1.000
0.000	-1.000	0.000	1.000

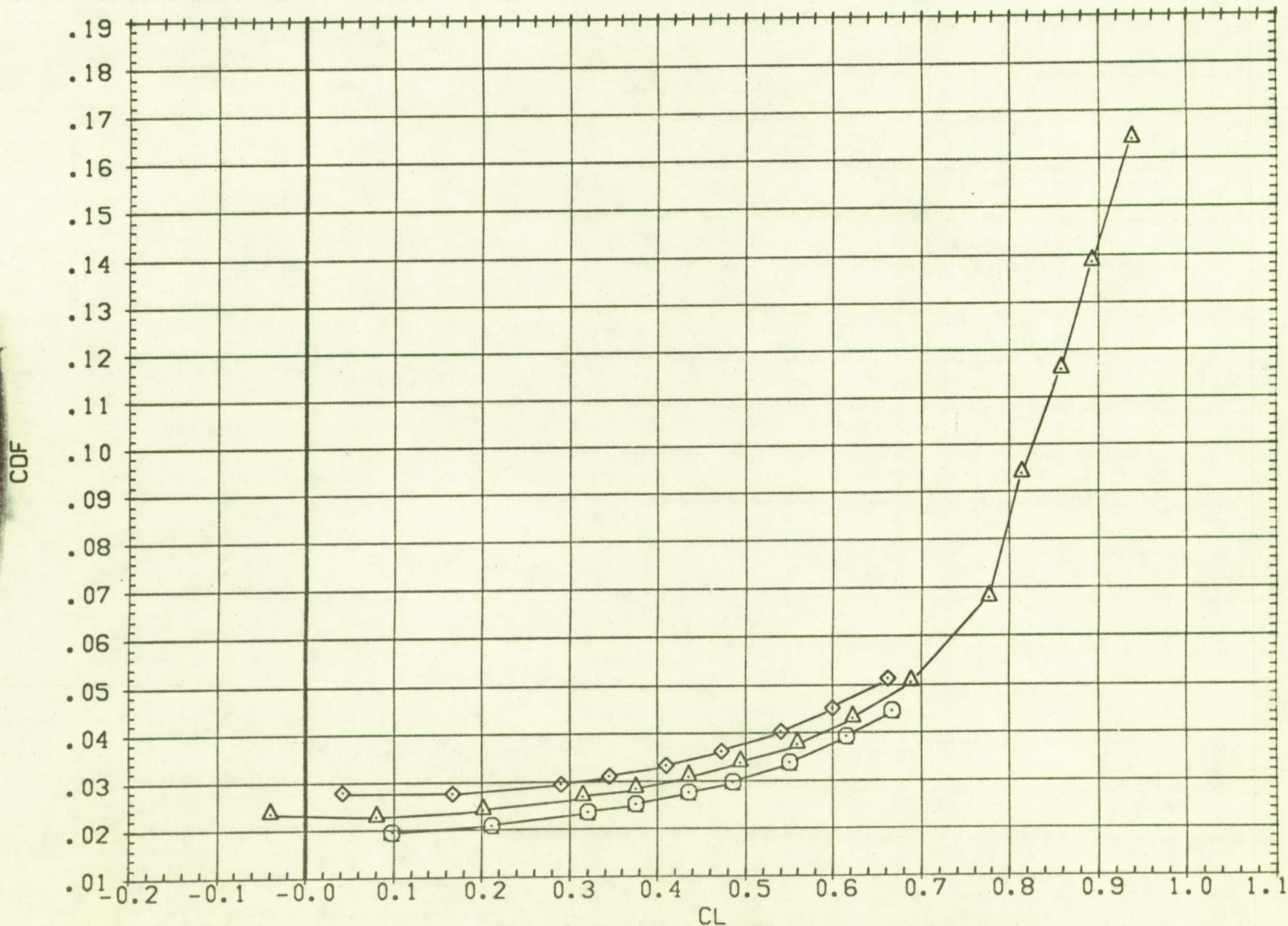

FIG 4 EFFECT OF ADDITION OF MAJOR COMPONENTS ON LONG. AERODYNAMICS. GRIT TYPE 1

DATA SET SYMBOL CONFIGURATION DESCRIPTION
 (HAF024) ○ W1 B1
 (RAF007) △ W1 B1 V1 H1
 (RAF013) ◇ W1 B1 V1 H1 K1 N1 K2 N2 ZF1

BETA	HORIZT	SPLR-L	TRANS
0.000		0.000	1.000
0.000	-1.000	0.000	1.000
0.000	-1.000	0.000	1.000

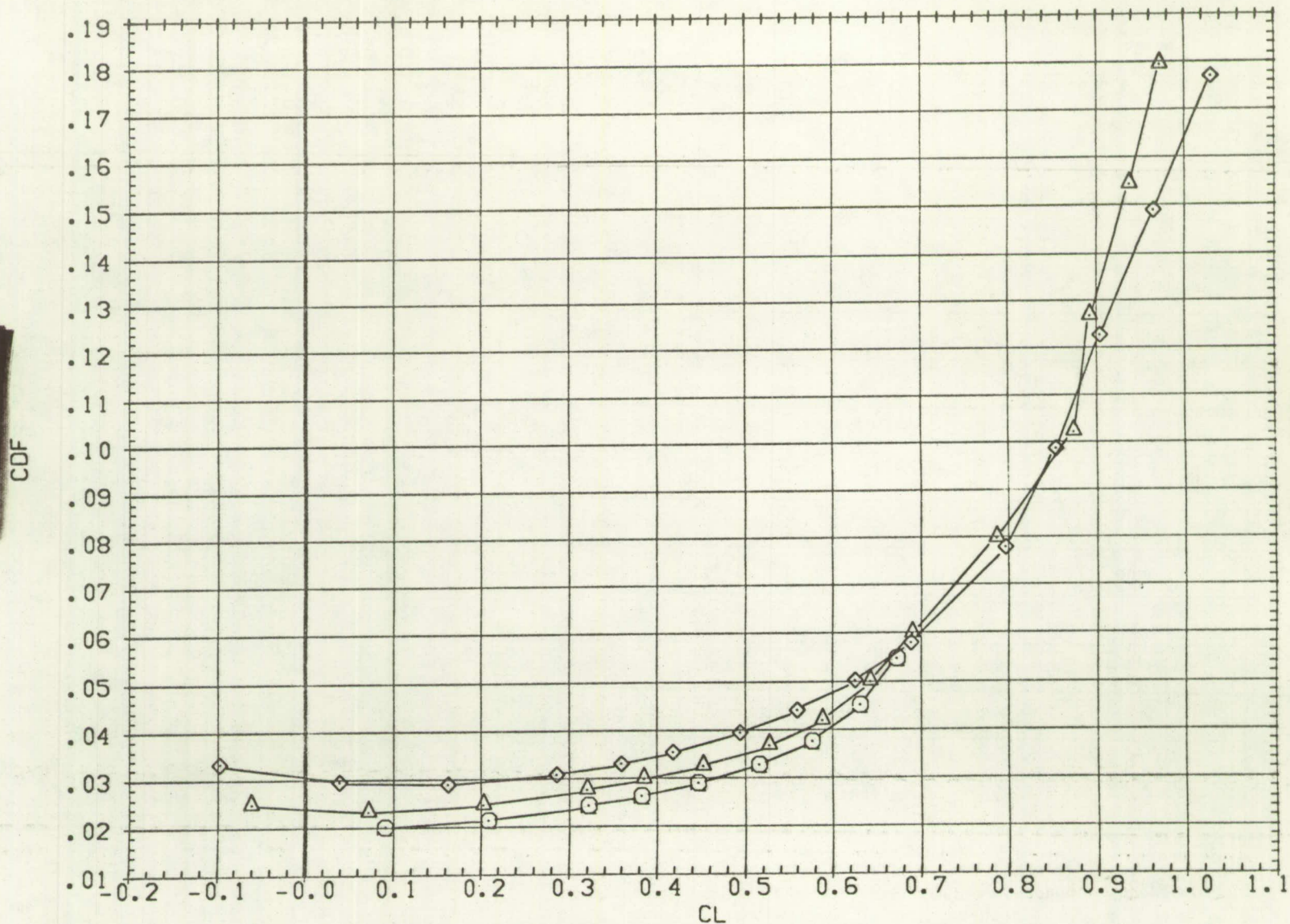

FIG 4 EFFECT OF ADDITION OF MAJOR COMPONENTS ON LONG. AERODYNAMICS. GRIT TYPE 1
 (D)MACH = 0.90

DATA SET SYMBOL CONFIGURATION DESCRIPTION

(HAF024)	○	W1 B1
(RAF007)	△	W1 B1 V1 H1
(RAF013)	◇	W1 B1 V1 H1 K1 N1 K2 N2 ZF1

BETA	HORIZT	SPLR-L	TRANS
0.000		0.000	1.000
0.000	-1.000	0.000	1.000
0.000	-1.000	0.000	1.000

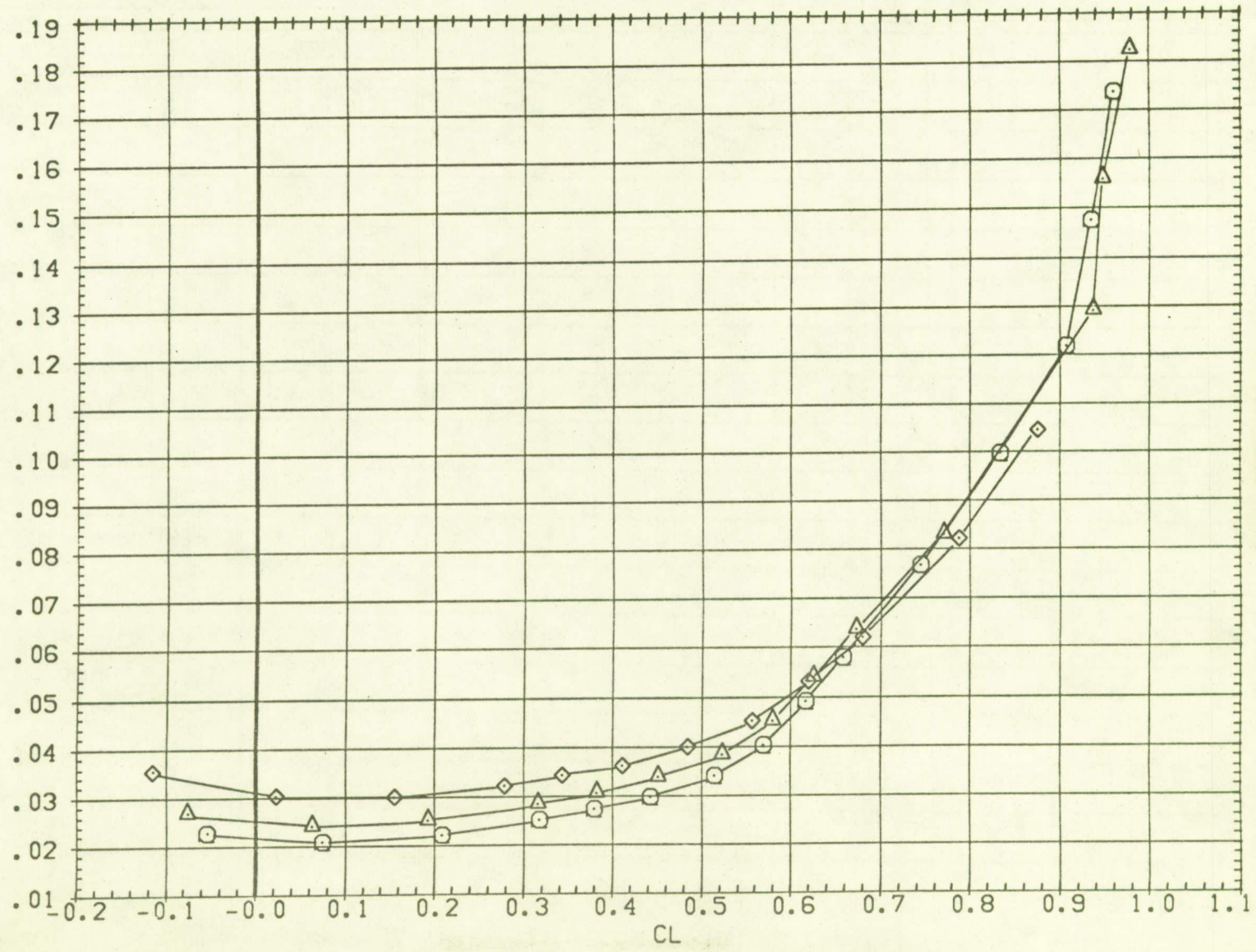

FIG 4 EFFECT OF ADDITION OF MAJOR COMPONENTS ON LONG. AERODYNAMICS. GRIT TYPE 1

(E)MACH = 0.92

DATA SET SYMBOL CONFIGURATION DESCRIPTION
 (HAFO24) ○ W1 B1
 (RAFO07) △ W1 B1 V1 H1
 (RAFO13) ◇ W1 B1 V1 H1 K1 N1 K2 N2 ZF1

BETA	HORIZT	SPLR-L	TRANS
0.000		0.000	1.000
0.000	-1.000	0.000	1.000
0.000	-1.000	0.000	1.000

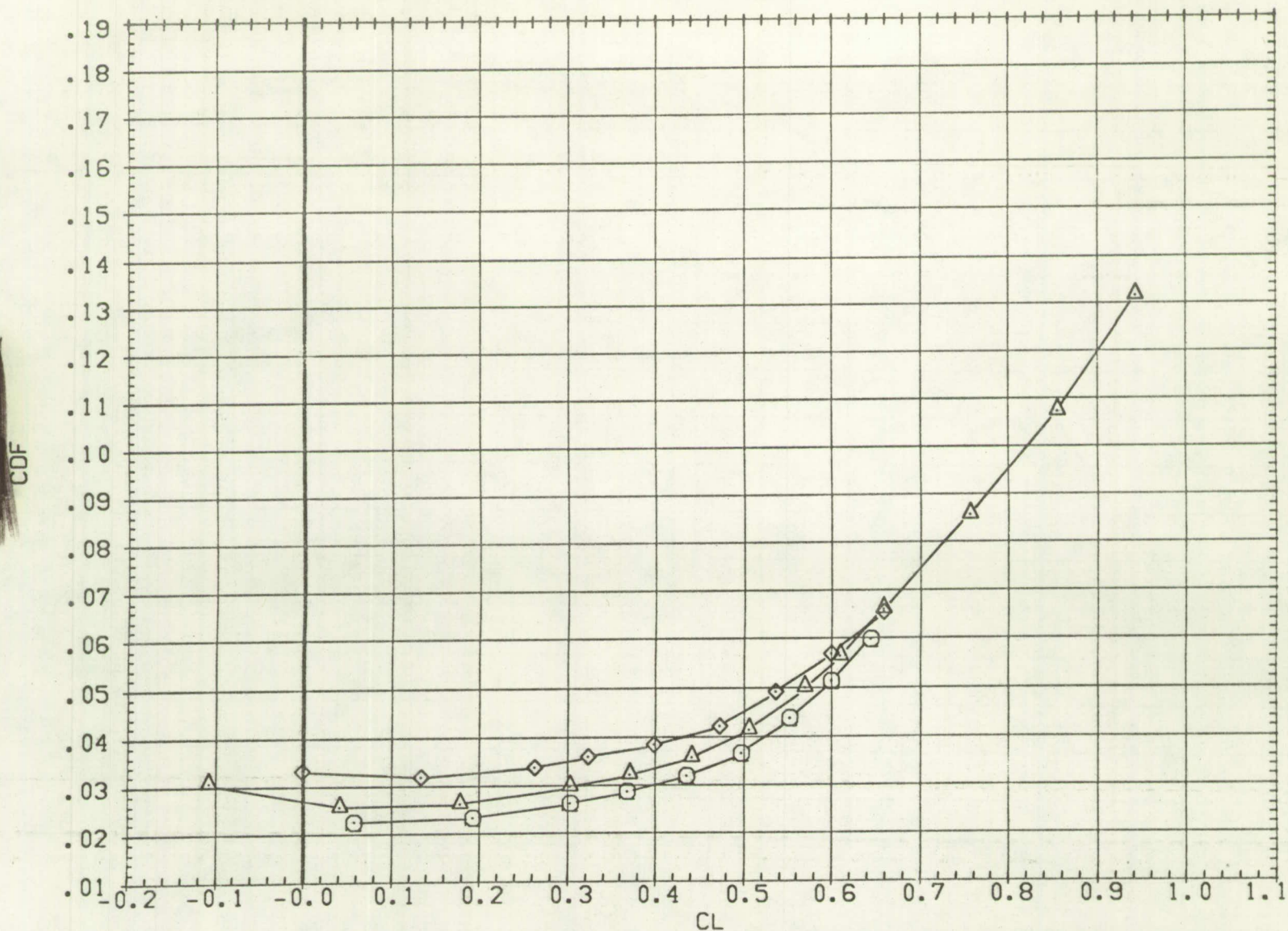

FIG 4 EFFECT OF ADDITION OF MAJOR COMPONENTS ON LONG. AERODYNAMICS. GRIT TYPE 1
 (F)MACH = 0.94

DATA SET SYMBOL	CONFIGURATION DESCRIPTION
(HAF024)	W1 B1
(RAF007)	W1 B1 V1 H1
(RAF013)	W1 B1 V1 H1 K1 N1 K2 N2 ZF1

BETA	HORIZT	SPLR-L	TRANS
0.000		0.000	1.000
0.000	-1.000	0.000	1.000
0.000	-1.000	0.000	1.000

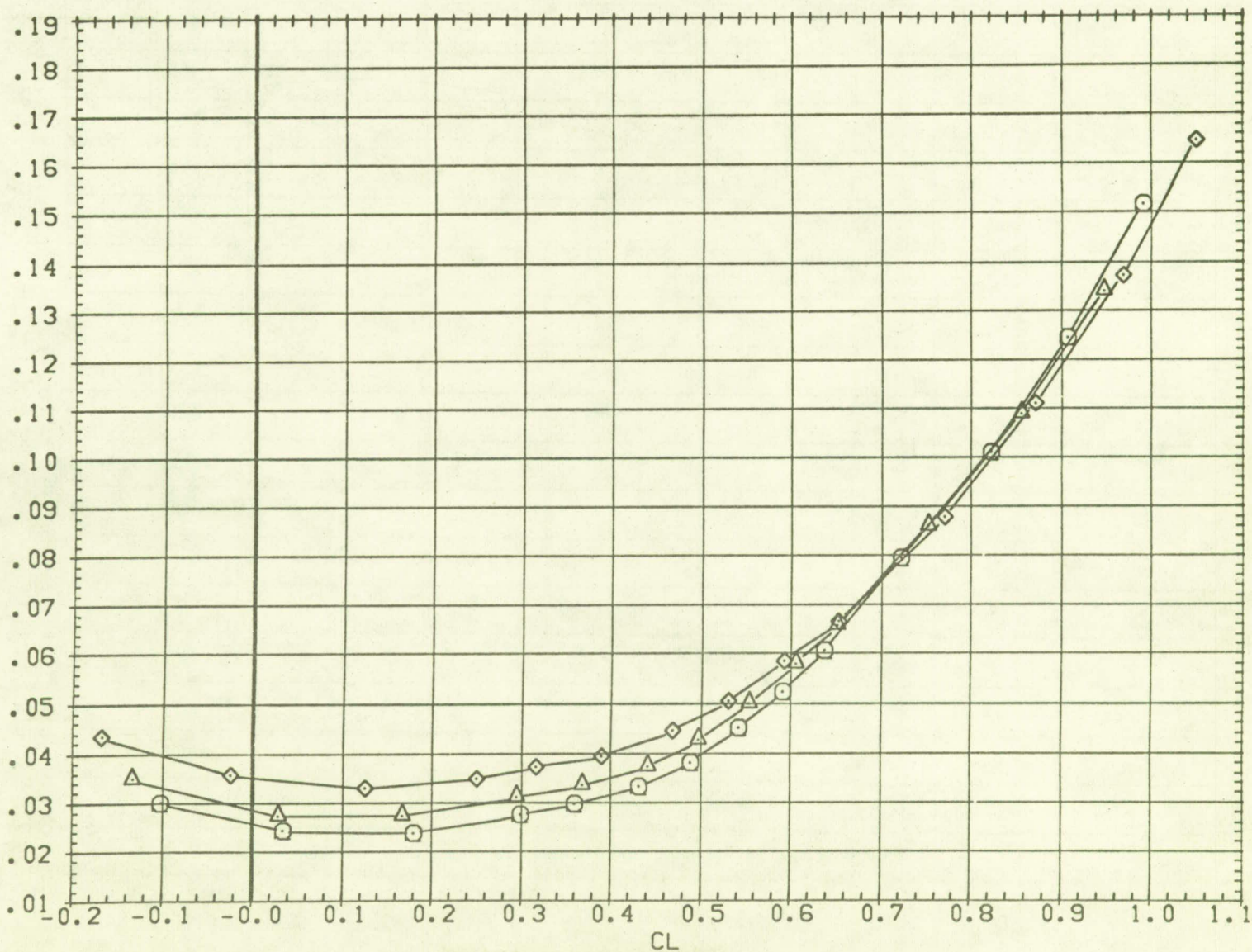

FIG 4 EFFECT OF ADDITION OF MAJOR COMPONENTS ON LONG. AERODYNAMICS. GRIT TYPE 1
 (G)MACH = 0.95

DATA SET SYMBOL CONFIGURATION DESCRIPTION
 (HAF024) ○ W1 B1
 (RAF007) △ W1 B1 V1 H1
 (RAF013) ◇ DATA NOT AVAILABLE

BETA	HORIZT	SPLR-L	TRANS
0.000		0.000	1.000
0.000	-1.000	0.000	1.000
0.000	-1.000	0.000	1.000

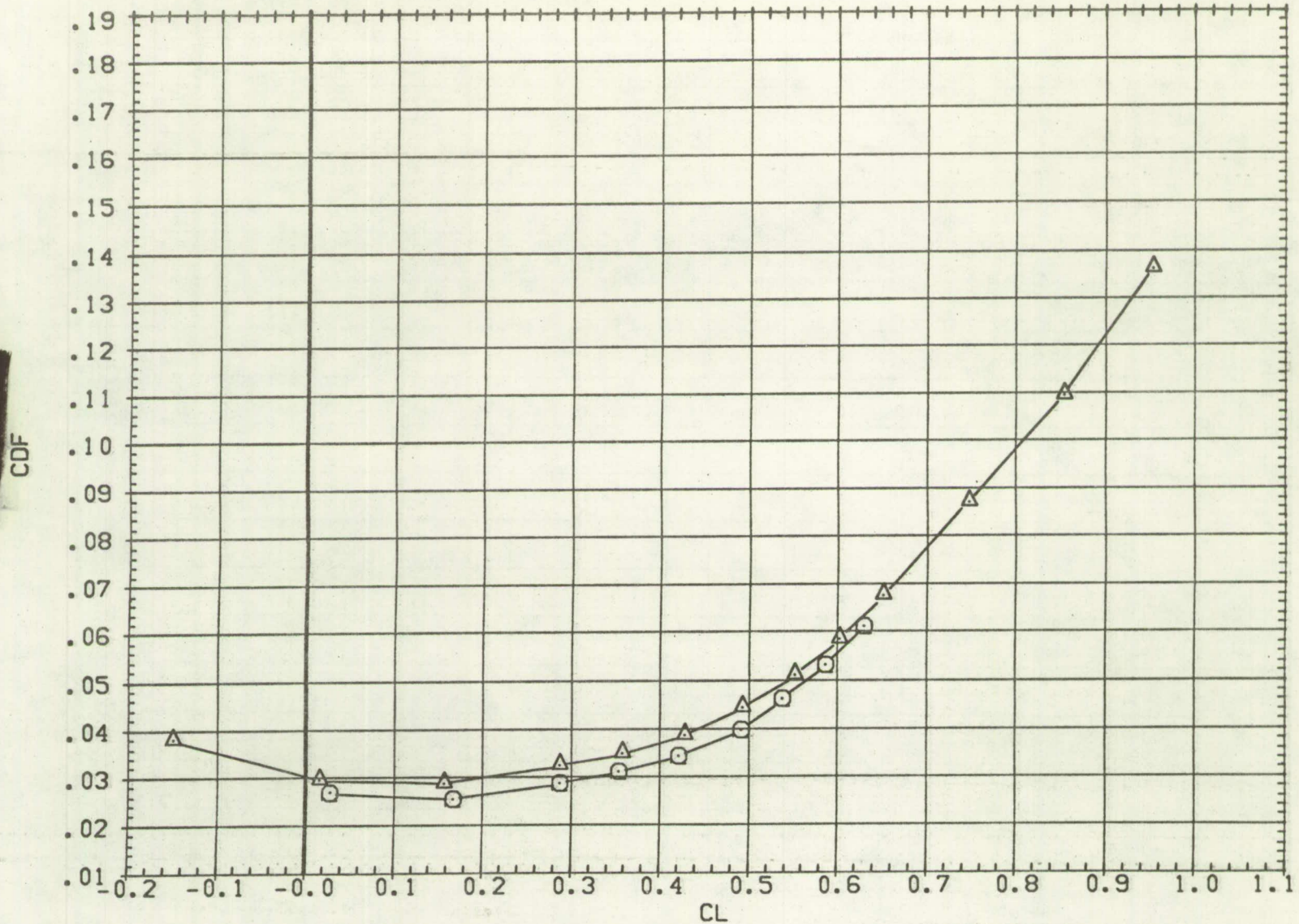

FIG 4 EFFECT OF ADDITION OF MAJOR COMPONENTS ON LONG. AERODYNAMICS. GRIT TYPE 1
 (H)MACH = 0.96

DATA SET SYMBOL	CONFIGURATION DESCRIPTION
(RAFD10) ○	W1 B1 V1 H1
(RAFD11) △	W1 B1 V1 H1 K1 N1 K2 N2 ZF1

BETA	HORIZT	SPLR-L	TRANS
0.000	-1.000	0.000	2.000
0.000	-1.000	0.000	2.000

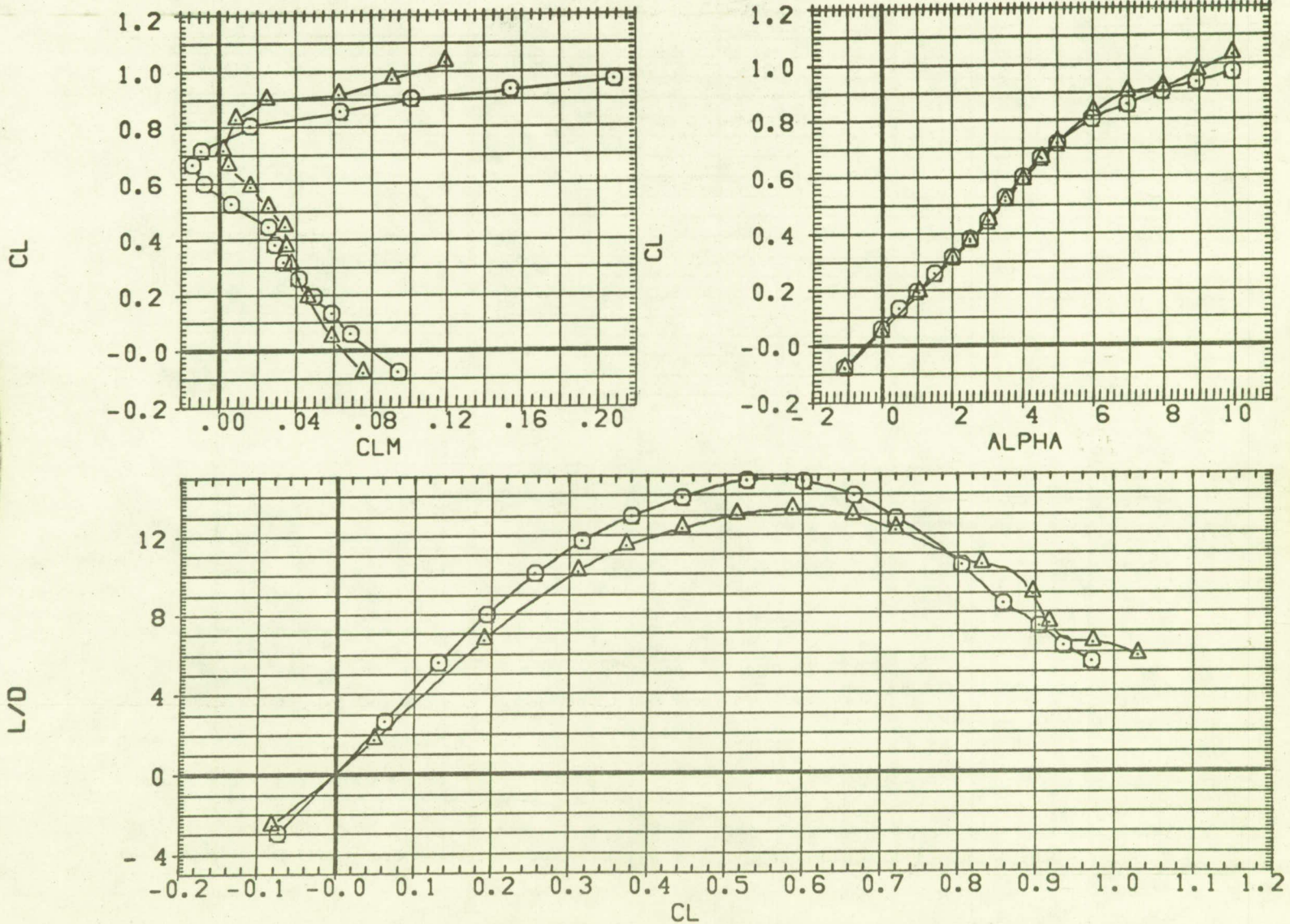

FIG 5 EFFECT OF ADDITION OF MAJOR COMPONENTS ON LONG. AERODYNAMICS. GRIT TYPE 2
 (A)MACH = 0.90

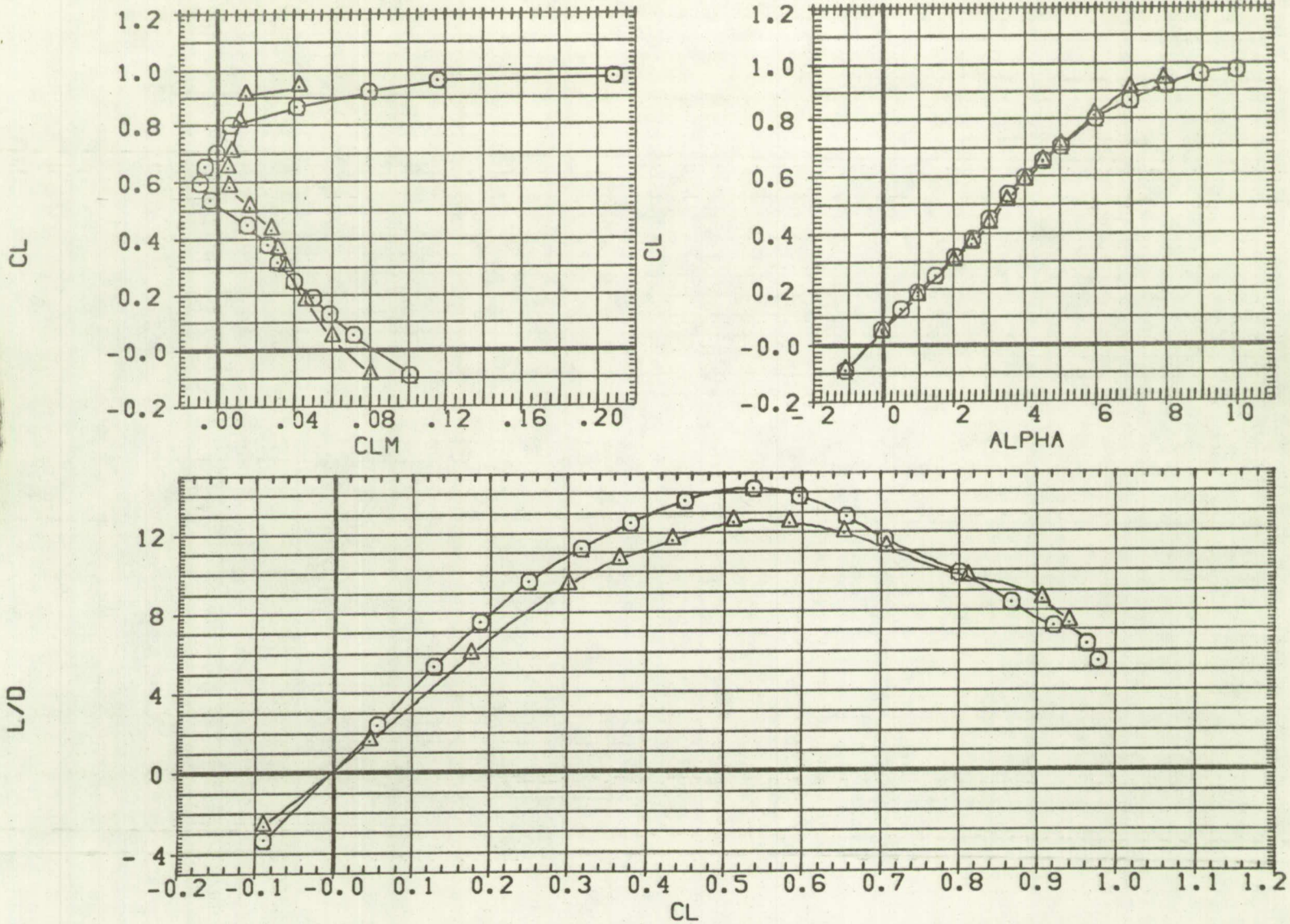

FIG 5 EFFECT OF ADDITION OF MAJOR COMPONENTS ON LONG. AERODYNAMICS. GRIT TYPE 2
 (B)MACH = 0.92

DATA SET SYMBOL CONFIGURATION DESCRIPTION
 (RAFO10) \bigcirc W1 B1 V1 H1
 (RAFO11) \triangle W1 B1 V1 H1 K1 N1 K2 N2 ZF1

BETA	HORIZT	SPLR-L	TRANS
0.000	-1.000	0.000	2.000
0.000	-1.000	0.000	2.000

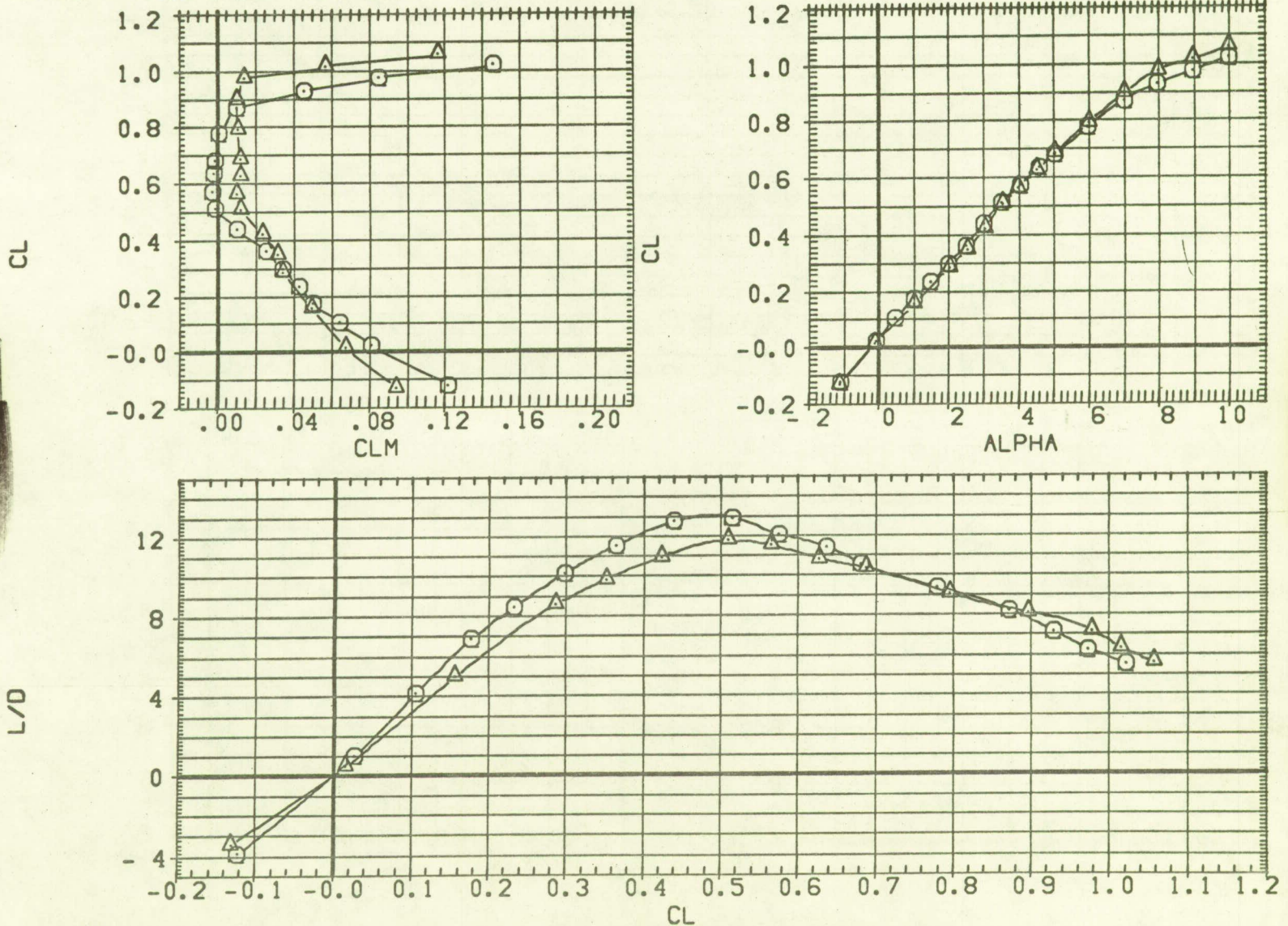

FIG 5 EFFECT OF ADDITION OF MAJOR COMPONENTS ON LONG. AERODYNAMICS. GRIT TYPE 2

(C)MACH = 0.94

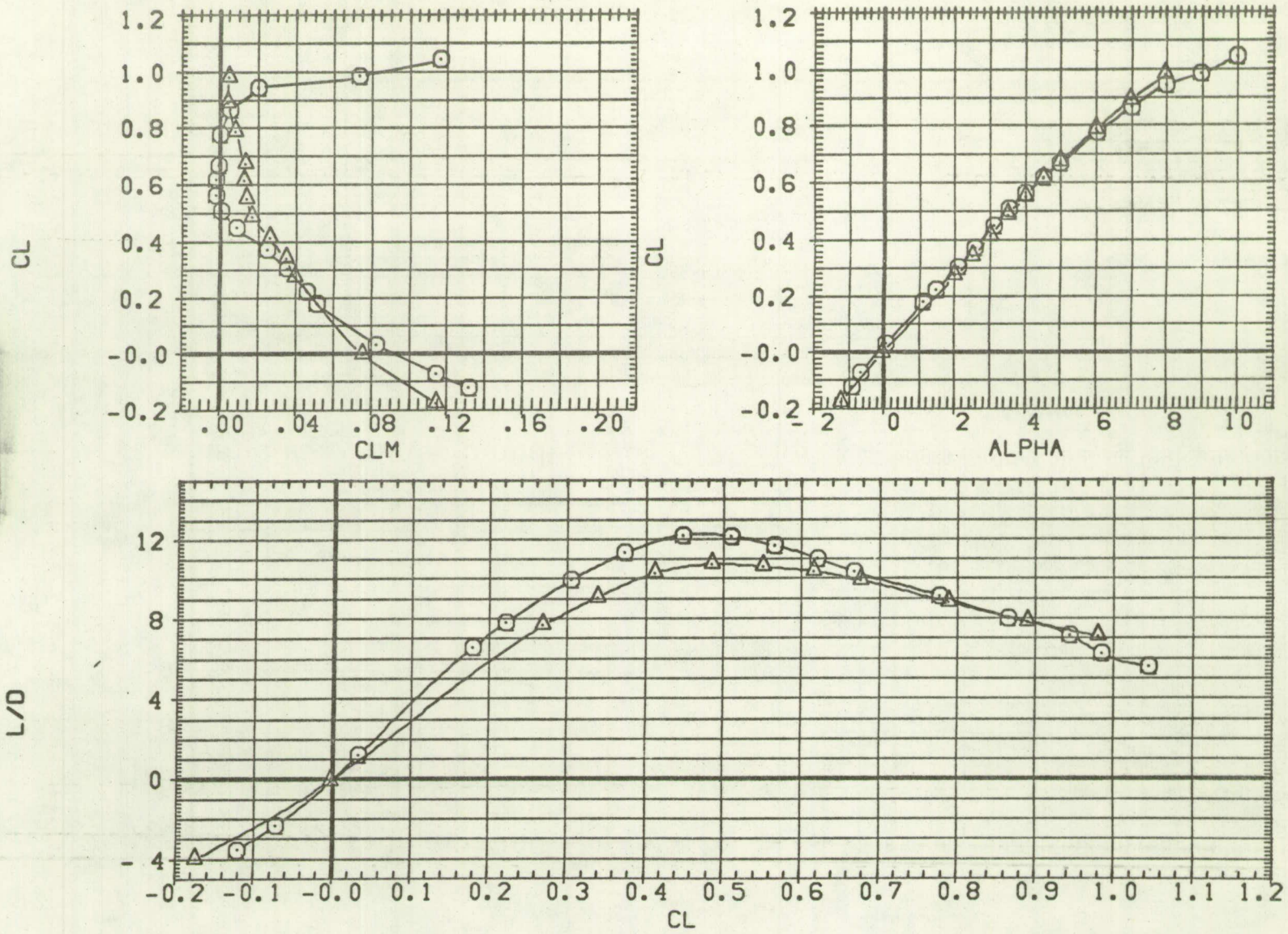

FIG 5 EFFECT OF ADDITION OF MAJOR COMPONENTS ON LONG. AERODYNAMICS. GRIT TYPE 2
 (D)MACH = 0.95 PAGE 20

DATA SET SYMBOL CONFIGURATION DESCRIPTION
 (RAFO10) ○ W1 B1 V1 H1
 (RAFO11) △ W1 B1 V1 H1 K1 N1 K2 N2 ZF1

BETA HORIZT SPLR-L TRANS
 0.000 -1.000 0.000 2.000
 0.000 -1.000 0.000 2.000

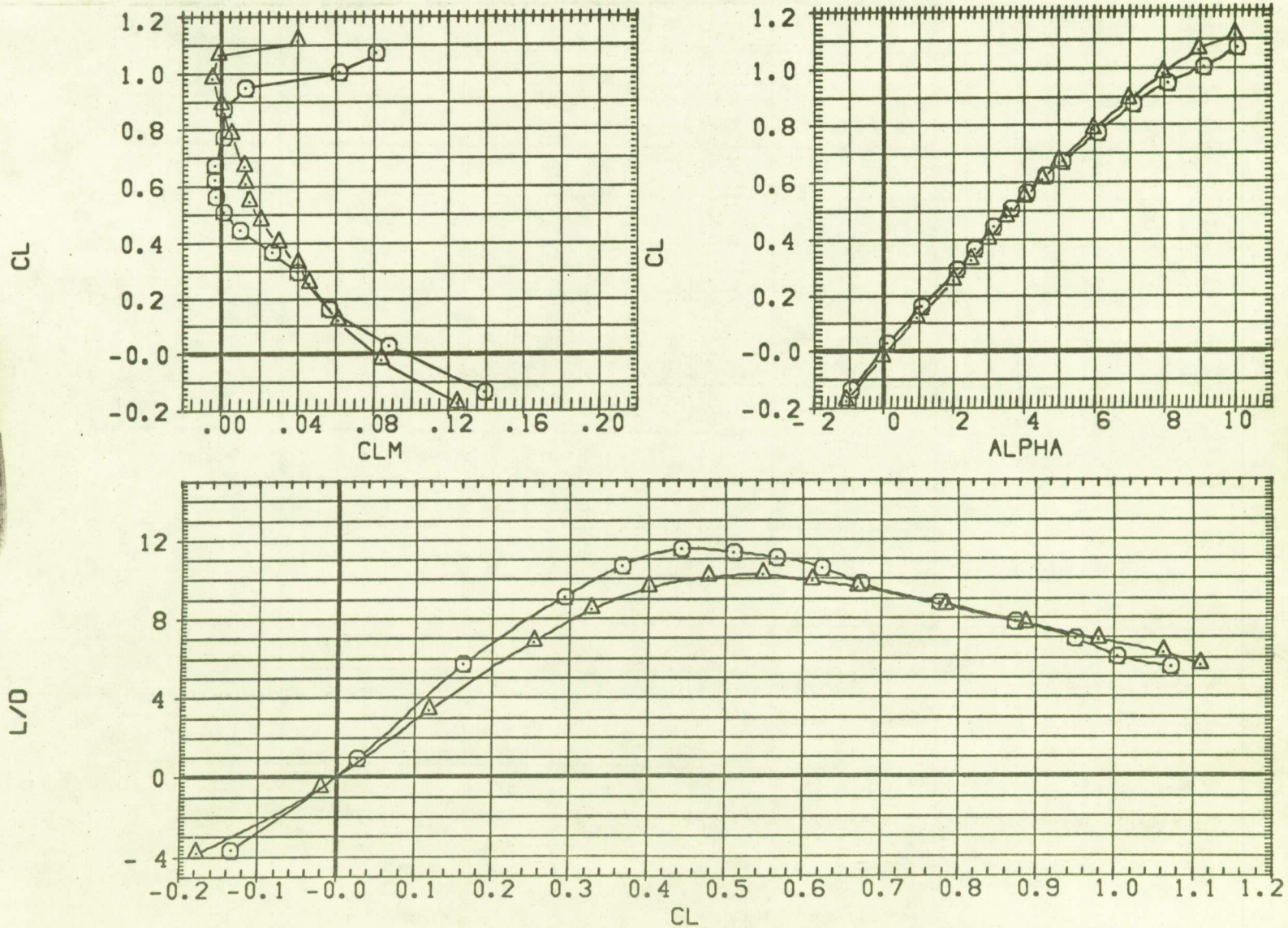

FIG 5 EFFECT OF ADDITION OF MAJOR COMPONENTS ON LONG. AERODYNAMICS. GRIT TYPE 2

(E)MACH = 0.96

DATA SET SYMBOL CONFIGURATION DESCRIPTION
 (RAFO10) W1 B1 V1 H1
 (RAFO11) W1 B1 V1 H1 K1 N1 K2 N2 ZF1

BETA	HORIZT	SPLR-L	TRANS
0.000	-1.000	0.000	2.000
0.000	-1.000	0.000	2.000

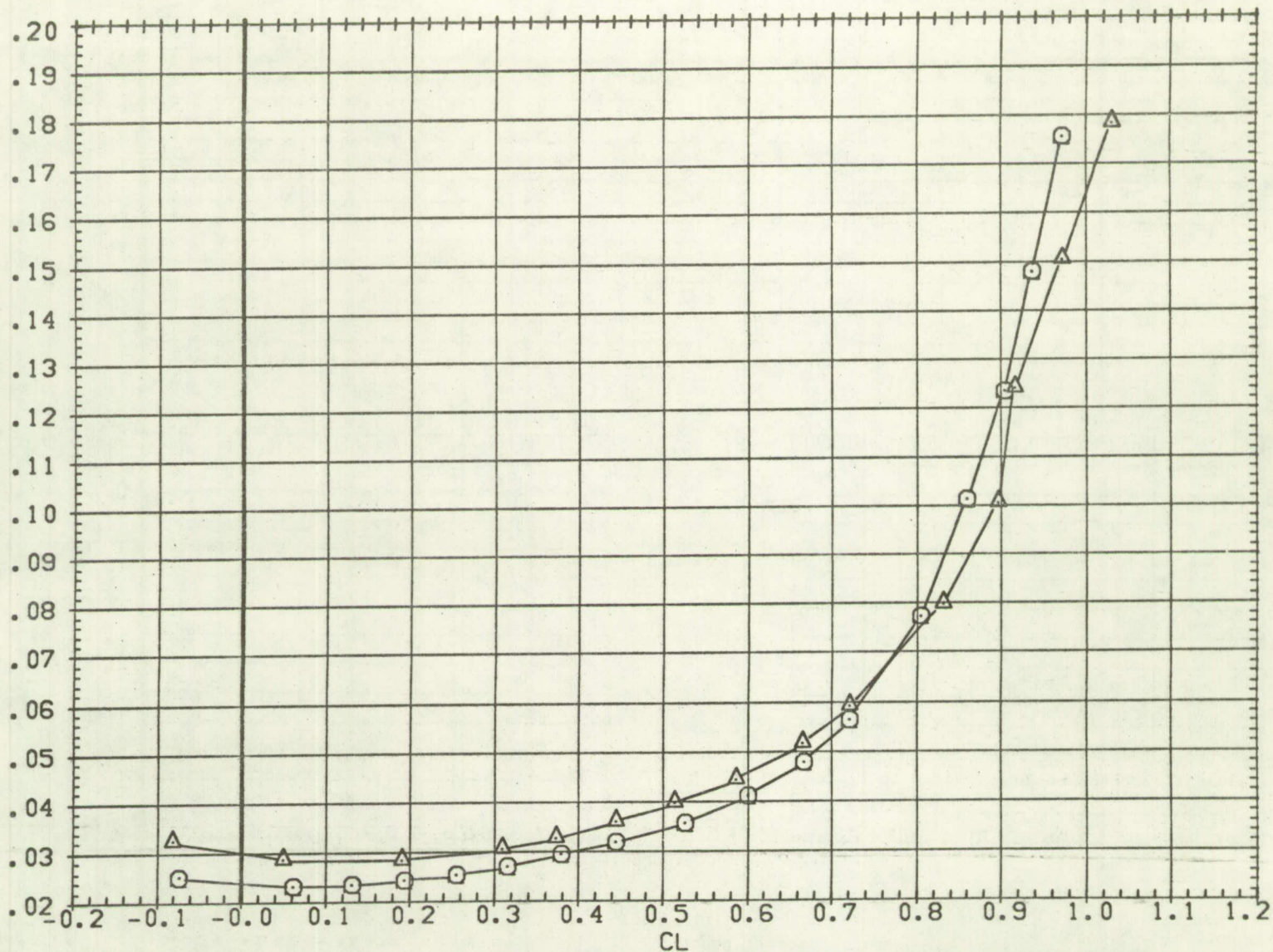



FIG 5 EFFECT OF ADDITION OF MAJOR COMPONENTS ON LONG. AERODYNAMICS. GRIT TYPE 2
 (A)MACH = 0.90

DATA SET SYMBOL CONFIGURATION DESCRIPTION
 (RAFD10)  W1 B1 V1 H1
 (RAFD11)  W1 B1 V1 H1 K1 N1 K2 N2 ZF1

BETA	HORIZT	SPLR-L	TRANS
0.000	-1.000	0.000	2.000
0.000	-1.000	0.000	2.000

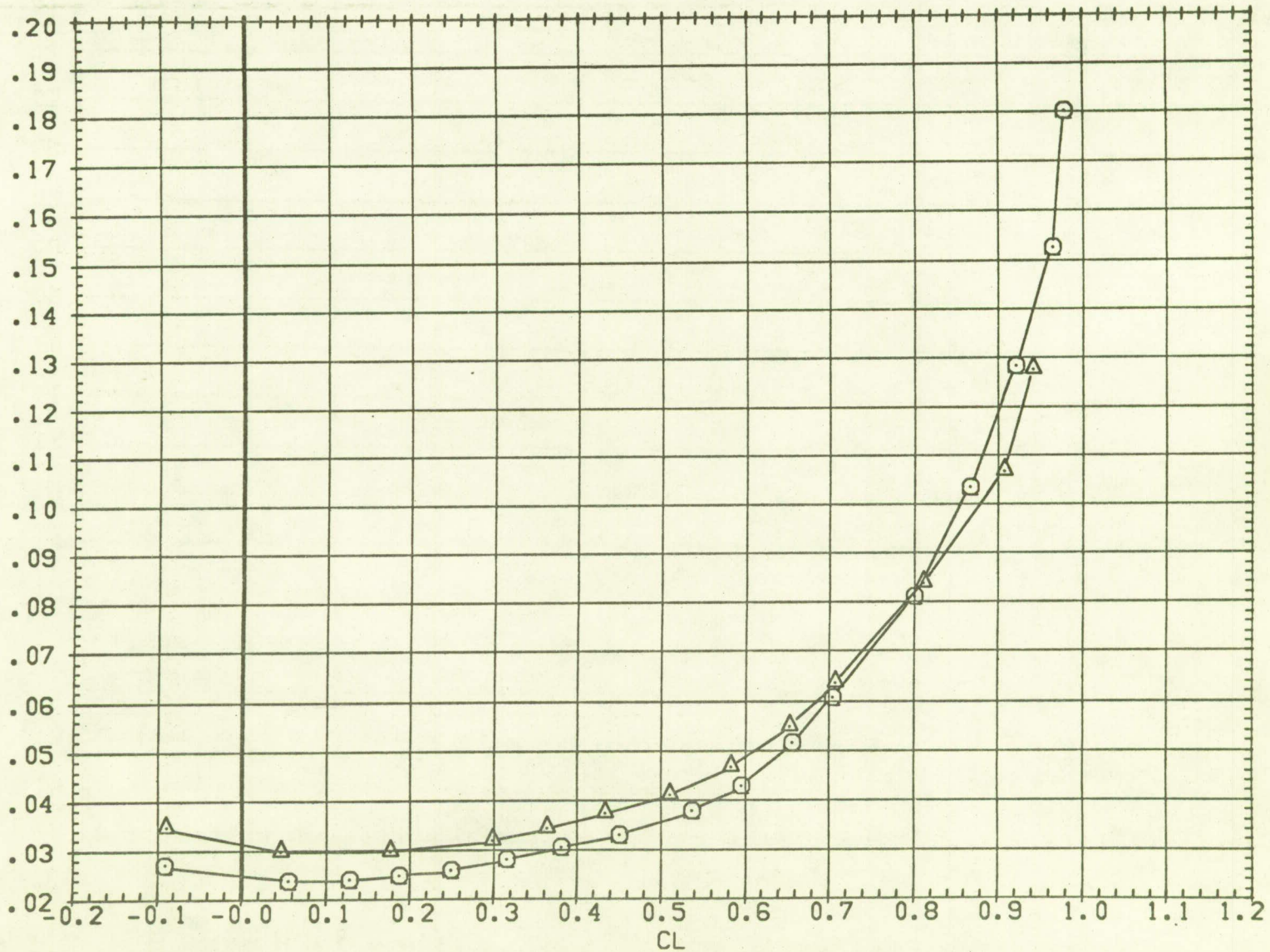

FIG 5 EFFECT OF ADDITION OF MAJOR COMPONENTS ON LONG. AERODYNAMICS. GRIT TYPE 2
 (B)MACH = 0.92

DATA SET SYMBOL CONFIGURATION DESCRIPTION
 (RAFO10) W1 B1 V1 H1
 (RAFO11) W1 B1 V1 H1 K1 N1 K2 N2 ZF1

BETA	HORIZT	SPLR-L	TRANS
0.000	-1.000	0.000	2.000
0.000	-1.000	0.000	2.000

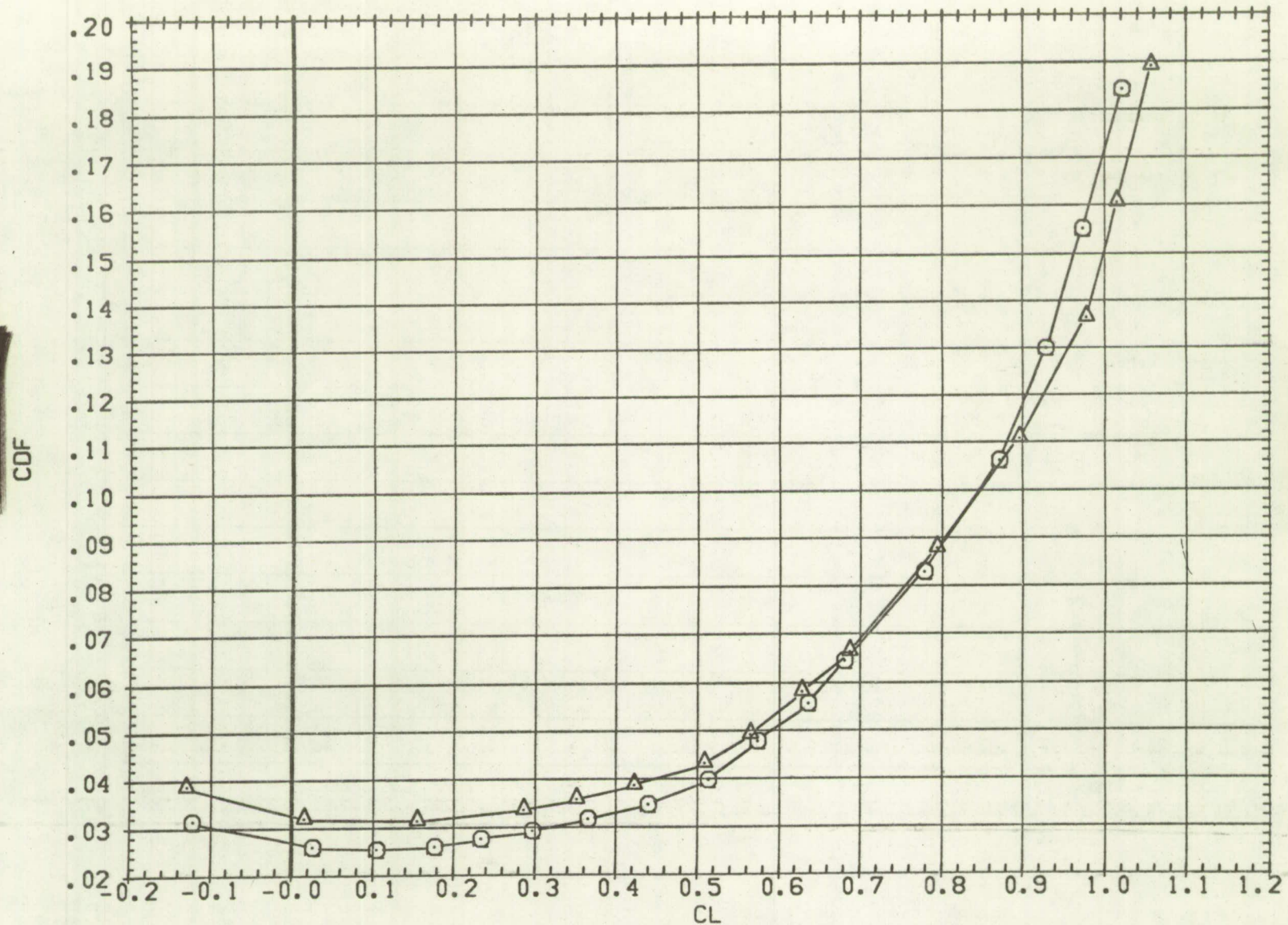



FIG 5 EFFECT OF ADDITION OF MAJOR COMPONENTS ON LONG. AERODYNAMICS. GRIT TYPE 2
 (C)MACH = 0.94

DATA SET SYMBOL CONFIGURATION DESCRIPTION
 (RAFD10)  W1 B1 V1 H1
 (RAFD11)  W1 B1 V1 H1 K1 N1 K2 N2 ZF1

BETA	HORIZT	SPLR-L	TRANS
0.000	-1.000	0.000	2.000
0.000	-1.000	0.000	2.000

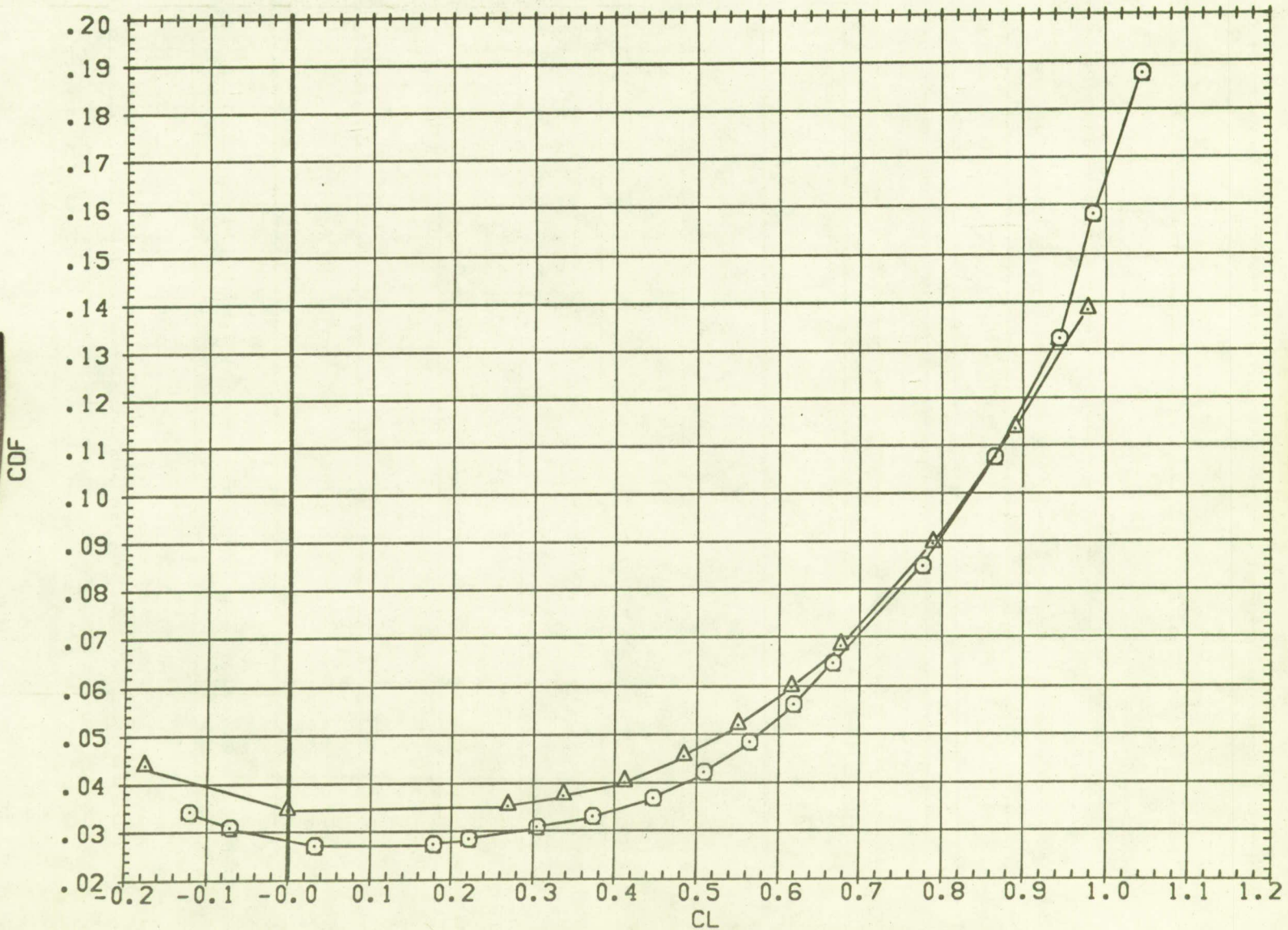

FIG 5 EFFECT OF ADDITION OF MAJOR COMPONENTS ON LONG. AERODYNAMICS. GRIT TYPE 2

(M)MACH = 0.95

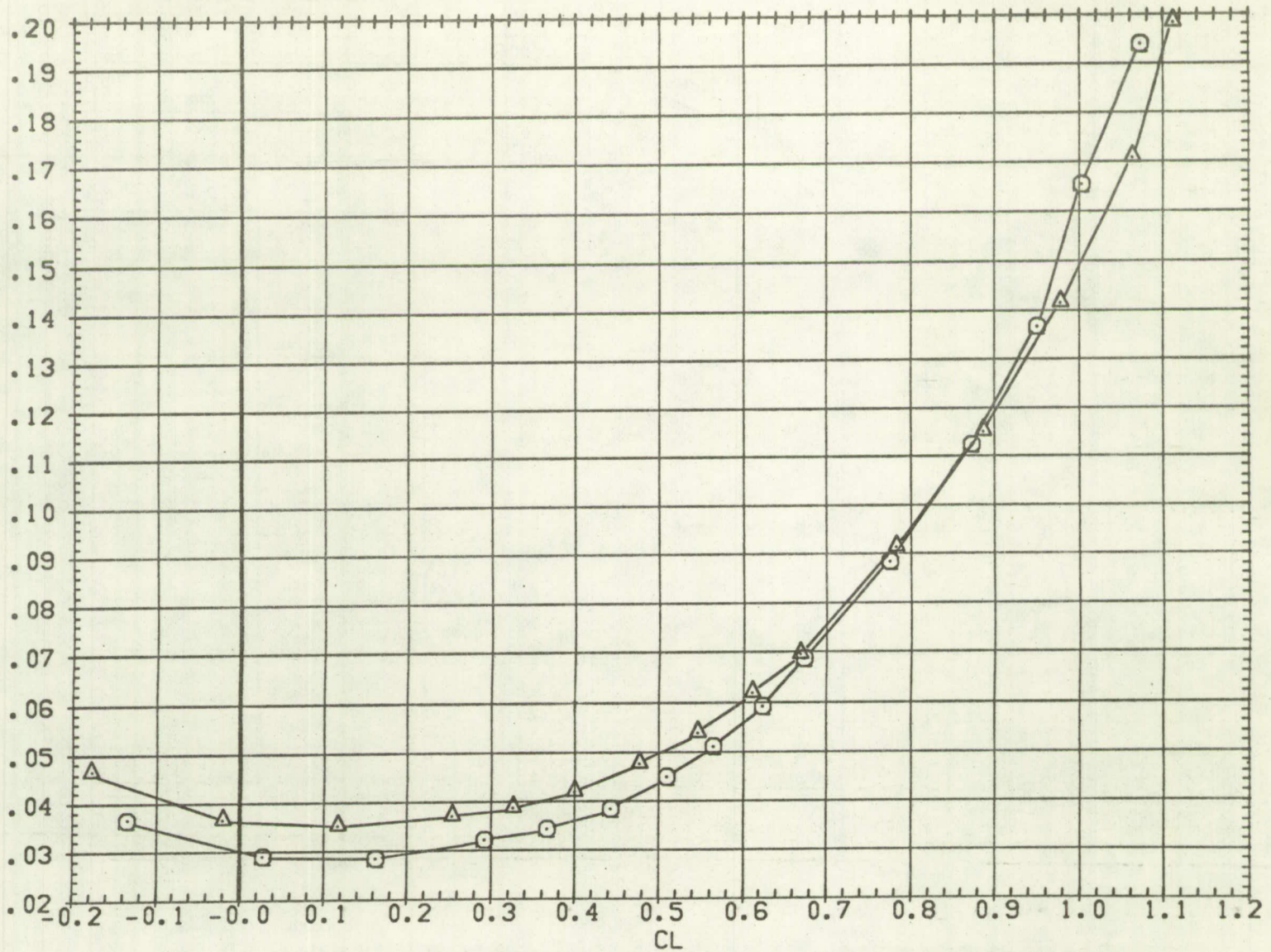

FIG 5 EFFECT OF ADDITION OF MAJOR COMPONENTS ON LONG. AERODYNAMICS. GRIT TYPE 2
 (E)MACH = 0.96

DATA SET SYMBOL CONFIGURATION DESCRIPTION
 (RAF025) ○ W1 B1
 (RAF009) △ W1 B1 V1 H1
 (RAF015) ◇ W1 B1 V1 H1 K1 N1 K2 N2 ZF1

ALPHA HORIZT SPLR-L TRANS
 3.400 -1.000 0.000 1.000
 3.400 -1.000 0.000 1.000
 3.400 -1.000 0.000 1.000

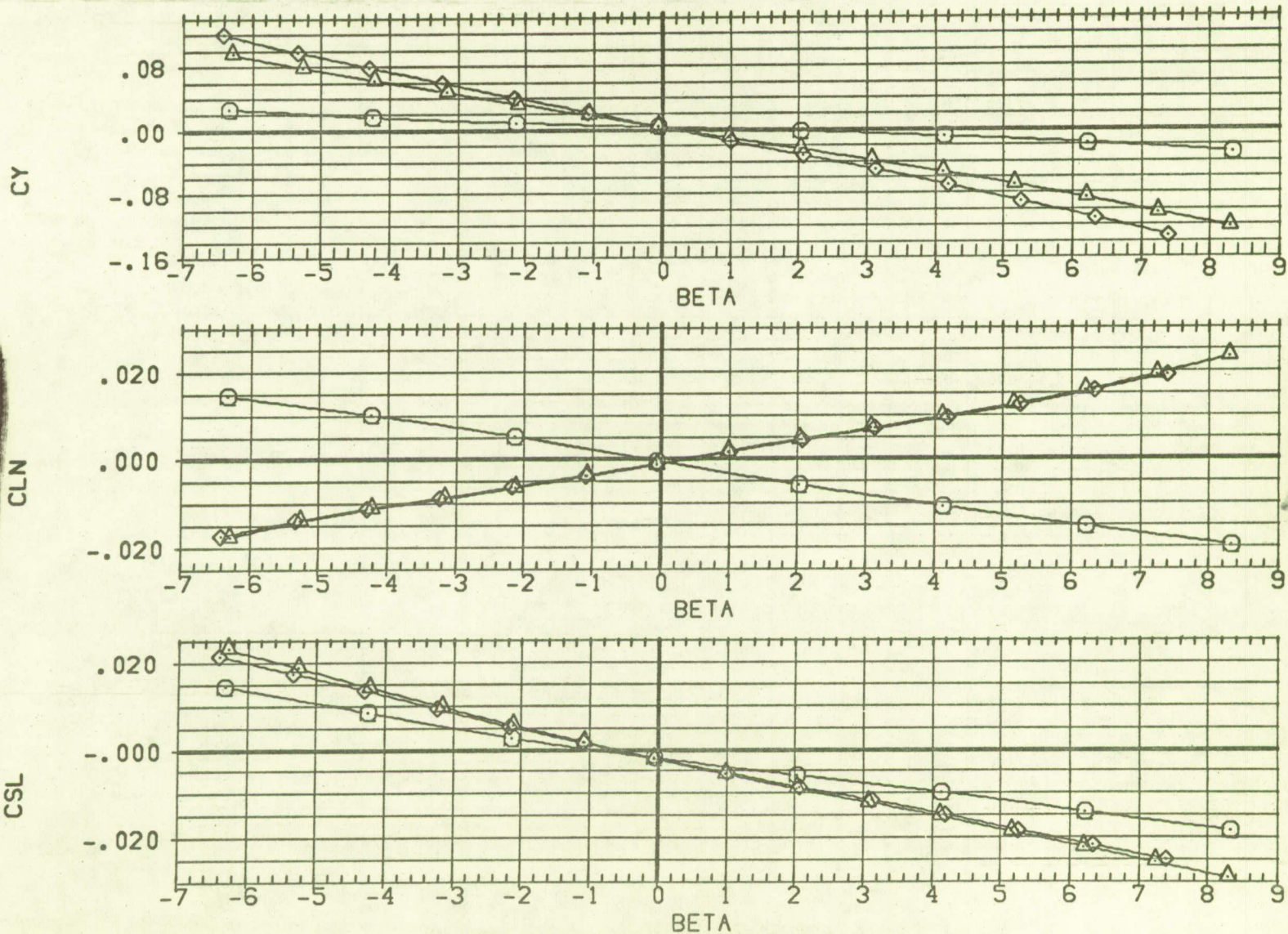

FIG 6 EFFECT OF ADDITION OF MAJOR COMPONENTS ON LAT-DIR AERODYN. IN SIDESLIP

(A)MACH = 0.80

DATA SET SYMBOL	CONFIGURATION DESCRIPTION
(RAF025)	W1 B1
(RAF009)	W1 B1 V1 H1
(RAF015)	W1 B1 V1 H1 K1 N1 K2 N2 ZF1

ALPHA	HORIZT	SPLR-L	TRANS
3.400		0.000	1.000
3.400	-1.000	0.000	1.000
3.400	-1.000	0.000	1.000

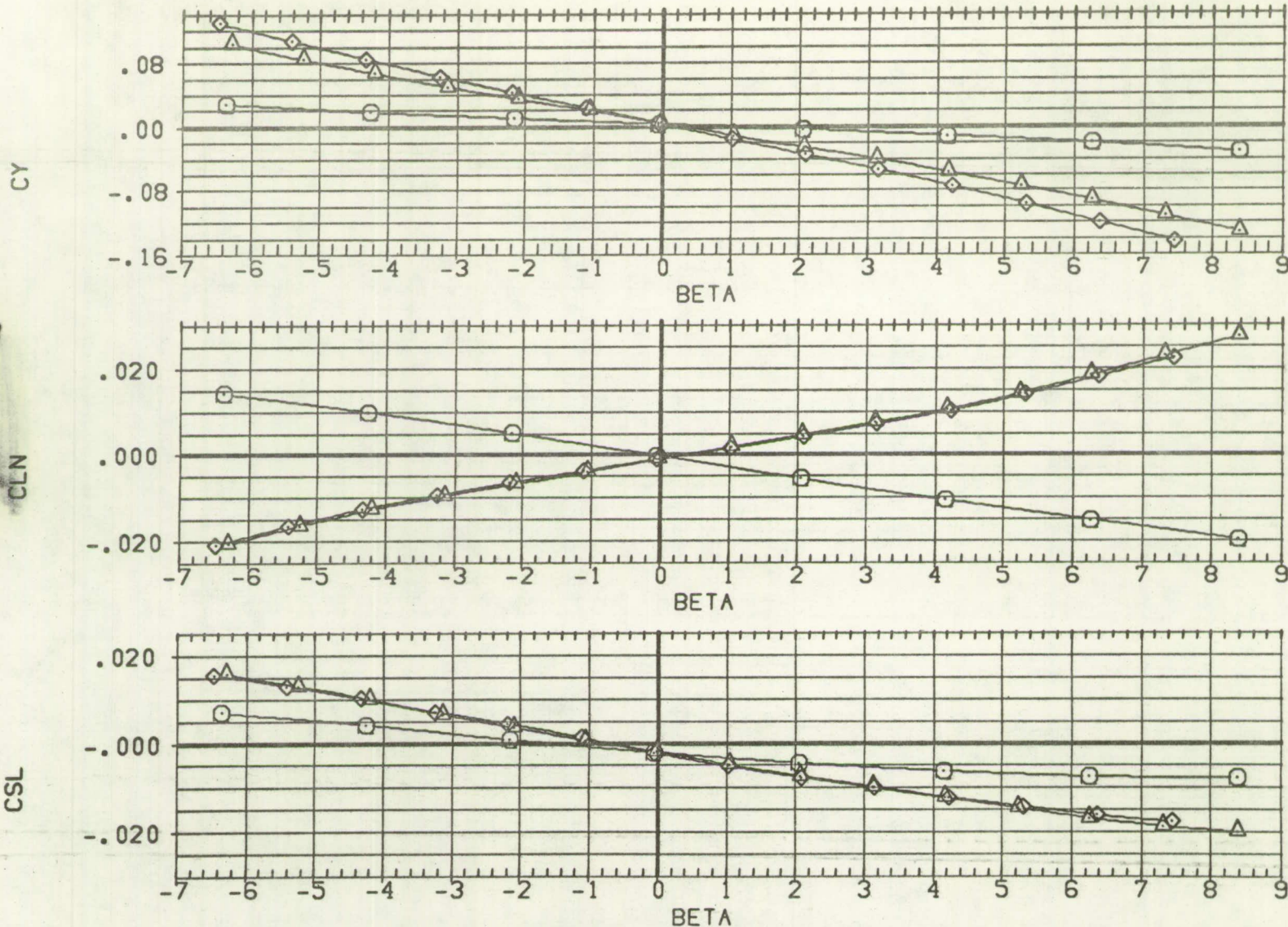

FIG 6 EFFECT OF ADDITION OF MAJOR COMPONENTS ON LAT-DIR AERODYN. IN SIDESLIP
 (B)MACH = 0.95

DATA SET SYMBOL CONFIGURATION DESCRIPTION
 (RAFD08) \circ W1 B1 V1 H1
 (RAFD14) \triangle W1 B1 V1 H1 K1 N1 K2 N2 ZF1

BETA HORIZT SPLR-L TRANS
 3.000 -1.000 0.000 1.000
 3.000 -1.000 0.000 1.000

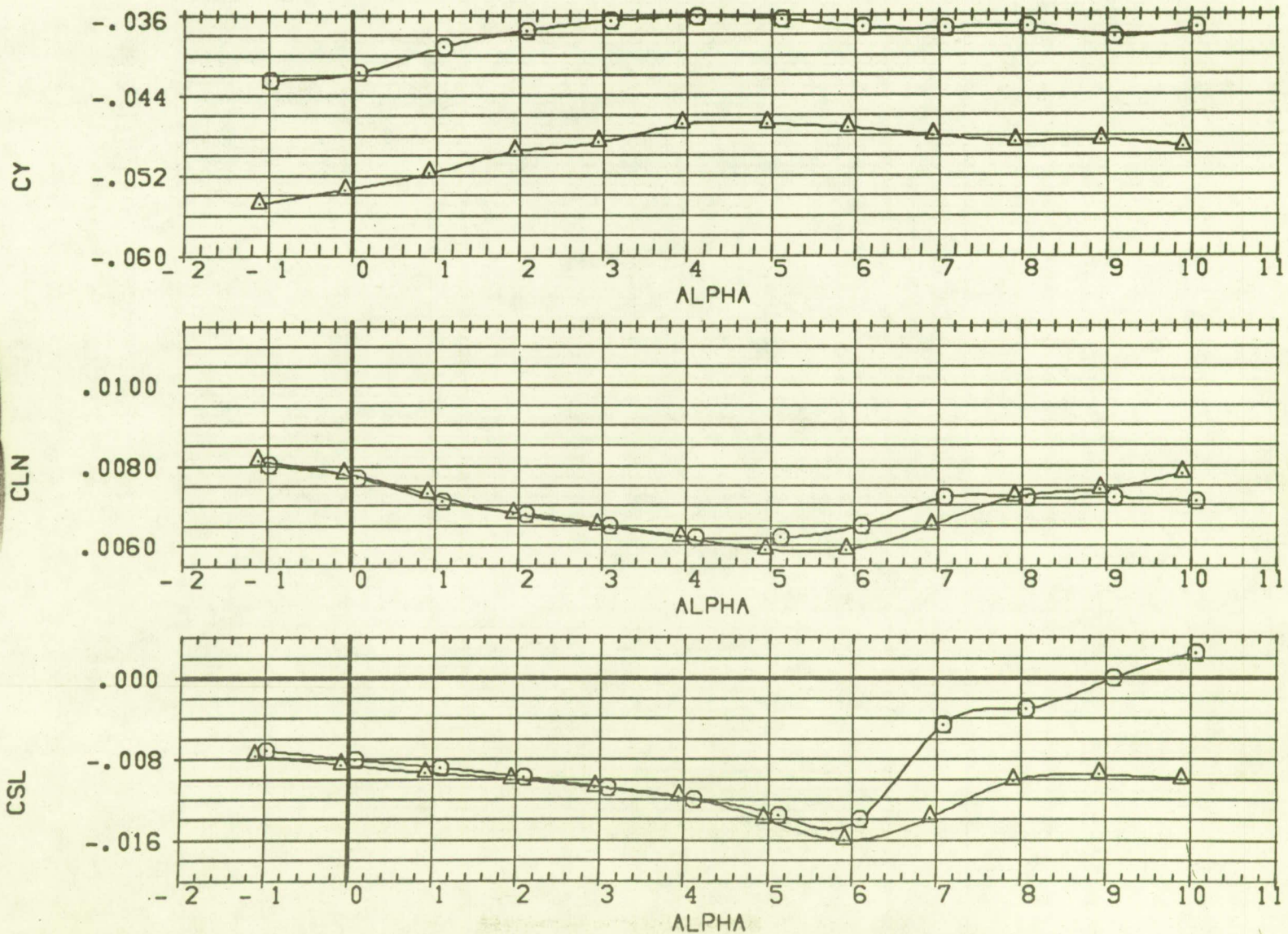

FIG 7 EFFECT OF ADDITION OF MAJOR COMPONENTS ON LAT-DIR AERODYN. IN PITCH

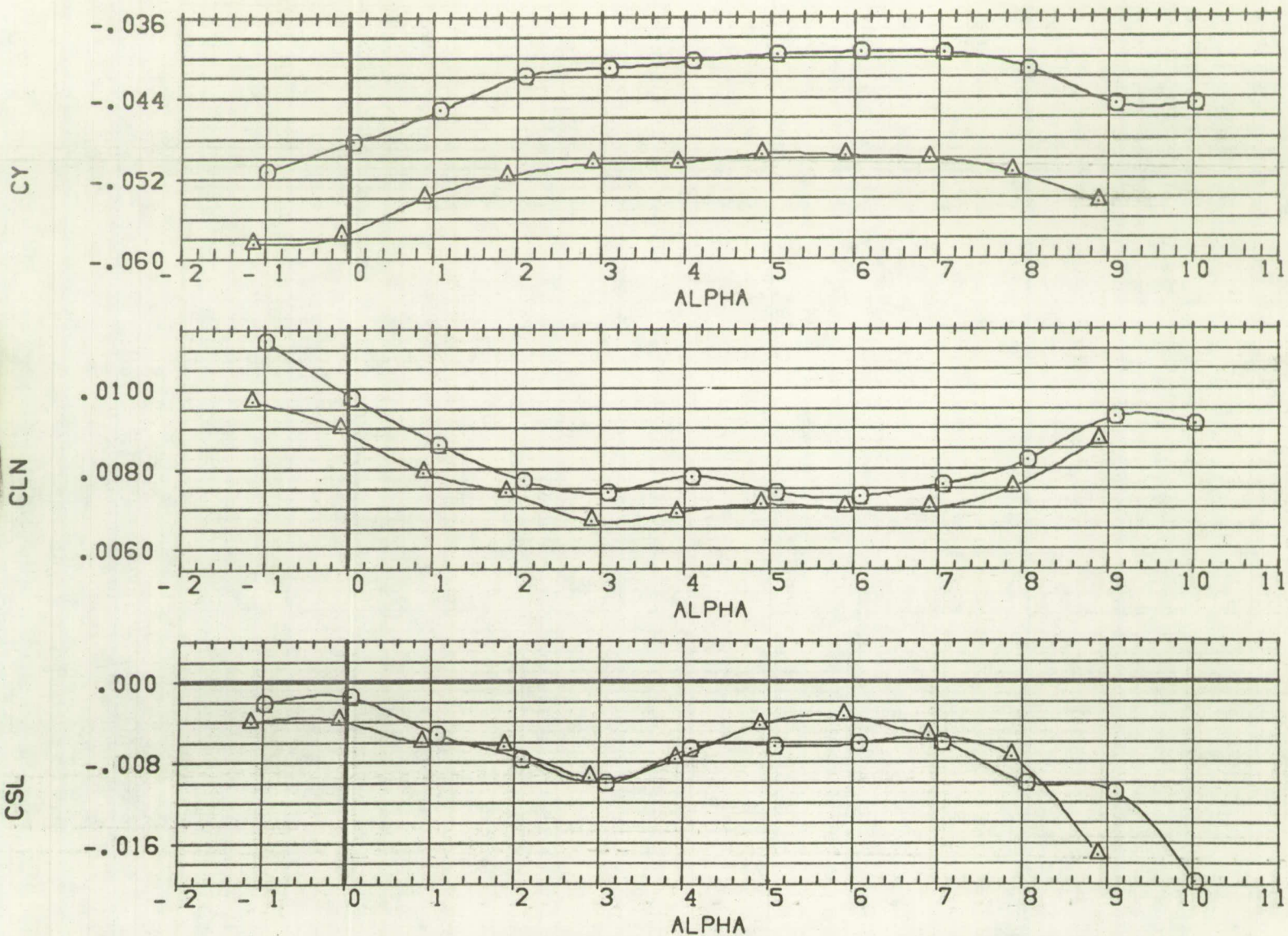



FIG 7 EFFECT OF ADDITION OF MAJOR COMPONENTS ON LAT-DIR AERODYN. IN PITCH
 (B)MACH = 0.95

DATA SET SYMBOL CONFIGURATION DESCRIPTION
 (FAF008)  W1 B1 V1 H1
 (FAF014)  W1 B1 V1 H1 K1 N1 K2 N2 ZF1

DBETA HORIZT SPLR-L TRANS
 3.000 -1.000 0.000 1.000
 3.000 -1.000 0.000 1.000

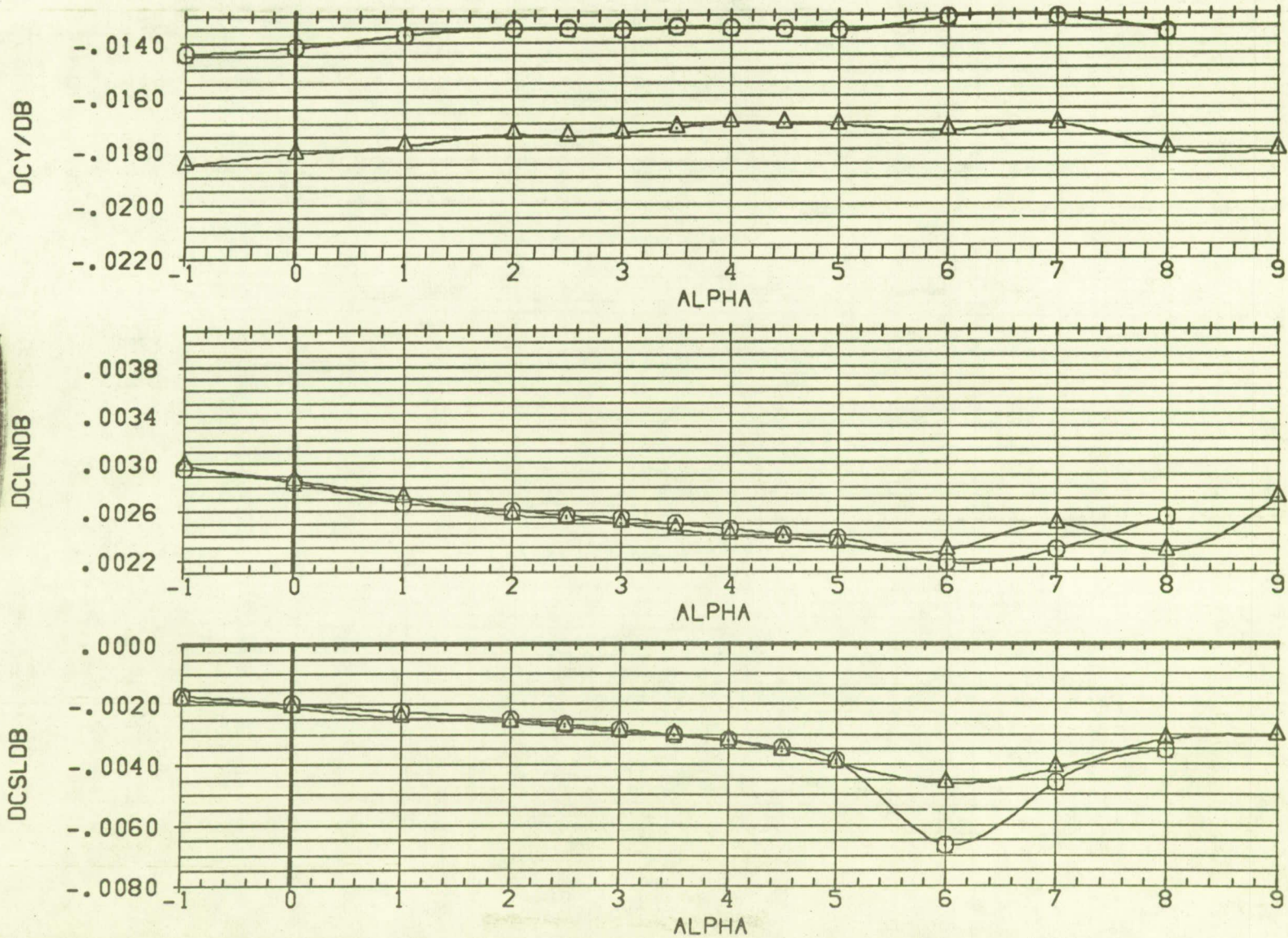

FIG 7 EFFECT OF ADDITION OF MAJOR COMPONENTS ON LAT-DIR AERODYN. IN PITCH

DATA SET SYMBOL CONFIGURATION DESCRIPTION
 (FAF008) \circ W1 B1 V1 H1
 (FAF014) \triangle W1 B1 V1 H1 K1 N1 K2 N2 ZF1

DBETA	HORIZT	SPLR-L	TRANS
3.000	-1.000	0.000	1.000
3.000	-1.000	0.000	1.000

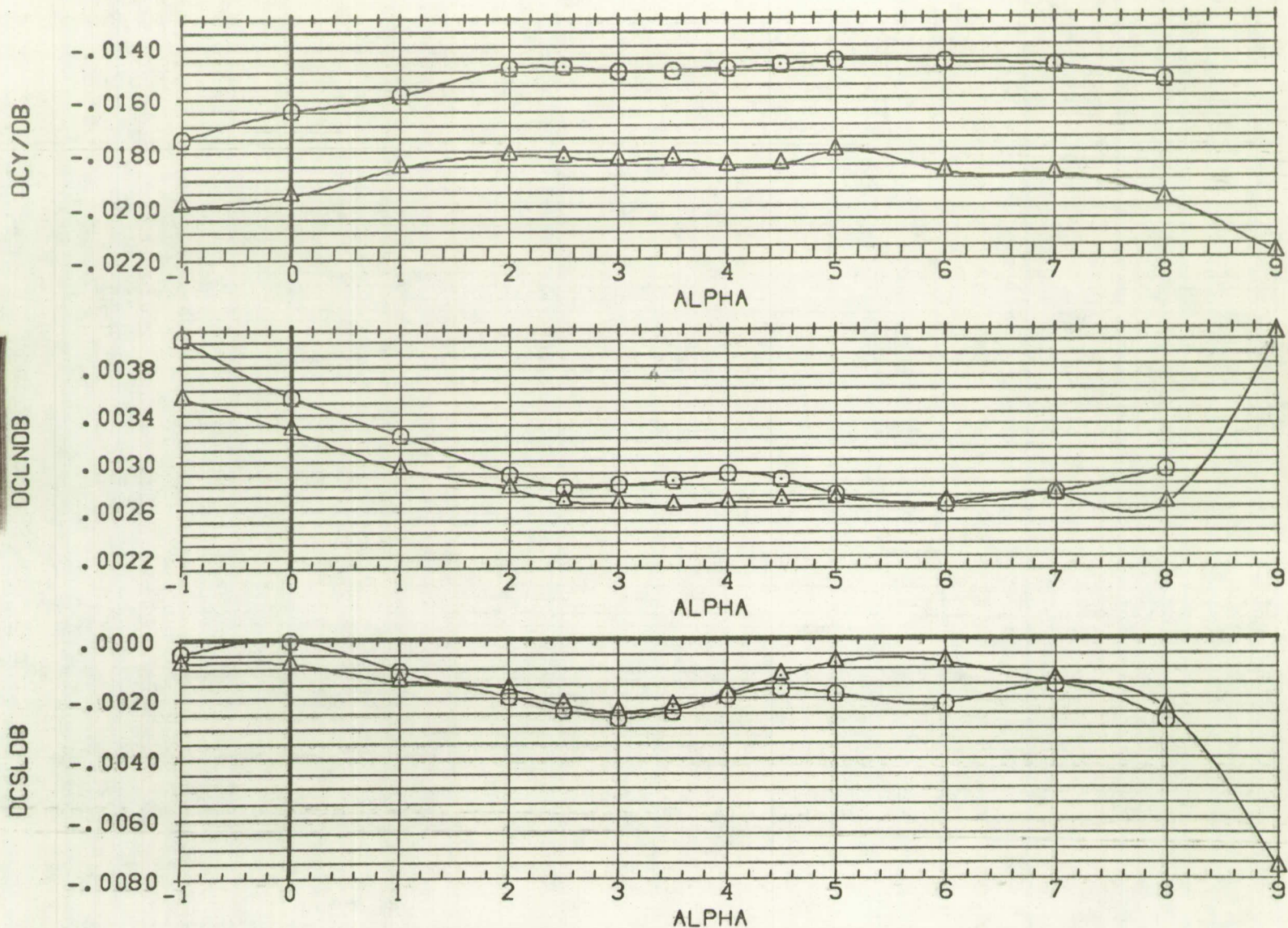

FIG 7 EFFECT OF ADDITION OF MAJOR COMPONENTS ON LAT-DIR AERODYN. IN PITCH
 (B)MACH = 0.95

DATA SET SYMBOL	CONFIGURATION DESCRIPTION
(HAFD13)	○ W1 B1 V1 H1 K1 N1 K2 N2 ZF1
(RAFD16)	△ W1 B1 V1 H1 K1 N1 K2 N2 ZF1
(RAFD17)	◇ W1 B1 V1 H1 K1 N1 K2 N2 ZF1

BETA	HORIZT	SPLR-L	TRANS
0.000	-1.000	0.000	1.000
0.000	-3.000	0.000	1.000
0.000	-5.000	0.000	1.000

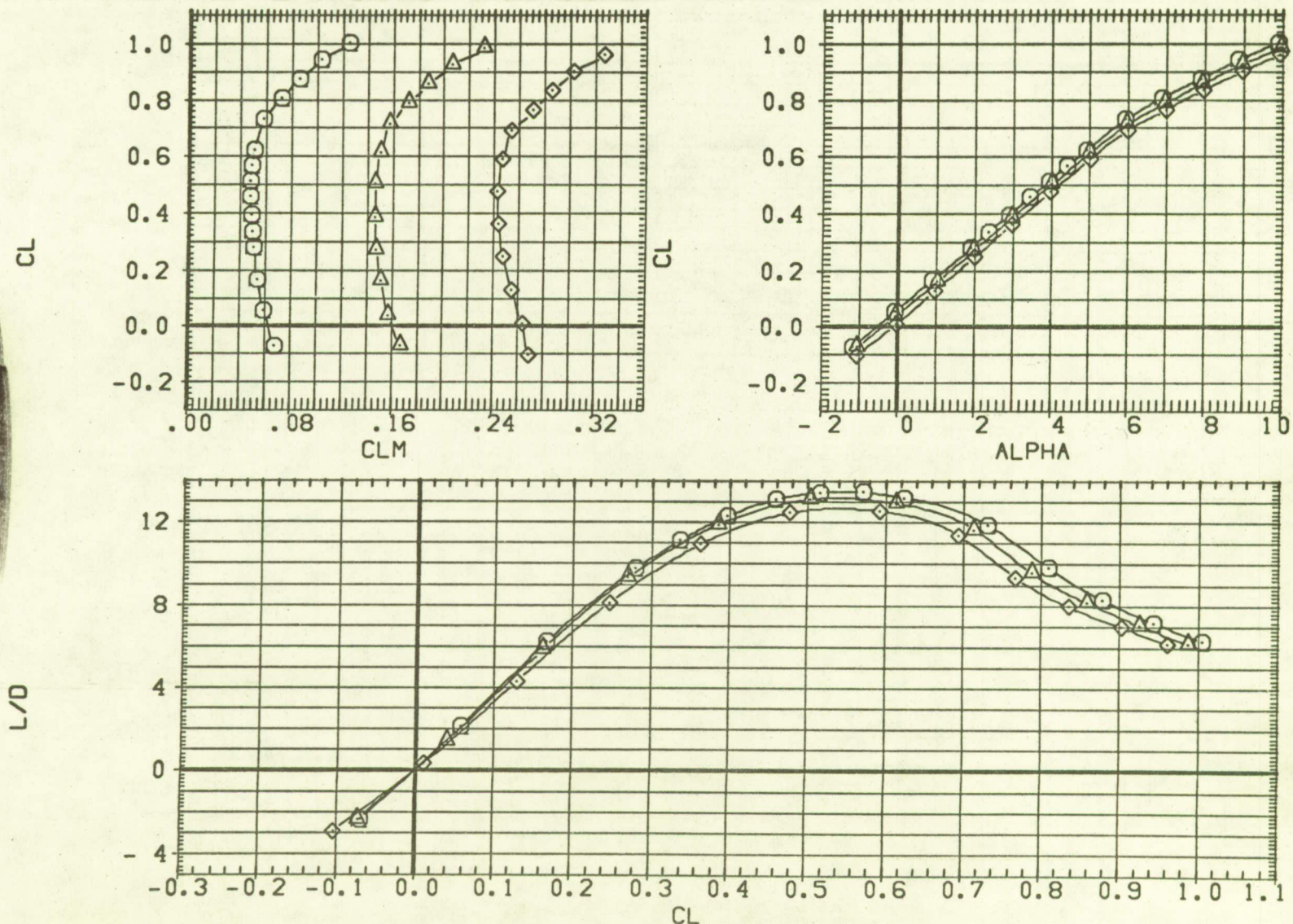

FIG 8 EFFECT OF HORIZONTAL TAIL DEFL. ON LONG. AERO. CHAR. OF FULL CONFIG.

(A) MACH = 0.80

DATA SET SYMBOL	CONFIGURATION DESCRIPTION
(HAFD13)	W1 B1 V1 H1 K1 N1 K2 N2 ZF1
(RAFD16)	W1 B1 V1 H1 K1 N1 K2 N2 ZF1
(RAFD17)	W1 B1 V1 H1 K1 N1 K2 N2 ZF1

BETA	HORIZT	SPLR-L	TRANS
0.000	-1.000	0.000	1.000
0.000	-3.000	0.000	1.000
0.000	-5.000	0.000	1.000

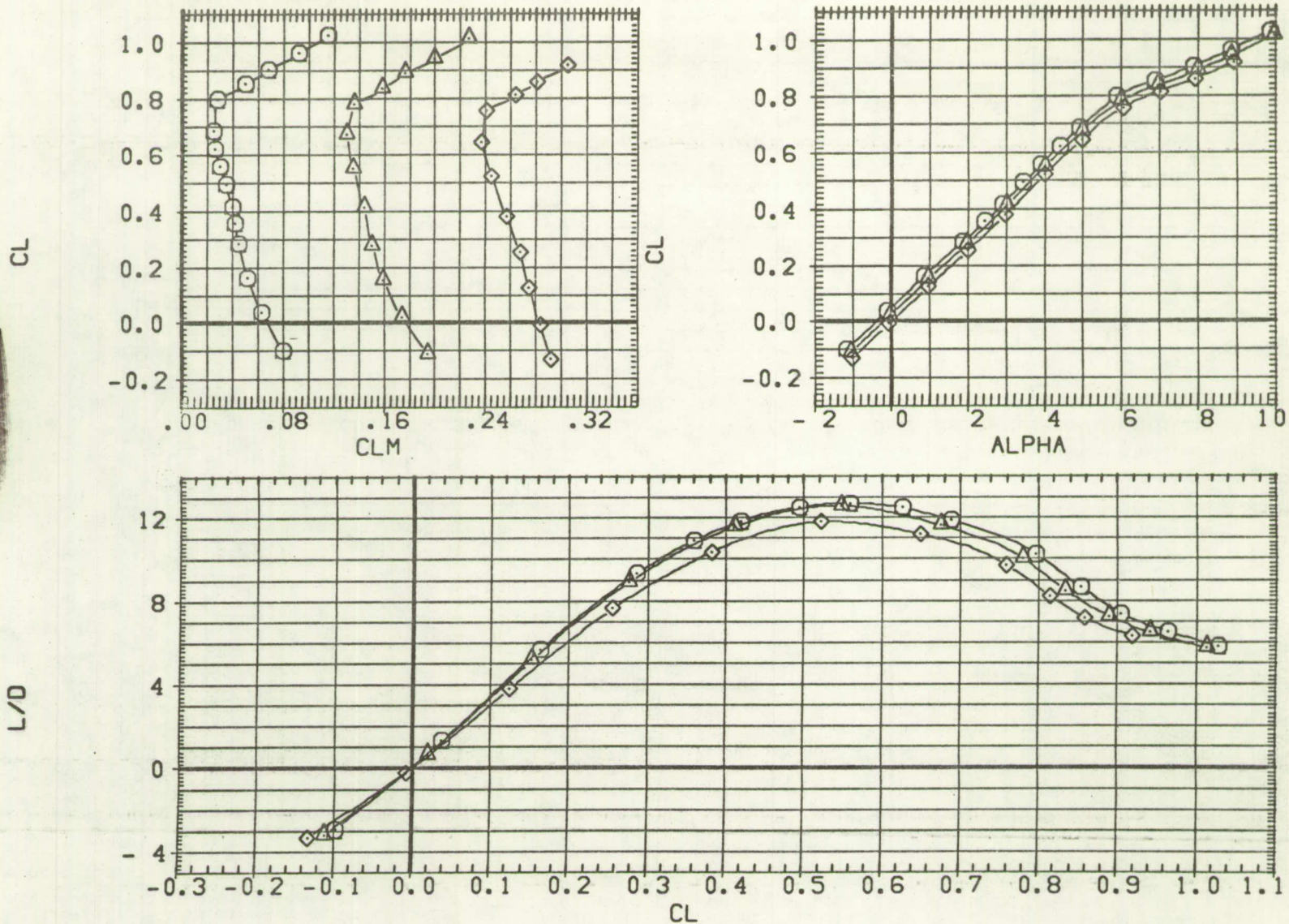

FIG 8 EFFECT OF HORIZONTAL TAIL DEFL. ON LONG. AERO. CHAR. OF FULL CONFIG.
 (B)MACH = 0.90

DATA SET SYMBOL	CONFIGURATION DESCRIPTION
(HAF013)	W1 B1 V1 H1 K1 N1 K2 N2 ZF1
(RAFD16)	W1 B1 V1 H1 K1 N1 K2 N2 ZF1
(RAFD17)	W1 B1 V1 H1 K1 N1 K2 N2 ZF1

BETA	HORIZT	SPLR-L	TRANS
0.000	-1.000	0.000	1.000
0.000	-3.000	0.000	1.000
0.000	-5.000	0.000	1.000

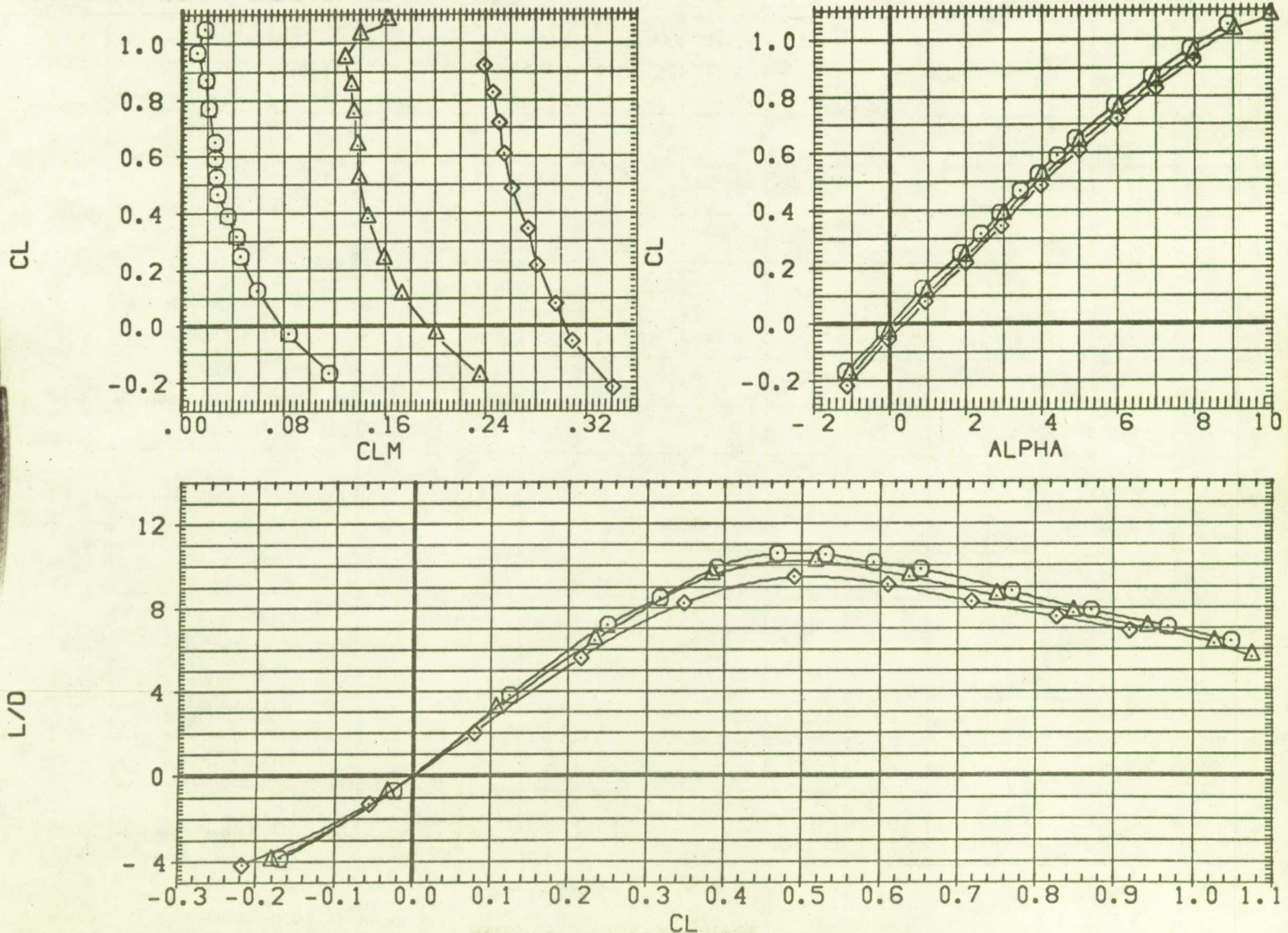

FIG 8 EFFECT OF HORIZONTAL TAIL DEFL. ON LONG. AERO. CHAR. OF FULL CONFIG.

DATA SET SYMBOL	CONFIGURATION DESCRIPTION
(RAFD13)	W1 B1 V1 H1 K1 N1 K2 N2 ZF1
(RAFD16)	W1 B1 V1 H1 K1 N1 K2 N2 ZF1
(RAFD17)	W1 B1 V1 H1 K1 N1 K2 N2 ZF1

BETA	HORIZT	SPLR-L	TRANS
0.000	-1.000	0.000	1.000
0.000	-3.000	0.000	1.000
0.000	-5.000	0.000	1.000

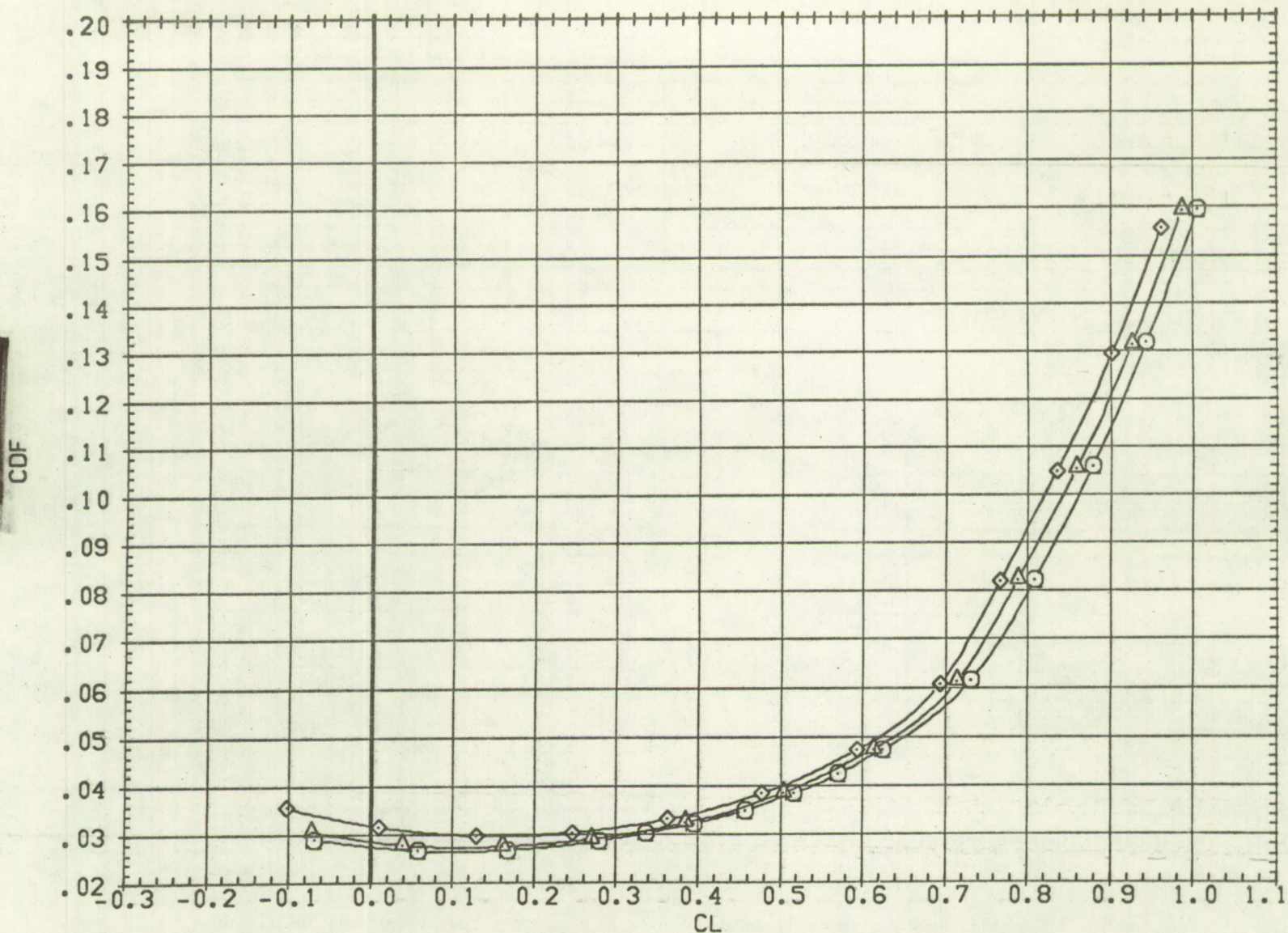

FIG 8 EFFECT OF HORIZONTAL TAIL DEFL. ON LONG. AERO. CHAR. OF FULL CONFIG.
 (A)MACH = 0.80

DATA SET SYMBOL	CONFIGURATION DESCRIPTION
(HAF013)	W1 B1 V1 H1 K1 N1 K2 N2 ZF1
(RAFO16)	W1 B1 V1 H1 K1 N1 K2 N2 ZF1
(RAFO17)	W1 B1 V1 H1 K1 N1 K2 N2 ZF1

BETA	HORIZT	SPLR-L	TRANS
0.000	-1.000	0.000	1.000
0.000	-3.000	0.000	1.000
0.000	-5.000	0.000	1.000

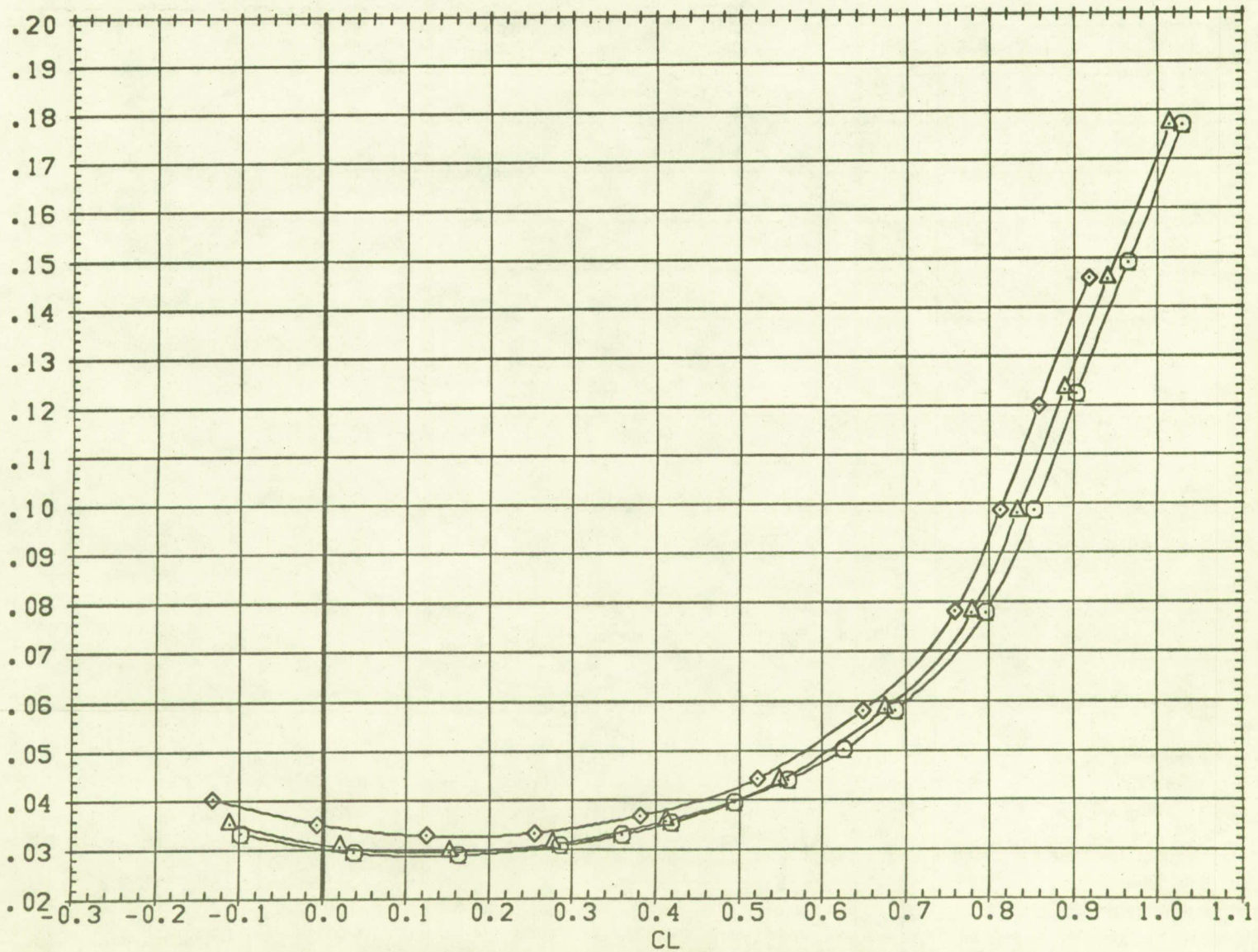

FIG 8 EFFECT OF HORIZONTAL TAIL DEFL. ON LONG. AERO. CHAR. OF FULL CONFIG.

(B)MACH = 0.90

DATA SET SYMBOL	CONFIGURATION DESCRIPTION
(HAFD13)	○ W1 B1 V1 H1 K1 N1 K2 N2 ZF1
(RAFD16)	△ W1 B1 V1 H1 K1 N1 K2 N2 ZF1
(RAFD17)	◇ W1 B1 V1 H1 K1 N1 K2 N2 ZF1

BETA	HORIZT	SPLR-L	TRANS
0.000	-1.000	0.000	1.000
0.000	-3.000	0.000	1.000
0.000	-5.000	0.000	1.000

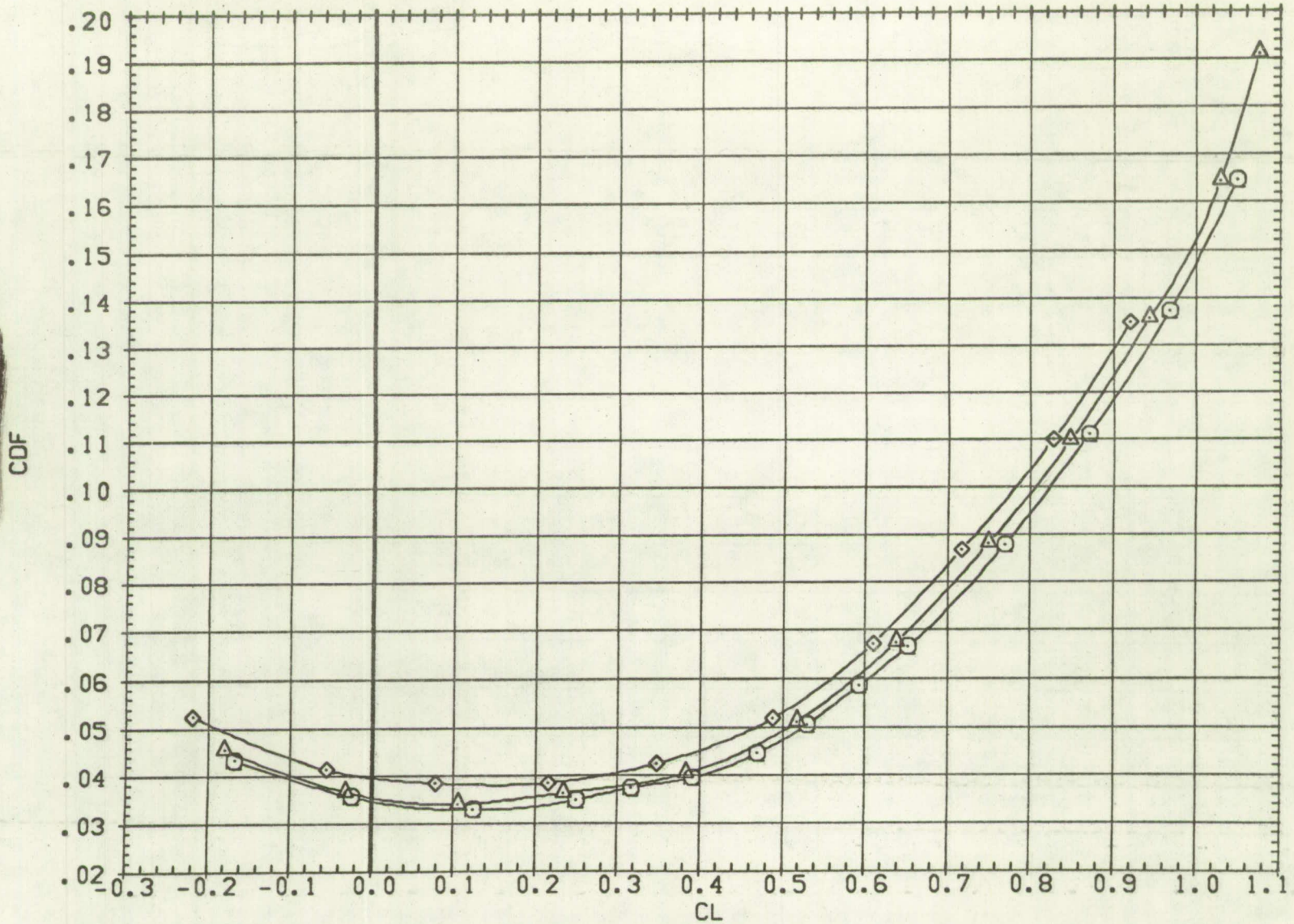

FIG 8 EFFECT OF HORIZONTAL TAIL DEFL. ON LONG. AERO. CHAR. OF FULL CONFIG.
 (C)MACH = 0.95

DATA SET SYMBOL CONFIGURATION DESCRIPTION
 (HAF007) ○ W1 B1 V1 H1
 (RAF006) △ W1 B1 V1 H1

BETA HORIZT SPLR-L TRANS
 0.000 -1.000 0.000 1.000
 0.000 -3.000 0.000 1.000

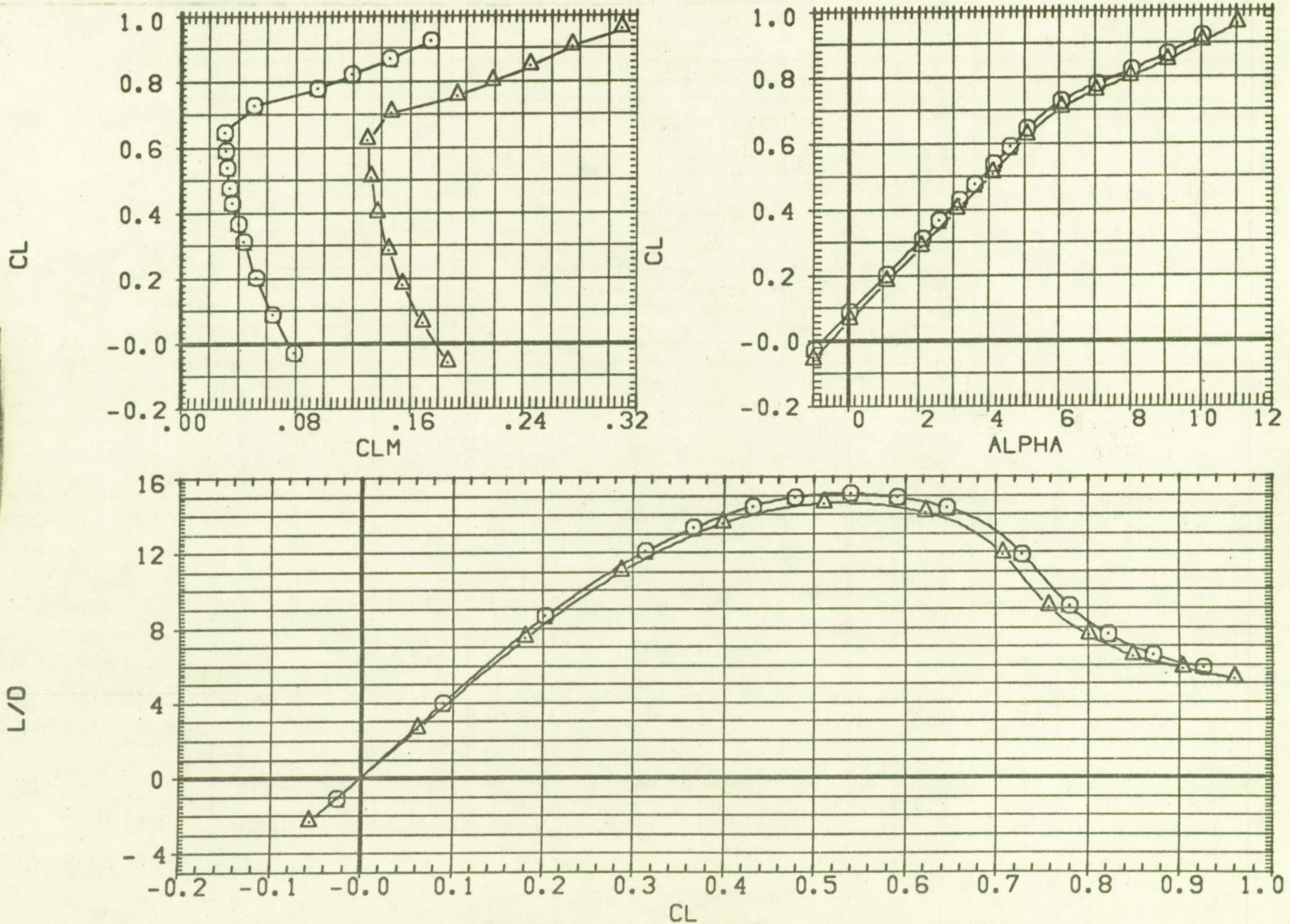

FIG 9 EFFECT OF HORIZONTAL TAIL DEFL. ON LONG. AERO. CHAR. OF WING-BODY-TAIL

(A)MACH = 0.80

DATA SET SYMBOL CONFIGURATION DESCRIPTION
 (HAF007) ○ W1 B1 V1 H1
 (RAF006) △ W1 B1 V1 H1

BETA HORIZT SPLR-L TRANS
 0.000 -1.000 0.000 1.000
 0.000 -3.000 0.000 1.000

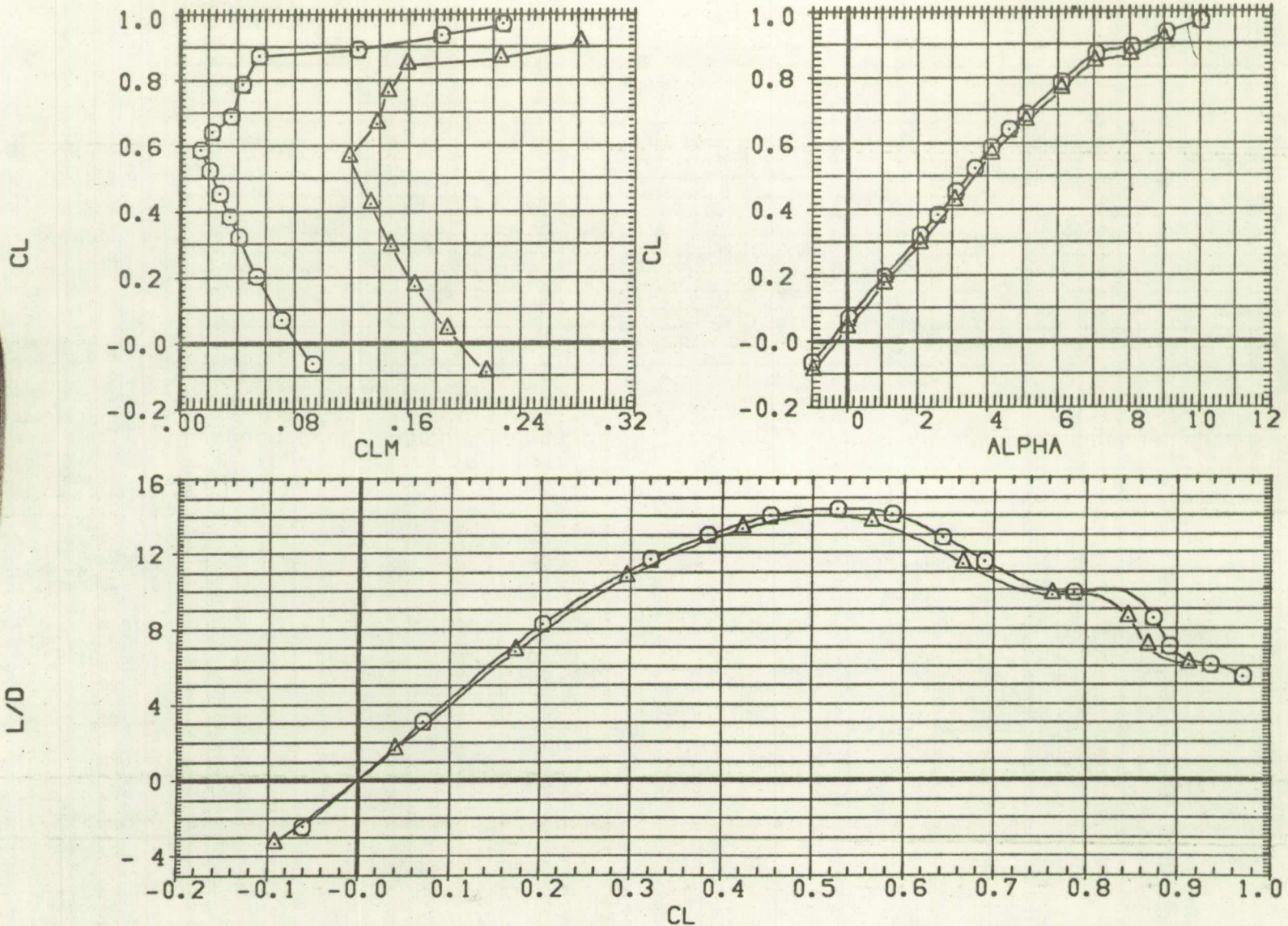

FIG 9 EFFECT OF HORIZONTAL TAIL DEFL. ON LONG. AERO. CHAR. OF WING-BODY-TAIL
 (B)MACH = 0.90

DATA SET SYMBOL CONFIGURATION DESCRIPTION
 (HAF007) (HAF006) \circ Δ W1 B1 V1 H1
 W1 B1 V1 H1

BETA	HORIZT	SPLR-L	TRANS
0.000	-1.000	0.000	1.000
0.000	-3.000	0.000	1.000

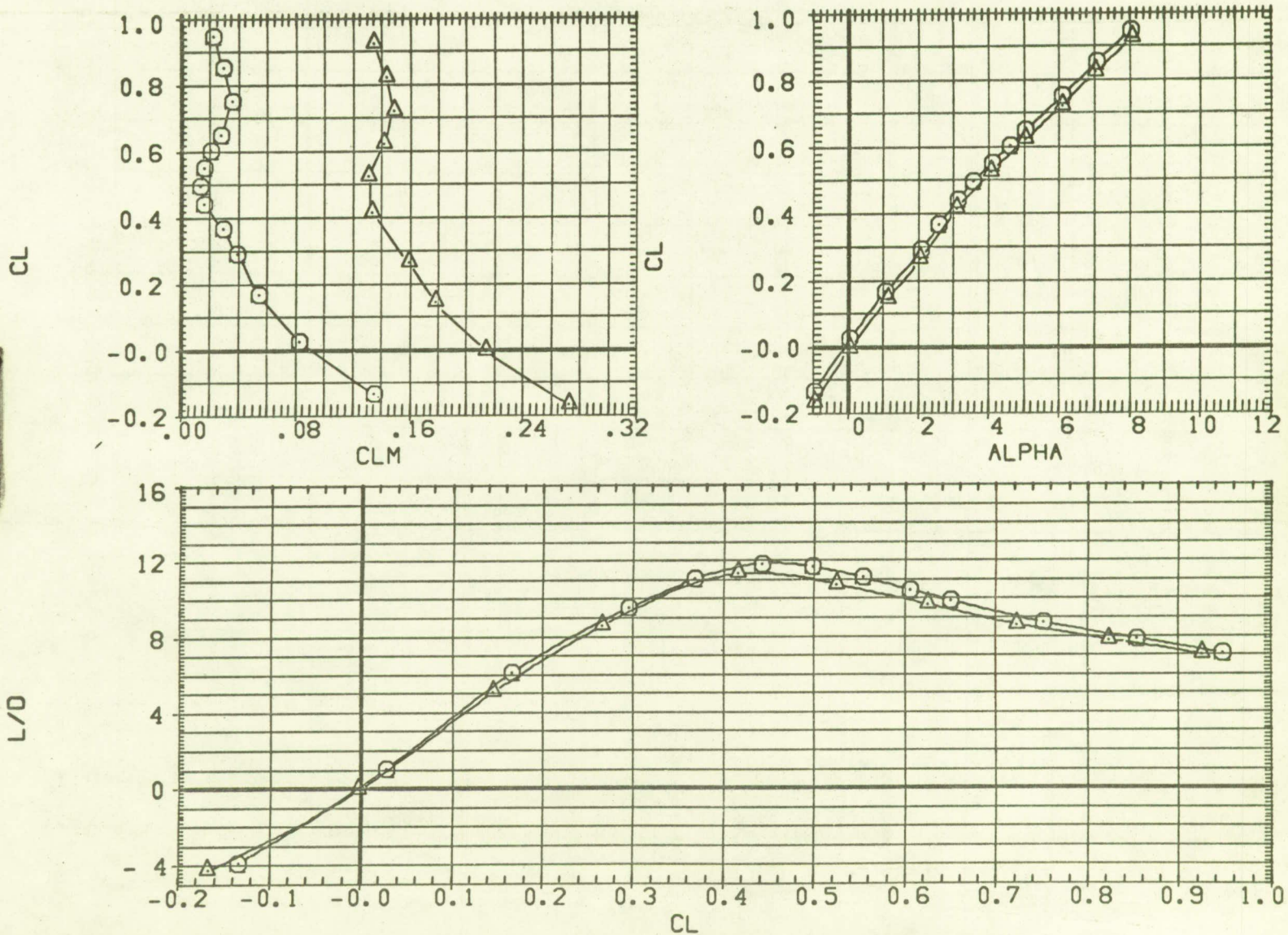

FIG 9 EFFECT OF HORIZONTAL TAIL DEFL. ON LONG. AERO. CHAR. OF WING-BODY-TAIL
 (C)MACH = 0.95

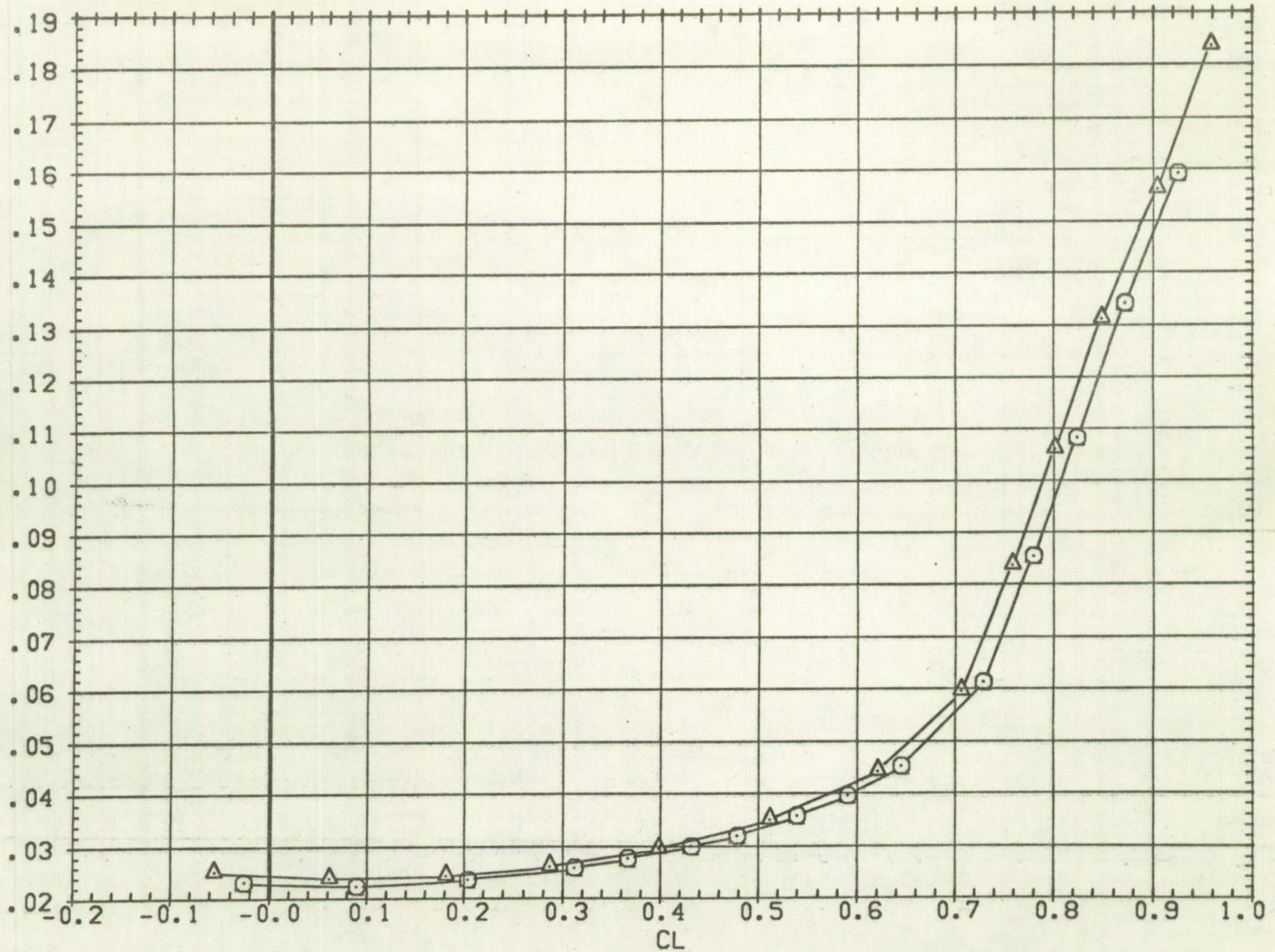

FIG 9 EFFECT OF HORIZONTAL TAIL DEFL. ON LONG. AERO. CHAR. OF WING-BODY-TAIL
 (A)MACH = 0.80

DATA SET SYMBOL CONFIGURATION DESCRIPTION
 (HAF007) ○ W1 B1 V1 H1
 (RAF006) △ W1 B1 V1 H1

BETA	HORIZT	SPLR-L	TRANS
0.000	-1.000	0.000	1.000
0.000	-3.000	0.000	1.000

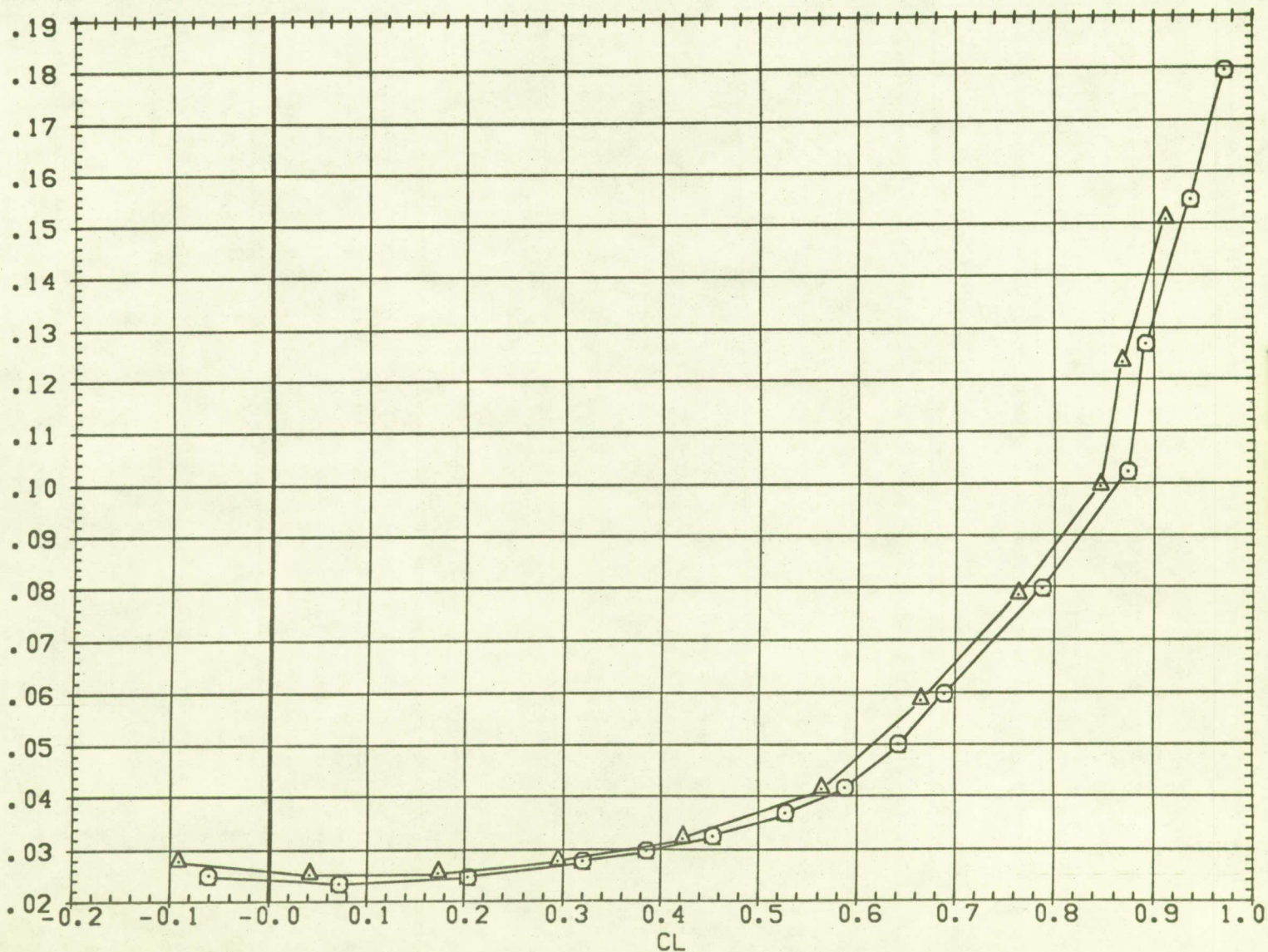

FIG 9 EFFECT OF HORIZONTAL TAIL DEFL. ON LONG. AERO. CHAR. OF WING-BODY-TAIL

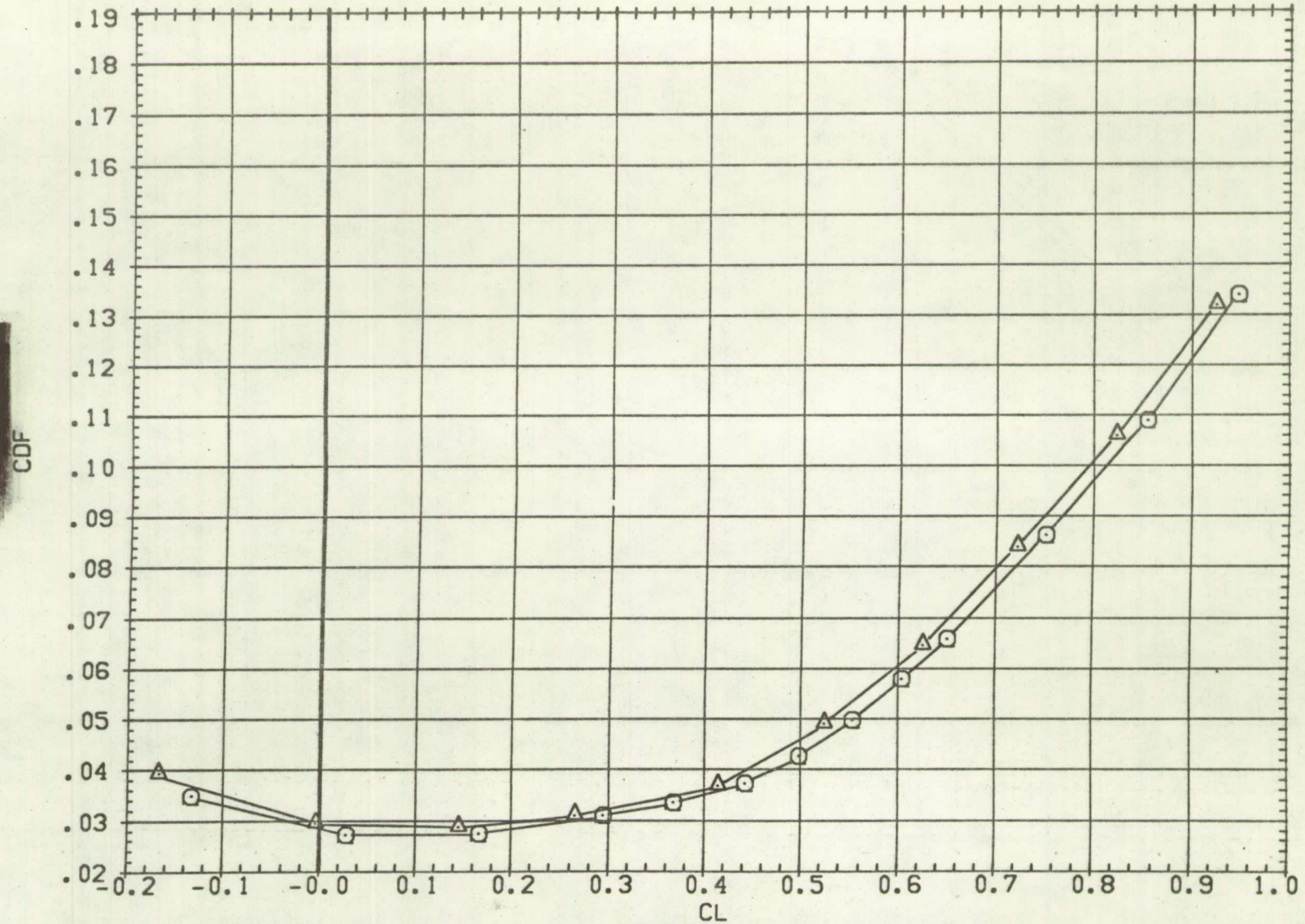

FIG 9 EFFECT OF HORIZONTAL TAIL DEFL. ON LONG. AERO. CHAR. OF WING-BODY-TAIL
 (C)MACH = 0.95

DATA SET SYMBOL	CONFIGURATION DESCRIPTION
(HAFO13)	W1 B1 V1 H1 K1 N1 K2 N2 ZF1
(RAFO18)	W1 B1 V1 H1 K1 N1 K2 N2 ZF1 S1
(RAFO19)	W1 B1 V1 H1 K1 N1 K2 N2 ZF1 S1

BETA	HORIZT	SPLR-L	TRANS
0.000	-1.000	0.000	1.000
0.000	-1.000	-10.000	1.000
0.000	-1.000	-25.000	1.000

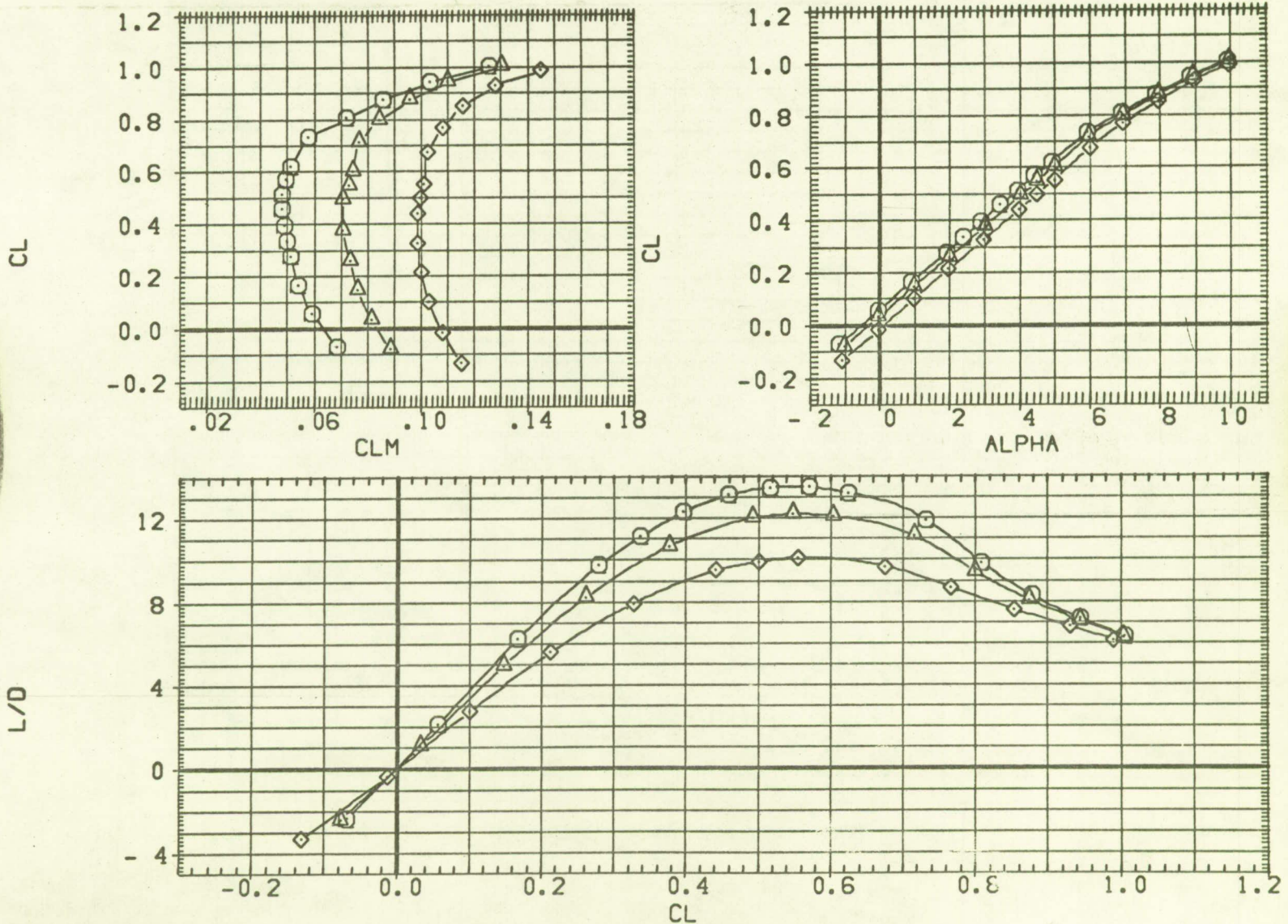

FIG 10 EFFECT OF SPOILER ON LONGITUDINAL AERODYNAMICS

(A)MACH = 0.80

DATA SET SYMBOL	CONFIGURATION DESCRIPTION
(HAFD13)	W1 B1 V1 H1 K1 N1 K2 N2 ZF1
(RAFD18)	W1 B1 V1 H1 K1 N1 K2 N2 ZF1 S1
(RAFD19)	W1 B1 V1 H1 K1 N1 K2 N2 ZF1 S1

BETA	HORIZT	SPLR-L	TRANS
0.000	-1.000	0.000	1.000
0.000	-1.000	-10.000	1.000
0.000	-1.000	-25.000	1.000

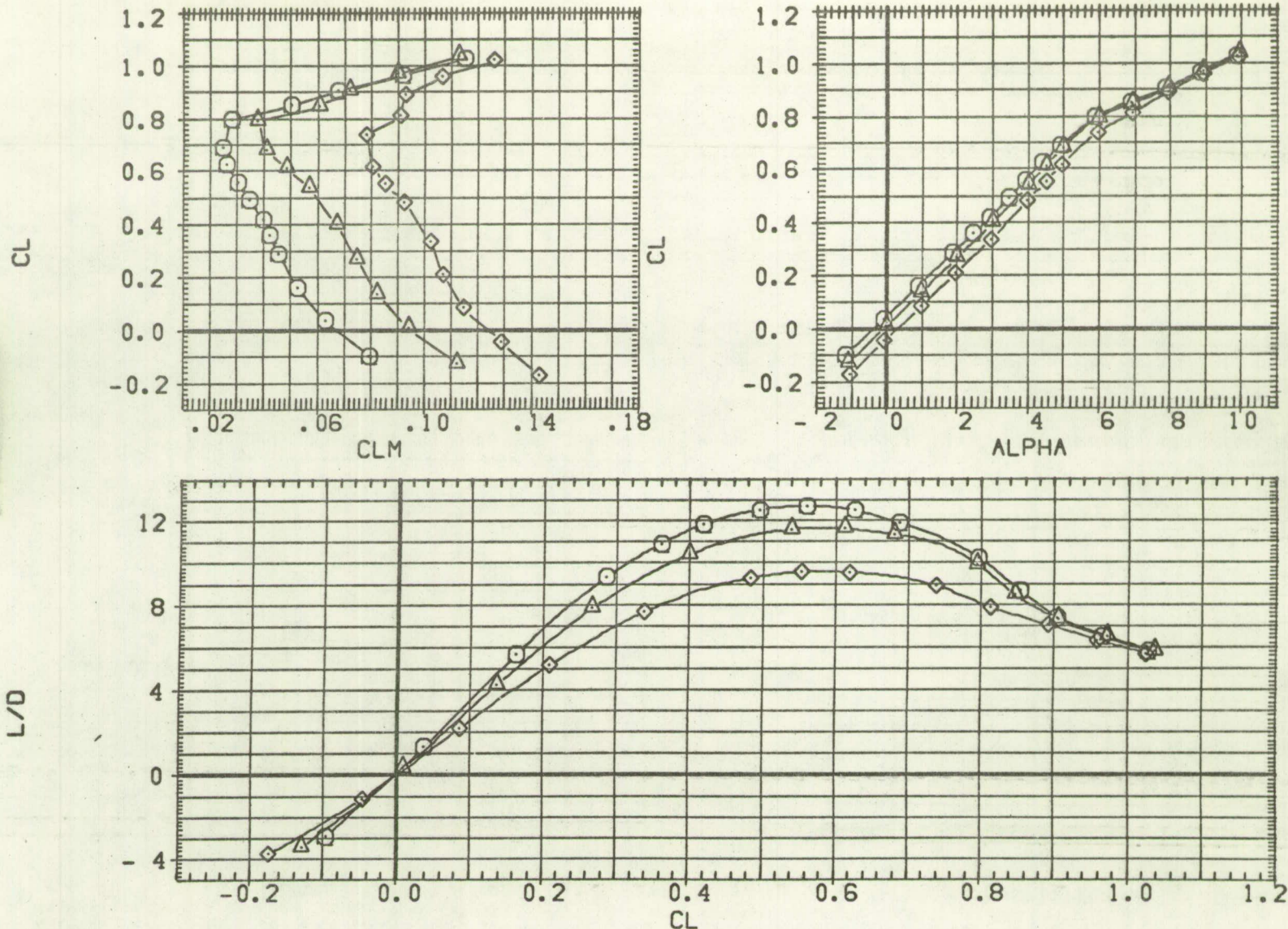

FIG 10 EFFECT OF SPOILER ON LONGITUDINAL AERODYNAMICS
 (B)MACH = 0.90

DATA SET SYMBOL	CONFIGURATION DESCRIPTION
(HAFD13)	W1 B1 V1 H1 K1 N1 K2 N2 ZF1
(RAFD18)	W1 B1 V1 H1 K1 N1 K2 N2 ZF1 S1
(RAFD19)	W1 B1 V1 H1 K1 N1 K2 N2 ZF1 S1

BETA	HORIZT	SPLR-L	TRANS
0.000	-1.000	0.000	1.000
0.000	-1.000	-10.000	1.000
0.000	-1.000	-25.000	1.000

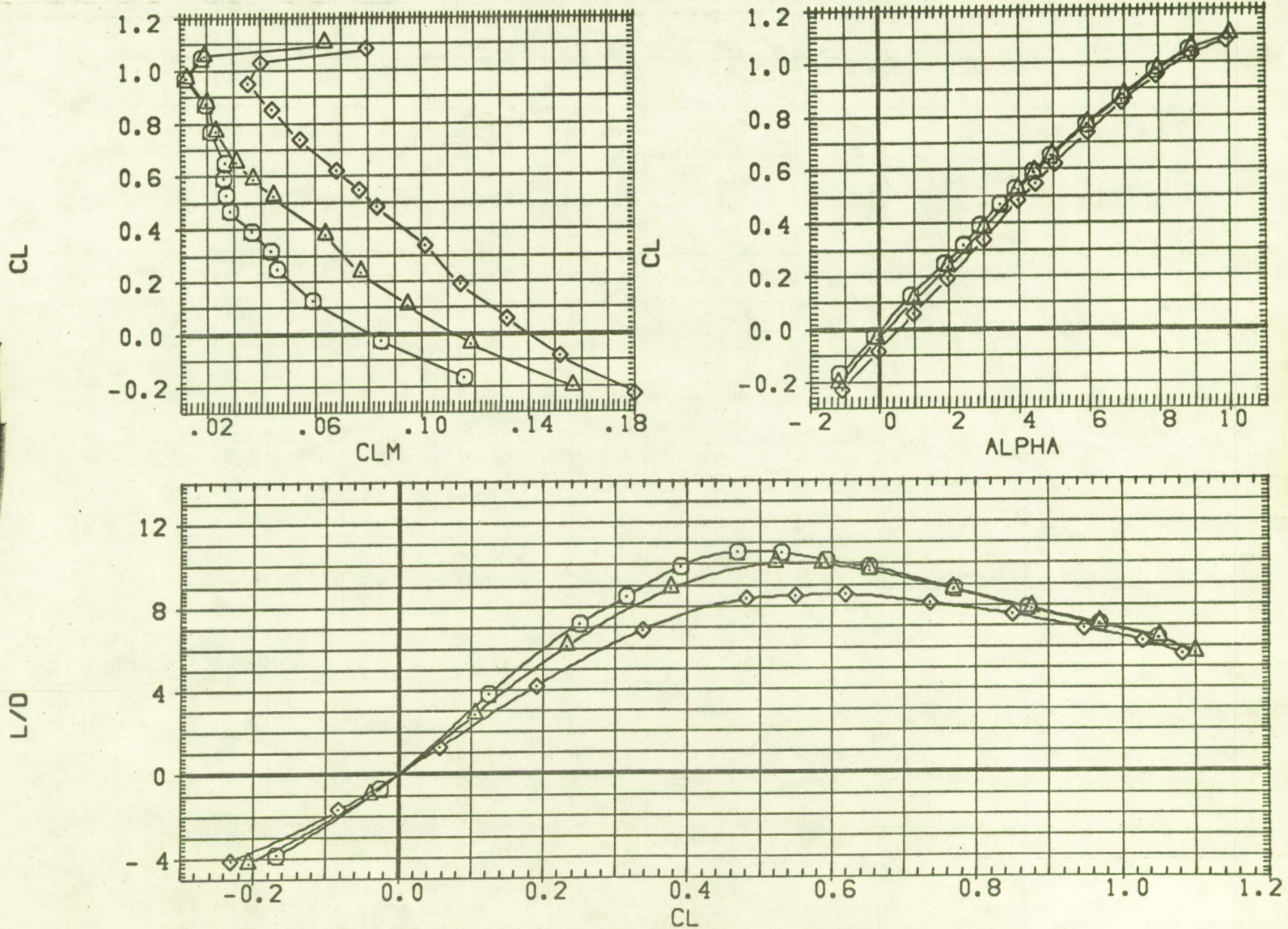

FIG 10 EFFECT OF SPOILER ON LONGITUDINAL AERODYNAMICS

(C)MACH = 0.95

DATA SET SYMBOL	CONFIGURATION DESCRIPTION
(HAF013)	W1 B1 V1 H1 K1 N1 K2 N2 ZF1
(RAF016)	W1 B1 V1 H1 K1 N1 K2 N2 ZF1 S1
(RAF019)	W1 B1 V1 H1 K1 N1 K2 N2 ZF1 S1

BETA	HORIZT	SPLR-L	TRANS
0.000	-1.000	0.000	1.000
0.000	-1.000	-10.000	1.000
0.000	-1.000	-25.000	1.000

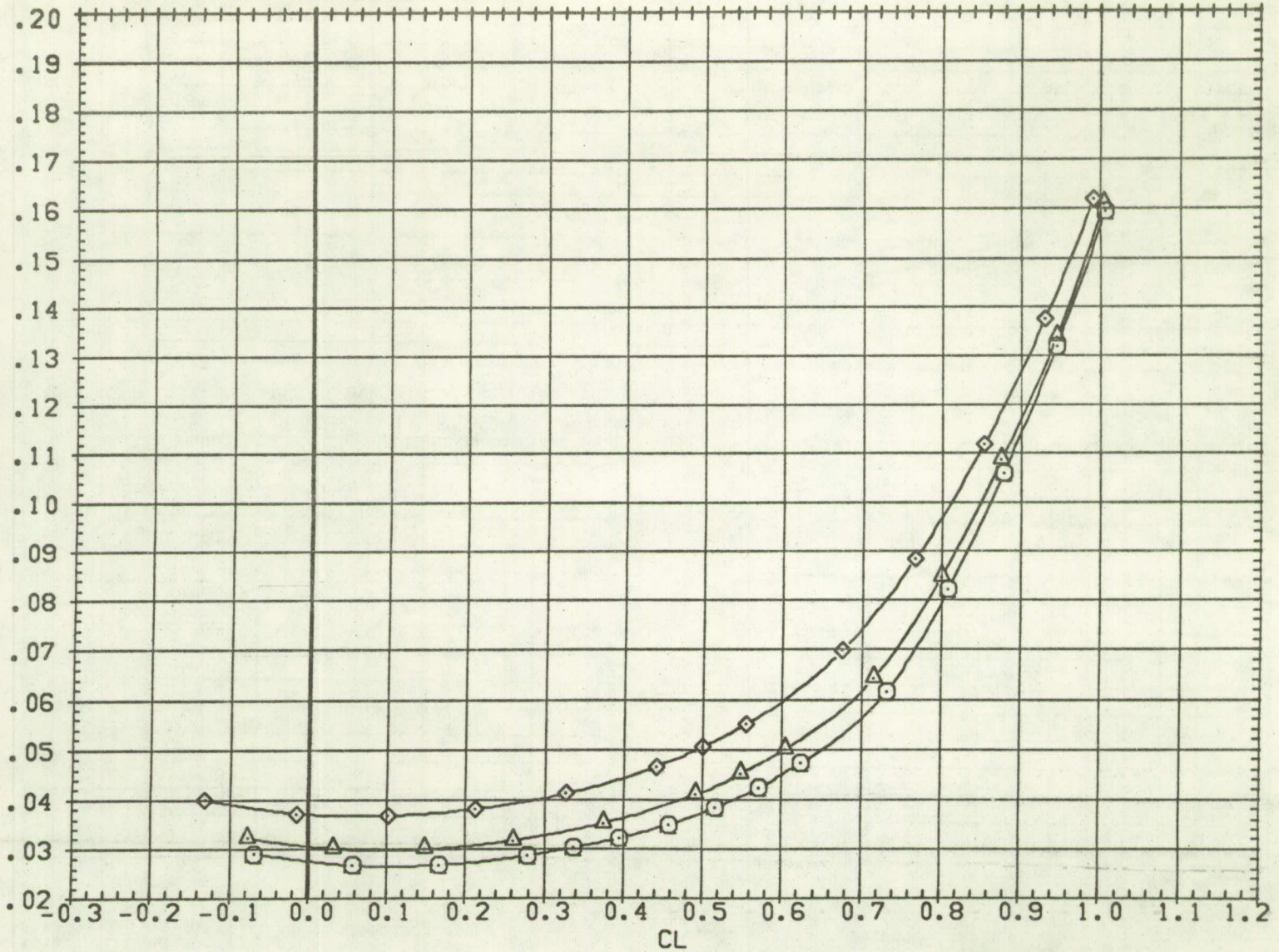

FIG 10 EFFECT OF SPOILER ON LONGITUDINAL AERODYNAMICS
 (A)MACH = 0.80

DATA SET SYMBOL	CONFIGURATION DESCRIPTION
(HAF013)	W1 B1 V1 H1 K1 N1 K2 N2 ZF1
(RAF018)	W1 B1 V1 H1 K1 N1 K2 N2 ZF1 S1
(RAF019)	W1 B1 V1 H1 K1 N1 K2 N2 ZF1 S1

BETA	HORIZT	SPLR-L	TRANS
0.000	-1.000	0.000	1.000
0.000	-1.000	-10.000	1.000
0.000	-1.000	-25.000	1.000

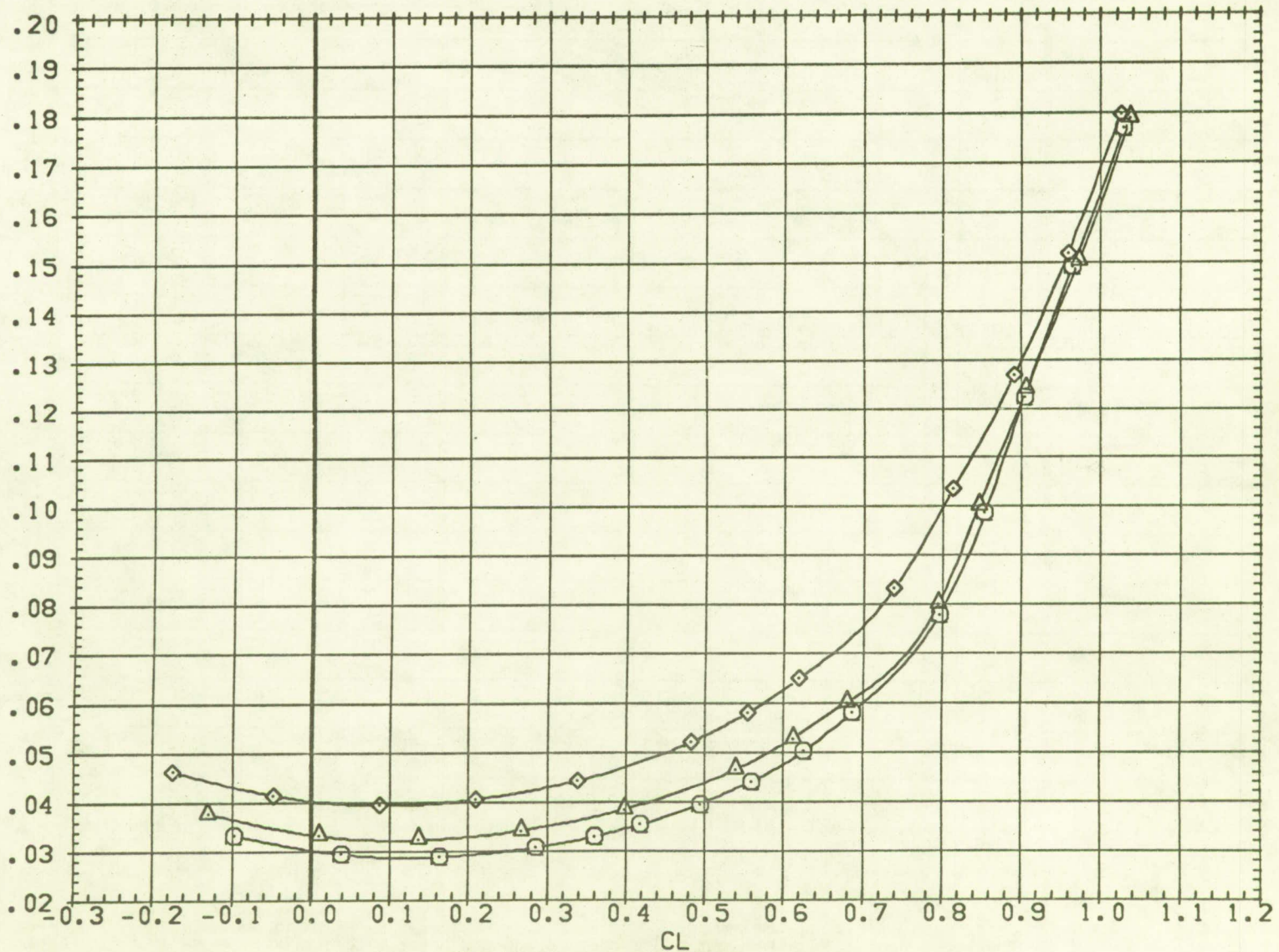

FIG 10 EFFECT OF SPOILER ON LONGITUDINAL AERODYNAMICS

DATA SET SYMBOL	CONFIGURATION DESCRIPTION
(HAF013)	W1 B1 V1 H1 K1 N1 K2 N2 ZF1
(RAFD18)	W1 B1 V1 H1 K1 N1 K2 N2 ZF1 S1
(RAFD19)	W1 B1 V1 H1 K1 N1 K2 N2 ZF1 S1

BETA	HORIZT	SPLR-L	TRANS
0.000	-1.000	0.000	1.000
0.000	-1.000	-10.000	1.000
0.000	-1.000	-25.000	1.000

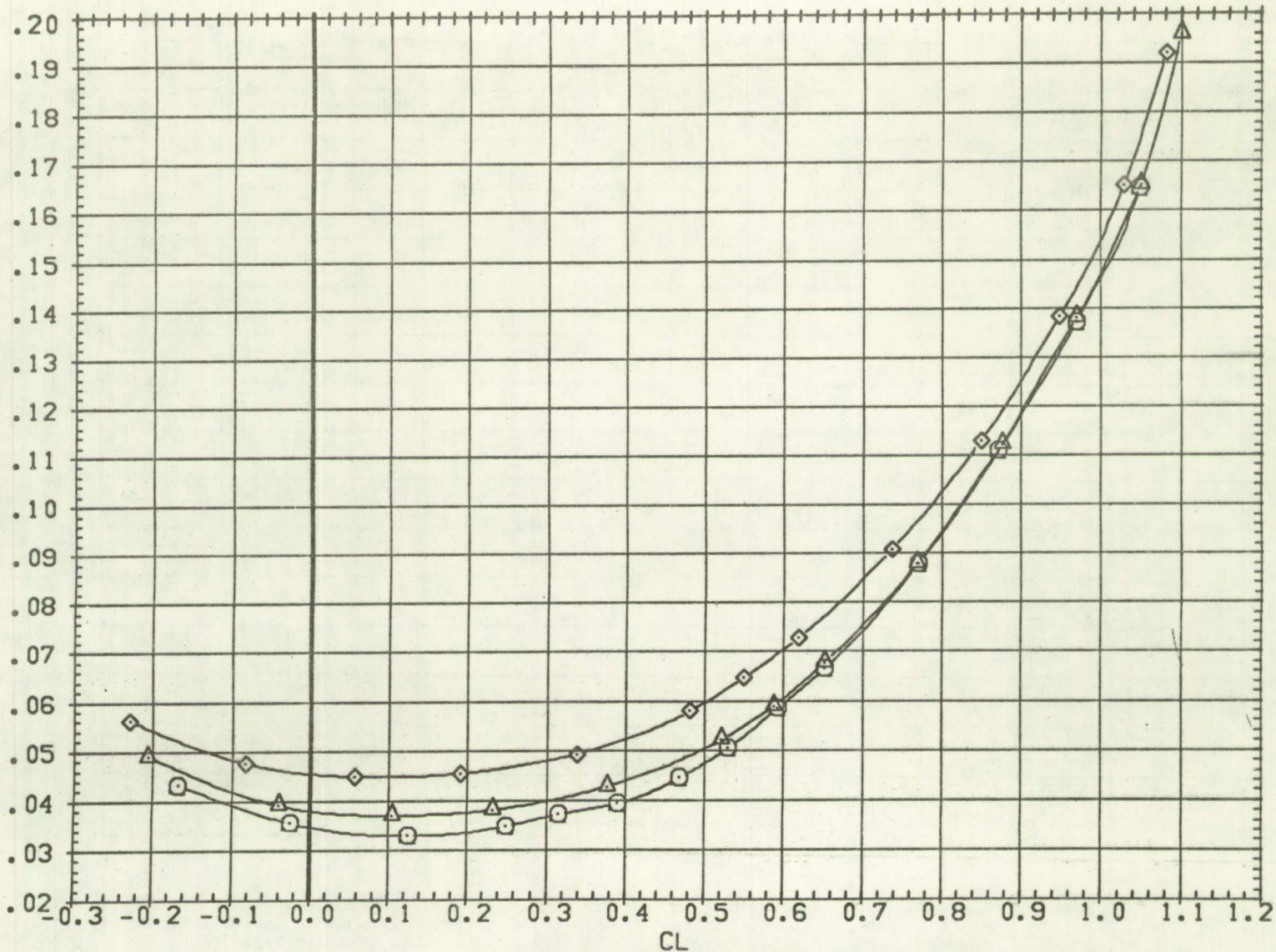

FIG 10 EFFECT OF SPOILER ON LONGITUDINAL AERODYNAMICS
 (C)MACH = 0.95

DATA SET SYMBOL	CONFIGURATION DESCRIPTION
(HAF013)	W1 B1 V1 H1 K1 N1 K2 N2 ZF1
(RAF018)	W1 B1 V1 H1 K1 N1 K2 N2 ZF1 S1
(RAF019)	W1 B1 V1 H1 K1 N1 K2 N2 ZF1 S1

BETA	HORIZT	SPLR-L	TRANS
0.000	-1.000	0.000	1.000
0.000	-1.000	-10.000	1.000
0.000	-1.000	-25.000	1.000

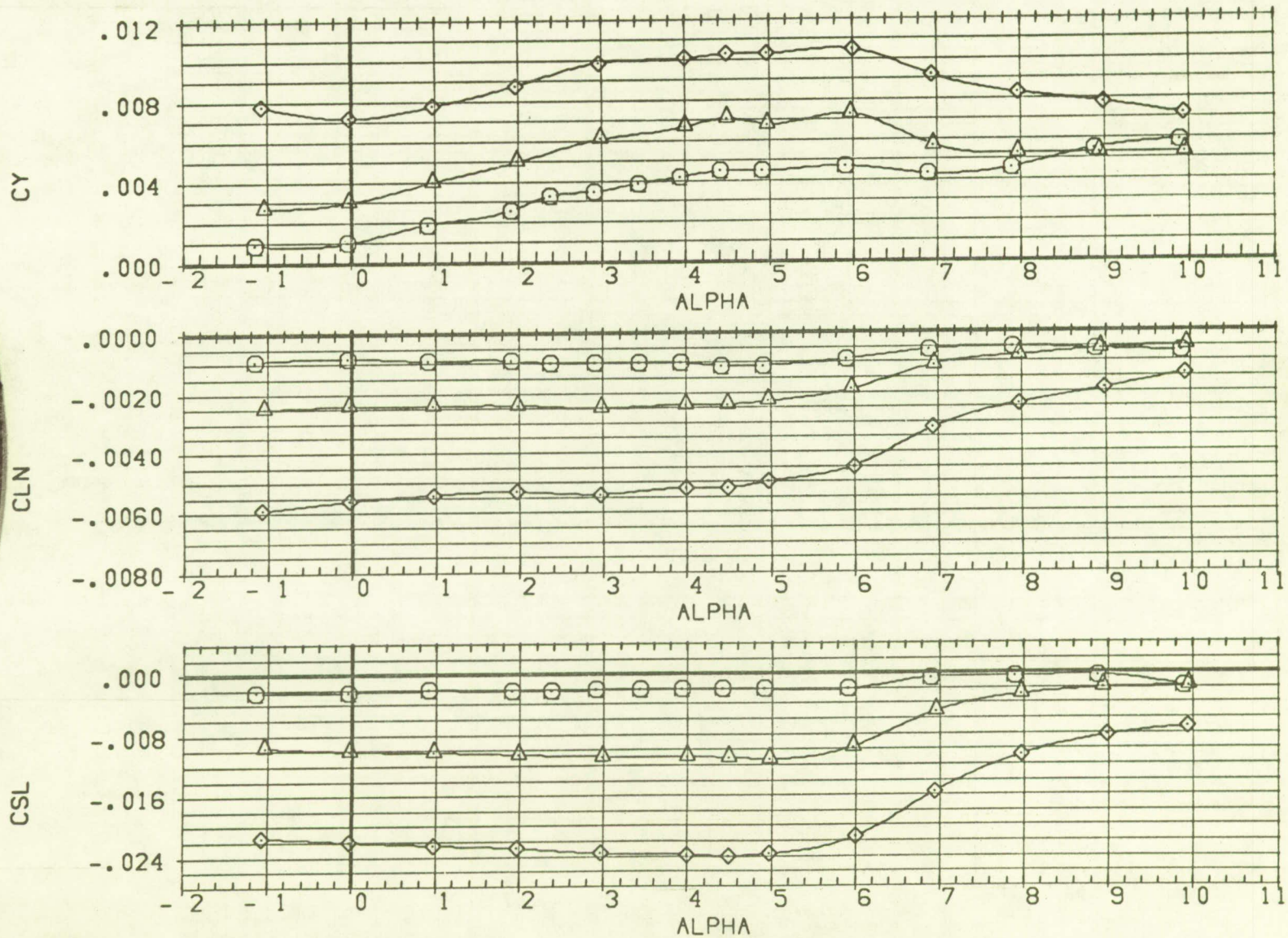

FIG 11 EFFECT OF SPOILER ON LAT-DIR AERODYNAMICS AT BETA= 0

(A)MACH = 0.80

DATA SET SYMBOL	CONFIGURATION DESCRIPTION
(HAF013)	W1 B1 V1 H1 K1 N1 K2 N2 ZF1
(RAF018)	W1 B1 V1 H1 K1 N1 K2 N2 ZF1 S1
(RAF019)	W1 B1 V1 H1 K1 N1 K2 N2 ZF1 S1

BETA	HORIZT	SPLR-L	TRANS
0.000	-1.000	0.000	1.000
0.000	-1.000	-10.000	1.000
0.000	-1.000	-25.000	1.000

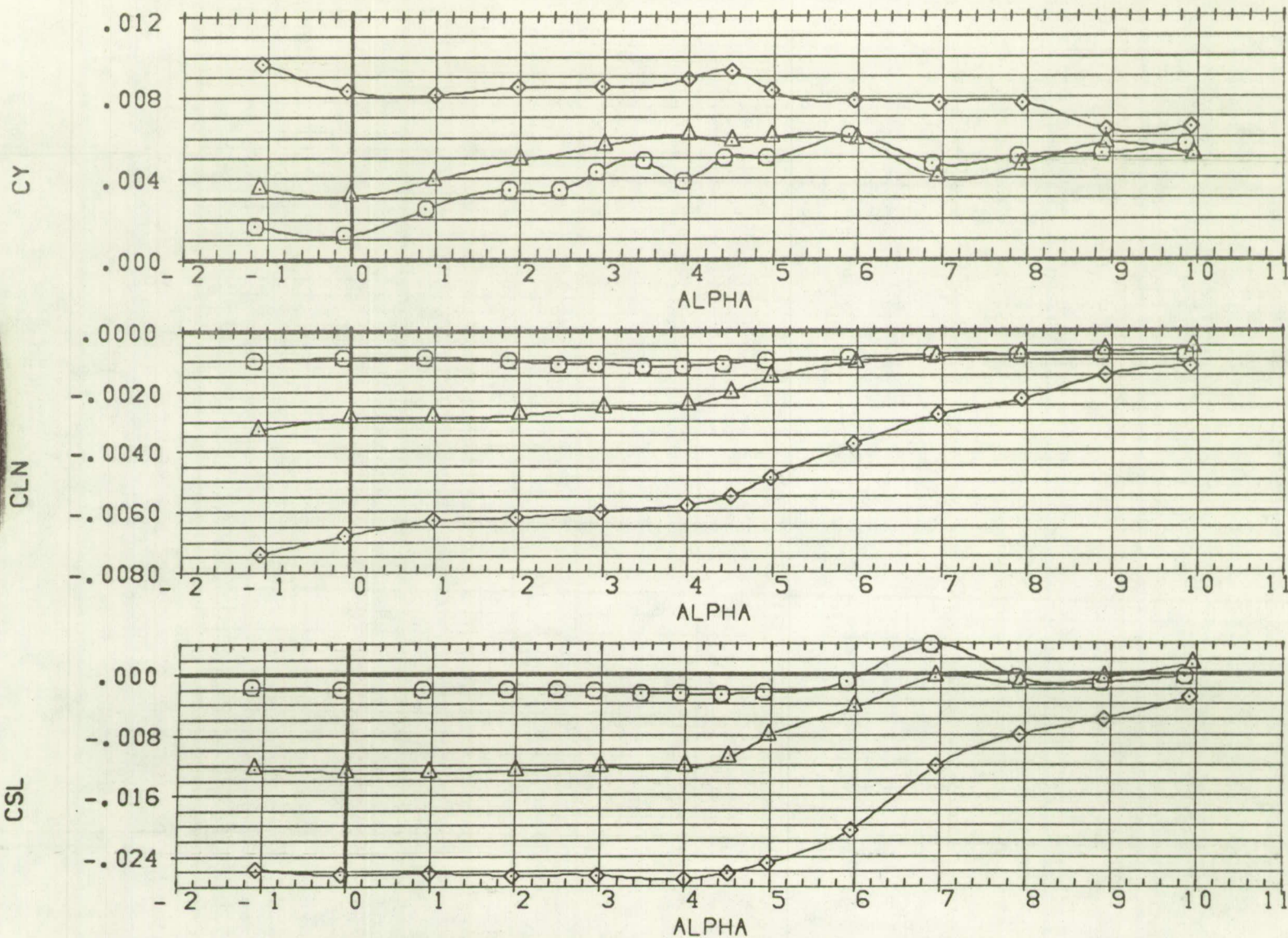

FIG 11 EFFECT OF SPOILER ON LAT-DIR AERODYNAMICS AT BETA= 0
 (B)MACH = 0.90

DATA SET SYMBOL	CONFIGURATION DESCRIPTION
(HAF013)	W1 B1 V1 H1 K1 N1 K2 N2 ZF1
(RAF018)	W1 B1 V1 H1 K1 N1 K2 N2 ZF1 S1
(RAF019)	W1 B1 V1 H1 K1 N1 K2 N2 ZF1 S1

BETA	HORIZT	SPLR-L	TRANS
0.000	-1.000	0.000	1.000
0.000	-1.000	-10.000	1.000
0.000	-1.000	-25.000	1.000

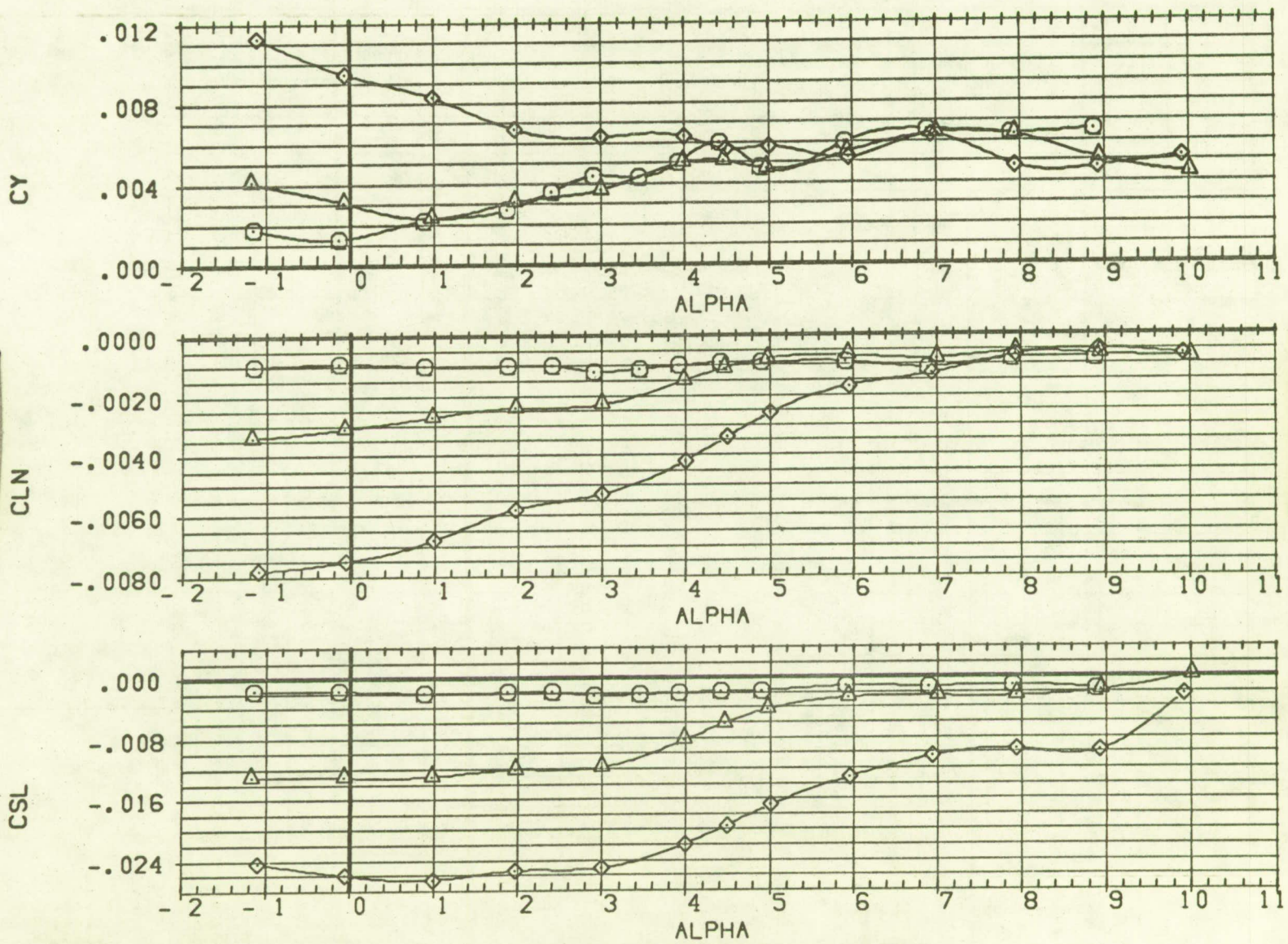

FIG 11 EFFECT OF SPOILER ON LAT-DIR AERODYNAMICS AT BETA= 0

(C)MACH = 0.95

DATA SET SYMBOL	CONFIGURATION DESCRIPTION
(RAFD13)	W1 B1 V1 H1 K1 N1 K2 N2 ZF1
(RAFD21)	W1 B1 K1 N1 K2 N2 ZF1
(RAFD22)	W1 B1 K1 N1 K2 N2
(RAFD24)	W1 B1

BETA	HORIZ	SPLR-L	TRANS
0.000	-1.00	0.000	1.000
0.000		0.000	1.000
0.000		0.000	1.000
0.000		0.000	1.000

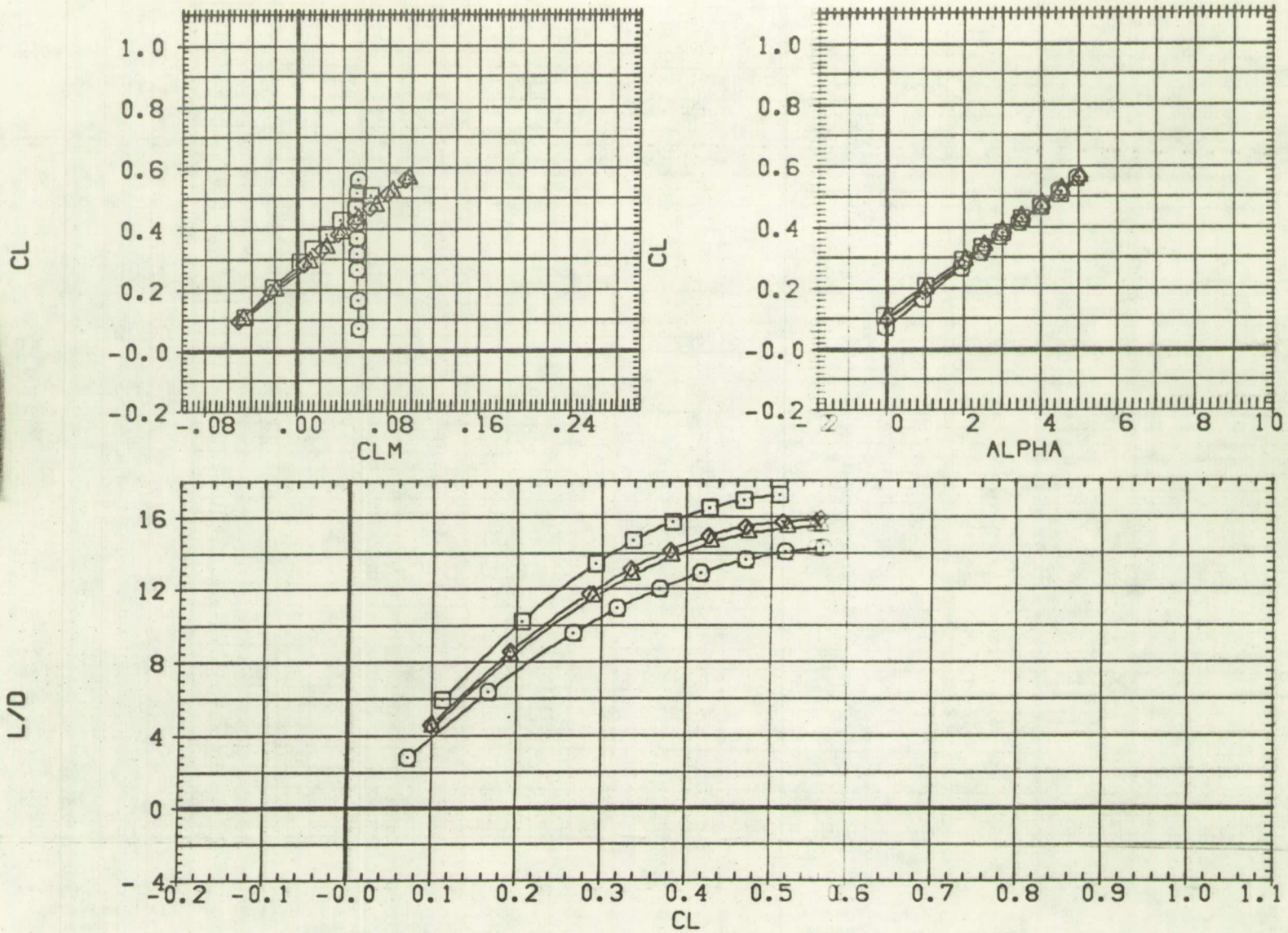

FIG 12 EFFECT OF MODEL COMPONENTS ON LONGITUDINAL AERODYNAMICS

(A)MACH = 0.50

DATA SET SYMBOL	CONFIGURATION DESCRIPTION
(RAFO13)	W1 B1 V1 H1 K1 N1 K2 N2 ZF1
(RAFO21)	W1 B1 K1 N1 K2 N2 ZF1
(RAFO22)	W1 B1 K1 N1 K2 N2
(HAFO24)	W1 B1

BETA	HORIZT	SPLR-L	TRANS
0.000	-1.000	0.000	1.000
0.000		0.000	1.000
0.000		0.000	1.000
0.000		0.000	1.000

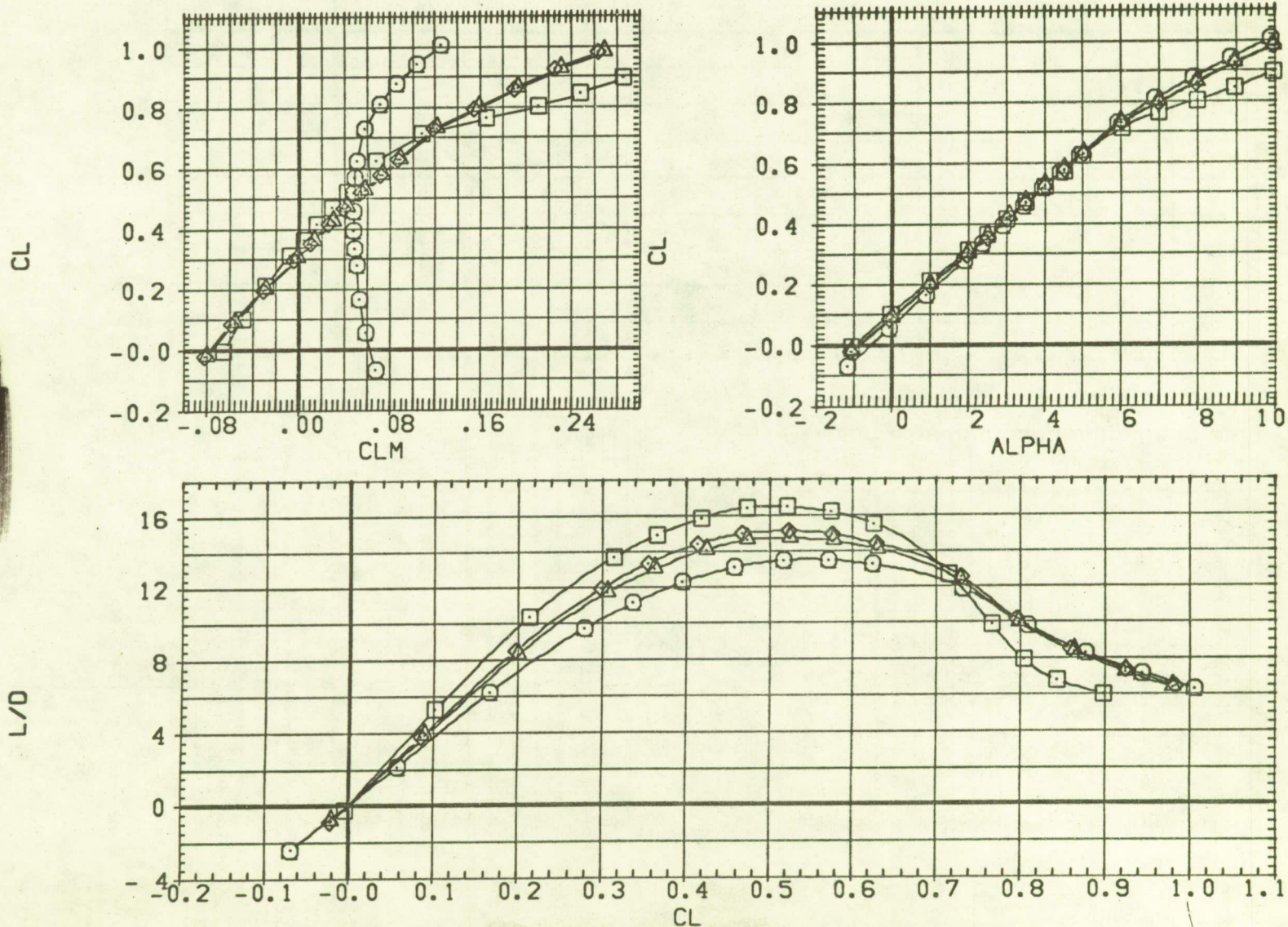
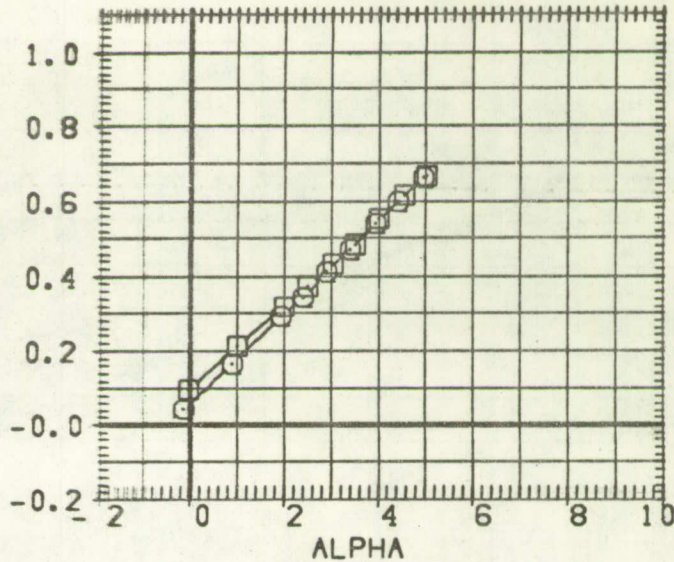
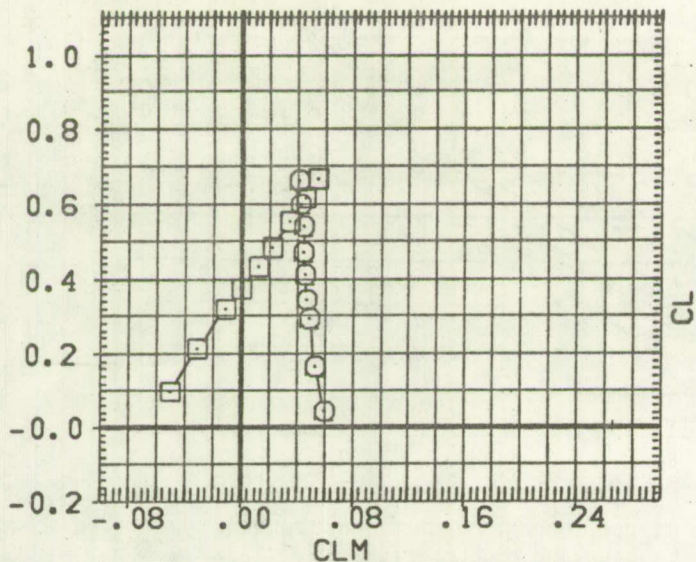

FIG 12 EFFECT OF MODEL COMPONENTS ON LONGITUDINAL AERODYNAMICS

DATA SET SYMBOL	CONFIGURATION DESCRIPTION
(RAF013)	W1 B1 V1 H1 K1 N1 K2 N2 ZF1
(RAF021)	DATA NOT AVAILABLE
(RAF022)	DATA NOT AVAILABLE
(HAF024)	W1 B1

BETA	HORIZT	SPLR-L	TRANS
0.000	-1.000	0.000	1.000
0.000		0.000	1.000
0.000		0.000	1.000
0.000		0.000	1.000

CL



L/D

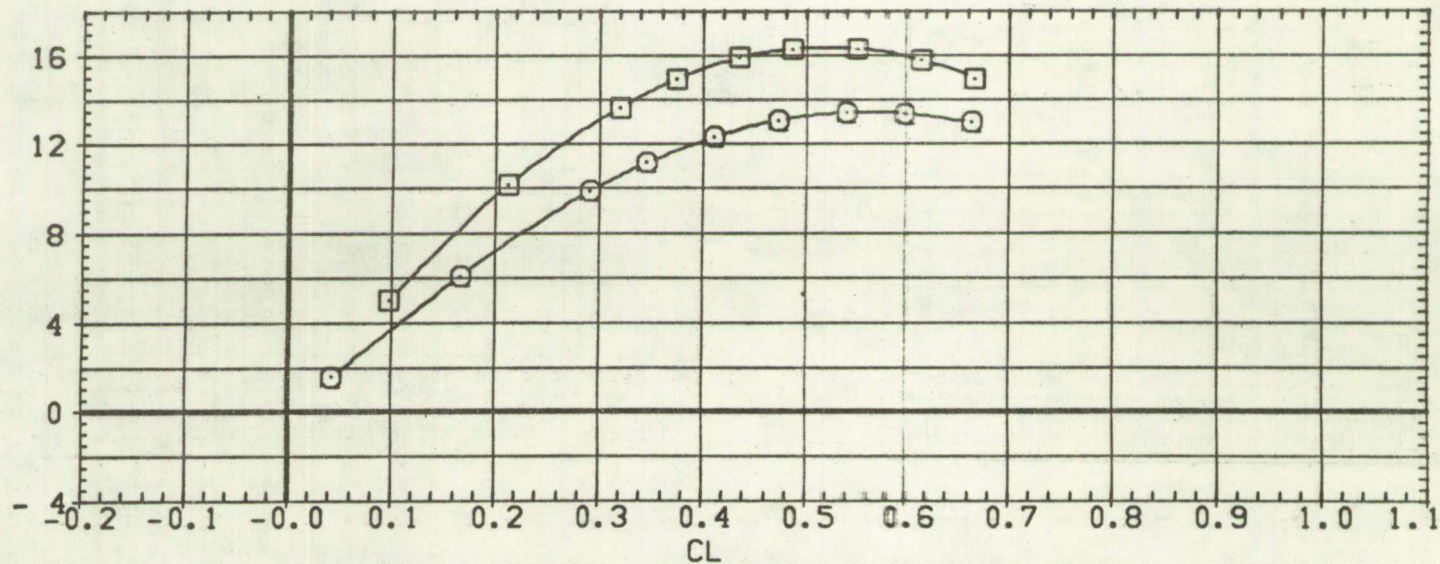

FIG 12 EFFECT OF MODEL COMPONENTS ON LONGITUDINAL AERODYNAMICS
(C)MACH = 0.85

DATA SET SYMBOL	CONFIGURATION DESCRIPTION
(RAFD13)	W1 B1 V1 H1 K1 N1 K2 N2 ZF1
(RAFD21)	W1 B1 K1 N1 K2 N2 ZF1
(RAFD22)	W1 B1 K1 N1 K2 N2
(RAFD24)	W1 B1

BETA	HORIZT	SPLR-L	TRANS
0.000	-1.000	0.000	1.000
0.000		0.000	1.000
0.000		0.000	1.000
0.000		0.000	1.000

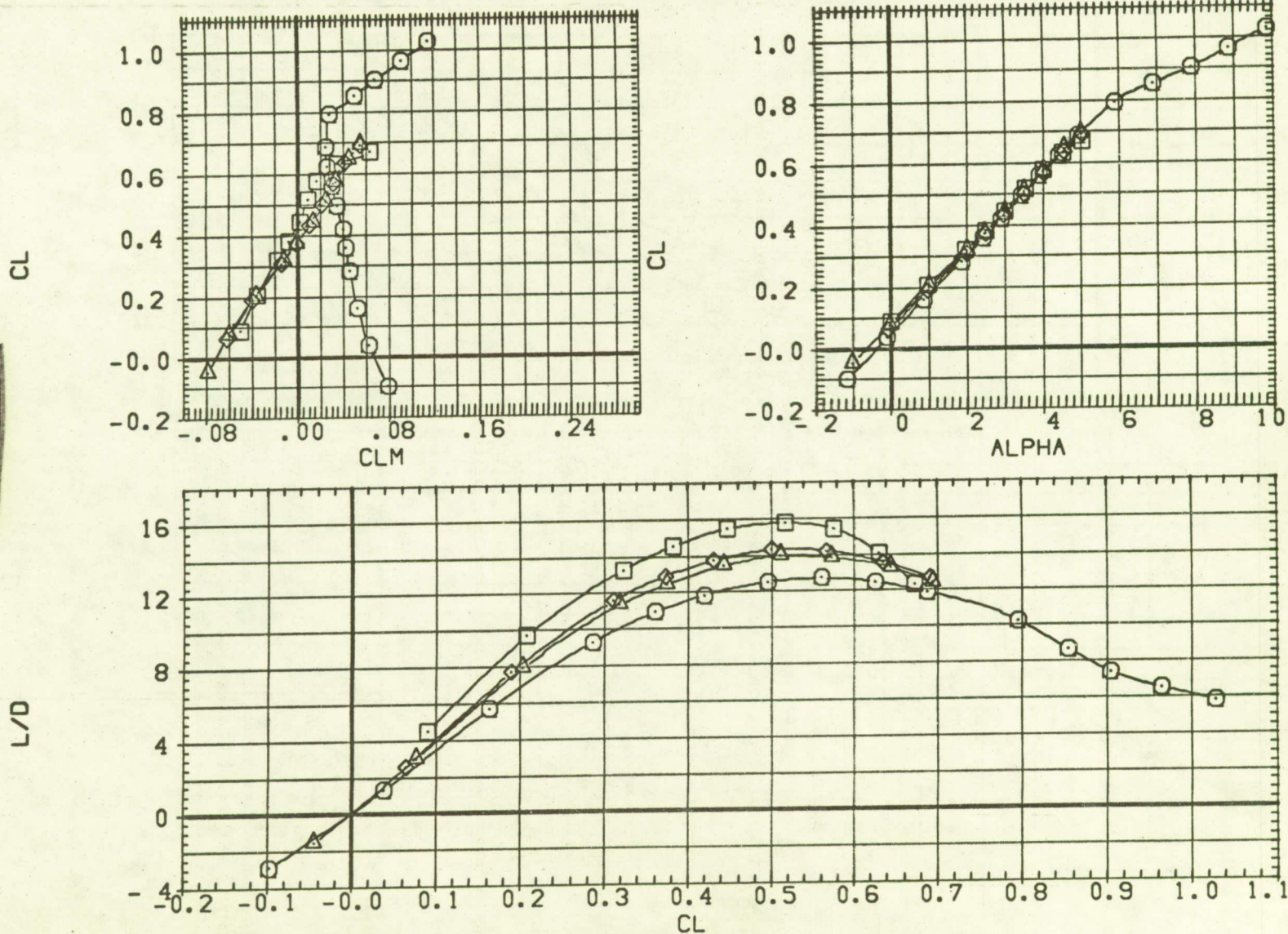

FIG 12 EFFECT OF MODEL COMPONENTS ON LONGITUDINAL AERODYNAMICS

(M)MACH = 0.90

DATA SET SYMBOL	CONFIGURATION DESCRIPTION
(RAFD13)	W1 B1 V1 H1 K1 N1 K2 N2 ZF1
(RAFD21)	W1 B1 K1 N1 K2 N2 ZF1
(RAFD22)	W1 B1 K1 N1 K2 N2
(HAFD24)	W1 B1

BETA	HORIZT	SPLR-L	TRANS
0.000	-1.000	0.000	1.000
0.000		0.000	1.000
0.000		0.000	1.000
0.000		0.000	1.000

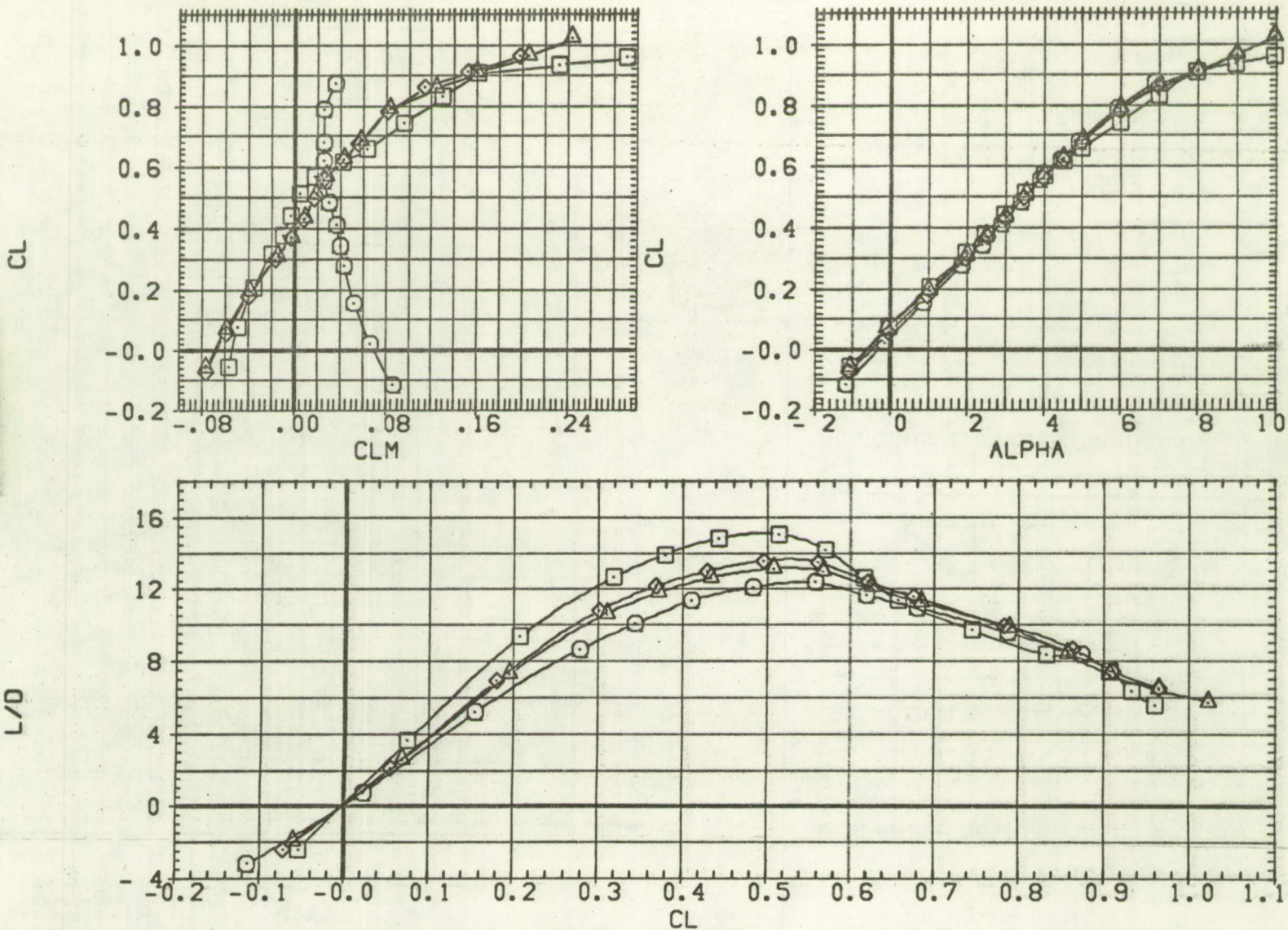

FIG 12 EFFECT OF MODEL COMPONENTS ON LONGITUDINAL AERODYNAMICS
(E)MACH = 0.92

DATA SET SYMBOL	CONFIGURATION DESCRIPTION
(RAF013)	W1 B1 V1 H1 K1 N1 K2 N2 ZF1
(RAF021)	W1 B1 K1 N1 K2 N2 ZF1
(RAF022)	W1 B1 K1 N1 K2 N2
(HAF024)	W1 B1

BETA	HORIZT	SPLR-L	TRANS
0.000	-1.000	0.000	1.000
0.000		0.000	1.000
0.000		0.000	1.000
0.000		0.000	1.000

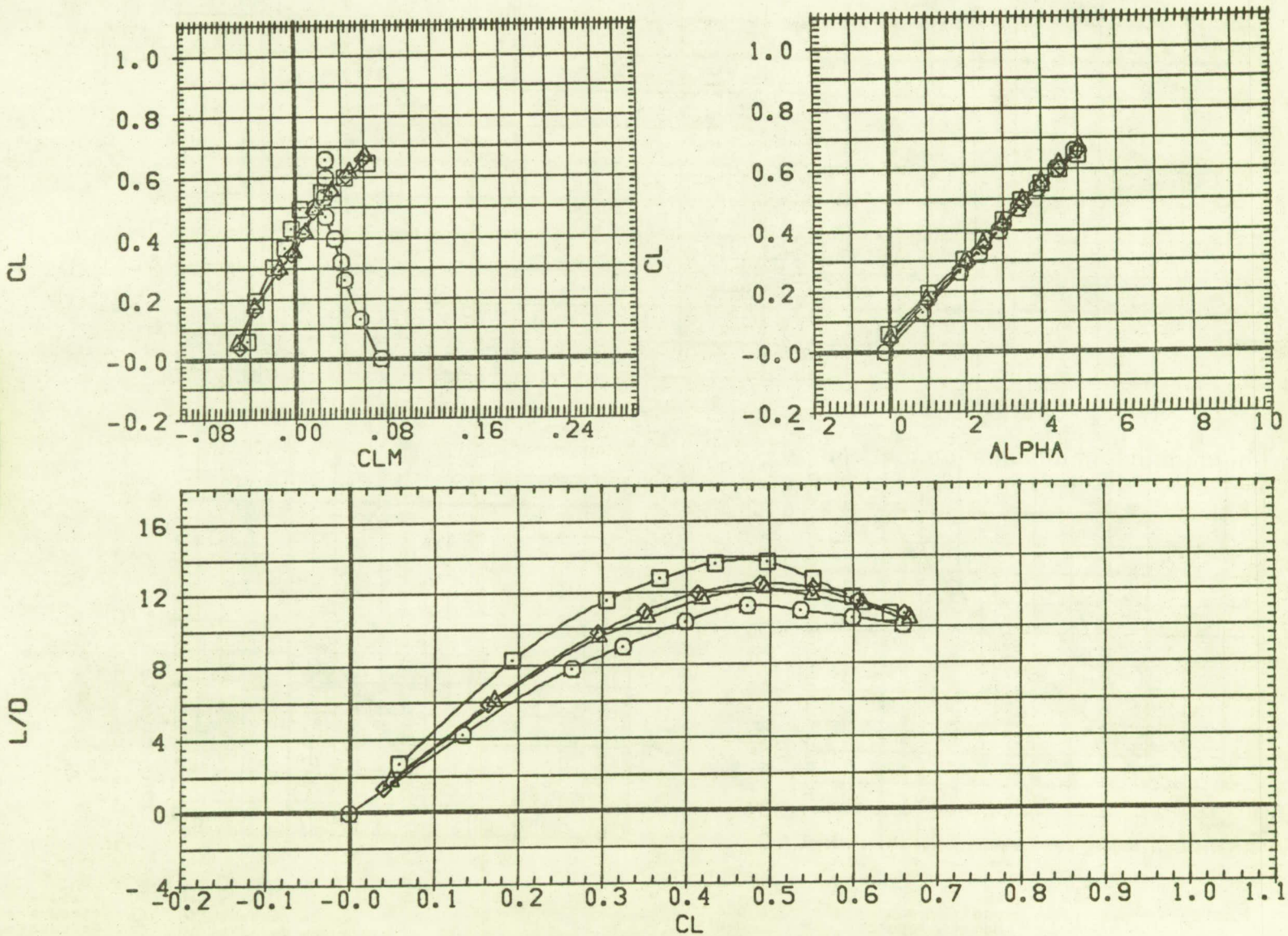

FIG 12 EFFECT OF MODEL COMPONENTS ON LONGITUDINAL AERODYNAMICS
(F)MACH = 0.94

DATA SET SYMBOL	CONFIGURATION DESCRIPTION
(RAFD13)	W1 B1 V1 H1 K1 N1 K2 N2 ZF1
(RAFD21)	W1 B1 K1 N1 K2 N2 ZF1
(RAFD22)	W1 B1 K1 N1 K2 N2
(HAFD24)	W1 B1

BETA	HORIZT	SPLR-L	TRANS
0.000	-1.000	0.000	1.000
0.000		0.000	1.000
0.000		0.000	1.000
0.000		0.000	1.000

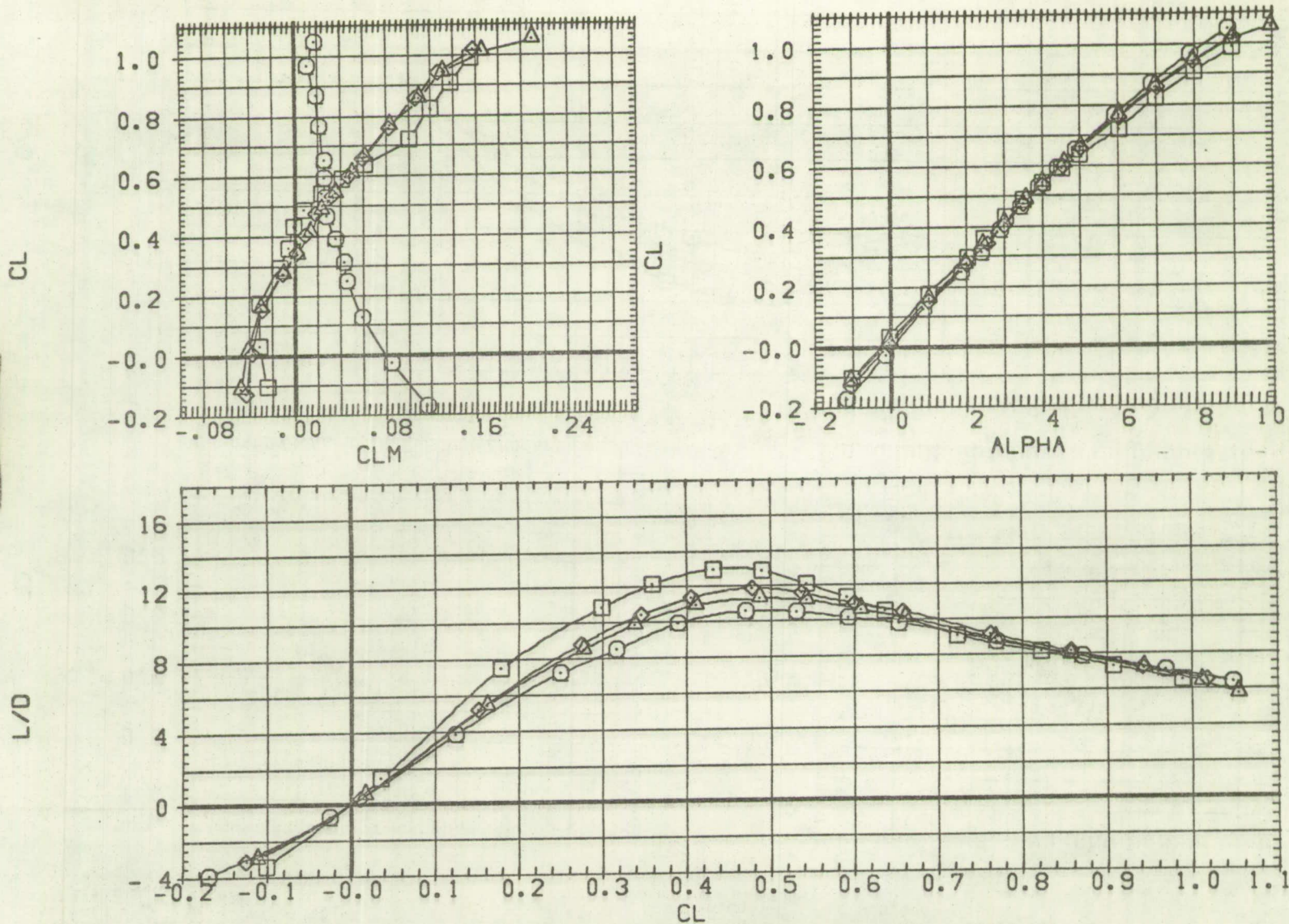

FIG 12 EFFECT OF MODEL COMPONENTS ON LONGITUDINAL AERODYNAMICS
(G)MACH = 0.95

DATA SET SYMBOL	CONFIGURATION DESCRIPTION
(RAFD13)	DATA NOT AVAILABLE
(RAFD21)	W1 B1 K1 N1 K2 N2 ZF1
(RAFD22)	W1 B1 K1 N1 K2 N2
(HAFD24)	W1 B1

BETA	HORIZT	SPLR-L	TRANS
0.000	-1.000	0.000	1.000
0.000		0.000	1.000
0.000		0.000	1.000
0.000		0.000	1.000

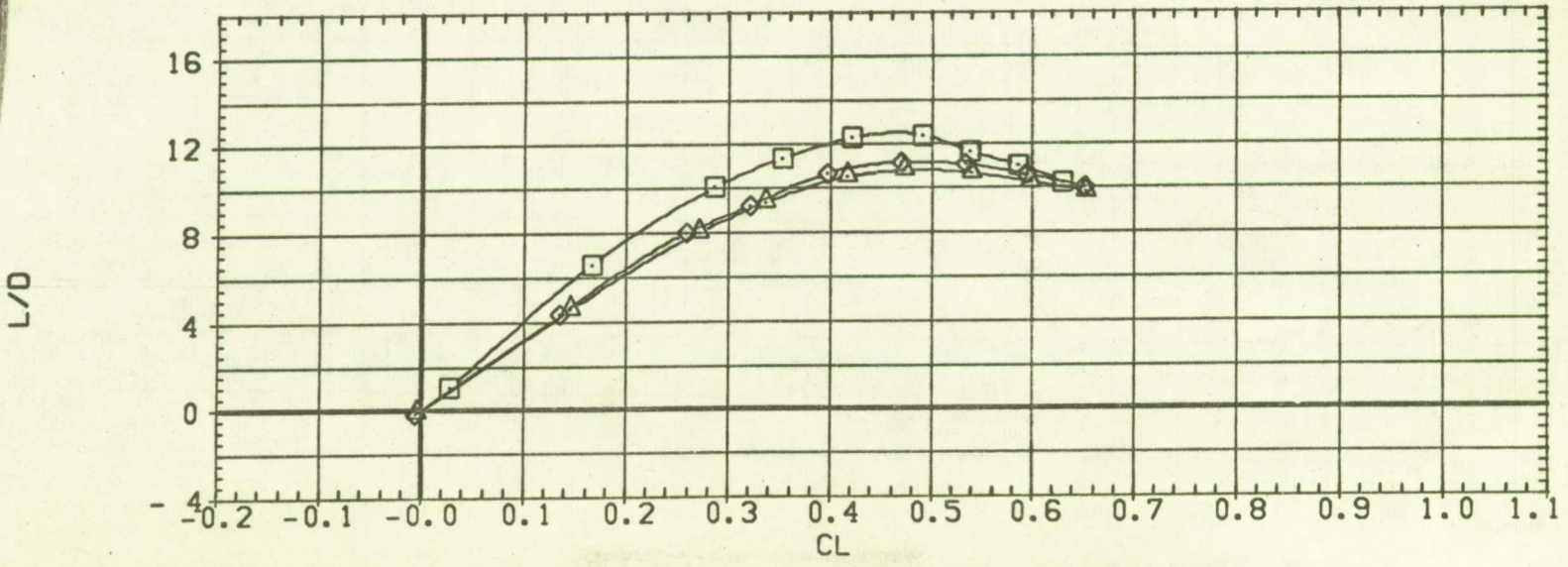
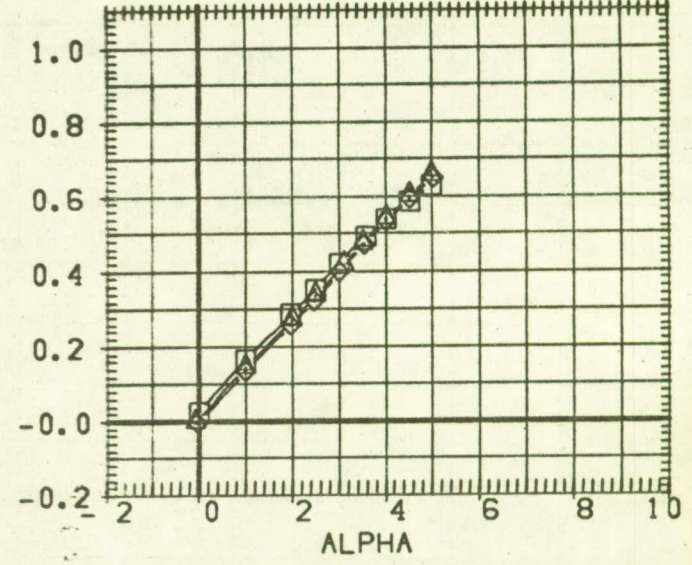
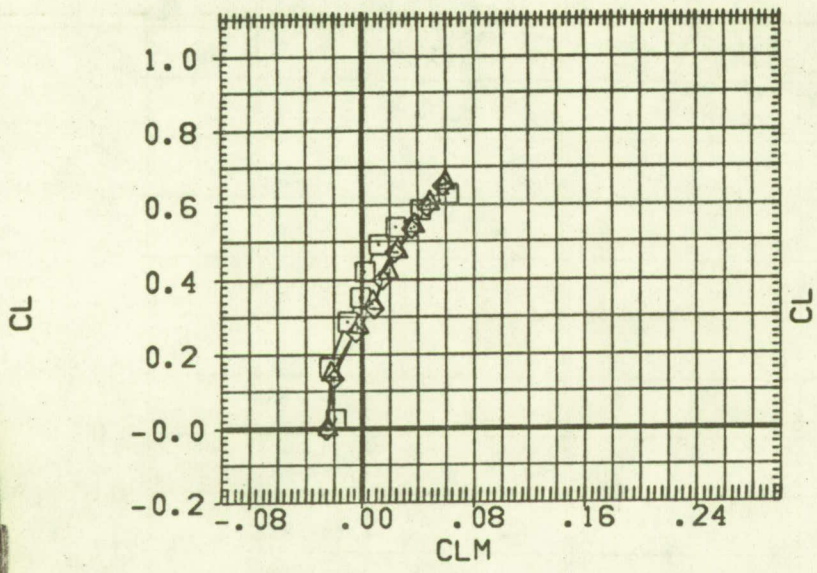

FIG 12 EFFECT OF MODEL COMPONENTS ON LONGITUDINAL AERODYNAMICS

(M)MACH = 0.96

DATA SET	SYMBOL	CONFIGURATION DESCRIPTION
(RAFD13)	○	W1 B1 V1 H1 K1 N1 K2 N2 ZF1
(RAFD21)	△	W1 B1 K1 N1 K2 N2 ZF1
(RAFD22)	◇	W1 B1 K1 N1 K2 N2
(HAF024)	□	W1 B1

BETA	HORIZT	SPLR-L	TRANS
0.000	-1.000	0.000	1.000
0.000		0.000	1.000
0.000		0.000	1.000
0.000		0.000	1.000

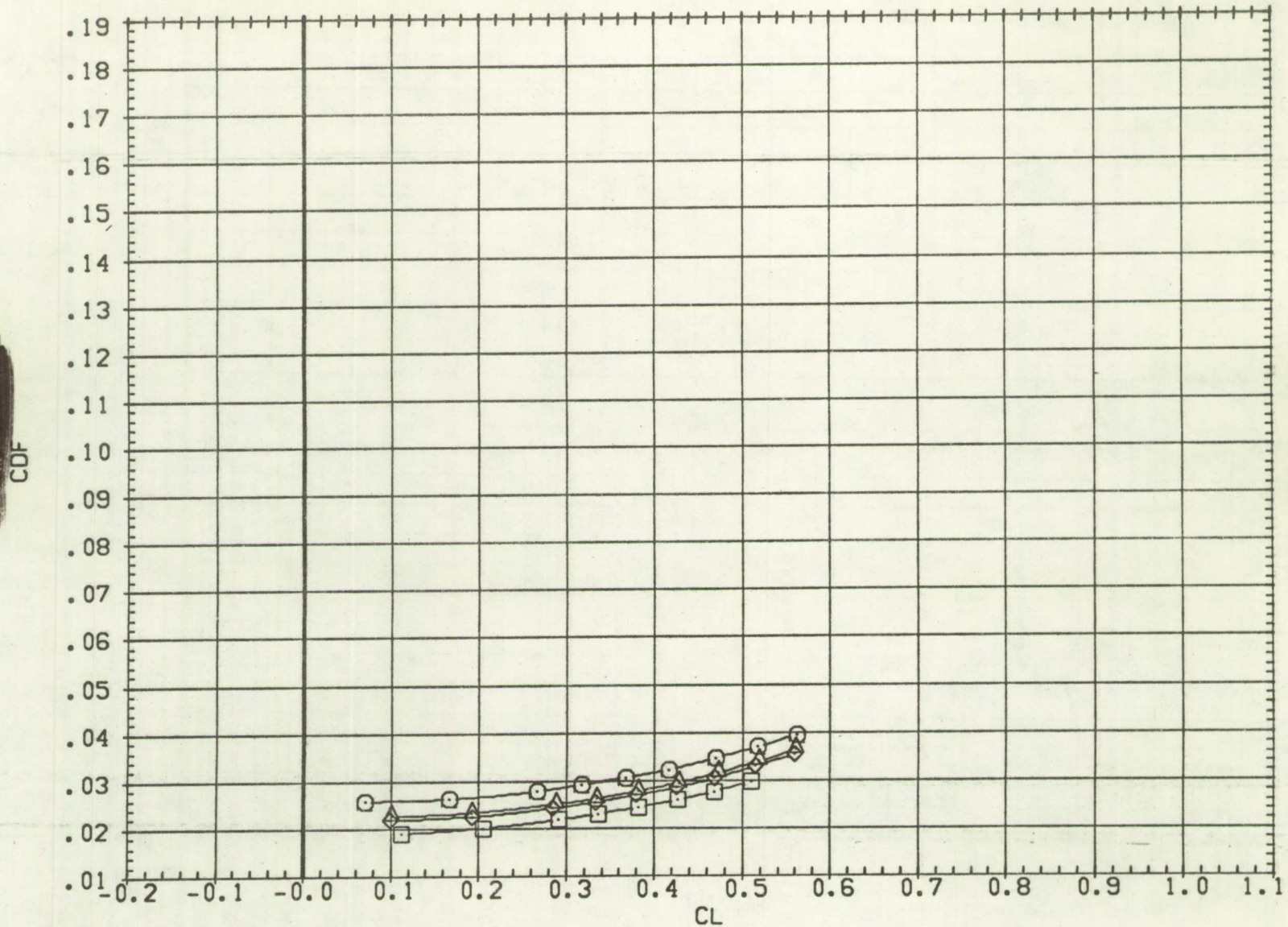

FIG 12 EFFECT OF MODEL COMPONENTS ON LONGITUDINAL AERODYNAMICS
 (A) MACH = 0.50

DATA SET SYMBOL	CONFIGURATION DESCRIPTION
(RAF013)	○ W1 B1 V1 H1 K1 N1 K2 N2 ZF1
(RAF021)	◇ W1 B1 K1 N1 K2 N2 ZF1
(RAF022)	△ W1 B1 K1 N1 K2 N2
(HAF024)	□ W1 B1

BETA	HORIZT	SPLR-L	TRANS
0.000	-1.000	0.000	1.000
0.000		0.000	1.000
0.000		0.000	1.000
0.000		0.000	1.000

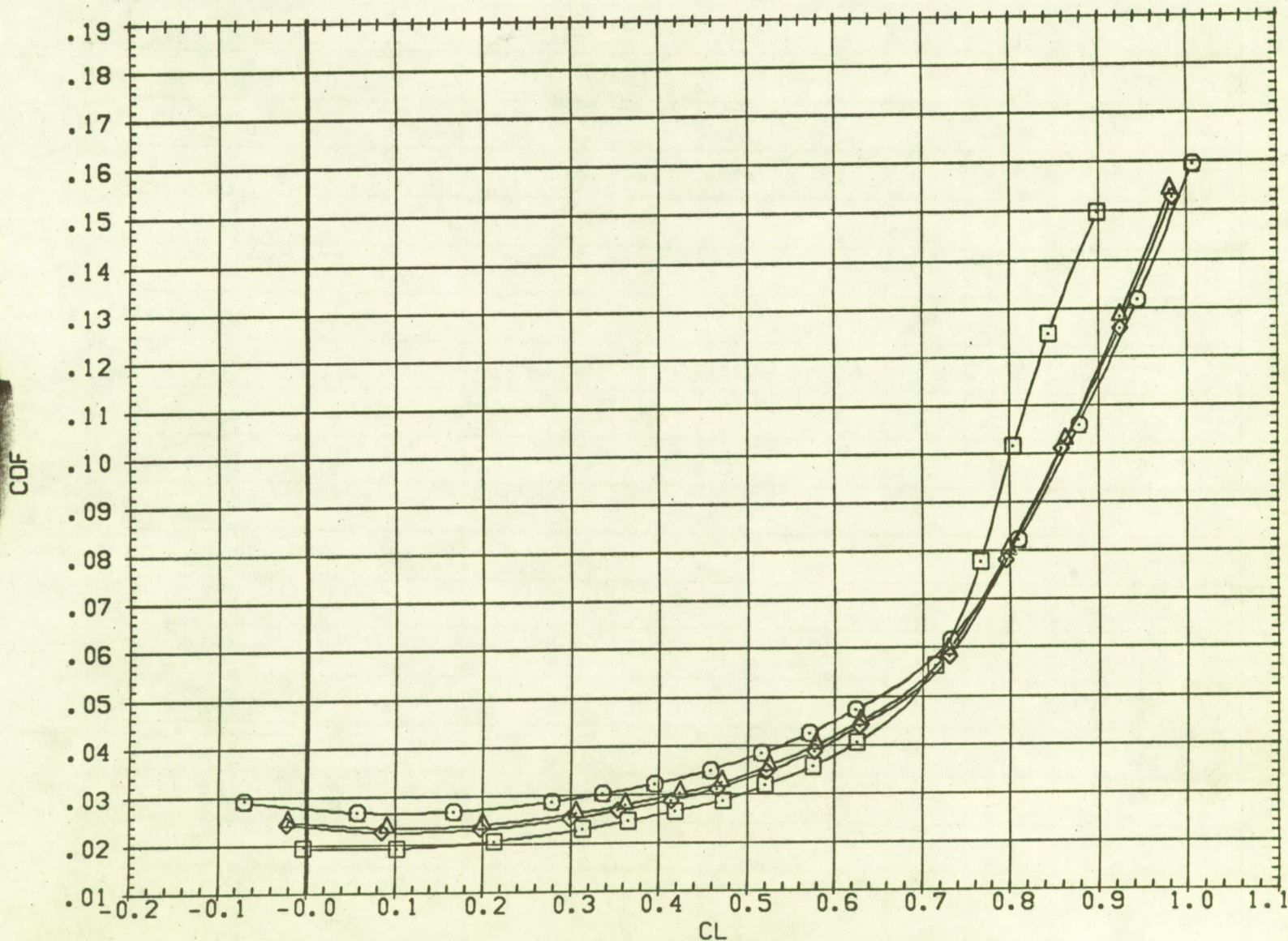

FIG 12 EFFECT OF MODEL COMPONENTS ON LONGITUDINAL AERODYNAMICS

(B)MACH = 0.80

DATA SET SYMBOL	CONFIGURATION DESCRIPTION
(RAF013)	W1 B1 V1 H1 K1 N1 K2 N2 ZF1
(RAF021)	DATA NOT AVAILABLE
(RAF022)	DATA NOT AVAILABLE
(HAF024)	W1 B1

BETA	HORIZT	SPLR-L	TRANS
0.000	-1.000	0.000	1.000
0.000		0.000	1.000
0.000		0.000	1.000
0.000		0.000	1.000

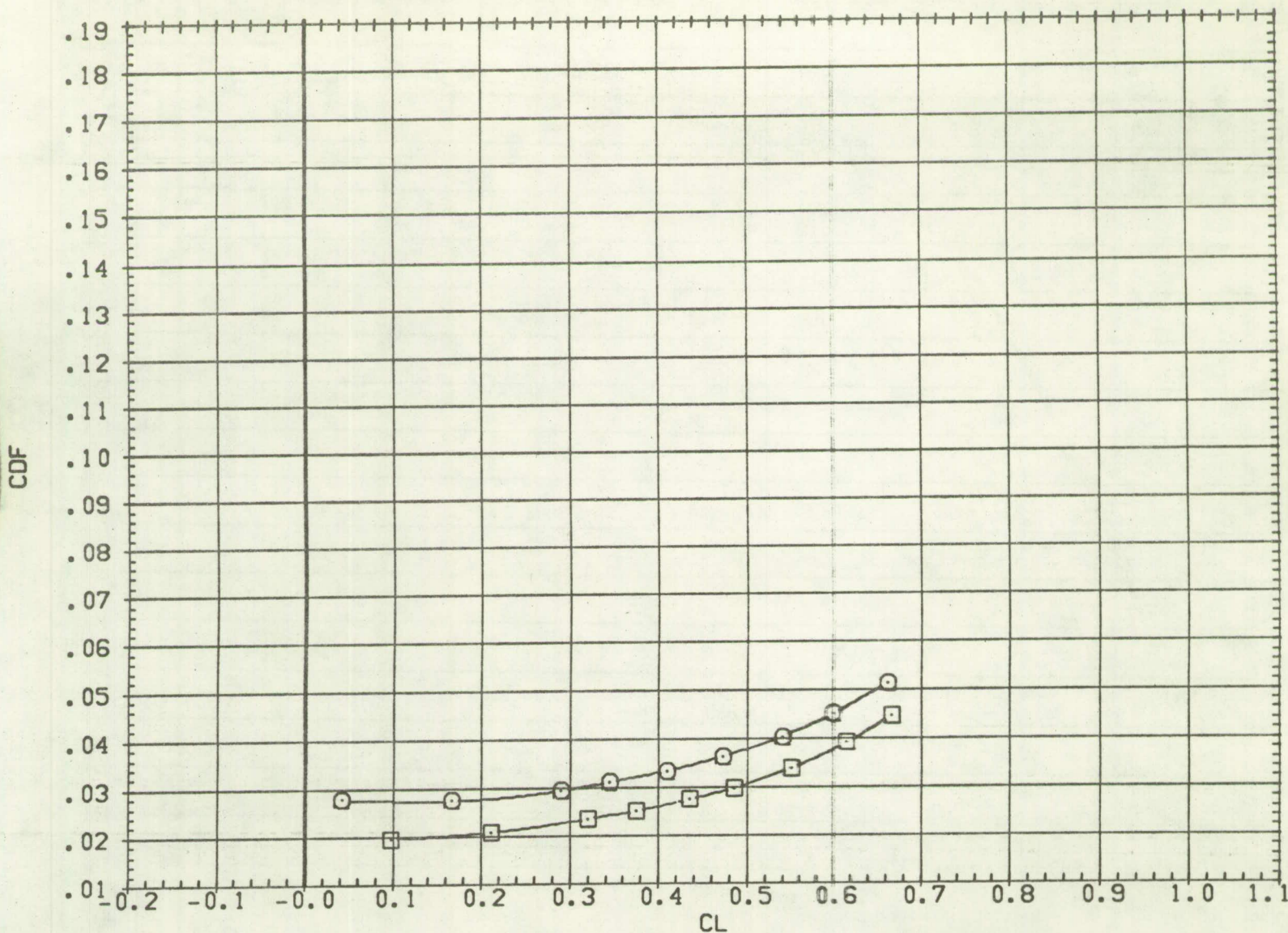

FIG 12 EFFECT OF MODEL COMPONENTS ON LONGITUDINAL AERODYNAMICS

(C)MACH = 0.85

DATA SET SYMBOL	CONFIGURATION DESCRIPTION
(RAFD13)	W1 B1 V1 H1 K1 N1 K2 N2 ZF1
(RAFD21)	W1 B1 K1 N1 K2 N2 ZF1
(RAFD22)	W1 B1 K1 N1 K2 N2
(RAFD24)	W1 B1

BETA	HORIZT	SPLR-L	TRANS
0.000	-1.000	0.000	1.000
0.000		0.000	1.000
0.000		0.000	1.000
0.000		0.000	1.000

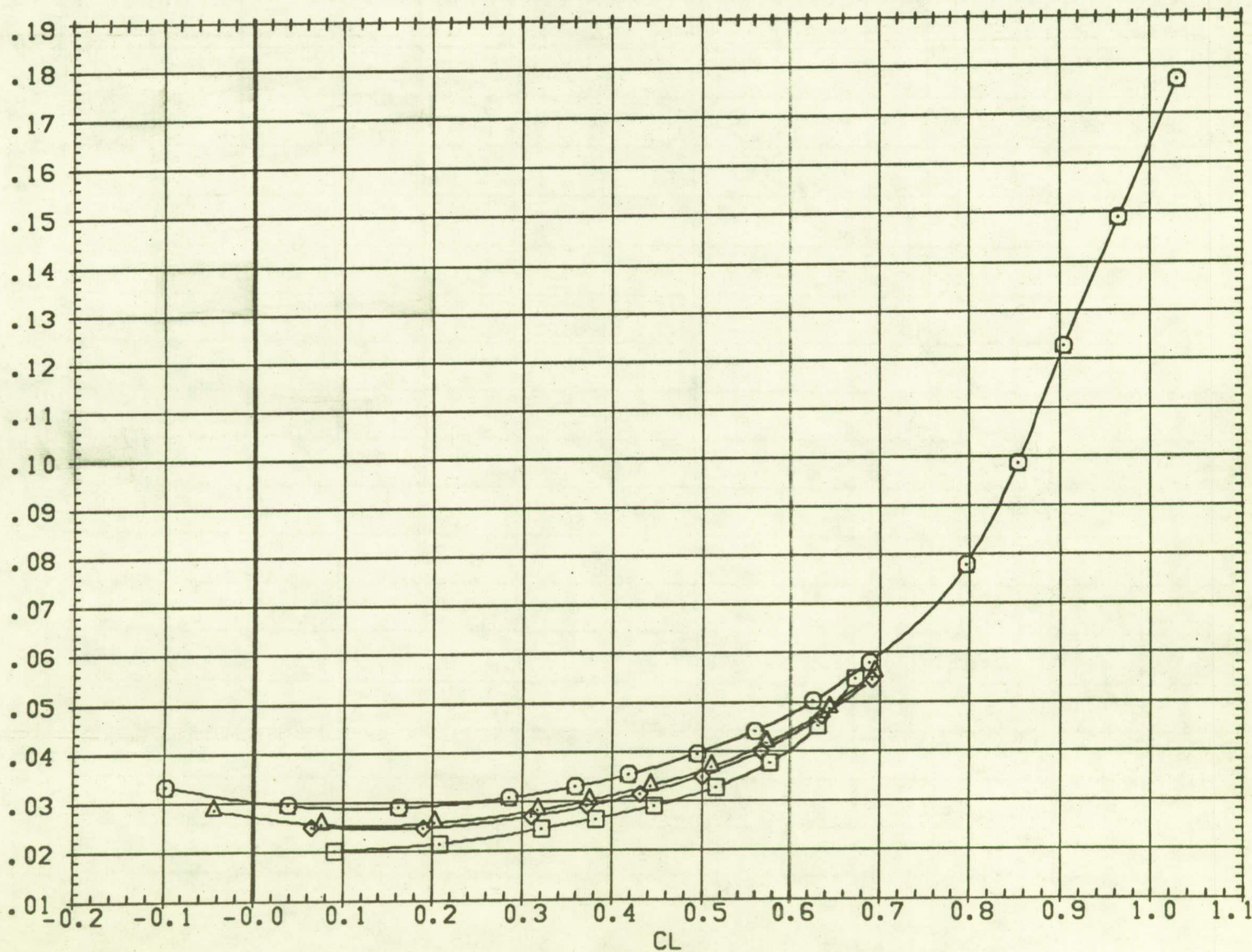

FIG 12 EFFECT OF MODEL COMPONENTS ON LONGITUDINAL AERODYNAMICS

(D)MACH = 0.90

DATA SET SYMBOL	CONFIGURATION DESCRIPTION
(RAFO13)	W1 B1 V1 H1 K1 N1 K2 N2 ZF1
(RAFO21)	W1 B1 K1 N1 K2 N2 ZF1
(RAFO22)	W1 B1 K1 N1 K2 N2
(HAFO24)	W1 B1

BETA	HORIZT	SPLR-L	TRANS
0.000	-1.000	0.000	1.000
0.000		0.000	1.000
0.000		0.000	1.000
0.000		0.000	1.000

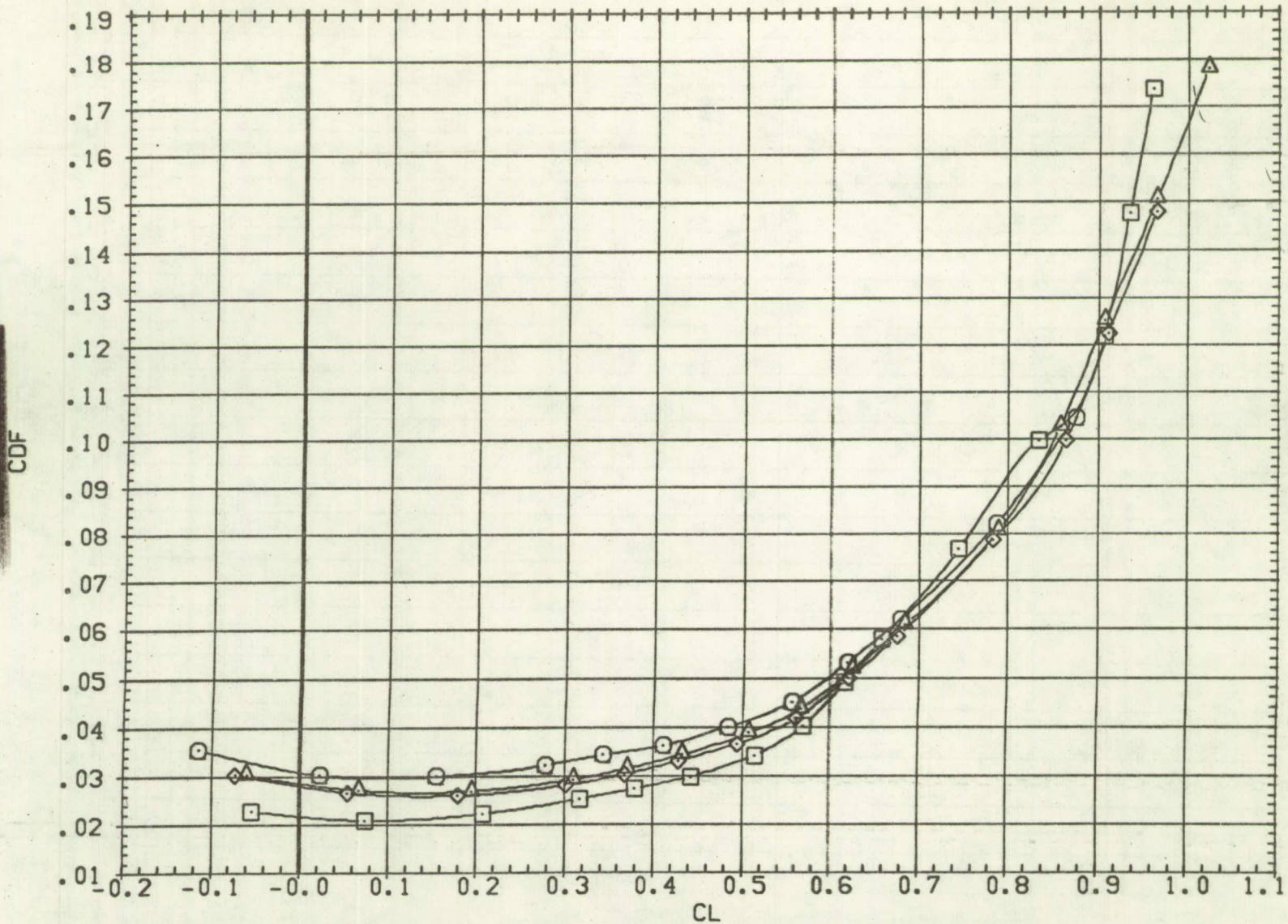

FIG 12 EFFECT OF MODEL COMPONENTS ON LONGITUDINAL AERODYNAMICS
 (E)MACH = 0.92

DATA SET SYMBOL	CONFIGURATION DESCRIPTION
(RAFO13)	W1 B1 V1 H1 K1 N1 K2 N2 ZF1
(RAFO21)	W1 B1 K1 N1 K2 N2 ZF1
(RAFO22)	W1 B1 K1 N1 K2 N2
(HAFO24)	W1 B1

BETA	HORIZT	SPLR-L	TRANS
0.000	-1.000	0.000	1.000
0.000		0.000	1.000
0.000		0.000	1.000
0.000		0.000	1.000

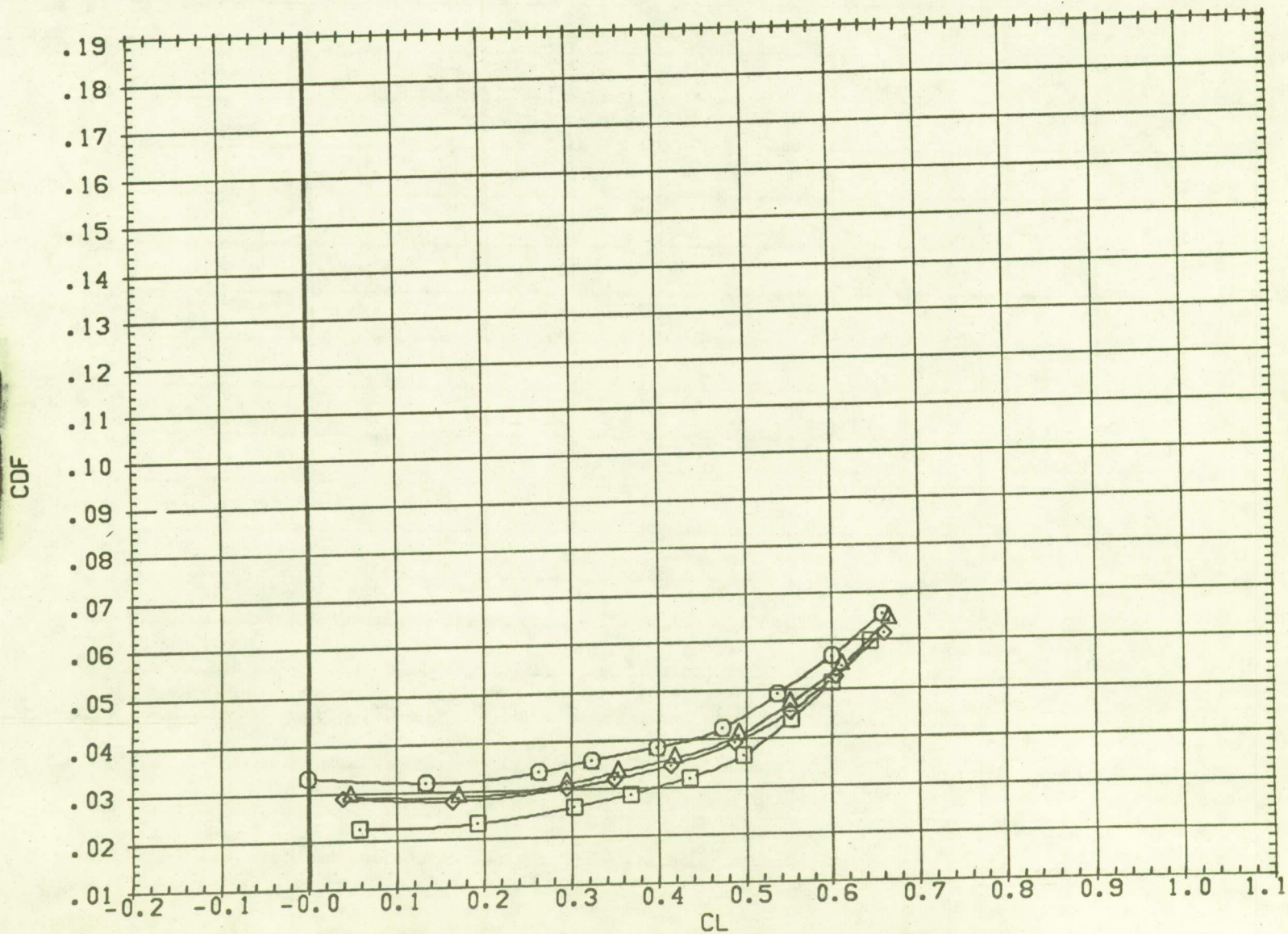

FIG 12 EFFECT OF MODEL COMPONENTS ON LONGITUDINAL AERODYNAMICS

(F)MACH = 0.94

DATA SET	SYMBOL	CONFIGURATION DESCRIPTION
(RAF013)	○	W1 B1 V1 H1 K1 N1 K2 N2 ZF1
(RAF021)	△	W1 B1 K1 N1 K2 N2 ZF1
(RAF022)	◇	W1 B1 K1 N1 K2 N2
(HAF024)	□	W1 B1

BETA	HORIZT	SPLR-L	TRANS
0.000	-1.000	0.000	1.000
0.000		0.000	1.000
0.000		0.000	1.000
0.000		0.000	1.000

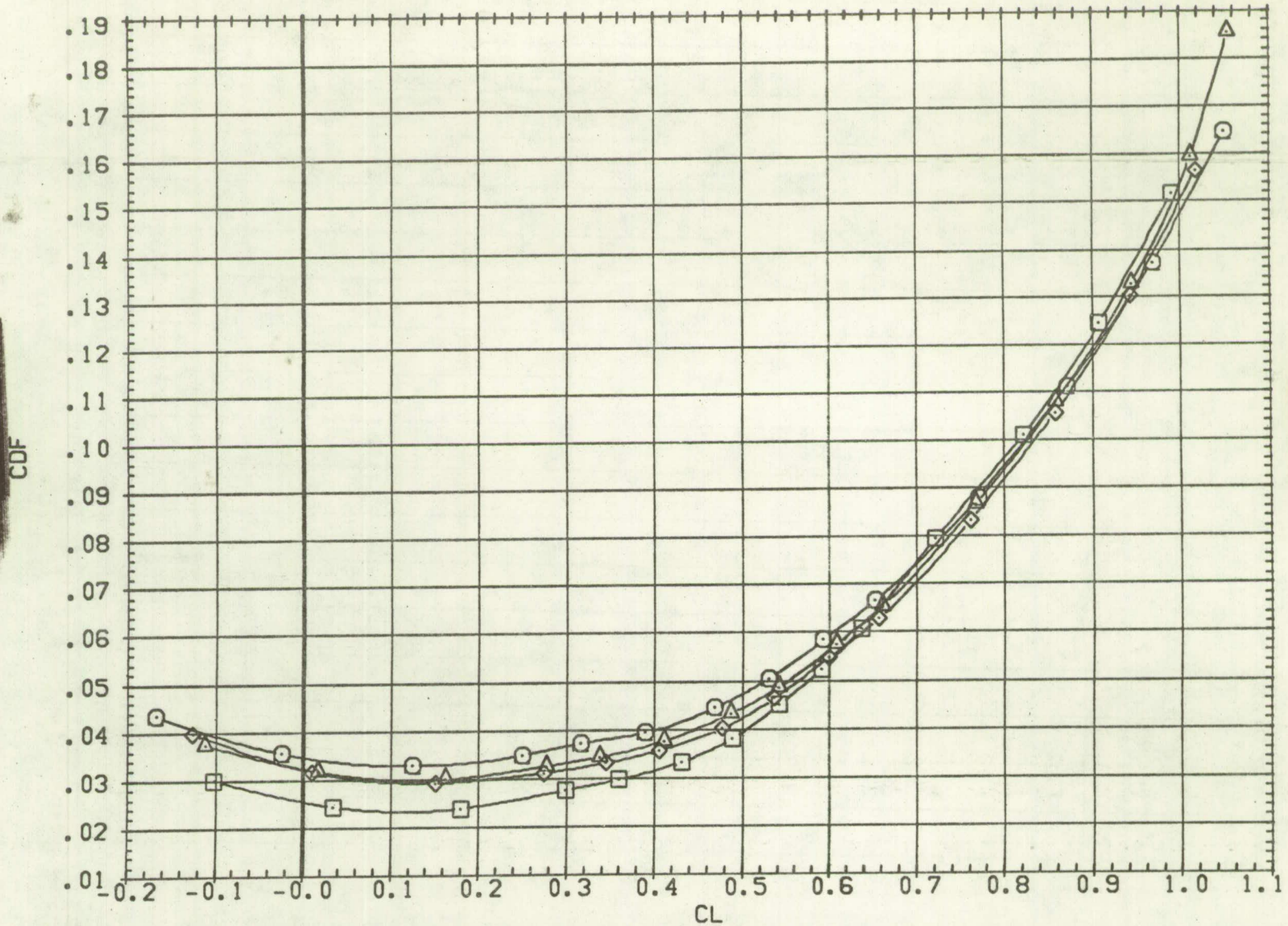

FIG 12 EFFECT OF MODEL COMPONENTS ON LONGITUDINAL AERODYNAMICS
(G)MACH = 0.95

DATA SET SYMBOL	CONFIGURATION DESCRIPTION
(RAFD13)	DATA NOT AVAILABLE
(RAFD21)	W1 B1 K1 N1 K2 N2 ZF1
(RAFD22)	W1 B1 K1 N1 K2 N2
(HAFD24)	W1 B1

BETA	HORIZT	SPLR-L	TRANS
0.000	-1.000	0.000	1.000
0.000		0.000	1.000
0.000		0.000	1.000
0.000		0.000	1.000

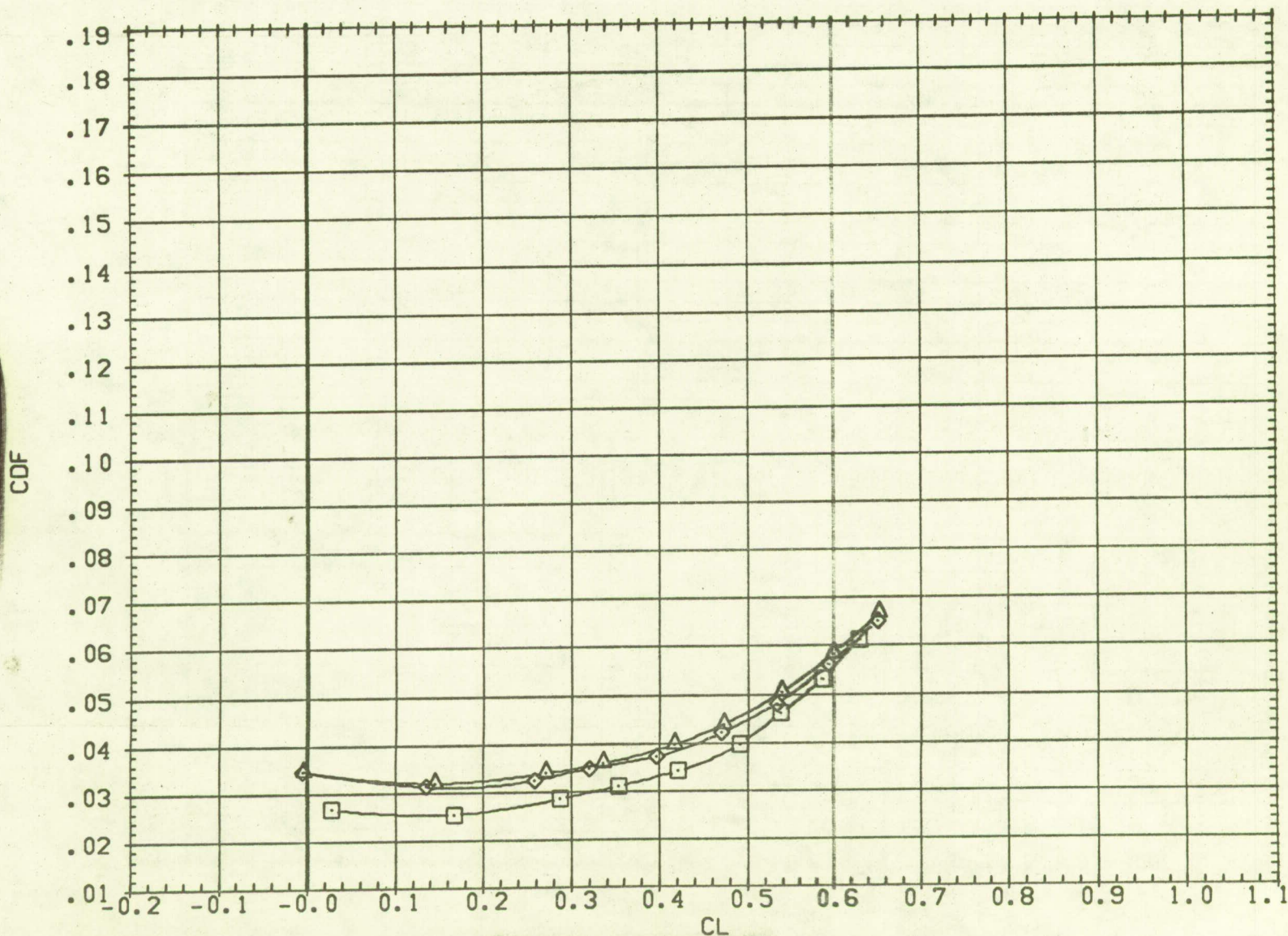

FIG 12 EFFECT OF MODEL COMPONENTS ON LONGITUDINAL AERODYNAMICS

(H)MACH = 0.96

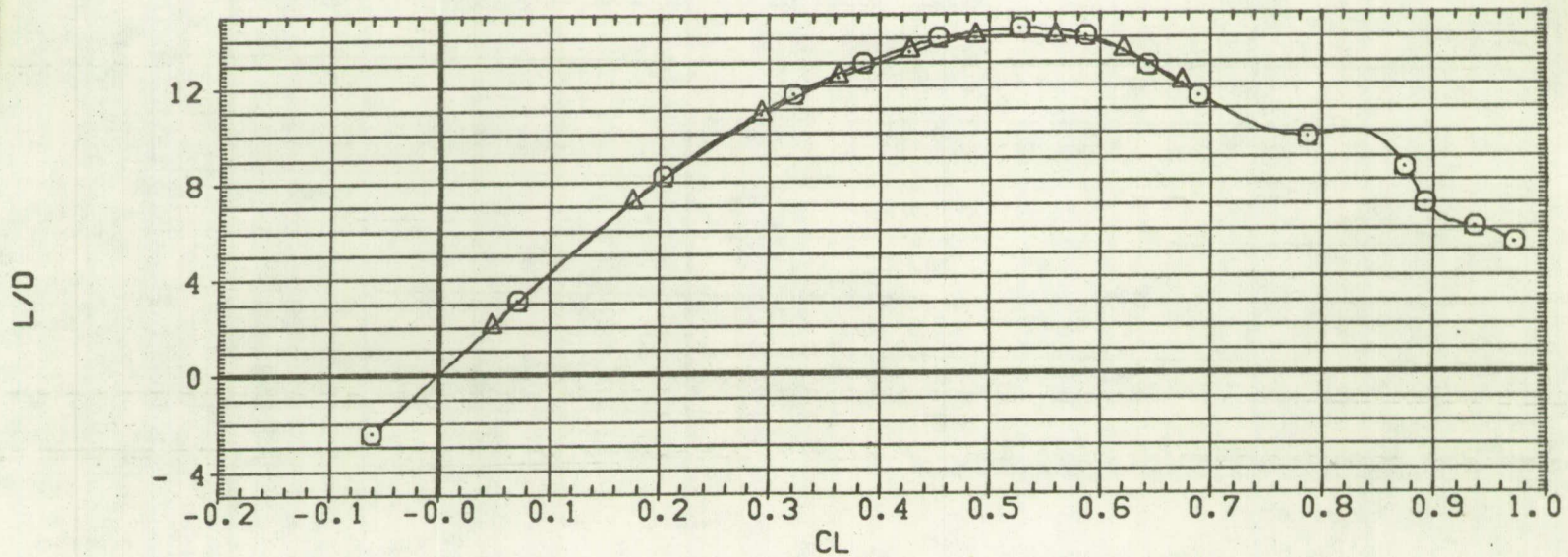
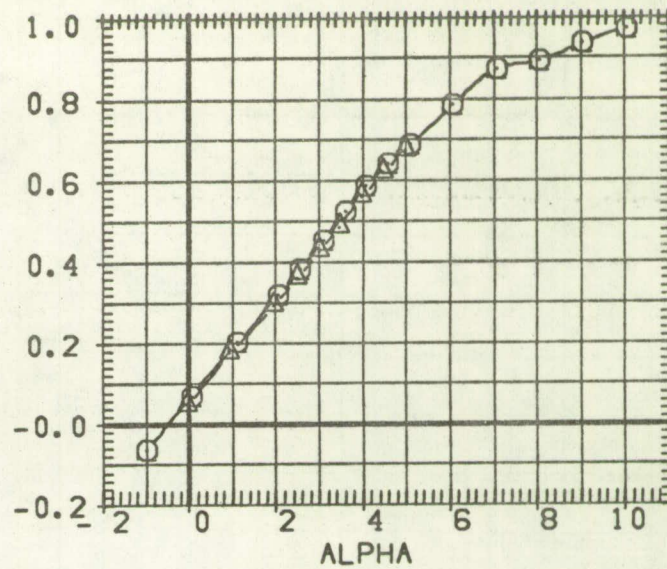
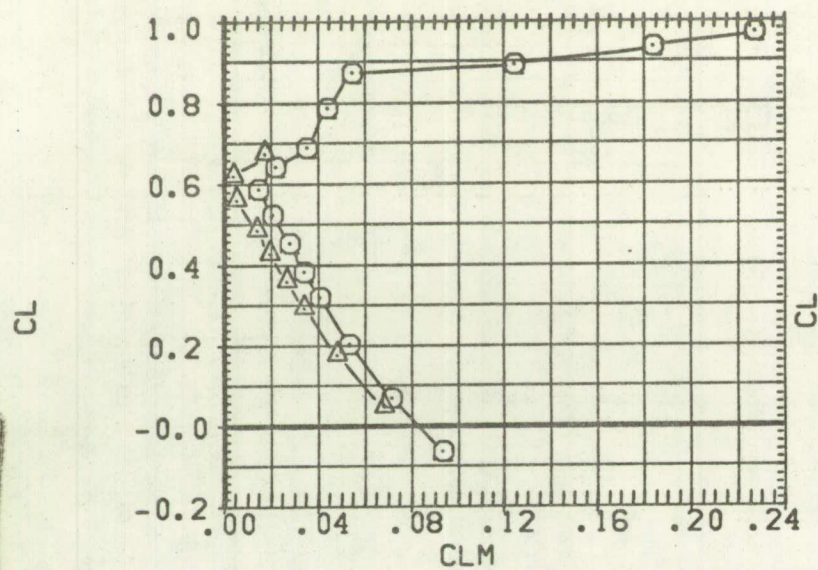

FIG 13 EFFECT OF BODY AREA RULE ON LONGITUDINAL AERODYNAMICS
 (A)MACH = 0.90

DATA SET SYMBOL CONFIGURATION DESCRIPTION
 (XAF007) ○ W1 B1 V1 H1
 (RAF027) △ W1 B3 V1 H1

BETA HORIZT SPLR-L TRANS
 0.000 -1.000 0.000 1.000
 0.000 -1.000 0.000 1.000

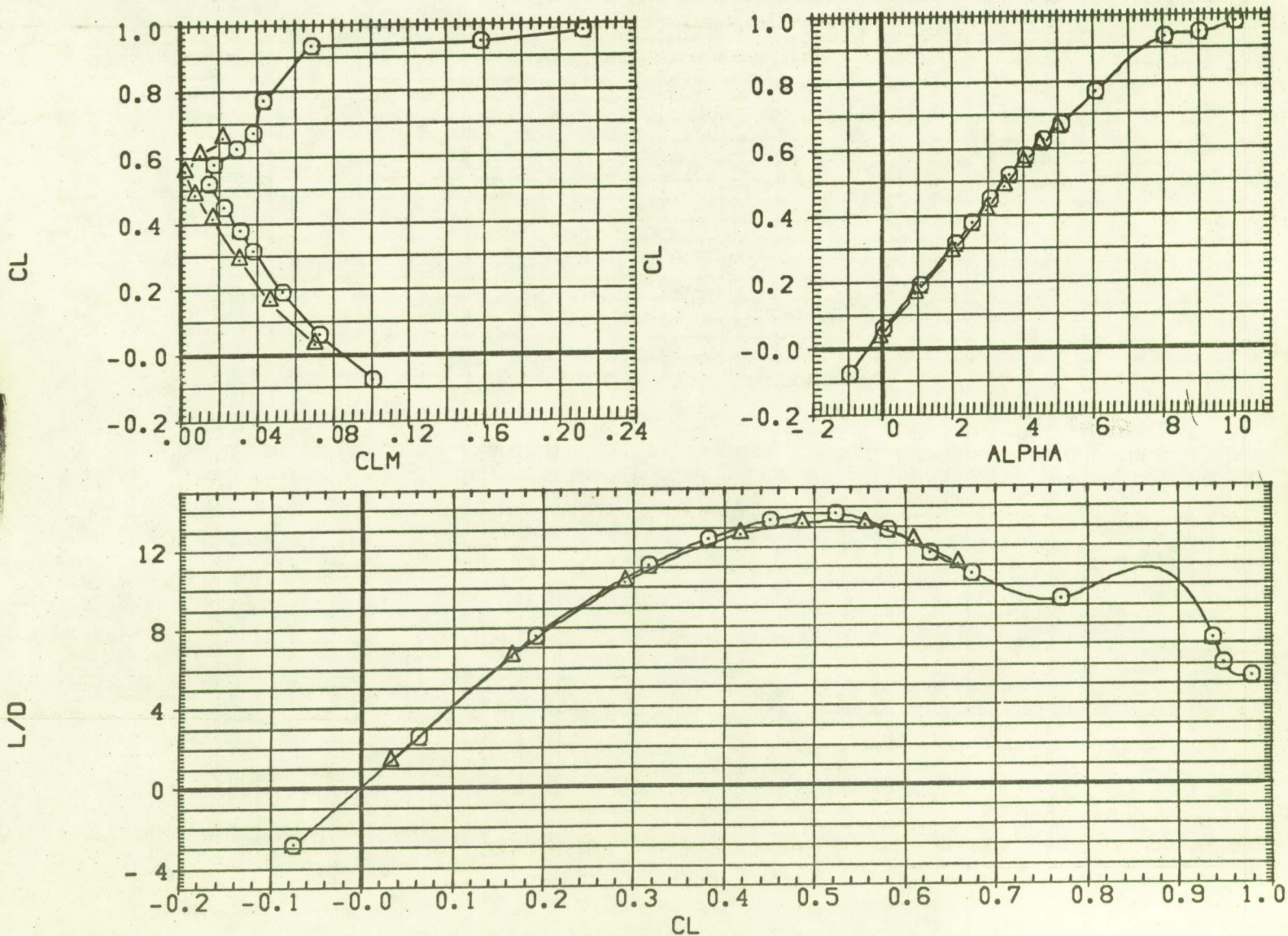

FIG 13 EFFECT OF BODY AREA RULE ON LONGITUDINAL AERODYNAMICS

(B)MACH = 0.92

DATA SET SYMBOL CONFIGURATION DESCRIPTION
 (XAF007) \bigcirc W1 B1 V1 H1
 (RAFG27) \triangle W1 B3 V1 H1

BETA HORIZT SPLR-L TRANS
 0.000 -1.000 0.000 1.000
 0.000 -1.000 0.000 1.000

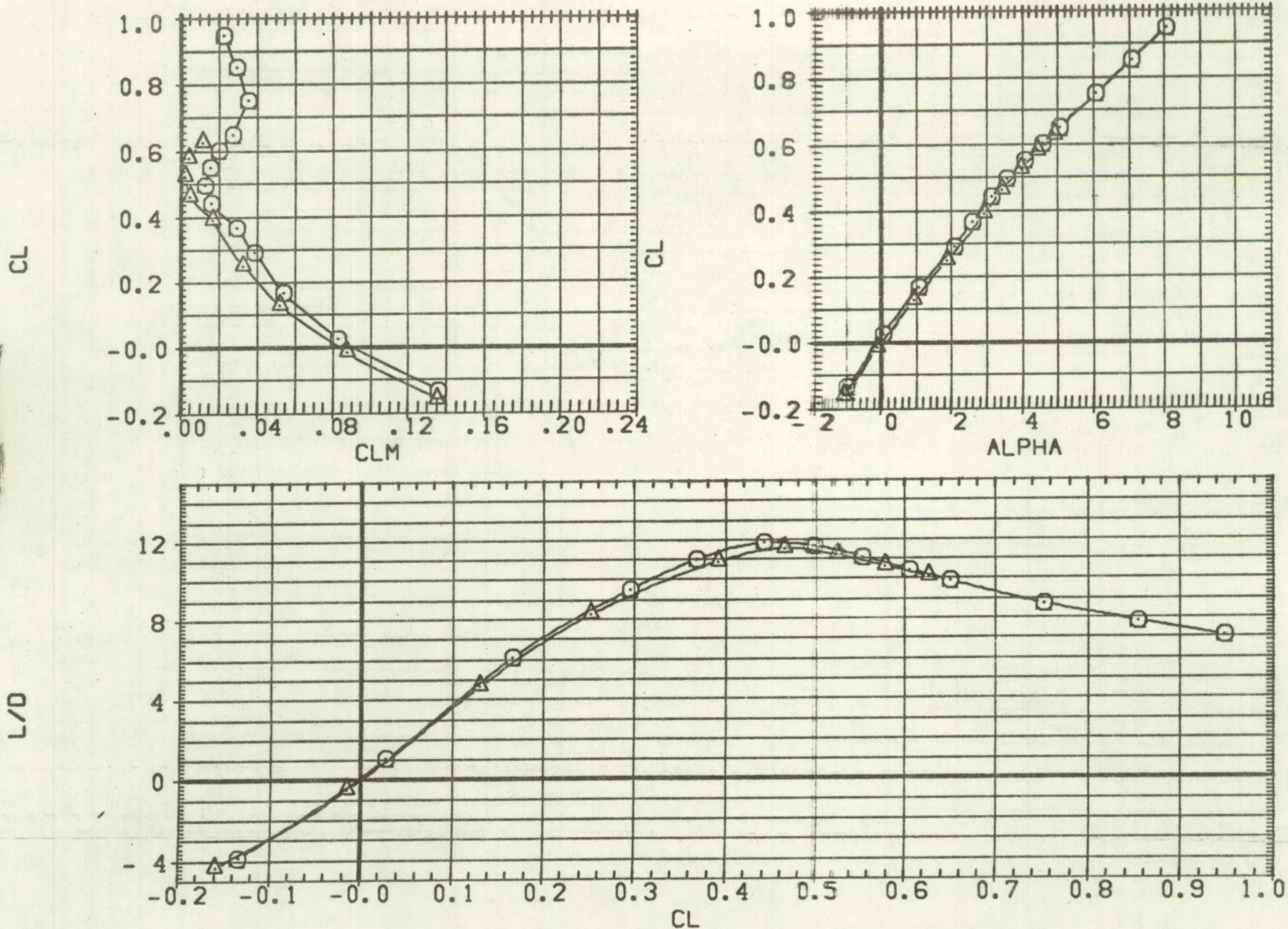



FIG 13 EFFECT OF BODY AREA RULE ON LONGITUDINAL AERODYNAMICS
 (C)MACH = 0.95

DATA SET SYMBOL CONFIGURATION DESCRIPTION
 (XAF007)  W1 B1 V1 H1
 (RAFO27)  W1 B3 V1 H1

BETA	HORIZT	SPLR-L	TRANS
0.000	-1.000	0.000	1.000
0.000	-1.000	0.000	1.000

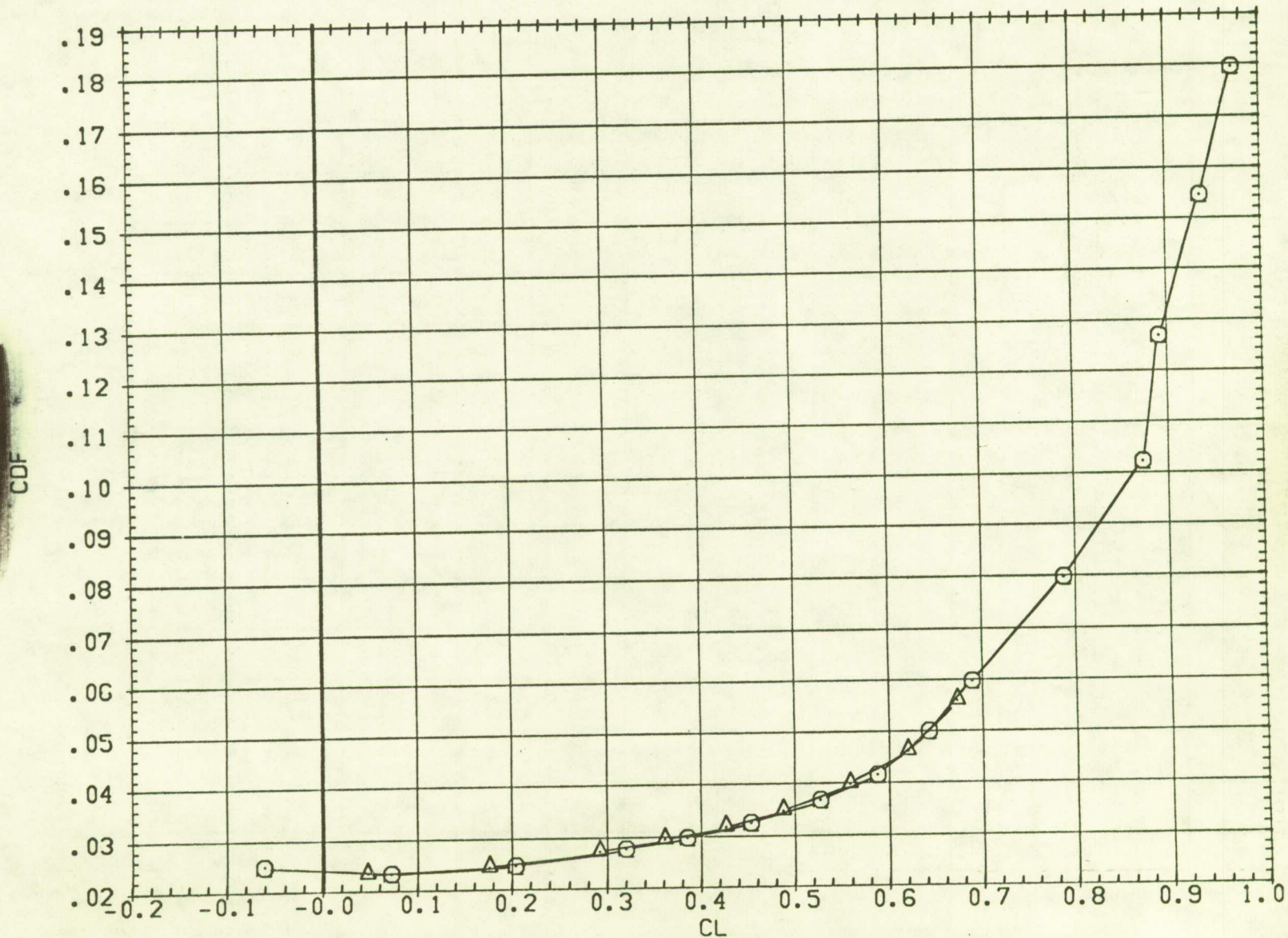



FIG 13 EFFECT OF BODY AREA RULE ON LONGITUDINAL AERODYNAMICS

(A)MACH = 0.90

DATA SET SYMBOL CONFIGURATION DESCRIPTION
 (XAF007)  W1 B1 V1 H1
 (RAF027)  W1 B3 V1 H1

BETA	HORIZT	SPLR-L	TRANS
0.000	-1.000	0.000	1.000
0.000	-1.000	0.000	1.000

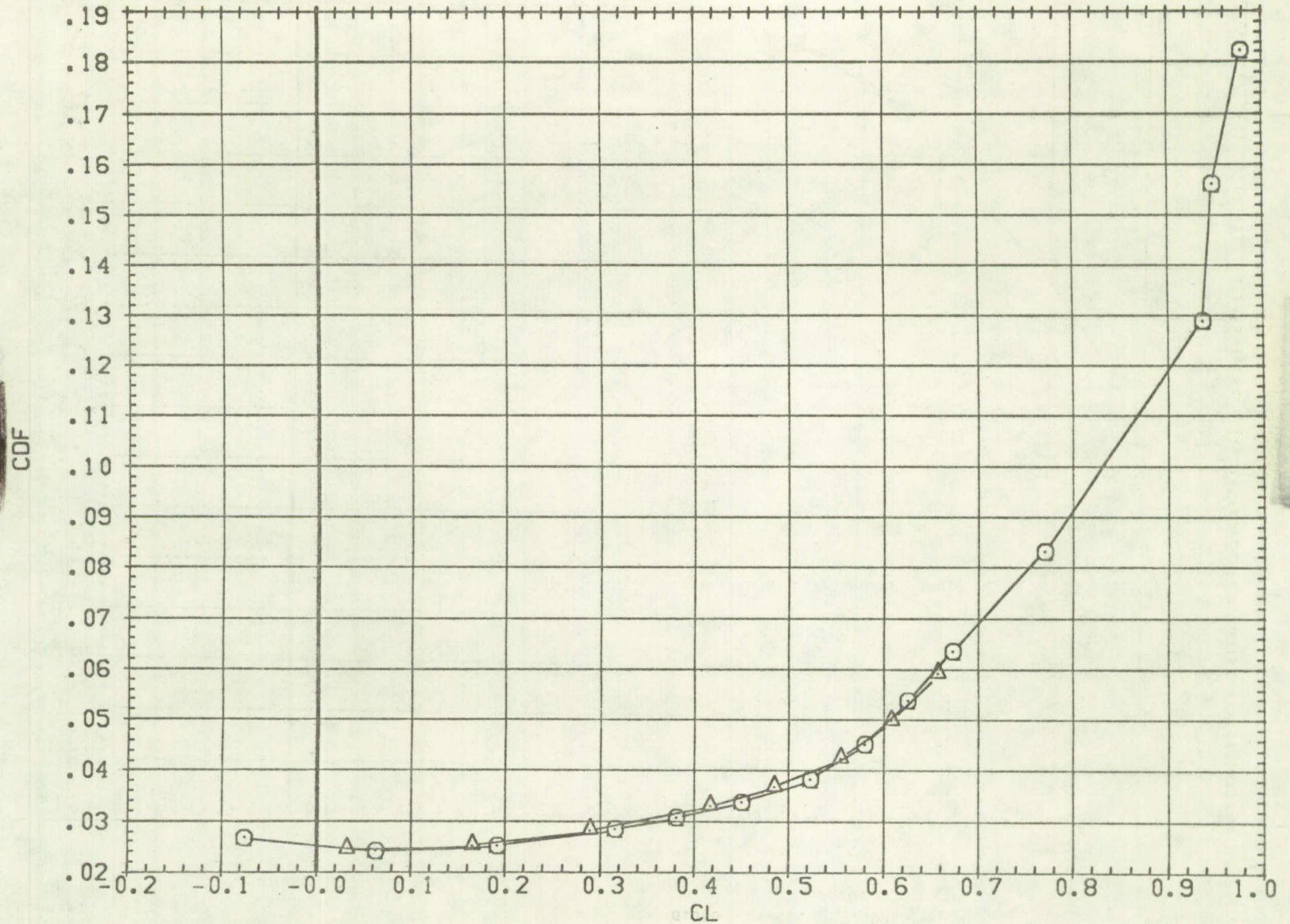



FIG 13 EFFECT OF BODY AREA RULE ON LONGITUDINAL AERODYNAMICS

(B)MACH = 0.92

DATA SET SYMBOL CONFIGURATION DESCRIPTION
 (XAF007)  W1 B1 V1 H1
 (RAFD27)  W1 B3 V1 H1

BETA	HORIZT	SPLR-L	TRANS
0.000	-1.000	0.000	1.000
0.000	-1.000	0.000	1.000

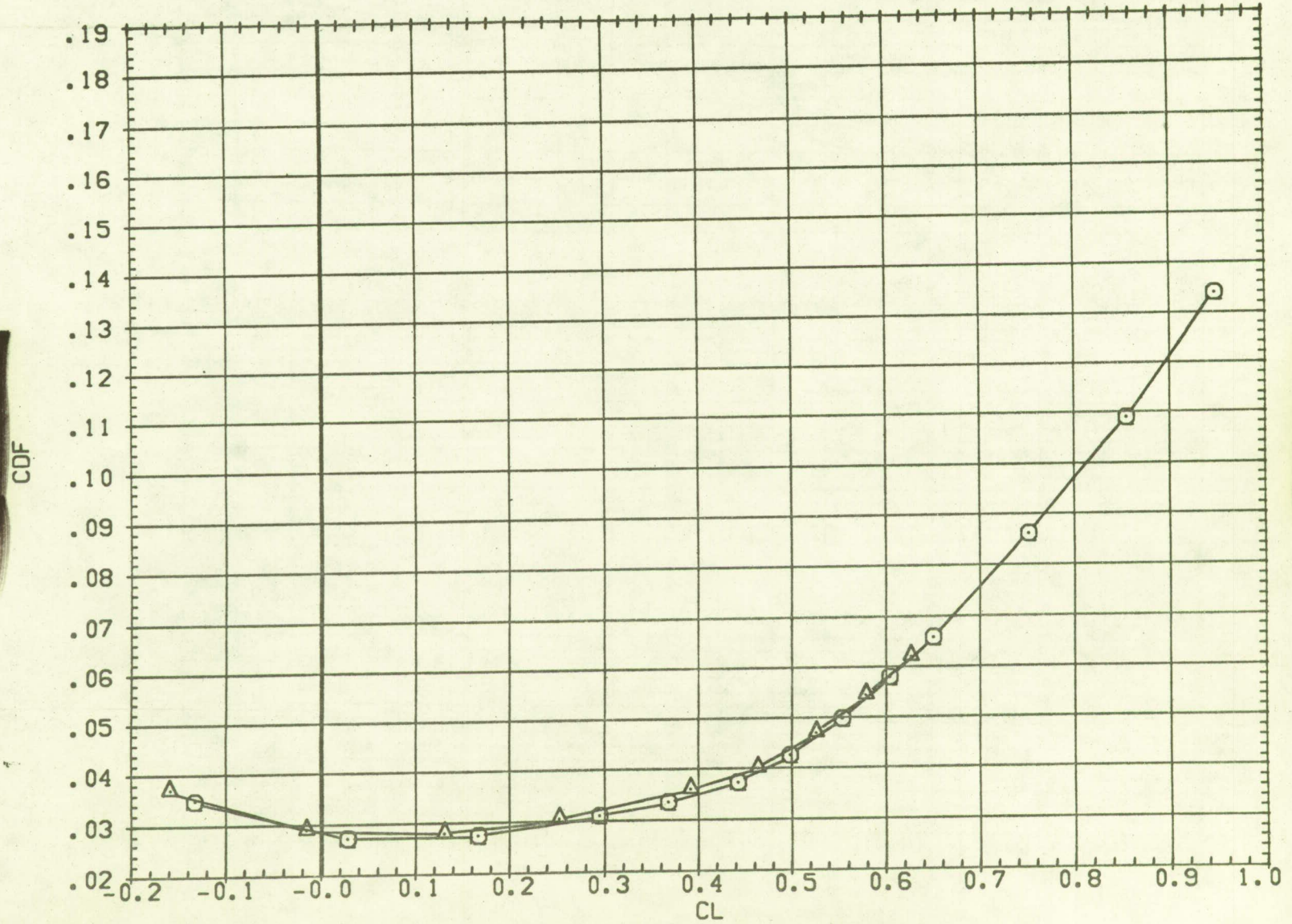

FIG 13 EFFECT OF BODY AREA RULE ON LONGITUDINAL AERODYNAMICS

(C)MACH = 0.95

DATA SET SYMBOL CONFIGURATION DESCRIPTION

(TAF003) ○ W1 B1 V1 H1

(TAF005) △ W1 B1 V1 H1

(TAF007) □ W1 B1 V1 H1

(TAF010) ◇ W1 B1 V1 H1

BETA	HORIZT	SPLR-L	TRANS
0.000	0.000	0.000	0.000
0.000	0.000	0.000	1.000
0.000	-1.000	0.000	1.000
0.000	-1.000	0.000	2.000

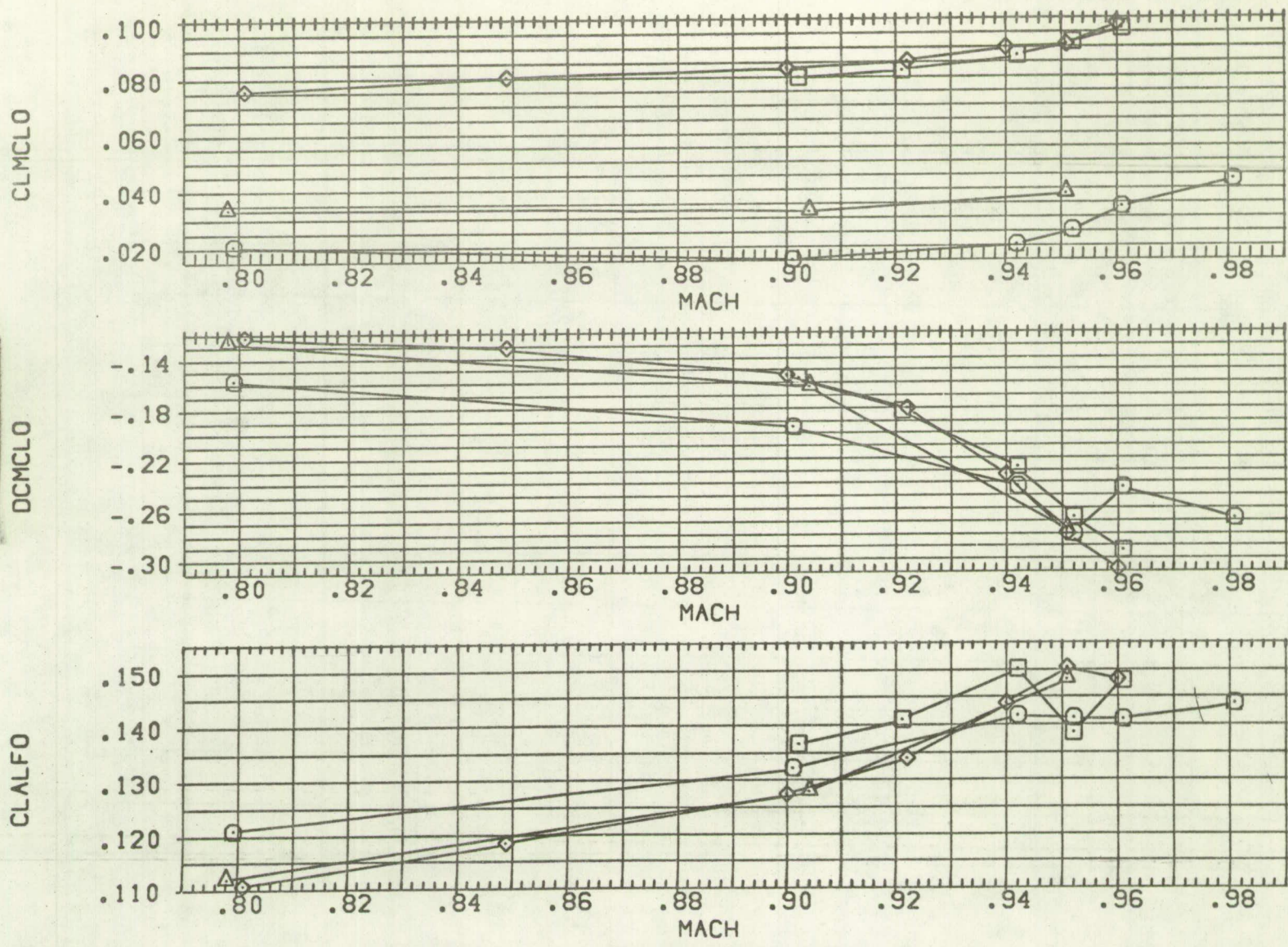

FIG 14A EFFECT OF MACH NUMBER ON LONGITUDINAL AERODYNAMICS

DATA SET SYMBOL	CONFIGURATION DESCRIPTION
(TAF003)	W1 B1 V1 H1
(TAF005)	W1 B1 V1 H1
(TAF007)	W1 B1 V1 H1
(TAF010)	W1 B1 V1 H1

BETA	HORIZT	SPLR-L	TRANS
0.000	0.000	0.000	0.000
0.000	0.000	0.000	1.000
0.000	-1.000	0.000	1.000
0.000	-1.000	0.000	2.000

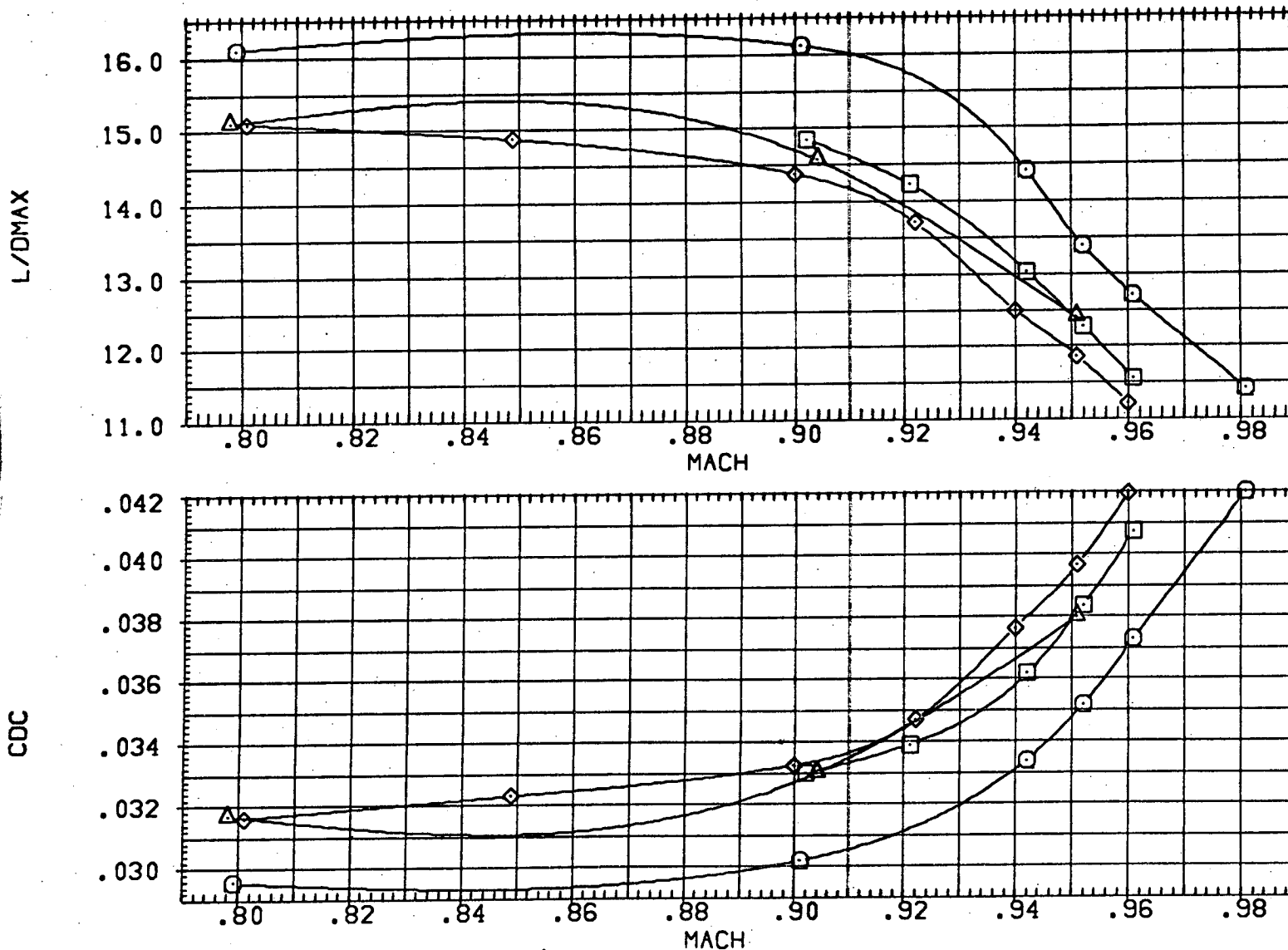



FIG 14A EFFECT OF MACH NUMBER ON LONGITUDINAL AERODYNAMICS

DATA SET SYMBOL CONFIGURATION DESCRIPTION
 (TAF013)  W1 B1 V1 H1 K1 N1 K2 N2 ZF1
 (TAF011)  W1 B1 V1 H1 K1 N1 K2 N2 ZF1

BETA	HORIZT	SPLR-L	TRANS
0.000	-1.000	0.000	1.000
0.000	-1.000	0.000	2.000

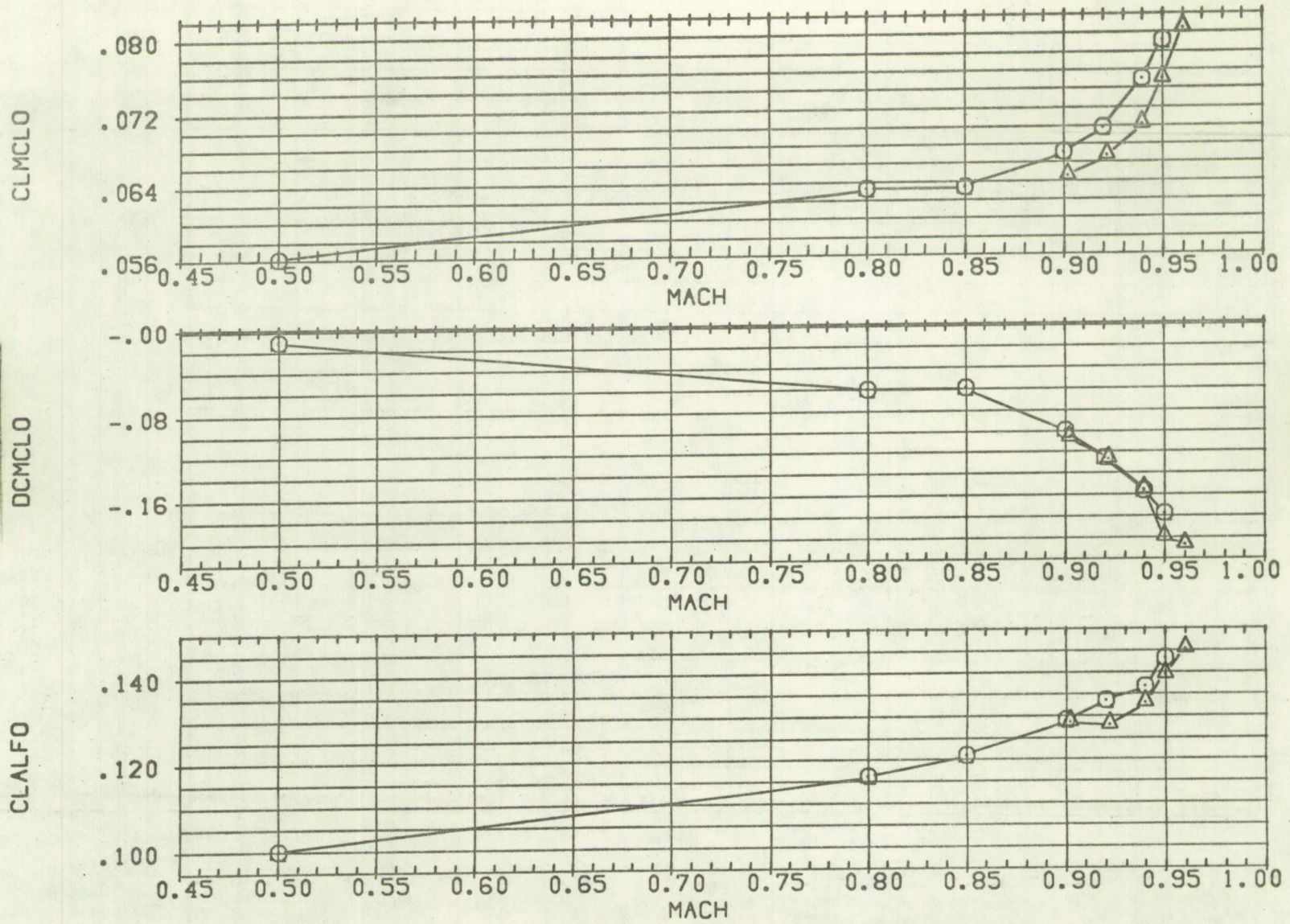

FIG 14B EFFECT OF MACH NUMBER ON LONGITUDINAL AERODYNAMICS

DATA SET SYMBOL CONFIGURATION DESCRIPTION
 (TAFD13) ○ W1 B1 V1 H1 K1 N1 K2 N2 ZF1
 (TAFD11) △ W1 B1 V1 H1 K1 N1 K2 N2 ZF1

BETA HORIZT SPLR-L TRANS
 0.000 -1.000 0.000 1.000
 0.000 -1.000 0.000 2.000

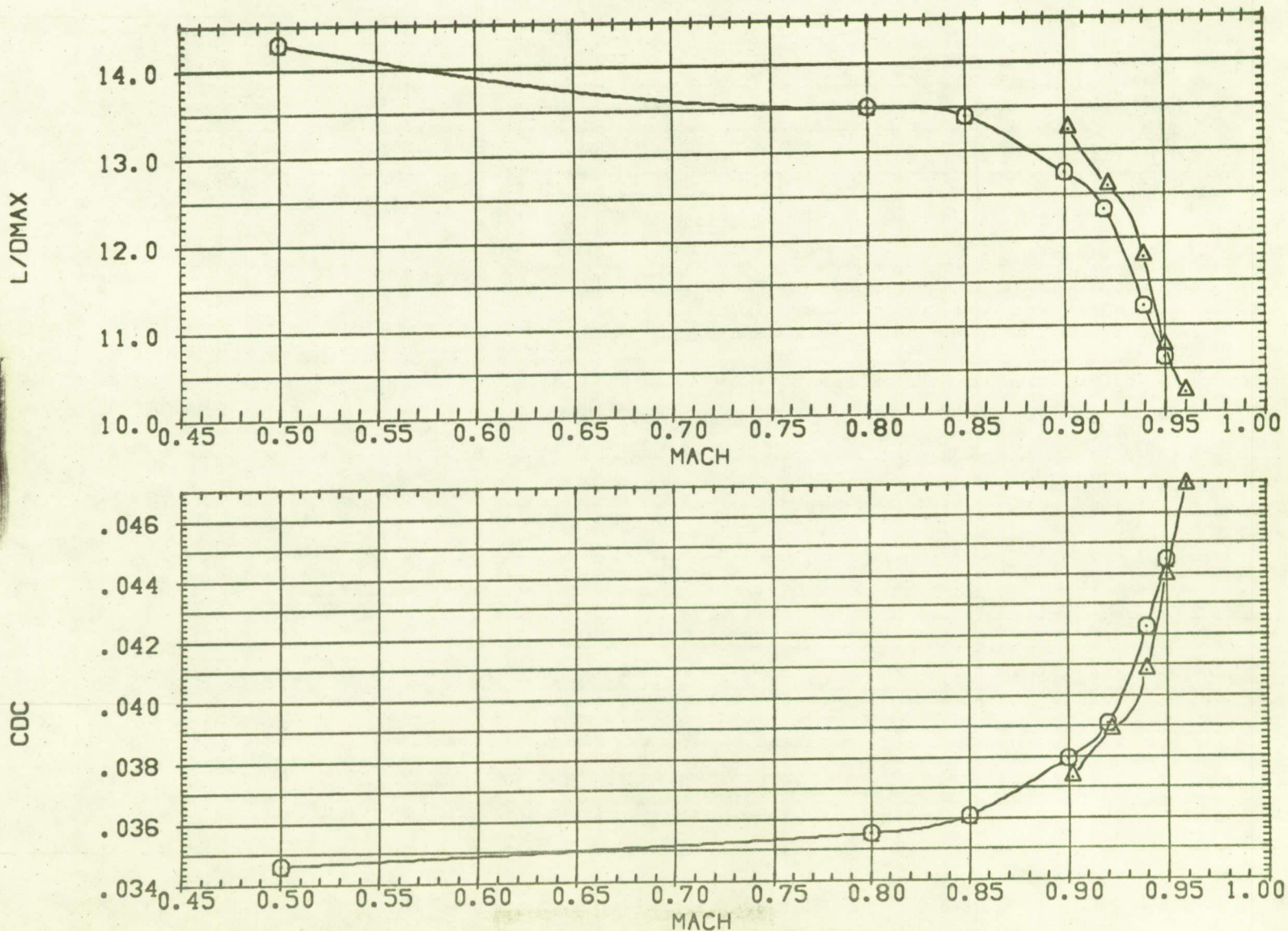

FIG 14B EFFECT OF MACH NUMBER ON LONGITUDINAL AERODYNAMICS

DATA SET SYMBOL	CONFIGURATION DESCRIPTION
(TAF013)	○ W1 B1 V1 H1 K1 N1 K2 N2 ZF1
(TAF020)	△ W1 B1 V1 K1 N1 K2 N2 ZF1
(TAF021)	◇ W1 B1 K1 N1 K2 N2 ZF1

BETA	HORIZT	SPLR-L	TRANS
0.000	-1.000	0.000	1.000
0.000		0.000	1.000
0.000		0.000	1.000

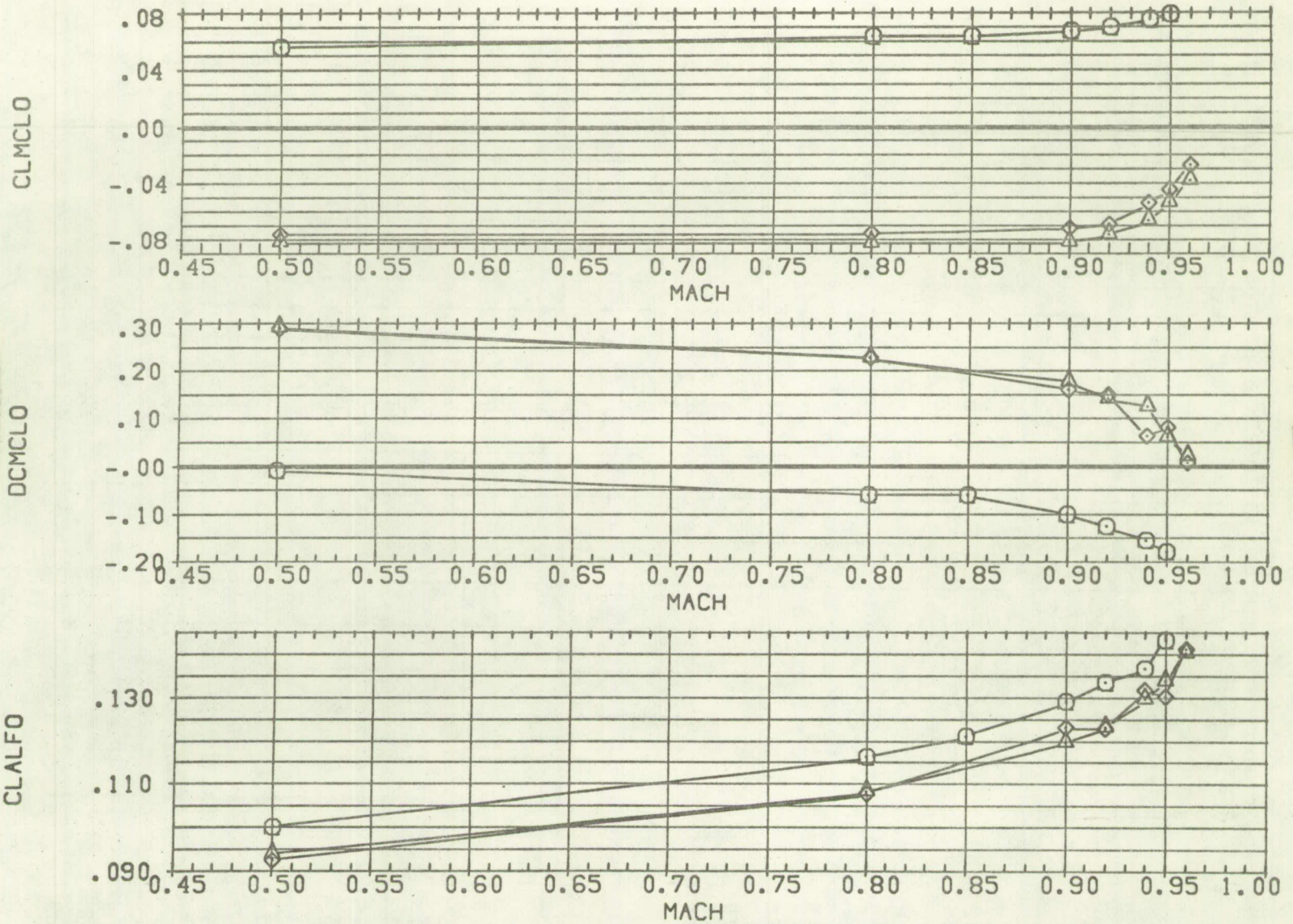

FIG 15A CONTRIBUTION OF MODEL COMPONENTS TO LONG. AERO. AS A FUNCTION OF MACH

DATA SET SYMBOL	CONFIGURATION DESCRIPTION
(TAF013)	W1 B1 V1 H1 K1 N1 K2 N2 ZF1
(TAF020)	W1 B1 V1 K1 N1 K2 N2 ZF1
(TAF021)	W1 B1 K1 N1 K2 N2 ZF1

BETA	HORIZT	SPLR-L	TRANS
0.000	-1.000	0.000	1.000
0.000		0.000	1.000
0.000		0.000	1.000

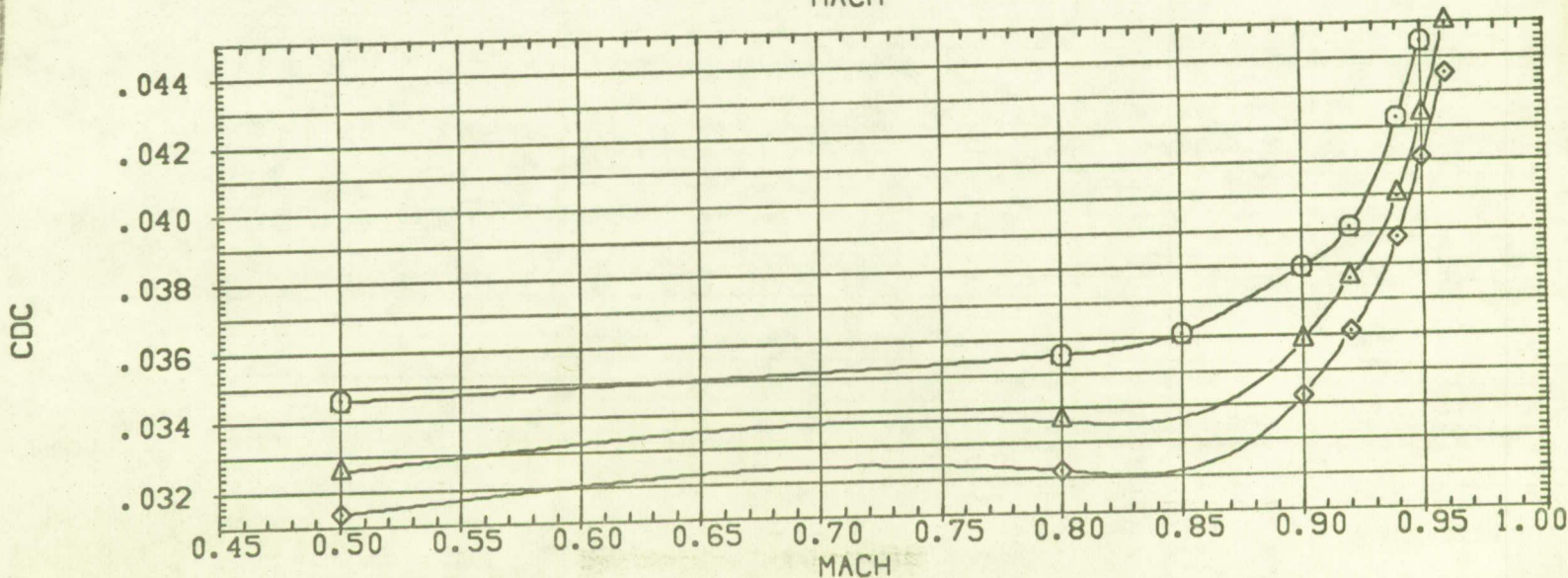
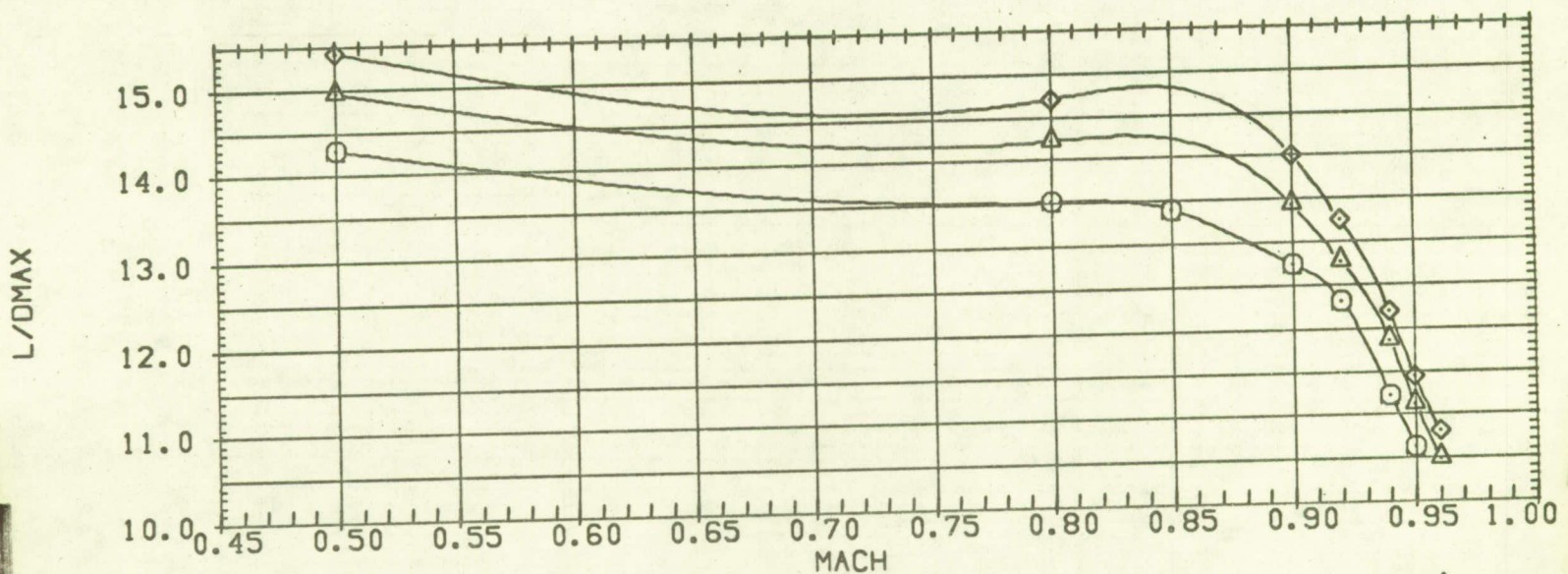

FIG 15A CONTRIBUTION OF MODEL COMPONENTS TO LONG. AERO. AS A FUNCTION OF MACH

DATA SET SYMBOL	CONFIGURATION DESCRIPTION
(TAF021)	W1 B1 K1 N1 K2 N2 ZF1
(TAF022)	W1 B1 K1 N1 K2 N2
(TAF023)	W1 B1 K1 N1
(TAF024)	W1 B1

BETA	HORIZT	SPLR-L	TRANS
0.000	0.000	1.000	
0.000	0.000	1.000	
0.000	0.000	1.000	
0.000	0.000	1.000	

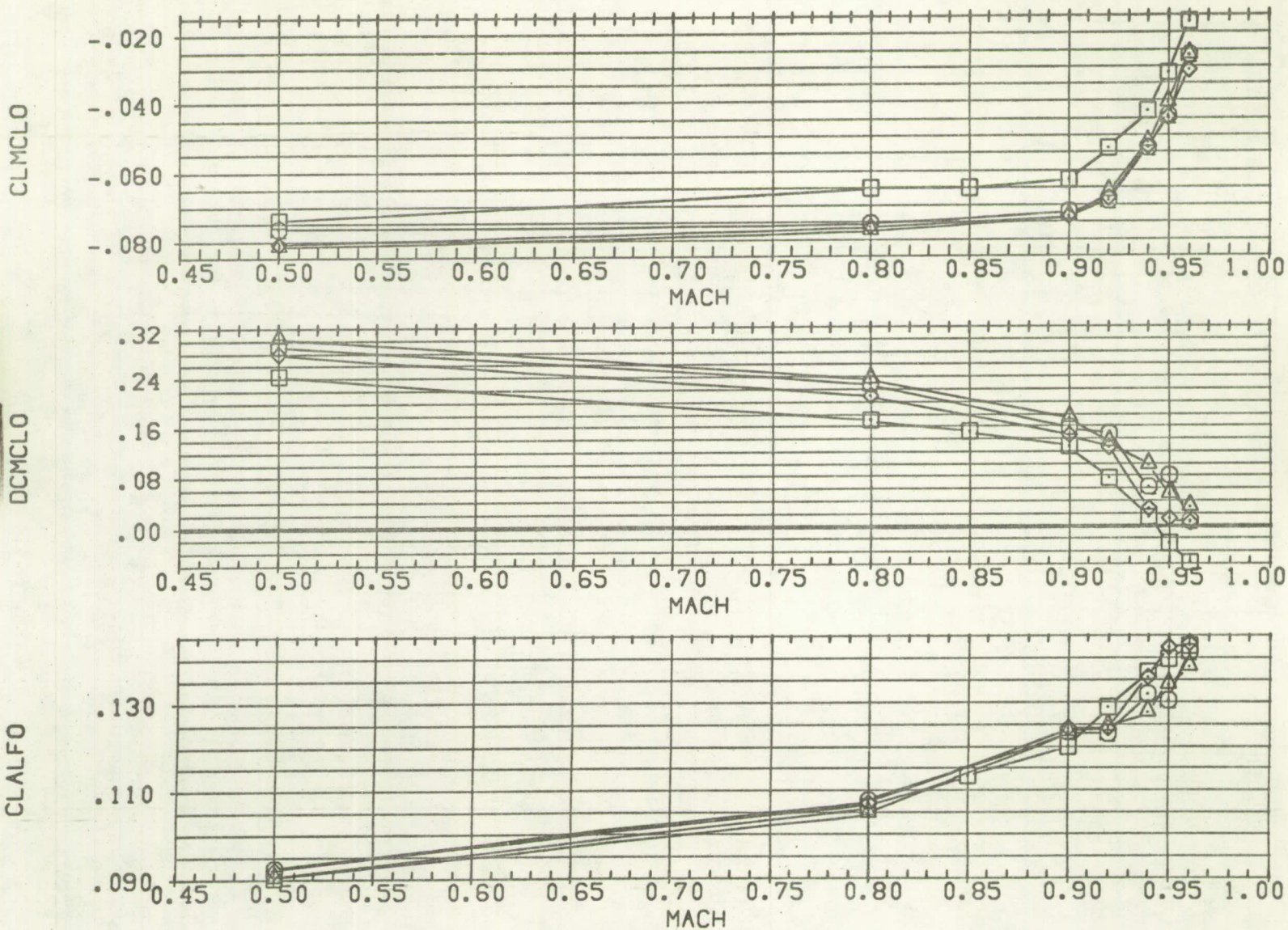

FIG 15B CONTRIBUTION OF MODEL COMPONENTS TO LONG. AERO. AS A FUNCTION OF MACH

DATA SET SYMBOL	CONFIGURATION DESCRIPTION
(TAF021)	W1 B1 K1 N1 K2 N2 ZF1
(TAF022)	W1 B1 K1 N1 K2 N2
(TAF023)	W1 B1 K1 N1
(TAF024)	W1 B1

BETA	HORIZT	SPLR-L	TRANS
0.000		0.000	1.000
0.000		0.000	1.000
0.000		0.000	1.000
0.000		0.000	1.000

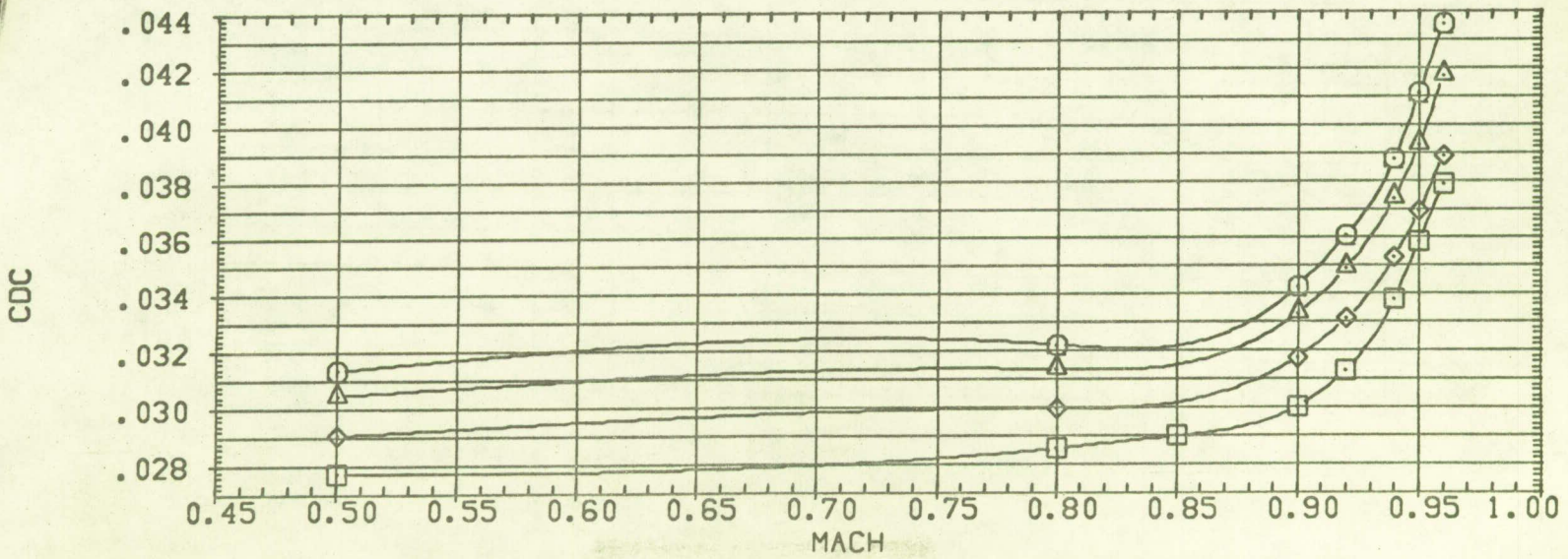
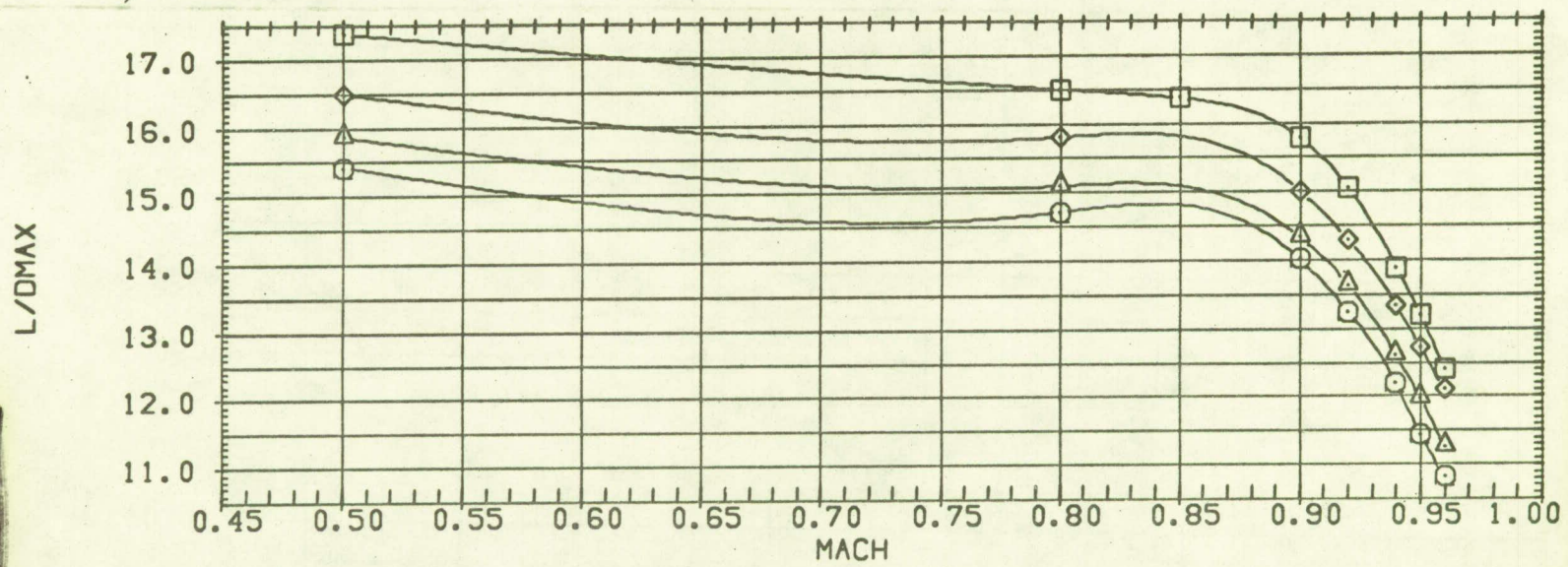

FIG 15B CONTRIBUTION OF MODEL COMPONENTS TO LONG. AERO. AS A FUNCTION OF MACH

SYMBOL	ALPHA	BETA	PARAMETRIC VALUES		
○	0.000	0.000	HORIZT	-	3.000
△	4.000	0.000	TRANS		1.000
◇	8.000	4.000	RN/L		4.000

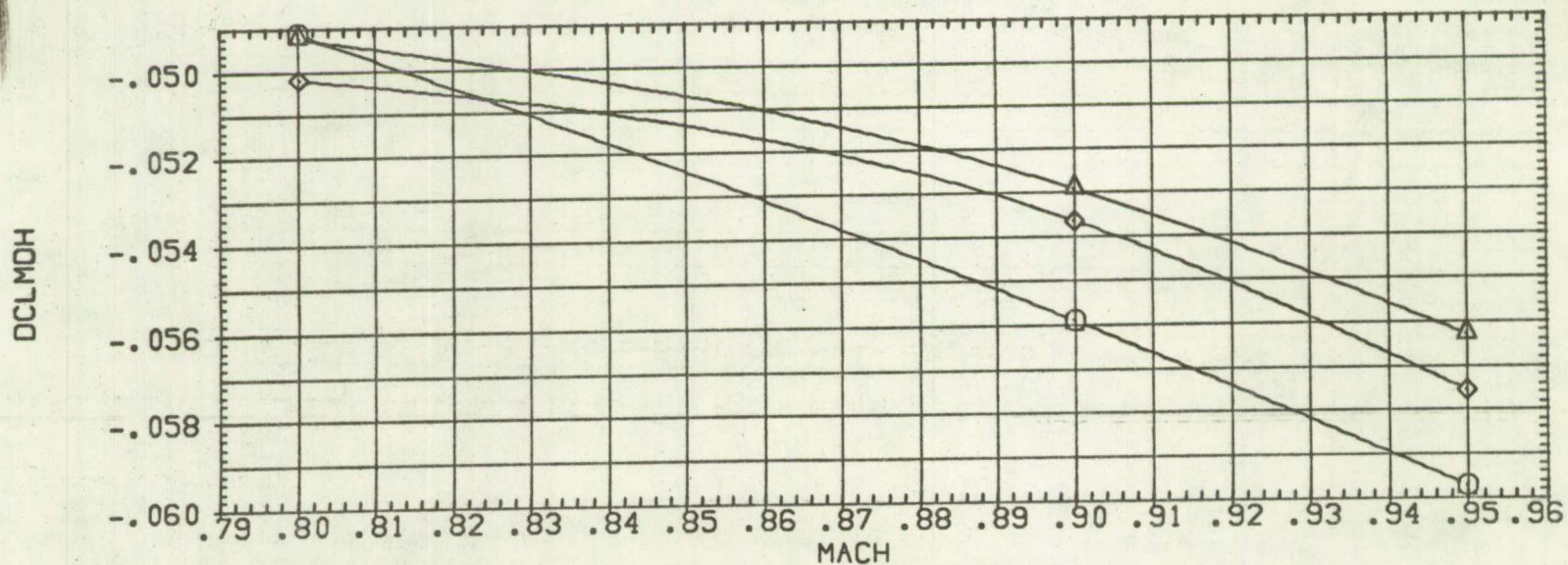
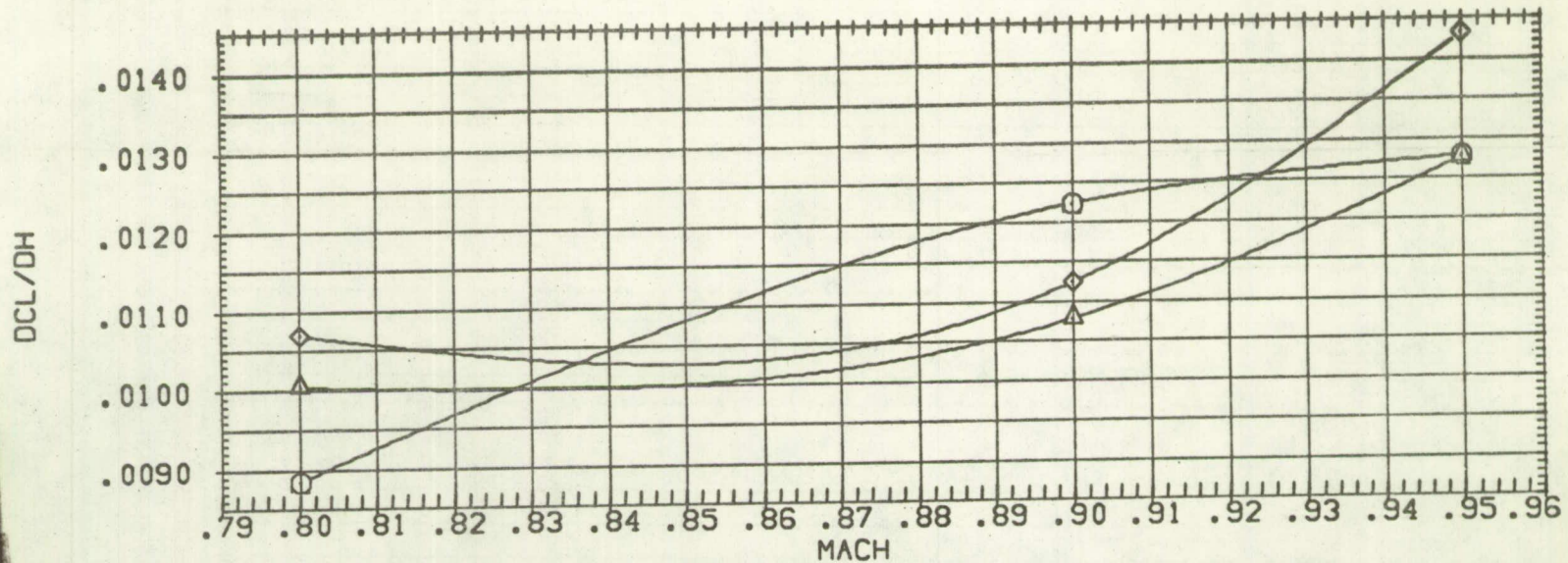

FIG 16 EFFECT OF MACH NUMBER ON LONGITUDINAL CONTROL

SYMBOL	ALPHA	BETA	PARAMETRIC VALUES	
○	0.000	0.000	HORIZT	- 1.000
△	4.000	SPLR-L	- 10.000	TRANS 1.000
◇	8.000	RN/L	4.000	

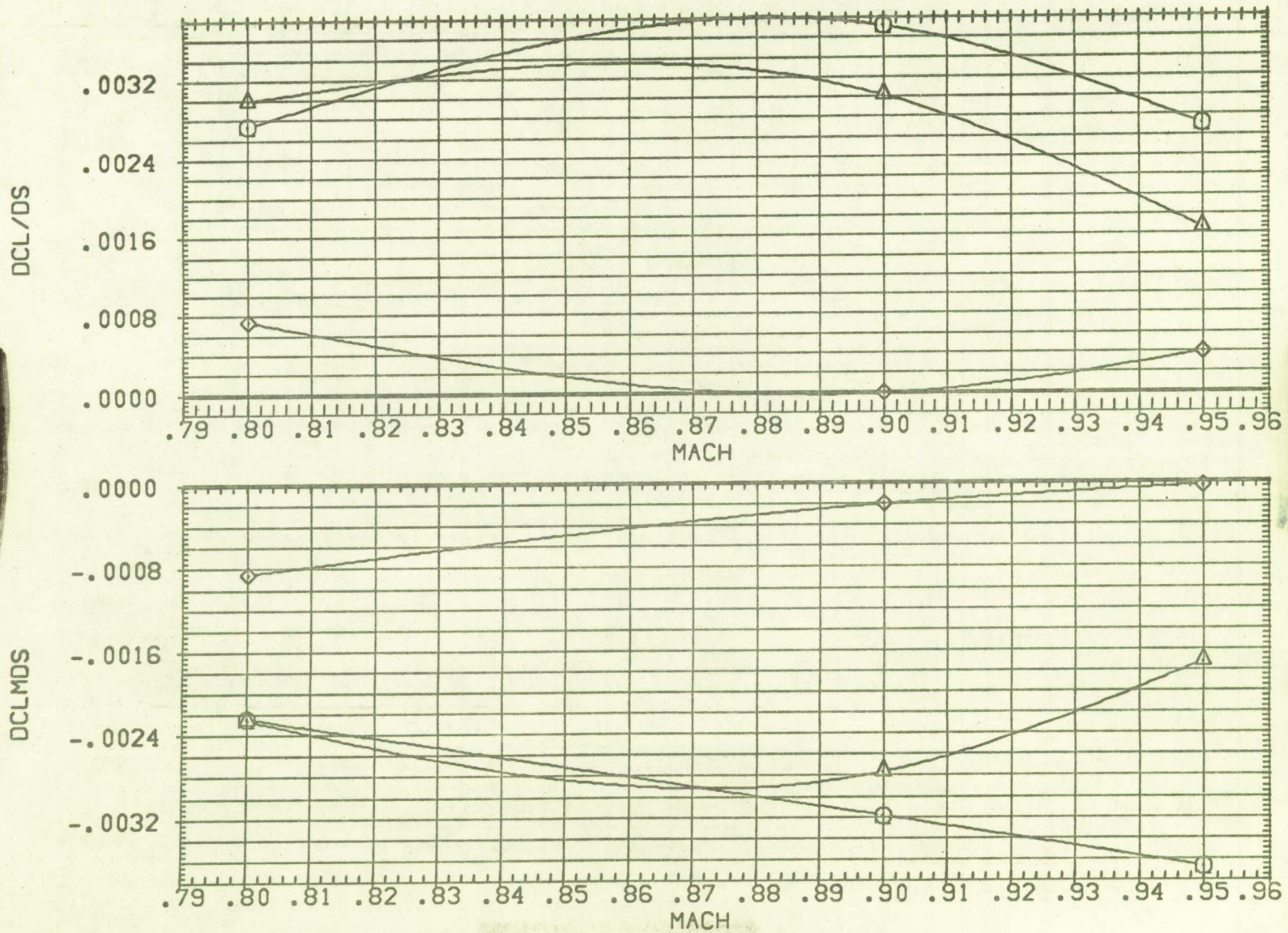

FIG 16 EFFECT OF MACH NUMBER ON LONGITUDINAL CONTROL

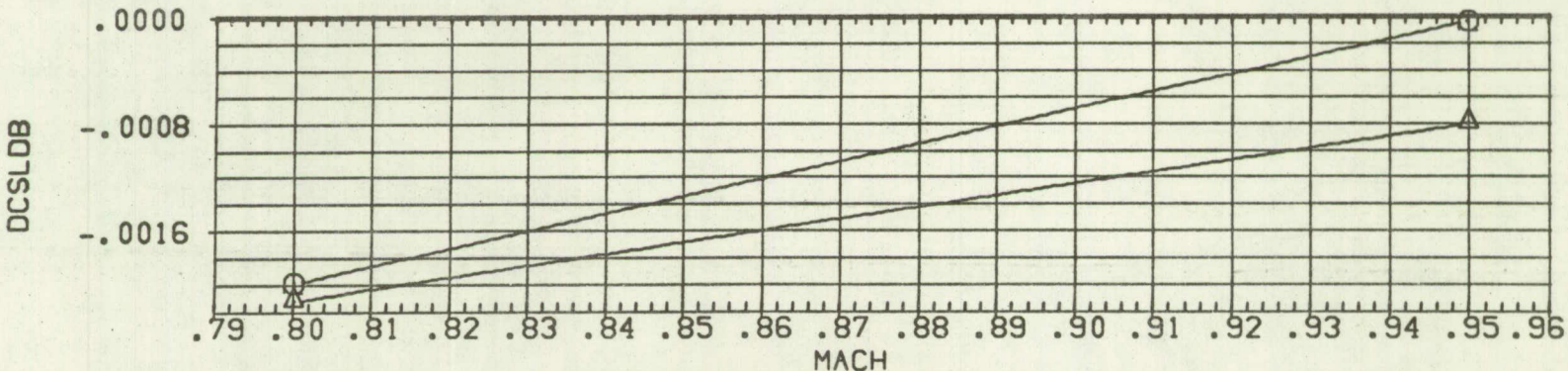
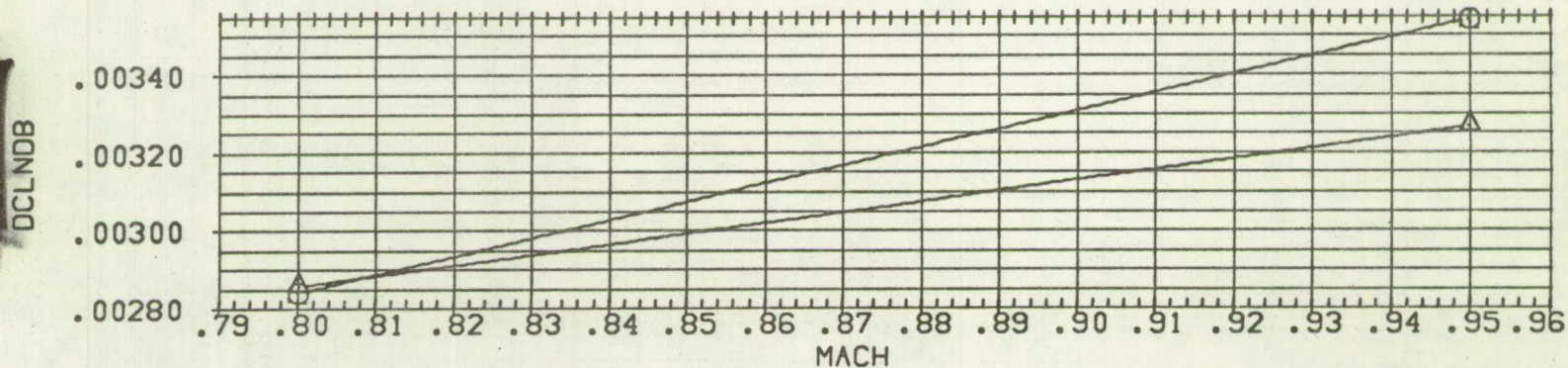
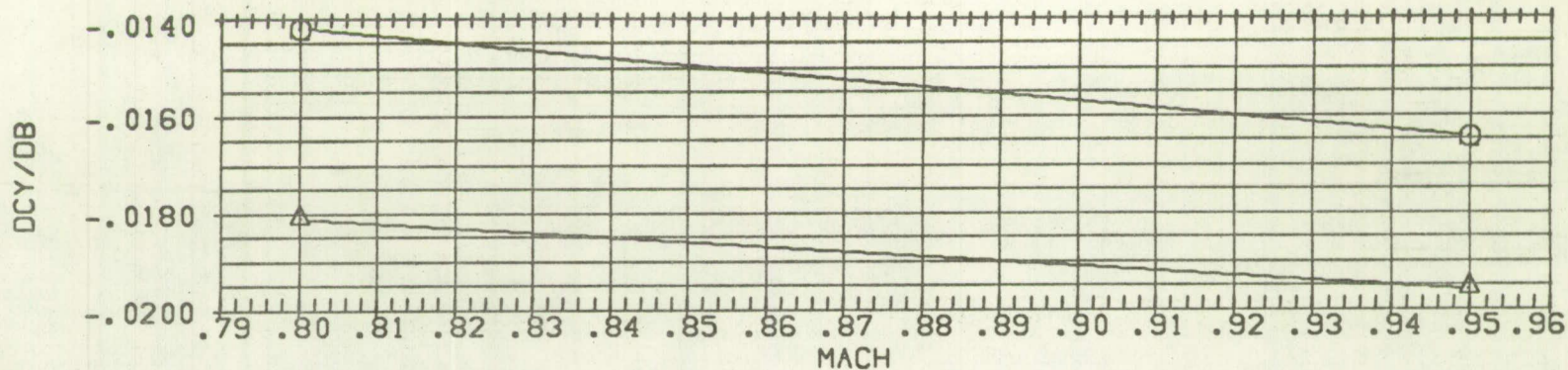

FIG 17 EFFECT OF MACH NUMBER ON LATERAL-DIRECTIONAL STABILITY
 (A) ALPHA = 0.00

SYMBOL	ALPHA	BETA	PARAMETRIC VALUES	
○	0.000		0.000	HORIZT - 1.000
		SPLR-L	- 10.000	TRANS 1.000
		RN/L	4.000	

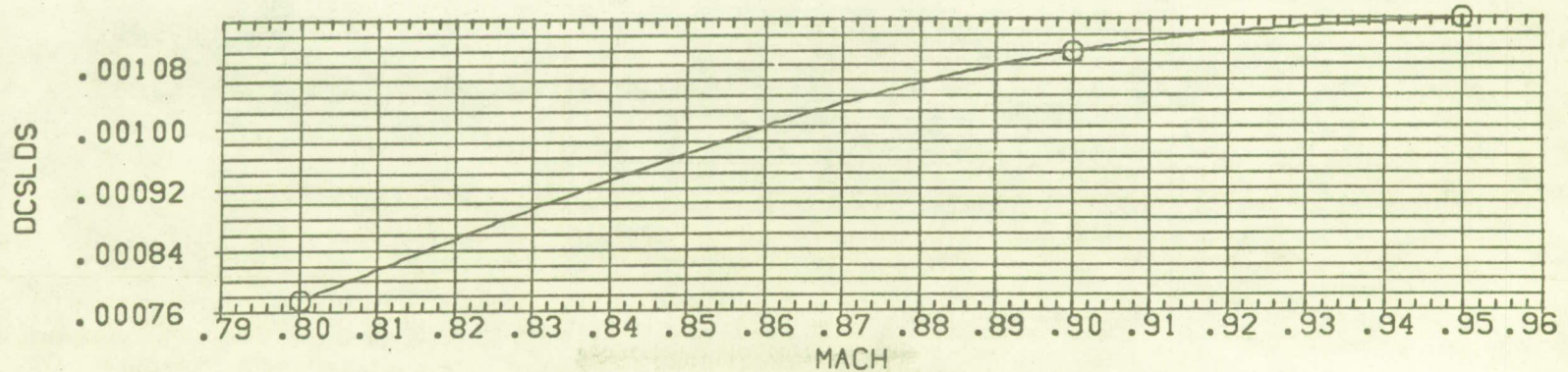
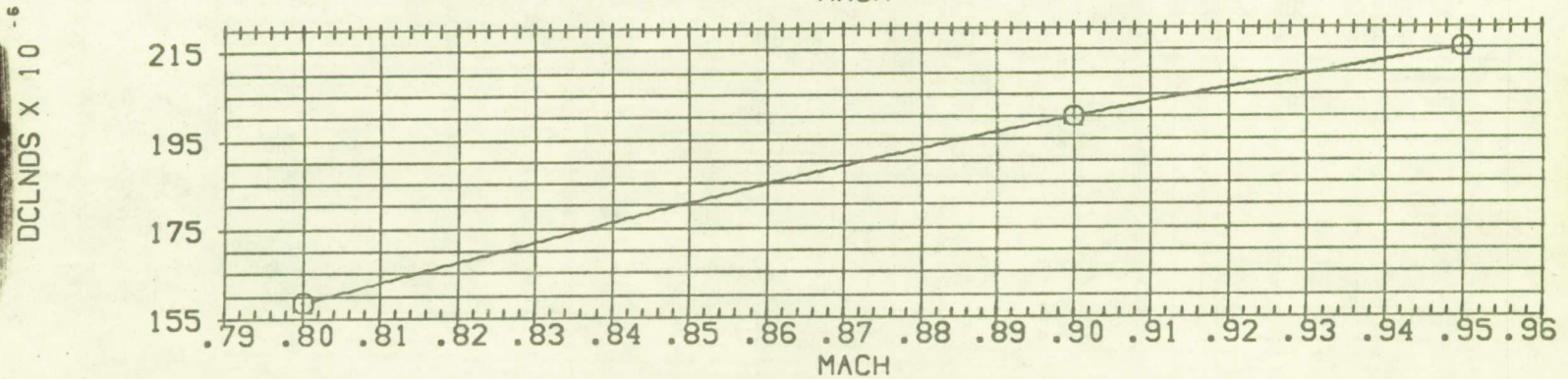
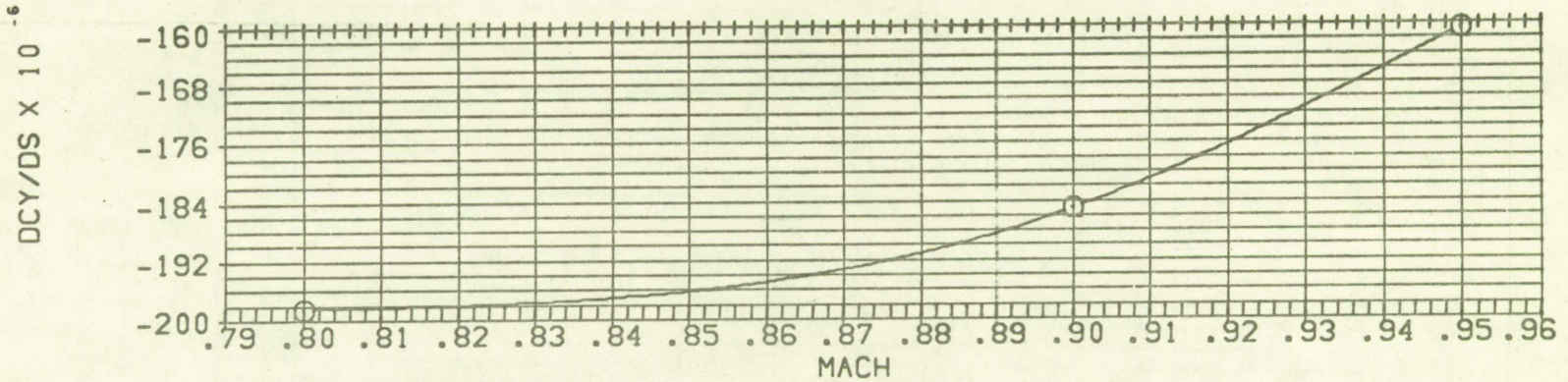

FIG 18 EFFECT OF MACH NUMBER ON LATERAL-DIRECTIONAL CONTROL

DATA SET SYMBOL	CONFIGURATION DESCRIPTION
(KAF013)	W1 B1 V1 H1 K1 N1 K2 N2 ZF1
(KAF018)	W1 B1 V1 H1 K1 N1 K2 N2 ZF1 S1
(KAF019)	W1 B1 V1 H1 K1 N1 K2 N2 ZF1 S1

BETA	HORIZT	SPLR-L	TRANS
0.000	-1.000	0.000	1.000
0.000	-1.000	-10.000	1.000
0.000	-1.000	-25.000	1.000

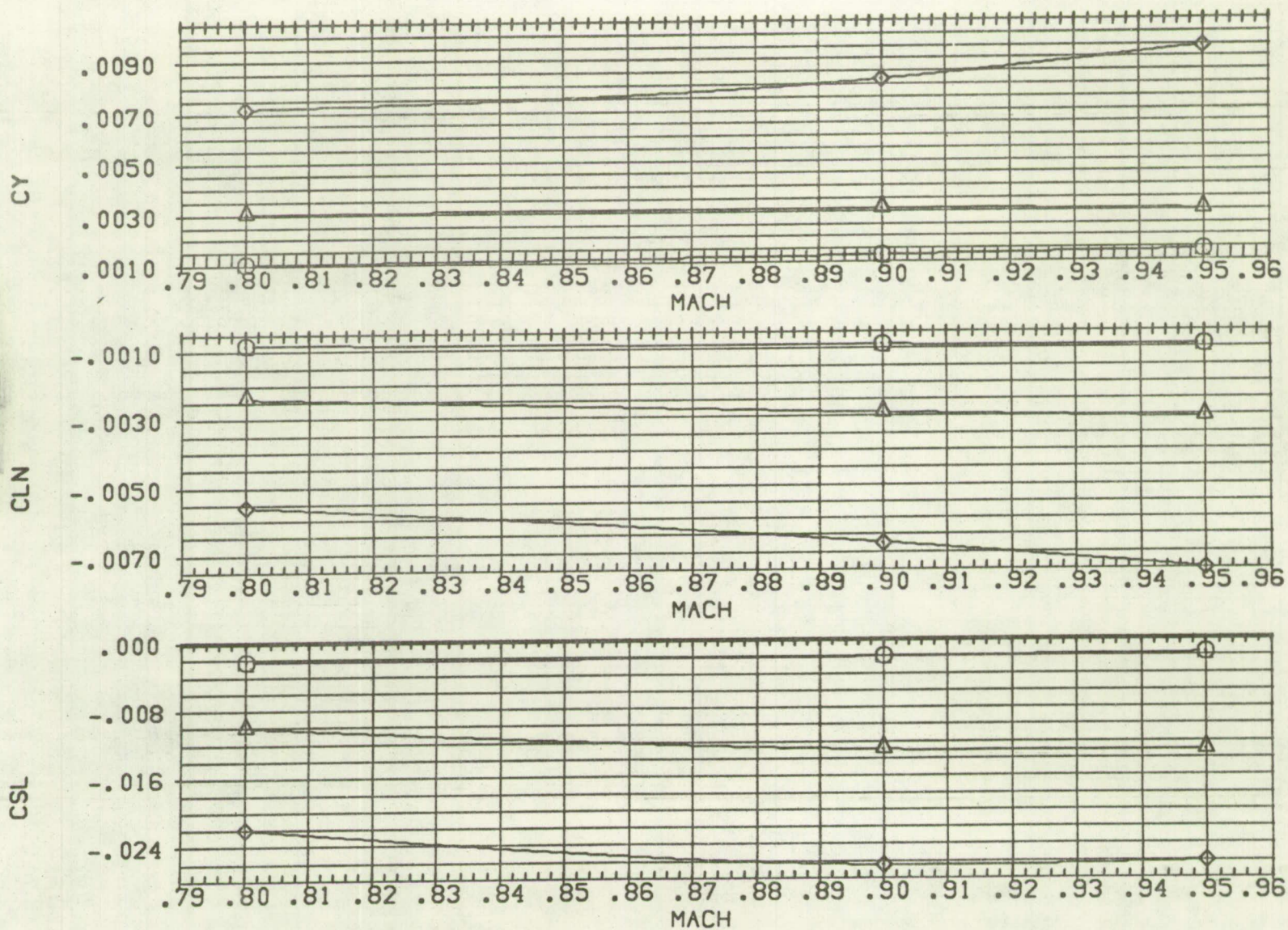

FIG 18 EFFECT OF MACH NUMBER ON LATERAL-DIRECTIONAL CONTROL
 (A) ALPHA = 0.00

DATA SET SYMBOL	CONFIGURATION DESCRIPTION
(KAF013)	W1 B1 V1 H1 K1 N1 K2 N2 ZF1
(KAF018)	W1 B1 V1 H1 K1 N1 K2 N2 ZF1 S1
(KAF019)	W1 B1 V1 H1 K1 N1 K2 N2 ZF1 S1

BETA	HORIZT	SPLR-L	TRANS
0.000	-1.000	0.000	1.000
0.000	-1.000	-10.000	1.000
0.000	-1.000	-25.000	1.000

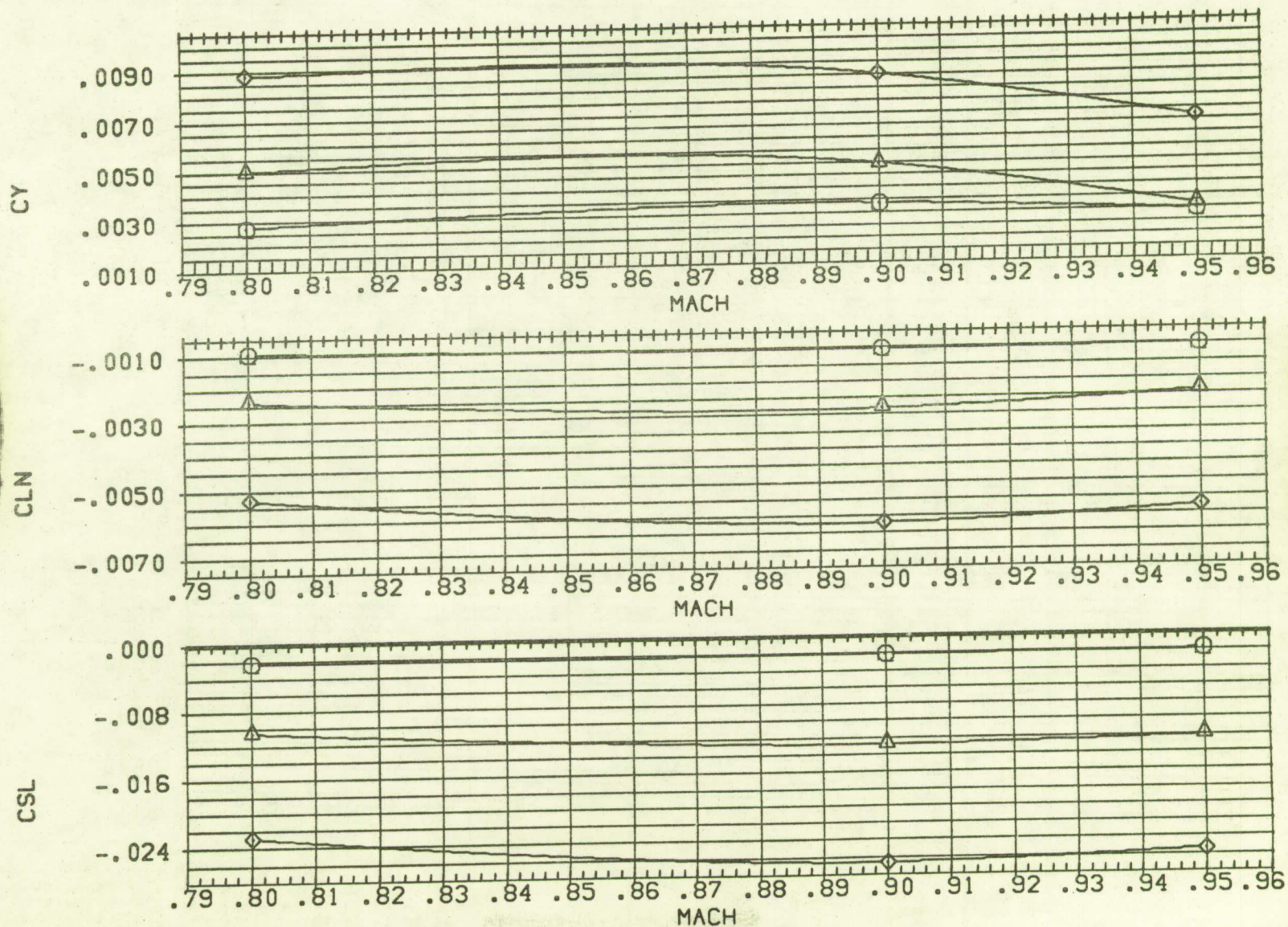

FIG 18 EFFECT OF MACH NUMBER ON LATERAL-DIRECTIONAL CONTROL

DATA SET SYMBOL	CONFIGURATION DESCRIPTION
(KAFD13)	W1 B1 V1 H1 K1 N1 K2 N2 ZF1
(KAFD18)	W1 B1 V1 H1 K1 N1 K2 N2 ZF1 S1
(KAFD19)	W1 B1 V1 H1 K1 N1 K2 N2 ZF1 S1

BETA	HORIZT	SPLR-L	TRANS
0.000	-1.000	0.000	1.000
0.000	-1.000	-10.000	1.000
0.000	-1.000	-25.000	1.000

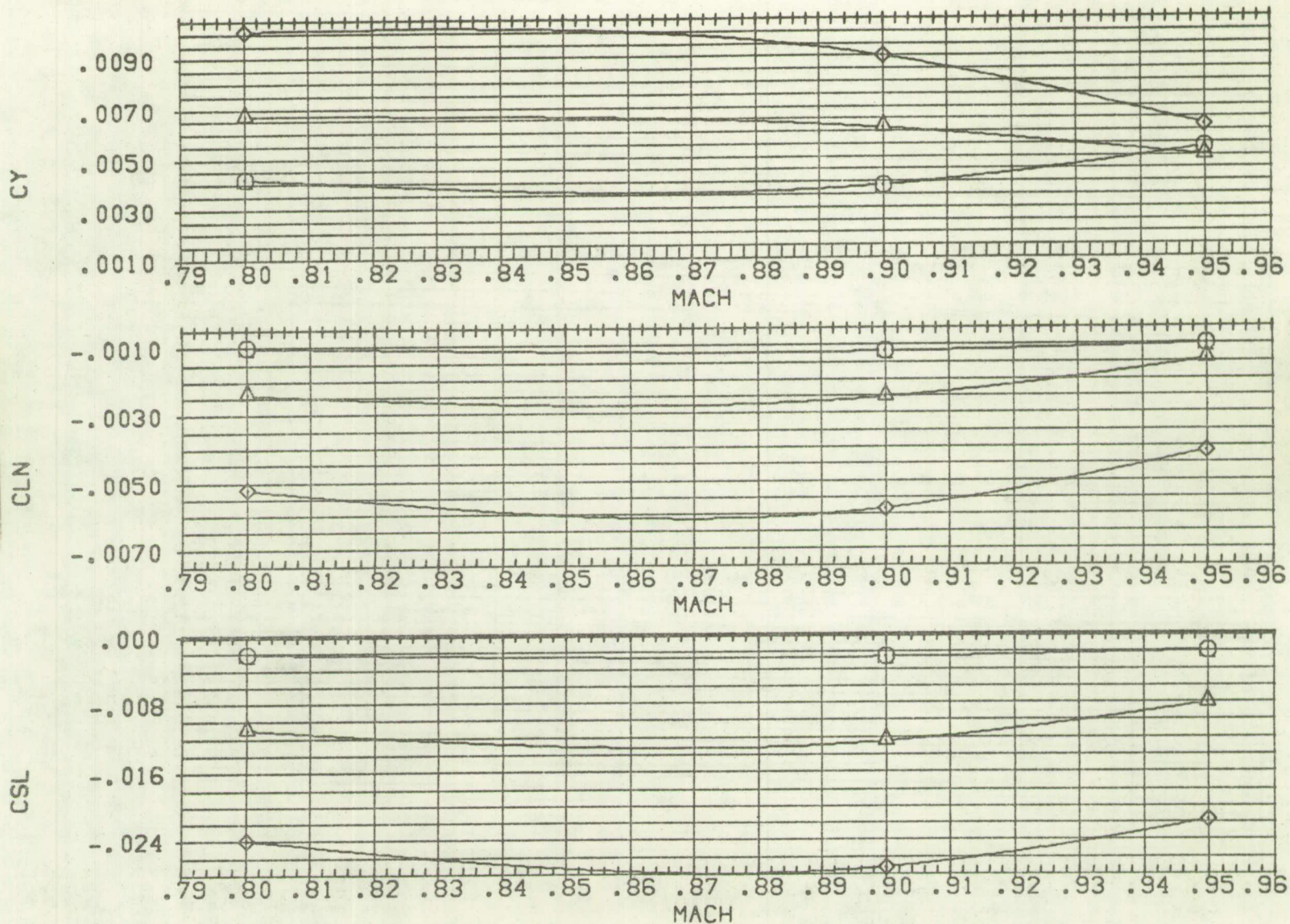

FIG 18 EFFECT OF MACH NUMBER ON LATERAL-DIRECTIONAL CONTROL
 (C) ALPHA = 4.00

DATA SET SYMBOL	CONFIGURATION DESCRIPTION
(KAFO13)	W1 B1 V1 H1 K1 N1 K2 N2 ZF1
(KAFO18)	W1 B1 V1 H1 K1 N1 K2 N2 ZF1 S1
(KAFO19)	W1 B1 V1 H1 K1 N1 K2 N2 ZF1 S1

BETA	HORIZT	SPLR-L	TRANS
0.000	-1.000	0.000	1.000
0.000	-1.000	-10.000	1.000
0.000	-1.000	-25.000	1.000

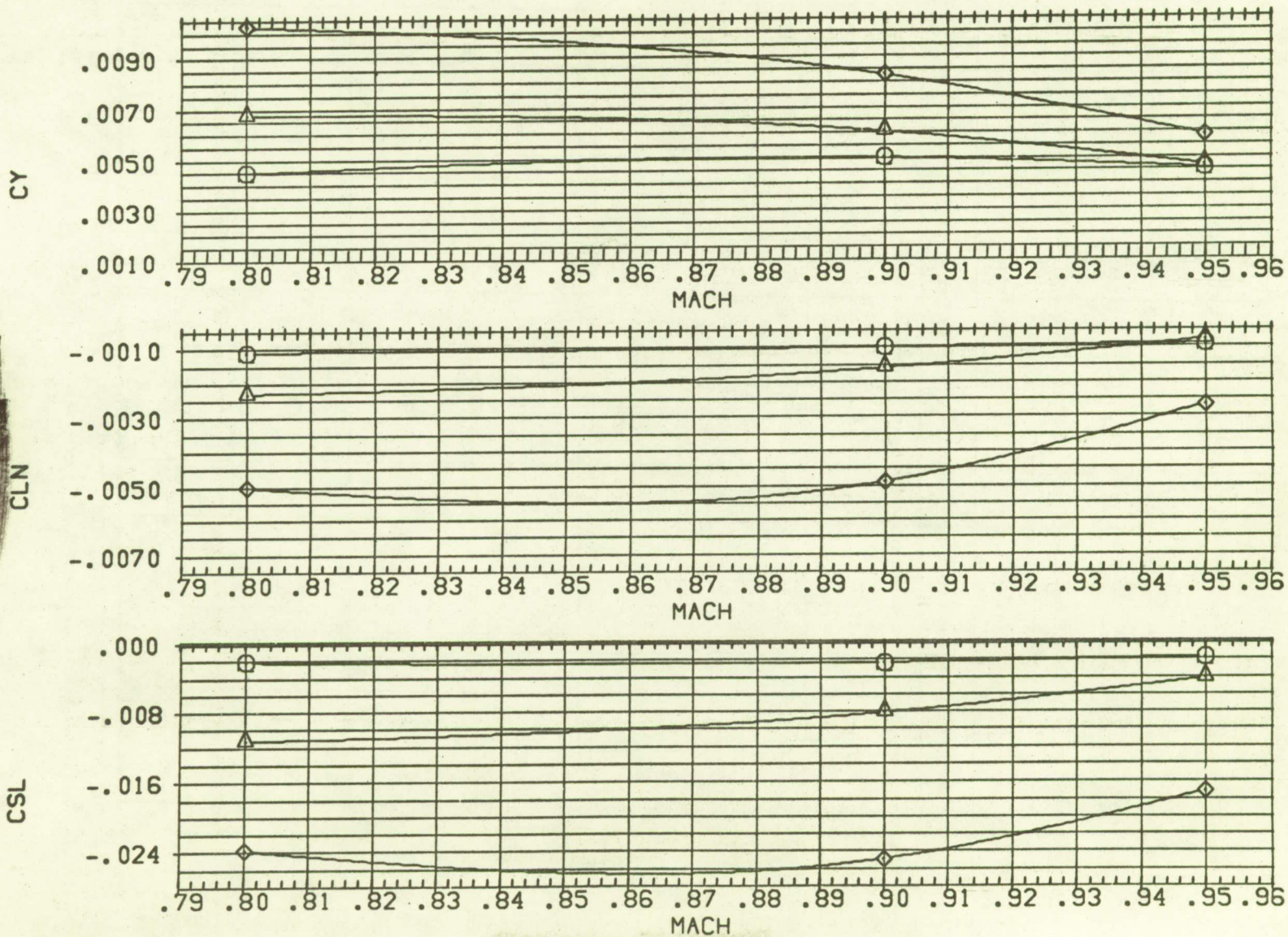

FIG 18 EFFECT OF MACH NUMBER ON LATERAL-DIRECTIONAL CONTROL
 (D) ALPHA = 5.00

SYMBOL ALPHA BL MACH
 ○ - 0.050 4.250 0.500

PARAMETRIC VALUES
 BETA 0.000 SPLR-L 0.000
 TRANS 1.000 RN/L 4.000

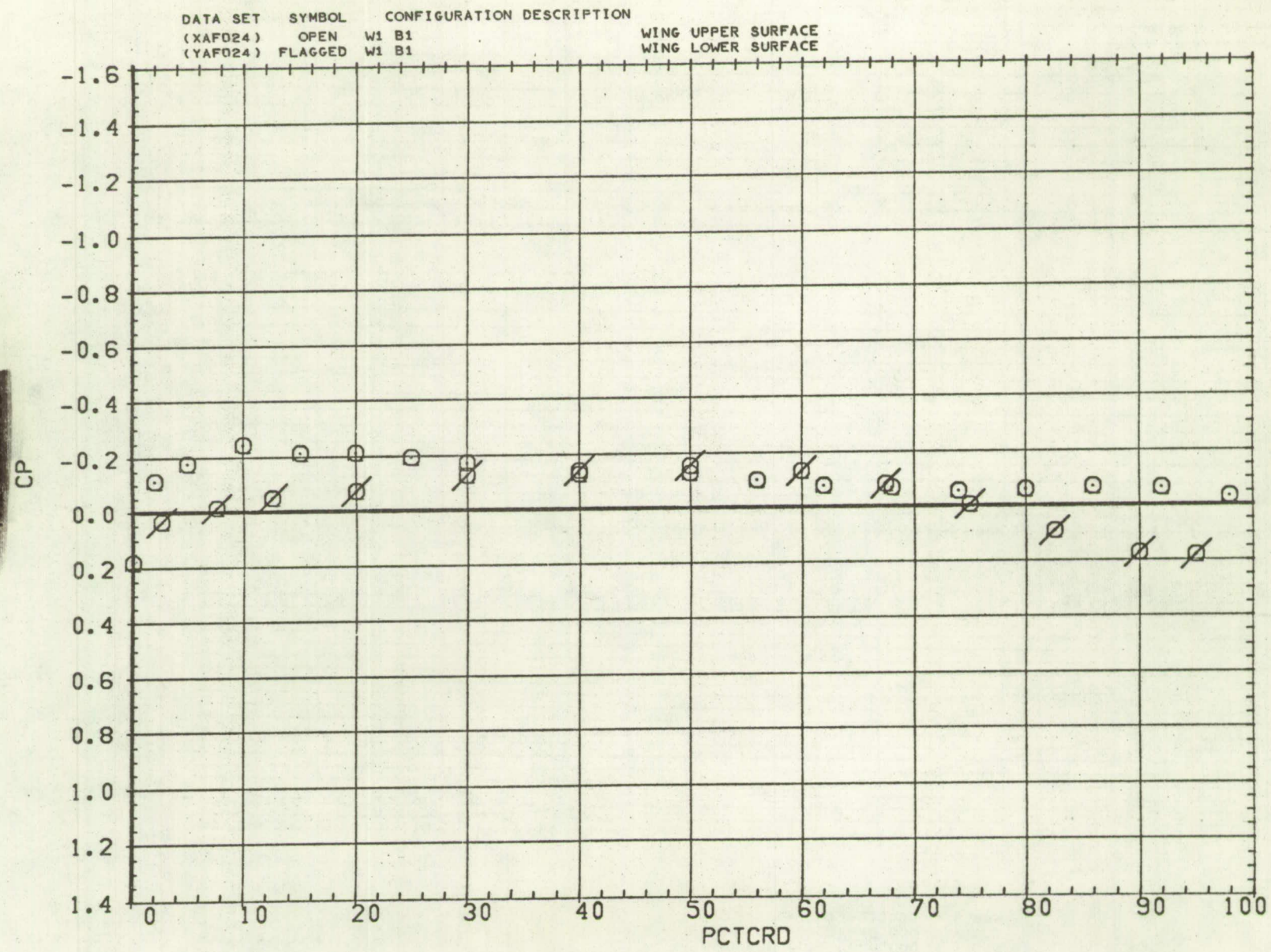

FIG. 19 WING PRESSURE DISTRIBUTION FOR BASIC WING-BODY

SYMBOL ALPHA BL MACH
 ○ 3.510 4.250 0.500

PARAMETRIC VALUES
 BETA 0.000 SPLR-L 0.000
 TRANS 1.000 RN/L 4.000

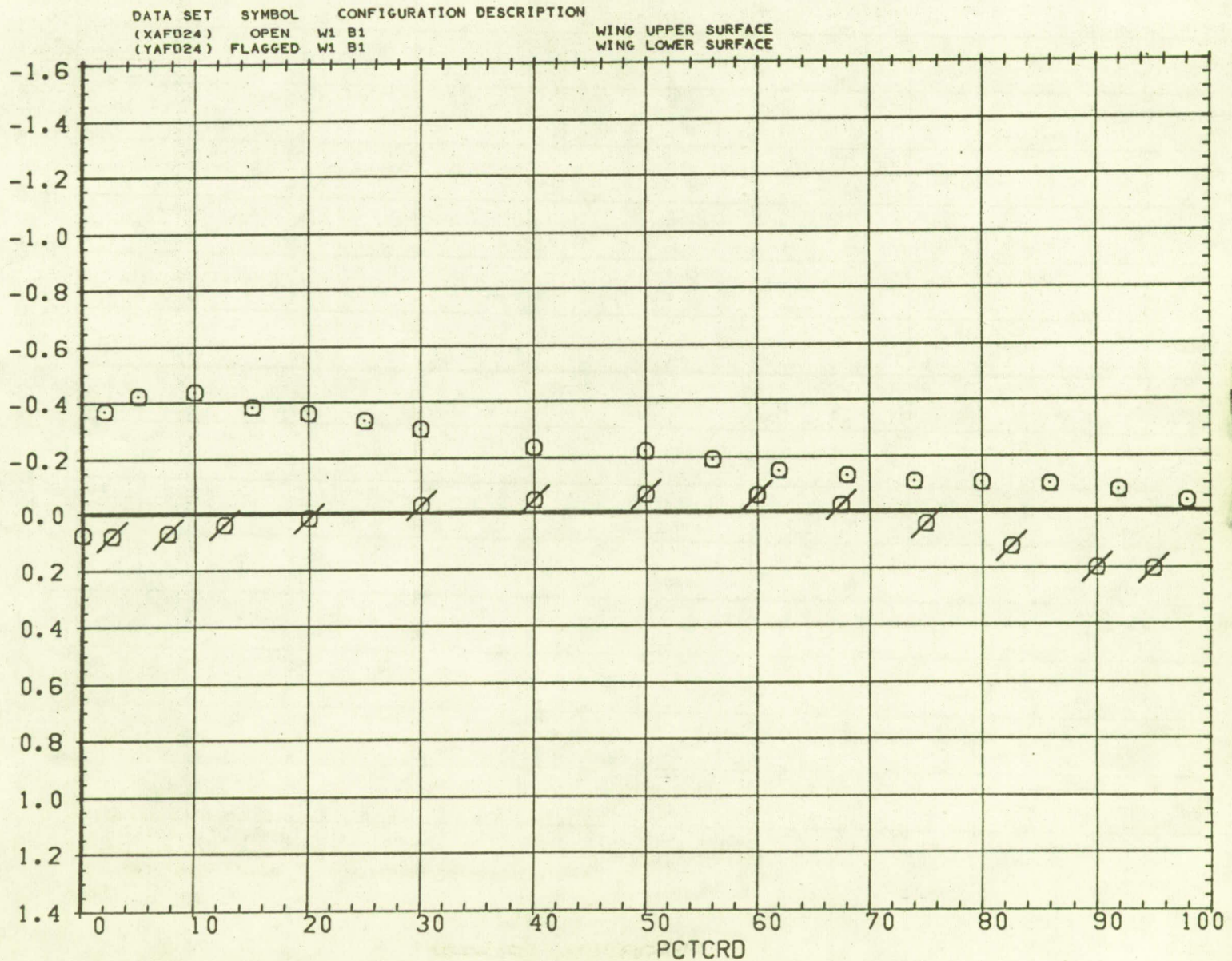

FIG. 19 WING PRESSURE DISTRIBUTION FOR BASIC WING-BODY

SYMBOL ALPHA BL MACH
 ○ 4.510 4.250 0.500

PARAMETRIC VALUES
 BETA 0.000 SPLR-L 0.000
 TRANS 1.000 RN/L 4.000

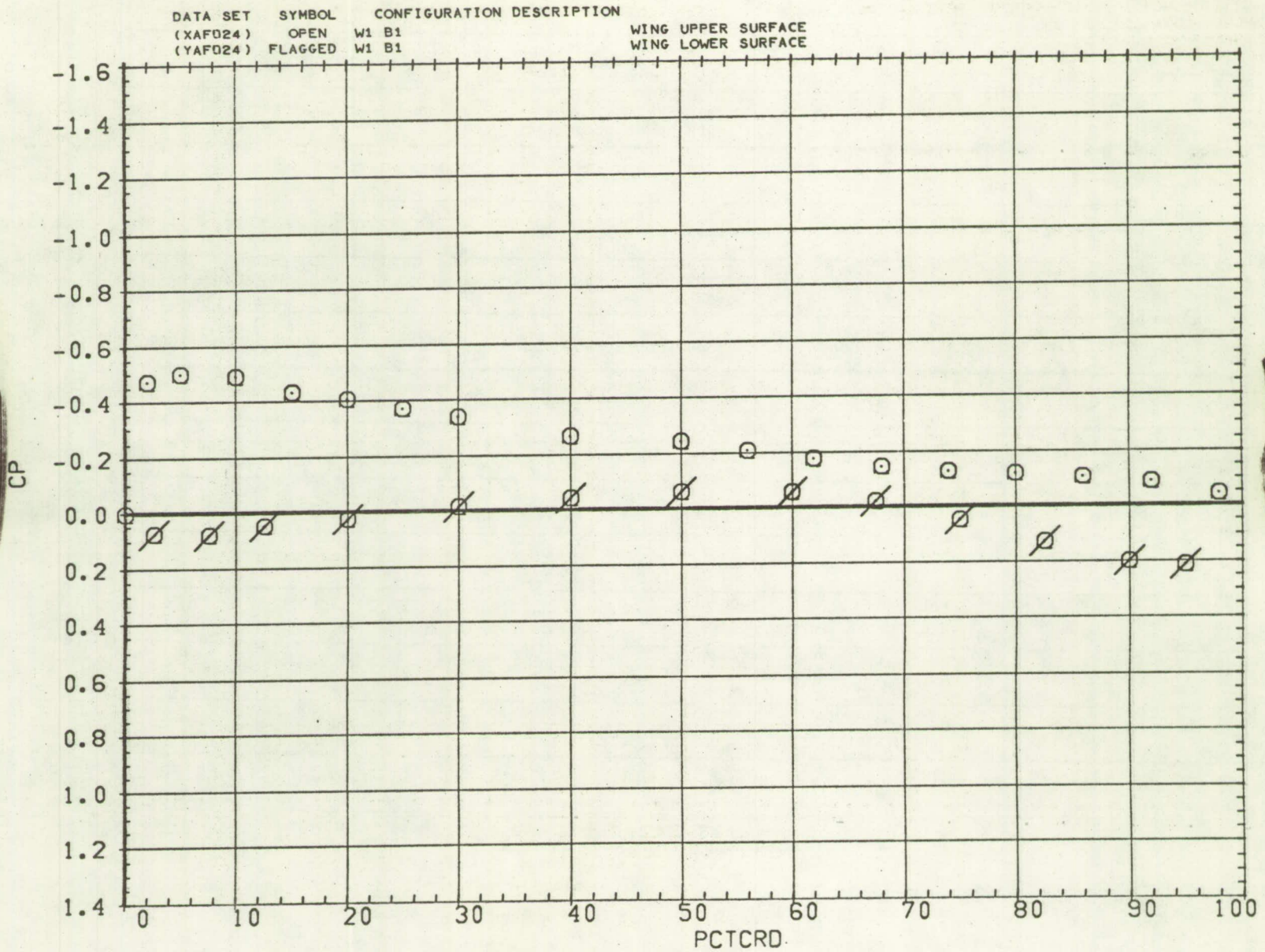

FIG. 19 WING PRESSURE DISTRIBUTION FOR BASIC WING-BODY

SYMBOL ALPHA BL MACH
 ○ - 0.050 7.768 0.500

PARAMETRIC VALUES
 BETA 0.000 SPLR-L 0.000
 TRANS 1.000 RN/L 4.000

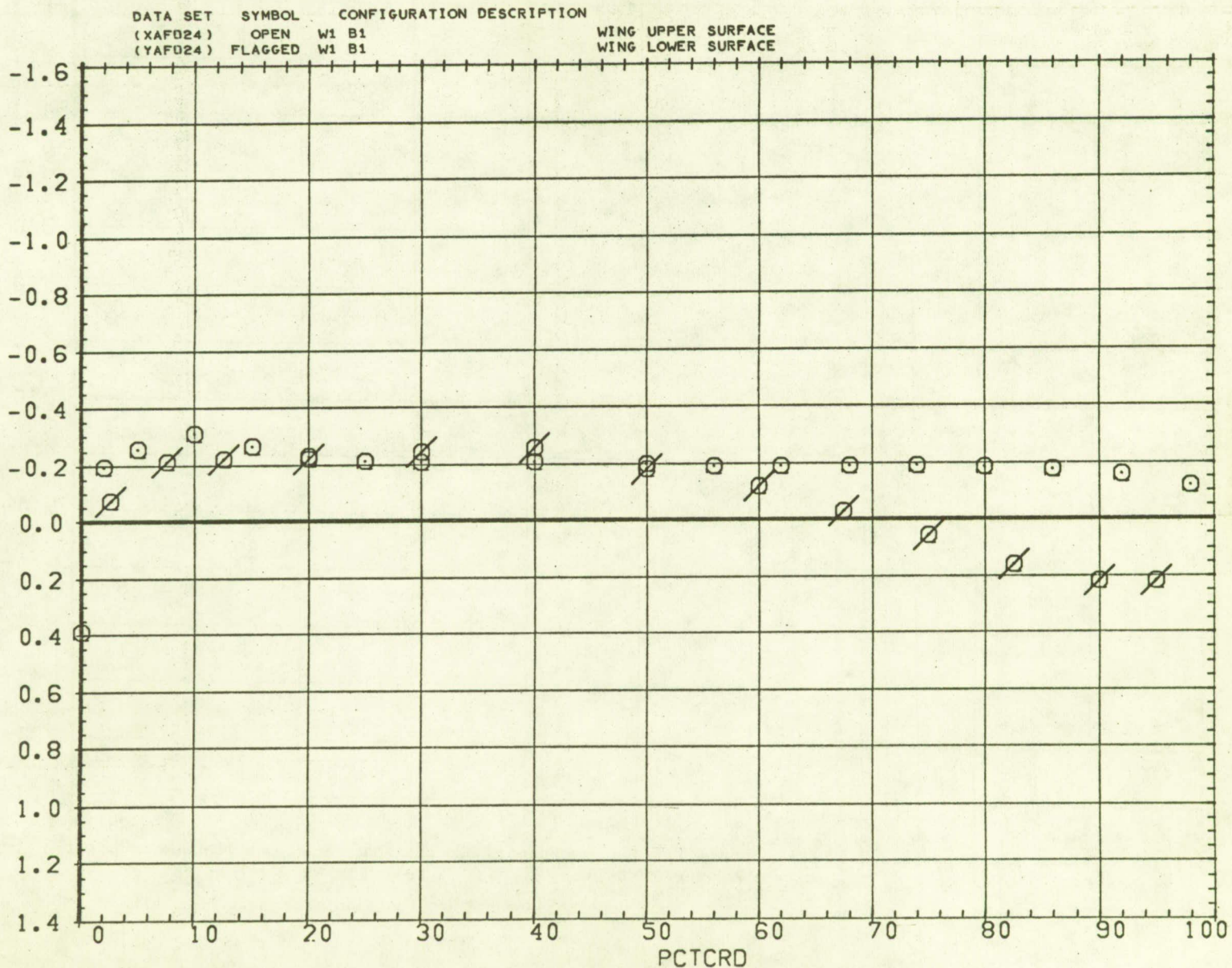

FIG. 19 WING PRESSURE DISTRIBUTION FOR BASIC WING-BODY

SYMBOL ALPHA BL MACH
 ○ 3.510 7.768 0.500

PARAMETRIC VALUES
 BETA 0.000 SPLR-L 0.000
 TRANS 1.000 RN/L 4.000

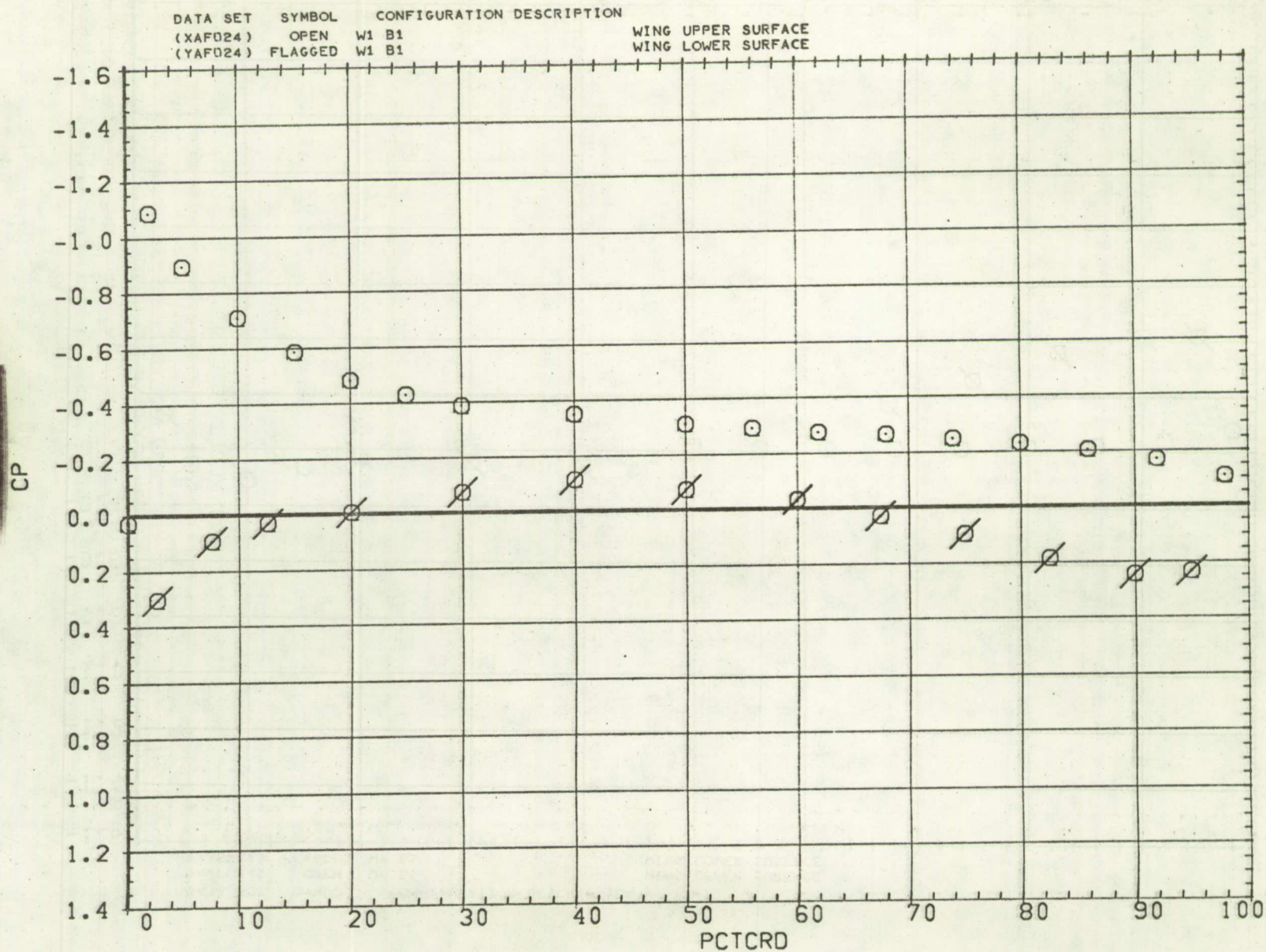

FIG. 19 WING PRESSURE DISTRIBUTION FOR BASIC WING-BODY

SYMBOL	ALPHA	BL	MACH
○	4.510	7.768	0.500

	PARAMETRIC VALUES		
BETA	0.000	SPLR-L	0.000
TRANS	1.000	RN/L	4.000

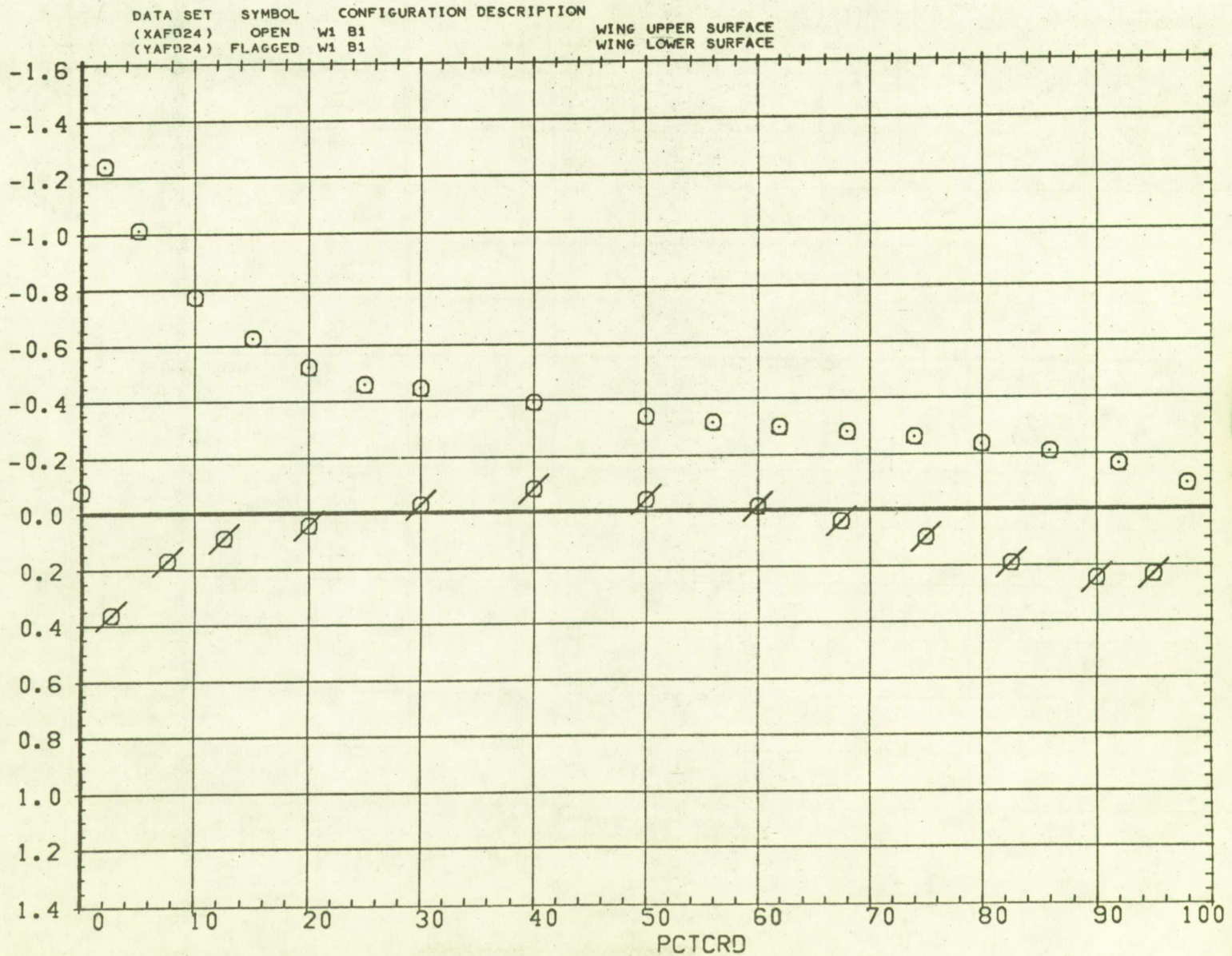

FIG. 19 WING PRESSURE DISTRIBUTION FOR BASIC WING-BODY

SYMBOL ALPHA BL MACH
 ○ - 0.050 11.424 0.500

PARAMETRIC VALUES
 BETA 0.000 SPLR-L 0.000
 TRANS 1.000 RN/L 4.000

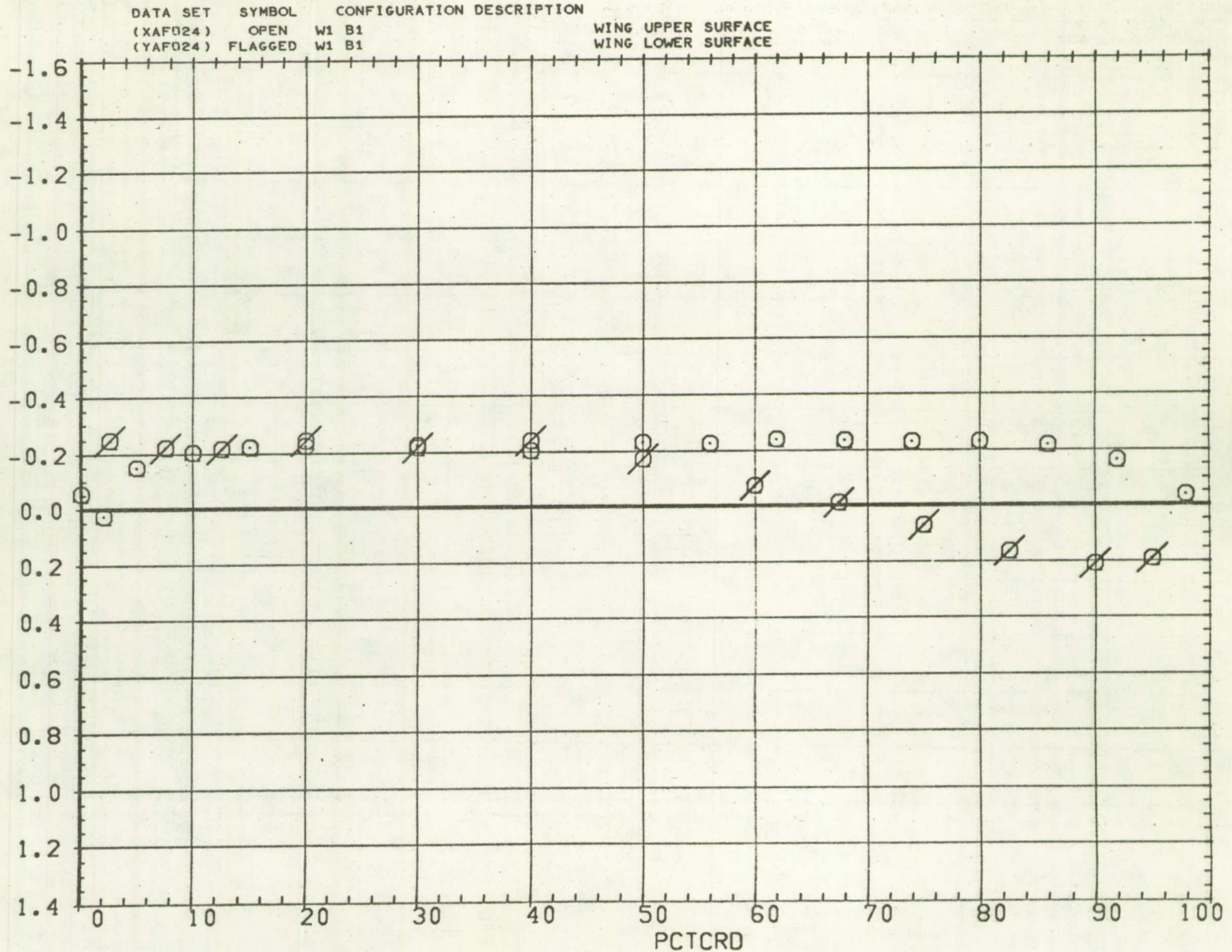

FIG. 19 WING PRESSURE DISTRIBUTION FOR BASIC WING-BODY

SYMBOL ALPHA BL MACH
 ○ 3.510 11.424 0.500

PARAMETRIC VALUES
 BETA 0.000 SPLR-L 0.000
 TRANS 1.000 RN/L 4.000

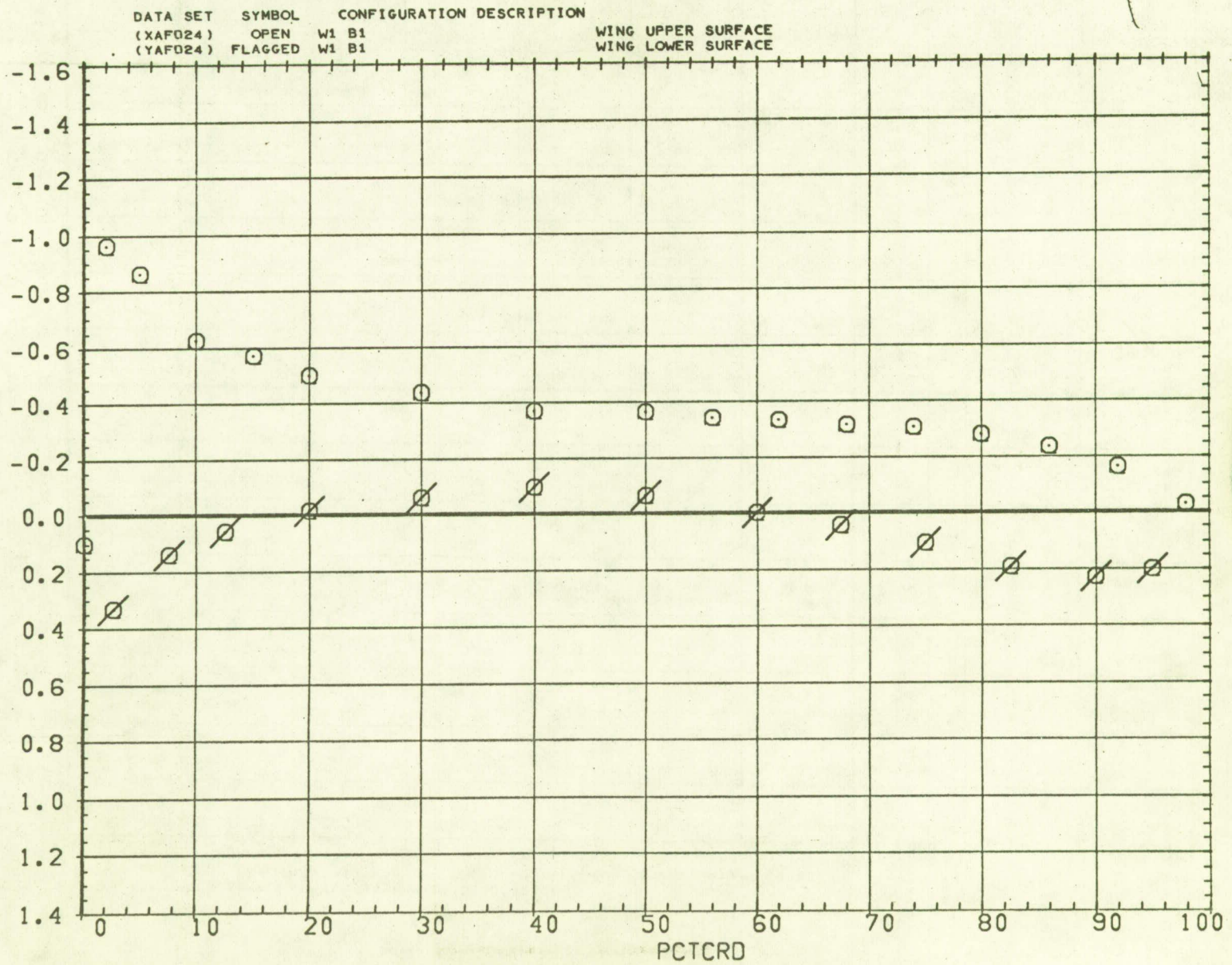

FIG. 19 WING PRESSURE DISTRIBUTION FOR BASIC WING-BODY

SYMBOL ALPHA BL MACH
 ○ 4.510 11.424 0.500

PARAMETRIC VALUES
 BETA 0.000 SPLR-L 0.000
 TRANS 1.000 RN/L 4.000

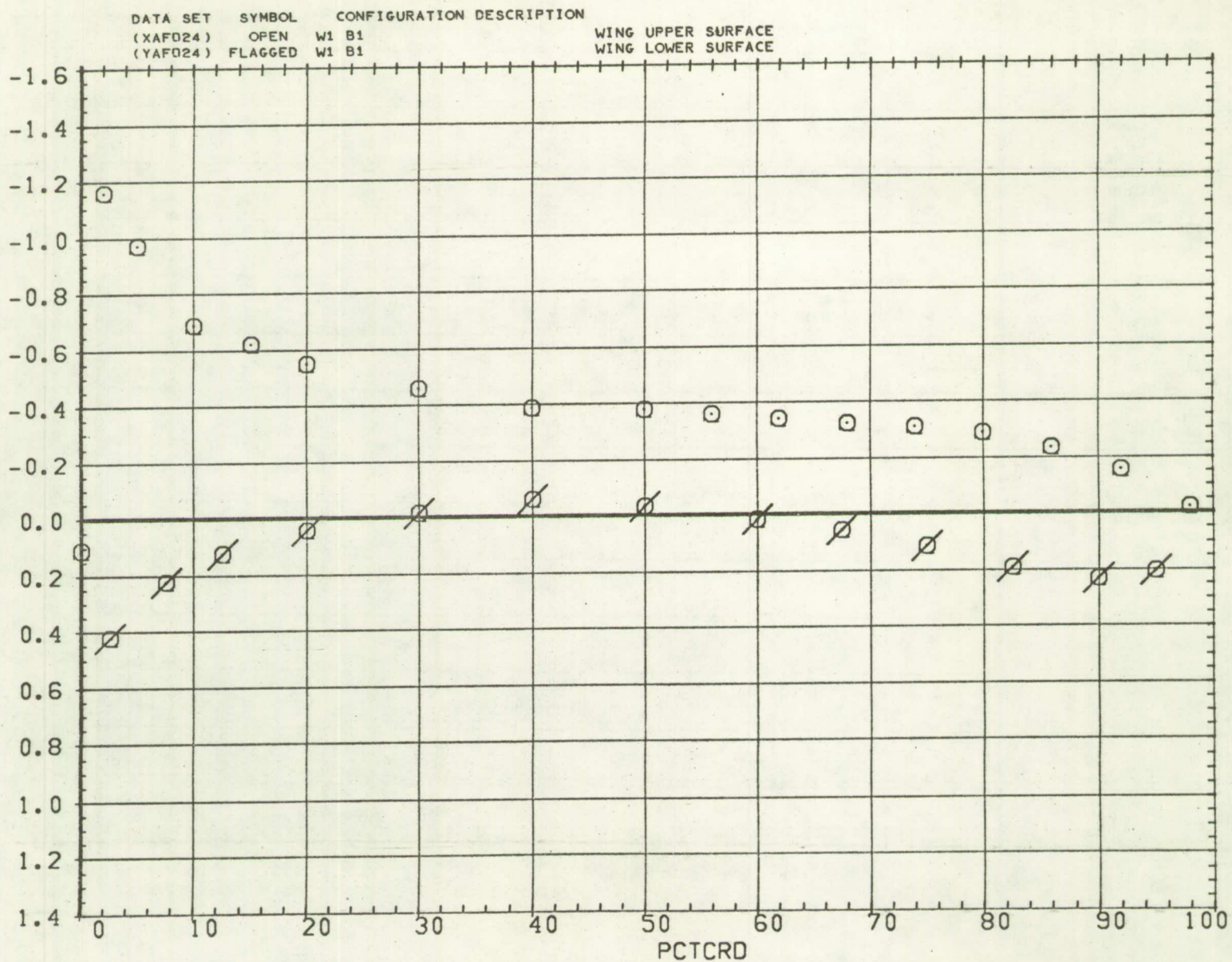

FIG. 19 WING PRESSURE DISTRIBUTION FOR BASIC WING-BODY

SYMBOL ALPHA BL MACH
 ○ - 0.050 18.278 0.500

PARAMETRIC VALUES
 BETA 0.000 SPLR-L 0.000
 TRANS 1.000 RN/L 4.000

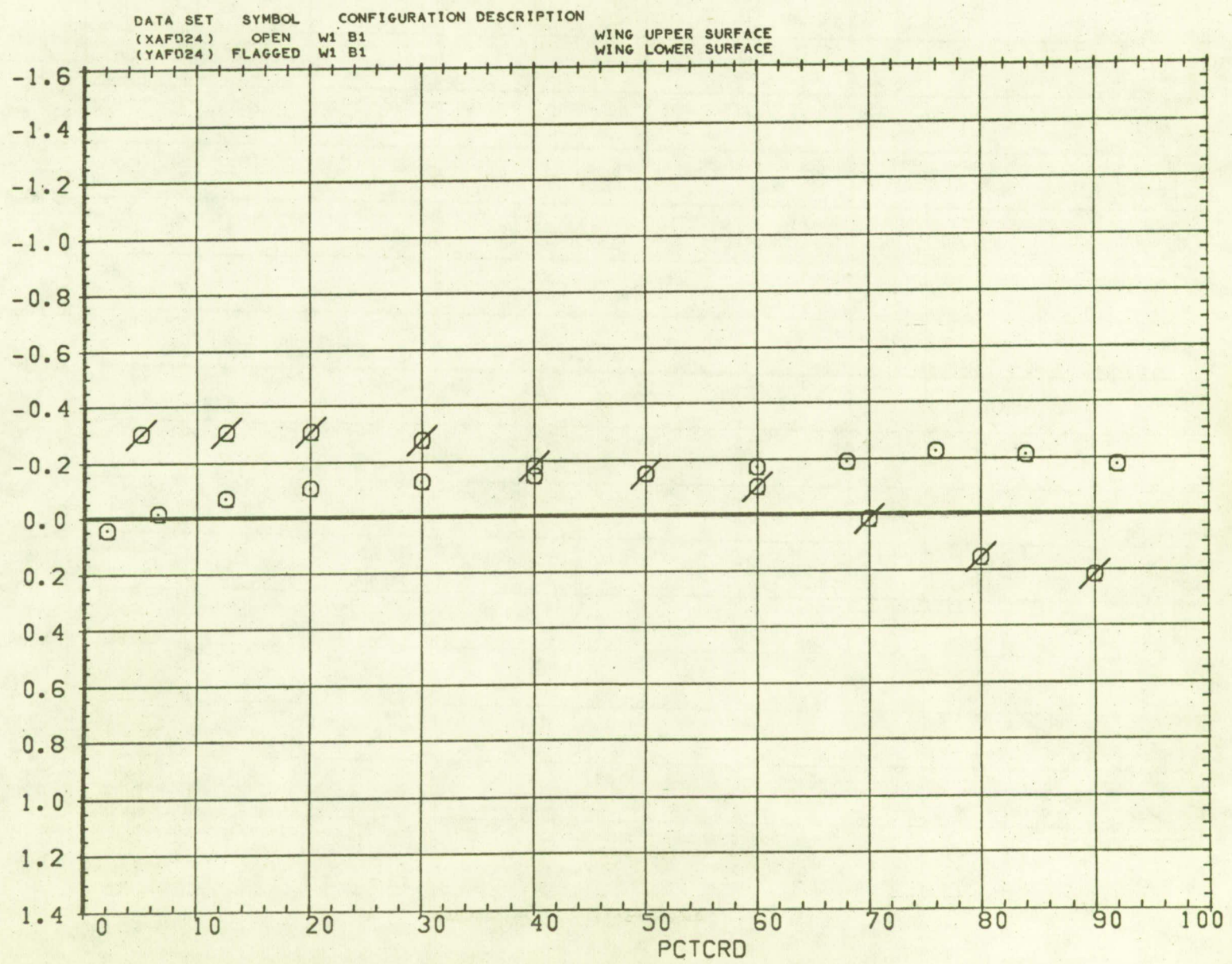

FIG. 19 WING PRESSURE DISTRIBUTION FOR BASIC WING-BODY

SYMBOL ALPHA BL MACH
 ○ 3.510 18.278 0.500

PARAMETRIC VALUES
 BETA 0.000 SPLR-L 0.000
 TRANS 1.000 RN/L 4.000

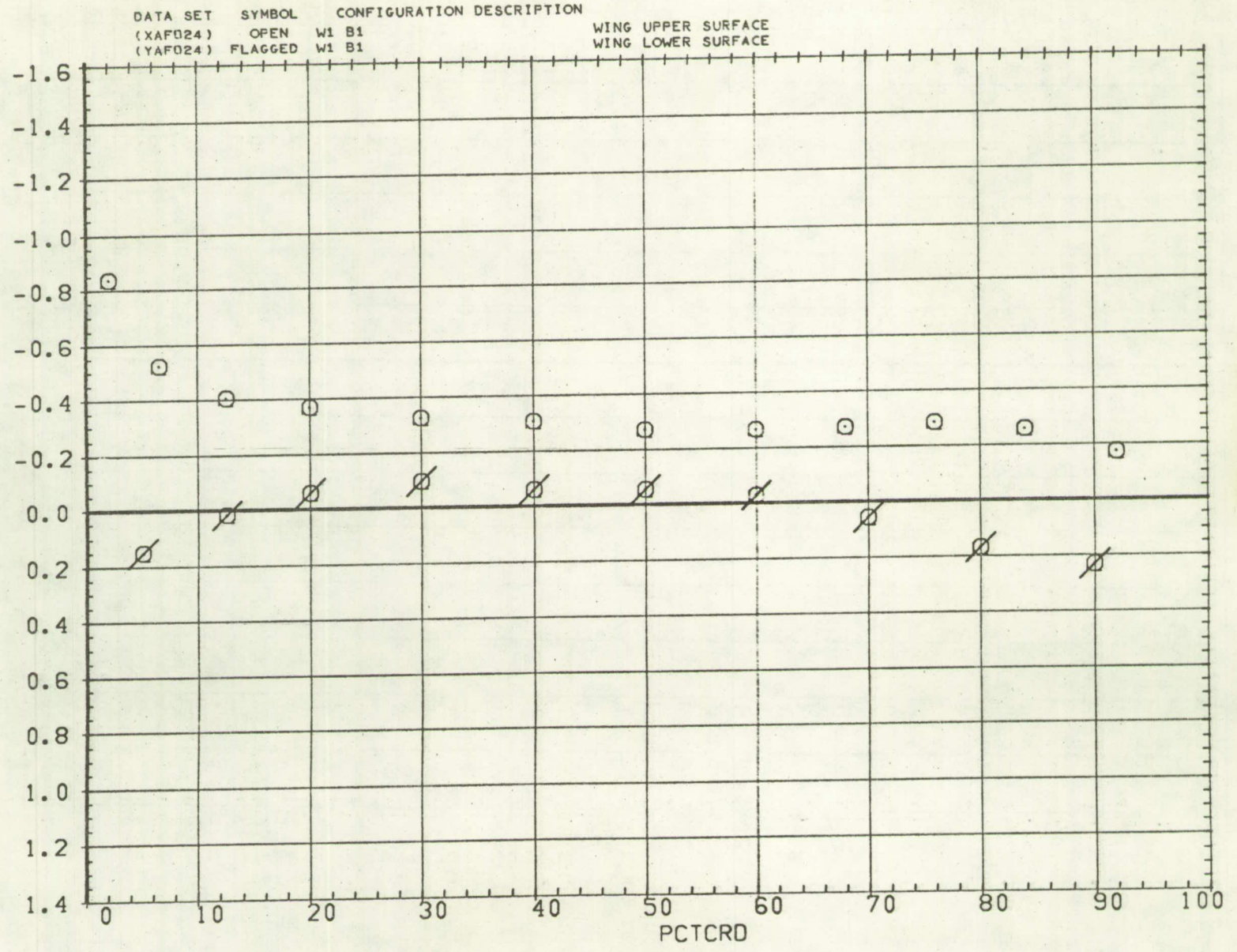

FIG. 19 WING PRESSURE DISTRIBUTION FOR BASIC WING-BODY

SYMBOL ALPHA BL MACH
 ○ 4.510 18.278 0.500

PARAMETRIC VALUES
 BETA 0.000 SPLR-L 0.000
 TRANS 1.000 RN/L 4.000

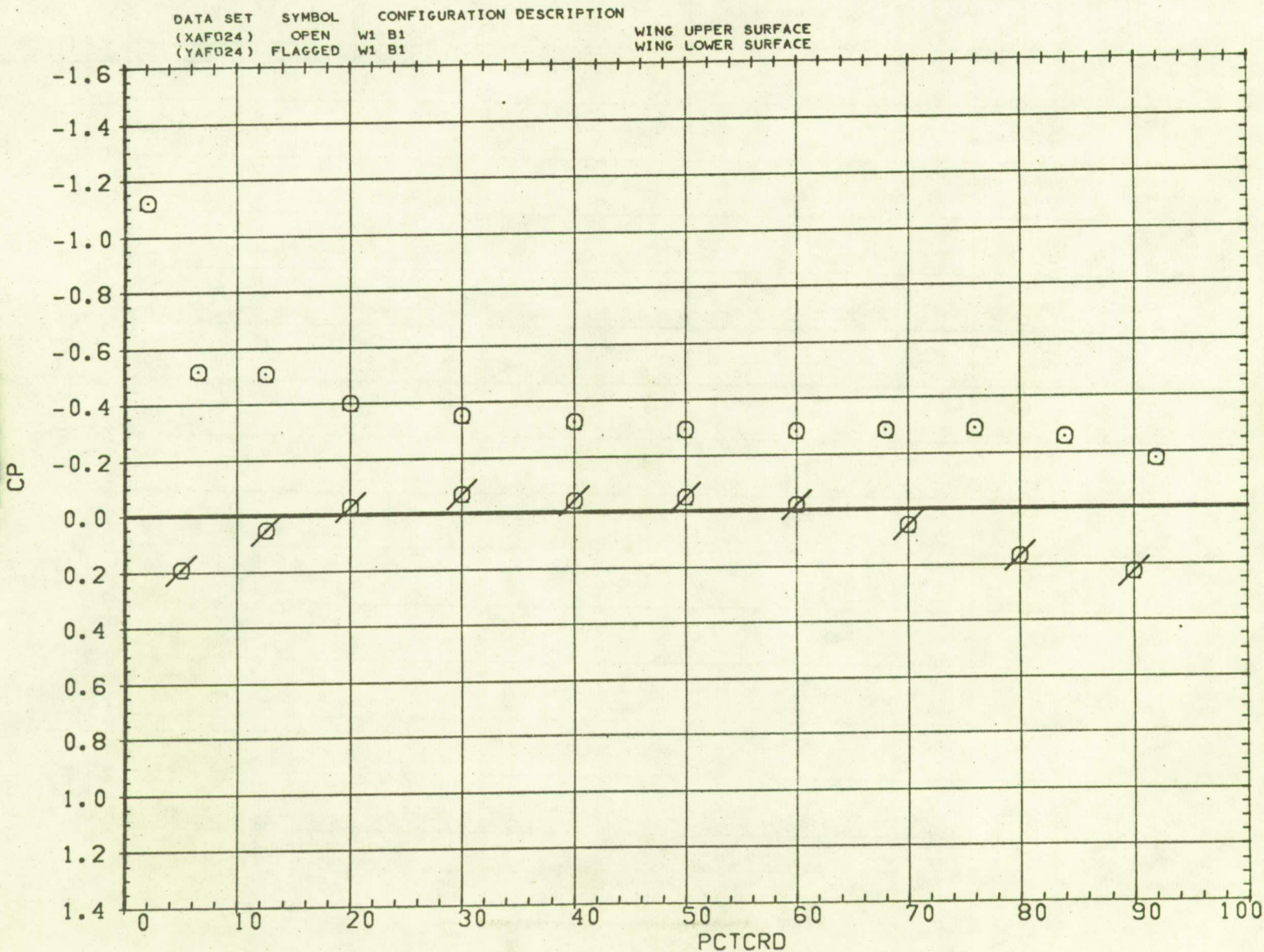

FIG. 19 WING PRESSURE DISTRIBUTION FOR BASIC WING-BODY

SYMBOL	ALPHA	BL	MACH
○	0.040	4.250	0.801

PARAMETRIC VALUES			
BETA	0.000	SPLR-L	0.000
TRANS	1.000	RN/L	4.000

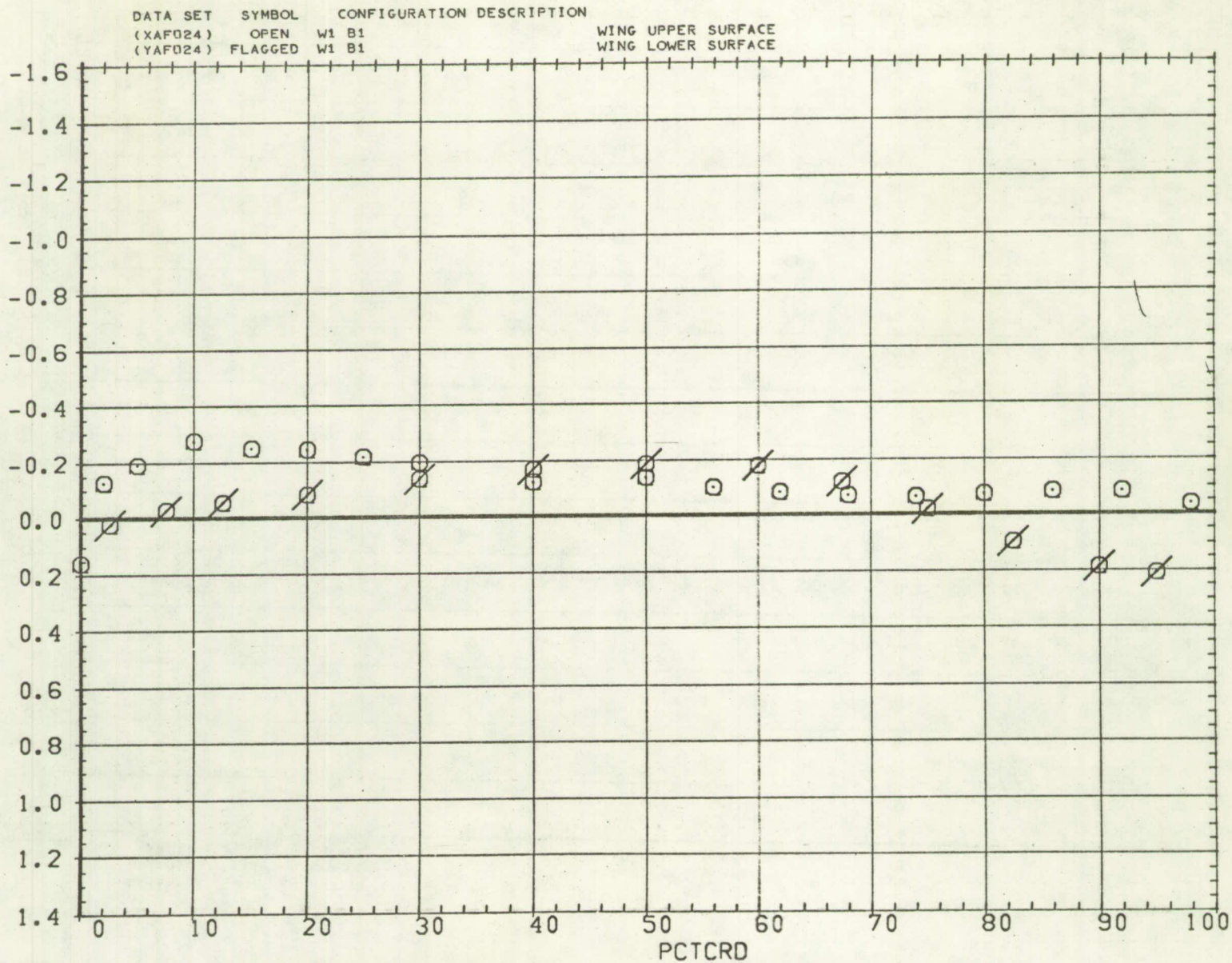

FIG. 19 WING PRESSURE DISTRIBUTION FOR BASIC WING-BODY

SYMBOL ALPHA BL MACH
 ○ 3.530 4.250 0.801

PARAMETRIC VALUES
 BETA 0.000 SFLR-L 0.000
 TRANS 1.000 RN/L 4.000

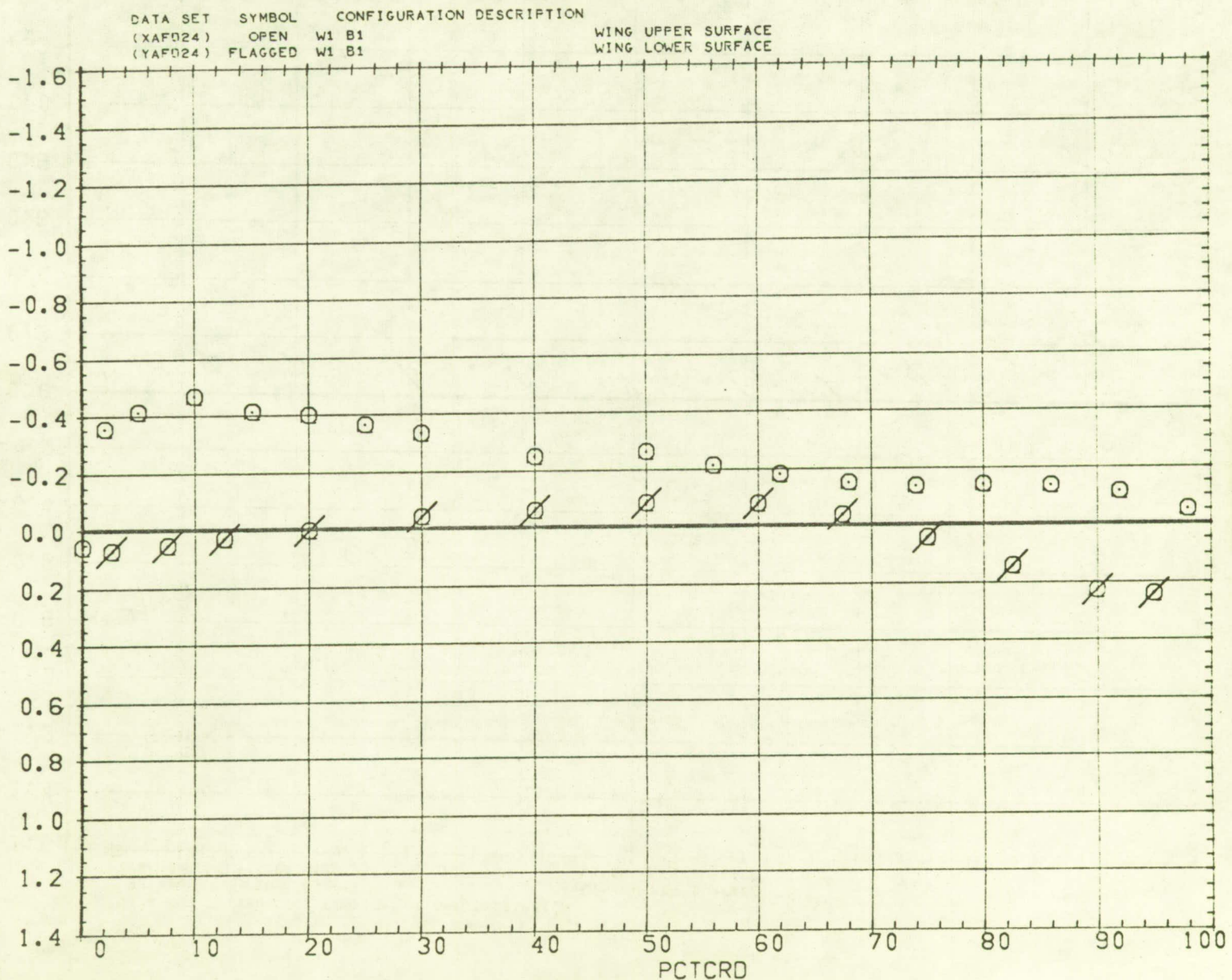

FIG. 19 WING PRESSURE DISTRIBUTION FOR BASIC WING-BODY

SYMBOL ALPHA BL MACH
 ○ 7.990 4.250 0.801

PARAMETRIC VALUES
 BETA 0.000 SFLR-L 0.000
 TRANS 1.000 RN/L 4.000

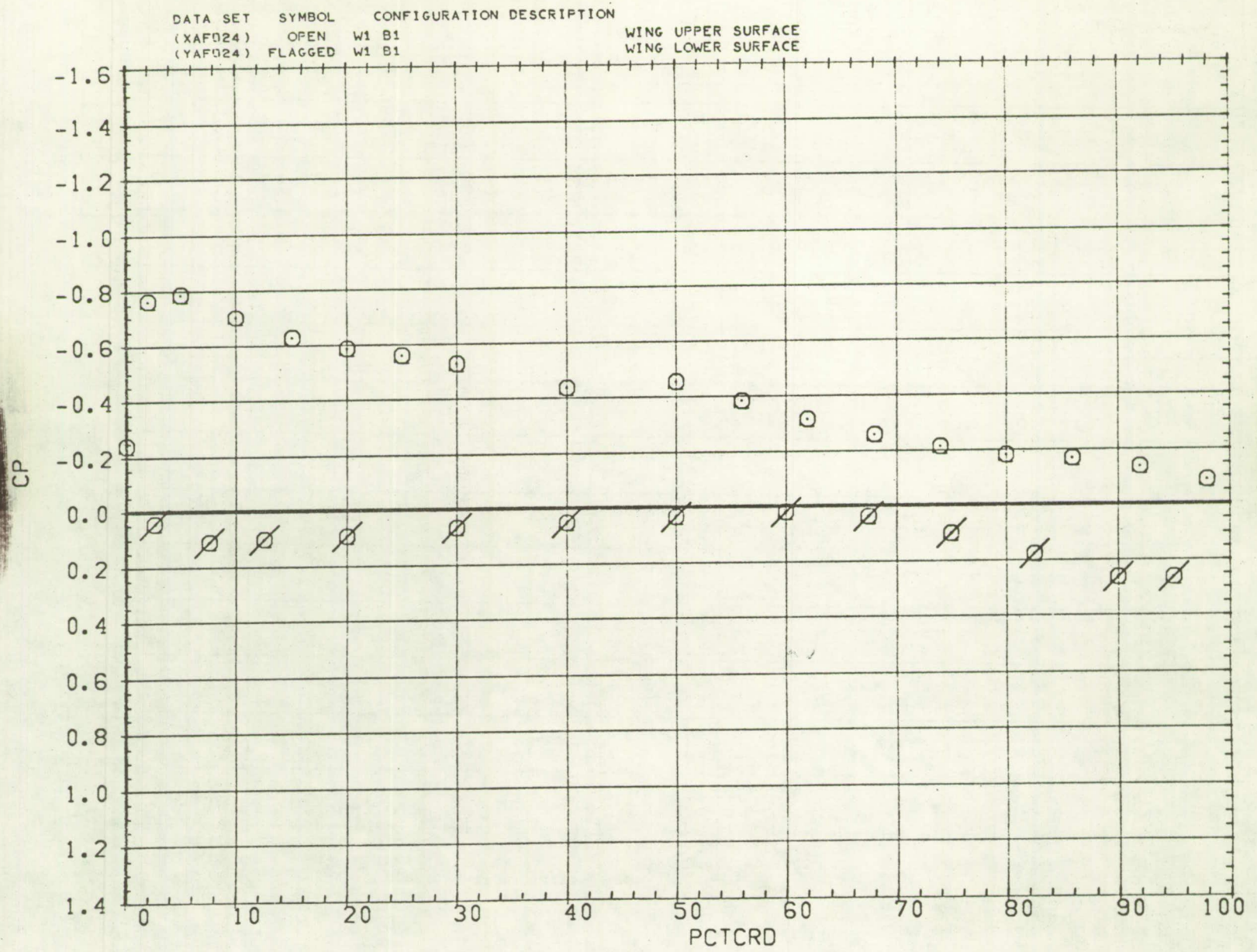

FIG. 19 WING PRESSURE DISTRIBUTION FOR BASIC WING-BODY

SYMBOL ALPHA BL MACH
 ○ - 0.040 7.768 0.801

PARAMETRIC VALUES
 BETA 0.000 SPLR-L 0.000
 TRANS 1.000 RN/L 4.000

DATA SET SYMBOL CONFIGURATION DESCRIPTION
 (XAF024) OPEN W1 B1 WING UPPER SURFACE
 (YAF024) FLAGGED W1 B1 WING LOWER SURFACE

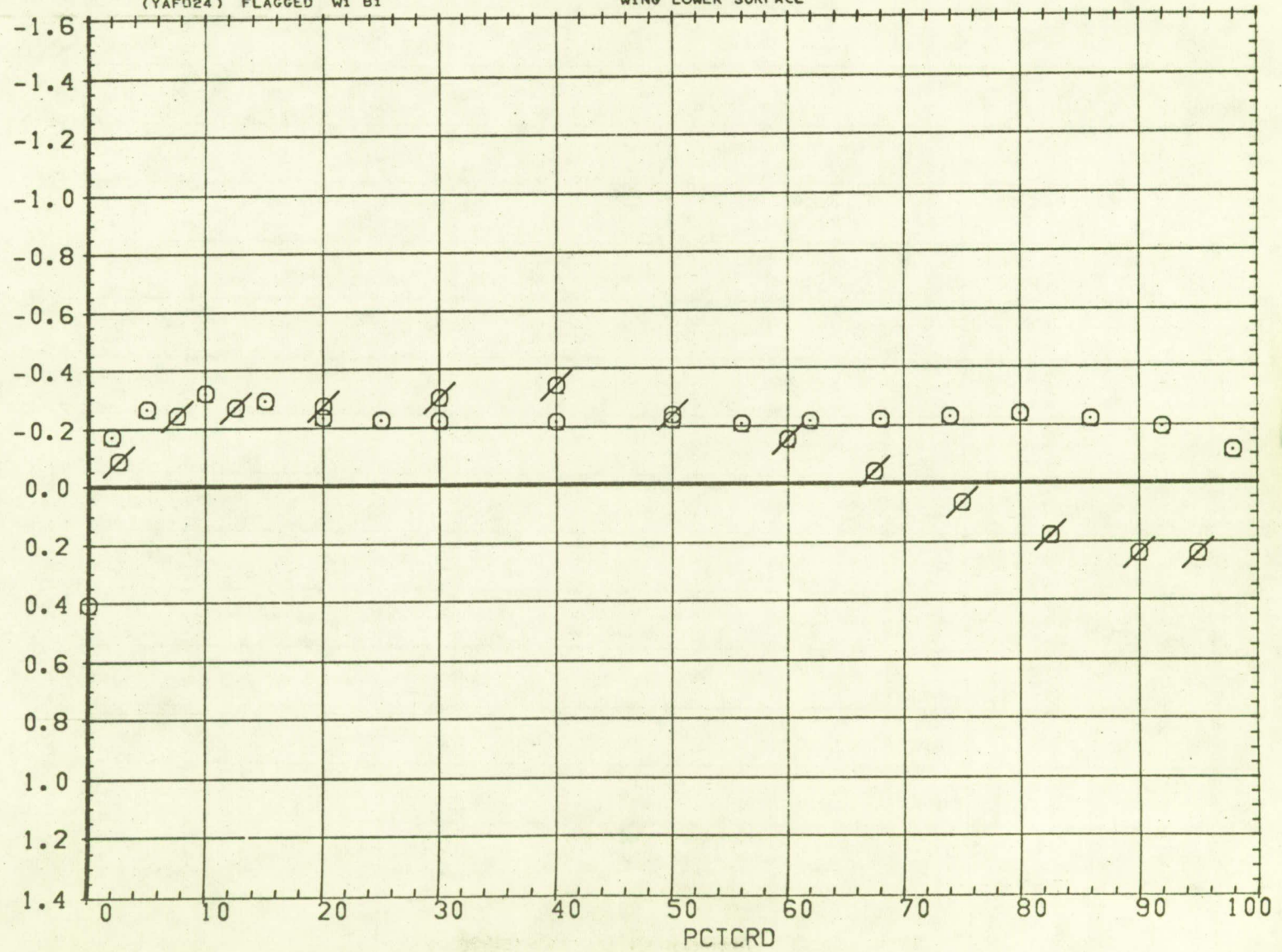

FIG. 19 WING PRESSURE DISTRIBUTION FOR BASIC WING-BODY

SYMBOL ALPHA BL MACH
 ○ 3.530 7.768 0.801

PARAMETRIC VALUES
 BETA 0.000 SPLR-L 0.000
 TRANS 1.000 RN/L 4.000

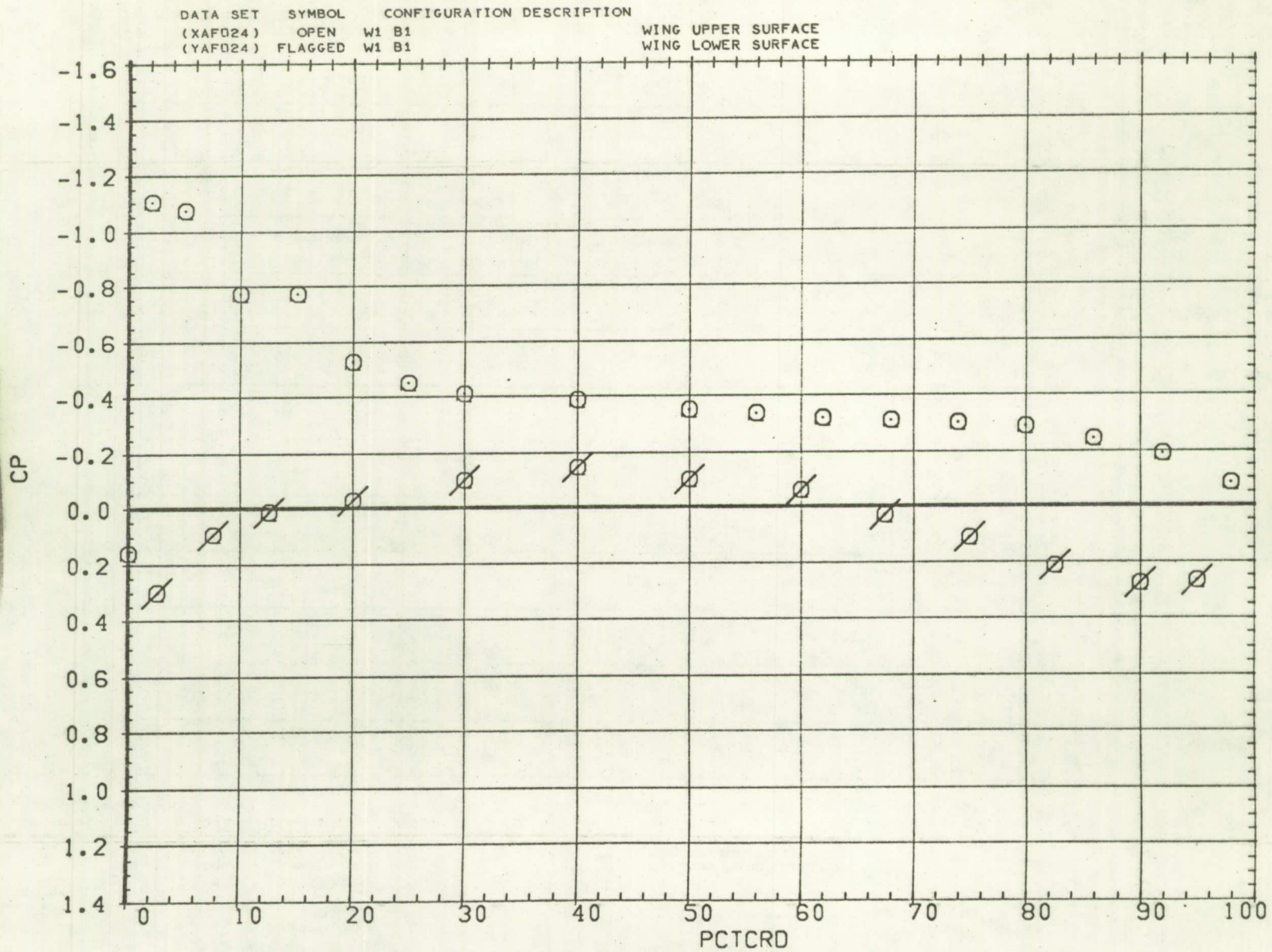

FIG. 19 WING PRESSURE DISTRIBUTION FOR BASIC WING-BODY

SYMBOL	ALPHA	BL	MACH
○	7.990	7.768	0.801

	PARAMETRIC VALUES		
BETA	0.000	SPLR-L	0.000
TRANS	1.000	RN/L	4.000

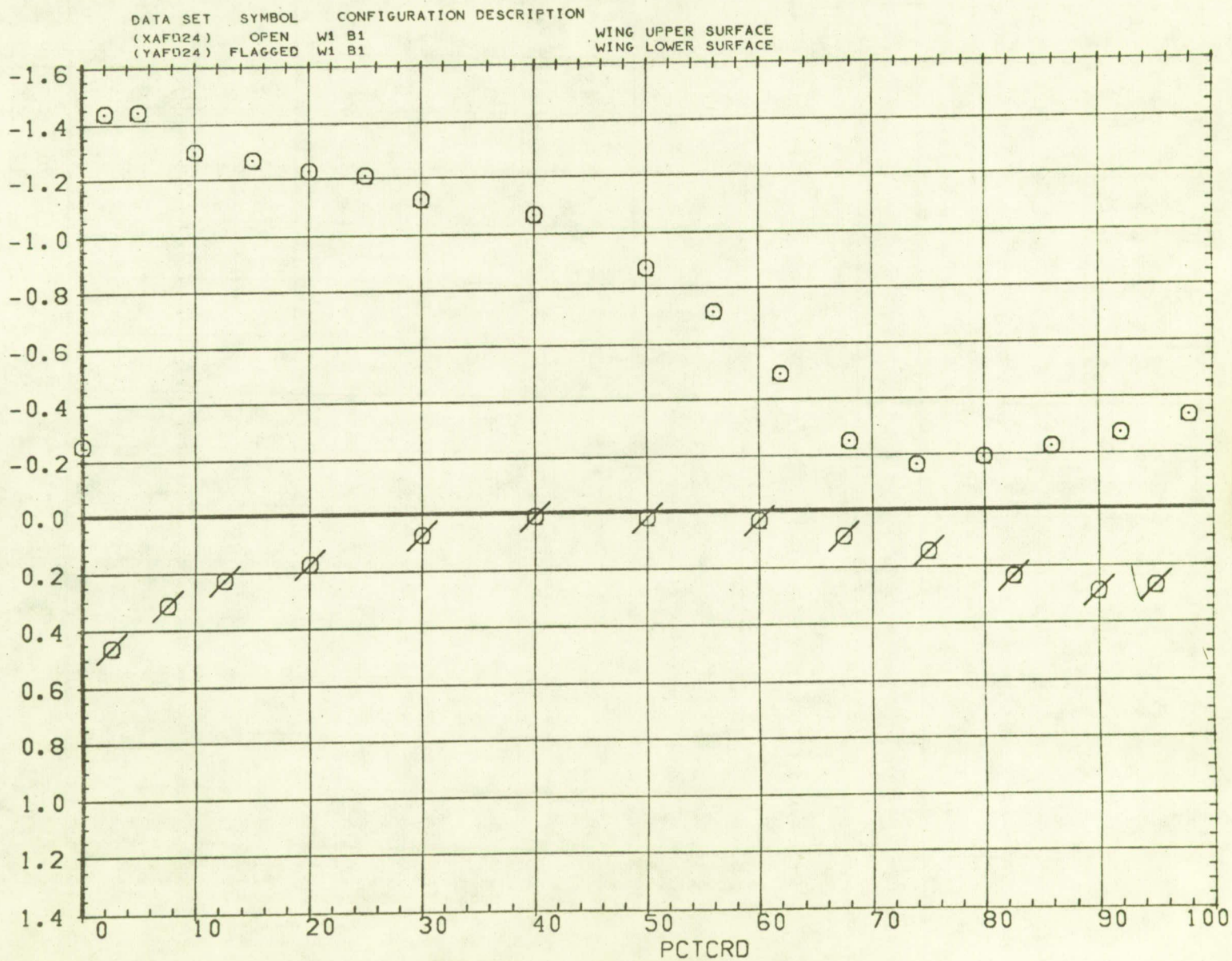

FIG. 19 WING PRESSURE DISTRIBUTION FOR BASIC WING-BODY

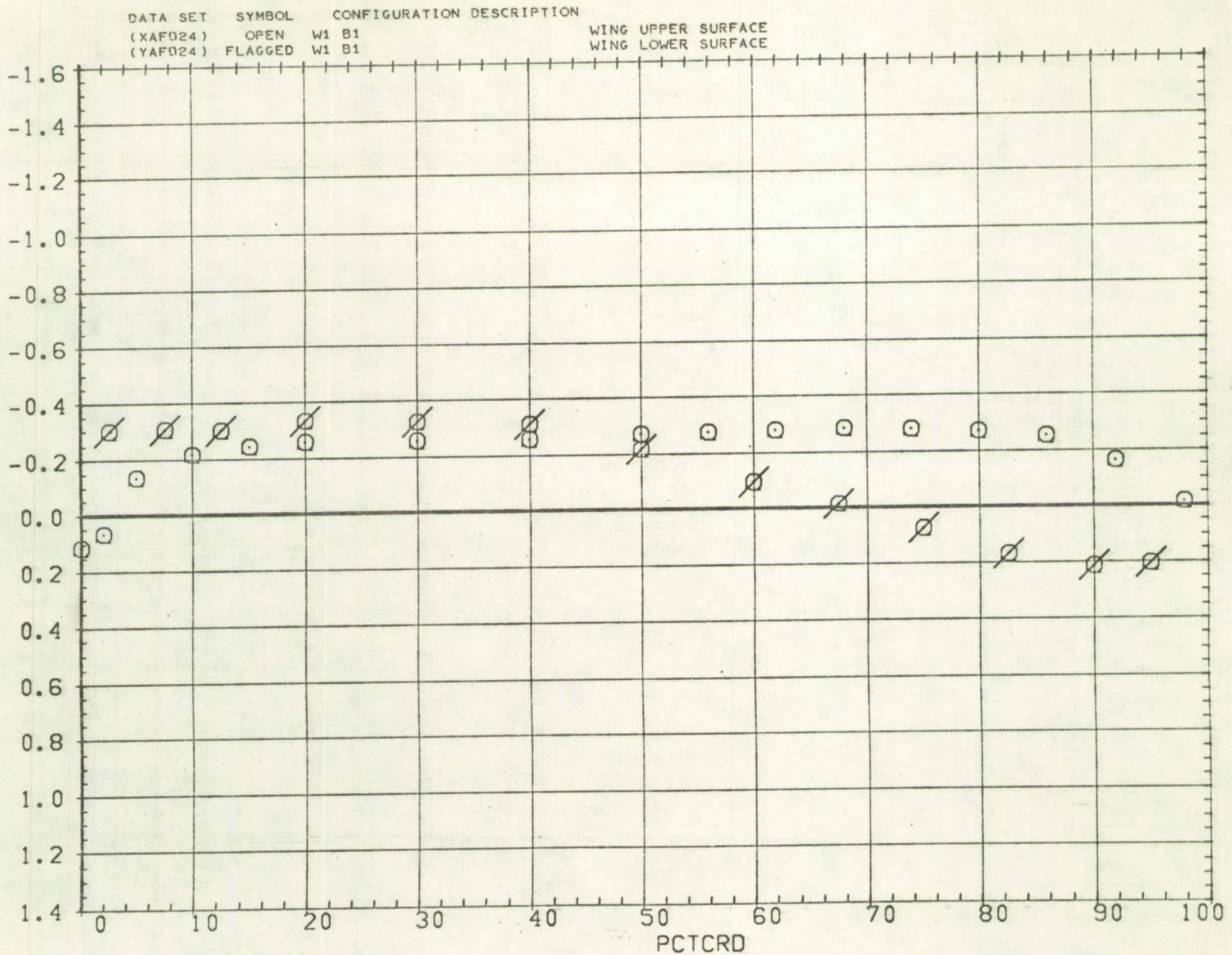

FIG. 19 WING PRESSURE DISTRIBUTION FOR BASIC WING-BODY

SYMBOL ALPHA BL MACH
 ○ 3.530 11.424 0.801

PARAMETRIC VALUES
 BETA 0.000 SPLR-L 0.000
 TRANS 1.000 RN/L 4.000

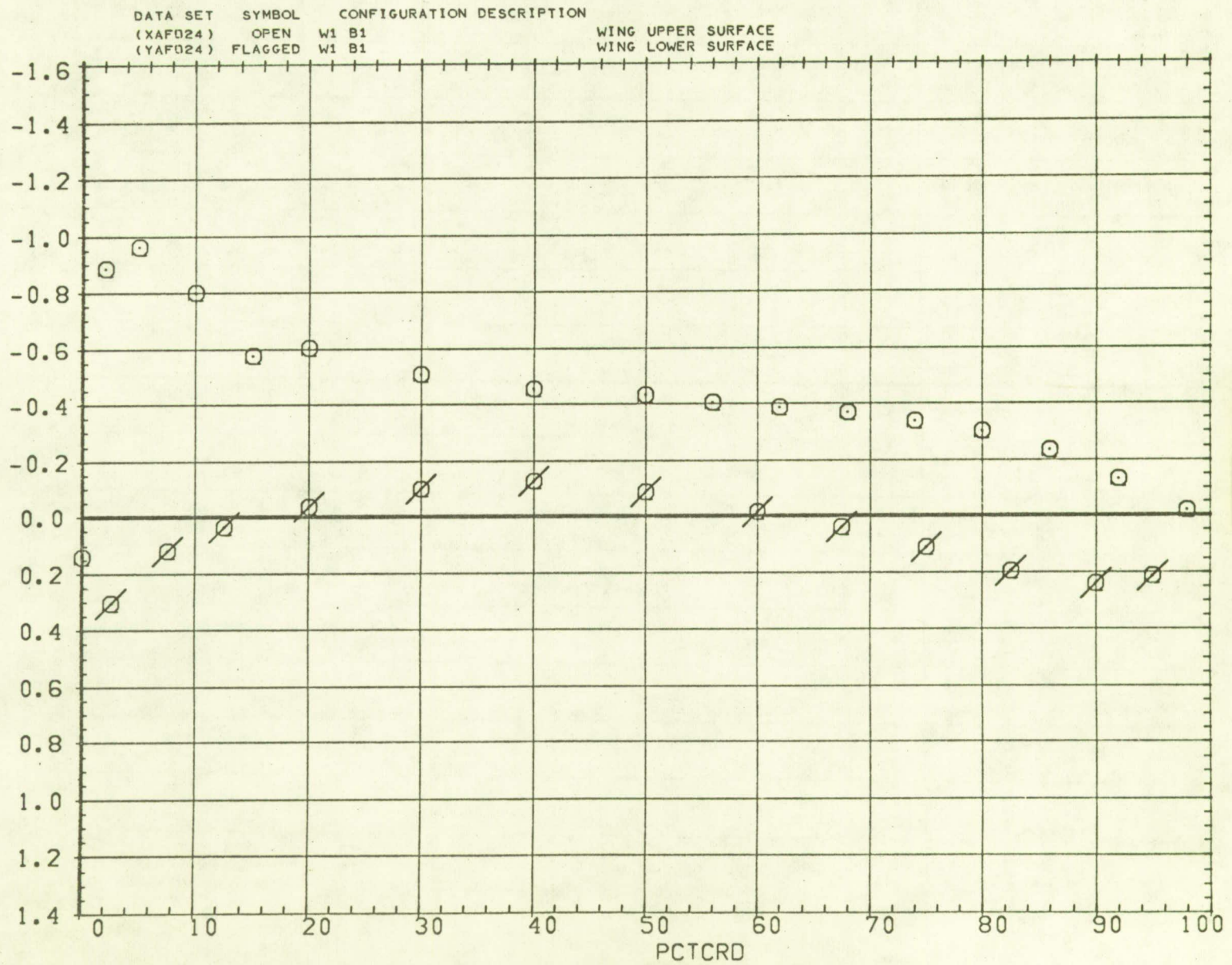

FIG. 19 WING PRESSURE DISTRIBUTION FOR BASIC WING-BODY

SYMBOL ALPHA BL MACH
 ○ 7.990 11.424 0.801

PARAMETRIC VALUES
 BETA 0.000 SPLR-L 0.000
 TRANS 1.000 RN/L 4.000

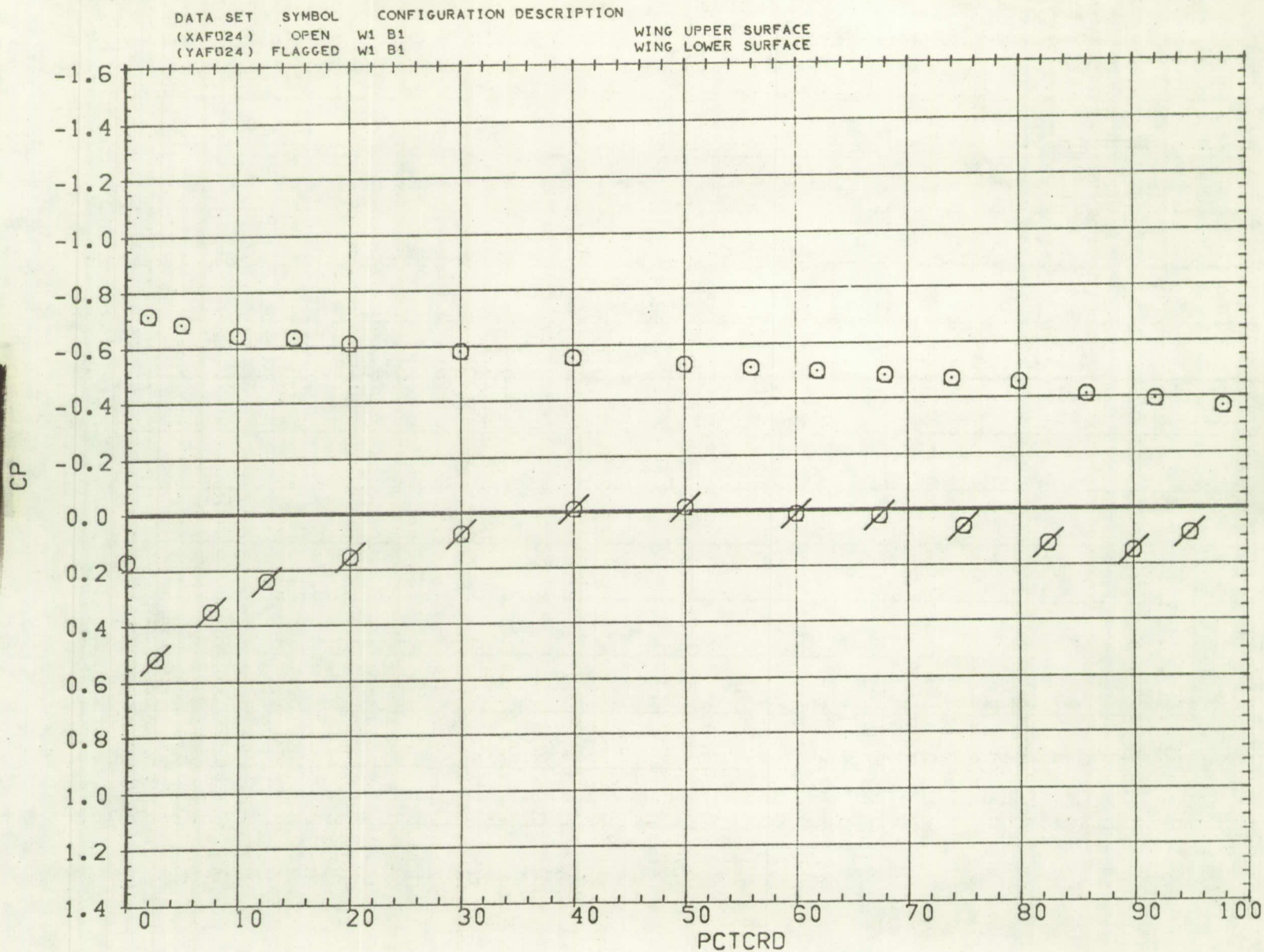

FIG. 19 WING PRESSURE DISTRIBUTION FOR BASIC WING-BODY

SYMBOL ALPHA BL MACH
 ○ - 0.040 18.278 0.801

PARAMETRIC VALUES
 BETA 0.000 SPLR-L 0.000
 TRANS 1.000 RN/L 4.000

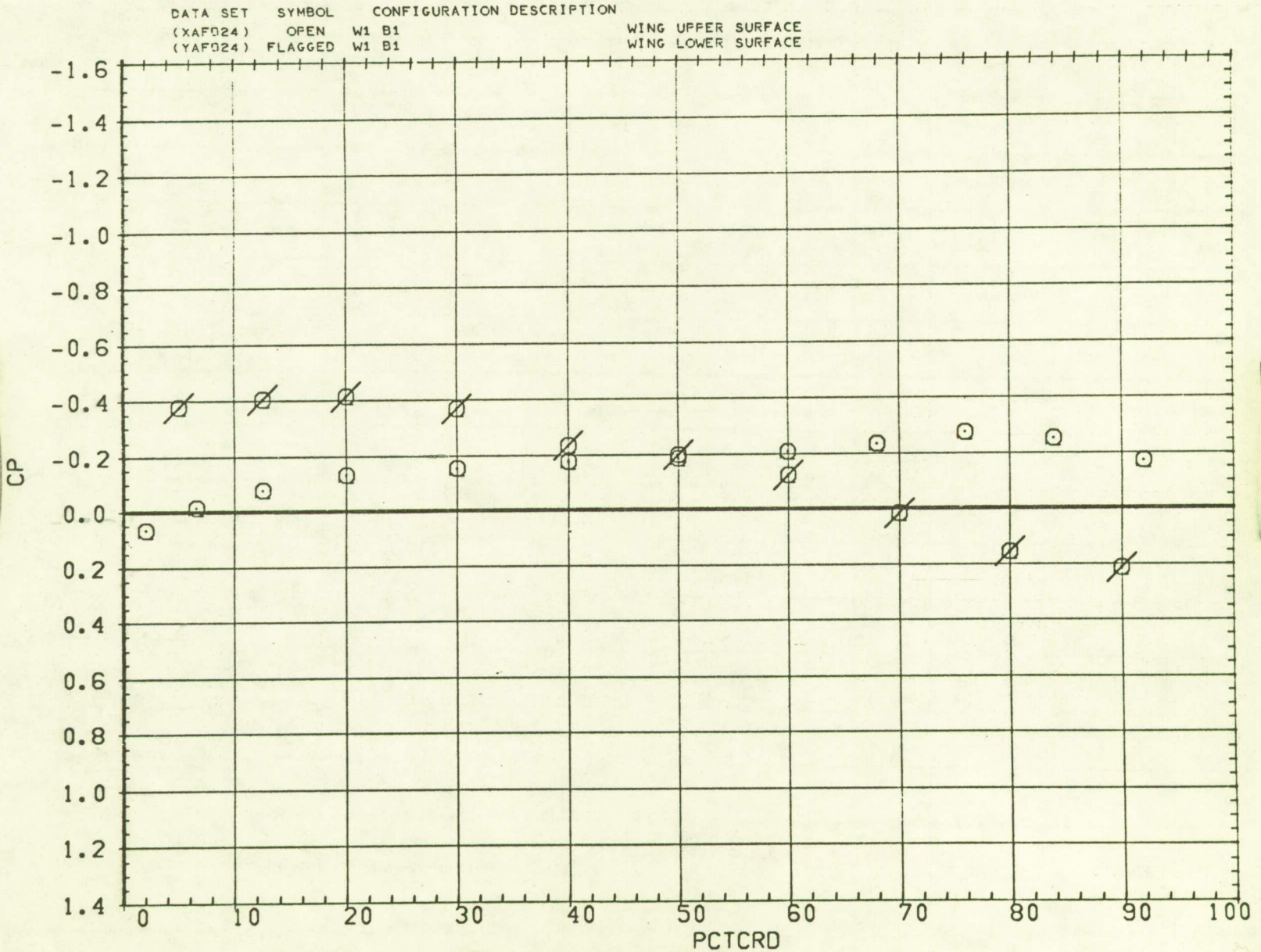

FIG. 19 WING PRESSURE DISTRIBUTION FOR BASIC WING-BODY

SYMBOL ALPHA BL MACH
 O 3.530 18.278 0.801

PARAMETRIC VALUES
 BETA 0.000 SPLR-L 0.000
 TRANS 1.000 RN/L 4.000

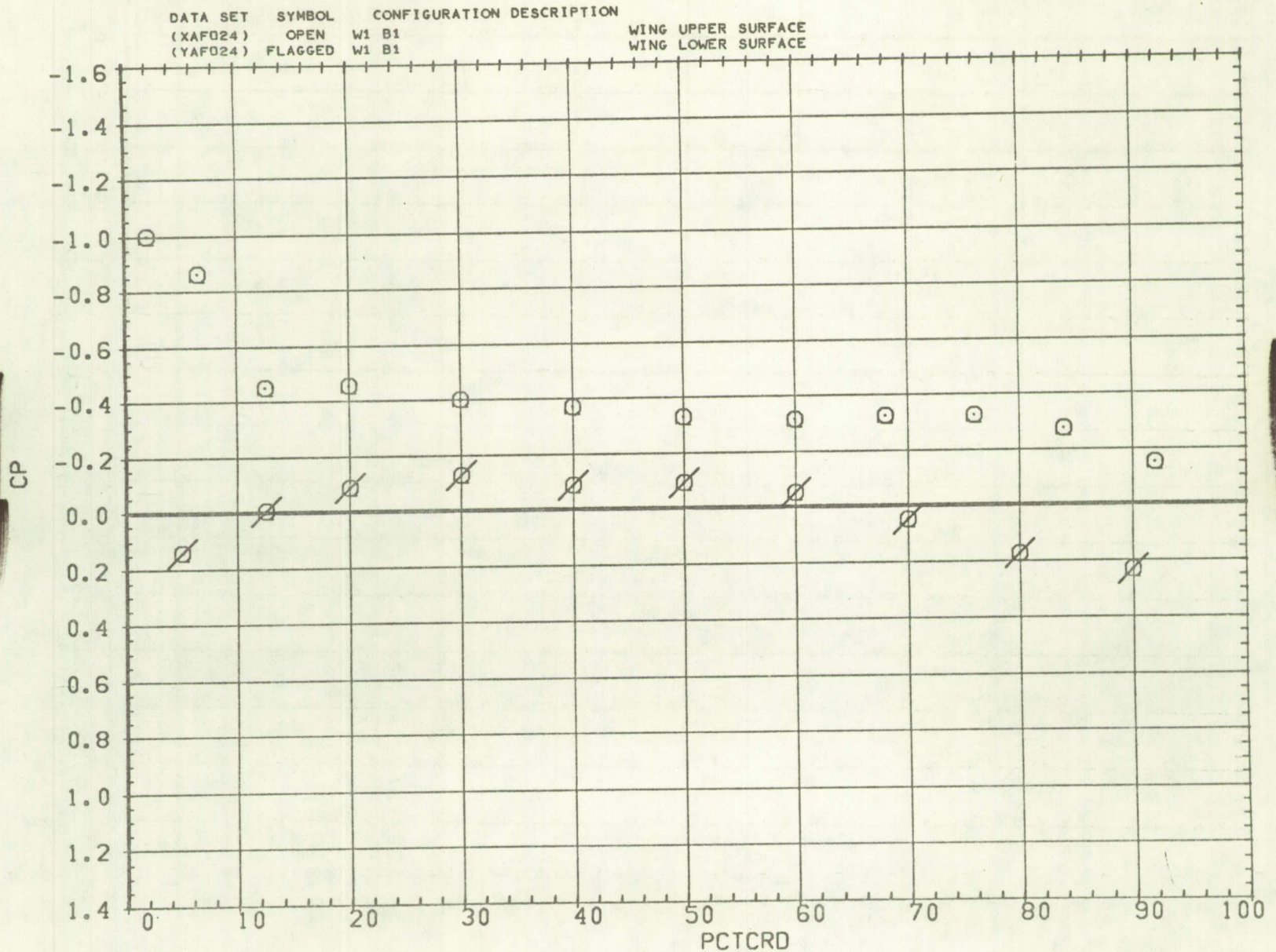

FIG. 19 WING PRESSURE DISTRIBUTION FOR BASIC WING-BODY

SYMBOL ALPHA BL MACH
 ○ 7.990 18.278 0.801

PARAMETRIC VALUES
 BETA 0.000 SPLR-L 0.000
 TRANS 1.000 RN/L 4.000

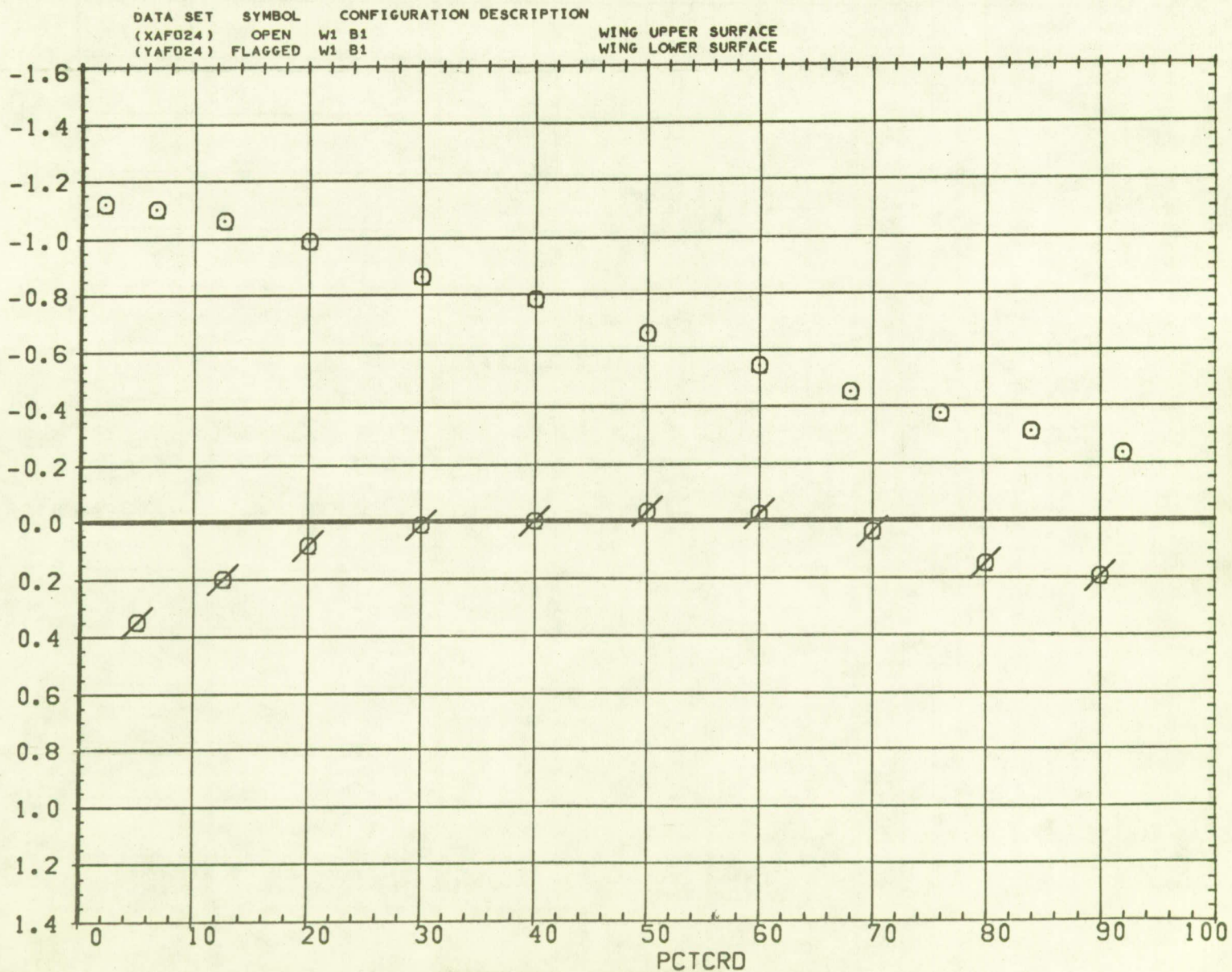

FIG. 19 WING PRESSURE DISTRIBUTION FOR BASIC WING-BODY

SYMBOL ALPHA BL MACH
 O 0.000 4.250 0.902

PARAMETRIC VALUES
 BETA 0.000 SPLR-L 0.000
 TRANS 1.000 RN/L 4.000

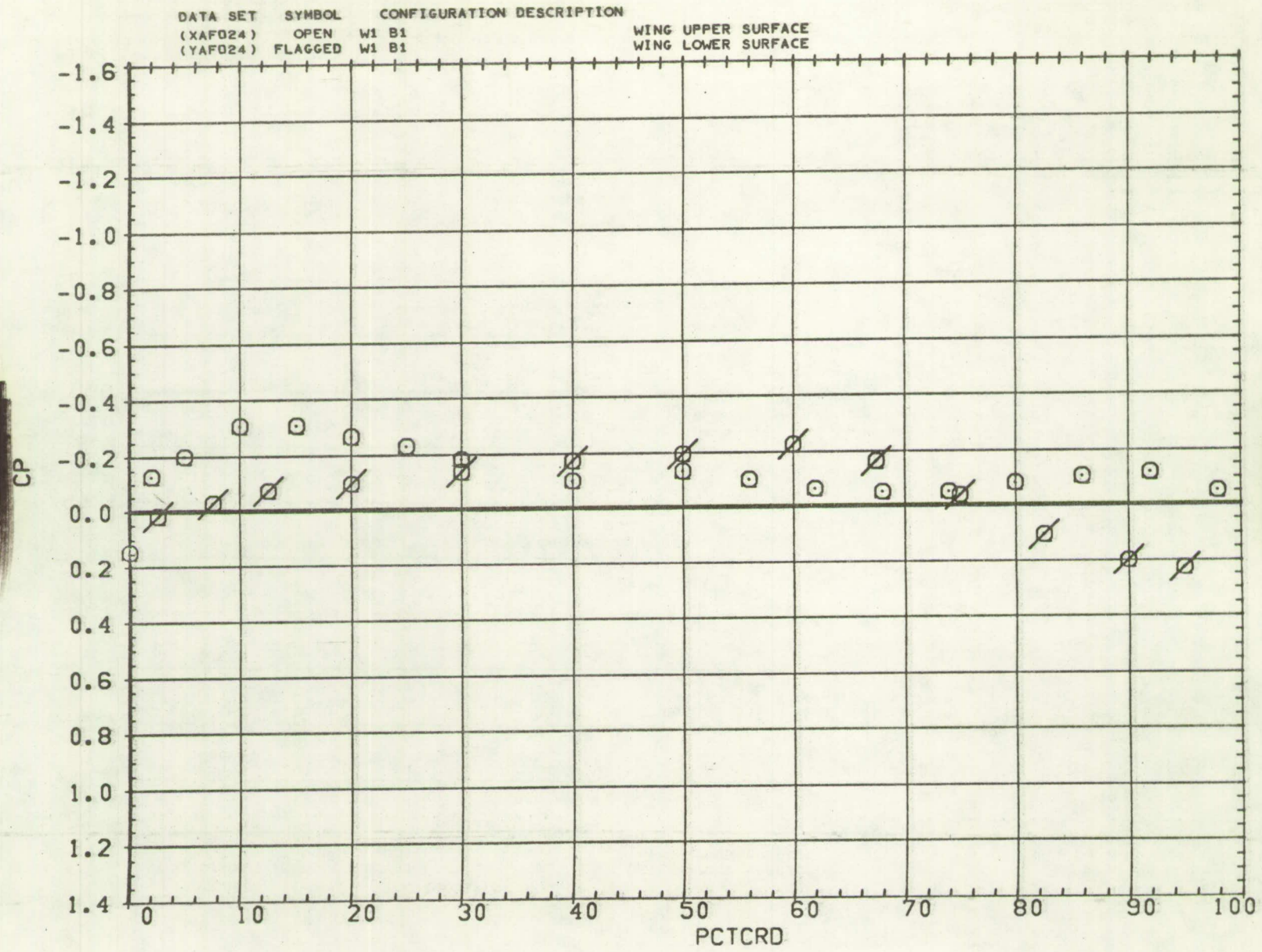

FIG. 19 WING PRESSURE DISTRIBUTION FOR BASIC WING-BODY

SYMBOL ALPHA BL MACH
 ○ 3.550 4.250 0.902

PARAMETRIC VALUES
 BETA 0.000 SPLR-L 0.000
 TRANS 1.000 RN/L 4.000

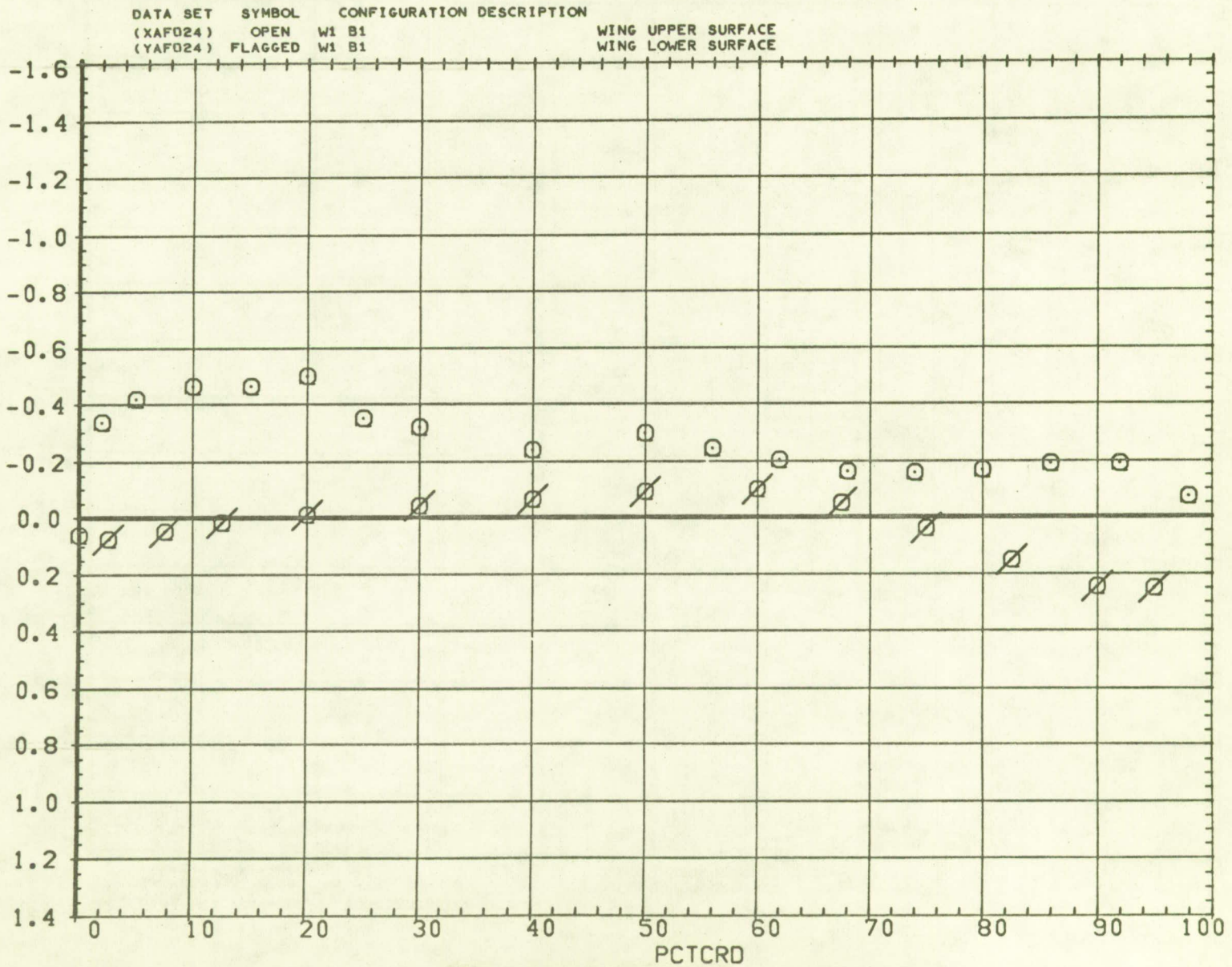

FIG. 19 WING PRESSURE DISTRIBUTION FOR BASIC WING-BODY

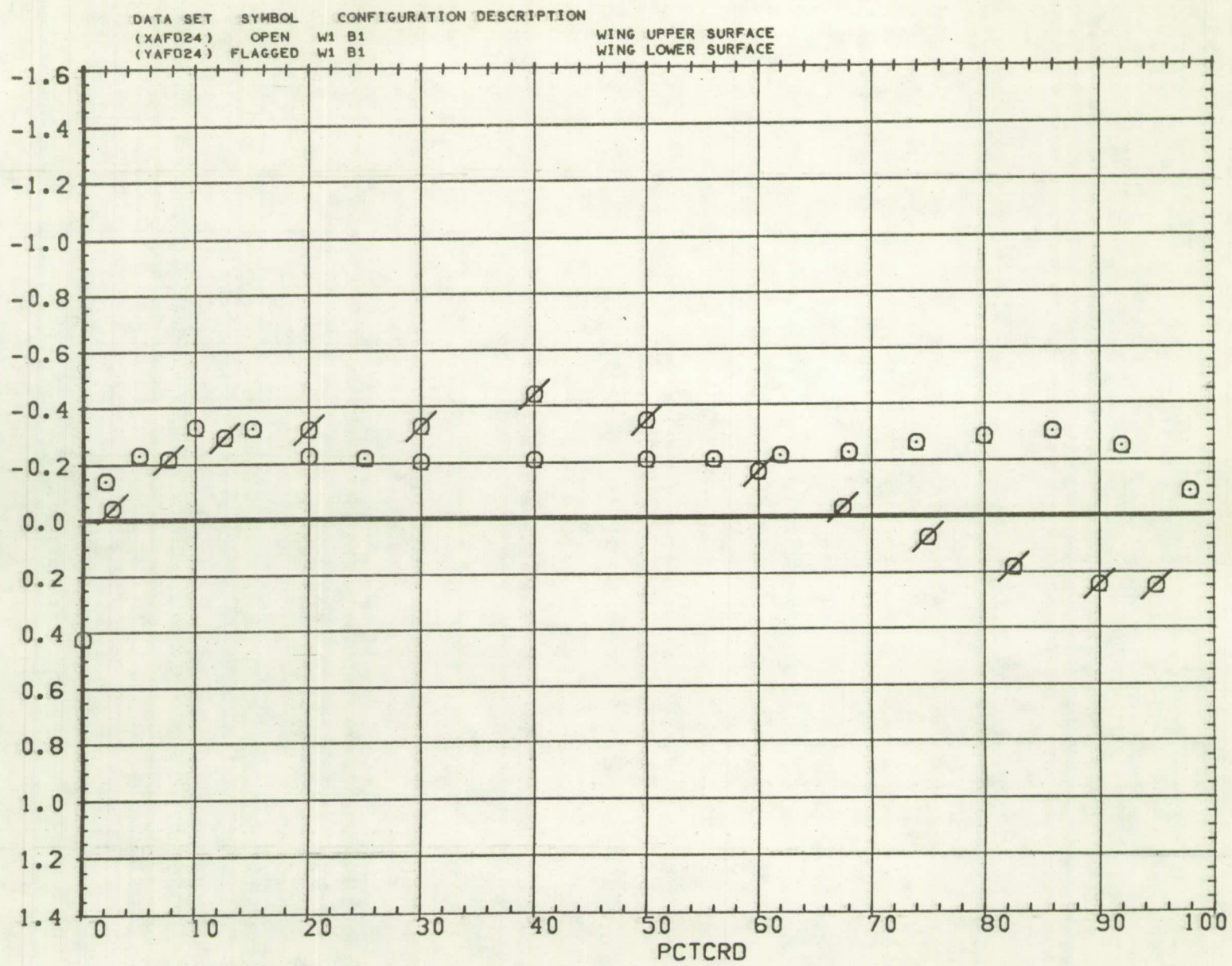

FIG. 19 WING PRESSURE DISTRIBUTION FOR BASIC WING-BODY

SYMBOL ALPHA BL MACH
 ○ 3.550 7.768 0.902

PARAMETRIC VALUES
 BETA 0.000 SPLR-L 0.000
 TRANS 1.000 RN/L 4.000

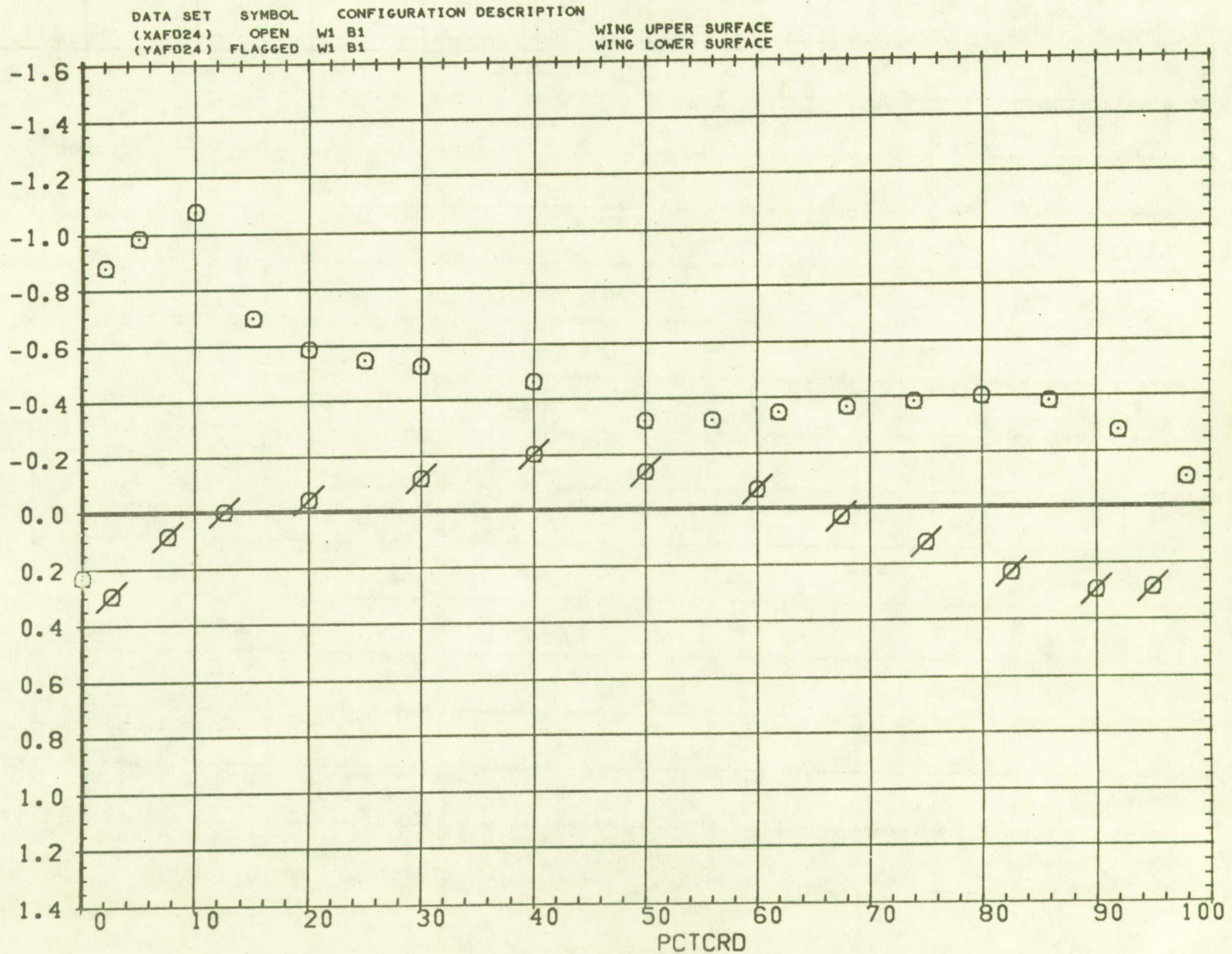

FIG. 19 WING PRESSURE DISTRIBUTION FOR BASIC WING-BODY

SYMBOL	ALPHA	BL	MACH
○	0.000	11.424	0.902

PARAMETRIC VALUES			
BETA	0.000	SPLR-L	0.000
TRANS	1.000	RN/L	4.000

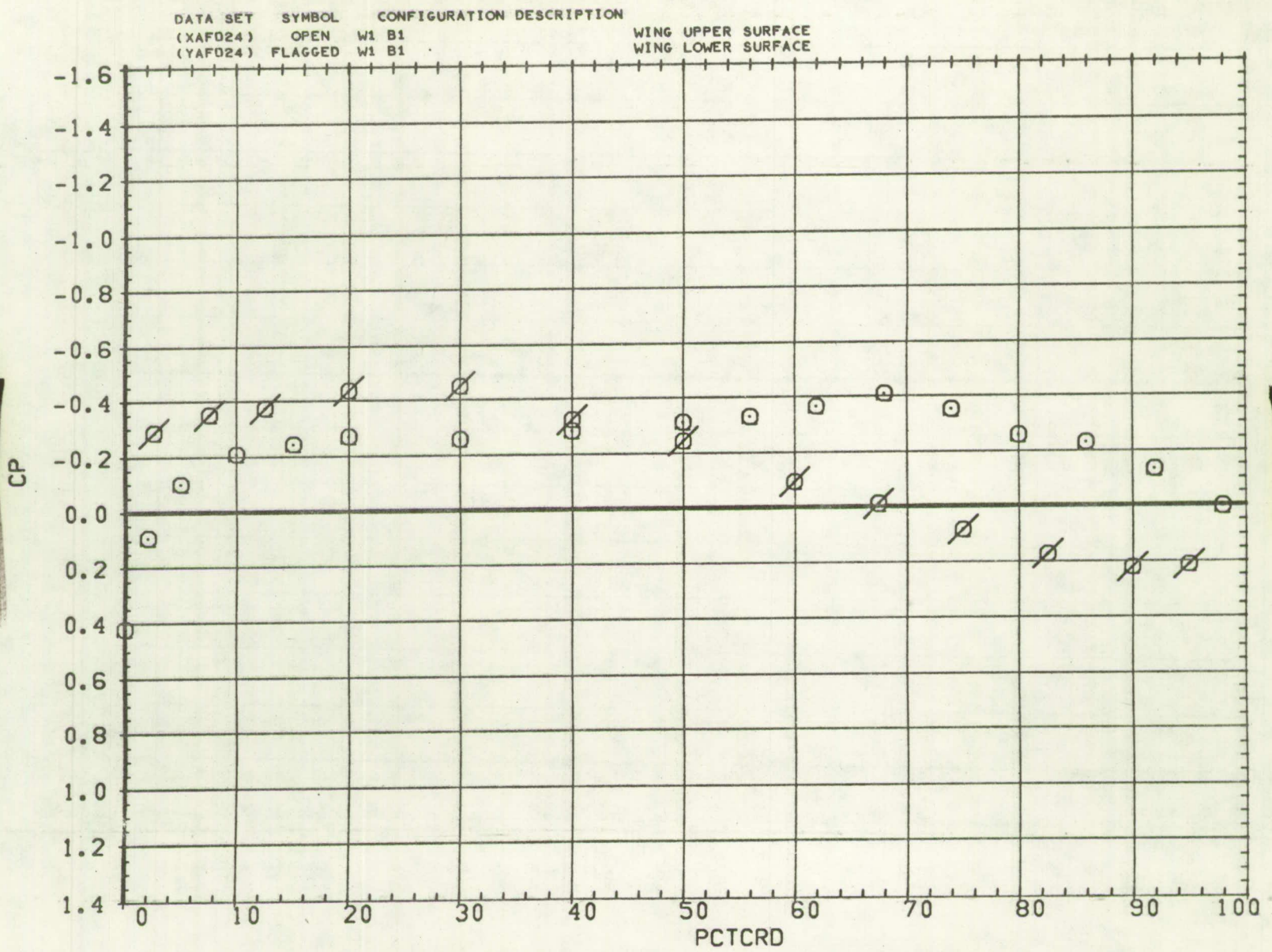

FIG. 19 WING PRESSURE DISTRIBUTION FOR BASIC WING-BODY

SYMBOL ALPHA BL MACH
 ○ 3.550 11.424 0.902

PARAMETRIC VALUES
 BETA 0.000 SPLR-L 0.000
 TRANS 1.000 RN/L 4.000

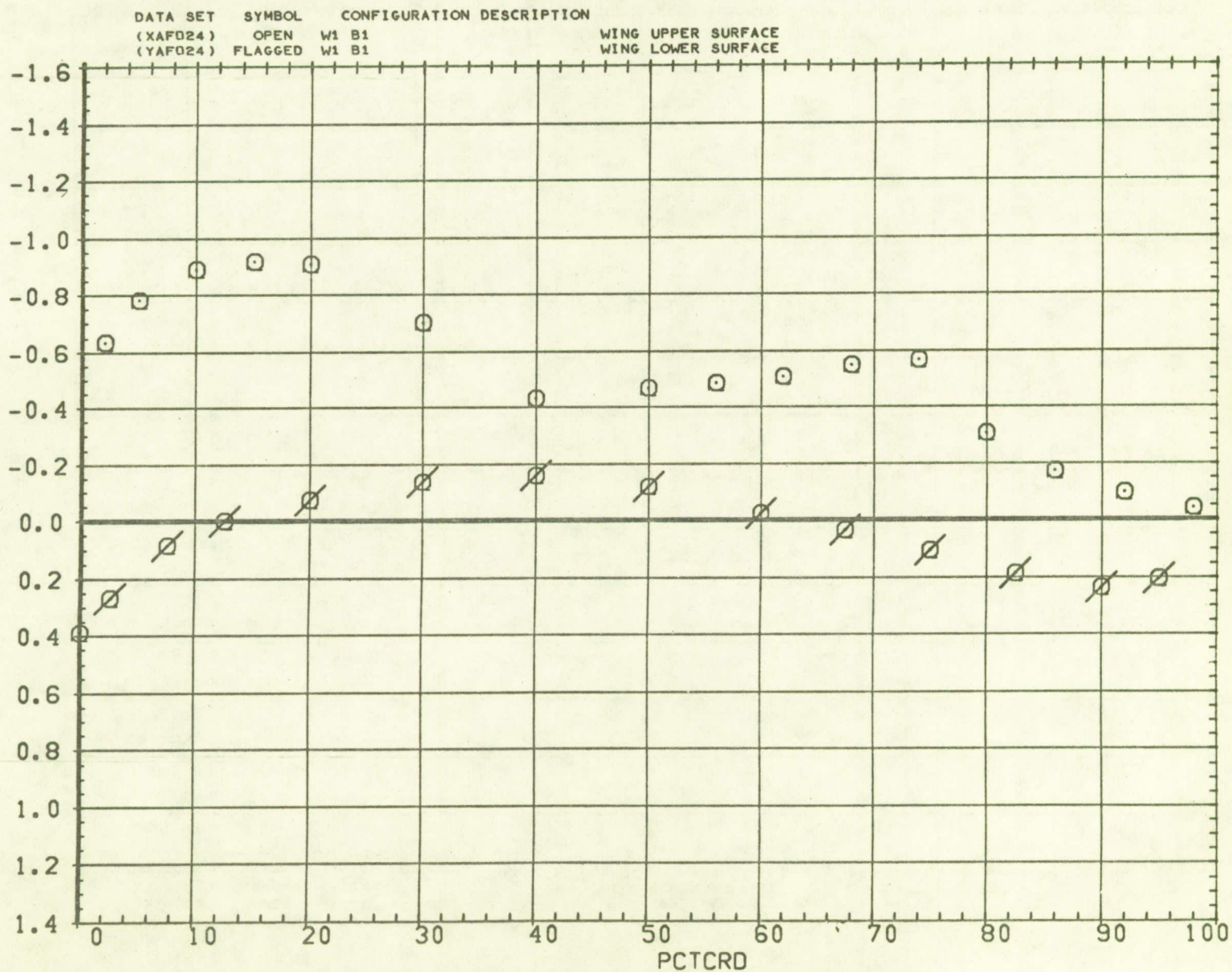

FIG. 19 WING PRESSURE DISTRIBUTION FOR BASIC WING-BODY

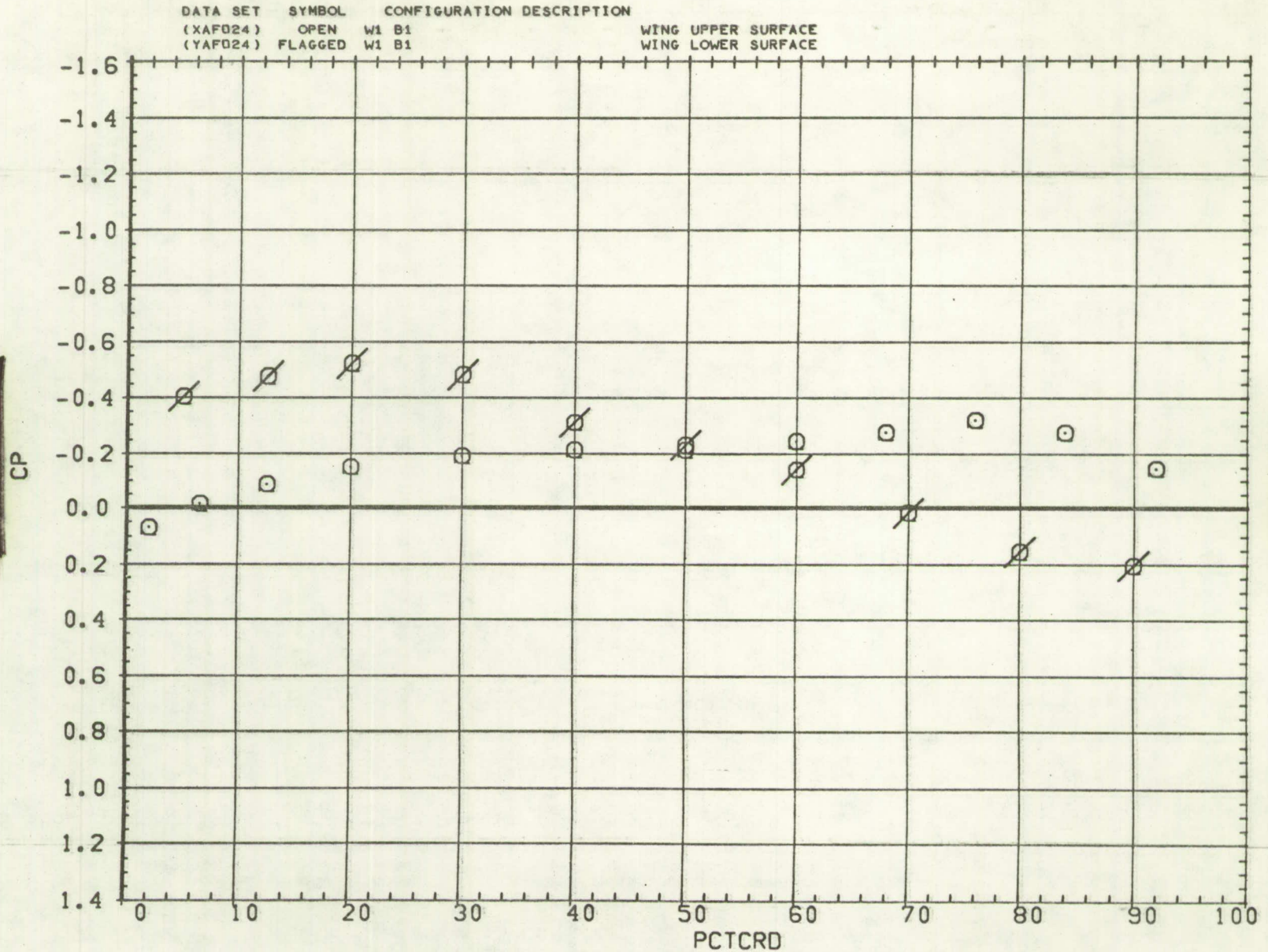

FIG. 19 WING PRESSURE DISTRIBUTION FOR BASIC WING-BODY

SYMBOL ALPHA BL MACH
 ○ 3.550 18.278 0.902

PARAMETRIC VALUES
 BETA 0.000 SPLR-L 0.000
 TRANS 1.000 RN/L 4.000

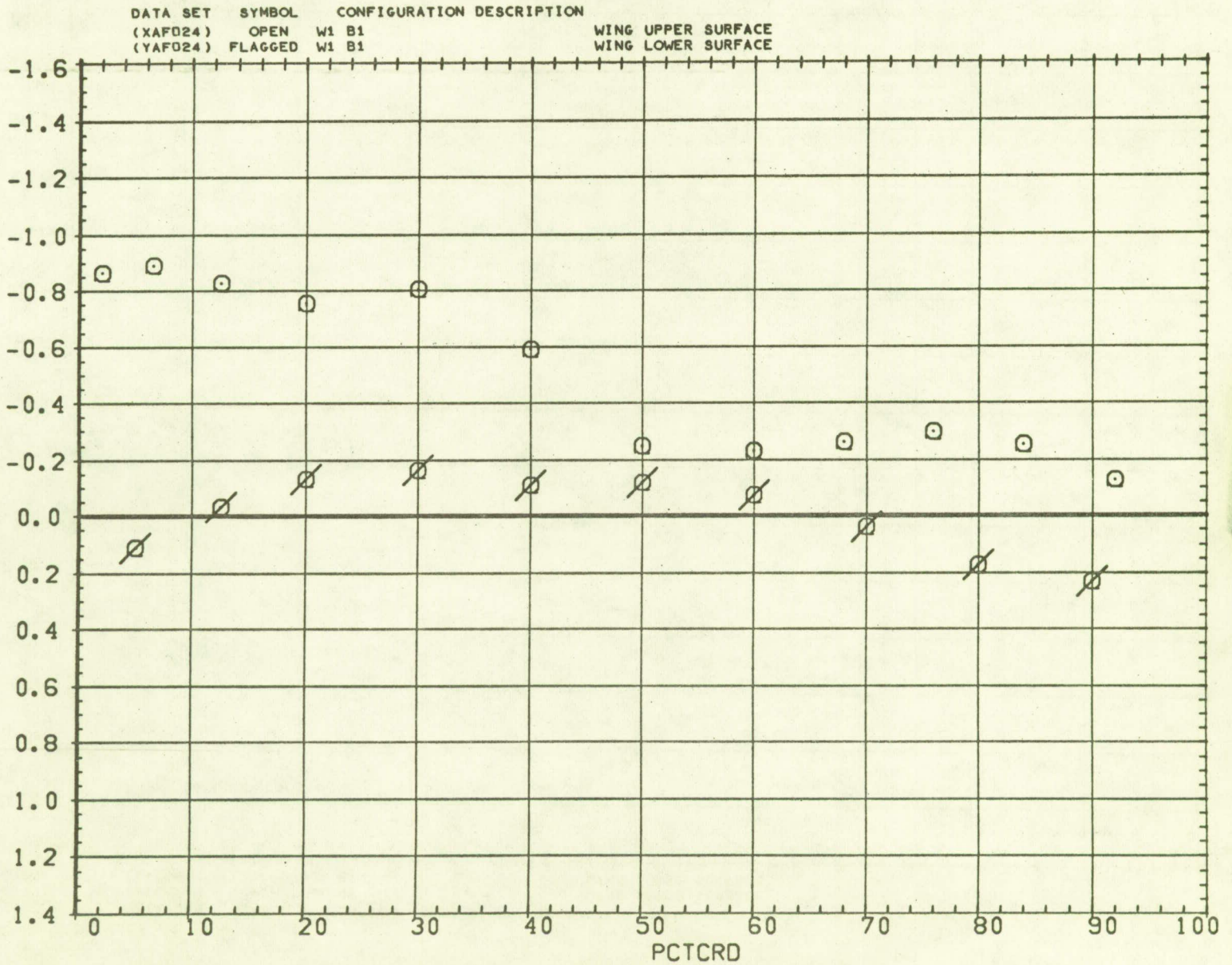

FIG. 19 WING PRESSURE DISTRIBUTION FOR BASIC WING-BODY

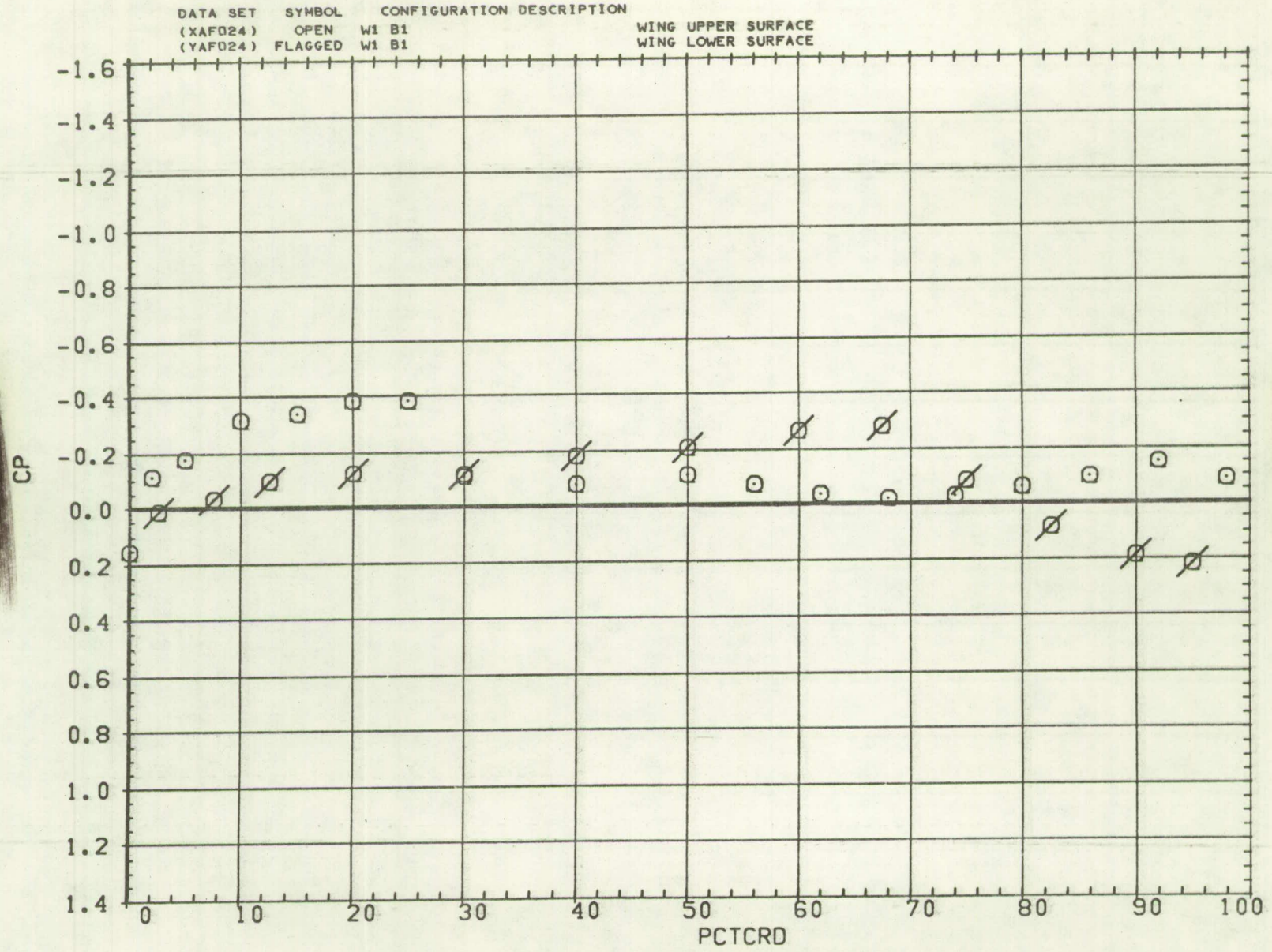

FIG. 19 WING PRESSURE DISTRIBUTION FOR BASIC WING-BODY

SYMBOL ALPHA BL MACH
 ○ 3.510 4.250 0.952

PARAMETRIC VALUES
 BETA 0.000 SPLR-L 0.000
 TRANS 1.000 RN/L 4.000

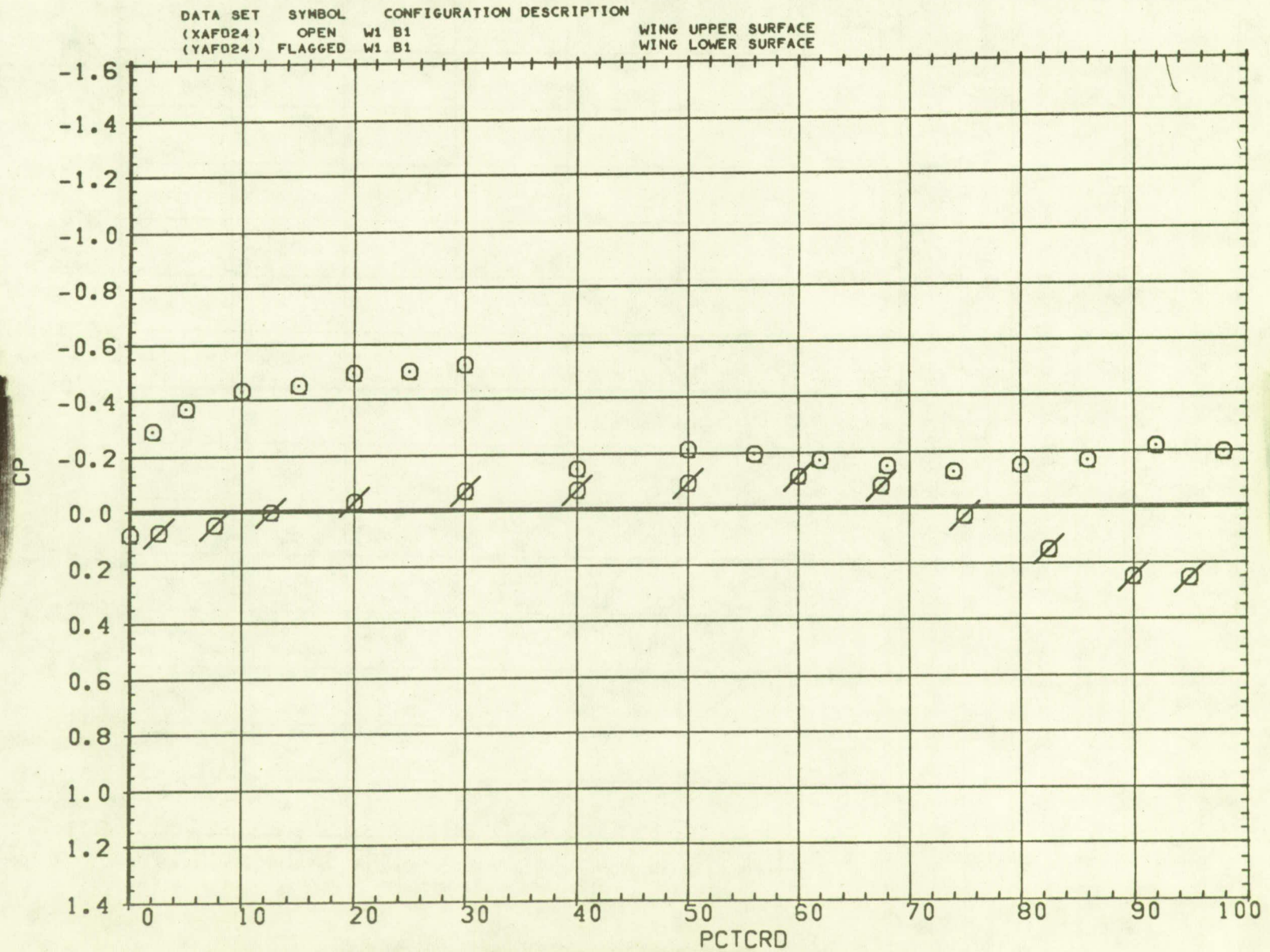

FIG. 19 WING PRESSURE DISTRIBUTION FOR BASIC WING-BODY

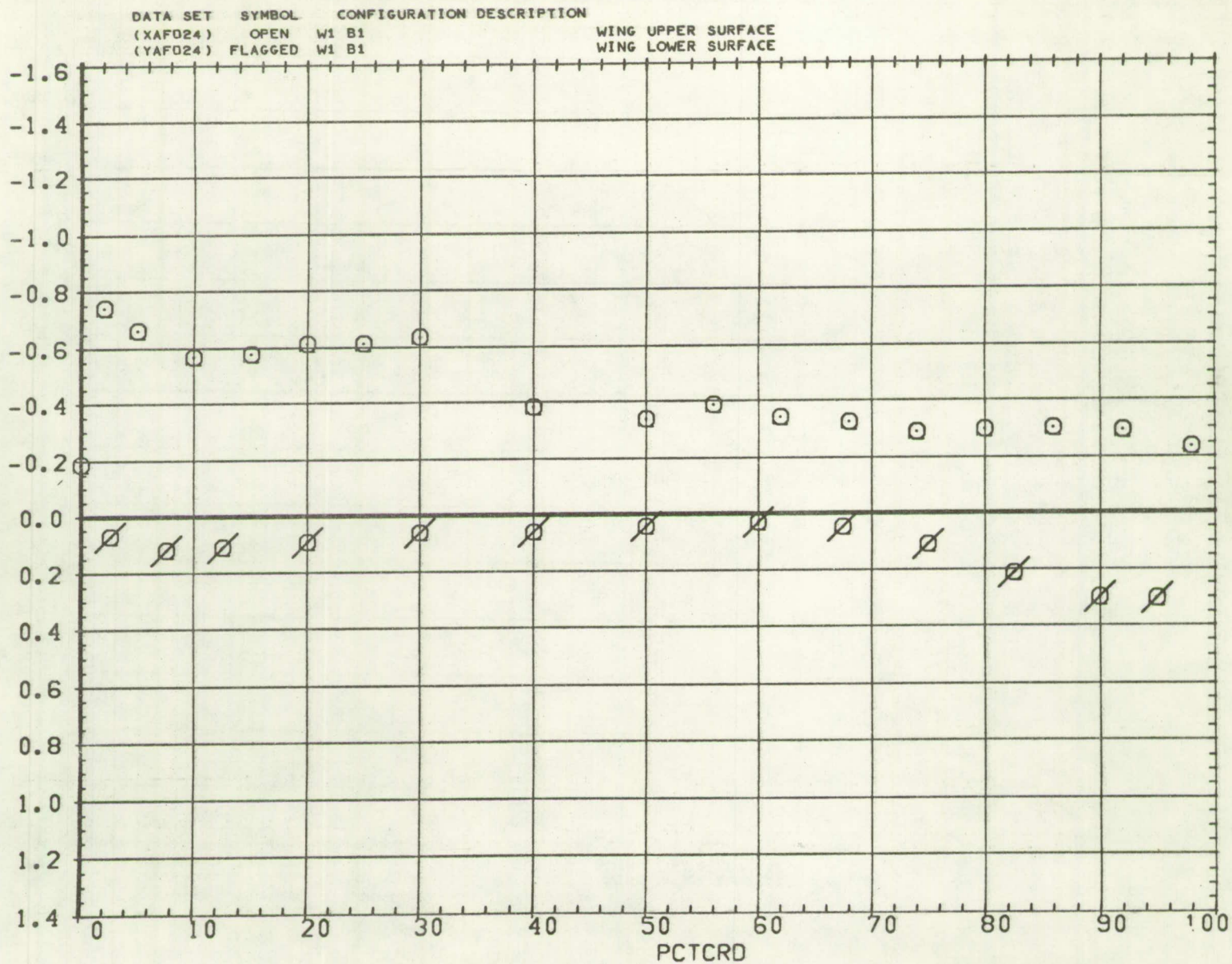

FIG. 19 WING PRESSURE DISTRIBUTION FOR BASIC WING-BODY

SYMBOL ALPHA BL MACH
 ○ - 0.040 7.768 0.952

PARAMETRIC VALUES
 BETA 0.000 SPLR-L 0.000
 TRANS 1.000 RN/L 4.000

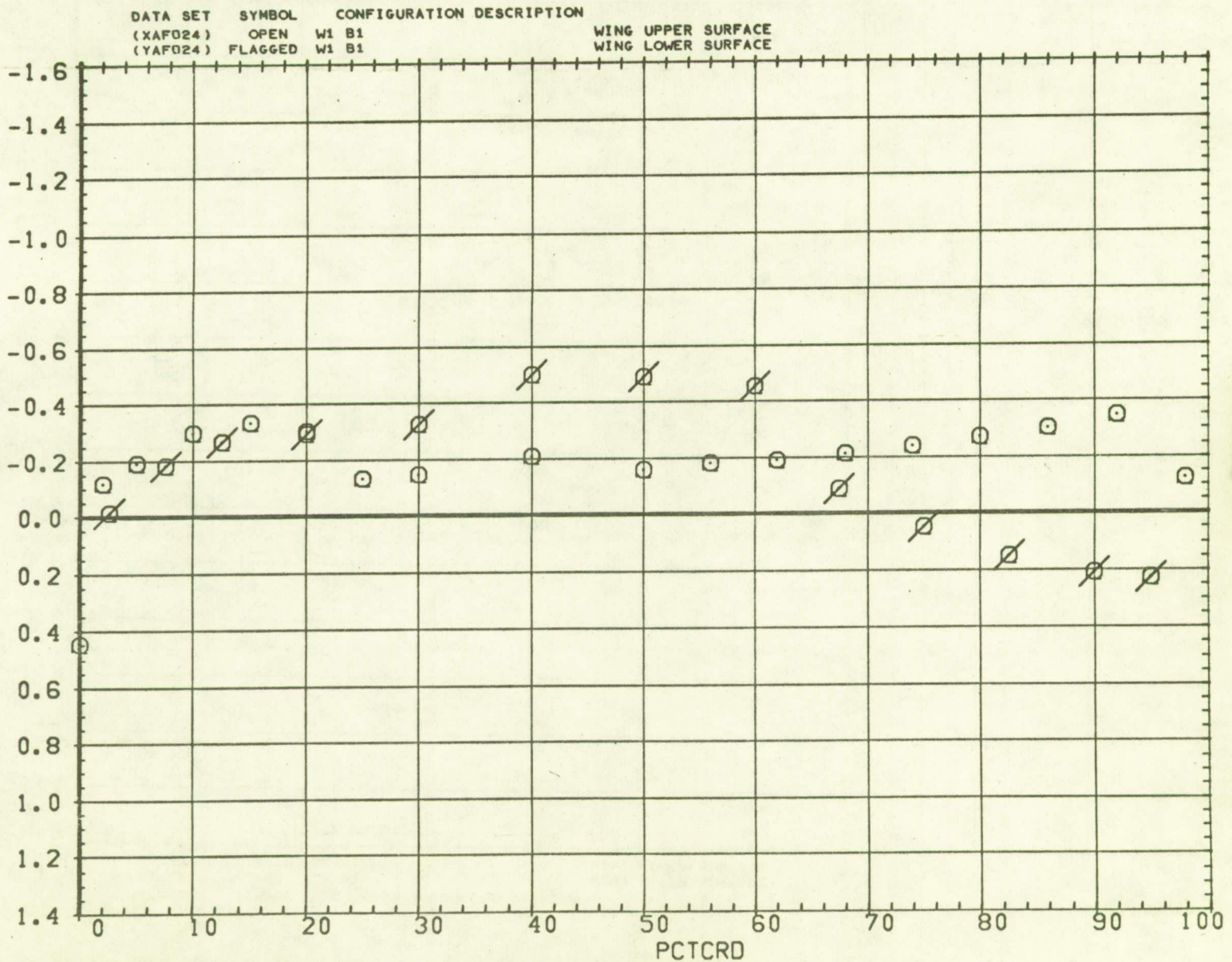

FIG. 19 WING PRESSURE DISTRIBUTION FOR BASIC WING-BODY

SYMBOL	ALPHA	BL	MACH
○	3.510	7.768	0.952

PARAMETRIC VALUES			
BETA	0.000	SPLR-L	0.000
TRANS	1.000	RN/L	4.000

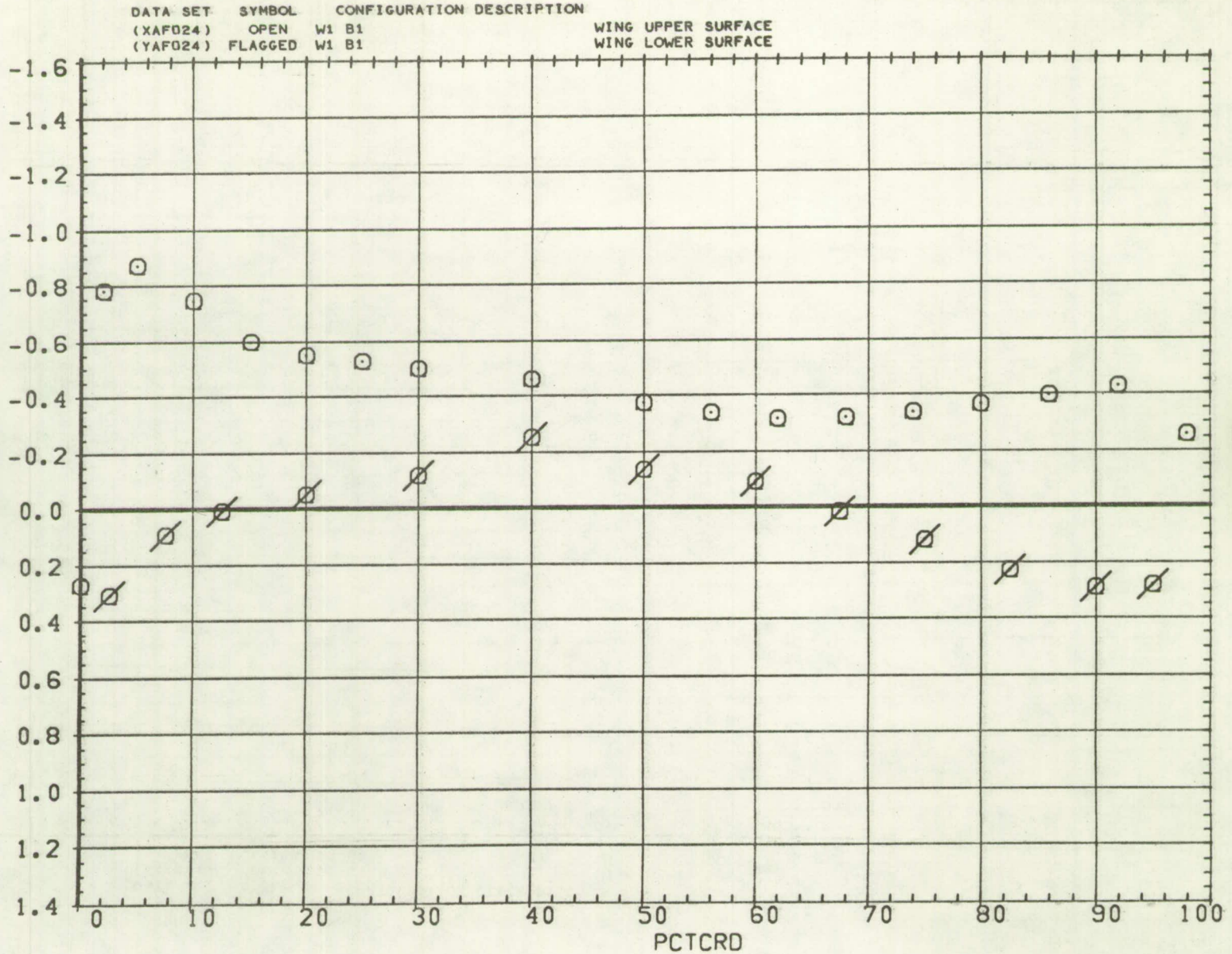

FIG. 19 WING PRESSURE DISTRIBUTION FOR BASIC WING-BODY

SYMBOL ALPHA BL MACH
 ○ 7.980 7.768 0.952

PARAMETRIC VALUES
 BETA 0.000 SPLR-L 0.000
 TRANS 1.000 RN/L 4.000

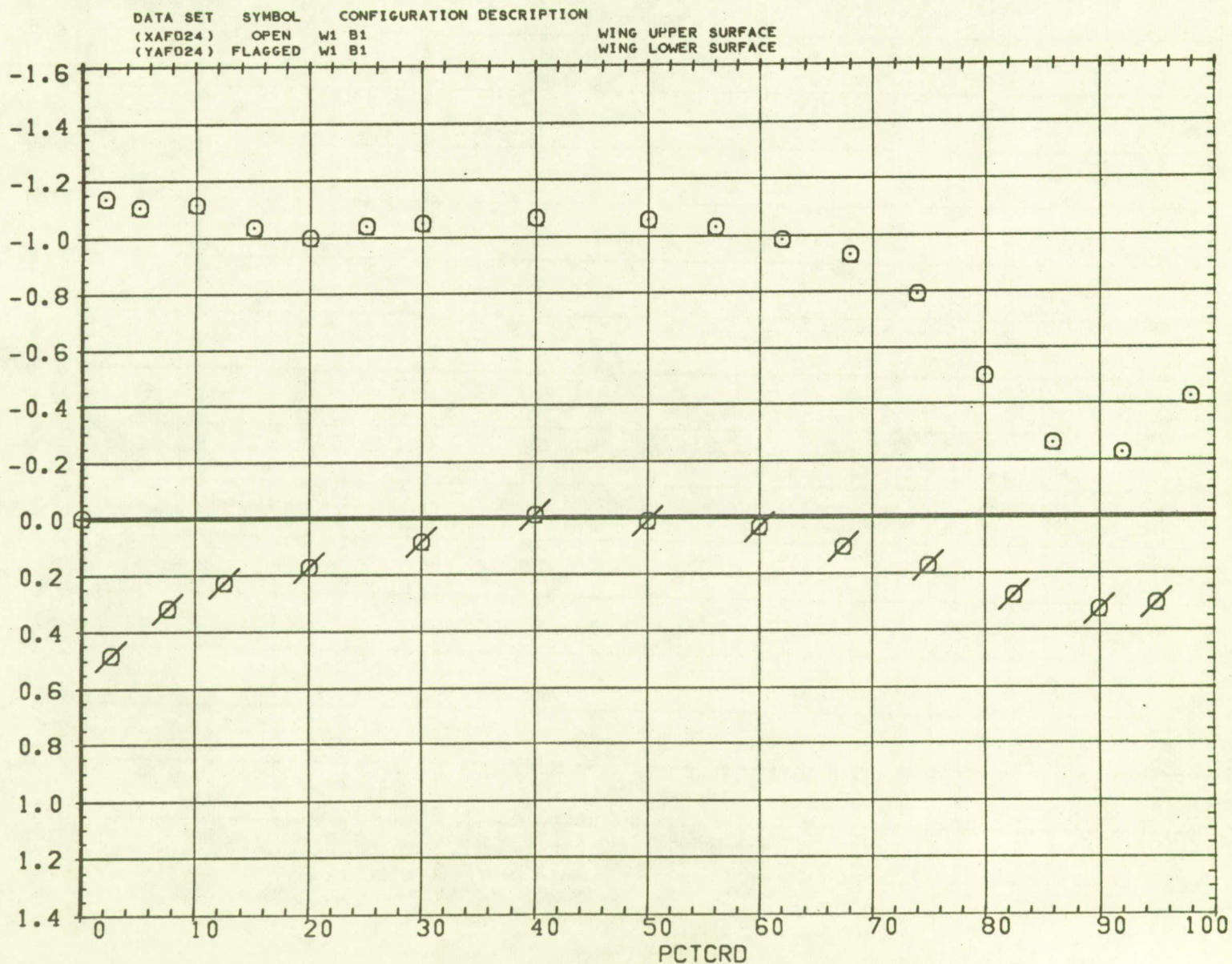

FIG. 19 WING PRESSURE DISTRIBUTION FOR BASIC WING-BODY

SYMBOL ALPHA BL MACH
 ○ - 0.040 11.424 0.952

PARAMETRIC VALUES
 BETA 0.000 SPLR-L 0.000
 TRANS 1.000 RN/L 4.000

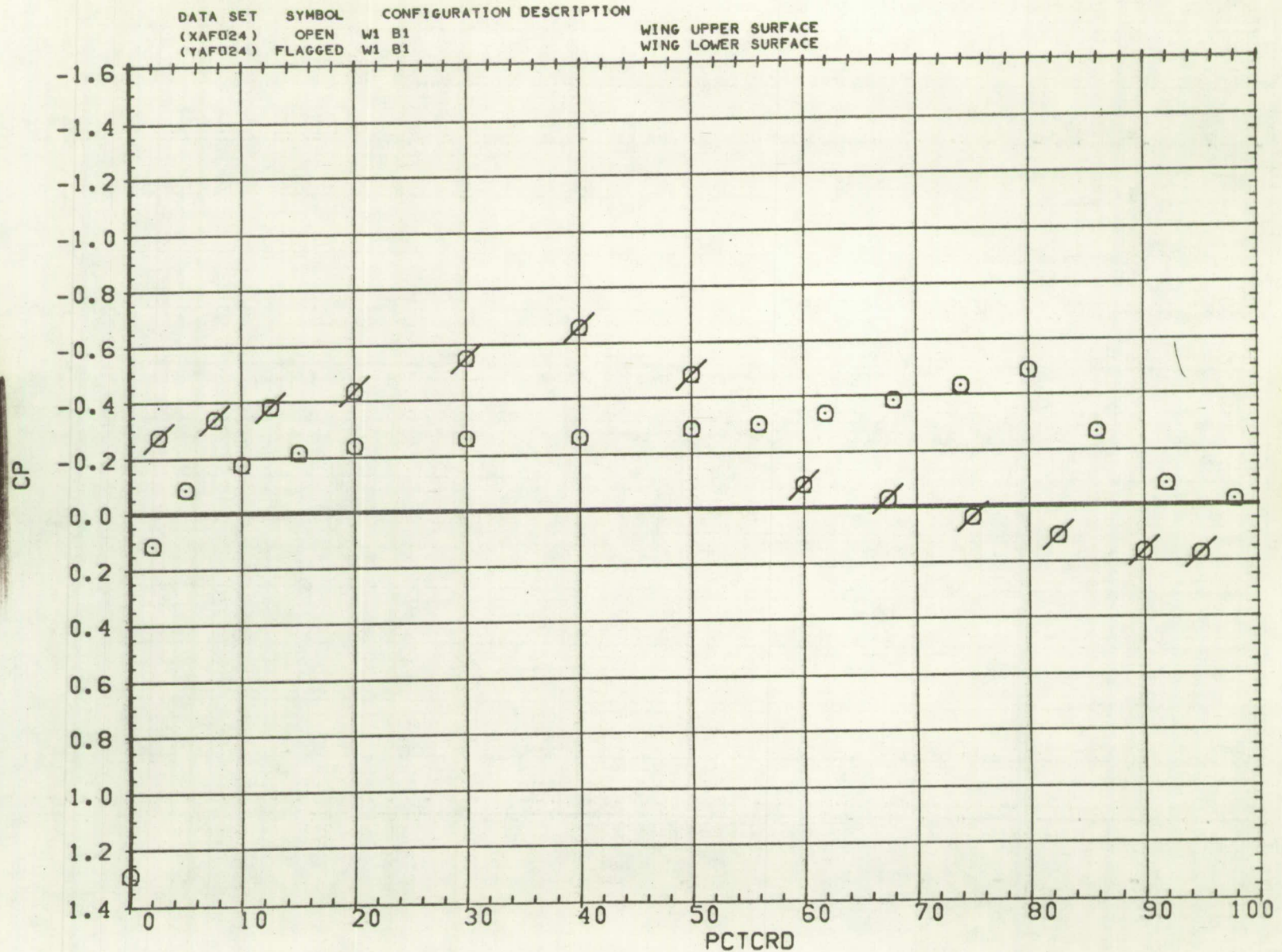

FIG. 19 WING PRESSURE DISTRIBUTION FOR BASIC WING-BODY

SYMBOL	ALPHA	BL	MACH
○	3.510	11.424	0.952

PARAMETRIC VALUES			
BETA	0.000	SPLR-L	0.000
TRANS	1.000	RN/L	4.000

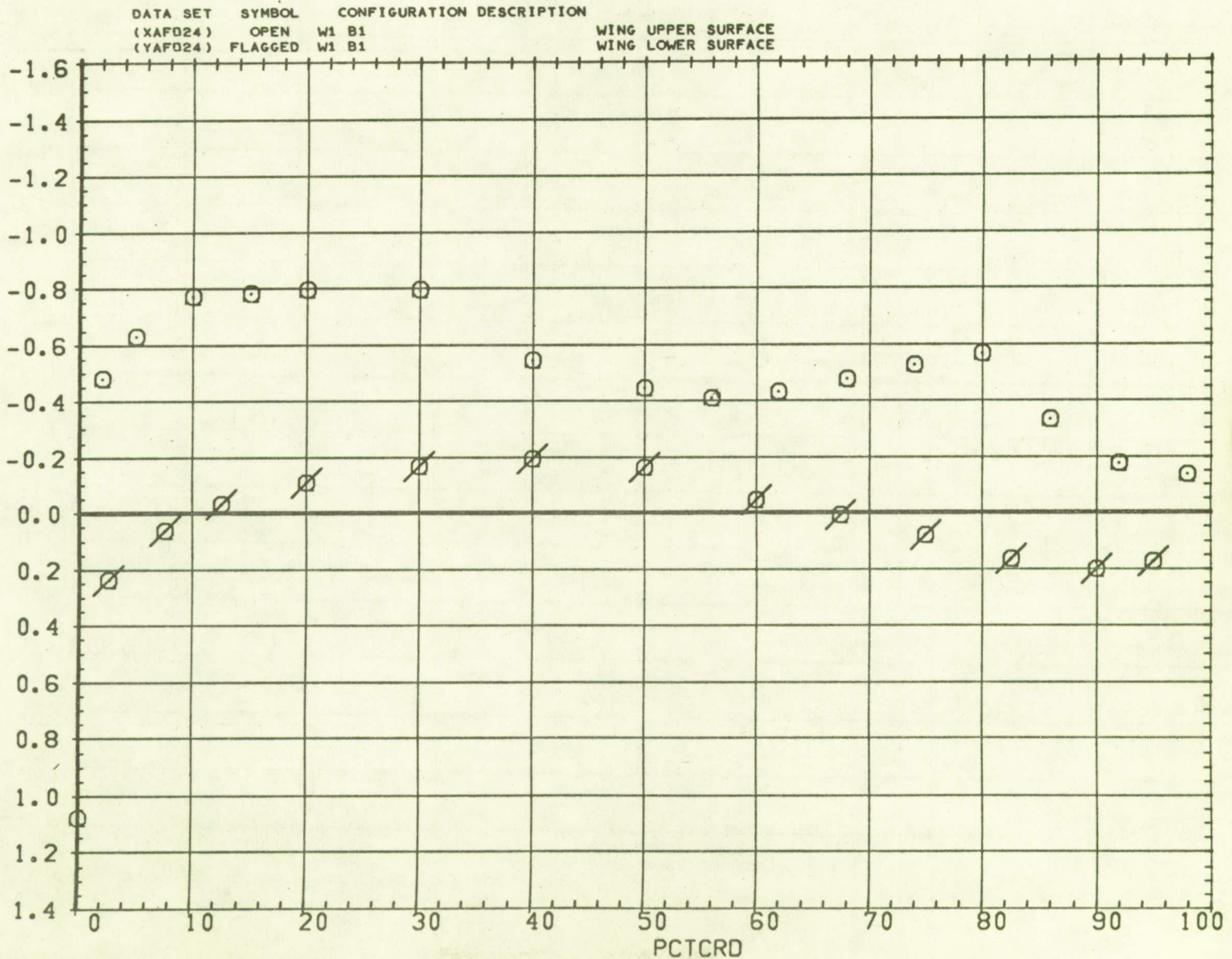

FIG. 19 WING PRESSURE DISTRIBUTION FOR BASIC WING-BODY

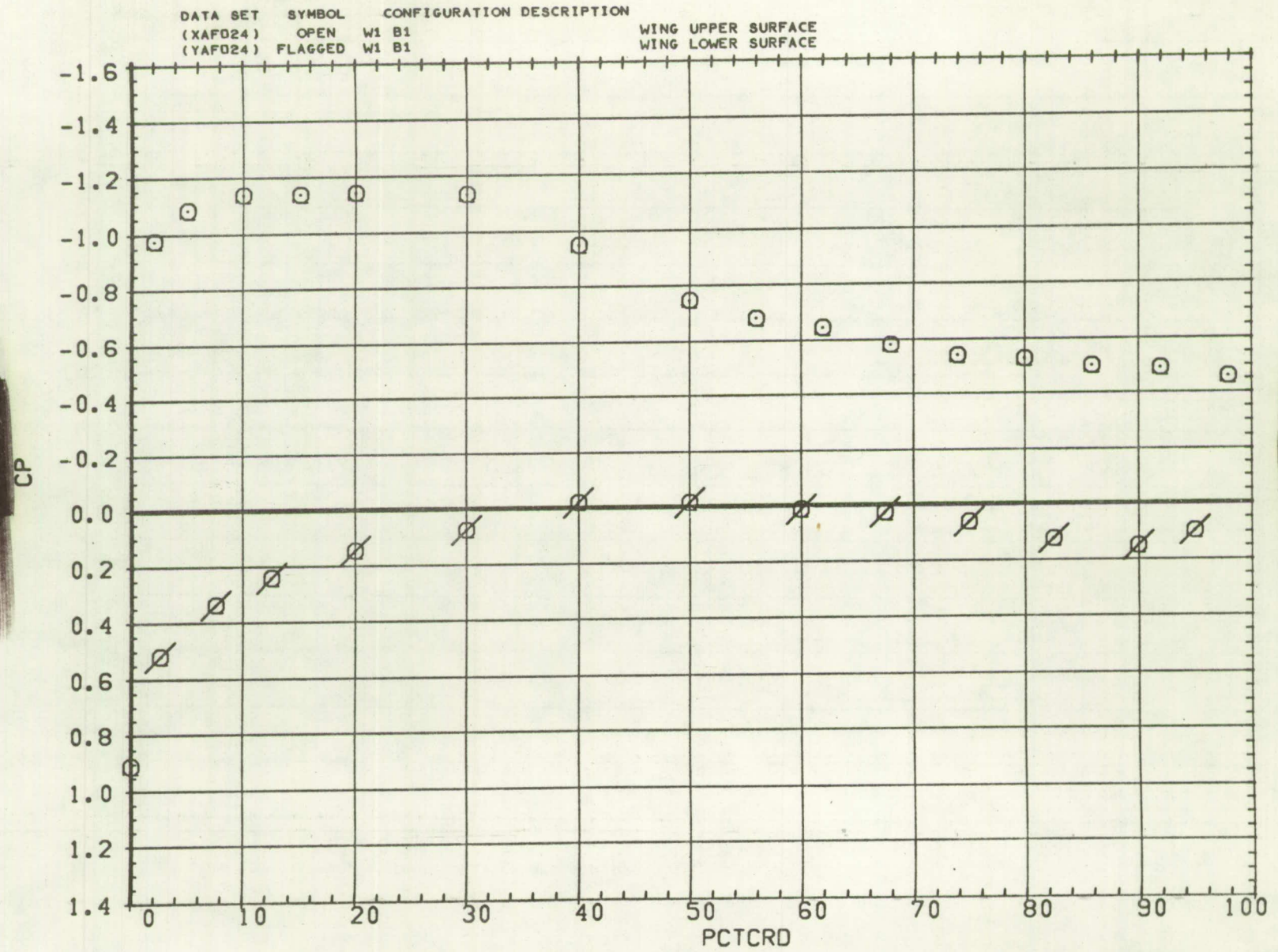

FIG. 19 WING PRESSURE DISTRIBUTION FOR BASIC WING-BODY

SYMBOL ALPHA BL MACH
 ○ - 0.040 18.278 0.952

PARAMETRIC VALUES
 BETA 0.000 SPLR-L 0.000
 TRANS 1.000 RN/L 4.000

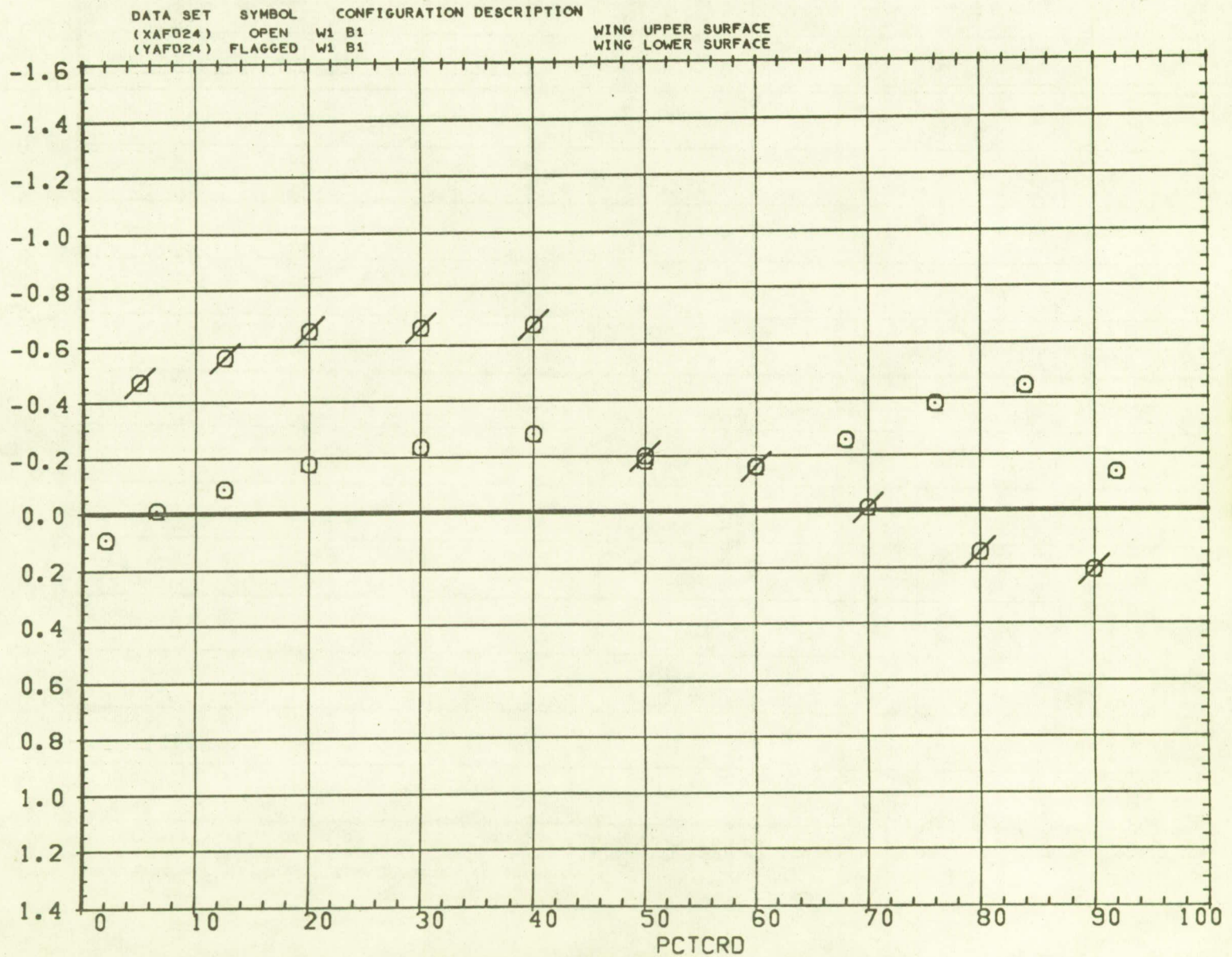

FIG. 19 WING PRESSURE DISTRIBUTION FOR BASIC WING-BODY

SYMBOL ALPHA BL MACH
 ○ 3.510 18.278 0.952

PARAMETRIC VALUES
 BETA 0.000 SPLR-L 0.000
 TRANS 1.000 RN/L 4.000

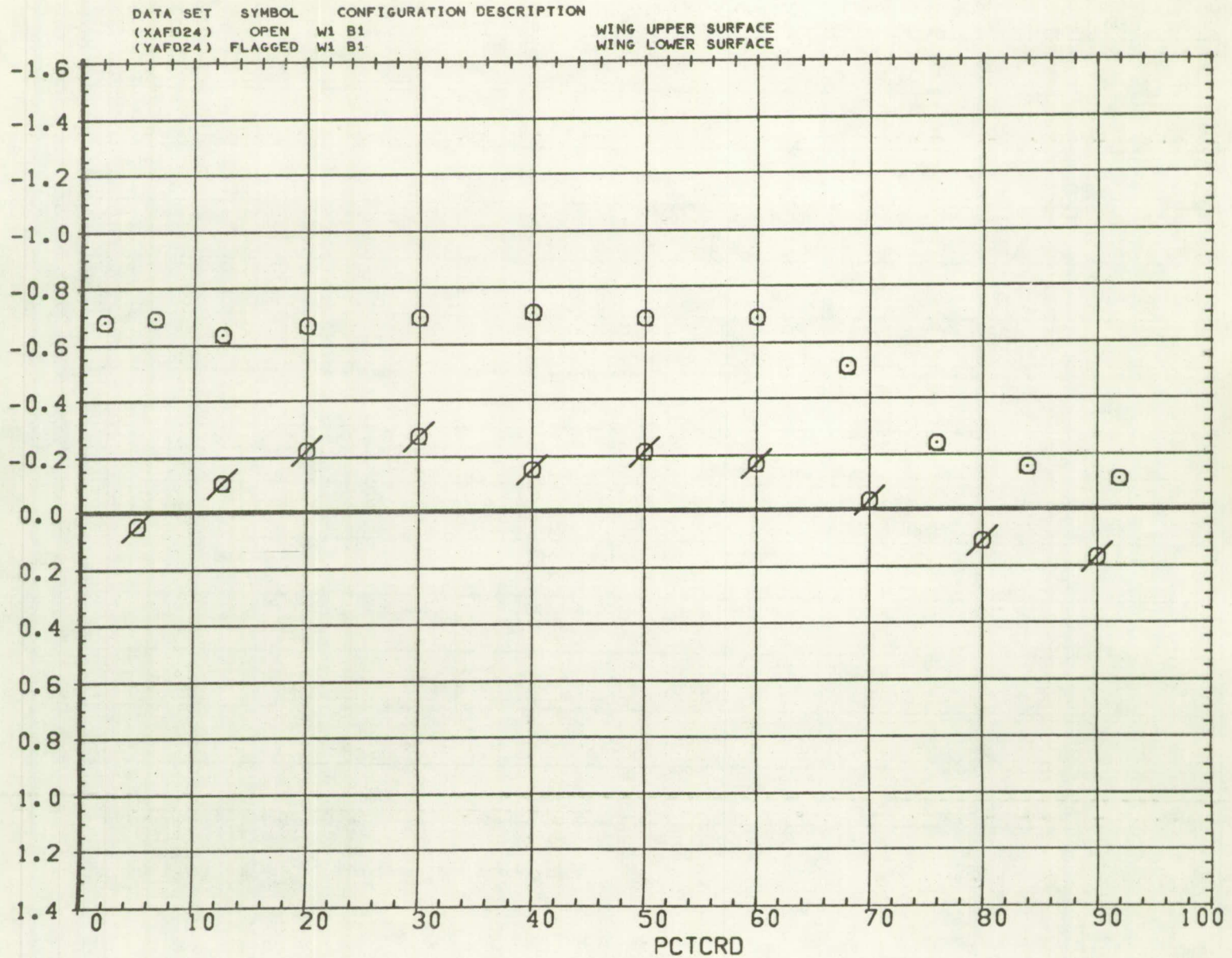

FIG. 19 WING PRESSURE DISTRIBUTION FOR BASIC WING-BODY

SYMBOL	ALPHA	BL	MACH
○	7.980	18.278	0.952

PARAMETRIC VALUES			
BETA	0.000	SPLR-L	0.000
TRANS	1.000	RN/L	4.000

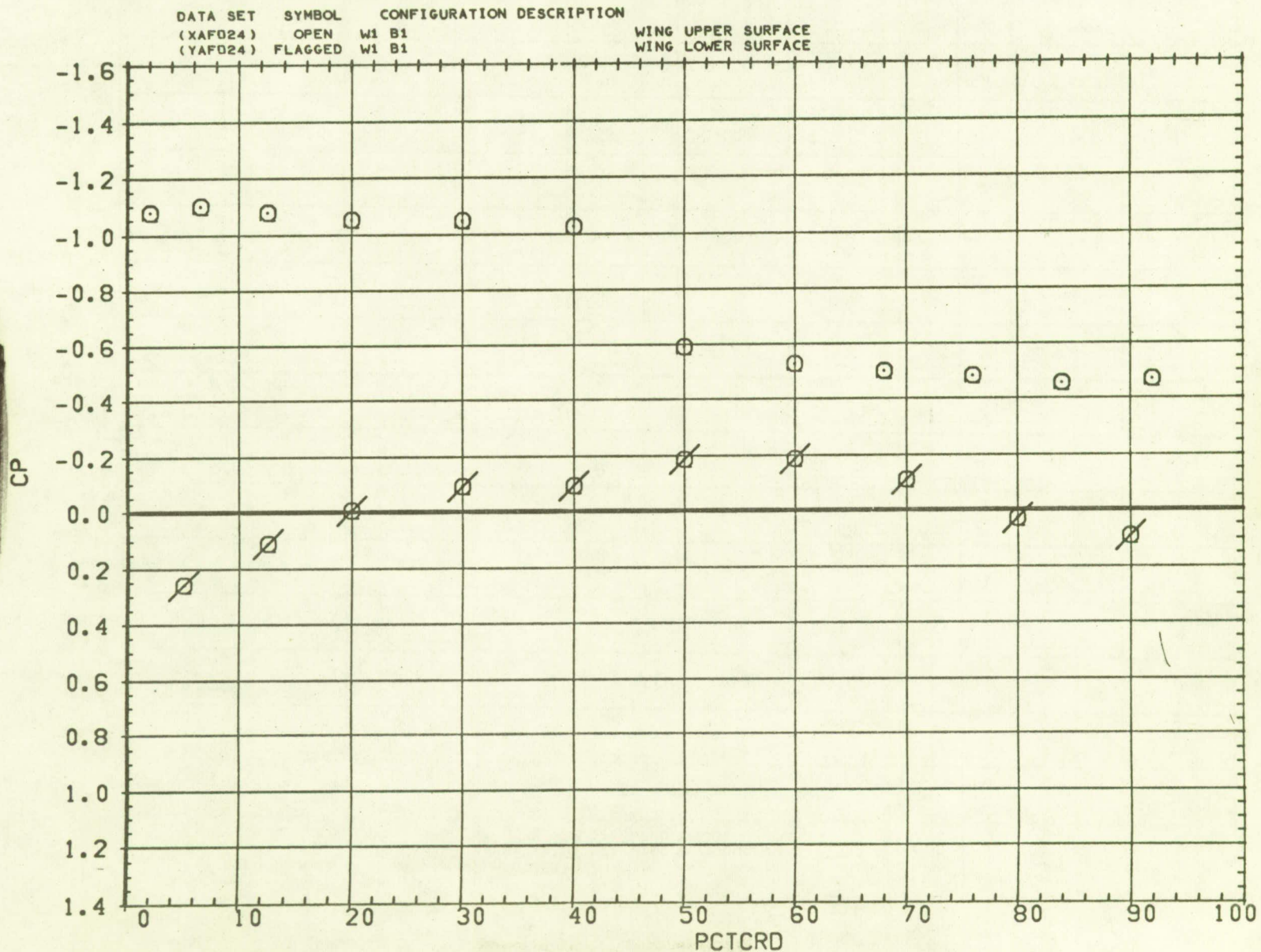

FIG. 19 WING PRESSURE DISTRIBUTION FOR BASIC WING-BODY

SYMBOL ALPHA BL MACH
 O - 0.020 4.250 0.500

PARAMETRIC VALUES
 BETA 0.000 HORIZT - 1.000
 SPLR-L 0.000 TRANS 1.000
 RN/L 4.000

DATA SET SYMBOL CONFIGURATION DESCRIPTION
 (XAF013) OPEN W1 B1 V1 H1 K1 N1 K2 N2 ZF1 WING UPPER SURFACE
 (YAF013) FLAGGED W1 B1 V1 H1 K1 N1 K2 N2 ZF1 WING LOWER SURFACE

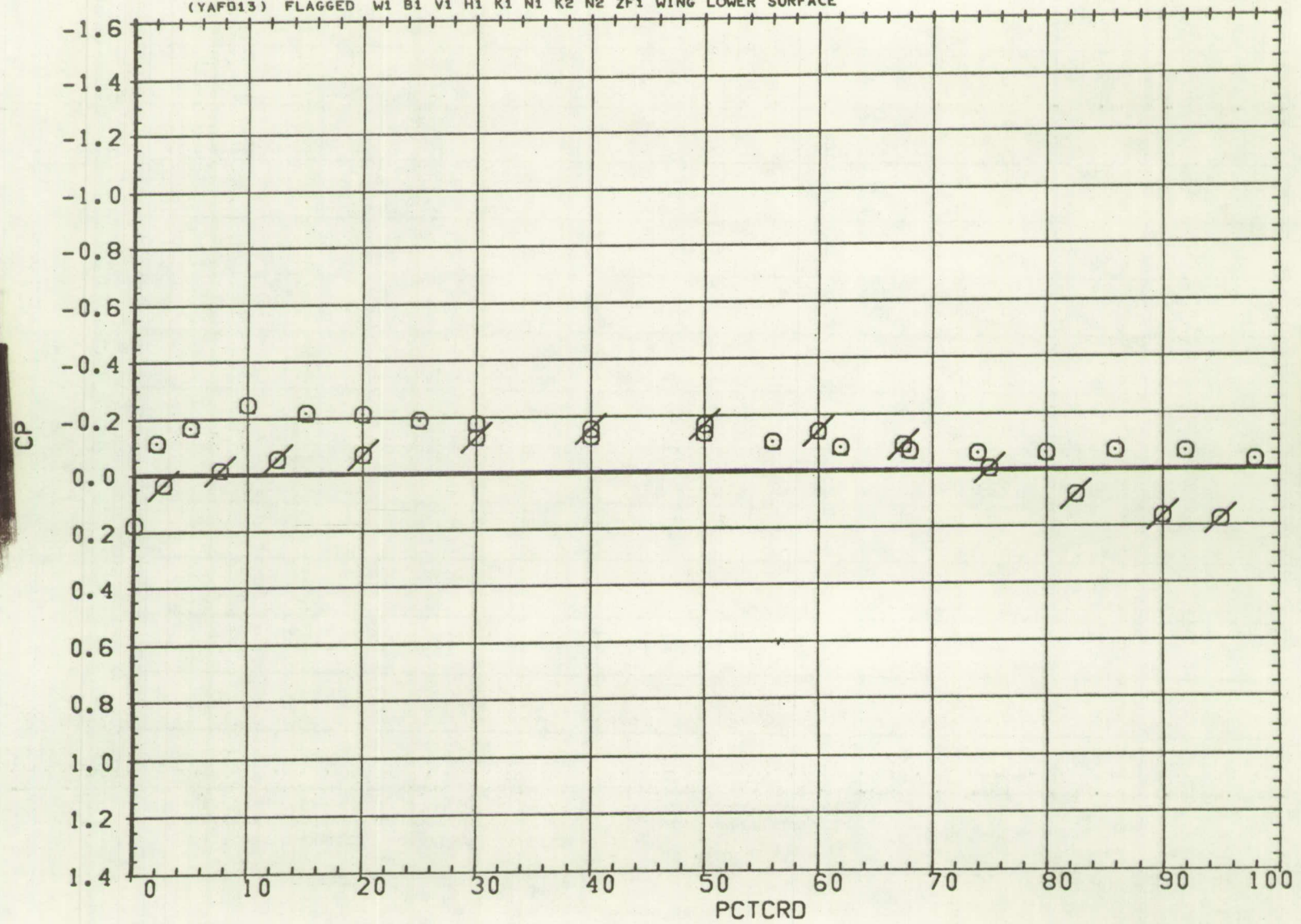

FIG. 20 WING PRESSURE DISTRIBUTION FOR FULL MODEL CONFIGURATION

SYMBOL ALPHA BL MACH
 ○ 3.450 4.250 0.500

PARAMETRIC VALUES
 BETA 0.000 HORIZT - 1.000
 SPLR-L 0.000 TRANS 1.000
 RN/L 4.000

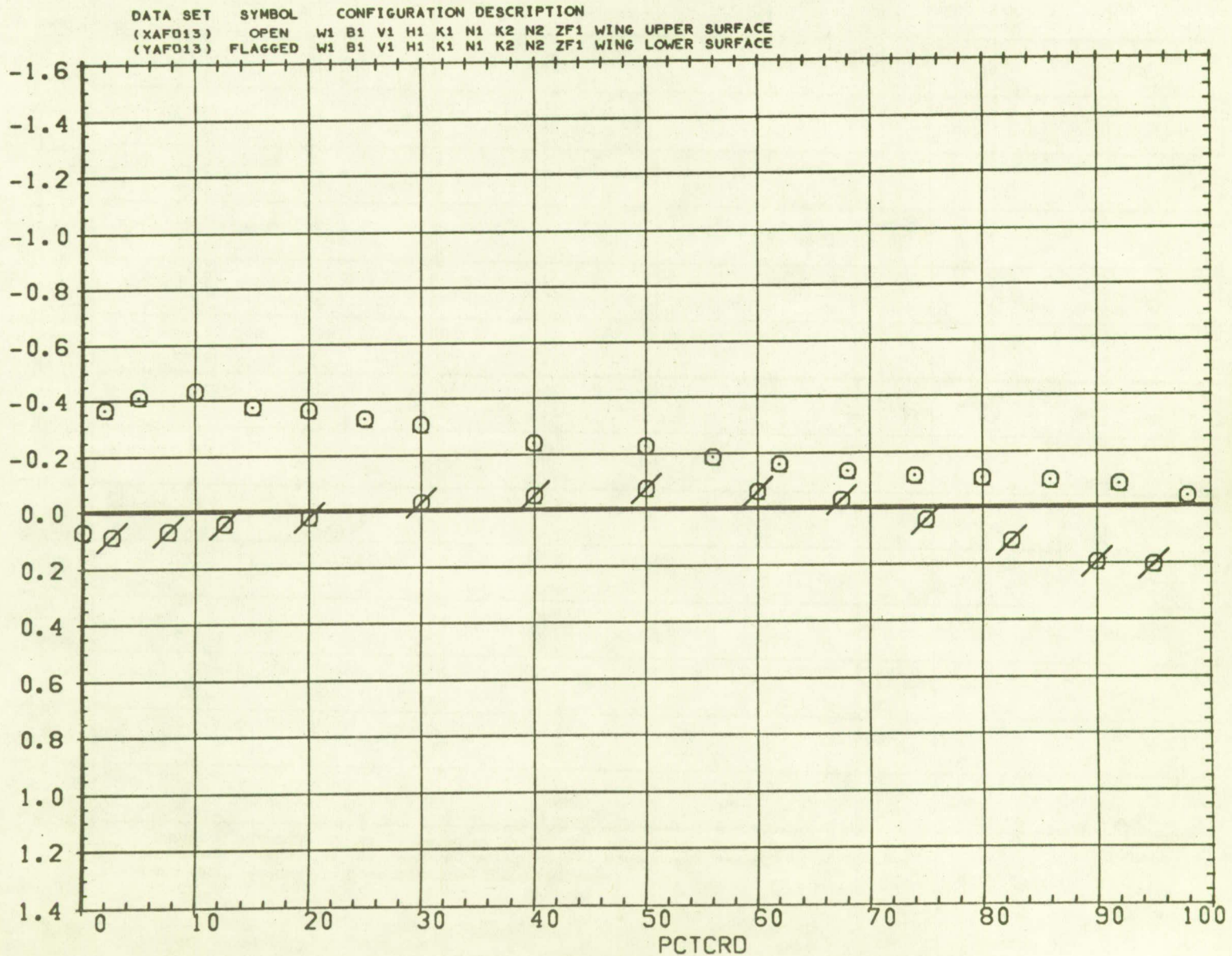

FIG. 20 WING PRESSURE DISTRIBUTION FOR FULL MODEL CONFIGURATION

SYMBOL ALPHA BL MACH
 ○ 4.470 4.250 0.500

PARAMETRIC VALUES
 BETA 0.000 HORIZT - 1.000
 SPLR-L 0.000 TRANS 1.000
 RN/L 4.000

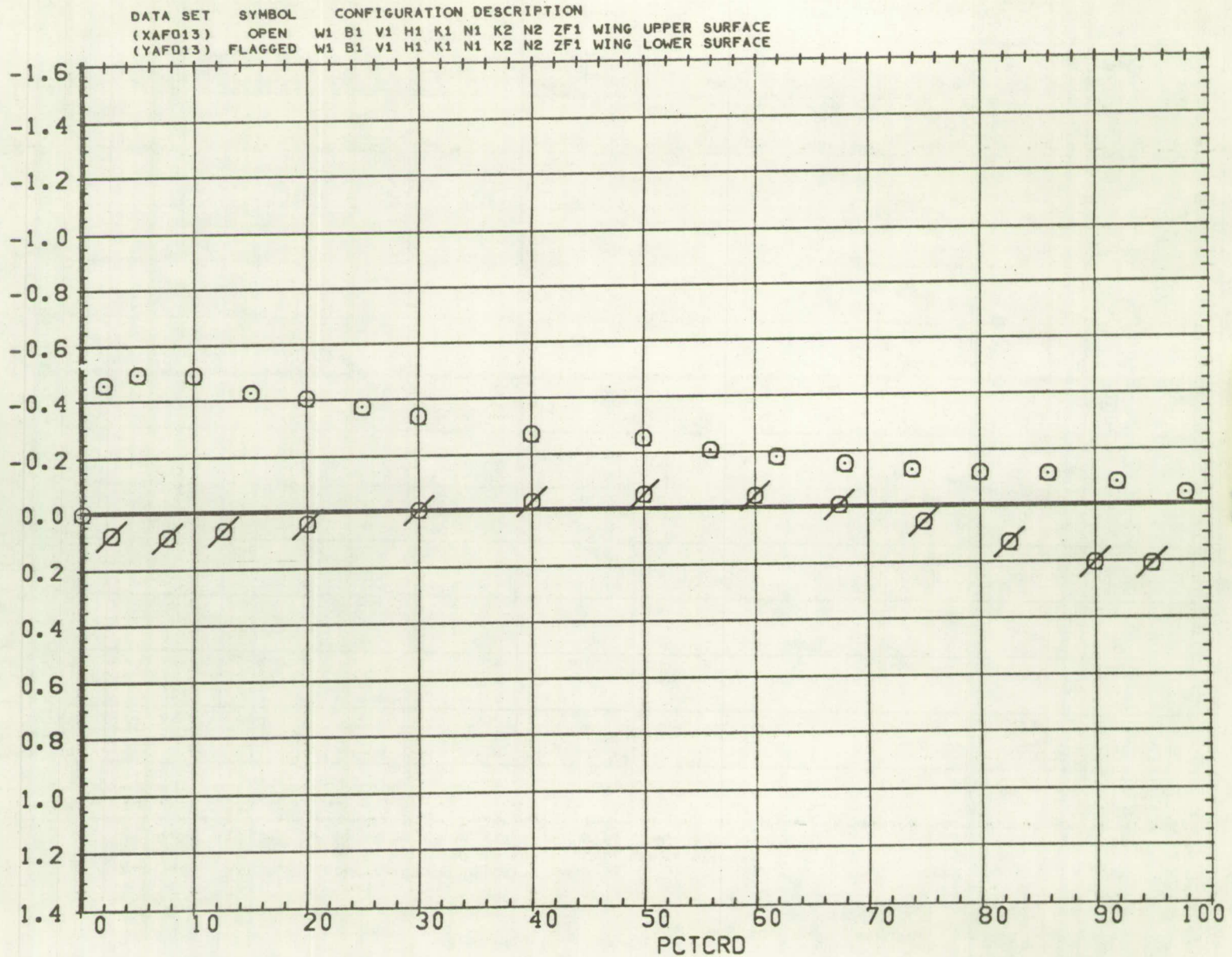

FIG. 20 WING PRESSURE DISTRIBUTION FOR FULL MODEL CONFIGURATION

SYMBOL ALPHA BL MACH
 ○ - 0.020 7.768 0.500

PARAMETRIC VALUES
 BETA 0.000 HORIZT - 1.000
 SPLR-L 0.000 TRANS 1.000
 RN/L 4.000

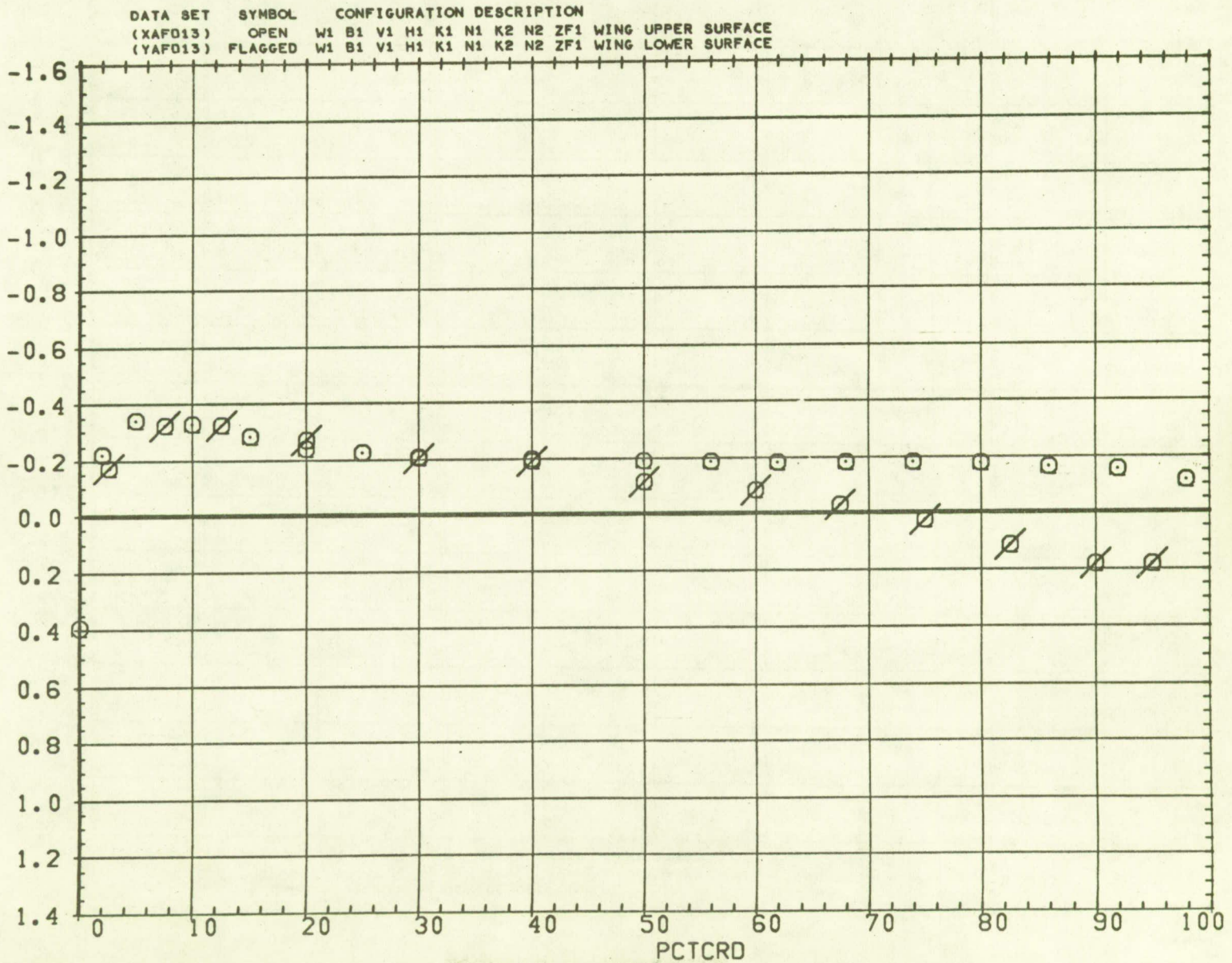

FIG. 20 WING PRESSURE DISTRIBUTION FOR FULL MODEL CONFIGURATION

SYMBOL ALPHA BL MACH
 ○ 3.450 7.768 0.500

PARAMETRIC VALUES
 BETA 0.000 HORIZT -- 1.000
 SPLR-L 0.000 TRANS 1.000
 RN/L 4.000

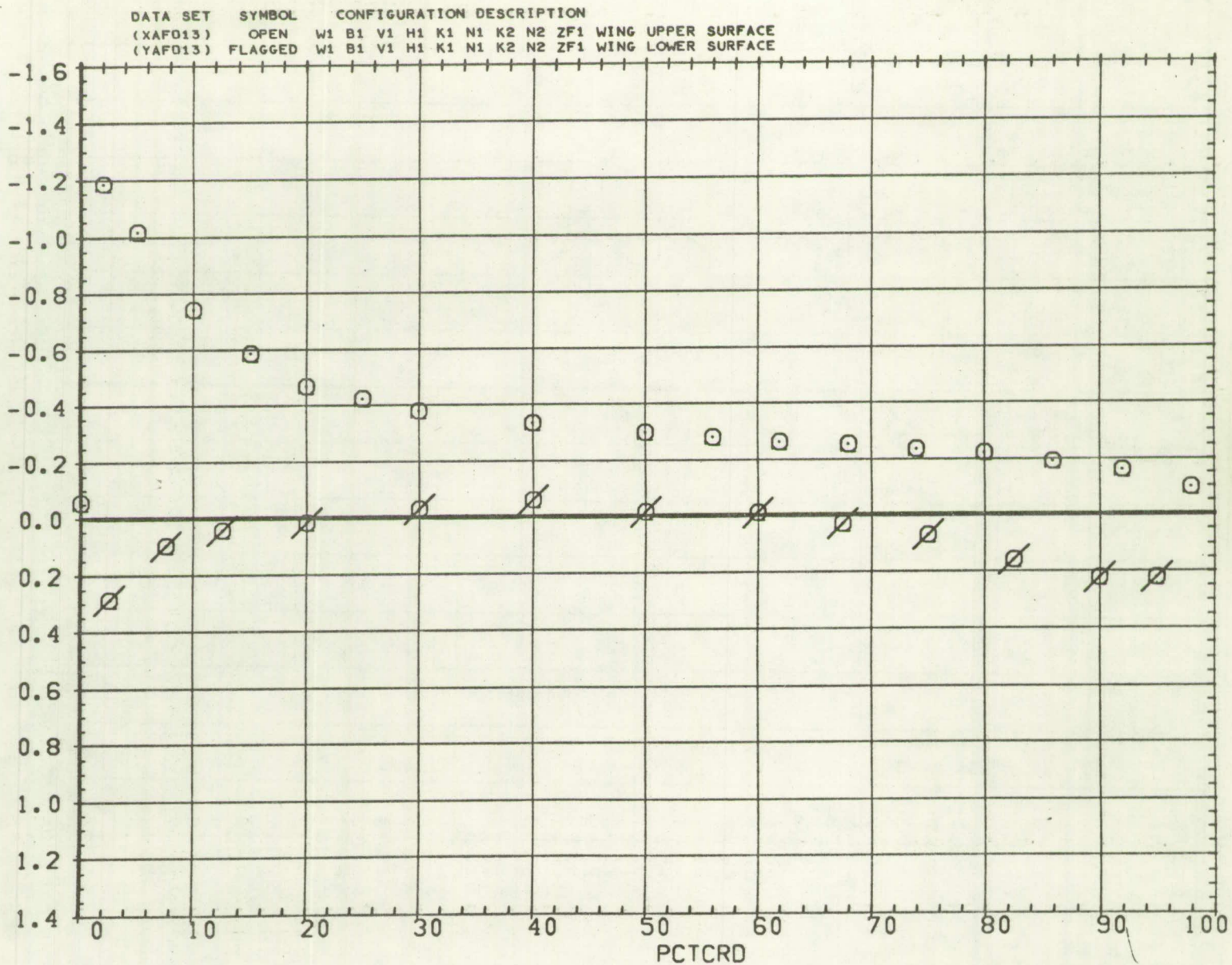

FIG. 20 WING PRESSURE DISTRIBUTION FOR FULL MODEL CONFIGURATION

SYMBOL ALPHA BL MACH
 ○ 4.470 7.768 0.500

PARAMETRIC VALUES
 BETA 0.000 HORIZT - 1.000
 SPLR-L 0.000 TRANS 1.000
 RN/L 4.000

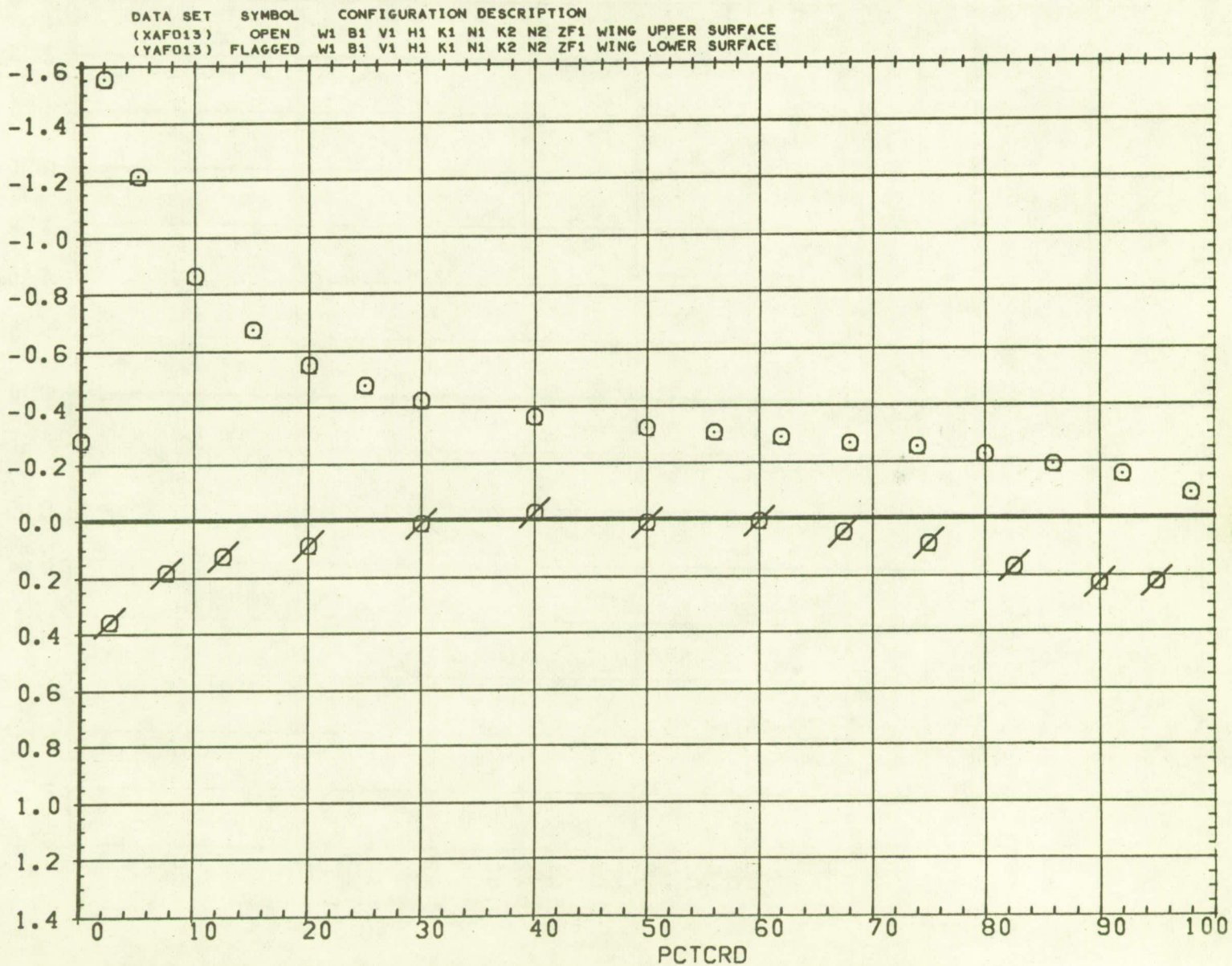

FIG. 20 WING PRESSURE DISTRIBUTION FOR FULL MODEL CONFIGURATION

SYMBOL ALPHA BL MACH
 ○ - 0.020 11.424 0.500

PARAMETRIC VALUES
 BETA 0.000 HORIZT - 1.000
 SPLR-L 0.000 TRANS 1.000
 RN/L 4.000

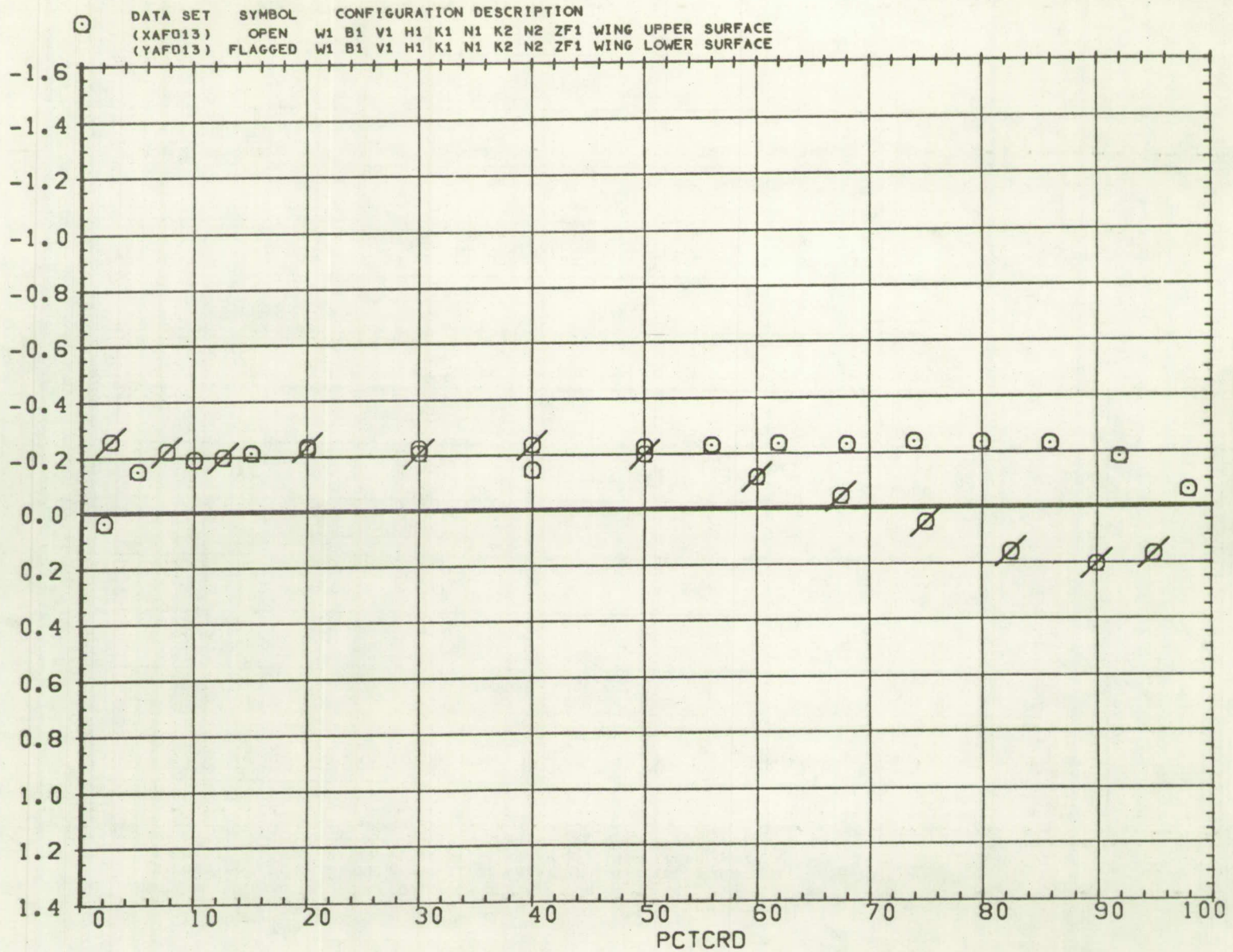

FIG. 20 WING PRESSURE DISTRIBUTION FOR FULL MODEL CONFIGURATION

SYMBOL ALPHA BL MACH
 ○ 3.450 11.424 0.500

PARAMETRIC VALUES
 BETA 0.000 HORIZT - 1.000
 SPLR-L 0.000 TRANS 1.000
 RN/L 4.000

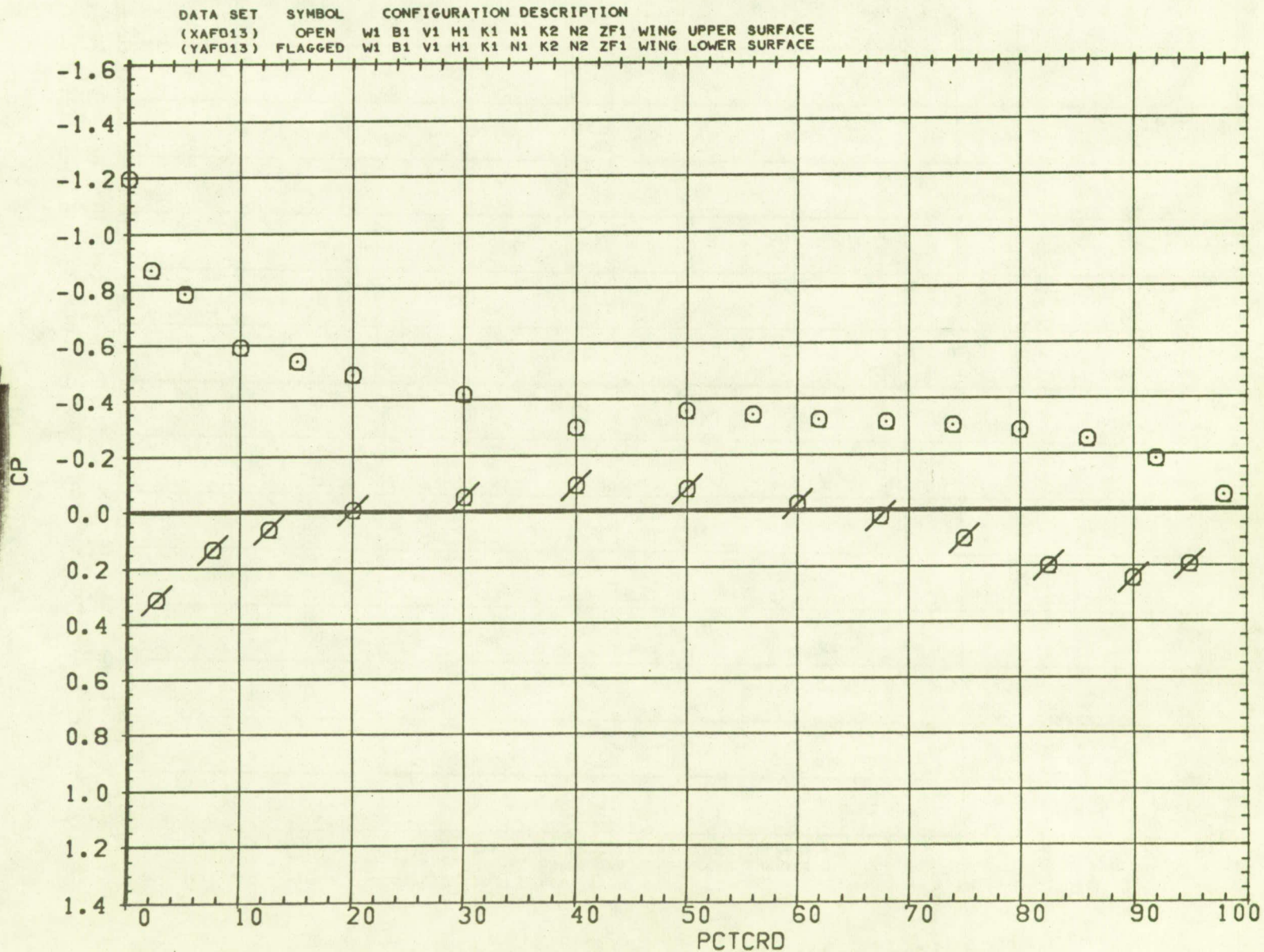

FIG. 20 WING PRESSURE DISTRIBUTION FOR FULL MODEL CONFIGURATION

SYMBOL ALPHA BL MACH
 ○ 4.470 11.424 0.500

PARAMETRIC VALUES
 BETA 0.000 HORIZT - 1.000
 SPLR-L 0.000 TRANS 1.000
 RN/L 4.000

DATA SET SYMBOL CONFIGURATION DESCRIPTION
 (XAF013) OPEN W1 B1 V1 H1 K1 N1 K2 N2 ZF1 WING UPPER SURFACE
 (YAF013) FLAGGED W1 B1 V1 H1 K1 N1 K2 N2 ZF1 WING LOWER SURFACE

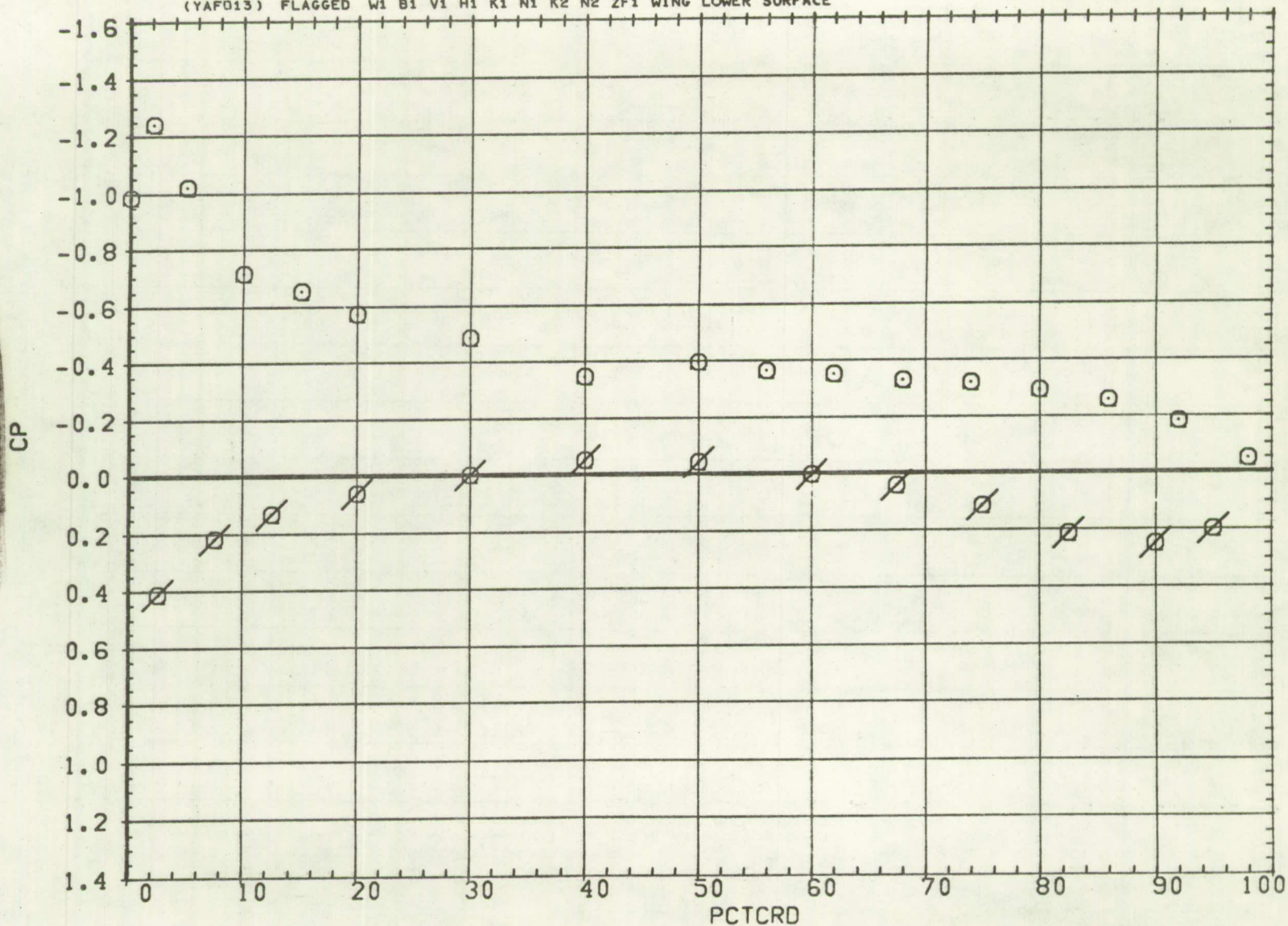

FIG. 20 WING PRESSURE DISTRIBUTION FOR FULL MODEL CONFIGURATION

SYMBOL ALPHA BL MACH
 ○ - 0.020 18.278 0.500

PARAMETRIC VALUES
 BETA 0.000 HORIZT - 1.000
 SPLR-L 0.000 TRANS 1.000
 RN/L 4.000

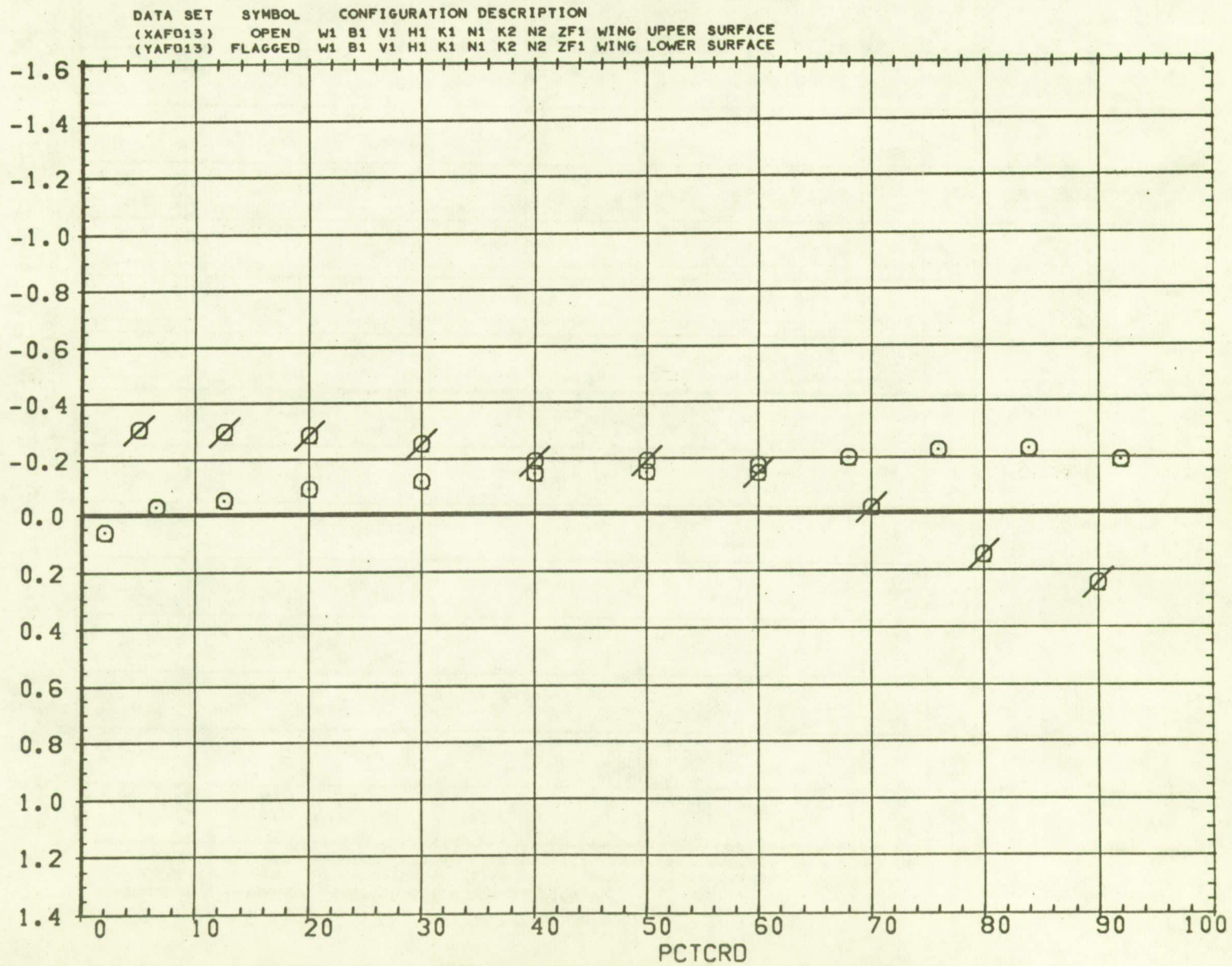

FIG. 20 WING PRESSURE DISTRIBUTION FOR FULL MODEL CONFIGURATION

SYMBOL ALPHA BL MACH
 ○ 3.450 18.278 0.500

PARAMETRIC VALUES
 BETA 0.000 HORIZT - 1.000
 SPLR-L 0.000 TRANS 1.000
 RN/L 4.000

DATA SET SYMBOL CONFIGURATION DESCRIPTION
 (XAFD13) OPEN W1 B1 V1 H1 K1 N1 K2 N2 ZF1 WING UPPER SURFACE
 (YAFD13) FLAGGED W1 B1 V1 H1 K1 N1 K2 N2 ZF1 WING LOWER SURFACE

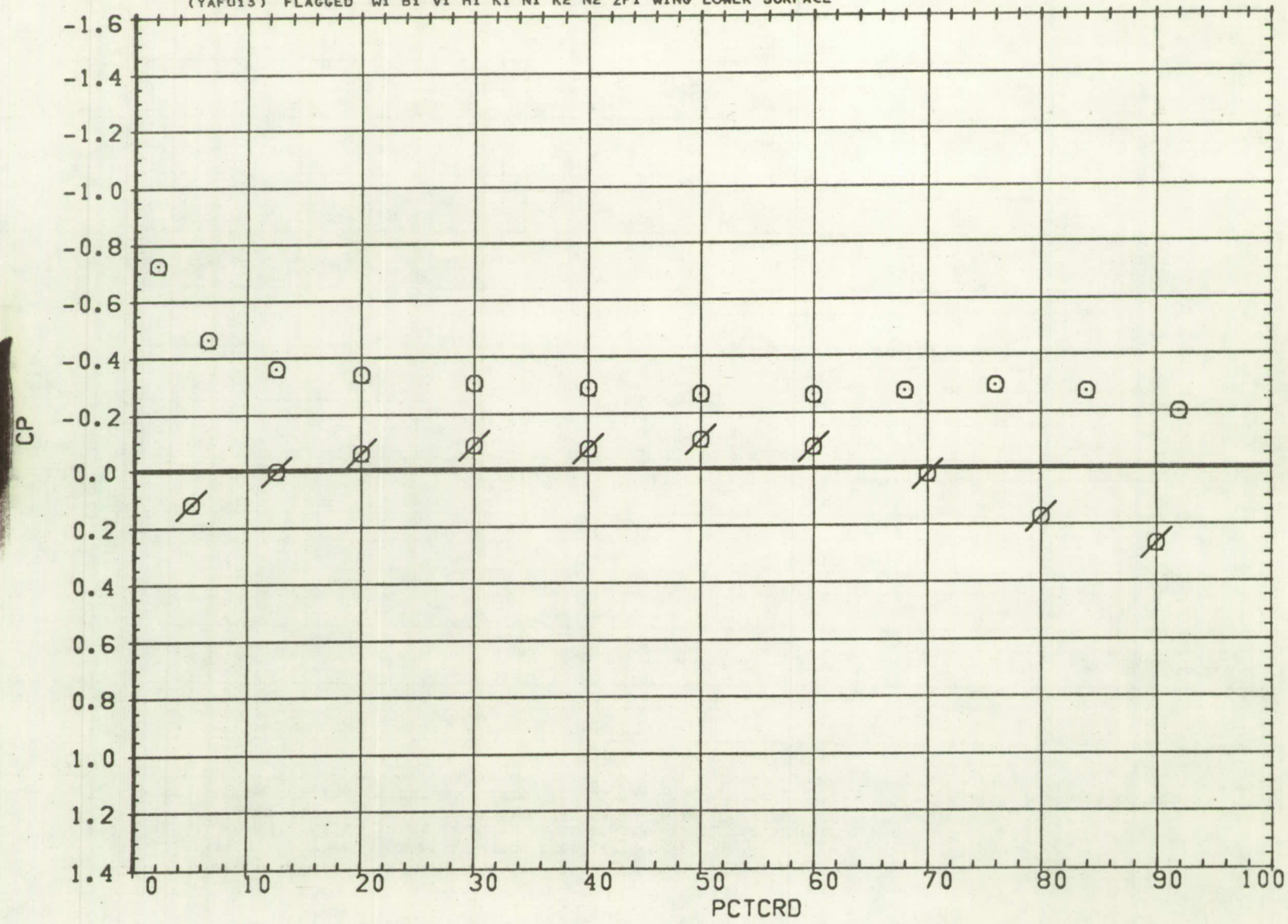

FIG. 20 WING PRESSURE DISTRIBUTION FOR FULL MODEL CONFIGURATION

SYMBOL ALPHA BL MACH
 ○ 4.470 18.278 0.500

PARAMETRIC VALUES
 BETA 0.000 HORIZT - 1.000
 SPLR-L 0.000 TRANS 1.000
 RN/L 4.000

DATA SET SYMBOL CONFIGURATION DESCRIPTION
 (XAF013) OPEN W1 B1 V1 H1 K1 N1 K2 N2 ZF1 WING UPPER SURFACE
 (YAF013) FLAGGED W1 B1 V1 H1 K1 N1 K2 N2 ZF1 WING LOWER SURFACE

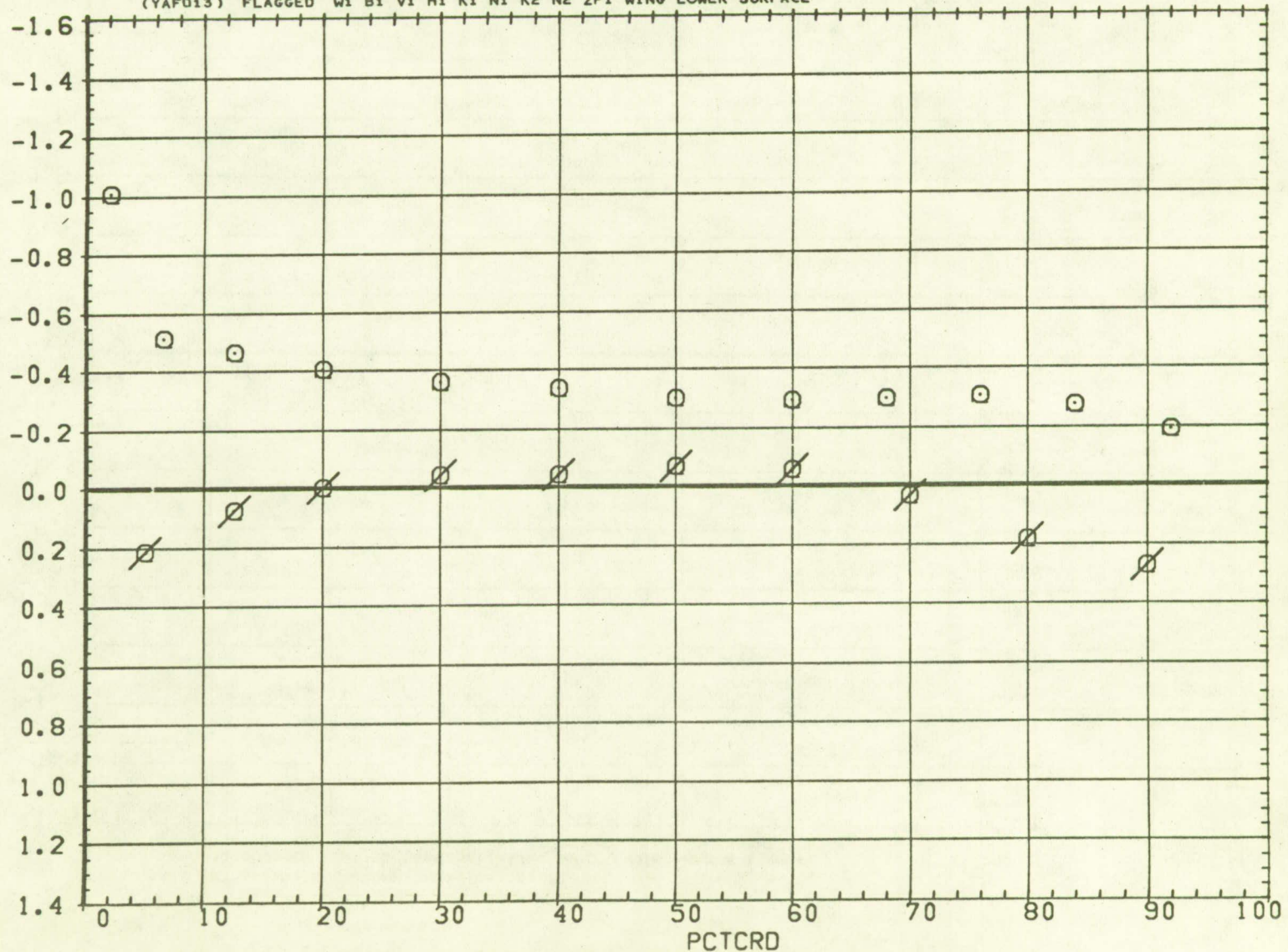

FIG. 20 WING PRESSURE DISTRIBUTION FOR FULL MODEL CONFIGURATION

SYMBOL ALPHA BL MACH
 ○ - 0.050 4.250 0.800

PARAMETRIC VALUES
 BETA 0.000 HORIZT - 1.000
 SPLR-L 0.000 TRANS 1.000
 RN/L 4.000

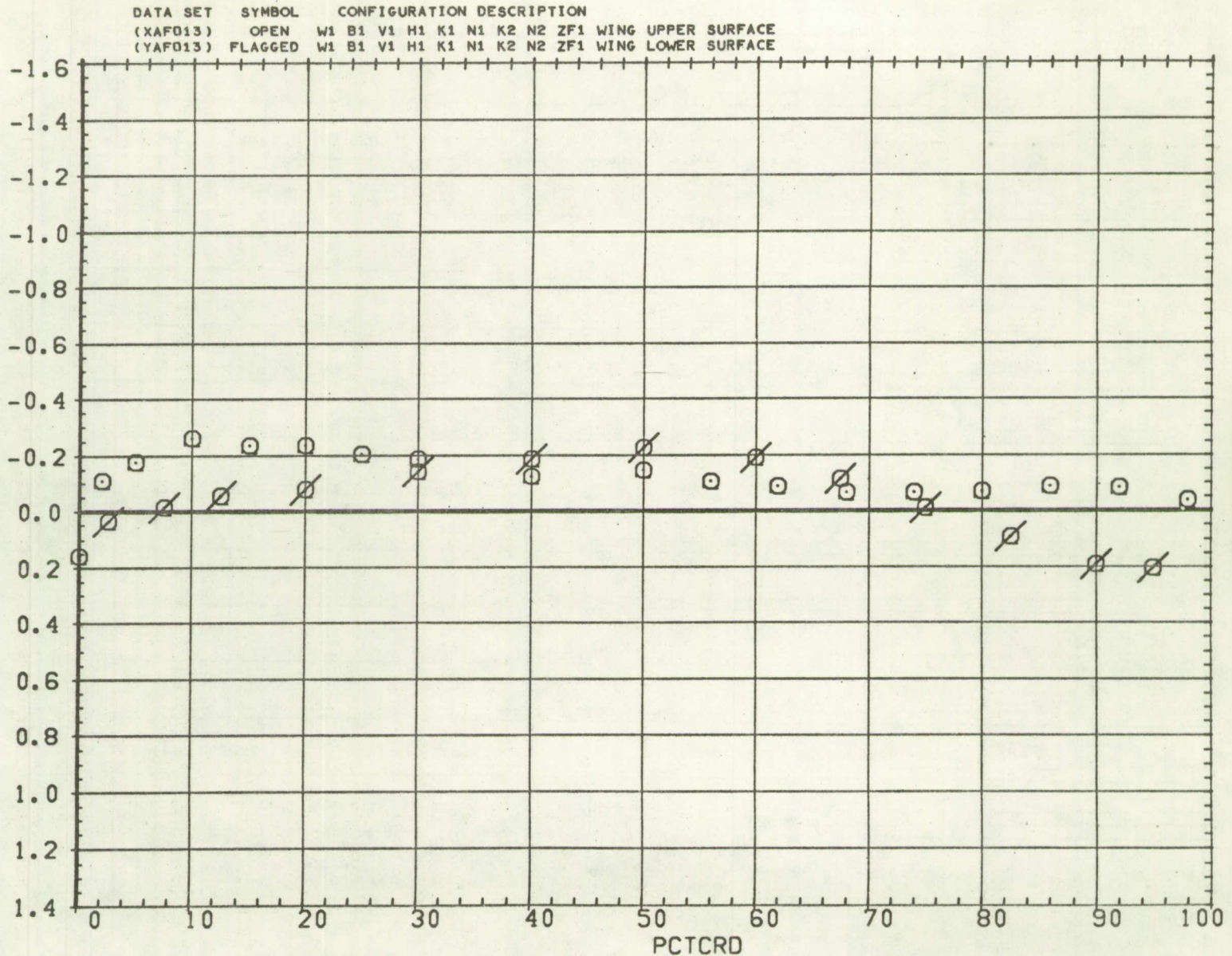

FIG. 20 WING PRESSURE DISTRIBUTION FOR FULL MODEL CONFIGURATION

SYMBOL ALPHA BL MACH
 ○ 3.440 4.250 0.800

PARAMETRIC VALUES
 BETA 0.000 HORIZT - 1.000
 SPLR-L 0.000 TRANS 1.000
 RN/L 4.000

DATA SET SYMBOL CONFIGURATION DESCRIPTION
 (XAF013) OPEN W1 B1 V1 H1 K1 N1 K2 N2 ZF1 WING UPPER SURFACE
 (YAF013) FLAGGED W1 B1 V1 H1 K1 N1 K2 N2 ZF1 WING LOWER SURFACE

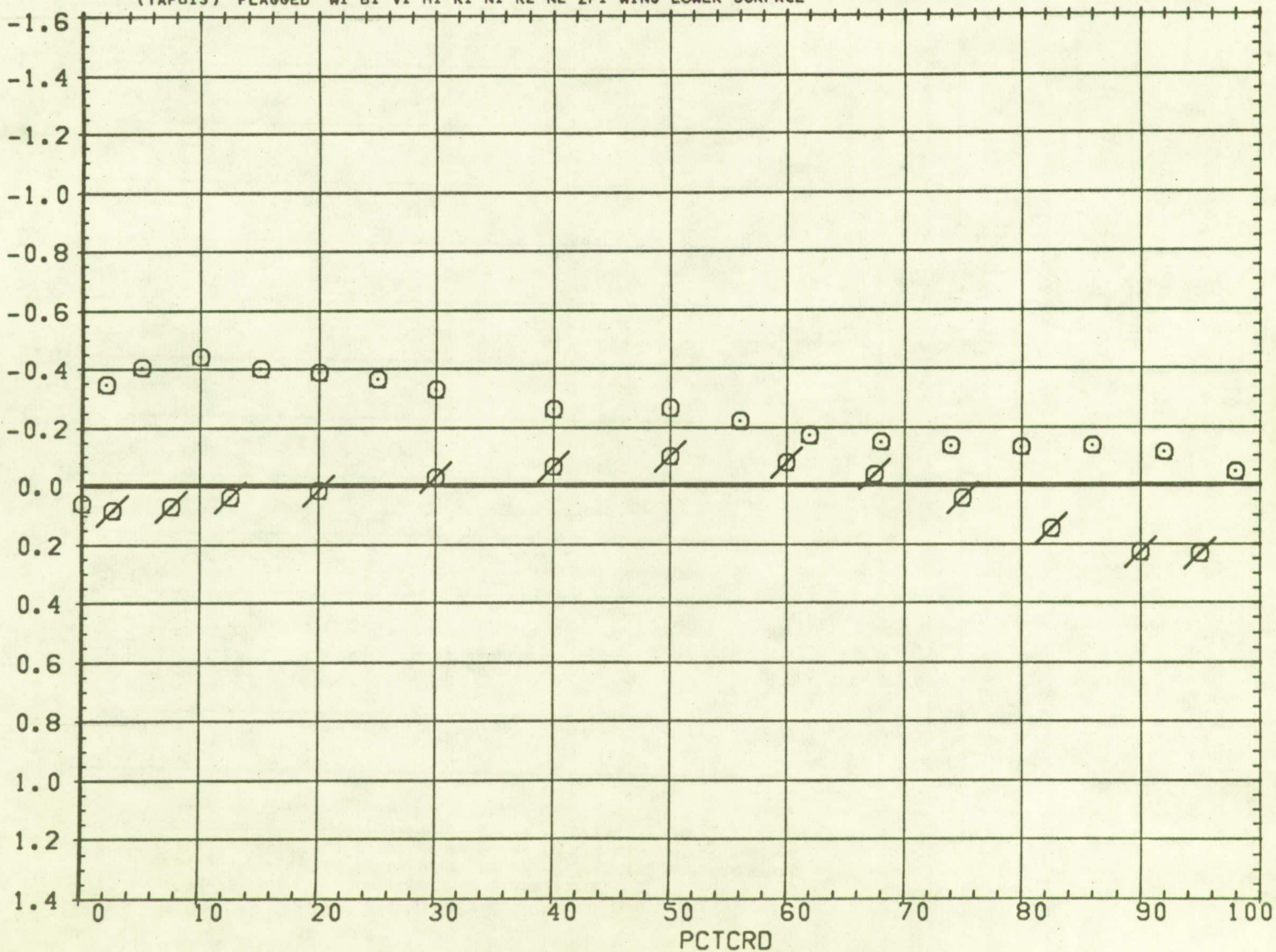

FIG. 20 WING PRESSURE DISTRIBUTION FOR FULL MODEL CONFIGURATION

SYMBOL ALPHA BL MACH
 O 7.900 4.250 0.800

PARAMETRIC VALUES
 BETA 0.000 HORIZT - 1.000
 SPLR-L 0.000 TRANS 1.000
 RN/L 4.000

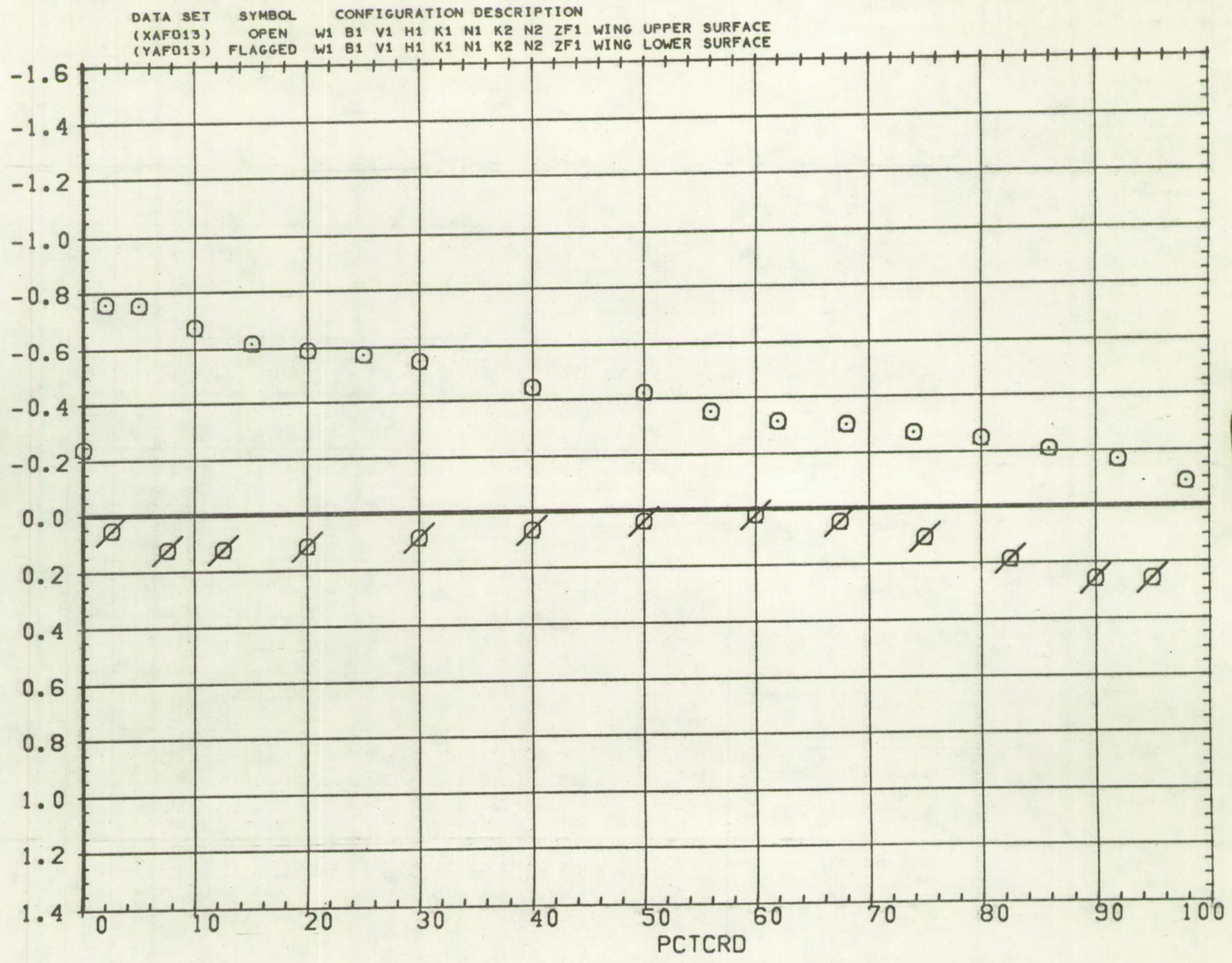

FIG. 20 WING PRESSURE DISTRIBUTION FOR FULL MODEL CONFIGURATION

SYMBOL ALPHA BL MACH
 ○ - 0.050 7.768 0.800

PARAMETRIC VALUES
 BETA 0.000 HORIZT - 1.000
 SPLR-L 0.000 TRANS 1.000
 RN/L 4.000

DATA SET SYMBOL CONFIGURATION DESCRIPTION
 (XAFD13) OPEN W1 B1 V1 H1 K1 N1 K2 N2 ZF1 WING UPPER SURFACE
 (YAFD13) FLAGGED W1 B1 V1 H1 K1 N1 K2 N2 ZF1 WING LOWER SURFACE

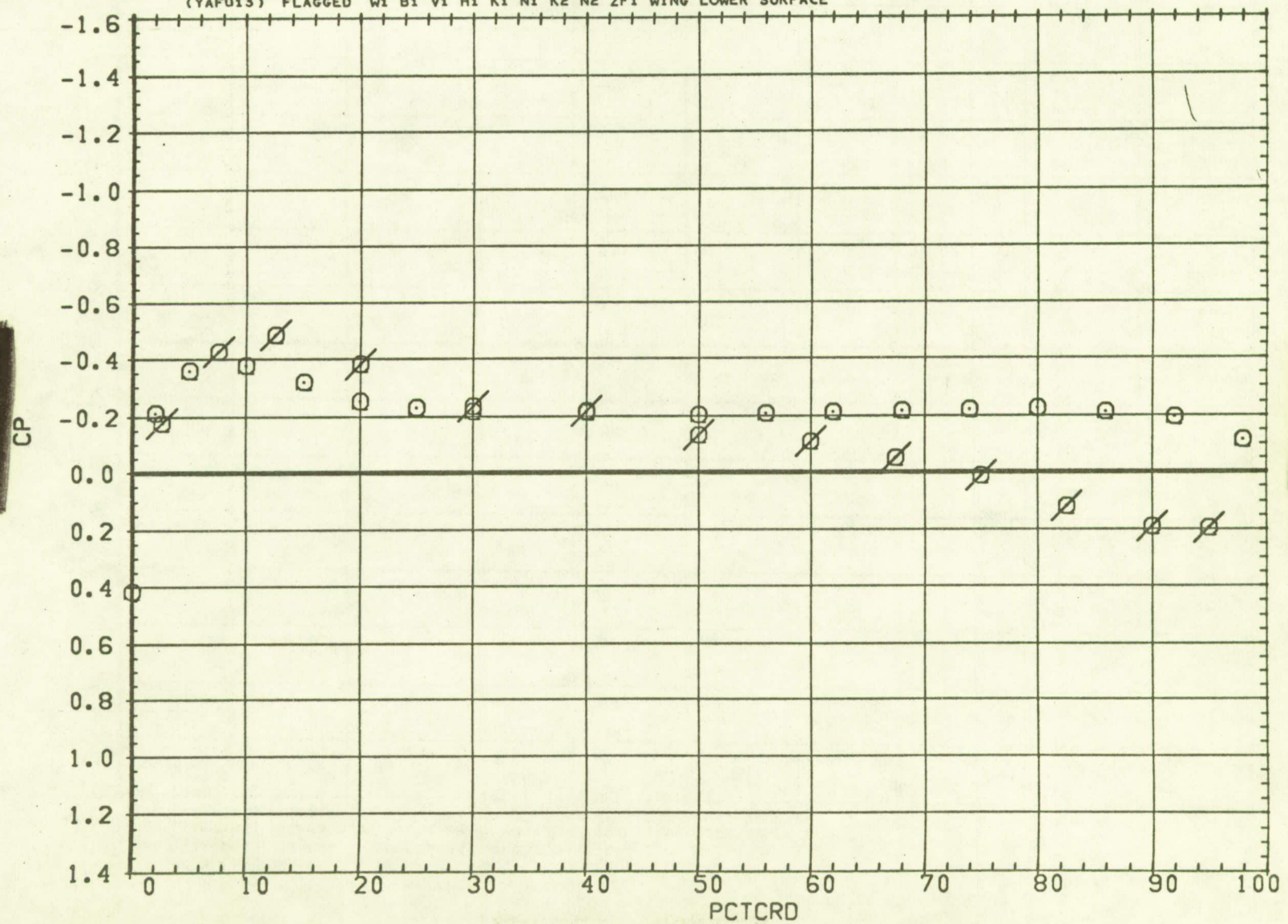

FIG. 20 WING PRESSURE DISTRIBUTION FOR FULL MODEL CONFIGURATION

SYMBOL ALPHA BL MACH
 ○ 3.440 7.768 0.800

PARAMETRIC VALUES
 BETA 0.000 HORIZT - 1.000
 SPLR-L 0.000 TRANS 1.000
 RN/L 4.000

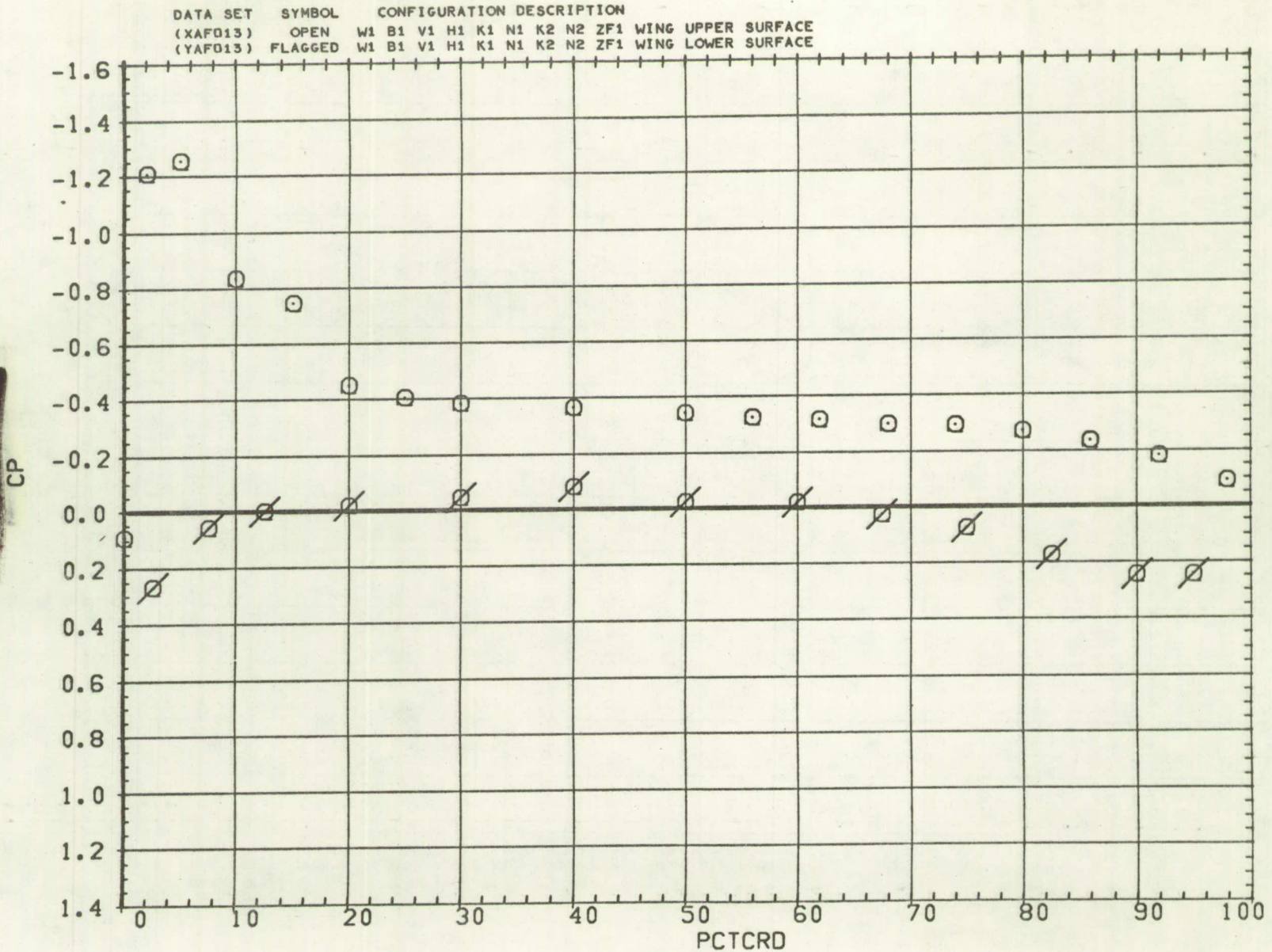

FIG. 20 WING PRESSURE DISTRIBUTION FOR FULL MODEL CONFIGURATION

SYMBOL ALPHA BL MACH
 ○ 7.900 7.766 0.800

PARAMETRIC VALUES
 BETA 0.000 HORIZT - 1.000
 SPLR-L 0.000 TRANS 1.000
 RN/L 4.000

DATA SET SYMBOL CONFIGURATION DESCRIPTION
 (XAFD13) OPEN W1 B1 V1 H1 K1 N1 K2 N2 ZF1 WING UPPER SURFACE
 (YAFD13) FLAGGED W1 B1 V1 H1 K1 N1 K2 N2 ZF1 WING LOWER SURFACE

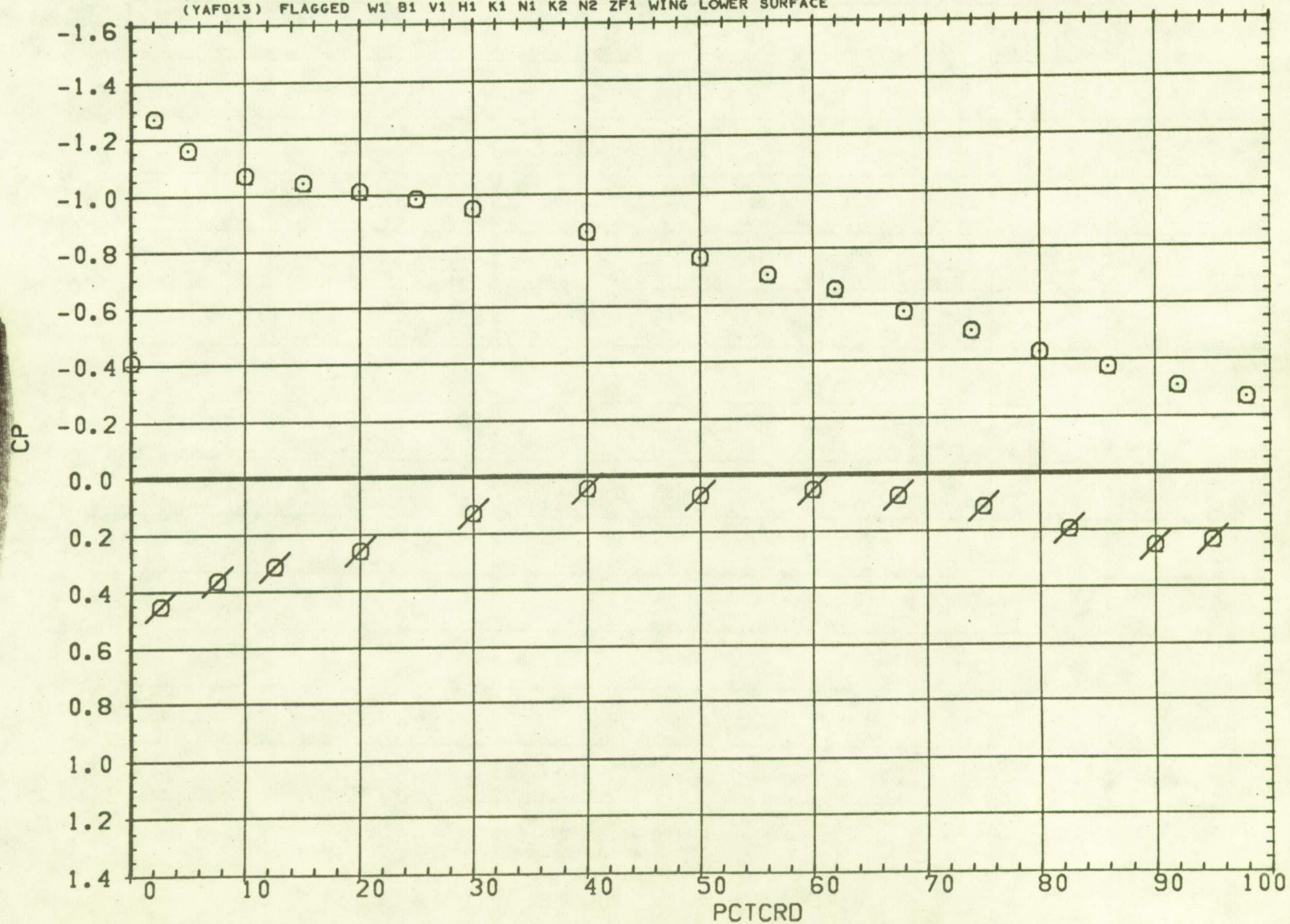

FIG. 20 WING PRESSURE DISTRIBUTION FOR FULL MODEL CONFIGURATION

SYMBOL	ALPHA	BL	MACH
○	0.050	11.424	0.800

PARAMETRIC VALUES		
BETA	0.000	HORIZT - 1.000
SPLR-L	0.000	TRANS 1.000
RN/L	4.000	

DATA SET	SYMBOL	CONFIGURATION DESCRIPTION									
(XAFD13)	OPEN	W1	B1	V1	H1	K1	N1	K2	N2	ZF1	WING UPPER SURFACE
(YAFD13)	FLAGGED	W1	B1	V1	H1	K1	N1	K2	N2	ZF1	WING LOWER SURFACE

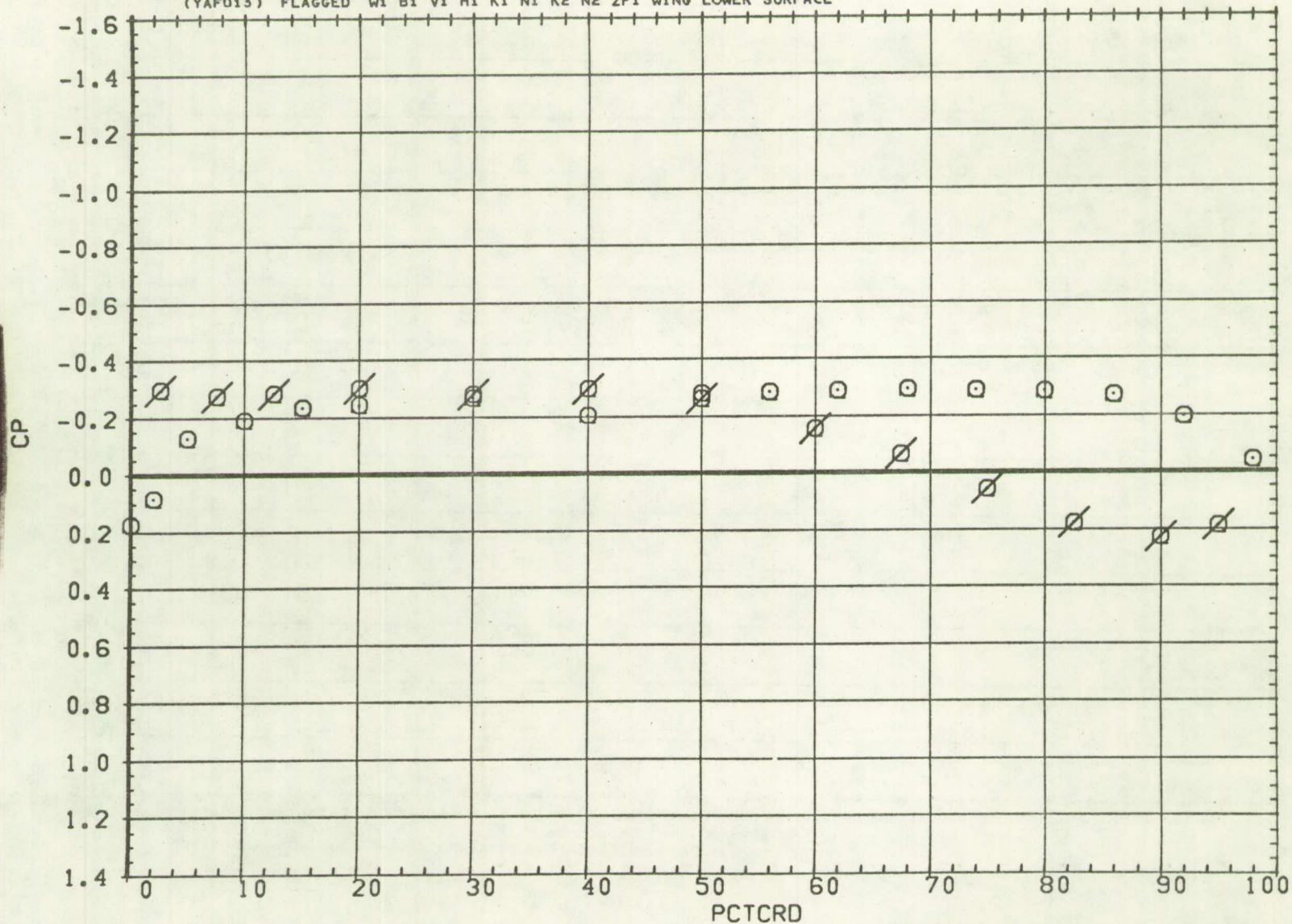

FIG. 20 WING PRESSURE DISTRIBUTION FOR FULL MODEL CONFIGURATION

SYMBOL ALPHA BL MACH
 ○ 3.440 11.424 0.800

PARAMETRIC VALUES
 BETA 0.000 HORIZT - 1.000
 SPLR-L 0.000 TRANS 1.000
 RN/L 4.000

DATA SET SYMBOL CONFIGURATION DESCRIPTION
 (XAFD13) OPEN W1 B1 V1 H1 K1 N1 K2 N2 ZF1 WING UPPER SURFACE
 (YAFD13) FLAGGED W1 B1 V1 H1 K1 N1 K2 N2 ZF1 WING LOWER SURFACE

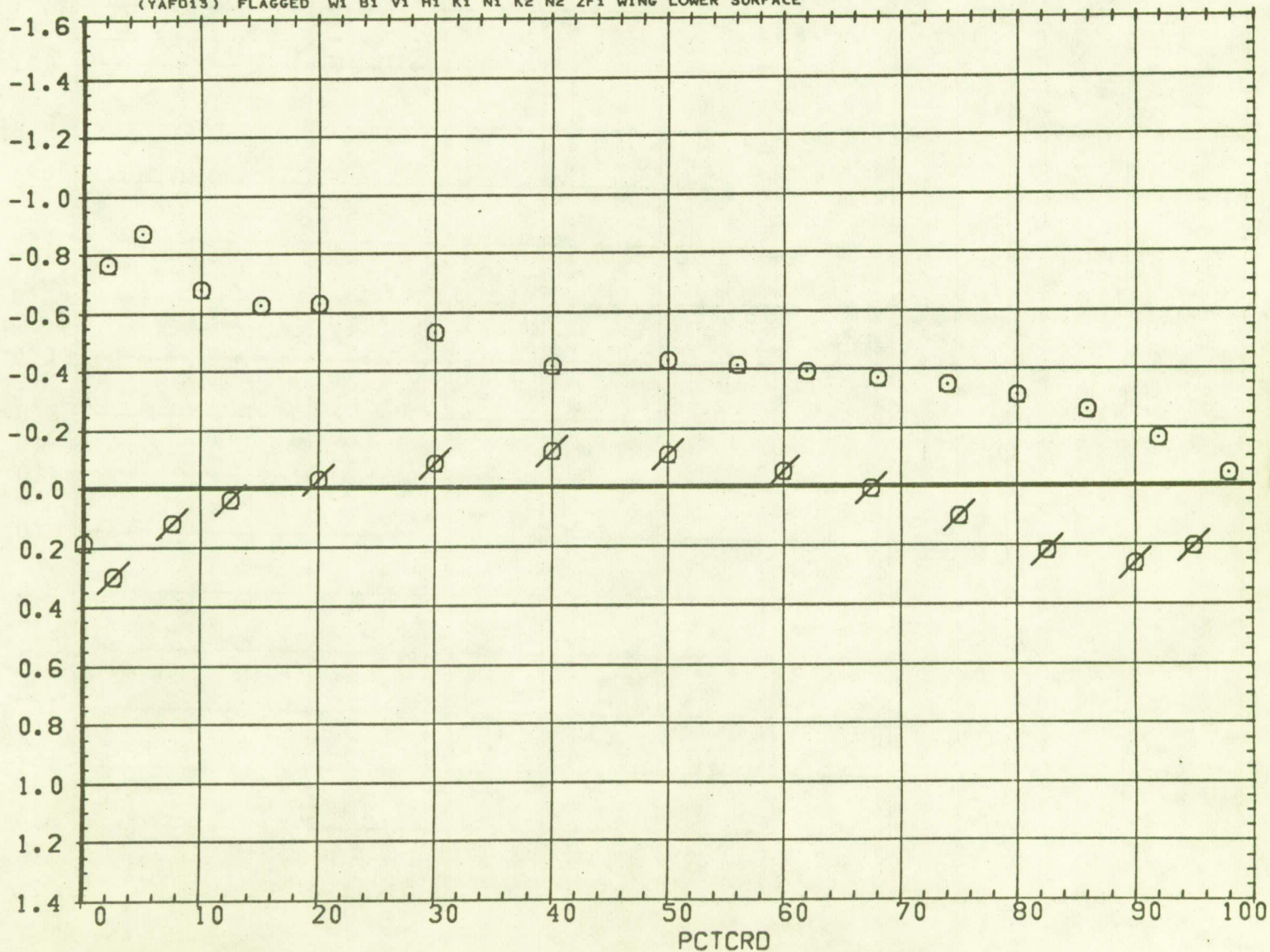

FIG. 20 WING PRESSURE DISTRIBUTION FOR FULL MODEL CONFIGURATION

SYMBOL ALPHA BL MACH
 ○ 7.900 11.424 0.800

PARAMETRIC VALUES
 BETA 0.000 HORIZT - 1.000
 SPLR-L 0.000 TRANS 1.000
 RN/L 4.000

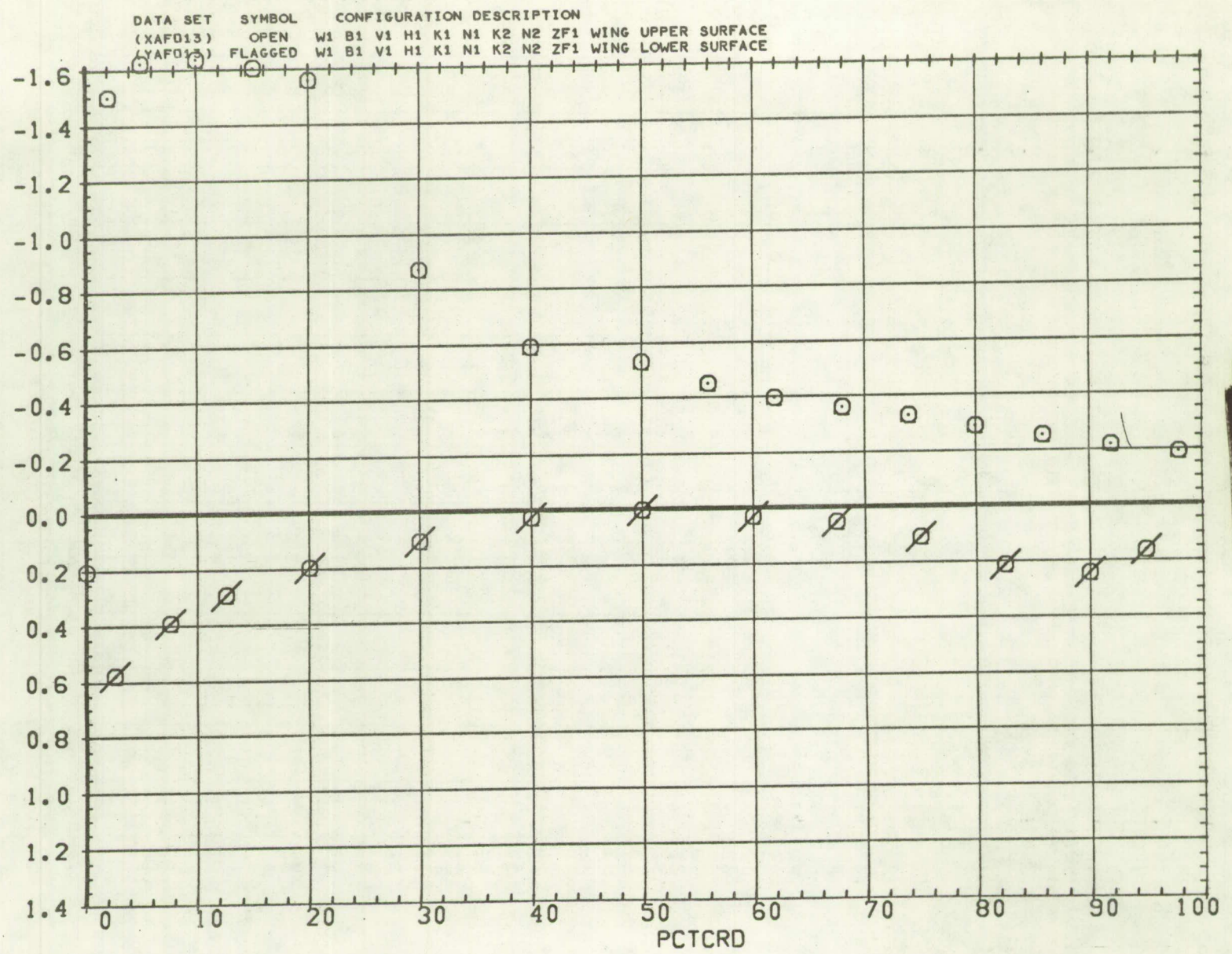

FIG. 20 WING PRESSURE DISTRIBUTION FOR FULL MODEL CONFIGURATION

SYMBOL ALPHA BL MACH
 O - 0.050 18.278 0.800

PARAMETRIC VALUES
 BETA 0.000 HORIZT - 1.000
 SPLR-L 0.000 TRANS 1.000
 RN/L 4.000

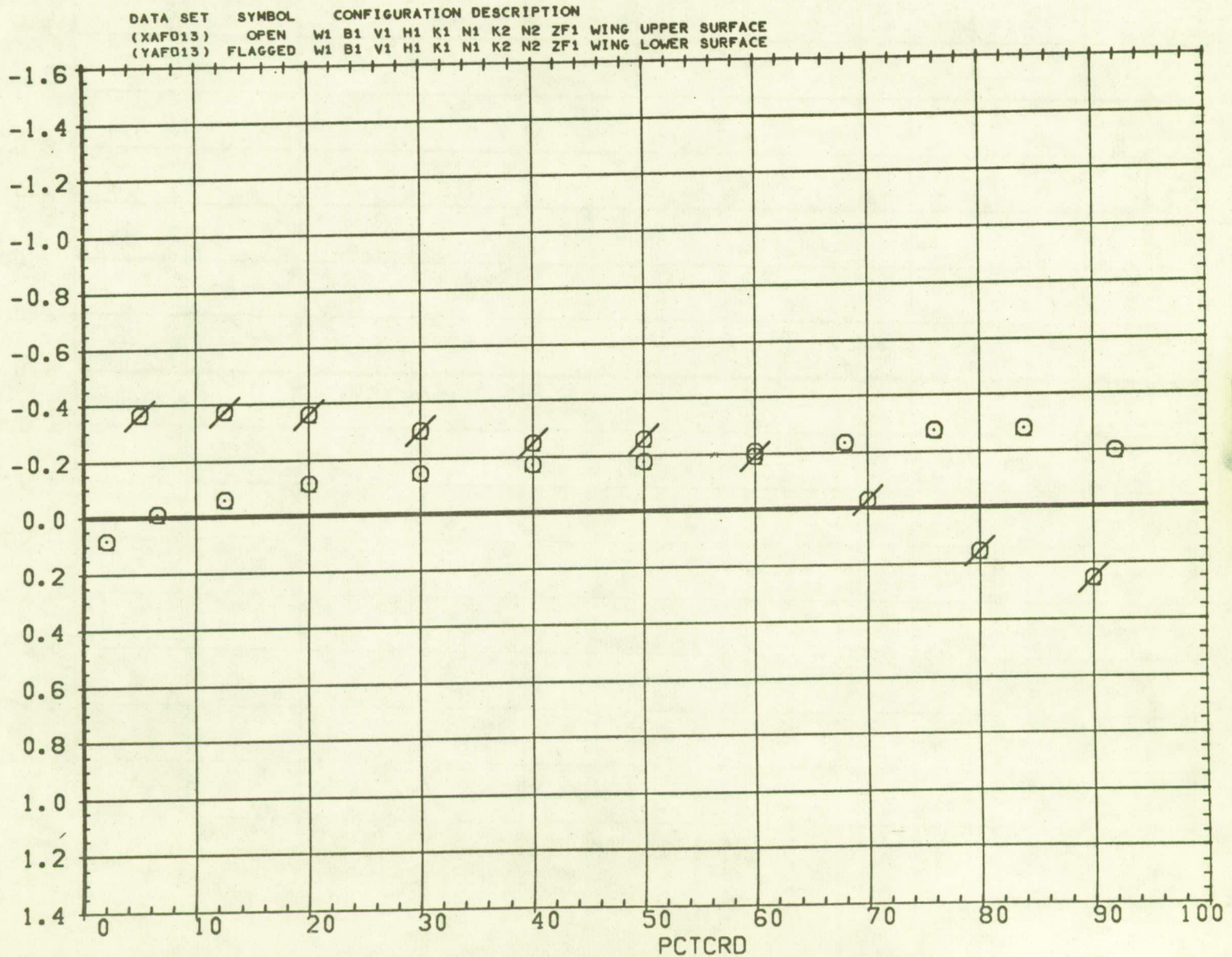

FIG. 20 WING PRESSURE DISTRIBUTION FOR FULL MODEL CONFIGURATION

SYMBOL ALPHA BL MACH
 ○ 3.440 18.278 0.800

PARAMETRIC VALUES
 BETA 0.000 HORIZT - 1.000
 SPLR-L 0.000 TRANS 1.000
 RN/L 4.000

DATA SET SYMBOL CONFIGURATION DESCRIPTION
 (XAFD13) OPEN W1 B1 V1 H1 K1 N1 K2 N2 ZF1 WING UPPER SURFACE
 (YAFD13) FLAGGED W1 B1 V1 H1 K1 N1 K2 N2 ZF1 WING LOWER SURFACE

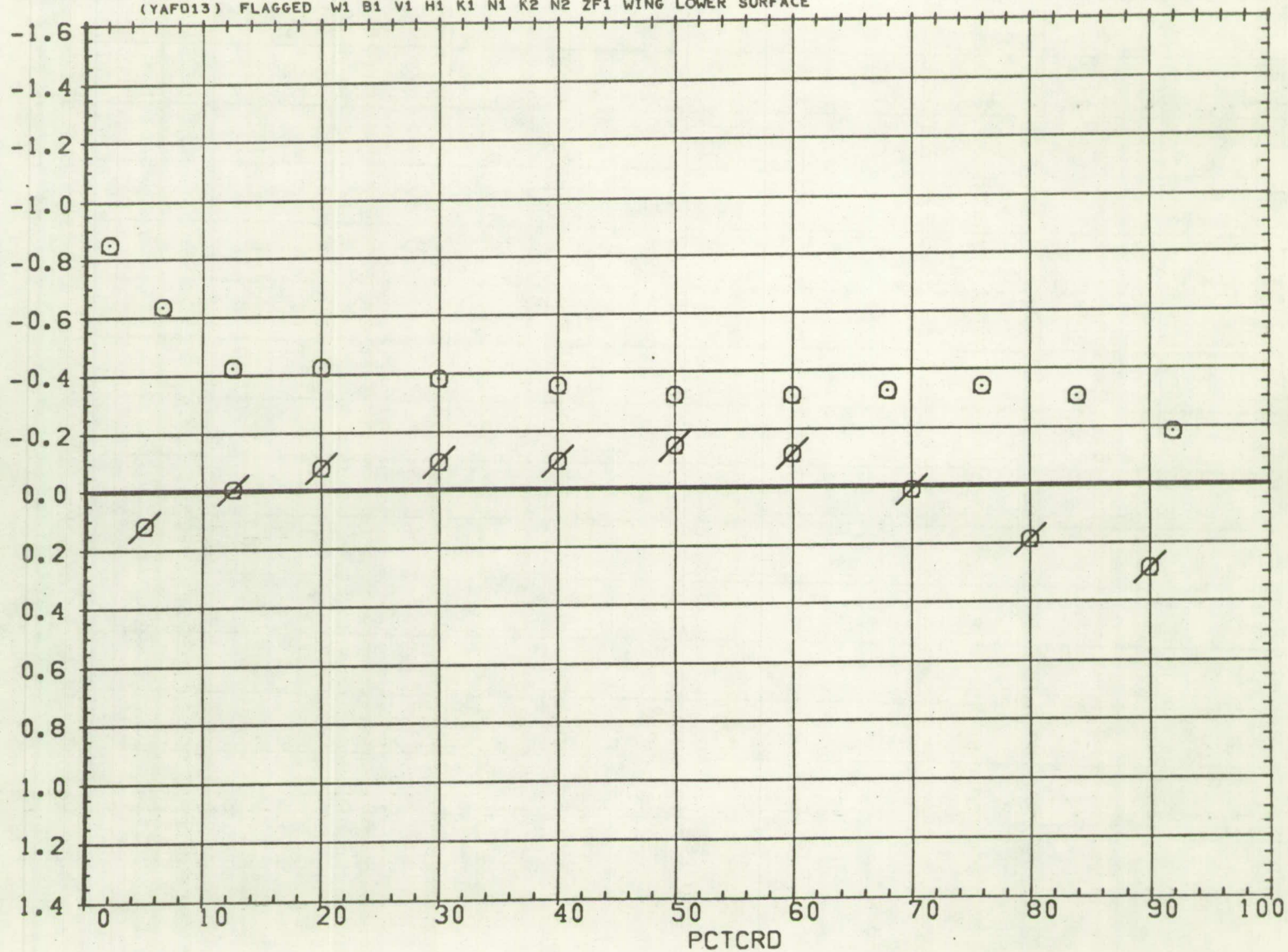
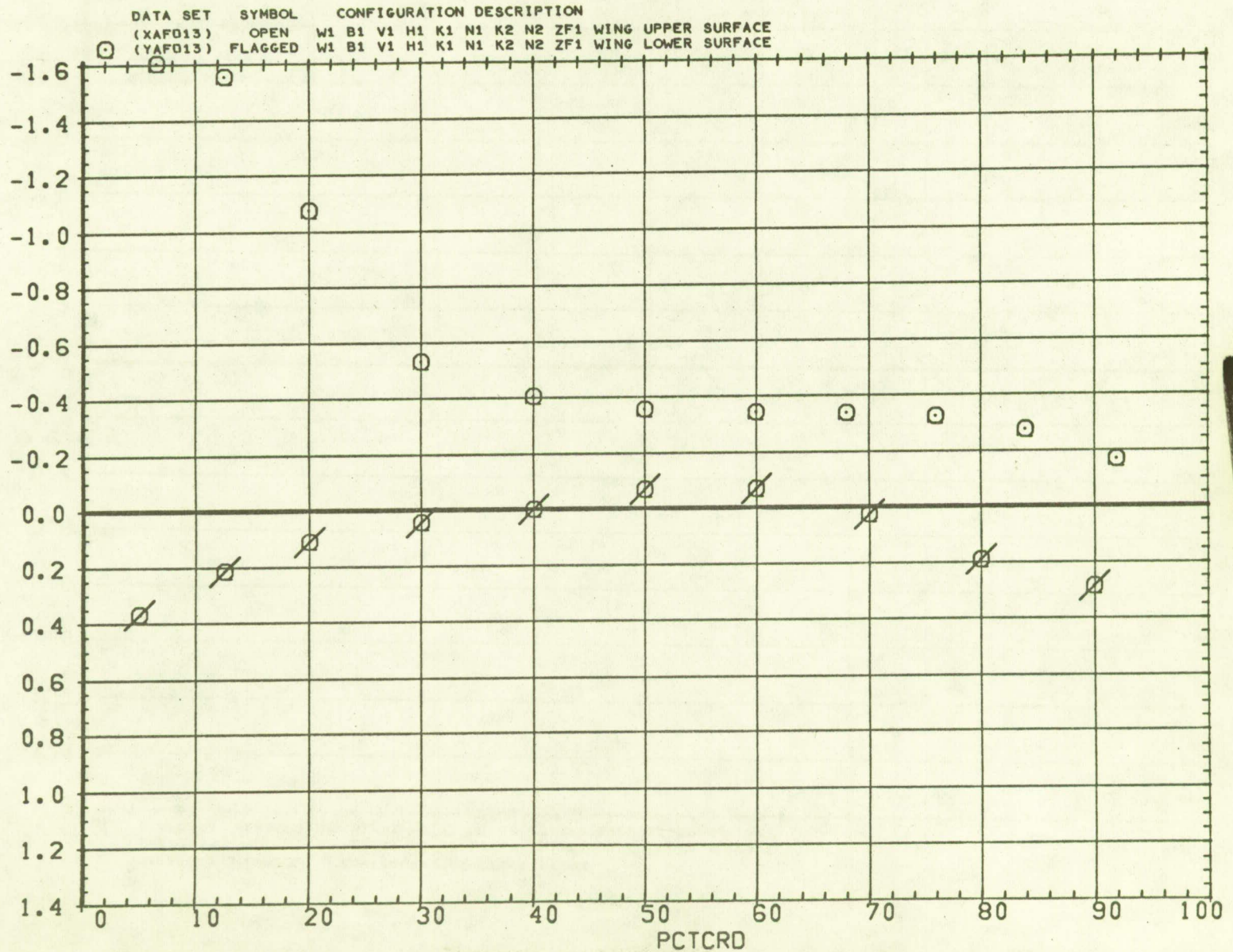

FIG. 20 WING PRESSURE DISTRIBUTION FOR FULL MODEL CONFIGURATION

SYMBOL ALPHA BL MACH
 ○ 7.900 18.278 0.800

PARAMETRIC VALUES
 BETA 0.000 HORIZT - 1.000
 SPLR-L 0.000 TRANS 1.000
 RN/L 4.000



Cp

FIG. 20 WING PRESSURE DISTRIBUTION FOR FULL MODEL CONFIGURATION

SYMBOL ALPHA BL MACH
 ○ - 0.090 4.250 0.901

PARAMETRIC VALUES
 BETA 0.000 HORIZT - 1.000
 SPLR-L 0.000 TRANS 1.000
 RN/L 4.000

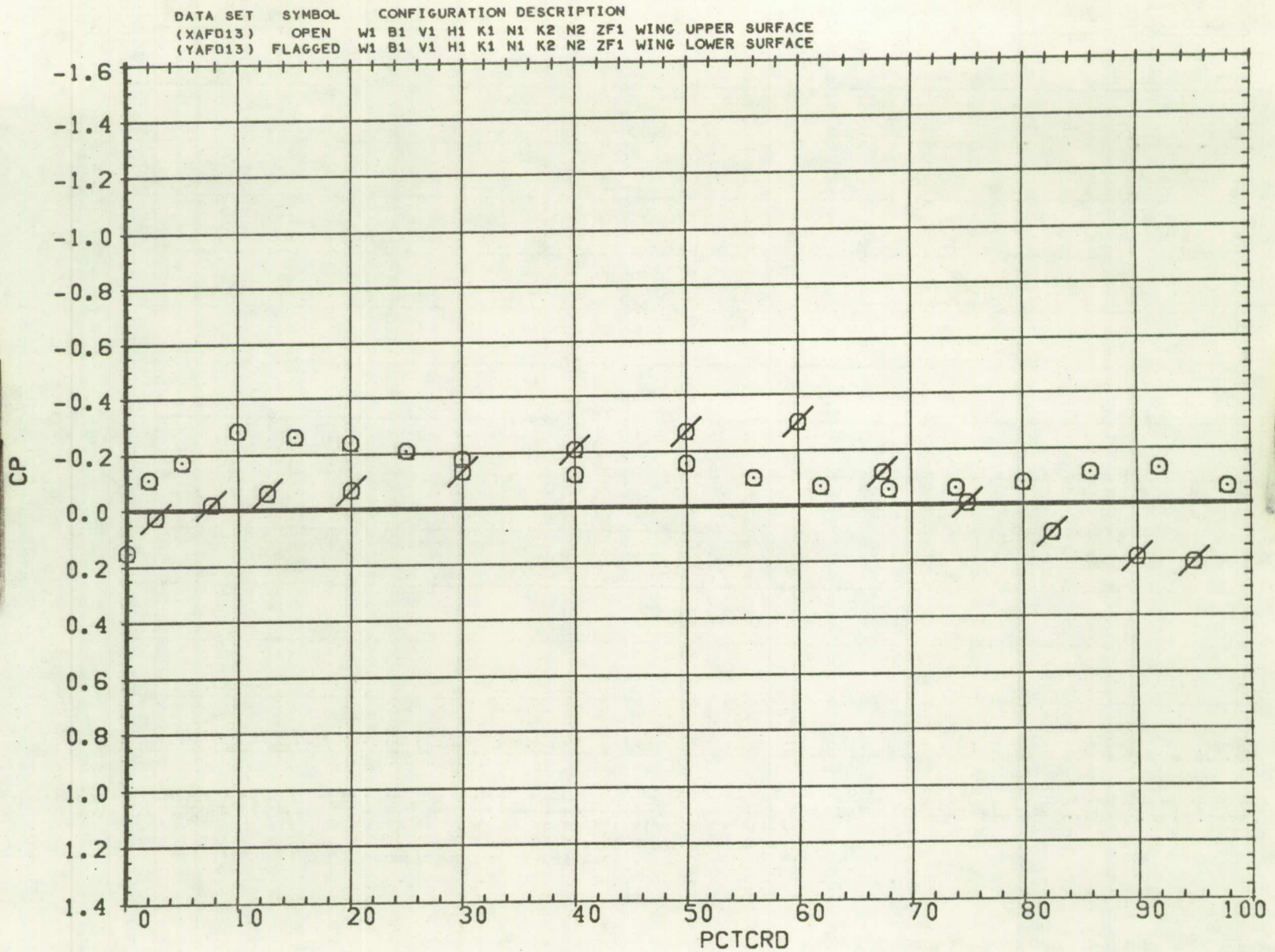

FIG. 20 WING PRESSURE DISTRIBUTION FOR FULL MODEL CONFIGURATION

SYMBOL	ALPHA	BL	MACH
○	3.460	4.250	0.901

PARAMETRIC VALUES			
BETA	0.000	HORIZT	- 1.000
SPLR-L	0.000	TRANS	1.000
RN/L	4.000		

DATA SET	SYMBOL	CONFIGURATION DESCRIPTION													
(XAFD13)	OPEN	W1	B1	V1	H1	K1	N1	K2	N2	ZF1	WING UPPER SURFACE				
(YAFD13)	FLAGGED	W1	B1	V1	H1	K1	N1	K2	N2	ZF1	WING LOWER SURFACE				

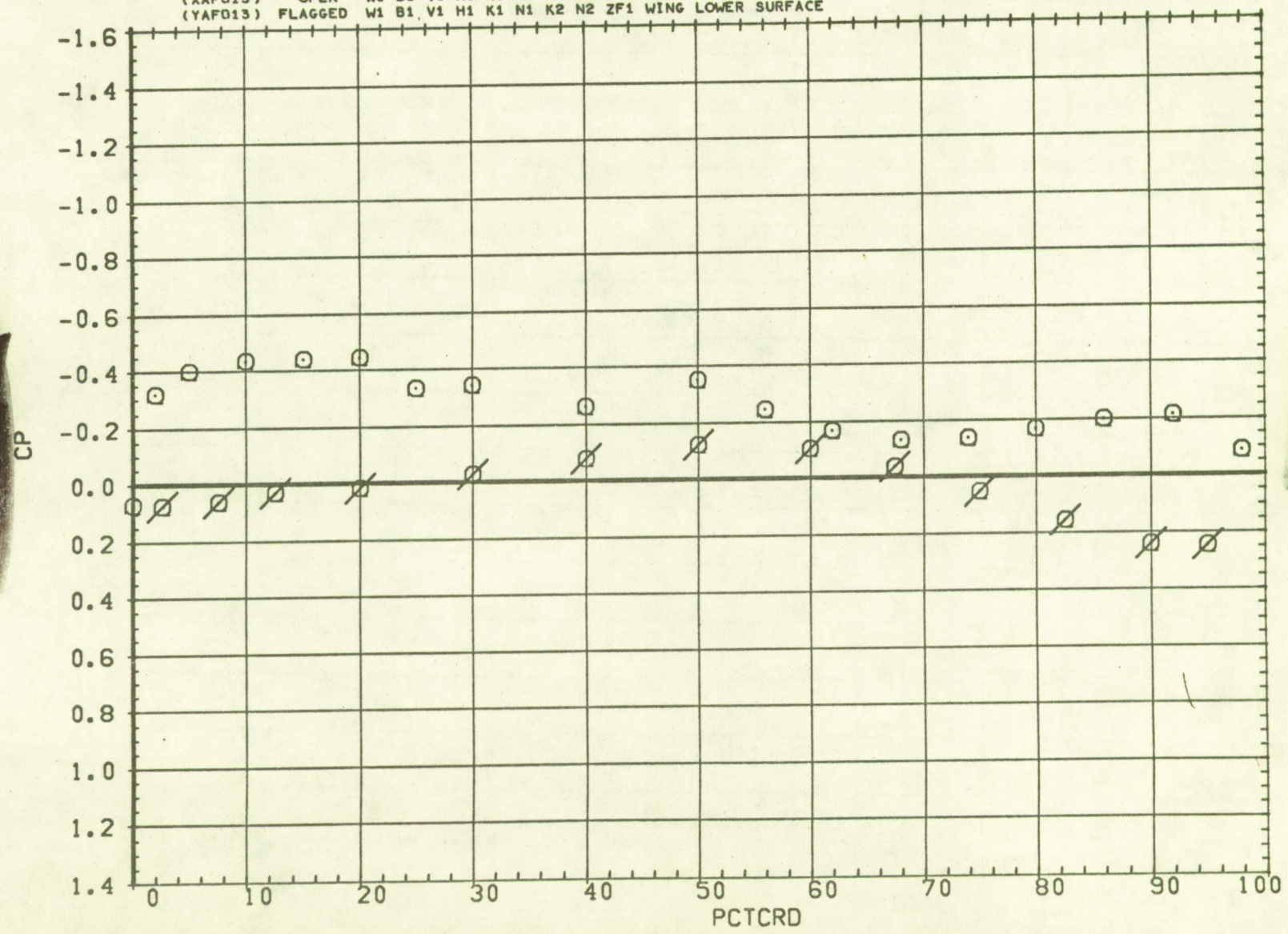

FIG. 20 WING PRESSURE DISTRIBUTION FOR FULL MODEL CONFIGURATION

SYMBOL	ALPHA	BL	MACH
○	7.890	4.250	0.901

PARAMETRIC VALUES		
BETA	0.000	HORIZT - 1.000
SPLR-L	0.000	TRANS 1.000
RN/L	4.000	

DATA SET	SYMBOL	CONFIGURATION DESCRIPTION									
(XAFD13)	OPEN	W1	B1	V1	H1	K1	N1	K2	N2	ZF1	WING UPPER SURFACE
(YAFD13)	FLAGGED	W1	B1	V1	H1	K1	N1	K2	N2	ZF1	WING LOWER SURFACE

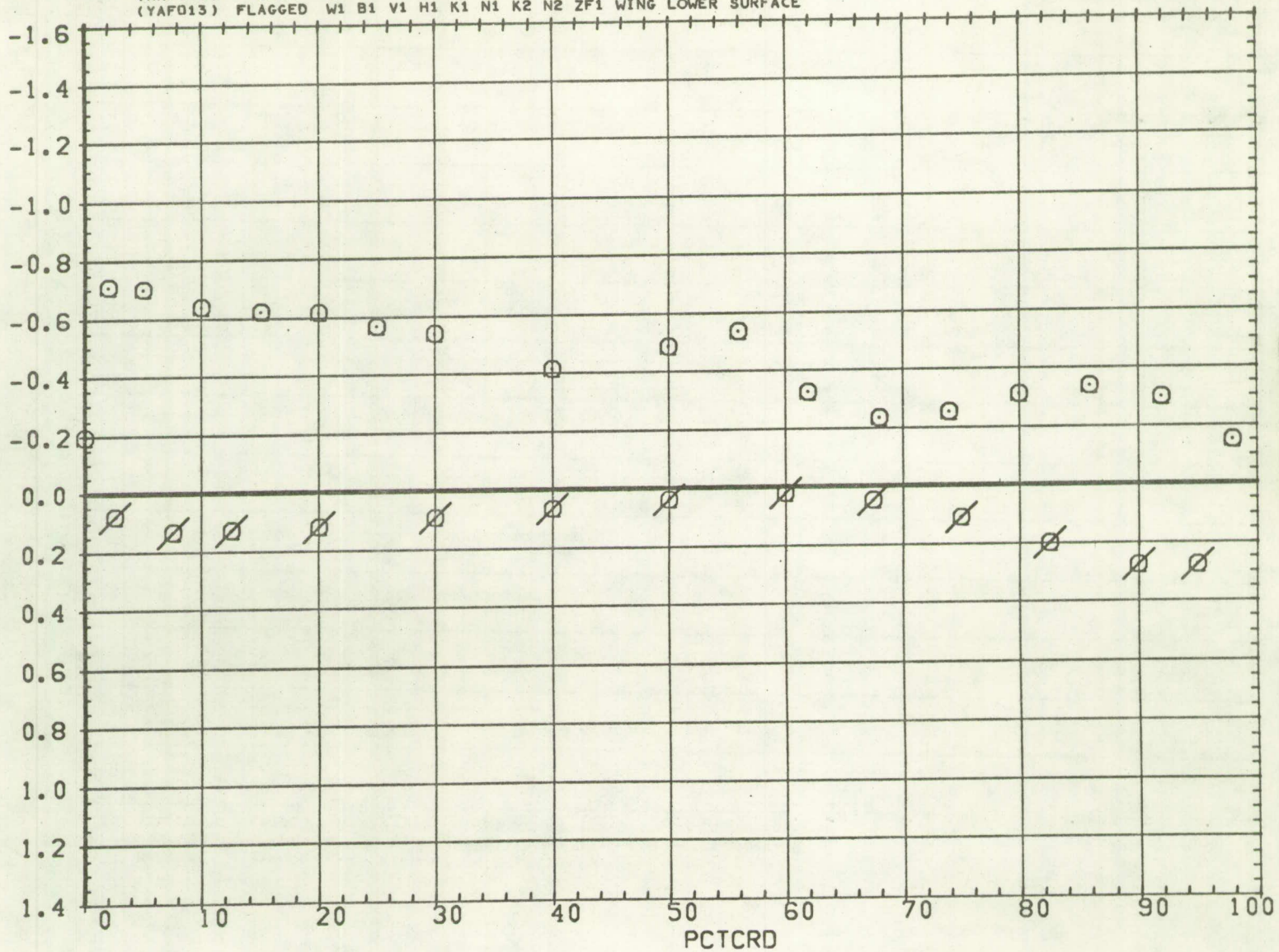

FIG. 20 WING PRESSURE DISTRIBUTION FOR FULL MODEL CONFIGURATION

SYMBOL ALPHA BL MACH
 ○ - 0.090 7.768 0.901

PARAMETRIC VALUES
 BETA 0.000 HORIZT - 1.000
 SPLR-L 0.000 TRANS 1.000
 RN/L 4.000

DATA SET SYMBOL CONFIGURATION DESCRIPTION
 (XAFD13) OPEN W1 B1 V1 H1 K1 N1 K2 N2 ZF1 WING UPPER SURFACE
 (YAFD13) FLAGGED W1 B1 V1 H1 K1 N1 K2 N2 ZF1 WING LOWER SURFACE

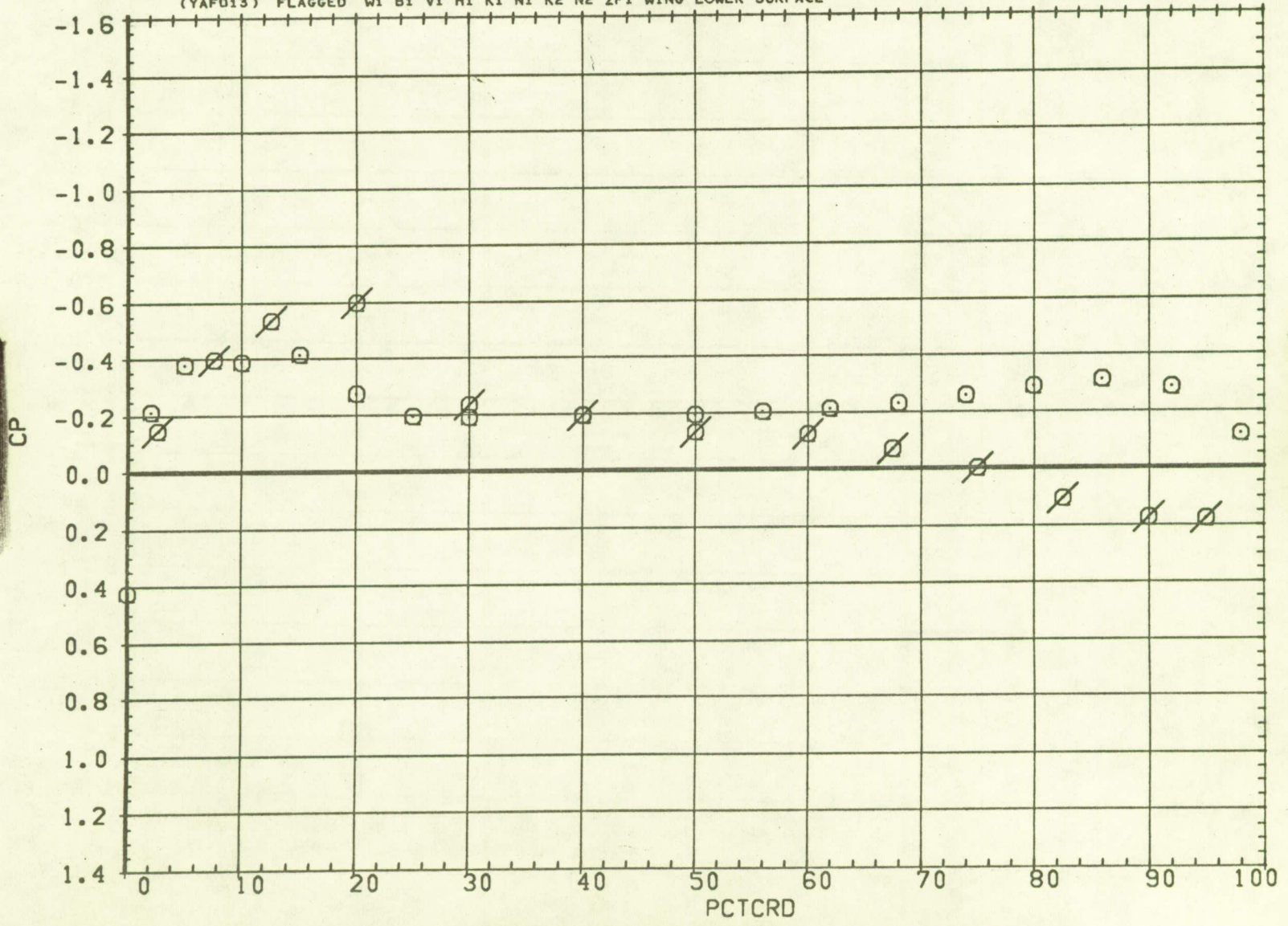

FIG. 20 WING PRESSURE DISTRIBUTION FOR FULL MODEL CONFIGURATION

SYMBOL	ALPHA	BL	MACH
○	3.460	7.768	0.901

PARAMETRIC VALUES		
BETA	0.000	HORIZT - 1.000
SPLR-L	0.000	TRANS 1.000
RN/L	4.000	

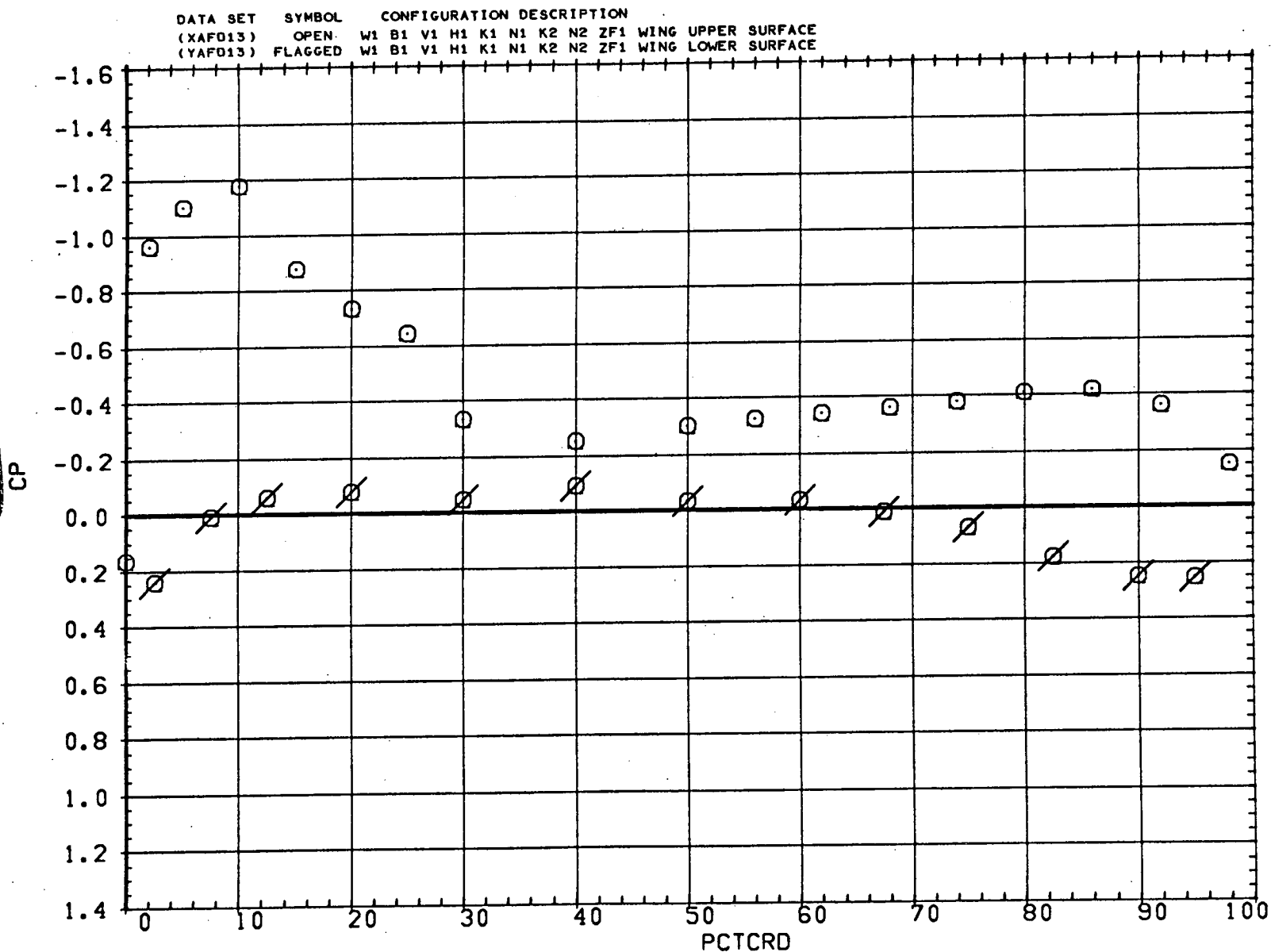

FIG. 20 WING PRESSURE DISTRIBUTION FOR FULL MODEL CONFIGURATION

SYMBOL ALPHA BL MACH
 ○ 7.890 7.768 0.901

PARAMETRIC VALUES
 BETA 0.000 HORIZT - 1.000
 SPLR-L 0.000 TRANS 1.000
 RN/L 4.000

DATA SET SYMBOL CONFIGURATION DESCRIPTION
 (XAFO13) OPEN W1 B1 V1 H1 K1 N1 K2 N2 ZF1 WING UPPER SURFACE
 (YAFO13) FLAGGED W1 B1 V1 H1 K1 N1 K2 N2 ZF1 WING LOWER SURFACE

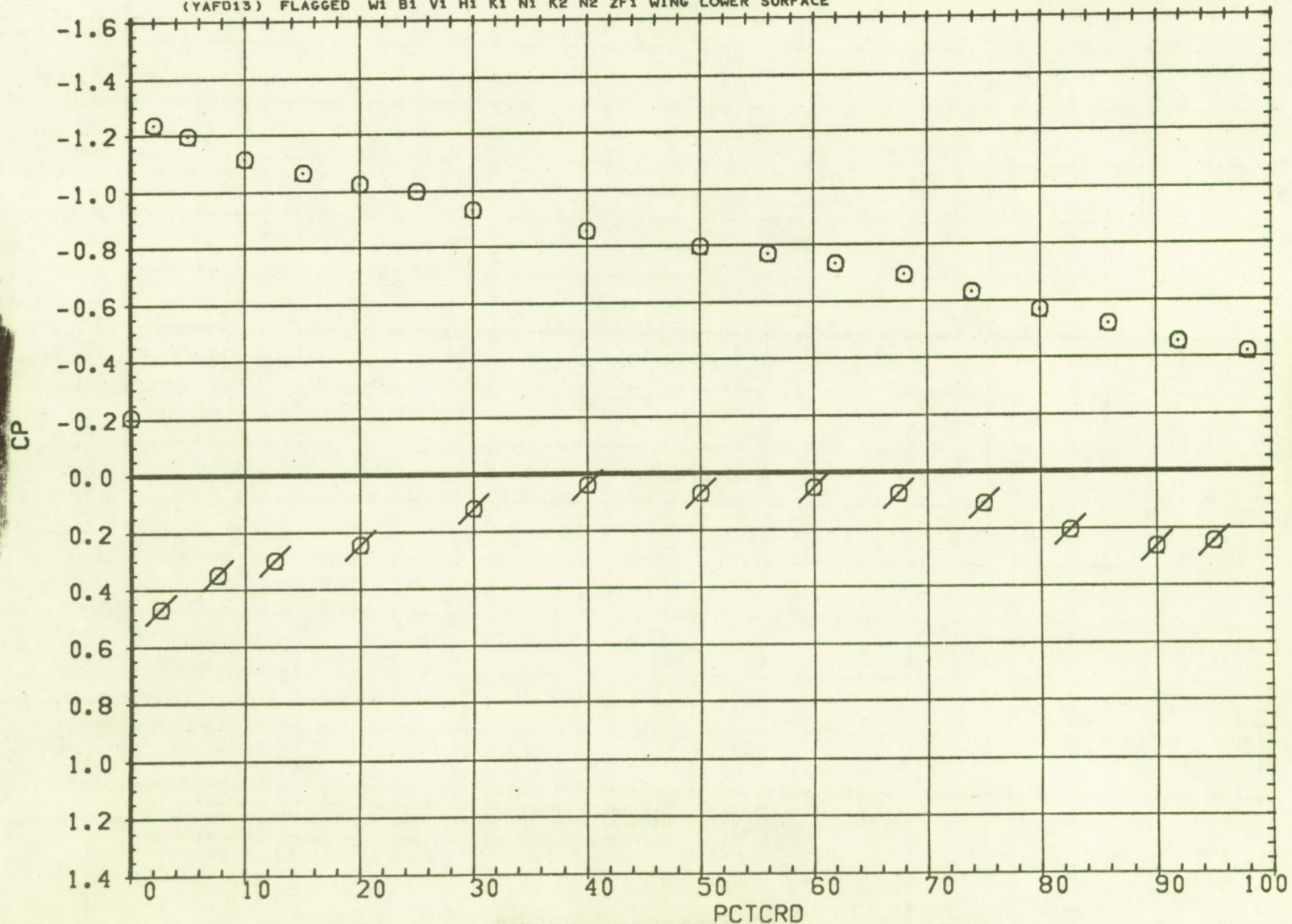

FIG. 20 WING PRESSURE DISTRIBUTION FOR FULL MODEL CONFIGURATION

SYMBOL ALPHA BL MACH
 O - 0.090 11.424 0.901

PARAMETRIC VALUES
 BETA 0.000 HORIZT - 1.000
 SPLR-L 0.000 TRANS 1.000
 RN/L 4.000

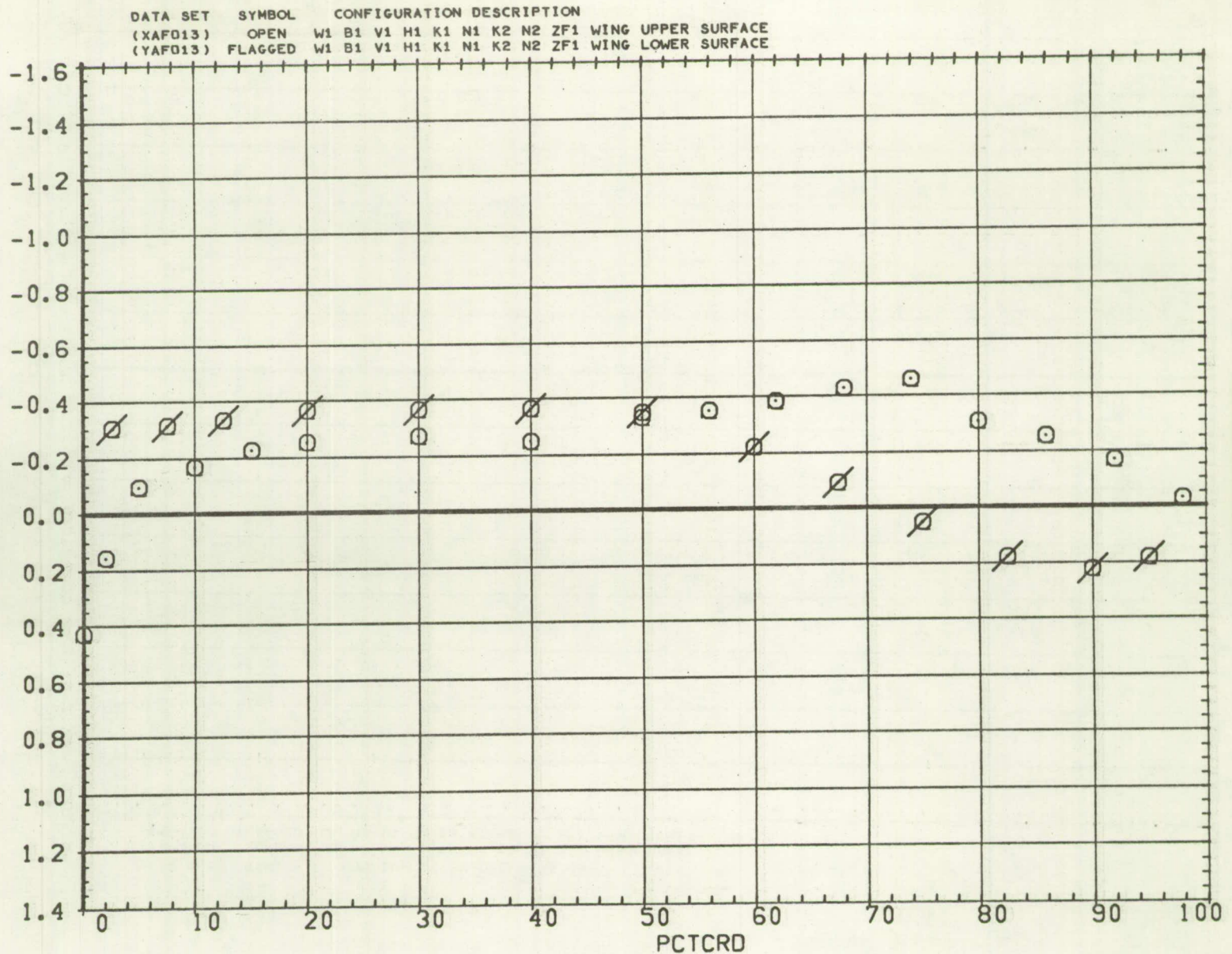

FIG. 20 WING PRESSURE DISTRIBUTION FOR FULL MODEL CONFIGURATION

SYMBOL ALPHA BL MACH
 ○ 3.460 11.424 0.901

PARAMETRIC VALUES
 BETA 0.000 HORIZT - 1.000
 SPLR-L 0.000 TRANS 1.000
 RN/L 4.000

DATA SET SYMBOL CONFIGURATION DESCRIPTION
 (XAF013) OPEN W1 B1 V1 H1 K1 N1 K2 N2 ZF1 WING UPPER SURFACE
 (YAF013) FLAGGED W1 B1 V1 H1 K1 N1 K2 N2 ZF1 WING LOWER SURFACE

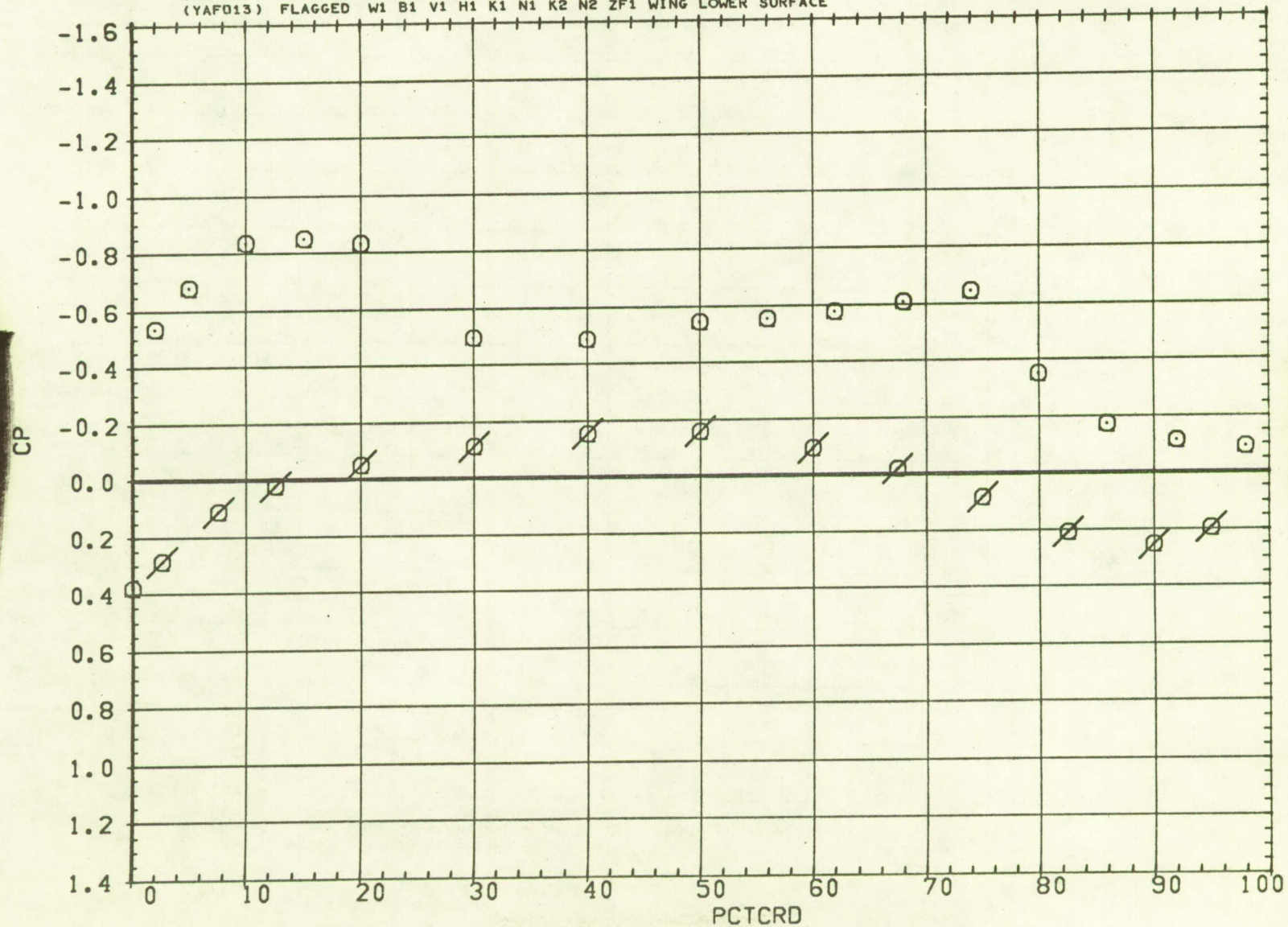

FIG. 20 WING PRESSURE DISTRIBUTION FOR FULL MODEL CONFIGURATION

SYMBOL ALPHA BL MACH
 O 7.890 11.424 0.901

PARAMETRIC VALUES
 BETA 0.000 HORIZT - 1.000
 SPLR-L 0.000 TRANS 1.000
 RN/L 4.000

DATA SET SYMBOL CONFIGURATION DESCRIPTION
 (XAFD13) OPEN W1 B1 V1 H1 K1 N1 K2 N2 ZF1 WING UPPER SURFACE
 (YAFD13) FLAGGED W1 B1 V1 H1 K1 N1 K2 N2 ZF1 WING LOWER SURFACE

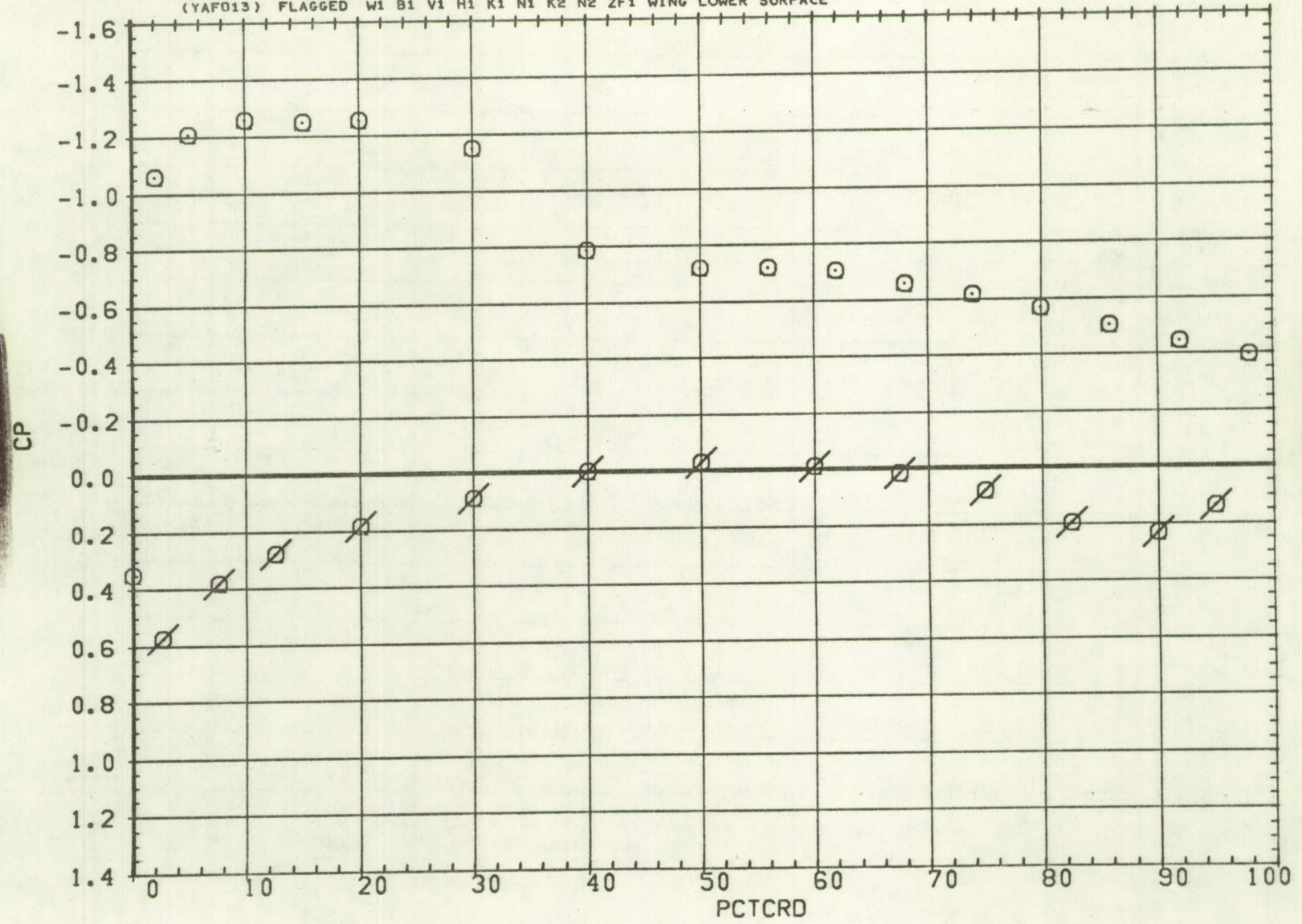

FIG. 20 WING PRESSURE DISTRIBUTION FOR FULL MODEL CONFIGURATION

SYMBOL ALPHA BL MACH
 ○ - 0.090 18.278 0.901

PARAMETRIC VALUES
 BETA 0.000 HORIZT - 1.000
 SPLR-L 0.000 TRANS 1.000
 RN/L 4.000

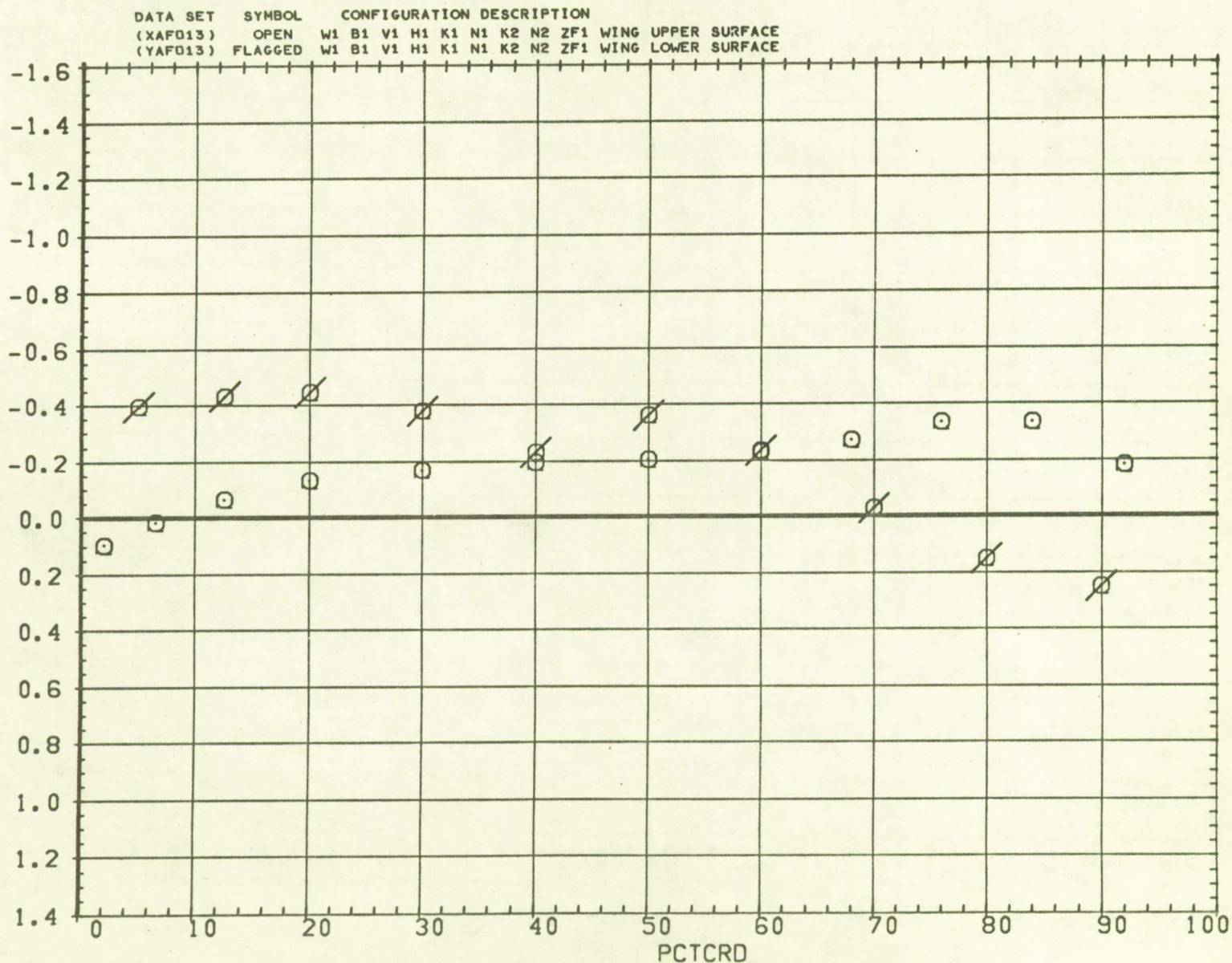

FIG. 20 WING PRESSURE DISTRIBUTION FOR FULL MODEL CONFIGURATION

SYMBOL ALPHA BL MACH
 ○ 3.460 18.278 0.901

PARAMETRIC VALUES
 BETA 0.000 HORIZT - 1.000
 SPLR-L 0.000 TRANS 1.000
 RN/L 4.000

DATA SET SYMBOL CONFIGURATION DESCRIPTION
 (XAFD13) OPEN W1 B1 V1 H1 K1 N1 K2 N2 ZF1 WING UPPER SURFACE
 (YAFD13) FLAGGED W1 B1 V1 H1 K1 N1 K2 N2 ZF1 WING LOWER SURFACE

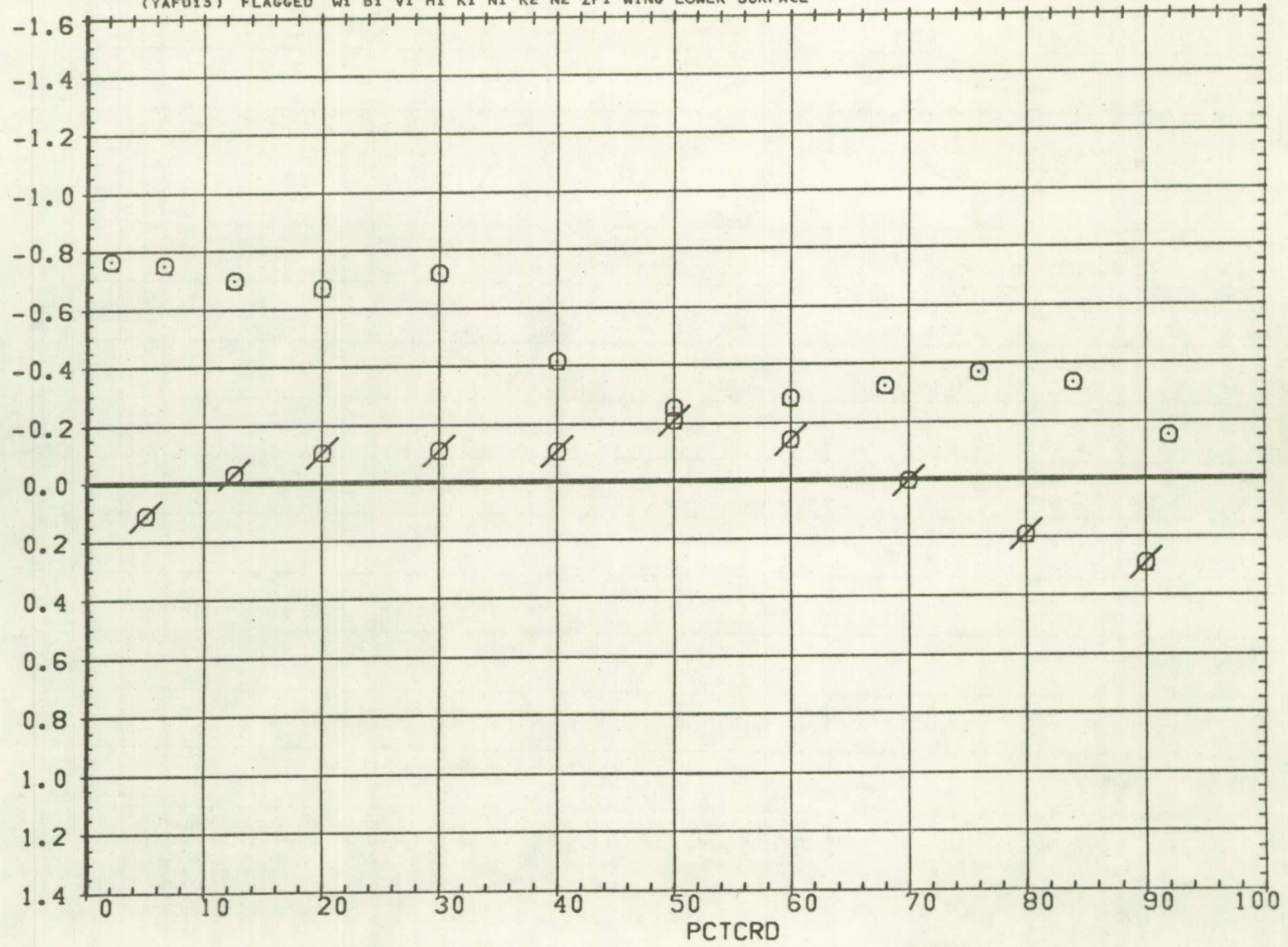

FIG. 20 WING PRESSURE DISTRIBUTION FOR FULL MODEL CONFIGURATION

SYMBOL ALPHA BL MACH
 ○ 7.890 18.278 0.901

PARAMETRIC VALUES
 BETA 0.000 HORIZT - 1.000
 SPLR-L 0.000 TRANS 1.000
 RN/L 4.000

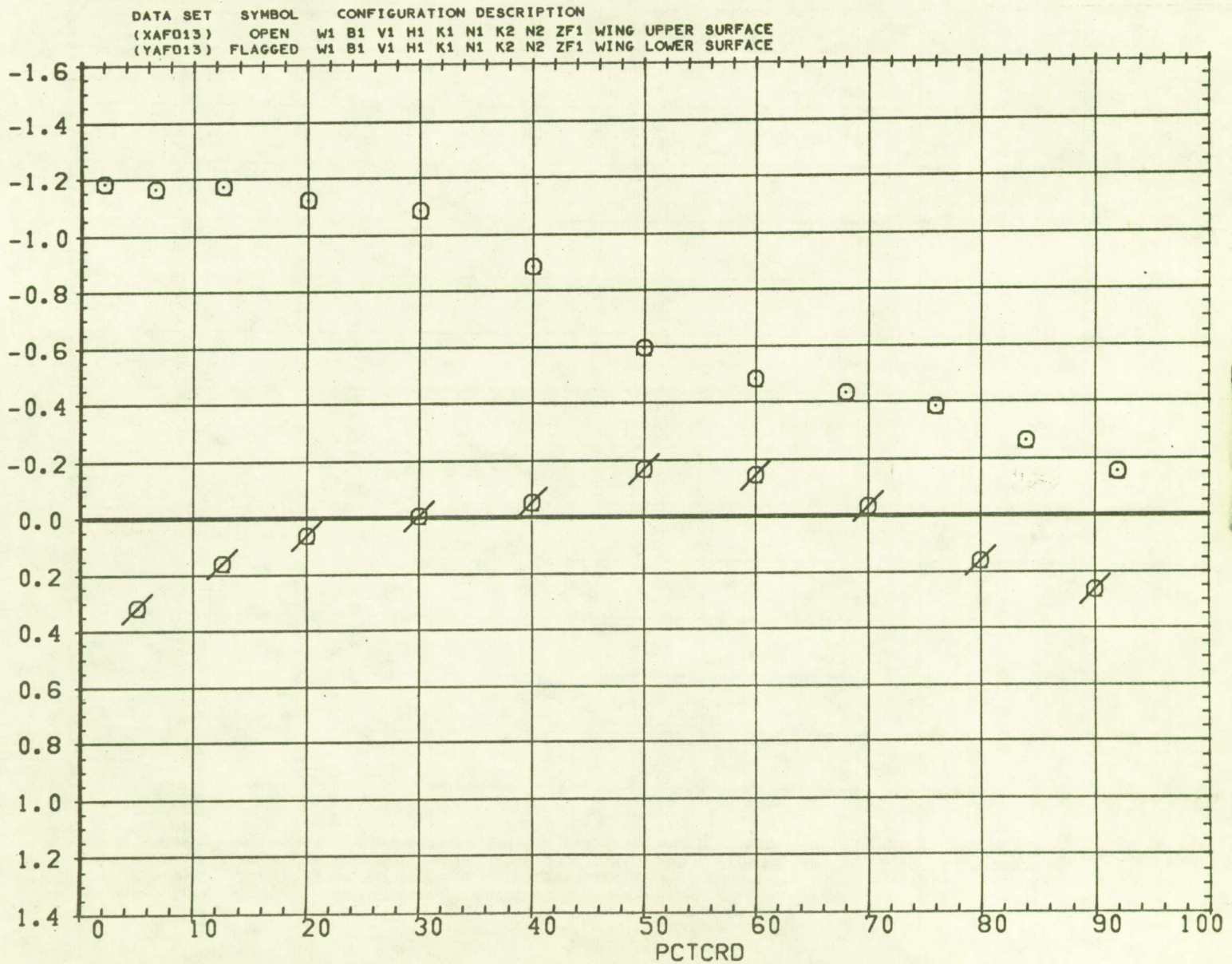

FIG. 20 WING PRESSURE DISTRIBUTION FOR FULL MODEL CONFIGURATION

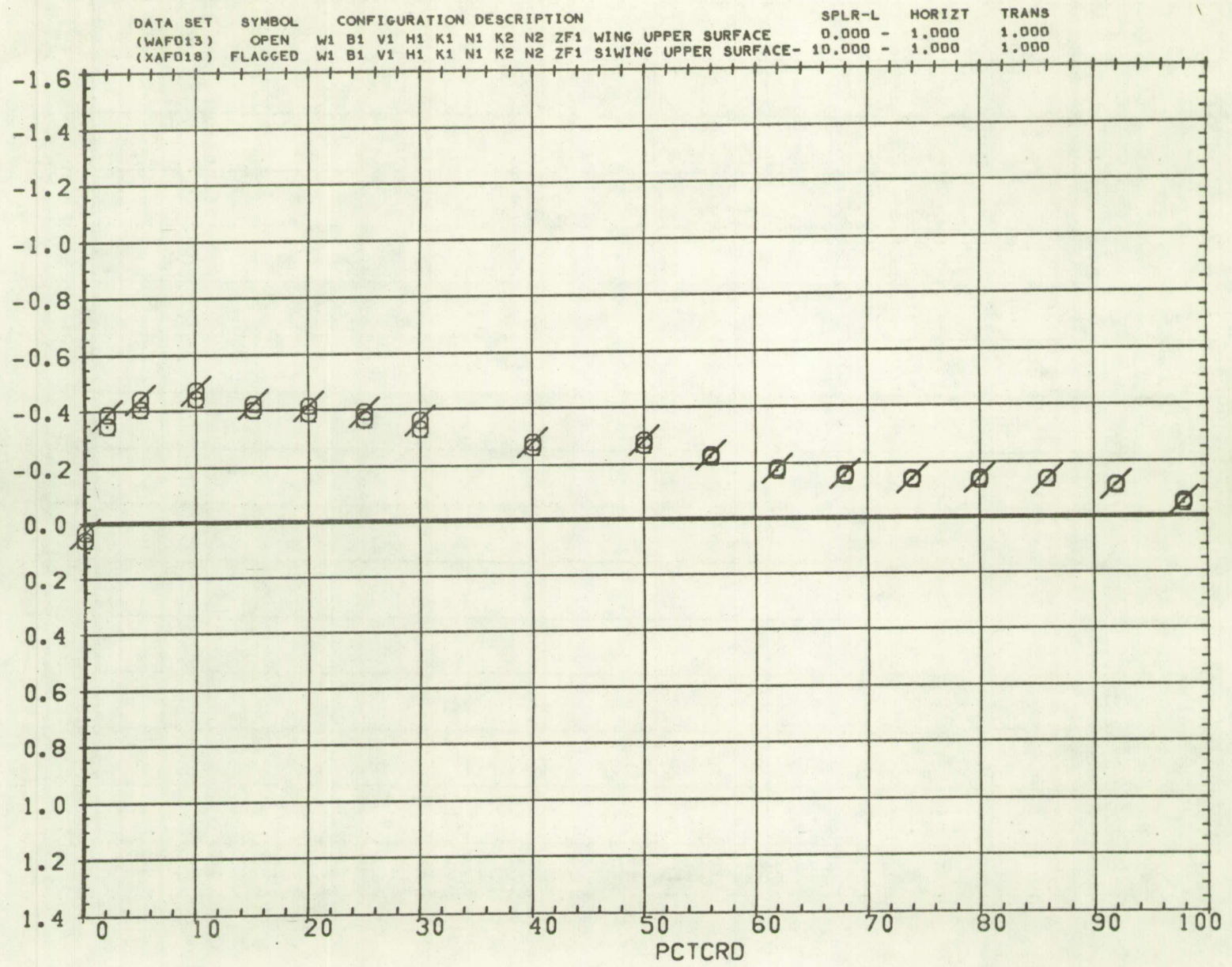

FIG. 21 EFFECT OF SPOILERS ON WING PRESSURE DIST.-WING UPPER SURFACE

SYMBOL ALPHA BL MACH
 ○ 3.440 7.768 0.800

PARAMETRIC VALUES
 BETA 0.000 RN/L 4.000

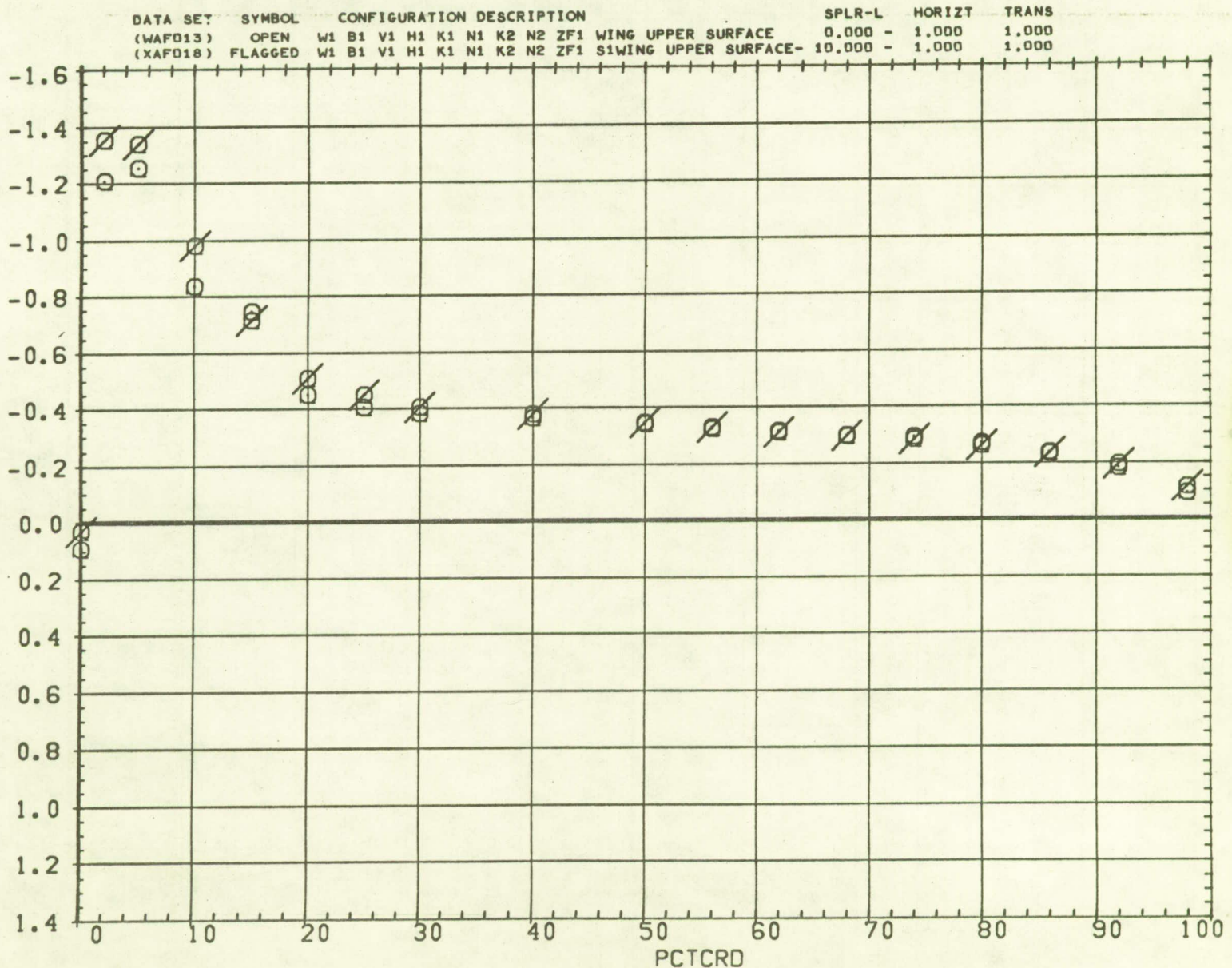

FIG. 21 EFFECT OF SPOILERS ON WING PRESSURE DIST.-WING UPPER SURFACE

DATA SET	SYMBOL	CONFIGURATION DESCRIPTION	SPLR-L	HORIZT	TRANS
(WAFD13)	OPEN	W1 B1 V1 H1 K1 N1 K2 N2 ZF1 WING UPPER SURFACE	0.000 -	1.000	1.000
(XAFD18)	FLAGGED	W1 B1 V1 H1 K1 N1 K2 N2 ZF1 S1WING UPPER SURFACE-	10.000 -	1.000	1.000

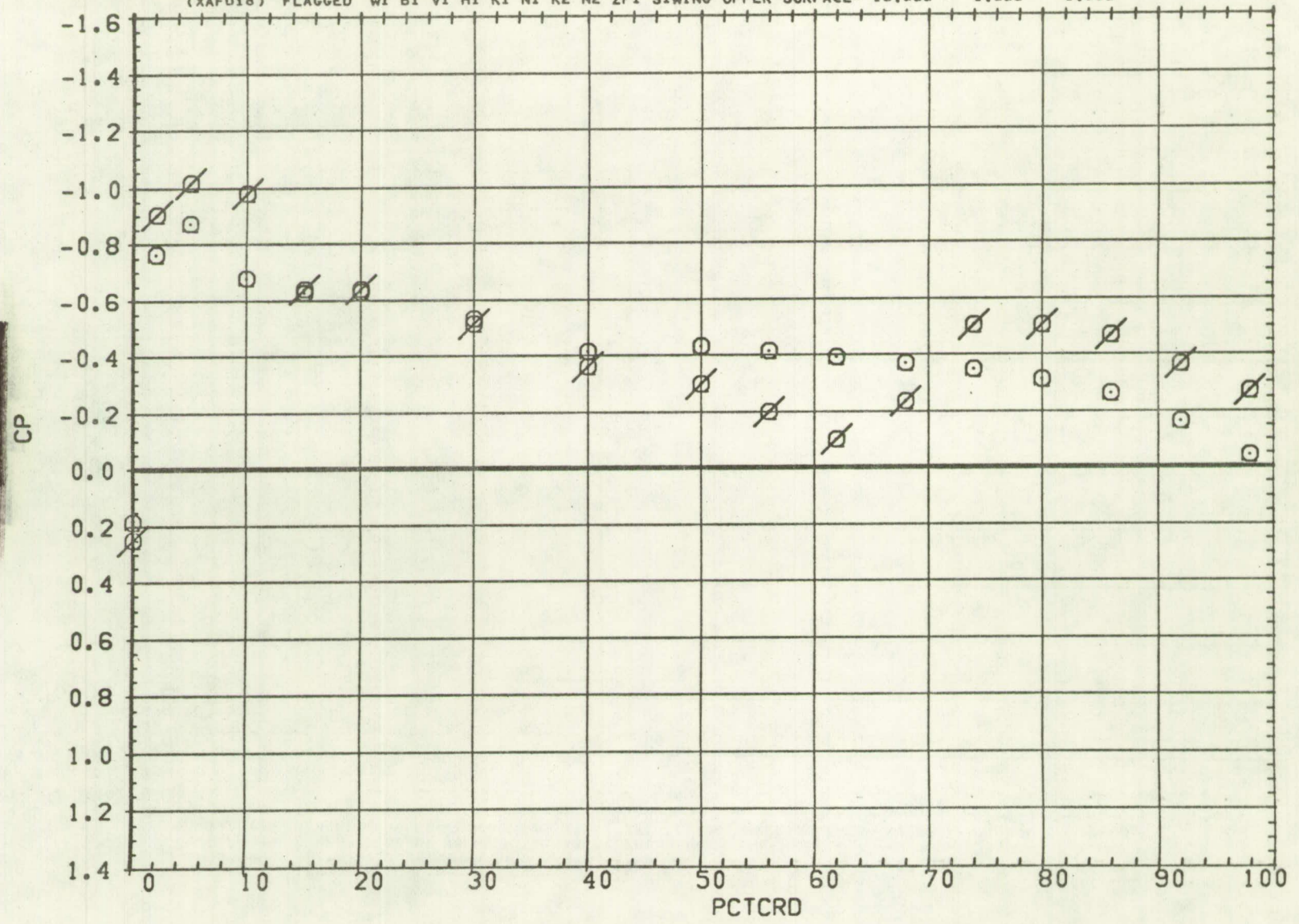

FIG. 21 EFFECT OF SPOILERS ON WING PRESSURE DIST.-WING UPPER SURFACE

SYMBOL ALPHA BL MACH
 ○ 3.440 18.278 0.800

PARAMETRIC VALUES
 BETA 0.000 RN/L 4.000

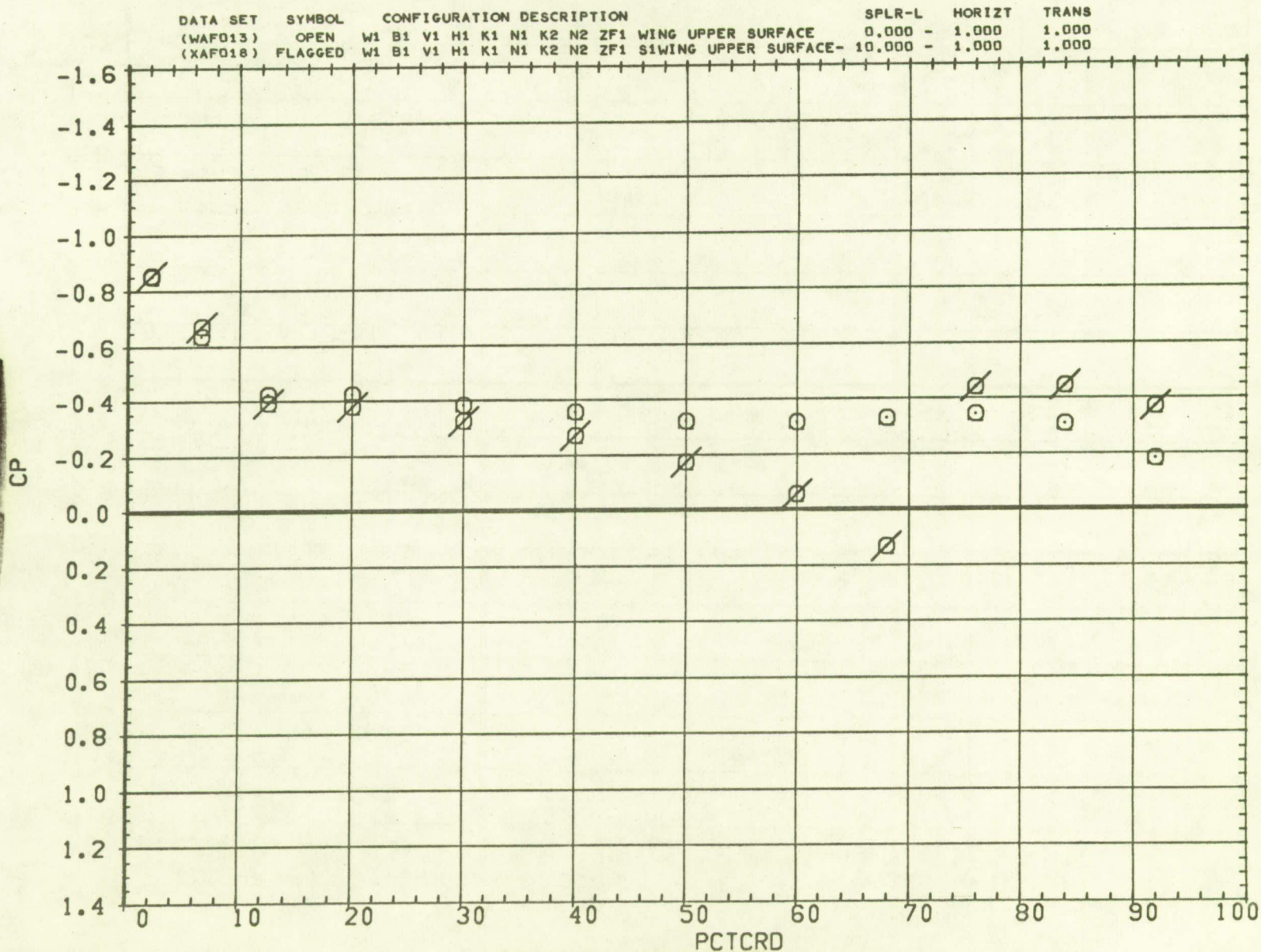

FIG. 21 EFFECT OF SPOILERS ON WING PRESSURE DIST.-WING UPPER SURFACE

DATA SET	SYMBOL	CONFIGURATION DESCRIPTION	SPLR-L	HORIZT	TRANS
(WAF013)	OPEN	W1 B1 V1 H1 K1 N1 K2 N2 ZF1 WING UPPER SURFACE	0.000 -	1.000	1.000
(XAF018)	FLAGGED	W1 B1 V1 H1 K1 N1 K2 N2 ZF1 S1WING UPPER SURFACE-	10.000 -	1.000	1.000

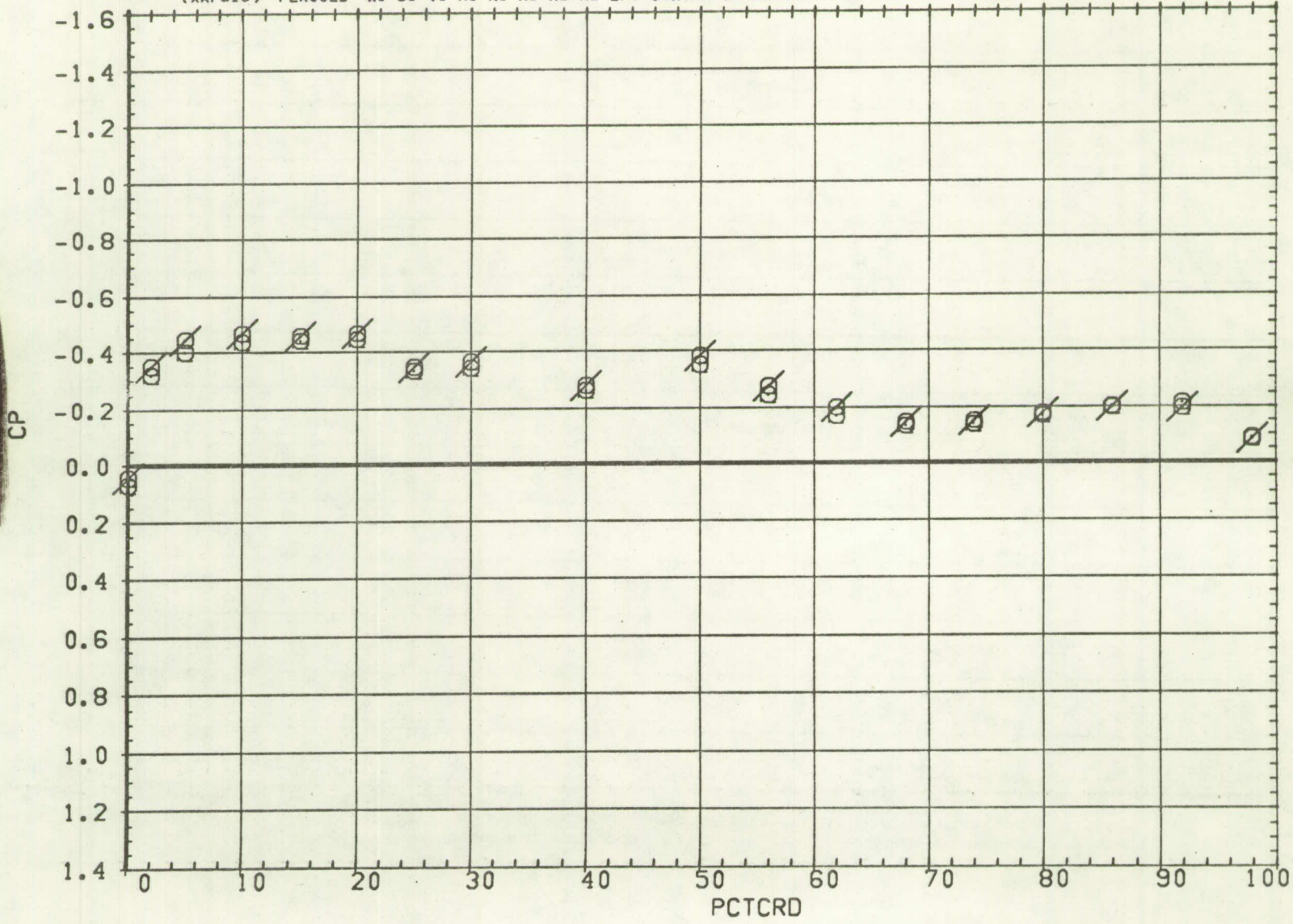

FIG. 21 EFFECT OF SPOILERS ON WING PRESSURE DIST.-WING UPPER SURFACE

SYMBOL ALPHA BL MACH
 ○ 3.460 7.768 0.902

BETA PARAMETRIC VALUES
 0.000 RN/L 4.000

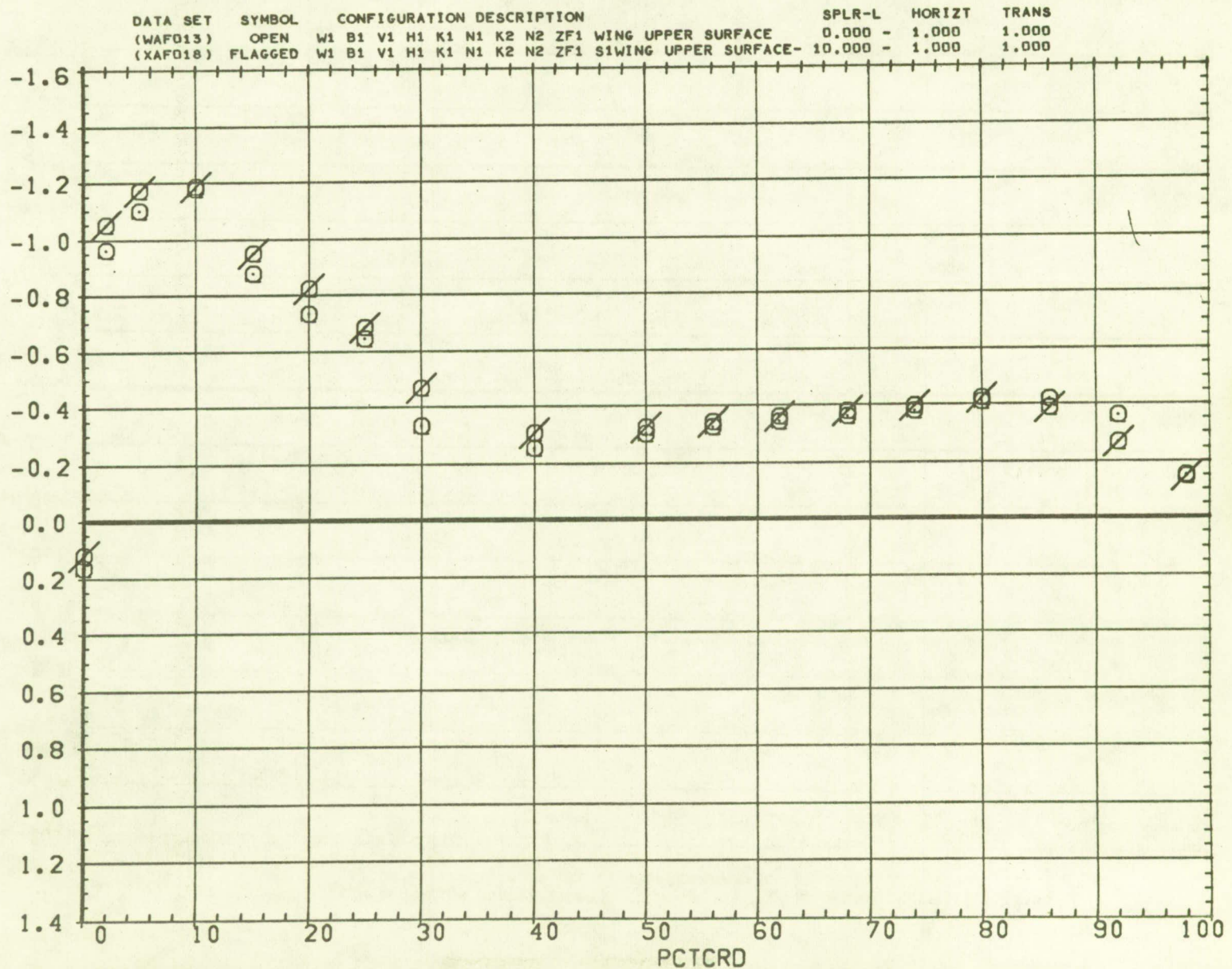

FIG. 21 EFFECT OF SPOILERS ON WING PRESSURE DIST.-WING UPPER SURFACE

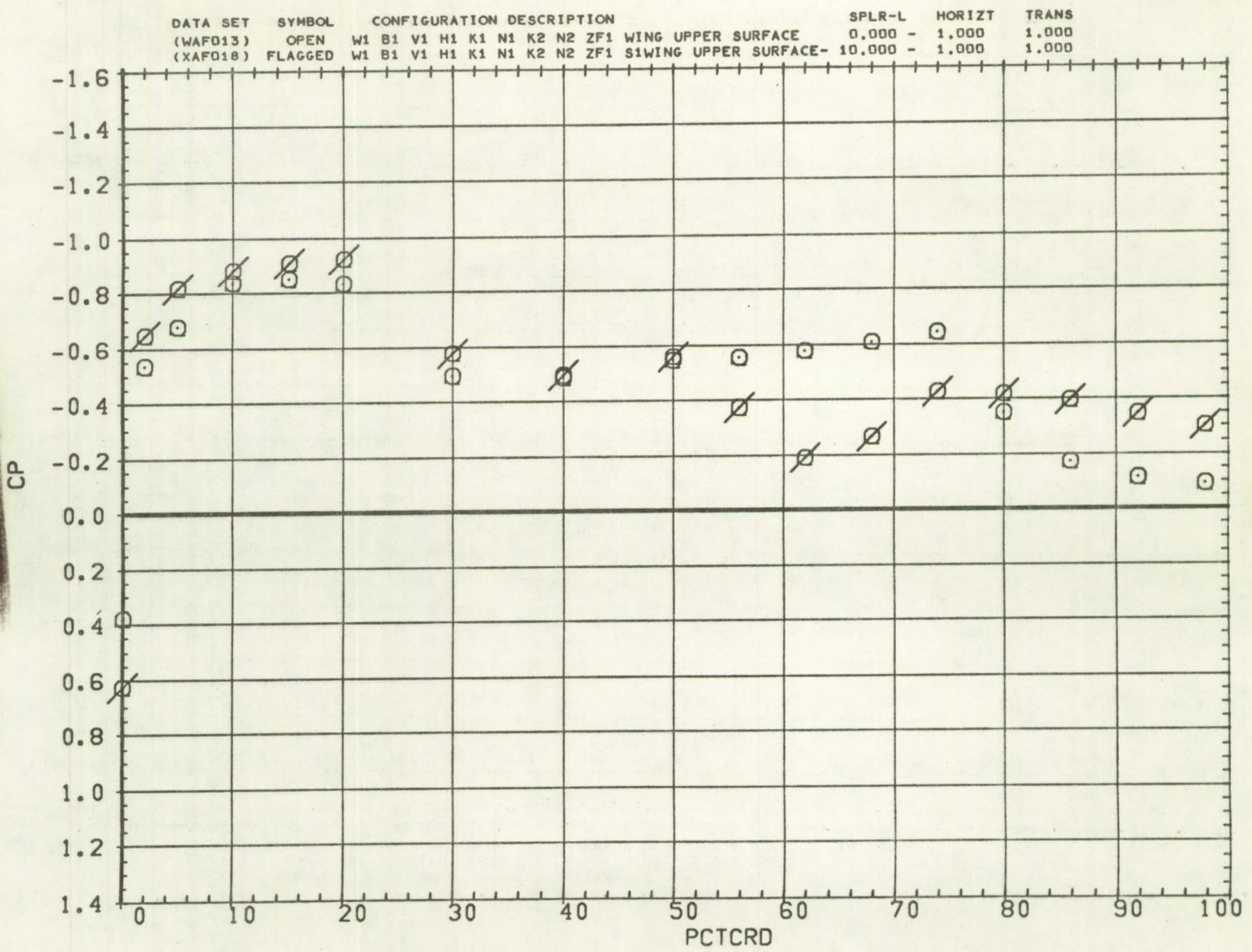

FIG. 21 EFFECT OF SPOILERS ON WING PRESSURE DIST.-WING UPPER SURFACE

SYMBOL ALPHA BL MACH
 ○ 3.460 18.278 0.902

BETA PARAMETRIC VALUES
 0.000 RN/L 4.000

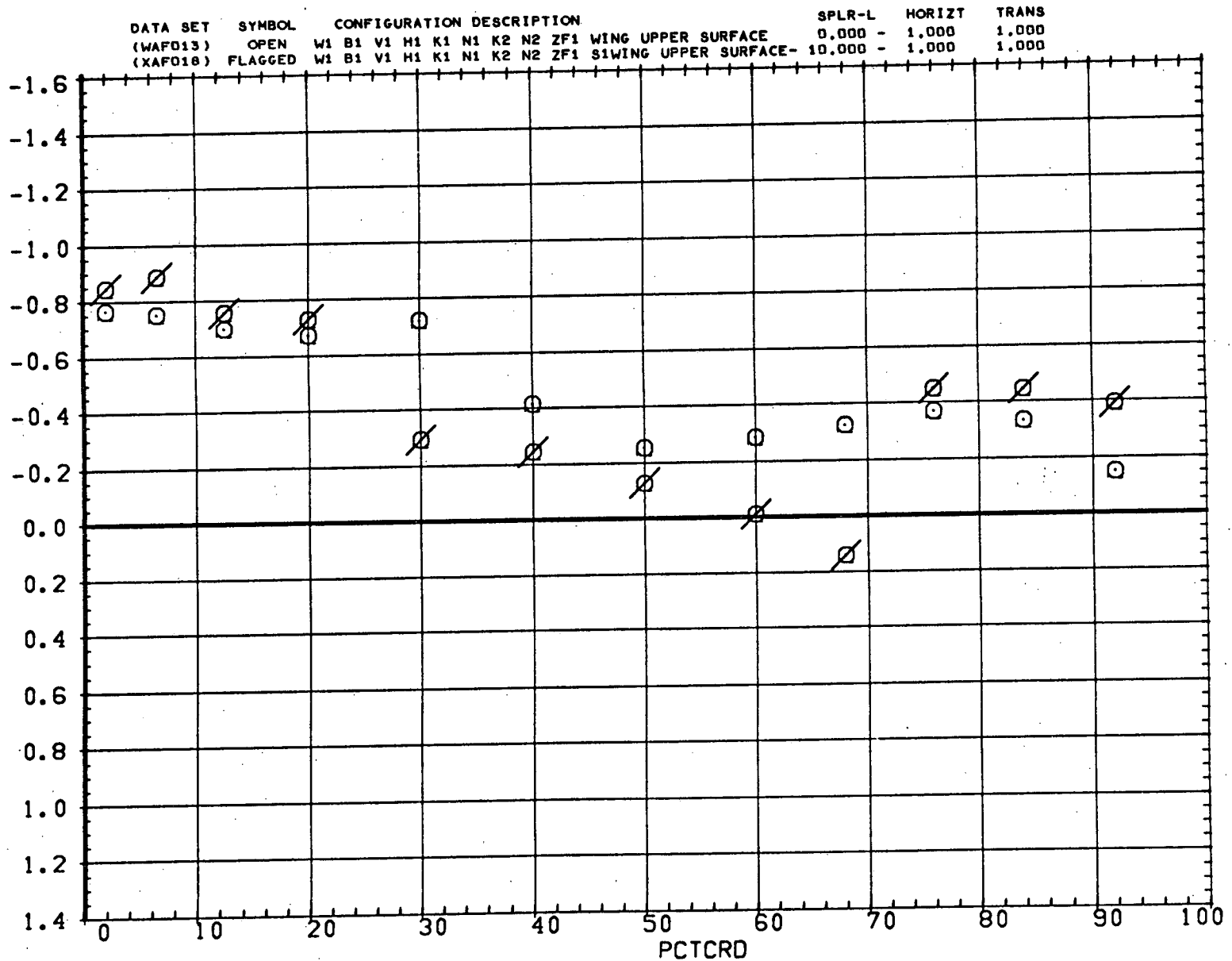

FIG. 21 EFFECT OF SPOILERS ON WING PRESSURE DIST.-WING UPPER SURFACE

SYMBOL ALPHA BL MACH
 ○ 4.000 4.250 0.800

PARAMETRIC VALUES
 BETA 0.000 RN/L 4.000

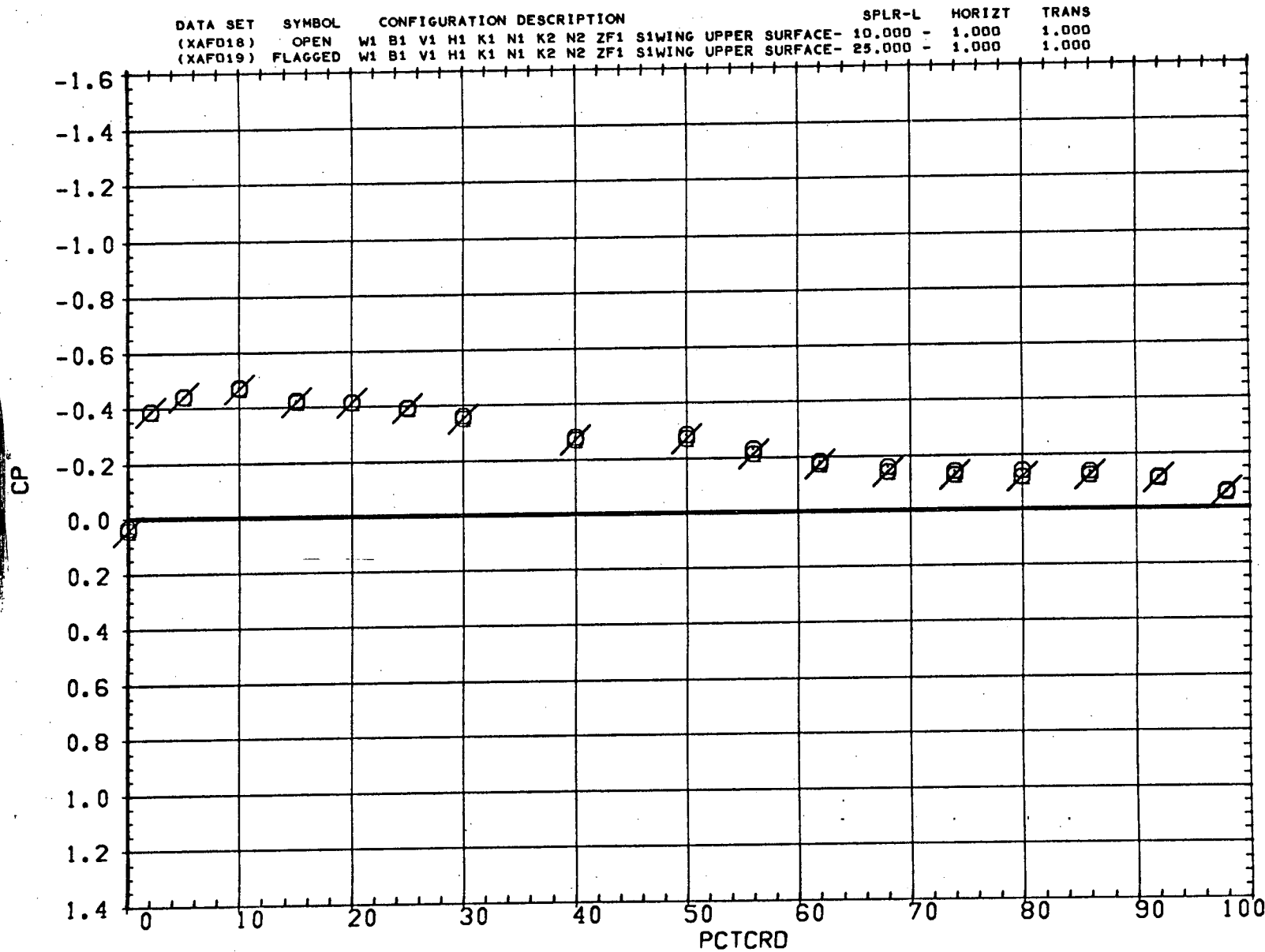

FIG. 21 EFFECT OF SPOILERS ON WING PRESSURE DIST.-WING UPPER SURFACE

SYMBOL ALPHA BL MACH
 ○ 4.000 7.768 0.800

PARAMETRIC VALUES
 BETA 0.000 RN/L 4.000

DATA SET	SYMBOL	CONFIGURATION DESCRIPTION											SPLR-L	HORIZT	TRANS
(XAFD18)	OPEN	W1	B1	V1	H1	K1	N1	K2	N2	ZF1	S1	WING UPPER SURFACE-	10.000	- 1.000	1.000
(XAFD19)	FLAGGED	W1	B1	V1	H1	K1	N1	K2	N2	ZF1	S1	WING UPPER SURFACE-	25.000	- 1.000	1.000

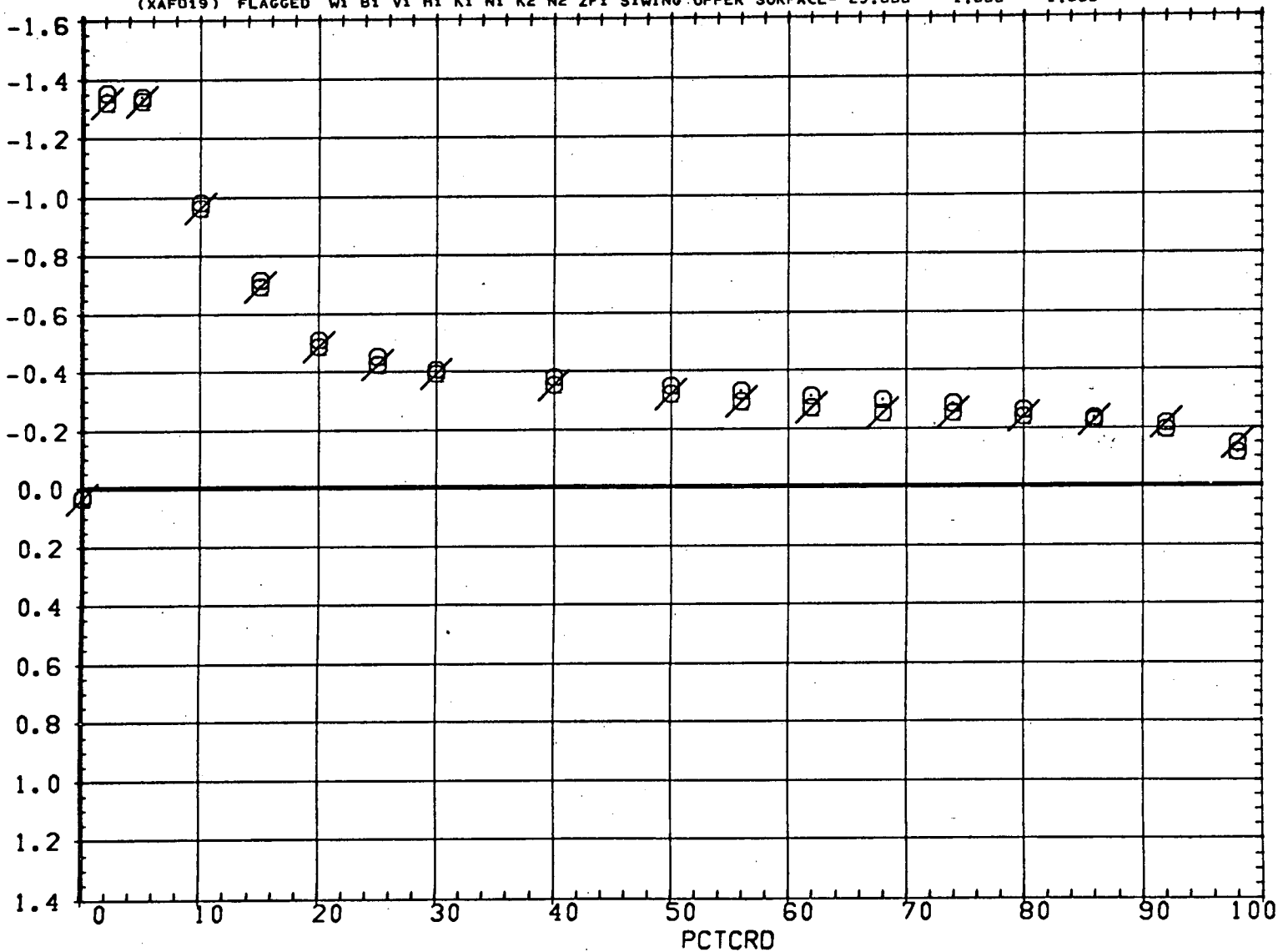

FIG. 21 EFFECT OF SPOILERS ON WING PRESSURE DIST.-WING UPPER SURFACE

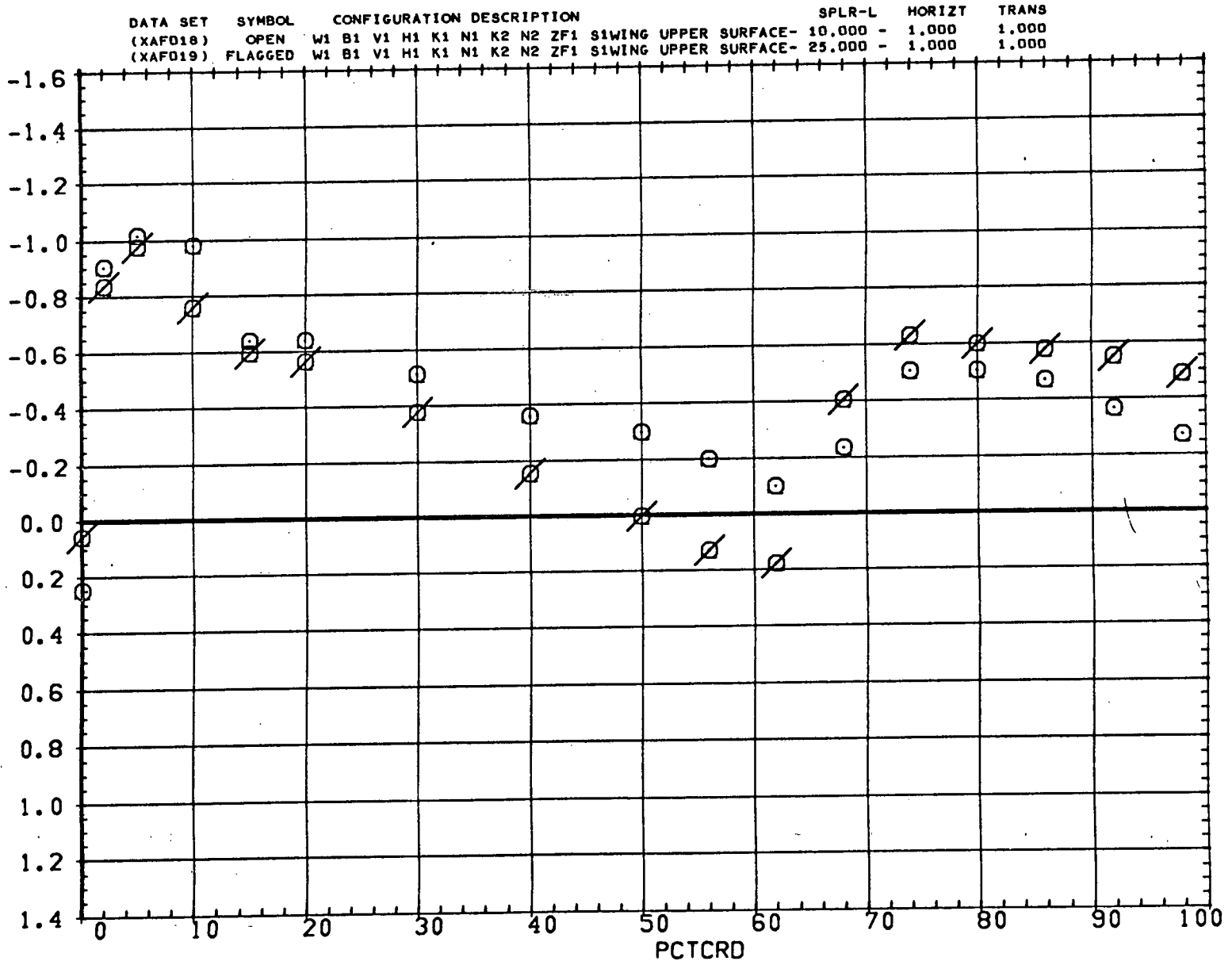
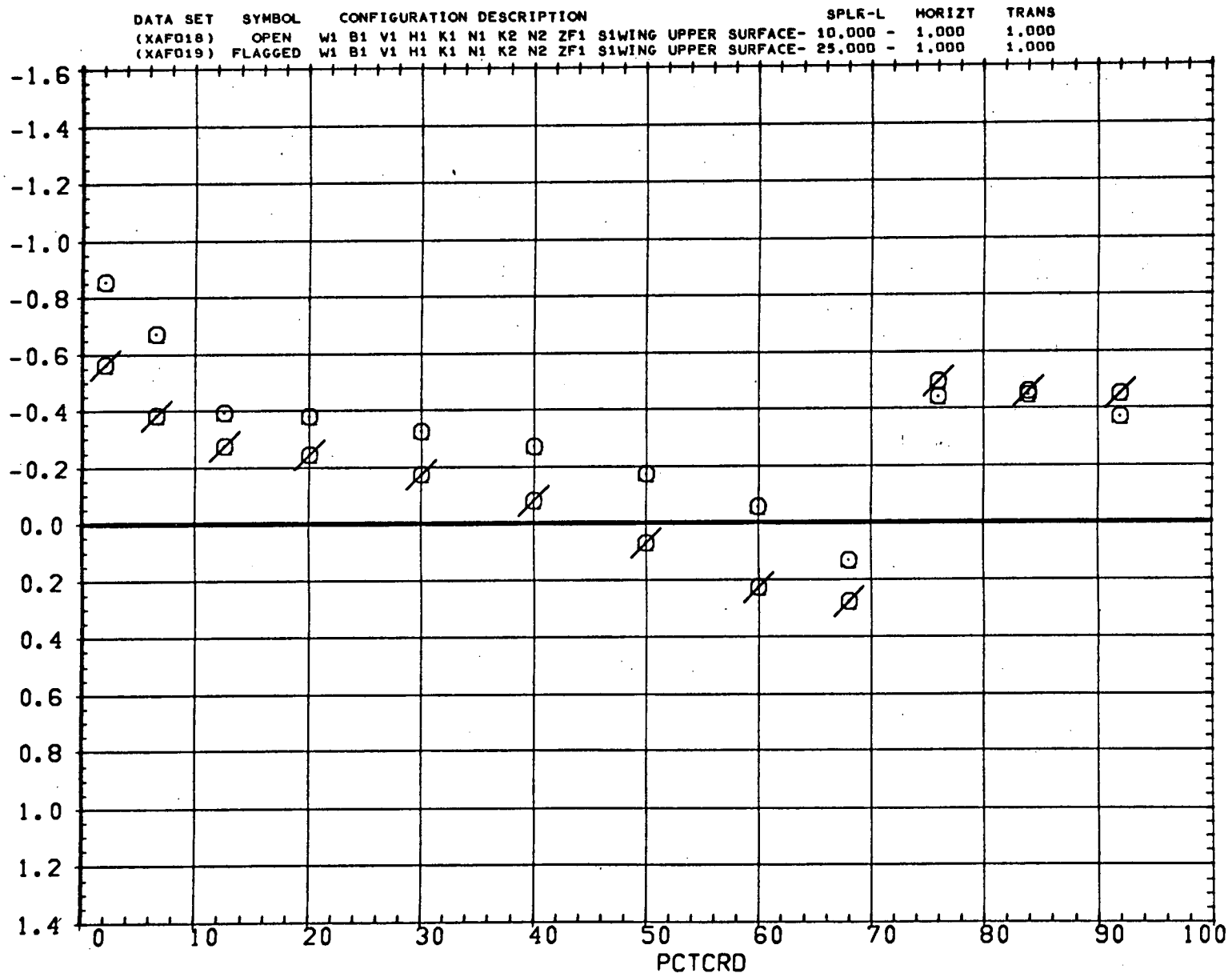

FIG. 21 EFFECT OF SPOILERS ON WING PRESSURE DIST.-WING UPPER SURFACE

SYMBOL ALPHA BL MACH
 ○ 4.000 18.278 0.800

PARAMETRIC VALUES
 BETA 0.000 RN/L 4.000



CP

FIG. 21 EFFECT OF SPOILERS ON WING PRESSURE DIST.-WING UPPER SURFACE

DATA SET	SYMBOL	CONFIGURATION DESCRIPTION	SPLR-L	HORIZT	TRANS
(XAF018)	OPEN	W1 B1 V1 H1 K1 N1 K2 N2 ZF1 S1WING UPPER SURFACE-	10.000	1.000	1.000
(XAF019)	FLAGGED	W1 B1 V1 H1 K1 N1 K2 N2 ZF1 S1WING UPPER SURFACE-	25.000	1.000	1.000

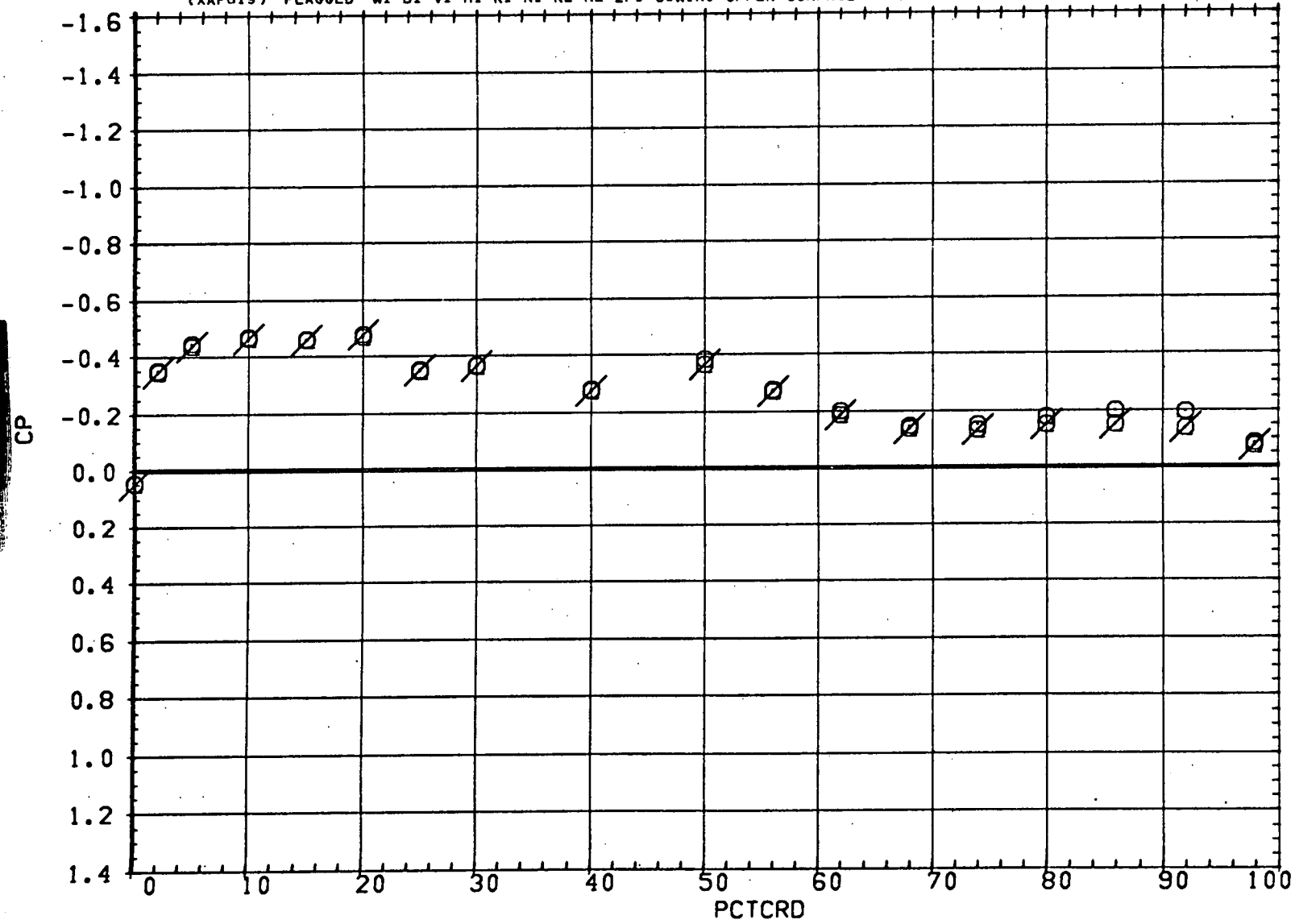

FIG. 21 EFFECT OF SPOILERS ON WING PRESSURE DIST.-WING UPPER SURFACE

SYMBOL ALPHA BL MACH
 ○ 4.000 7.768 0.902

PARAMETRIC VALUES
 BETA 0.000 RN/L 4.000

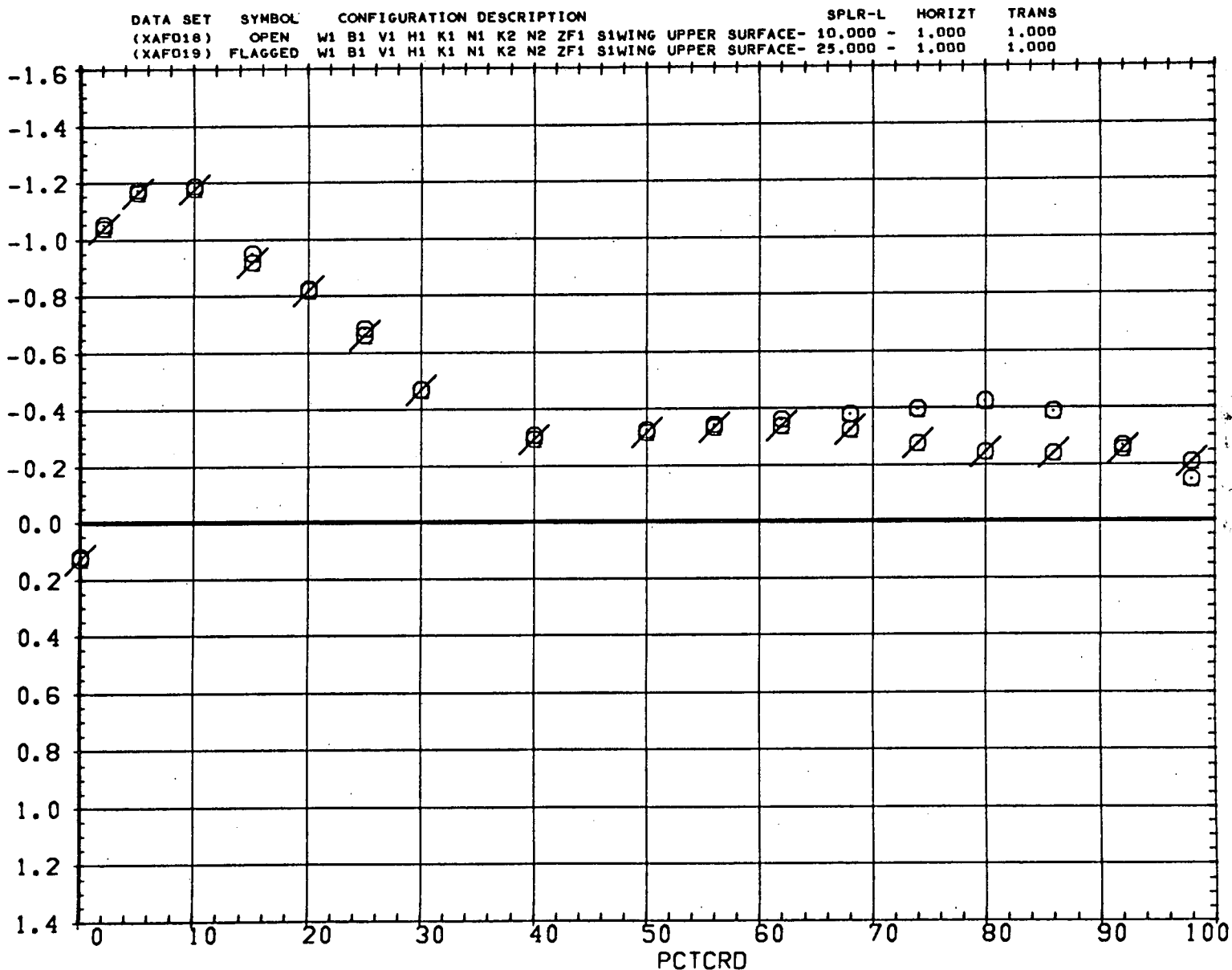

FIG. 21 EFFECT OF SPOILERS ON WING PRESSURE DIST.-WING UPPER SURFACE

SYMBOL ALPHA BL MACH
 ○ 4.000 11.424 0.902

PARAMETRIC VALUES
 BETA 0.000 RN/L 4.000

DATA SET	SYMBOL	CONFIGURATION DESCRIPTION										SPLR-L	HORIZT	TRANS		
(XAFD18)	OPEN	W1	B1	V1	H1	K1	N1	K2	N2	ZF1	S1	WING UPPER SURFACE-	10.000	-	1.000	1.000
(XAFD19)	FLAGGED	W1	B1	V1	H1	K1	N1	K2	N2	ZF1	S1	WING UPPER SURFACE-	25.000	-	1.000	1.000

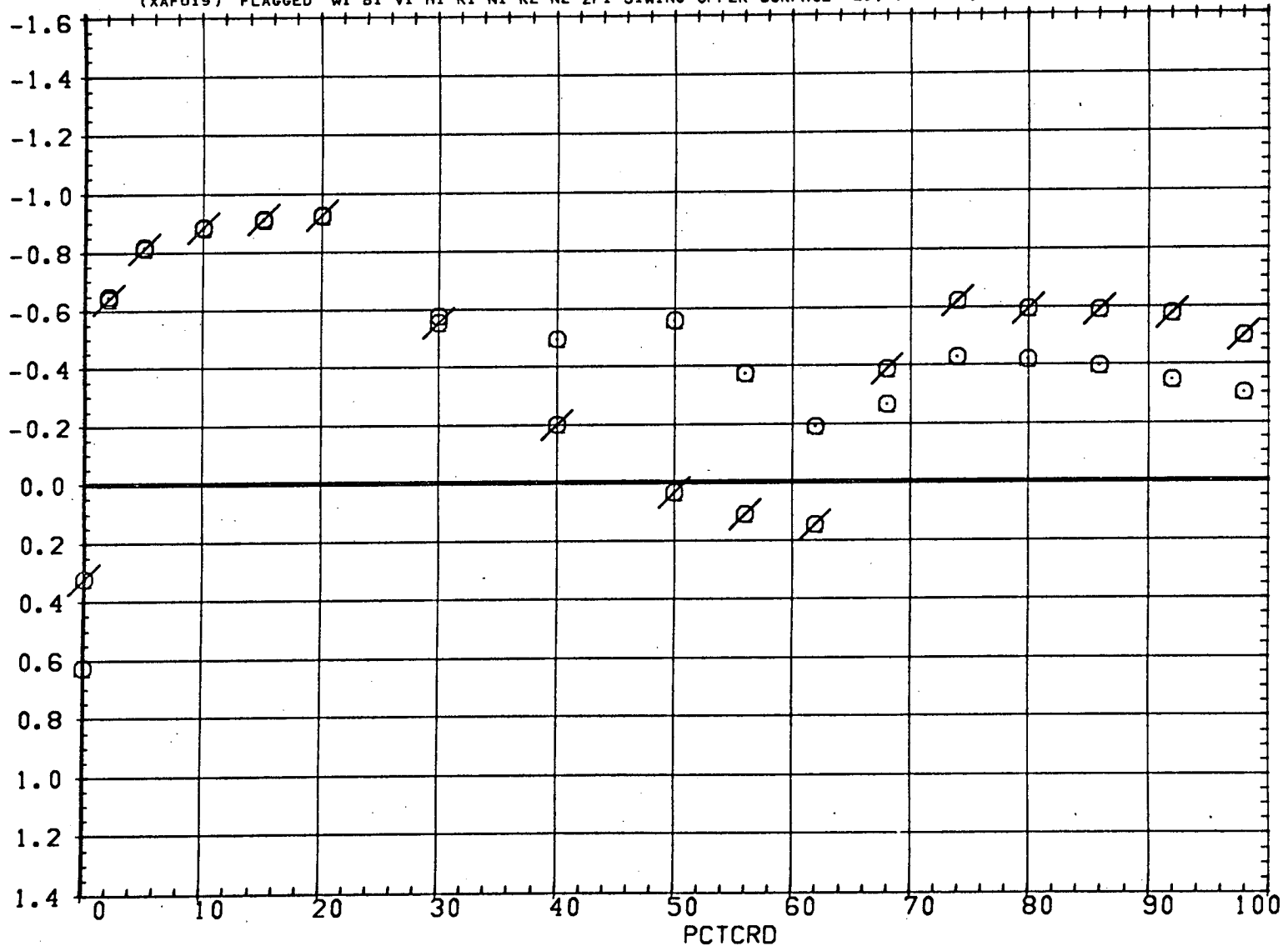

FIG. 21 EFFECT OF SPOILERS ON WING PRESSURE DIST.-WING UPPER SURFACE

SYMBOL ALPHA BL MACH
 O 4.000 18.278 0.902

BETA PARAMETRIC VALUES
 0.000 RN/L 4.000

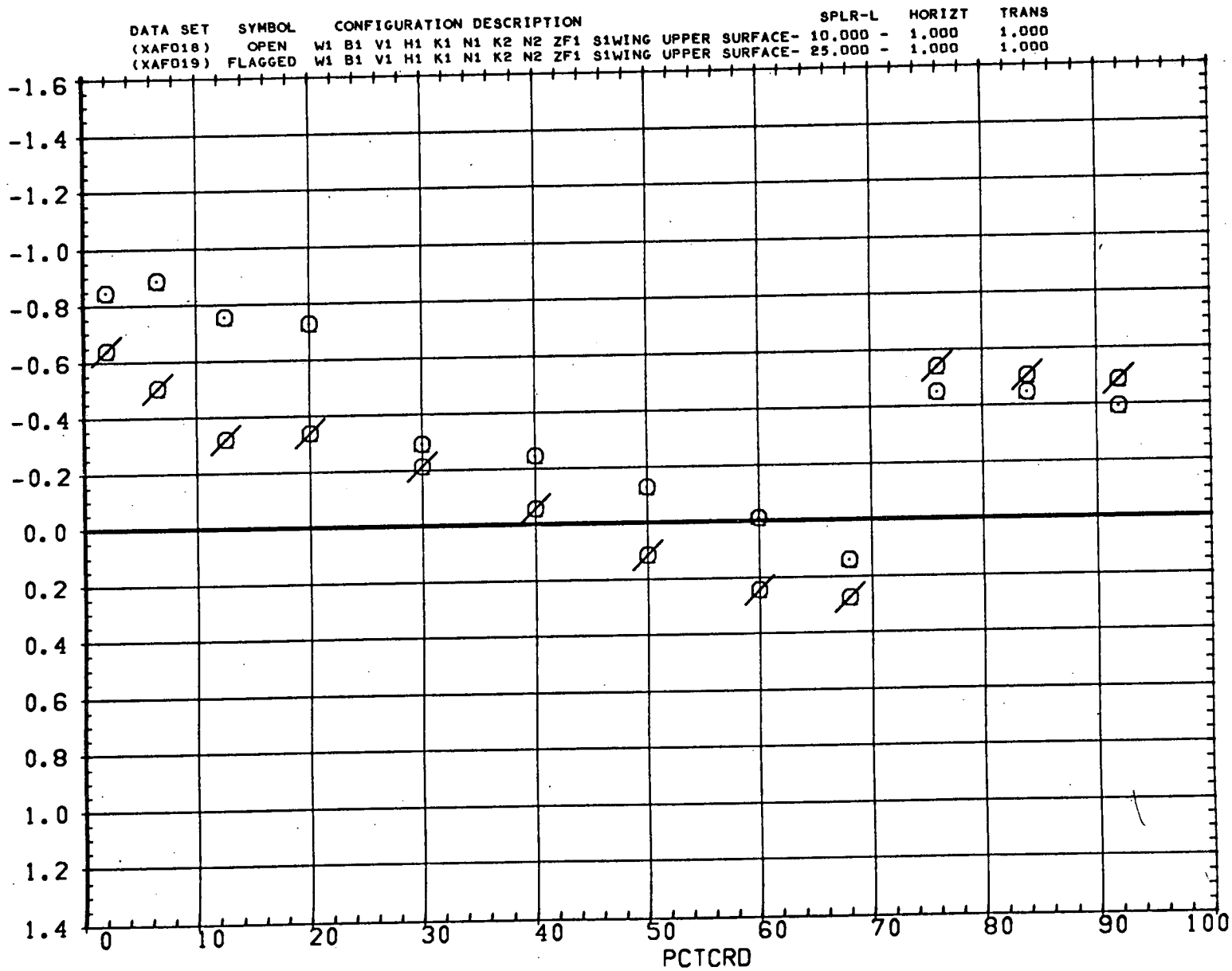

FIG. 21 EFFECT OF SPOILERS ON WING PRESSURE DIST.-WING UPPER SURFACE

DATA SET	SYMBOL	CONFIGURATION DESCRIPTION										SPLR-L	HORIZT	TRANS		
(XAFD18)	OPEN	W1	B1	V1	H1	K1	N1	K2	N2	ZF1	S1WING	UPPER SURFACE-	10.000	-	1.000	1.000
(XAFD19)	FLAGGED	W1	B1	V1	H1	K1	N1	K2	N2	ZF1	S1WING	UPPER SURFACE-	25.000	-	1.000	1.000

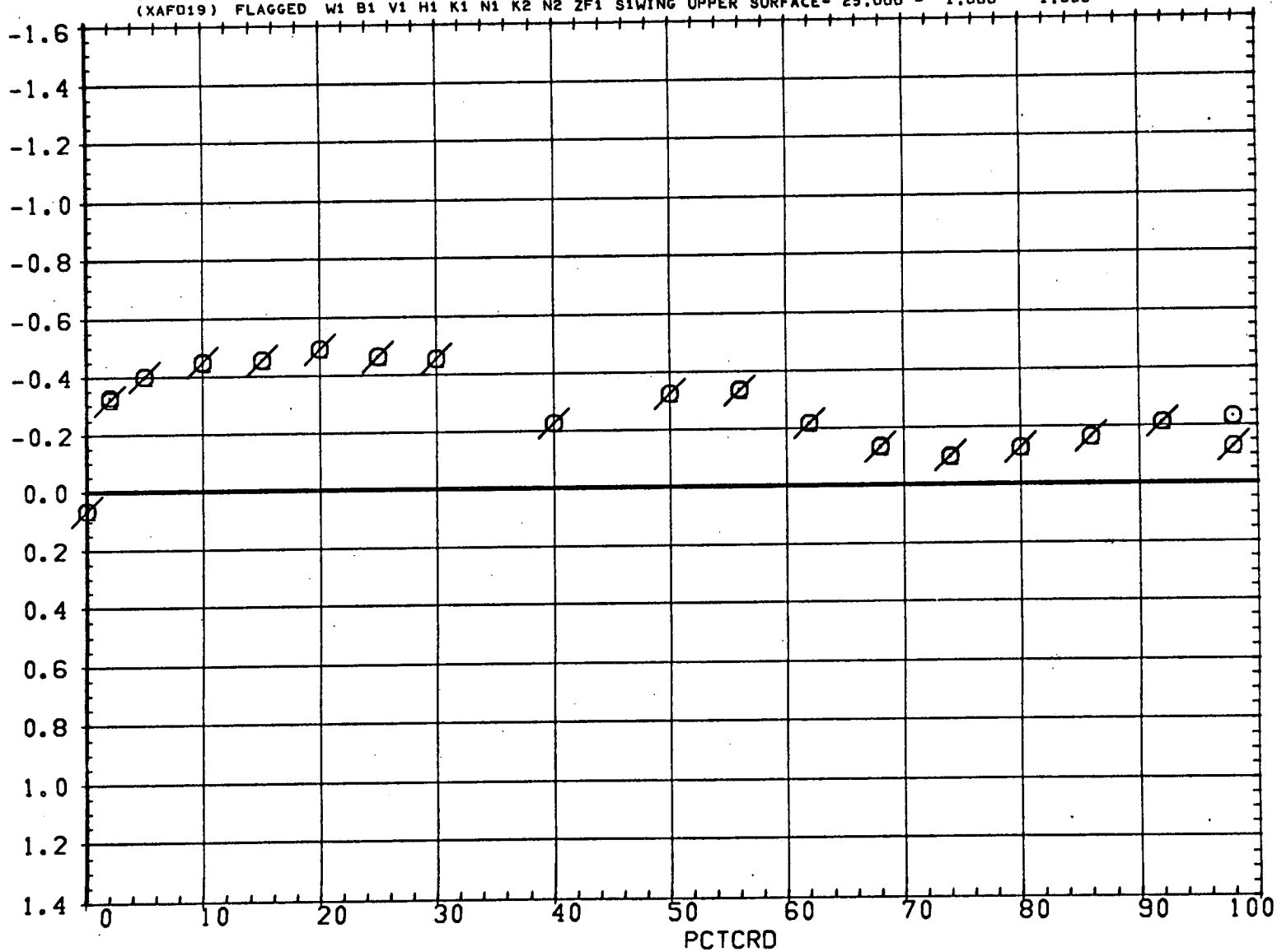

FIG. 21 EFFECT OF SPOILERS ON WING PRESSURE DIST.-WING UPPER SURFACE

SYMBOL ALPHA BL MACH
 ○ 3.980 7.768 0.949

PARAMETRIC VALUES
 BETA 0.000 RN/L 4.000

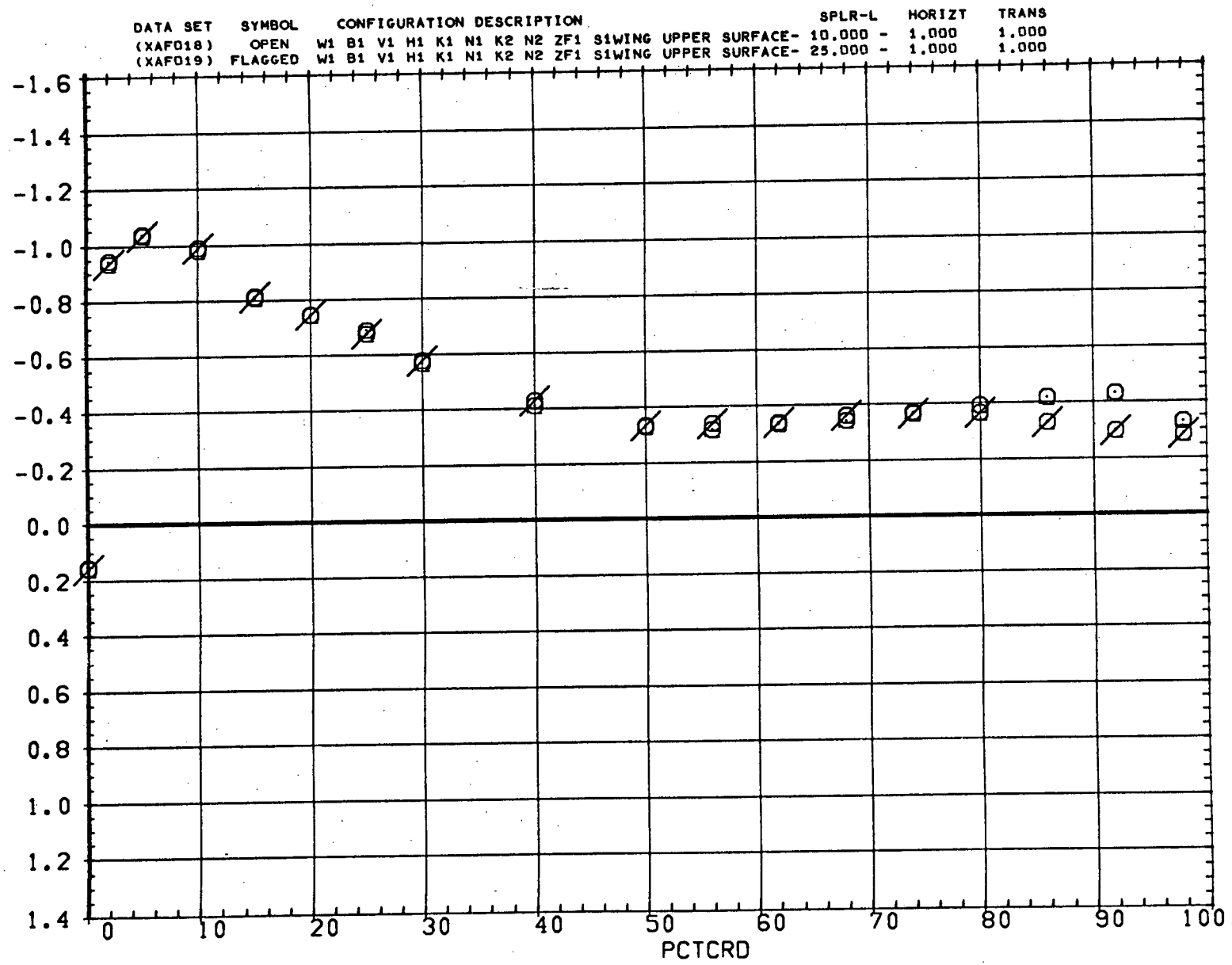

FIG. 21 EFFECT OF SPOILERS ON WING PRESSURE DIST.-WING UPPER SURFACE

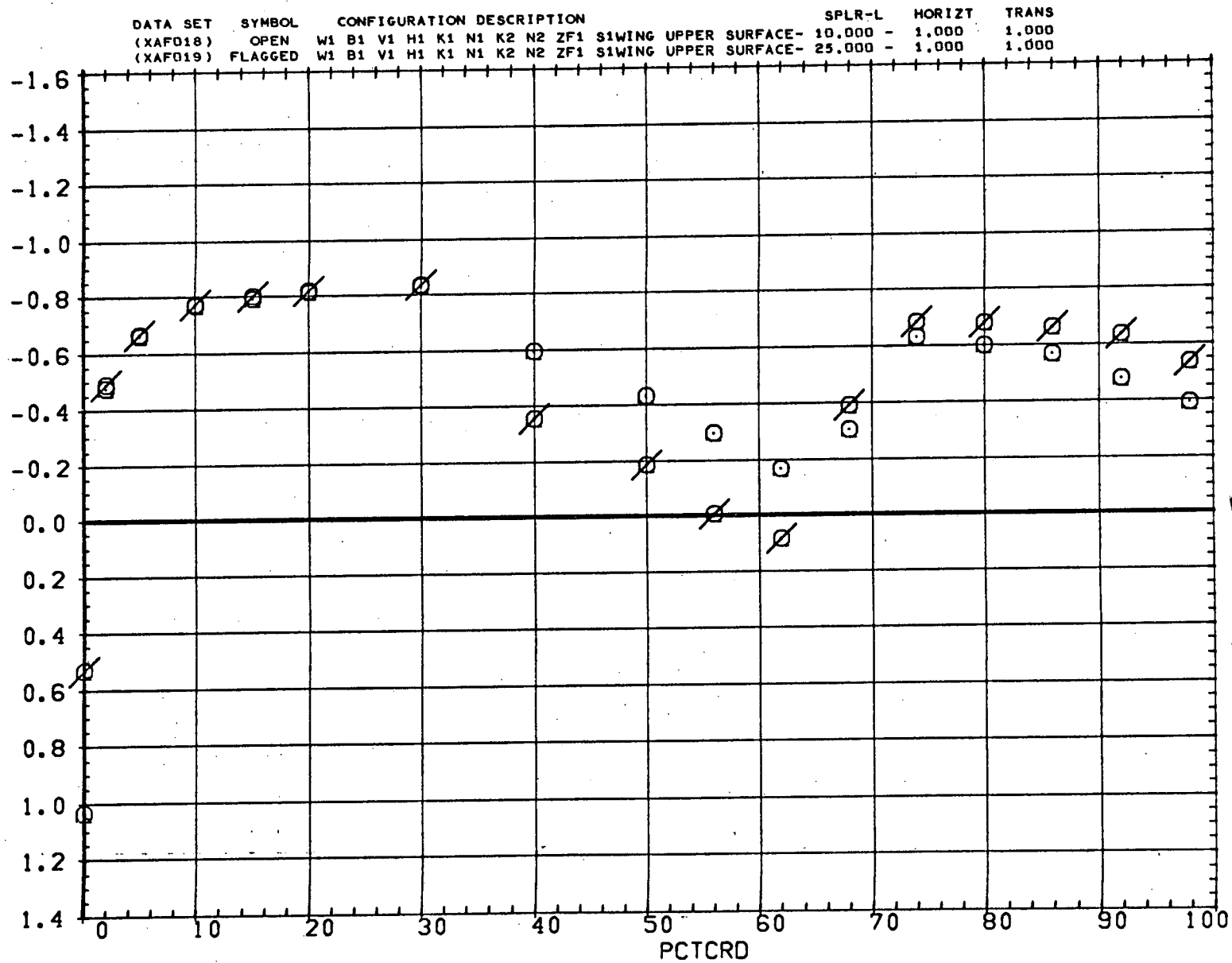

FIG. 21 EFFECT OF SPOILERS ON WING PRESSURE DIST.-WING UPPER SURFACE

SYMBOL ALPHA BL MACH
 ○ 3.980 18.278 0.949

PARAMETRIC VALUES
 BETA 0.000 RN/L 4.000

DATA SET	SYMBOL	CONFIGURATION DESCRIPTION										SPLR-L	HORIZT	TRANS		
(XAFD18)	OPEN	W1	B1	V1	H1	K1	N1	K2	N2	ZF1	S1	WING UPPER SURFACE-	10.000	-	1.000	1.000
(XAFD19)	FLAGGED	W1	B1	V1	H1	K1	N1	K2	N2	ZF1	S1	WING UPPER SURFACE-	25.000	-	1.000	1.000

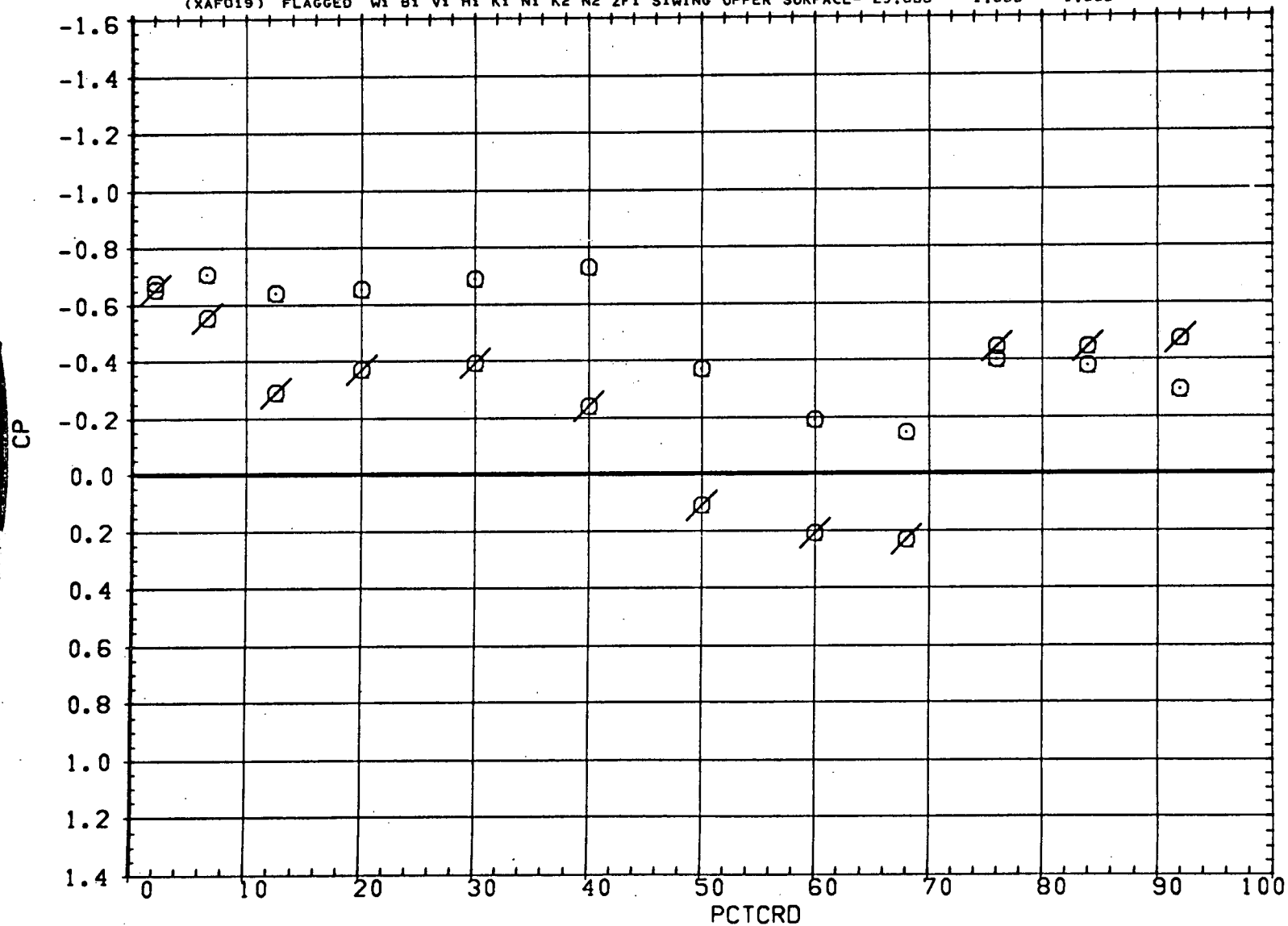

FIG. 21 EFFECT OF SPOILERS ON WING PRESSURE DIST.-WING UPPER SURFACE

SYMBOL ALPHA BL MACH
 ○ 3.440 4.250 0.800

PARAMETRIC VALUES
 BETA 0.000 RN/L 4.000

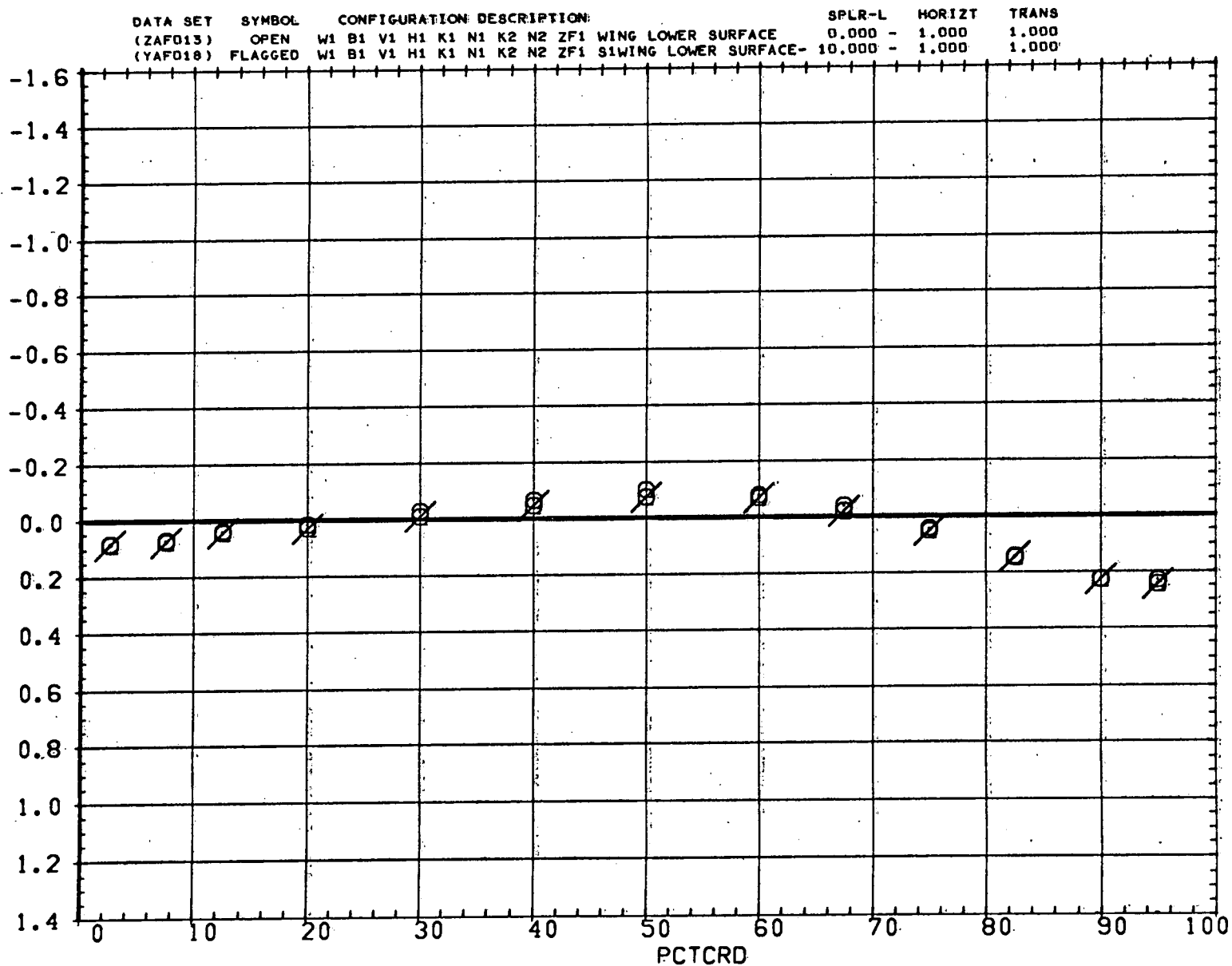

FIG. 22 EFFECT OF SPOILERS ON WING PRESSURE DIST.-WING LOWER SURFACE

SYMBOL ALPHA BL MACH
 ○ 3.440 7.768 0.800

PARAMETRIC VALUES
 BETA 0.000 RN/L 4.000

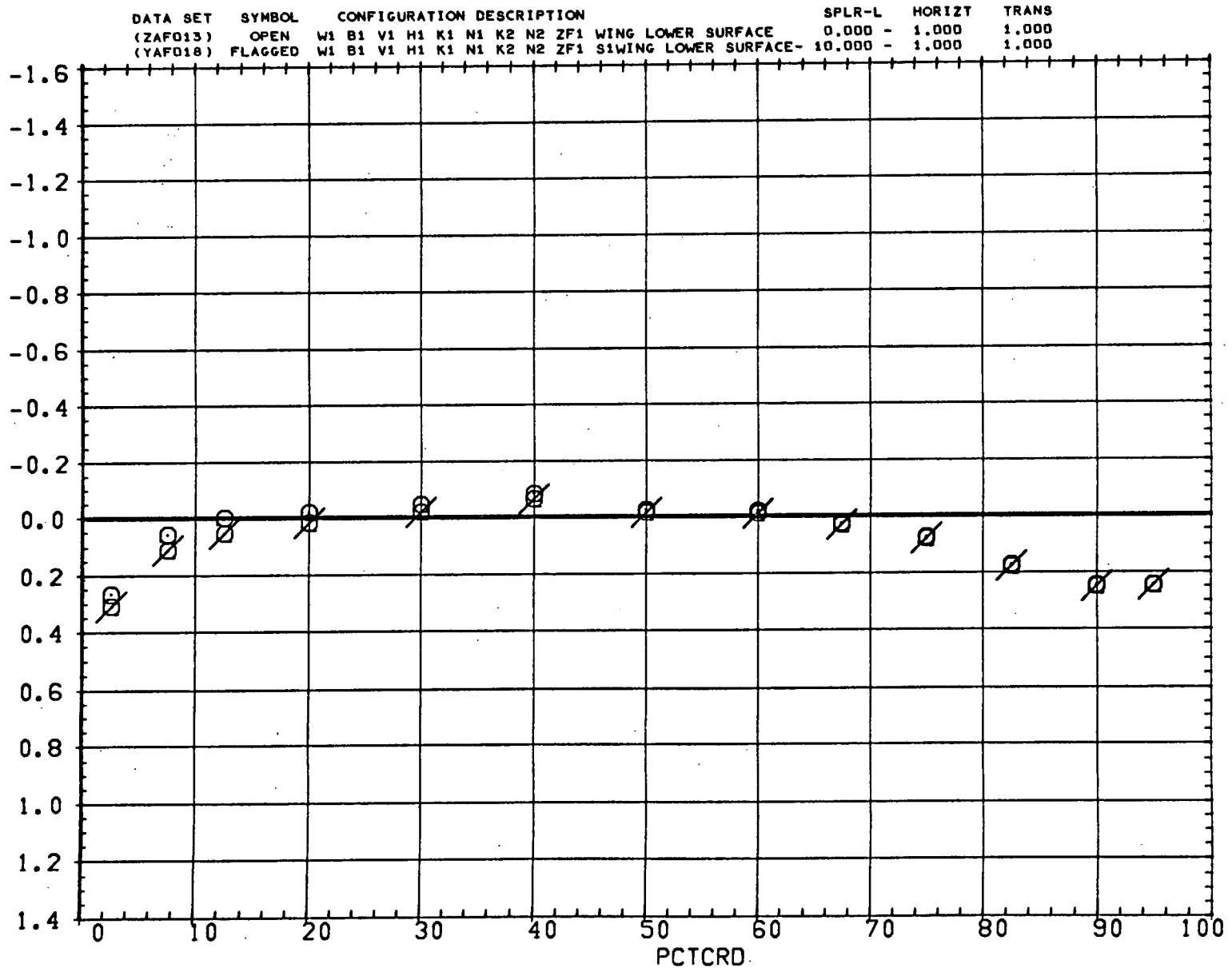

FIG. 22 EFFECT OF SPOILERS ON WING PRESSURE DIST.-WING LOWER SURFACE

DATA SET	SYMBOL	CONFIGURATION DESCRIPTION	SPLR-L	HORIZT	TRANS
(ZAFD13)	OPEN	W1 B1 V1 H1 K1 N1 K2 N2 ZF1 WING LOWER SURFACE	0.000 -	1.000	1.000
(YAFD18)	FLAGGED	W1 B1 V1 H1 K1 N1 K2 N2 ZF1 S1WING LOWER SURFACE-	10.000 -	1.000	1.000

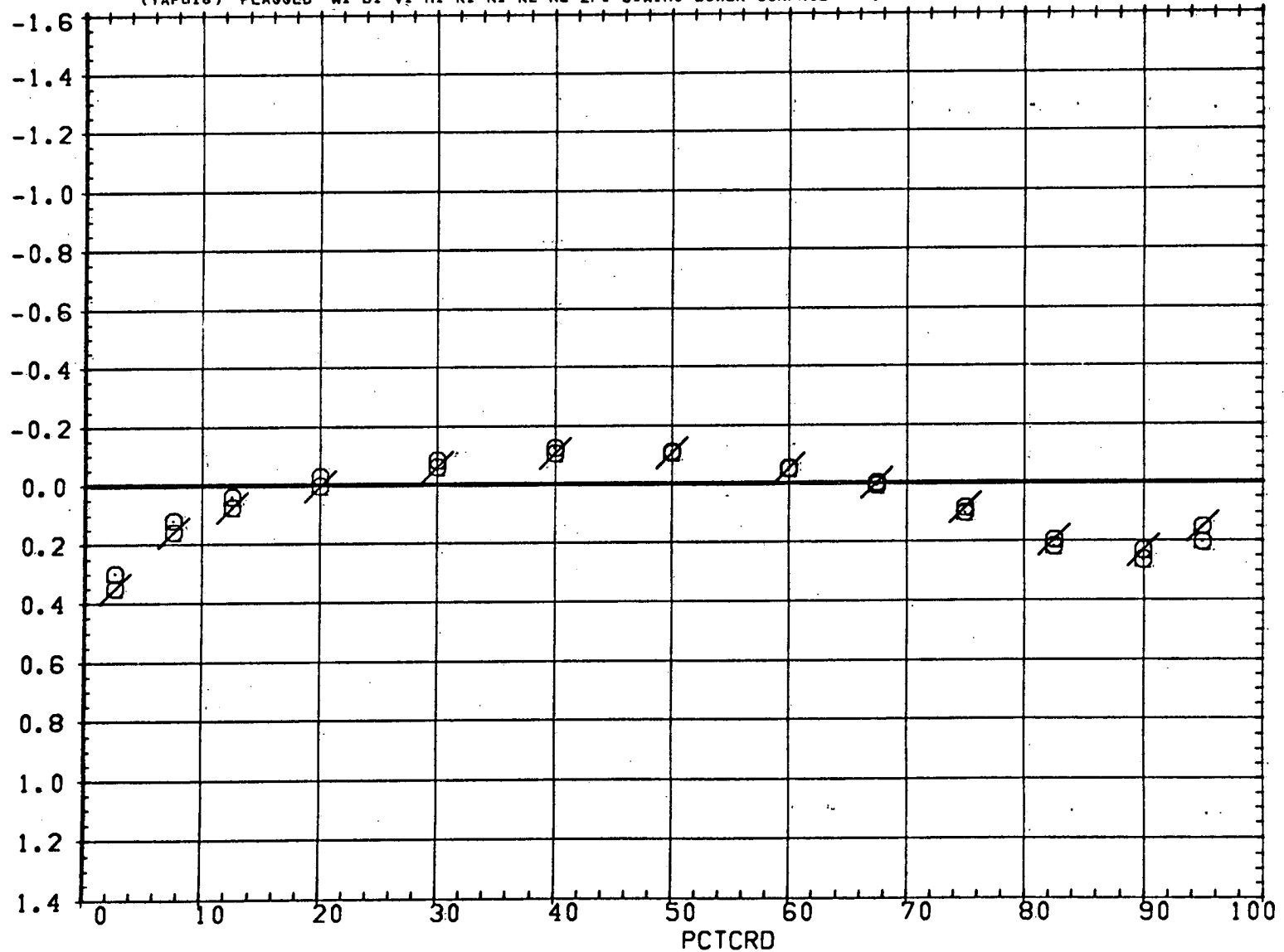

FIG. 22 EFFECT OF SPOILERS ON WING PRESSURE DIST.-WING LOWER SURFACE

SYMBOL ALPHA BL MACH
 ○ 3.440 18.278 0.800

PARAMETRIC VALUES
 BETA 0.000 RN/L 4.000

DATA SET	SYMBOL	CONFIGURATION DESCRIPTION										SPLR-L	HORIZT	TRANS
(ZAF013)	OPEN	W1	B1	V1	H1	K1	N1	K2	N2	ZF1	WING LOWER SURFACE	0.000 -	1.000	1.000
(YAF018)	FLAGGED	W1	B1	V1	H1	K1	N1	K2	N2	ZF1	S1WING LOWER SURFACE-	10.000 -	1.000	1.000

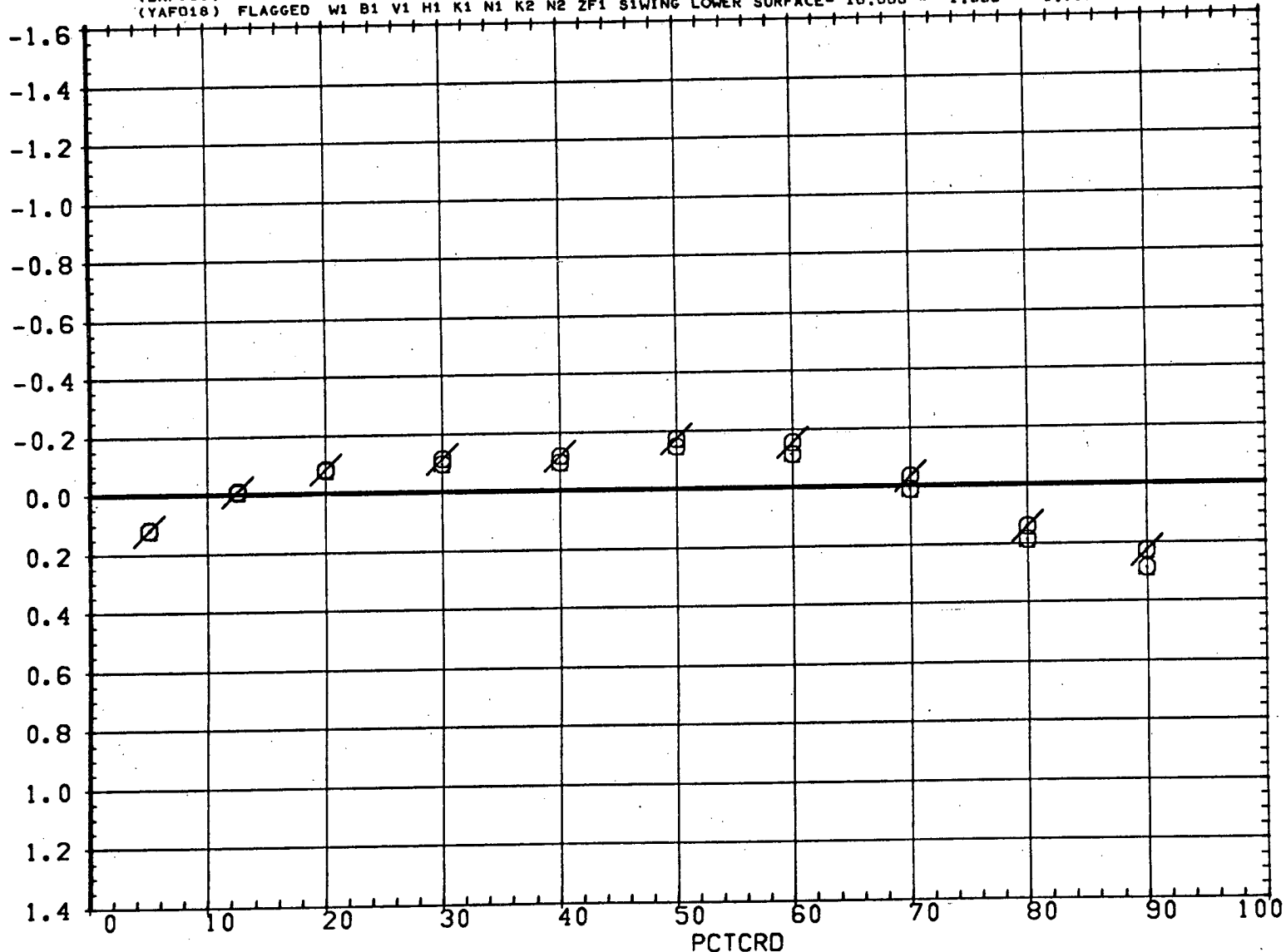

FIG. 22 EFFECT OF SPOILERS ON WING PRESSURE DIST.-WING LOWER SURFACE

DATA SET	SYMBOL	CONFIGURATION	DESCRIPTION	SPLR-L	HORIZT	TRANS.
(ZAFD13)	OPEN	W1: B1 V1 H1 K1 N1 K2 N2 ZF1	WING LOWER SURFACE	0.000 - 1.000	1.000	1.000
(YAFD18)	FLAGGED	W1: B1 V1 H1 K1 N1 K2 N2 ZF1	S1WING LOWER SURFACE	10.000 - 1.000	1.000	1.000

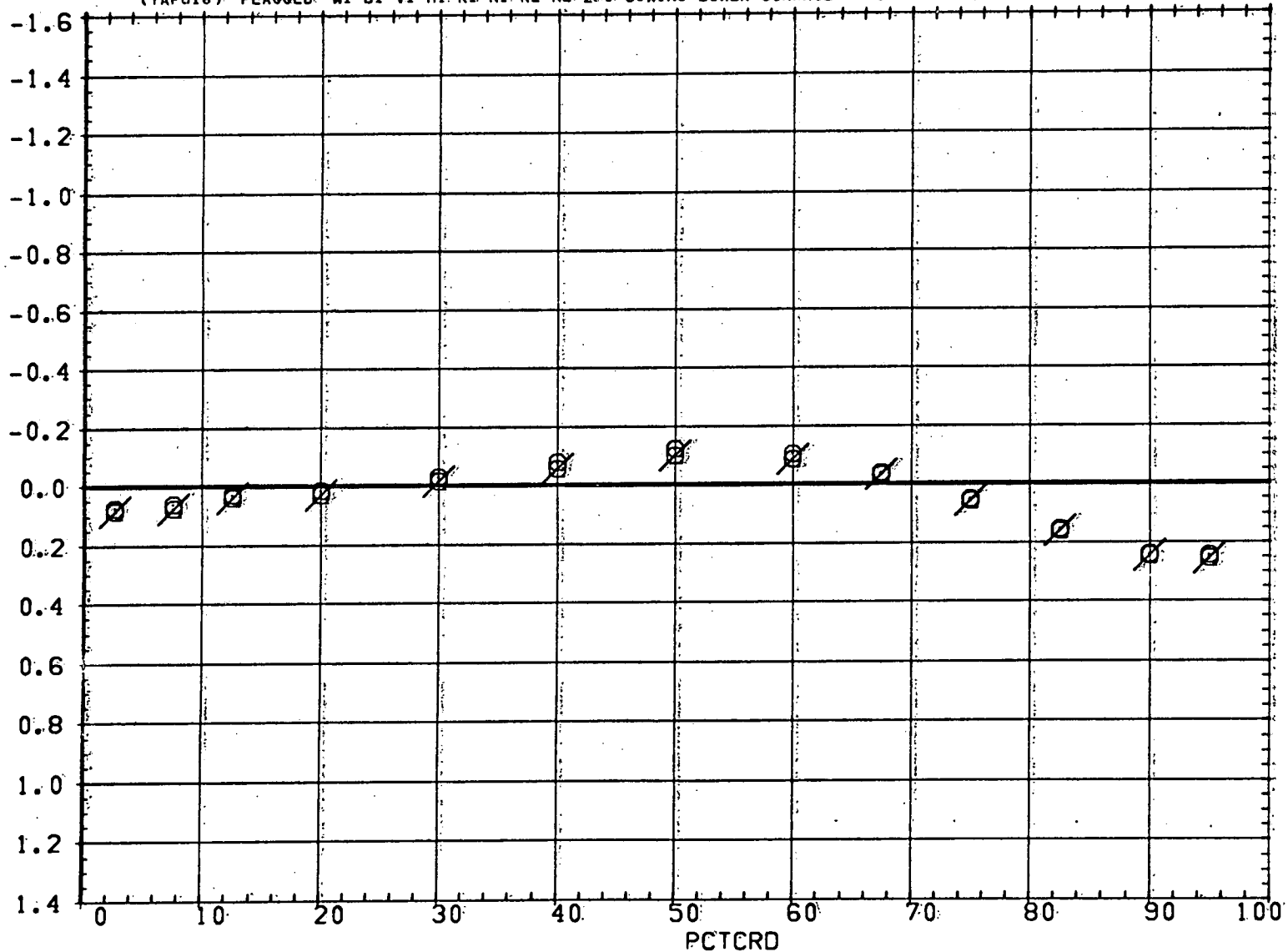

FIG. 22 EFFECT OF SPOILERS ON WING PRESSURE DIST.-WING LOWER SURFACE

SYMBOL ○ ALPHA 3.460 BL 7.768 MACH 0.902

BETA 0.000 RN/L 4.000

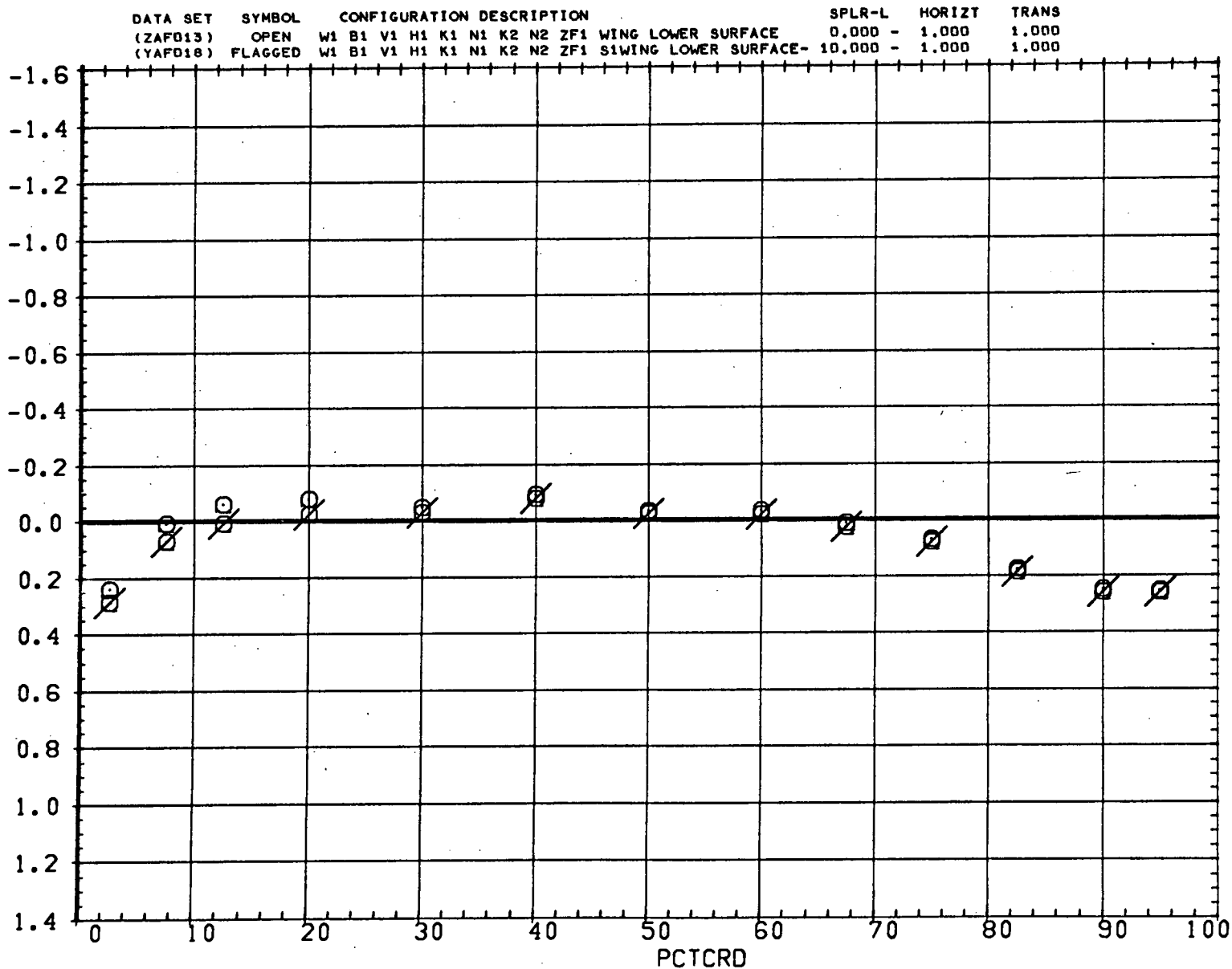

FIG. 22 EFFECT OF SPOILERS ON WING PRESSURE DIST.-WING LOWER SURFACE

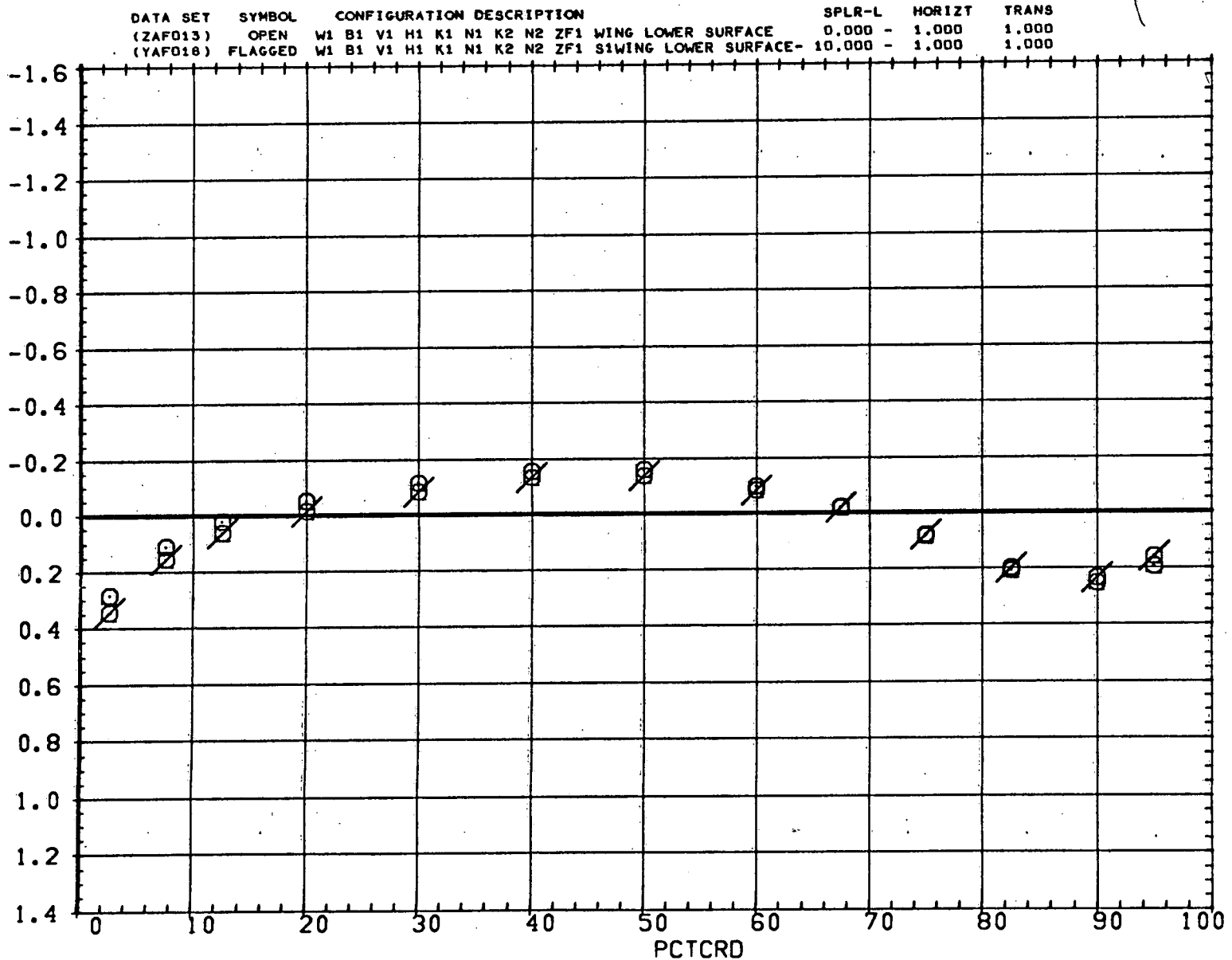

FIG. 22 EFFECT OF SPOILERS ON WING PRESSURE DIST.-WING LOWER SURFACE

SYMBOL ALPHA BL MACH
 ○ 3.460 18.278 0.902

PARAMETRIC VALUES
 BETA 0.000 RN/L 4.000

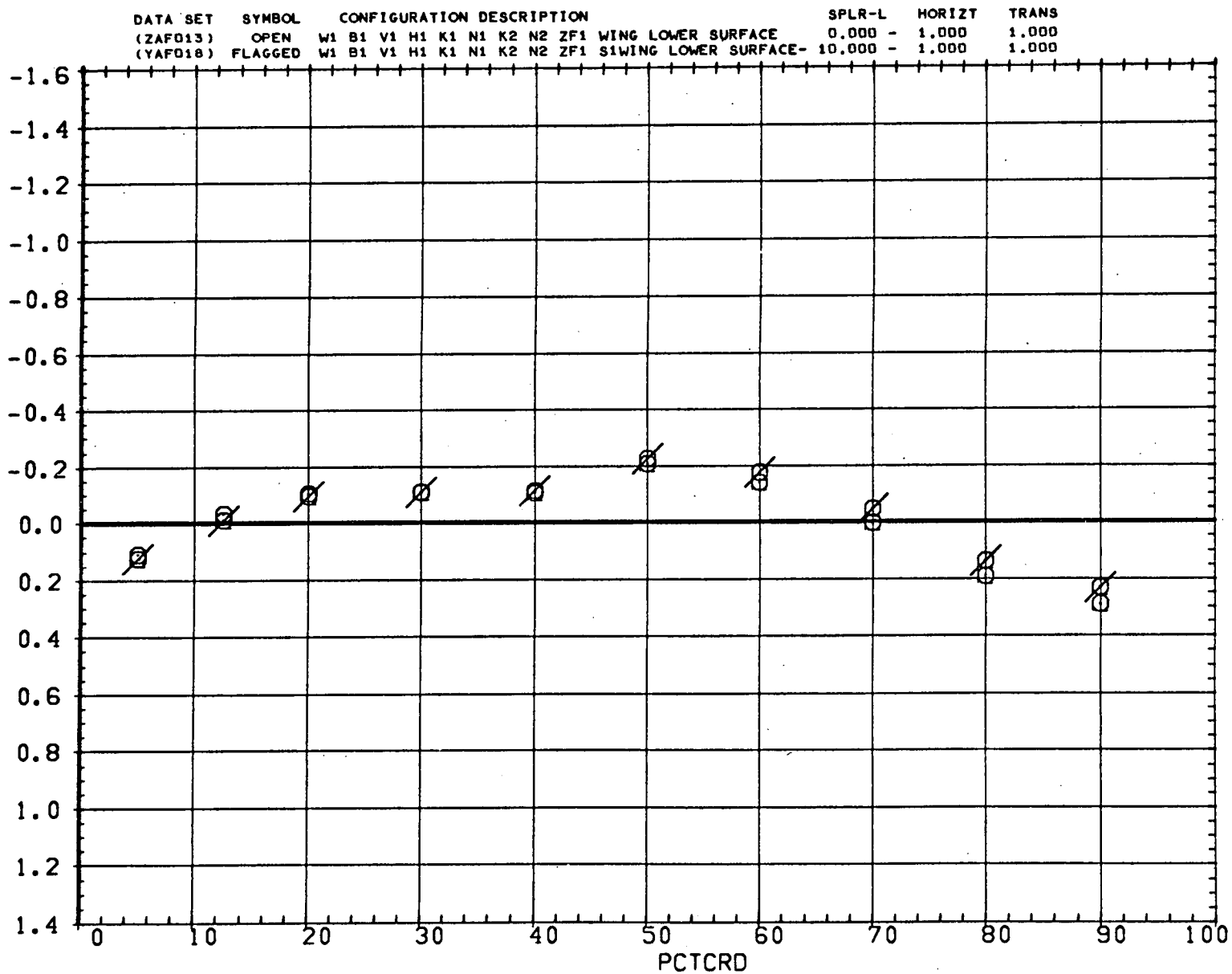

FIG. 22 EFFECT OF SPOILERS ON WING PRESSURE DIST.-WING LOWER SURFACE

DATA SET	SYMBOL	CONFIGURATION DESCRIPTION	SPLR-L	HORIZT	TRANS
(YAFD18)	OPEN	W1 B1 V1 H1 K1 N1 K2 N2 ZF1 S1 WING LOWER SURFACE-	10.000	1.000	1.000
(YAFD19)	FLAGGED	W1 B1 V1 H1 K1 N1 K2 N2 ZF1 S1 WING LOWER SURFACE-	25.000	1.000	1.000

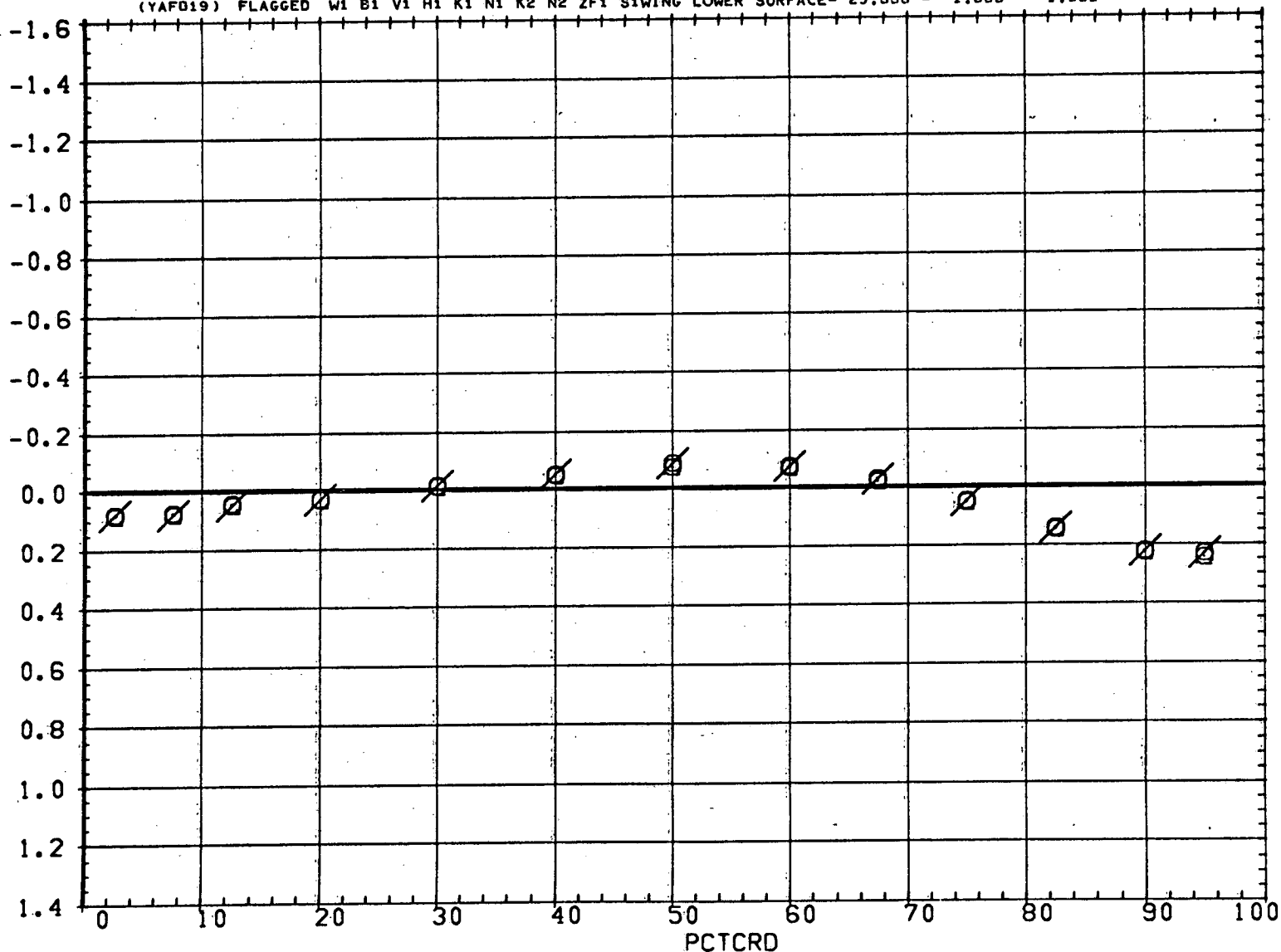

FIG. 22 EFFECT OF SPOILERS ON WING PRESSURE DIST.-WING LOWER SURFACE

SYMBOL ALPHA BL MACH
 ○ 4.000 7.768 0.800

PARAMETRIC VALUES
 BETA 0.000 RN/L 4.000

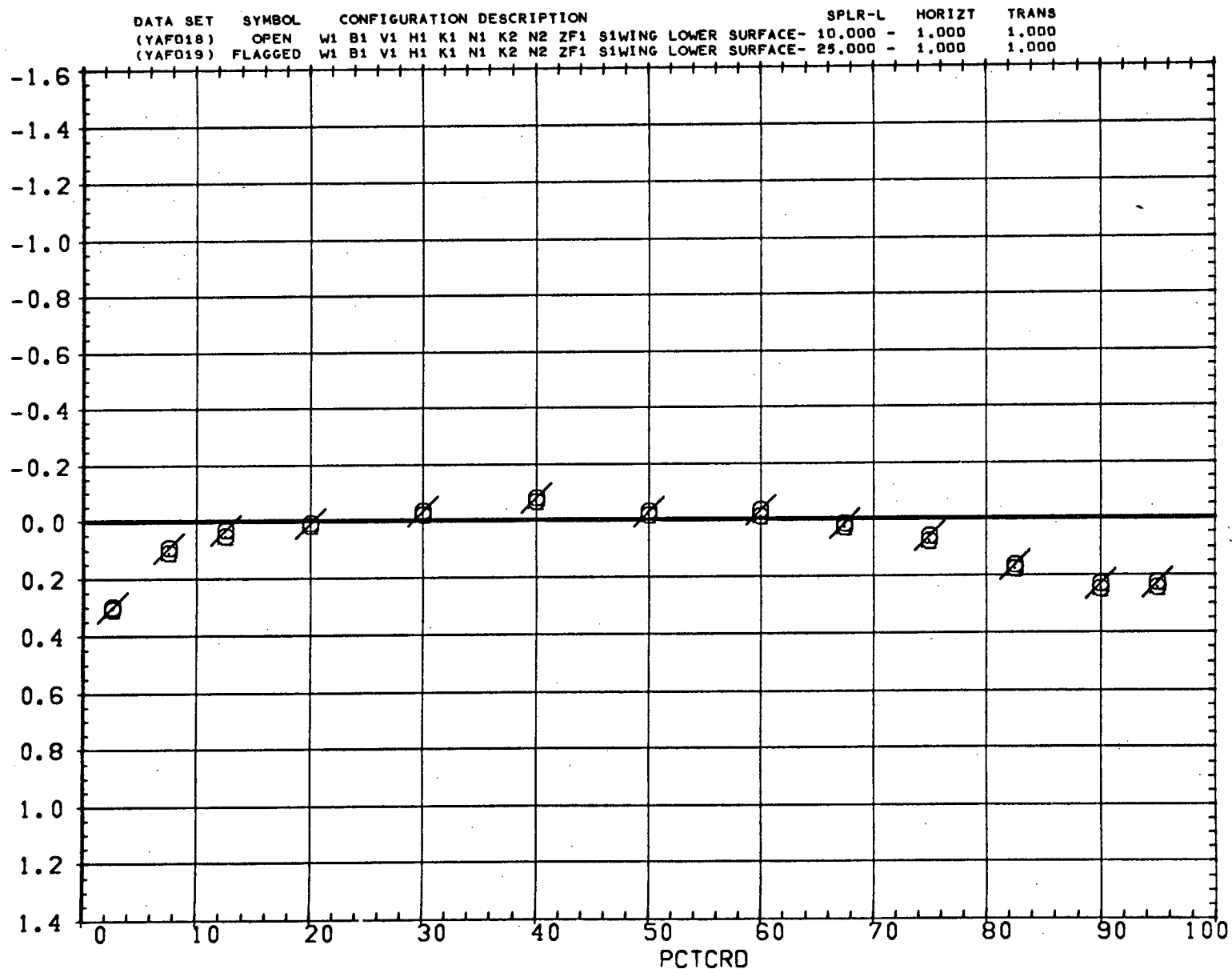

FIG. 22 EFFECT OF SPOILERS ON WING PRESSURE DIST.-WING LOWER SURFACE

DATA SET	SYMBOL	CONFIGURATION DESCRIPTION	SPLR-L	HORIZT	TRANS
(YAFO18)	OPEN	W1 B1 V1 H1 K1 N1 K2 N2 ZF1 S1 WING LOWER SURFACE-	10.000	- 1.000	1.000
(YAFO19)	FLAGGED	W1 B1 V1 H1 K1 N1 K2 N2 ZF1 S1 WING LOWER SURFACE-	25.000	- 1.000	1.000

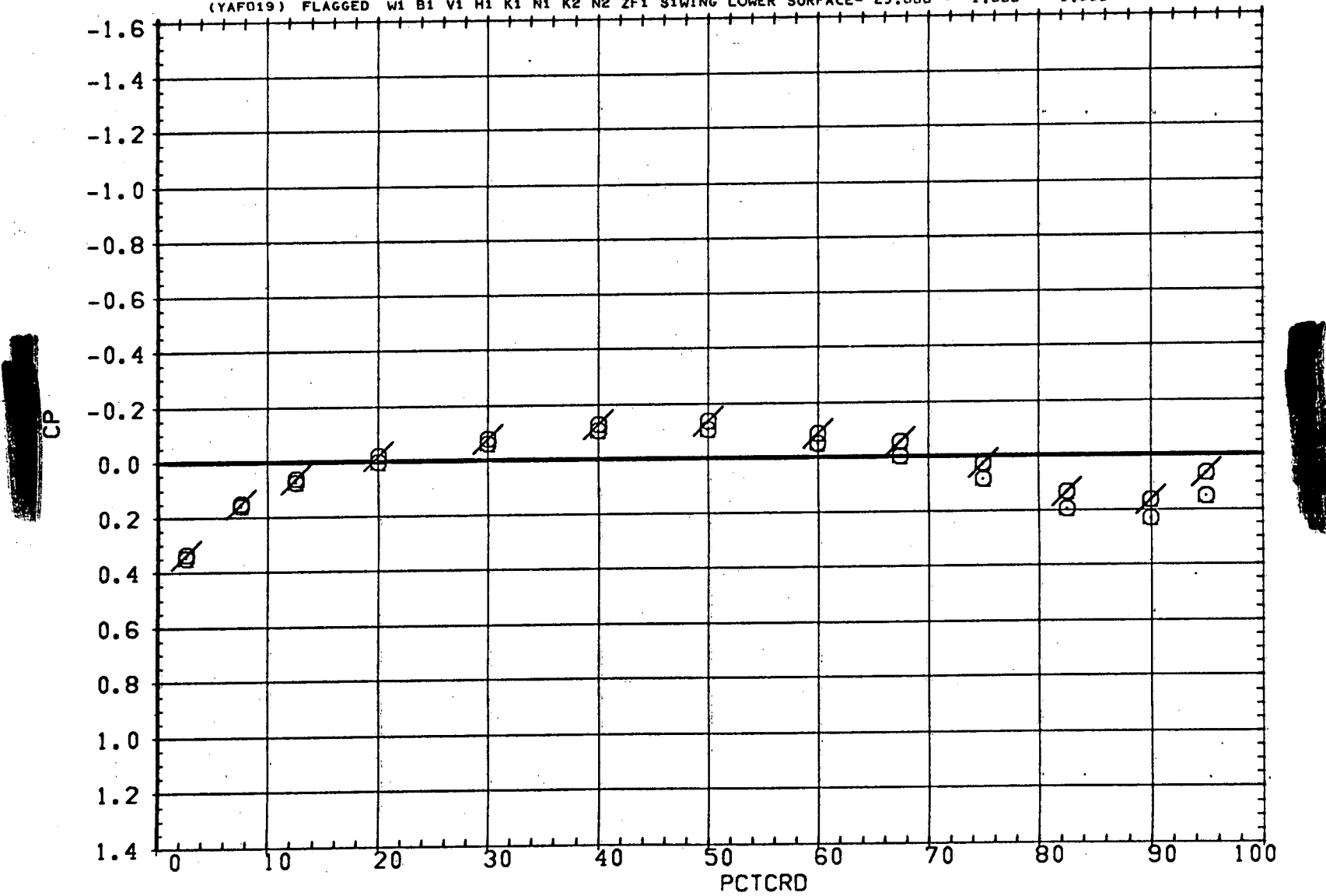

FIG. 22 EFFECT OF SPOILERS ON WING PRESSURE DIST.-WING LOWER SURFACE

SYMBOL ALPHA BL MACH
 ○ 4.000 18.278 0.800

PARAMETRIC VALUES
 BETA 0.000 RN/L 4.000

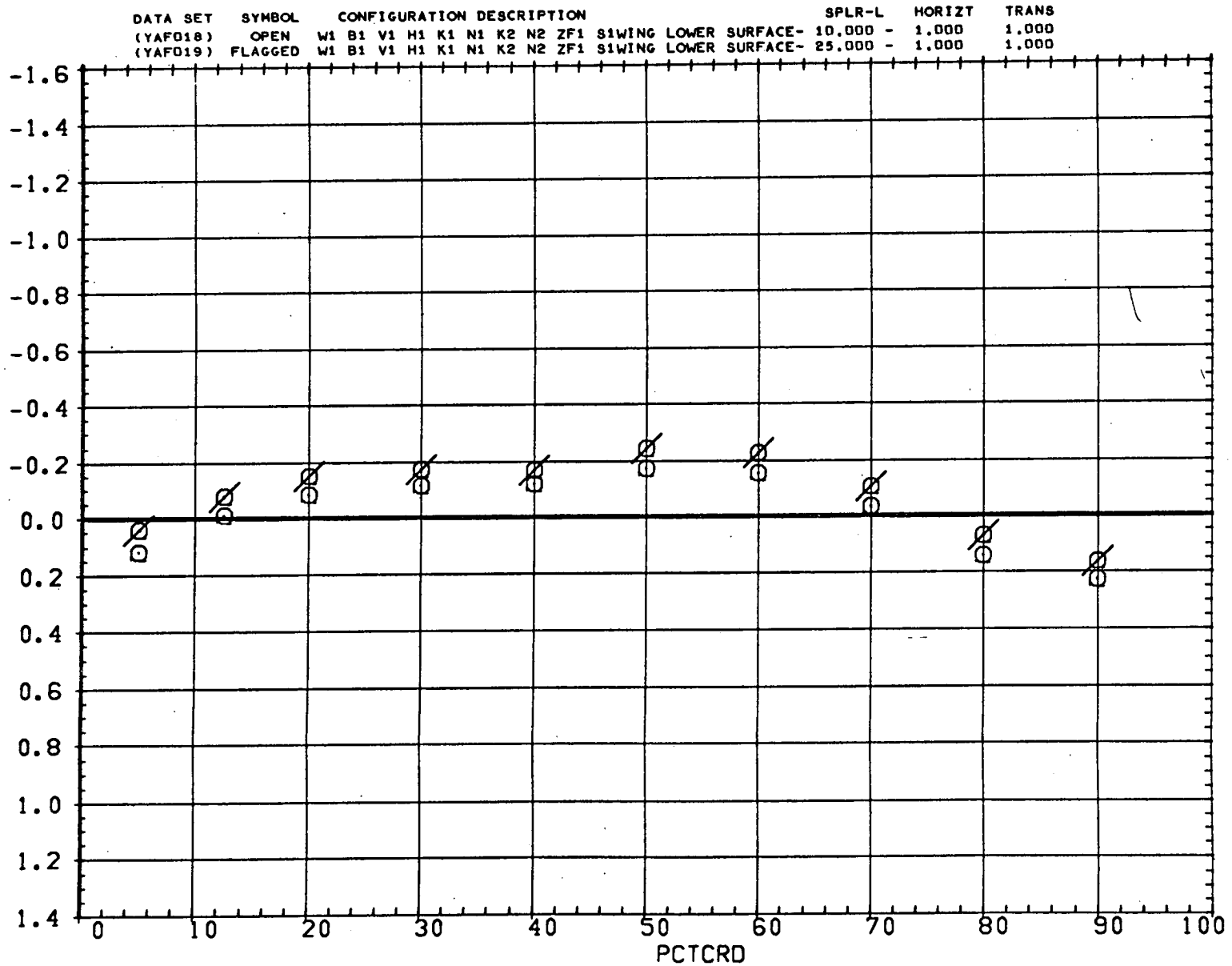

FIG. 22 EFFECT OF SPOILERS ON WING PRESSURE DIST.-WING LOWER SURFACE

DATA SET	SYMBOL	CONFIGURATION	DESCRIPTION	SPLR-L	HORIZT	TRANS
(YAF018)	OPEN	W1 B1 V1 H1 K1 N1 K2 N2 ZF1	S1WING LOWER SURFACE- 10.000' - 1.000'			1.000'
(YAF019)	FLAGGED	W1 B1 V1 H1 K1 N1 K2 N2 ZF1	S1WING LOWER SURFACE- 25.000' - 1.000'			1.000'

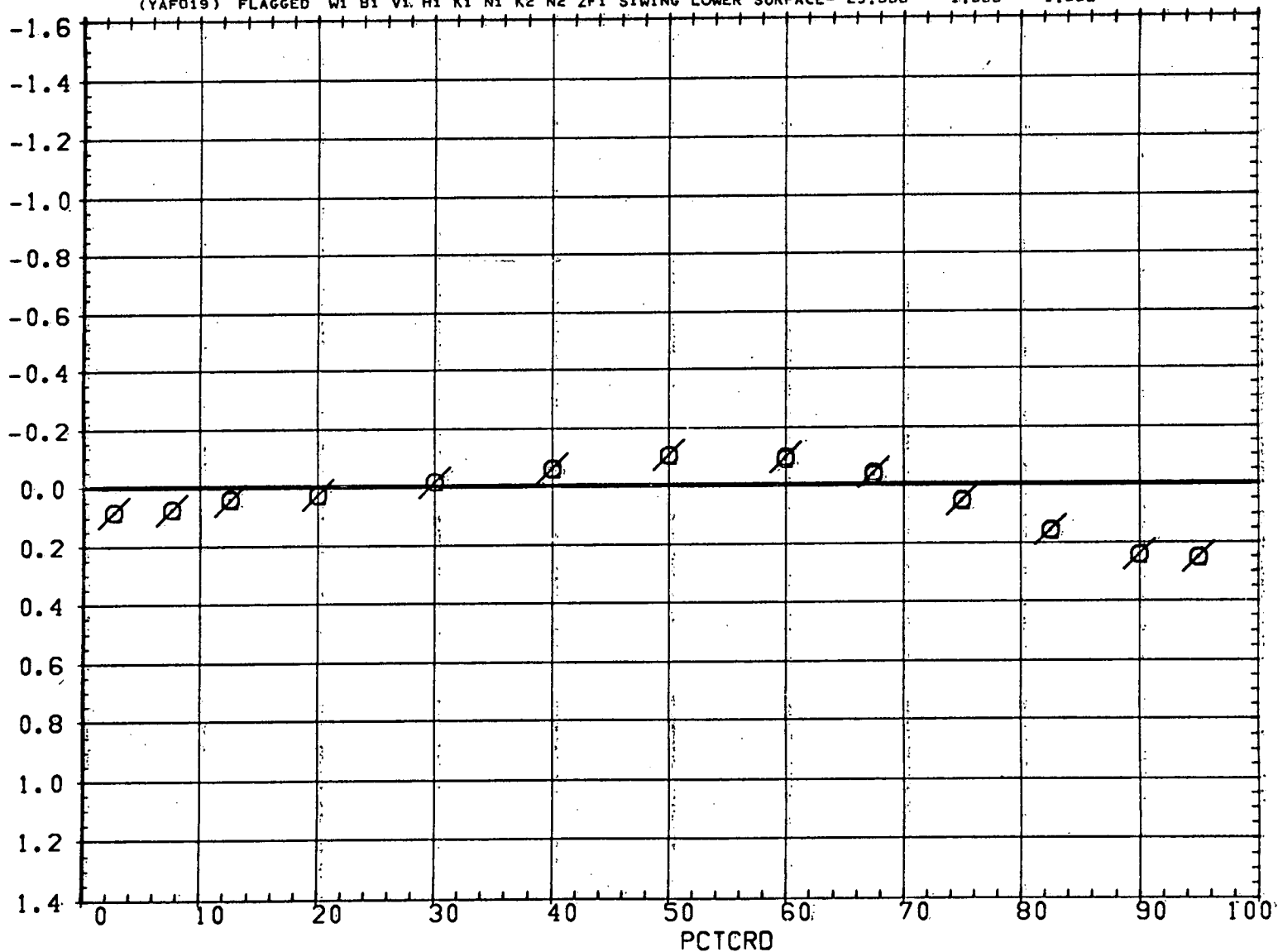

FIG. 22 EFFECT OF SPOILERS ON WING PRESSURE DIST.-WING LOWER SURFACE

SYMBOL ALPHA BL MACH
 O 4.000 7.768 0.902

PARAMETRIC VALUES
 BETA 0.000 RN/L 4.000

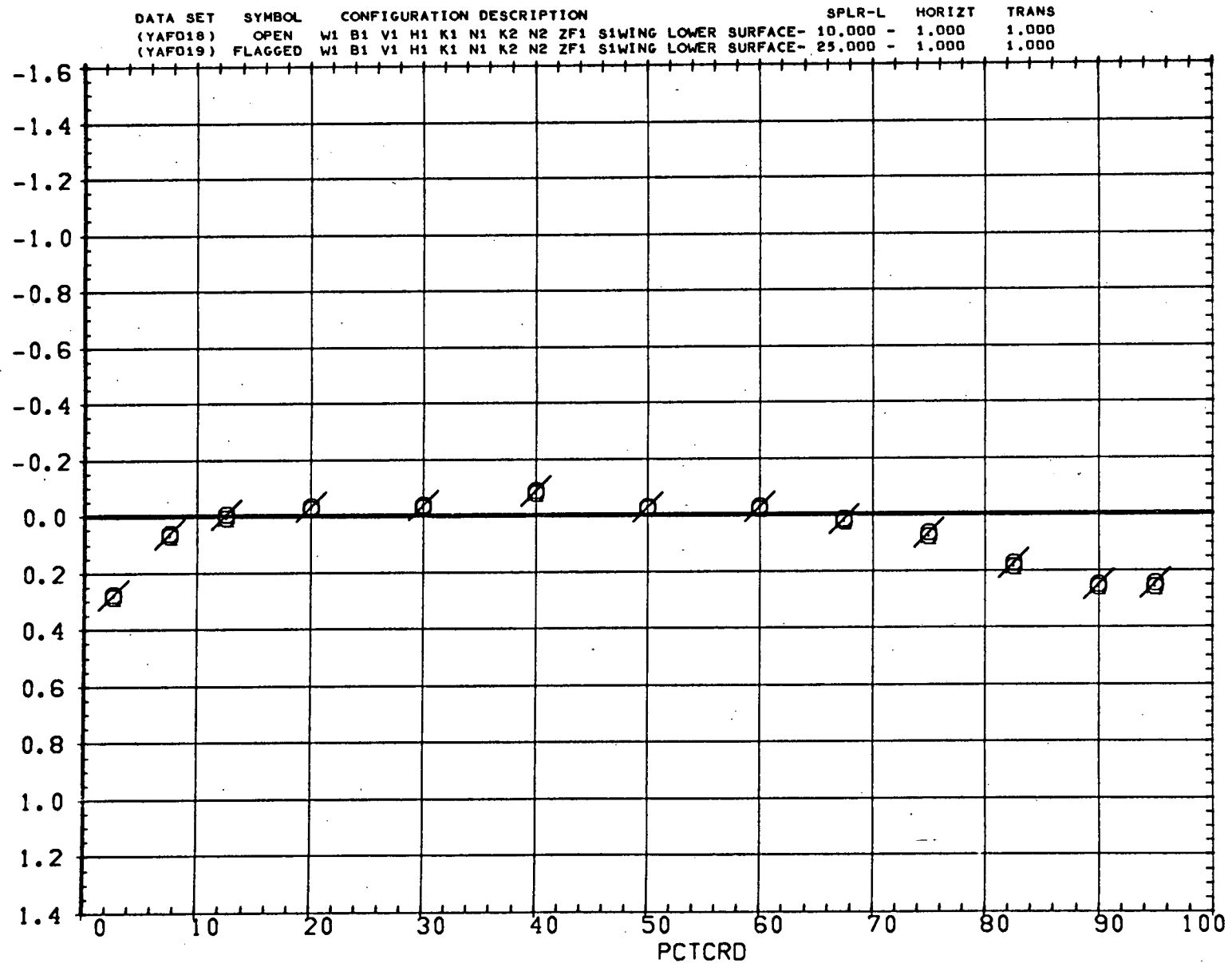

FIG. 22 EFFECT OF SPOILERS ON WING PRESSURE DIST.-WING LOWER SURFACE

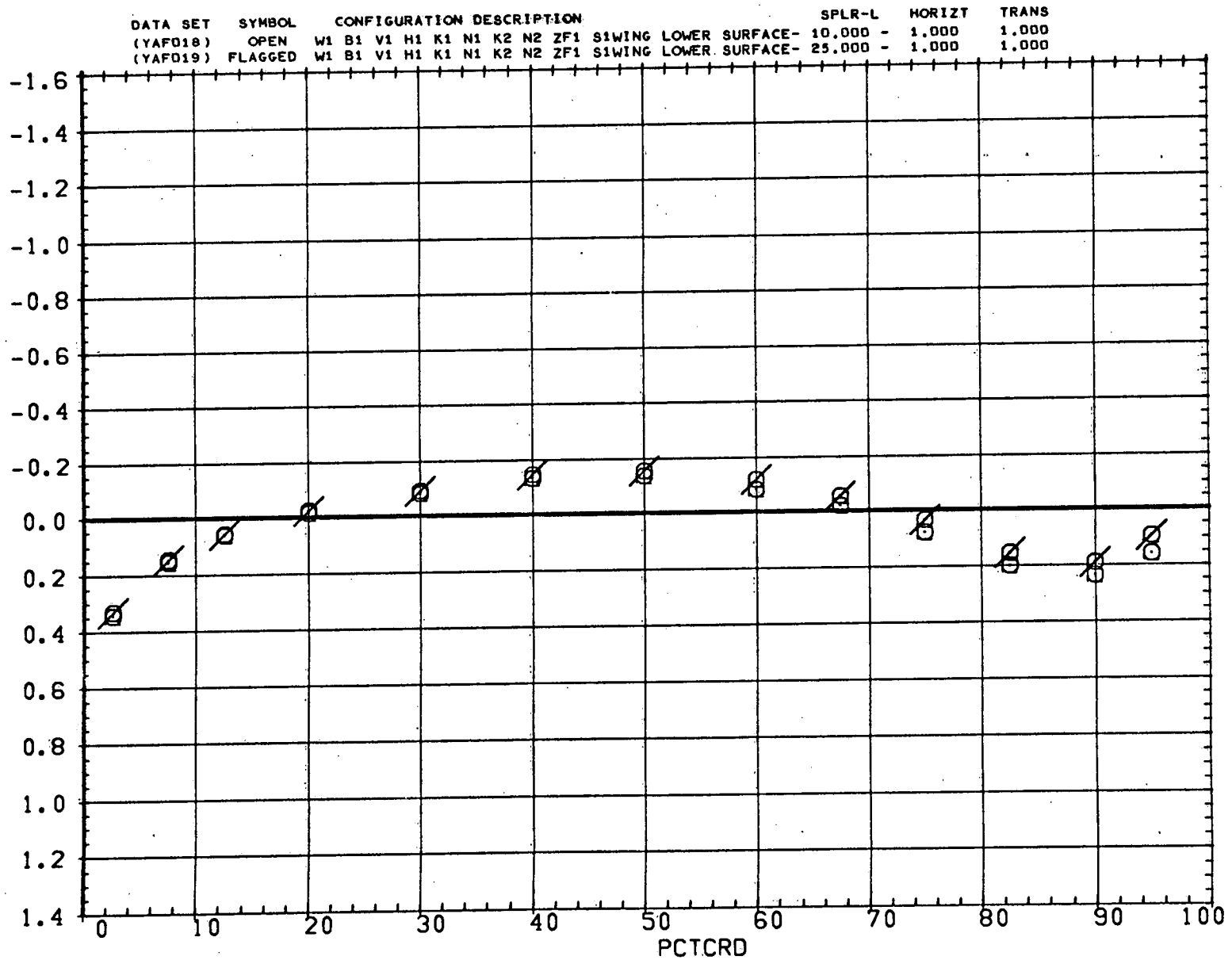

FIG. 22 EFFECT OF SPOILERS ON WING PRESSURE DIST.-WING LOWER SURFACE

SYMBOL ALPHA BL MACH
 ○ 4.000 1E.278 0.902

PARAMETRIC VALUES
 BETA 0.000 RN/L 4.000

DATA SET	SYMBOL	CONFIGURATION DESCRIPTION										SPLR-L	HORIZT	TRANS		
(YAFO18)	OPEN	W1	B1	V1	H1	K1	N1	K2	N2	ZF1	S1	WING LOWER SURFACE-	10.000	-	1.000	1.000
(YAFO19)	FLAGGED	W1	B1	V1	H1	K1	N1	K2	N2	ZF1	S1	WING LOWER SURFACE-	25.000	-	1.000	1.000

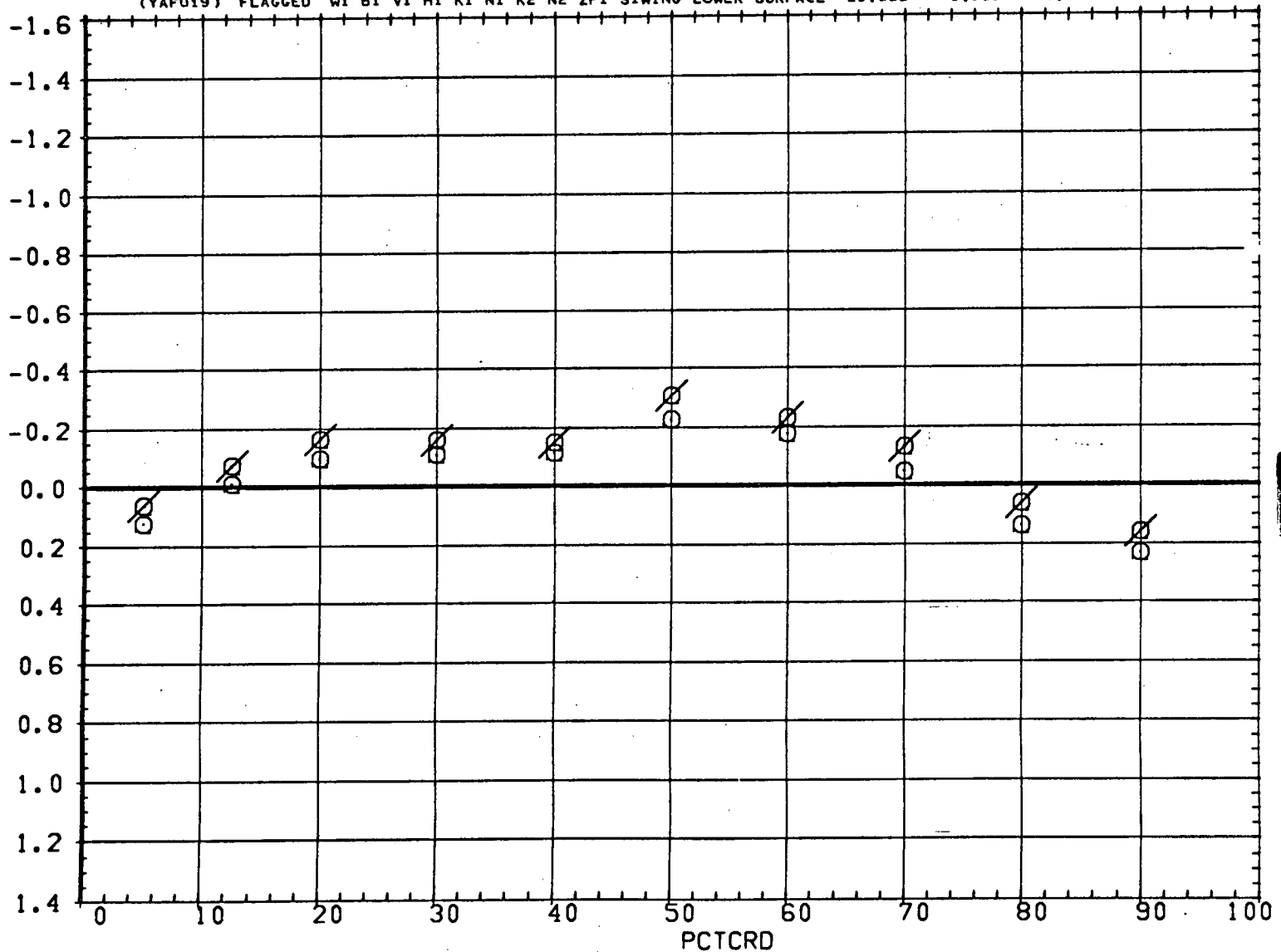

FIG. 22 EFFECT OF SPOILERS ON WING PRESSURE DIST.-WING LOWER SURFACE

DATA SET	SYMBOL	CONFIGURATION DESCRIPTION										SPLR-L	HORIZT	TRANS	
(YAFO18)	OPEN	W1	B1	V1	H1	K1	N1	K2	N2	ZF1	S1	WING LOWER SURFACE-	10.000	- 1.000	1.000
(YAFO19)	FLAGGED	W1	B1	V1	H1	K1	N1	K2	N2	ZF1	S1	WING LOWER SURFACE-	25.000	- 1.000	1.000

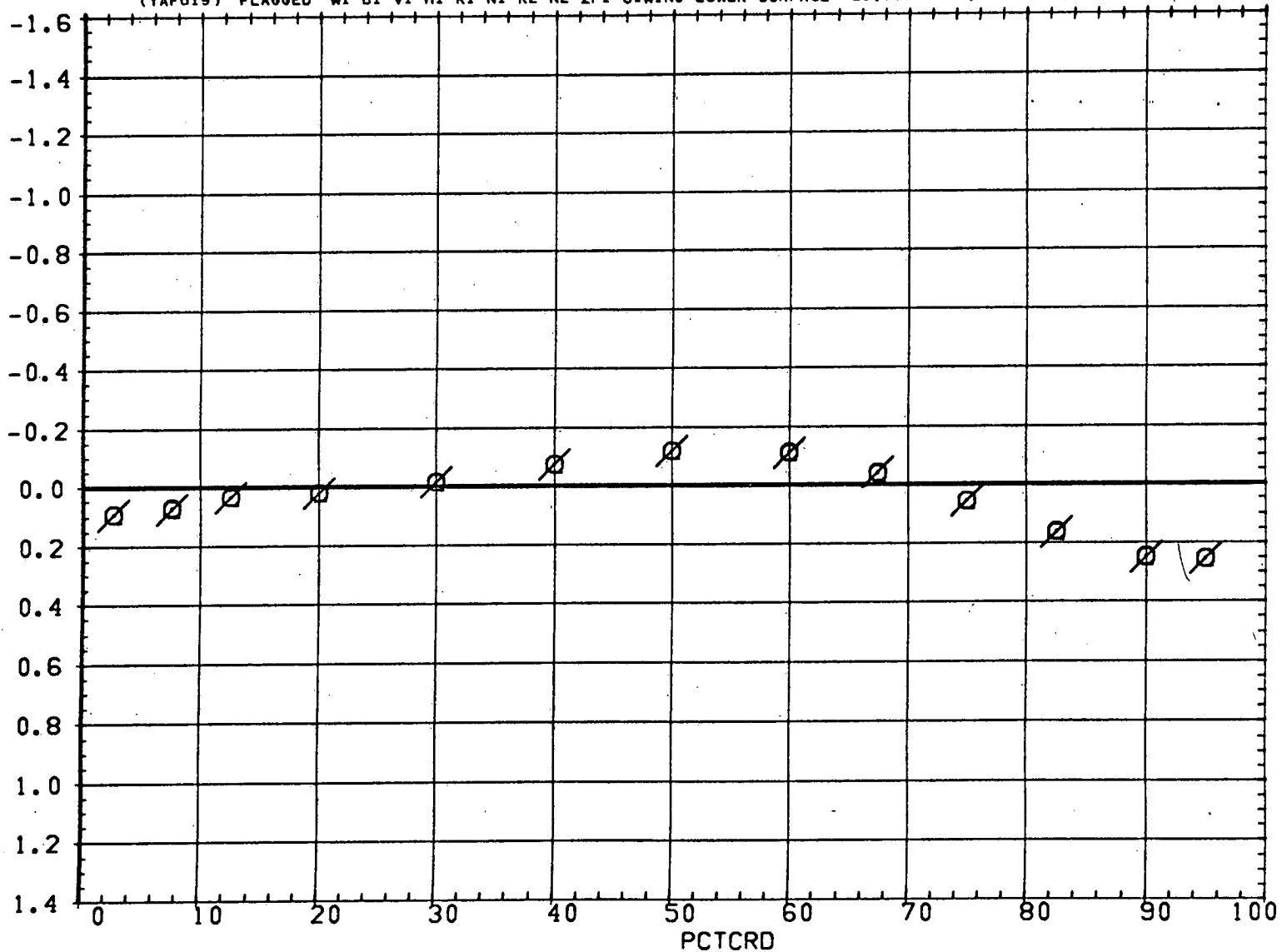

FIG. 22 EFFECT OF SPOILERS ON WING PRESSURE DIST.-WING LOWER SURFACE

SYMBOL ALPHA BL MACH
 O 3.980 7.768 0.949

PARAMETRIC VALUES
 BETA 0.000 RN/L 4.000

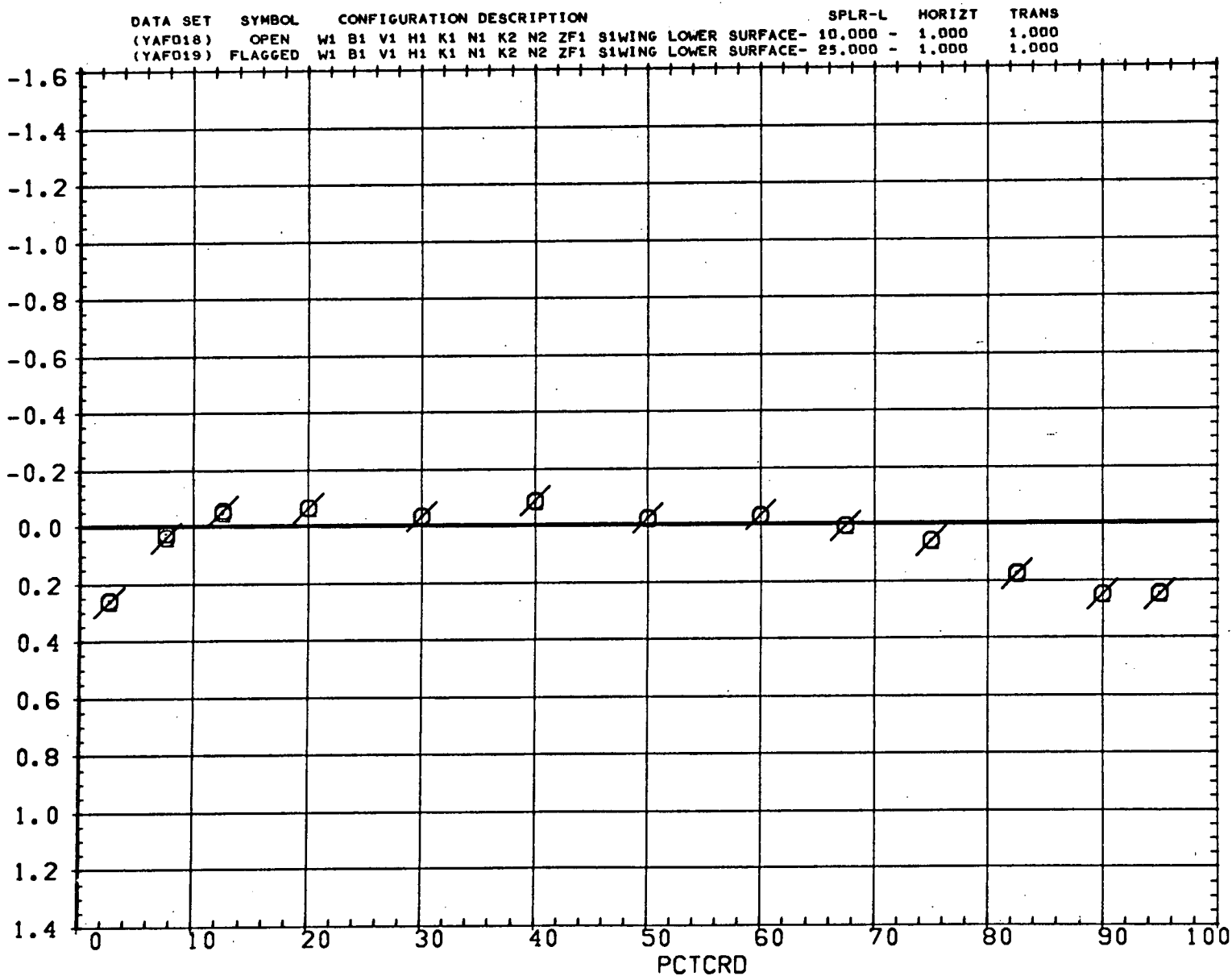

FIG. 22 EFFECT OF SPOILERS ON WING PRESSURE DIST.-WING LOWER SURFACE

DATA SET	SYMBOL	CONFIGURATION	DESCRIPTION	SPLR-L	HORIZT	TRANS
(YAFO18)	OPEN	W1 B1 V1 H1 K1 N1 K2 N2 ZF1	S1WING LOWER SURFACE-	10.000	- 1.000	1.000
(YAFO19)	FLAGGED	W1 B1 V1 H1 K1 N1 K2 N2 ZF1	S1WING LOWER SURFACE-	25.000	- 1.000	1.000

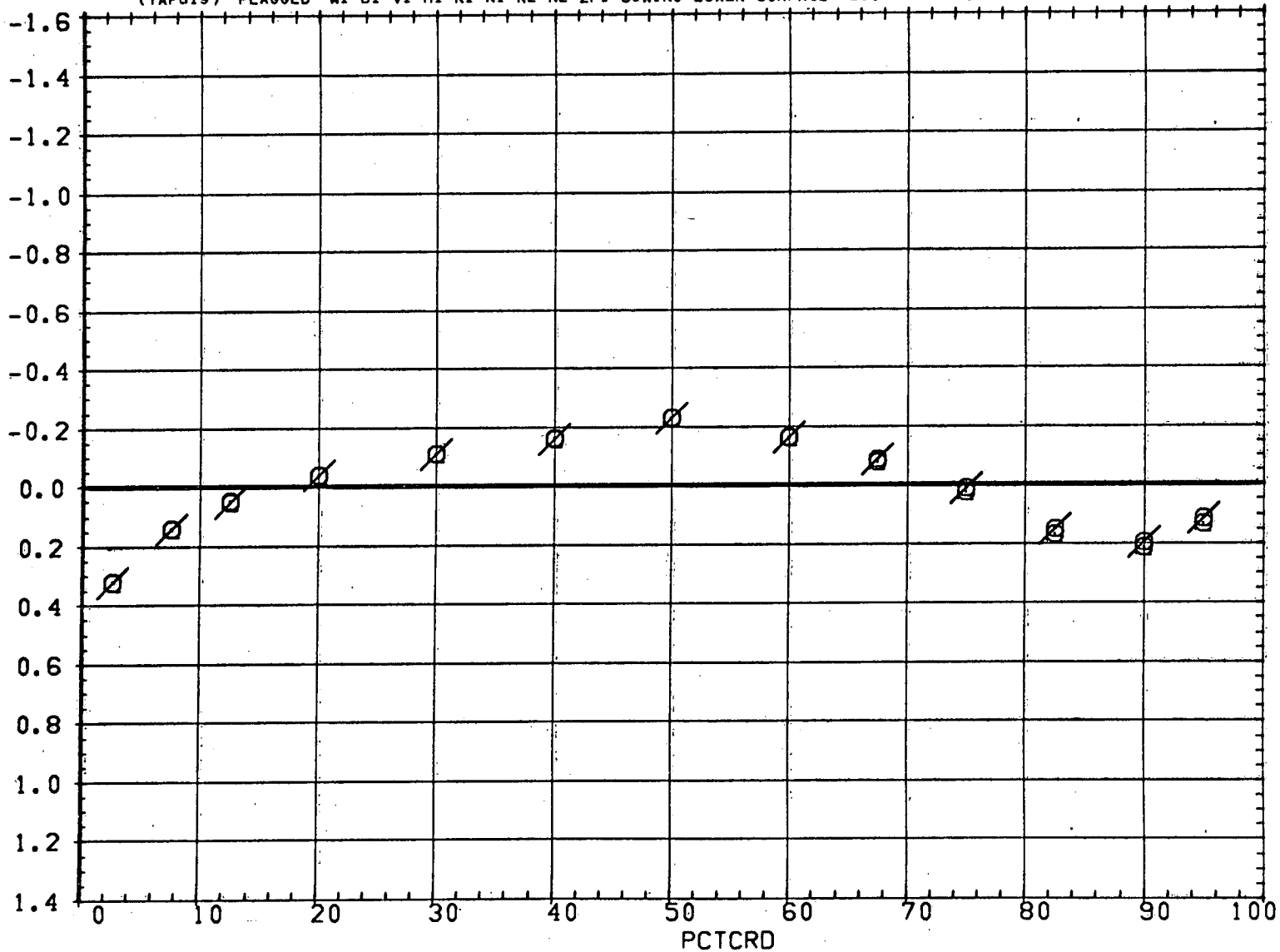

FIG. 22 EFFECT OF SPOILERS ON WING PRESSURE DIST.-WING LOWER SURFACE

SYMBOL ALPHA BL MACH
 O 3.980 18.278 0.949

BETA PARAMETRIC VALUES
 0.000 RN/L 4.000

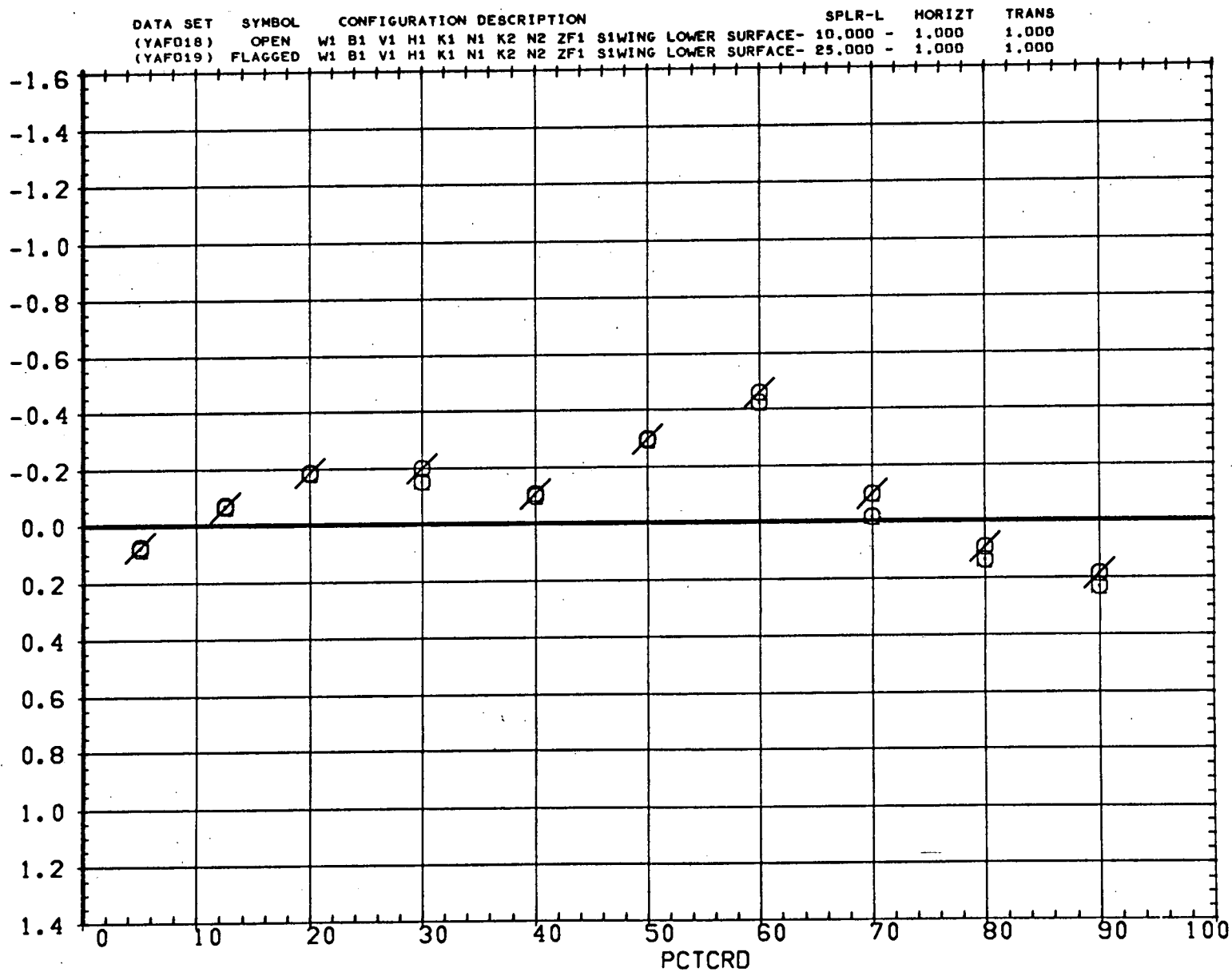

FIG. 22 EFFECT OF SPOILERS ON WING PRESSURE DIST.-WING LOWER SURFACE

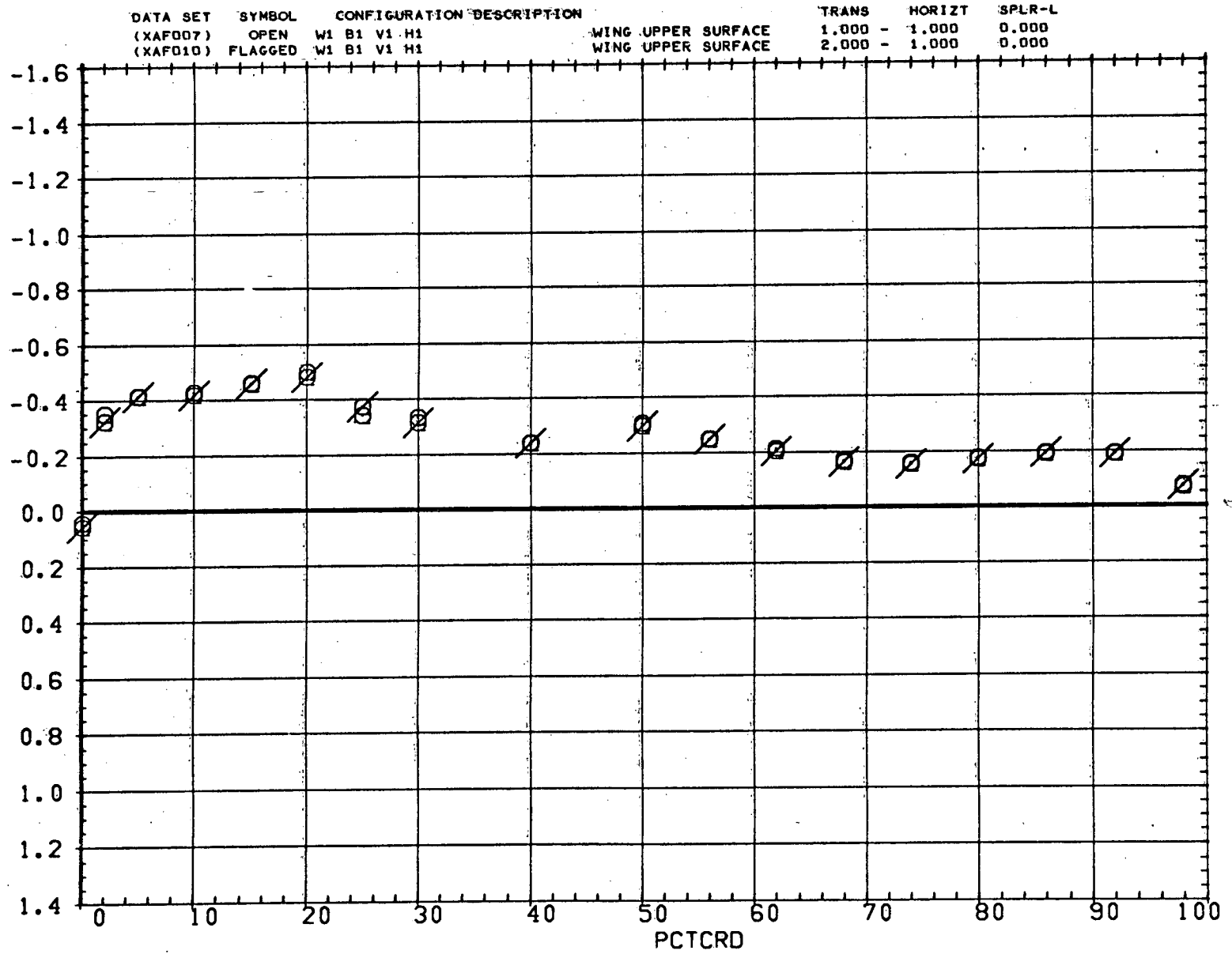

FIG. 23 EFFECT OF TRANS. STRIP LOCATION ON WING PRESSURE DIST.-WING UPPER SURF.

SYMBOL ALPHA BL MACH
 O 3.630 7.768 0.899

PARAMETRIC VALUES
 BETA 0.000 RN/L 4.000

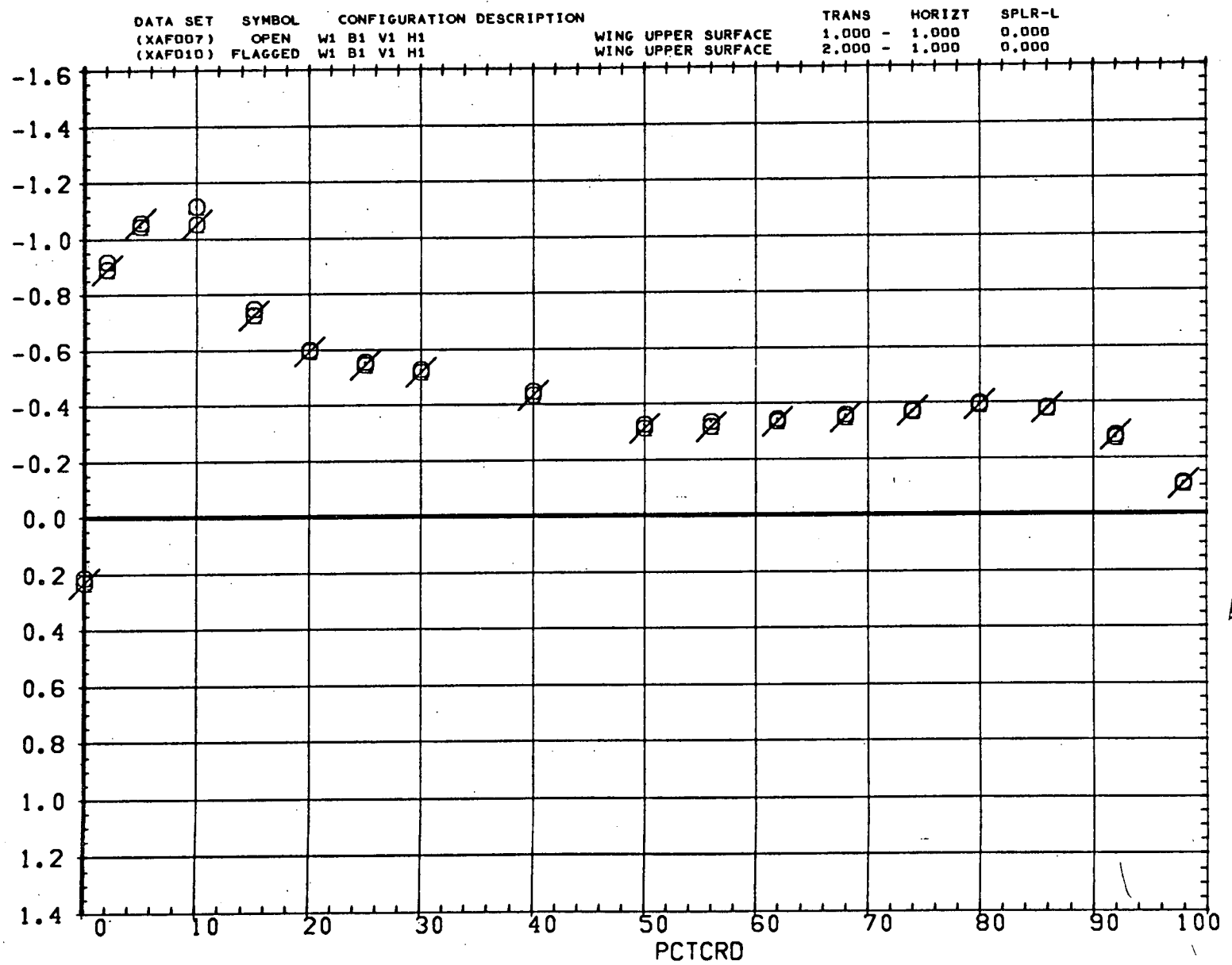

FIG. 23 EFFECT OF TRANS. STRIP LOCATION ON WING PRESSURE DIST.-WING UPPER SURF.

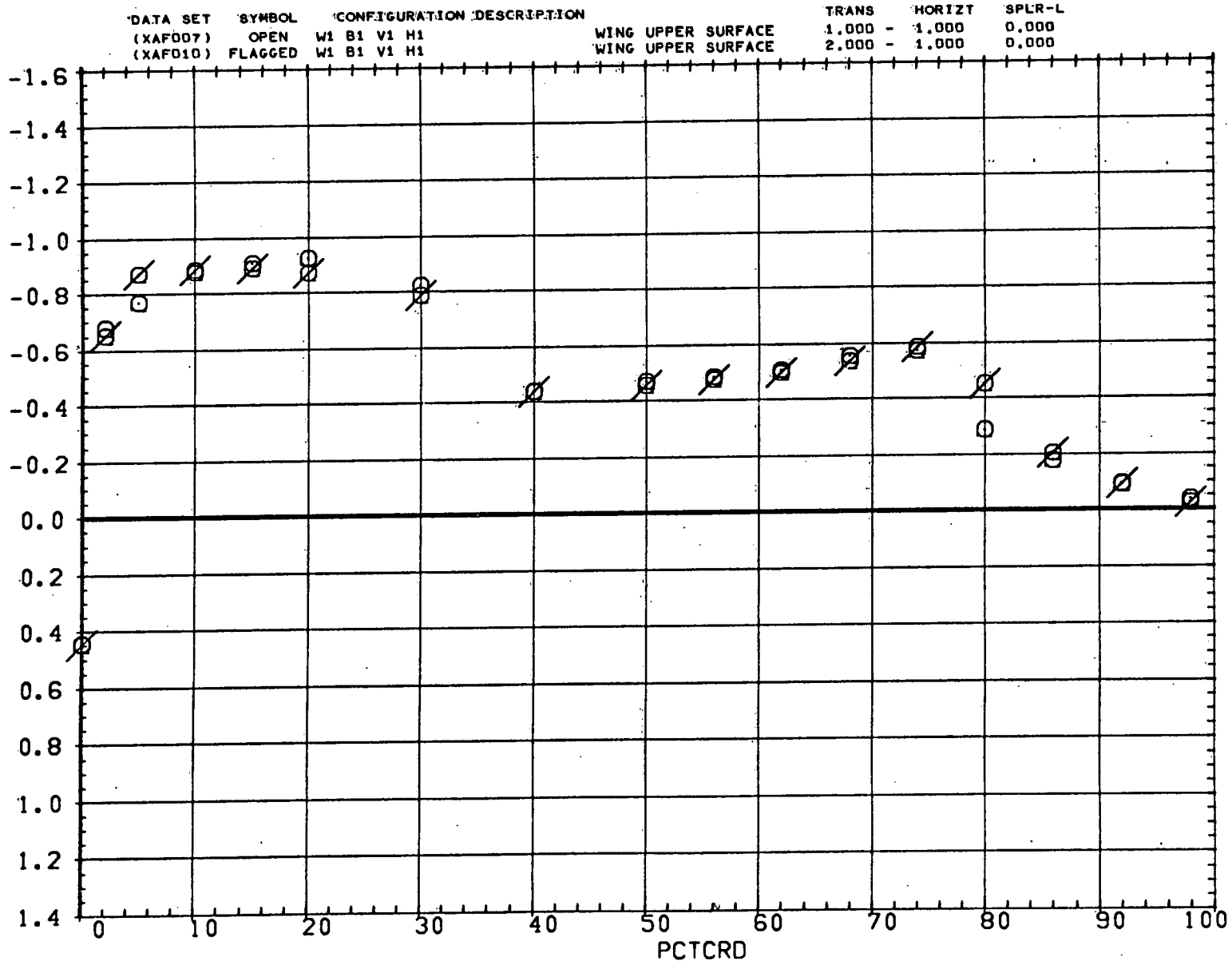

FIG. 23 EFFECT OF TRANS. STRIP LOCATION ON WING PRESSURE DIST.-WING UPPER SURF.

SYMBOL ALPHA BL MACH
 ○ 3.630 18.278 0.899

PARAMETRIC VALUES
 BETA 0.000 RN/L 4.000

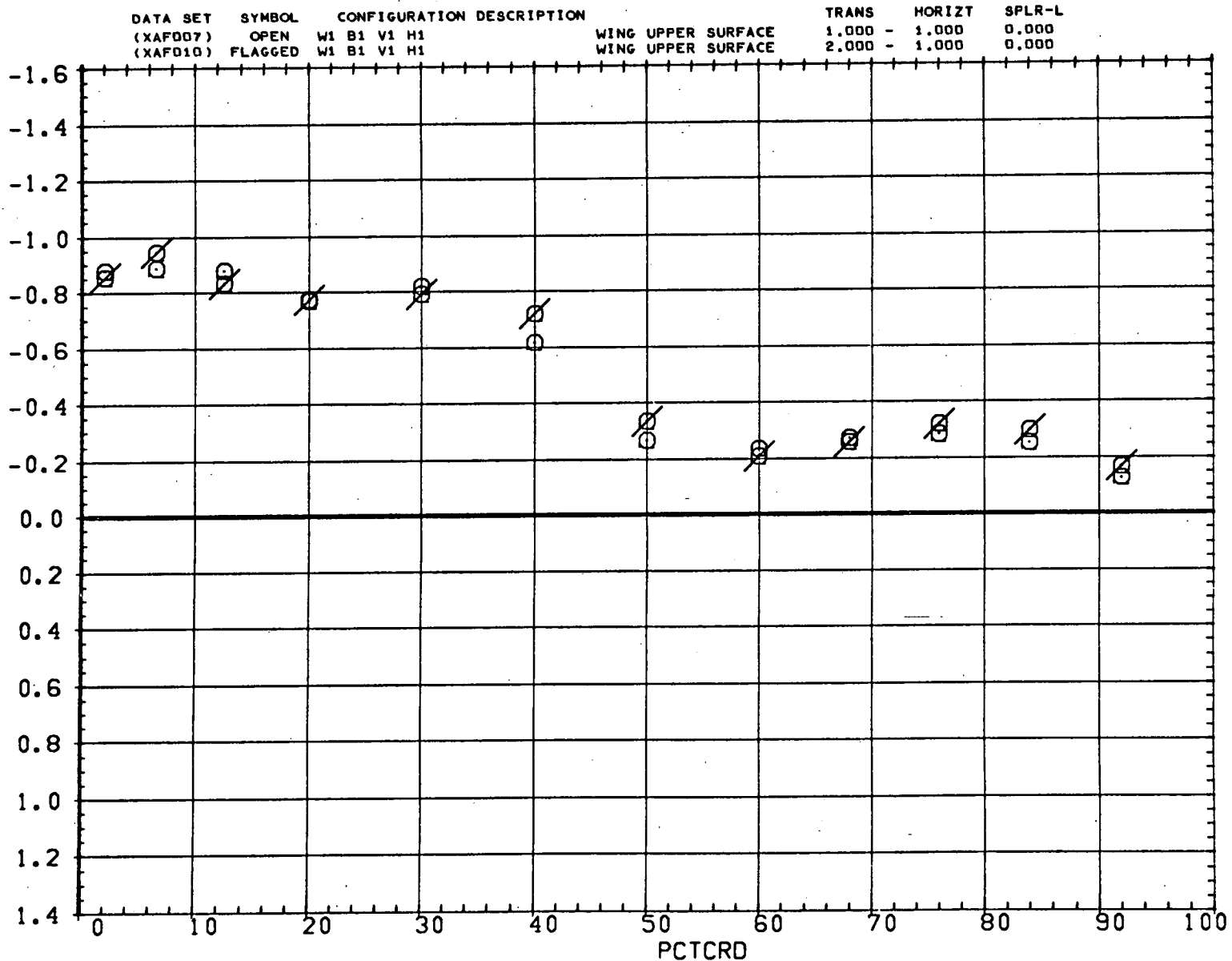

FIG. 23 EFFECT OF TRANS. STRIP LOCATION ON WING PRESSURE DIST.-WING UPPER SURF.

SYMBOL ALPHA BL MACH
 O 3.580 4.250 0.951

BETA PARAMETRIC VALUES
 0.000 RN/L 4.000

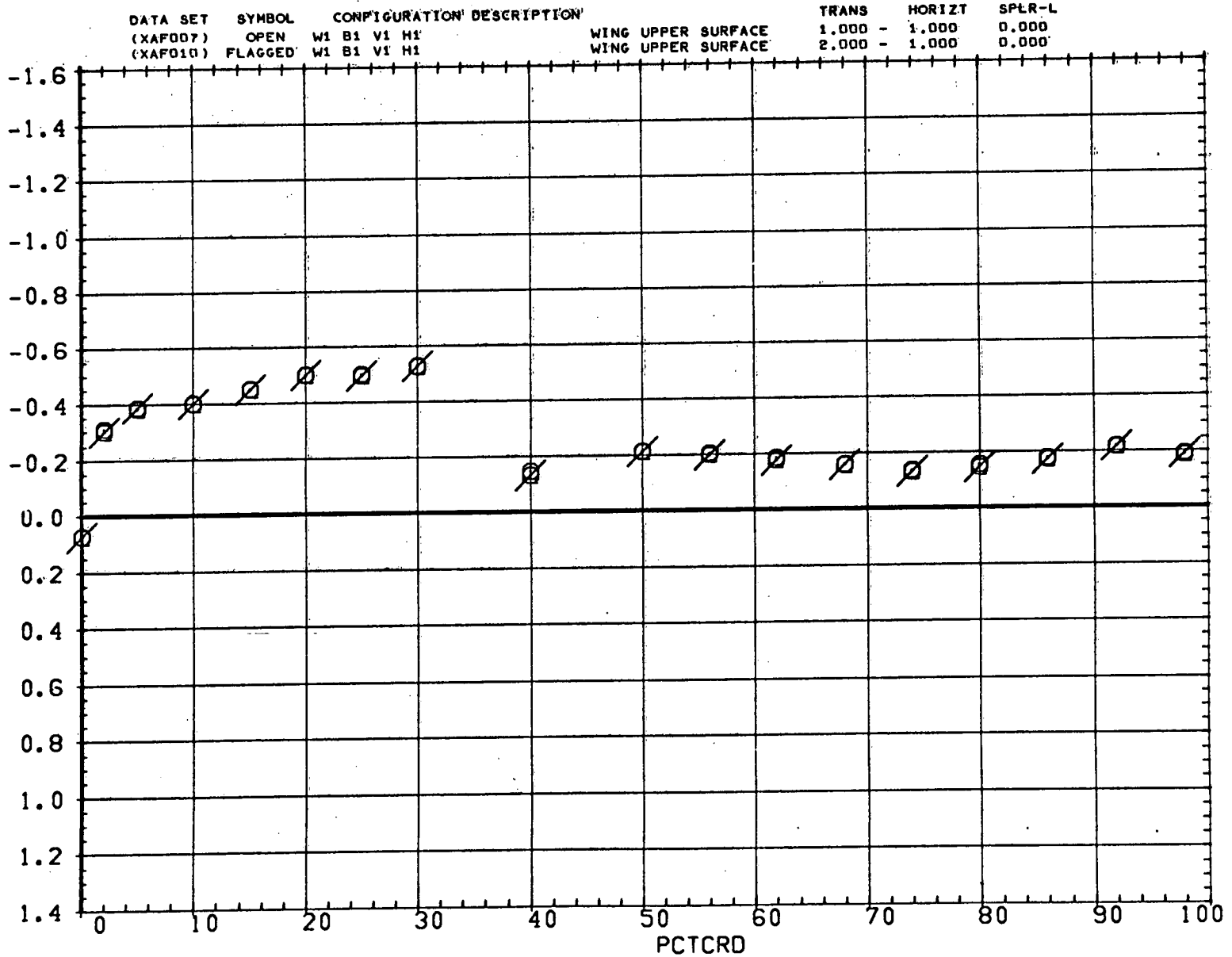

FIG. 23 EFFECT OF TRANS. STRIP LOCATION ON WING PRESSURE DIST.-WING UPPER SURF.

SYMBOL ALPHA BL MACH
 ○ 3.580 7.768 0.951

PARAMETRIC VALUES
 BETA 0.000 RN/L 4.000

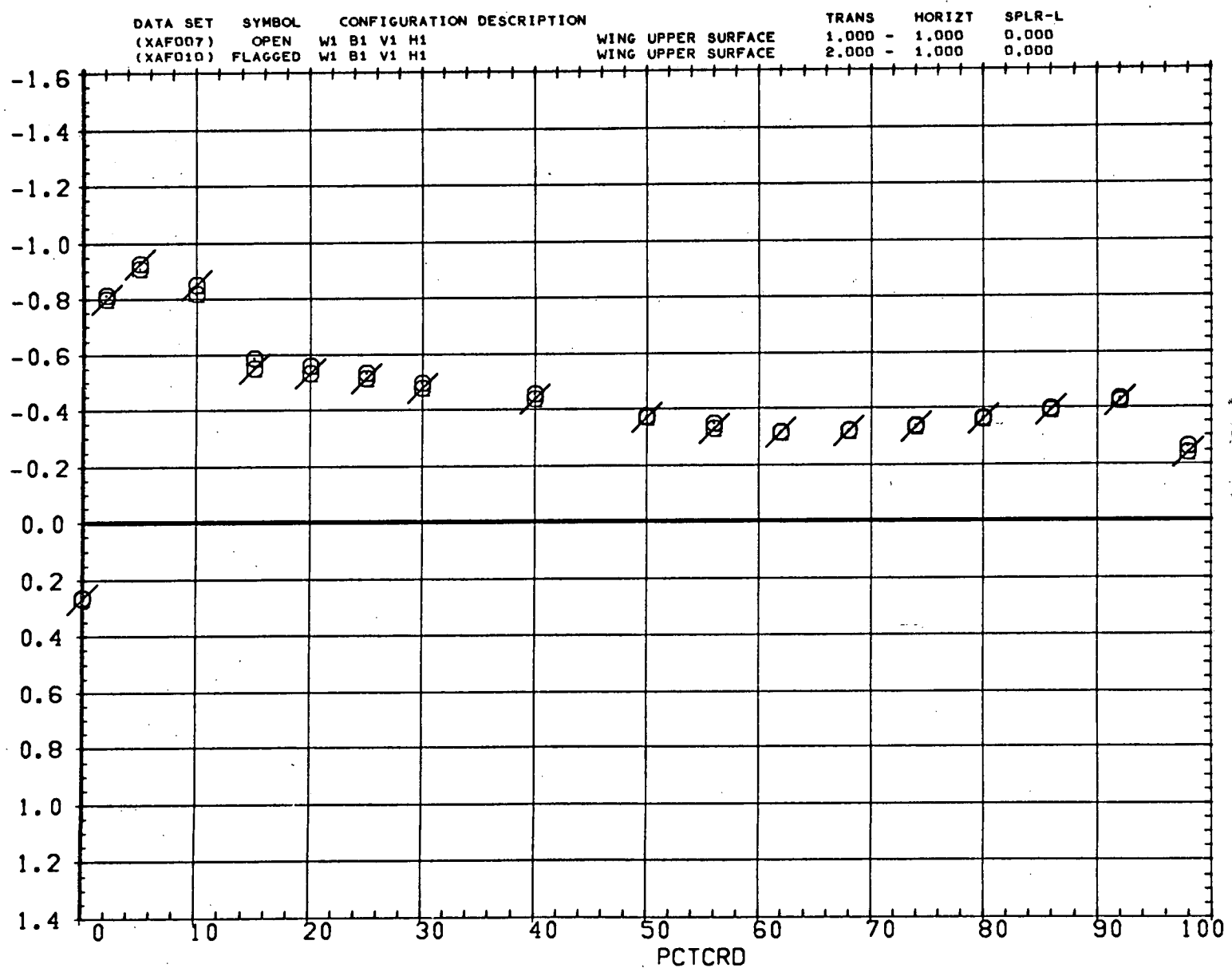

FIG. 23 EFFECT OF TRANS. STRIP LOCATION ON WING PRESSURE DIST.-WING UPPER SURF.

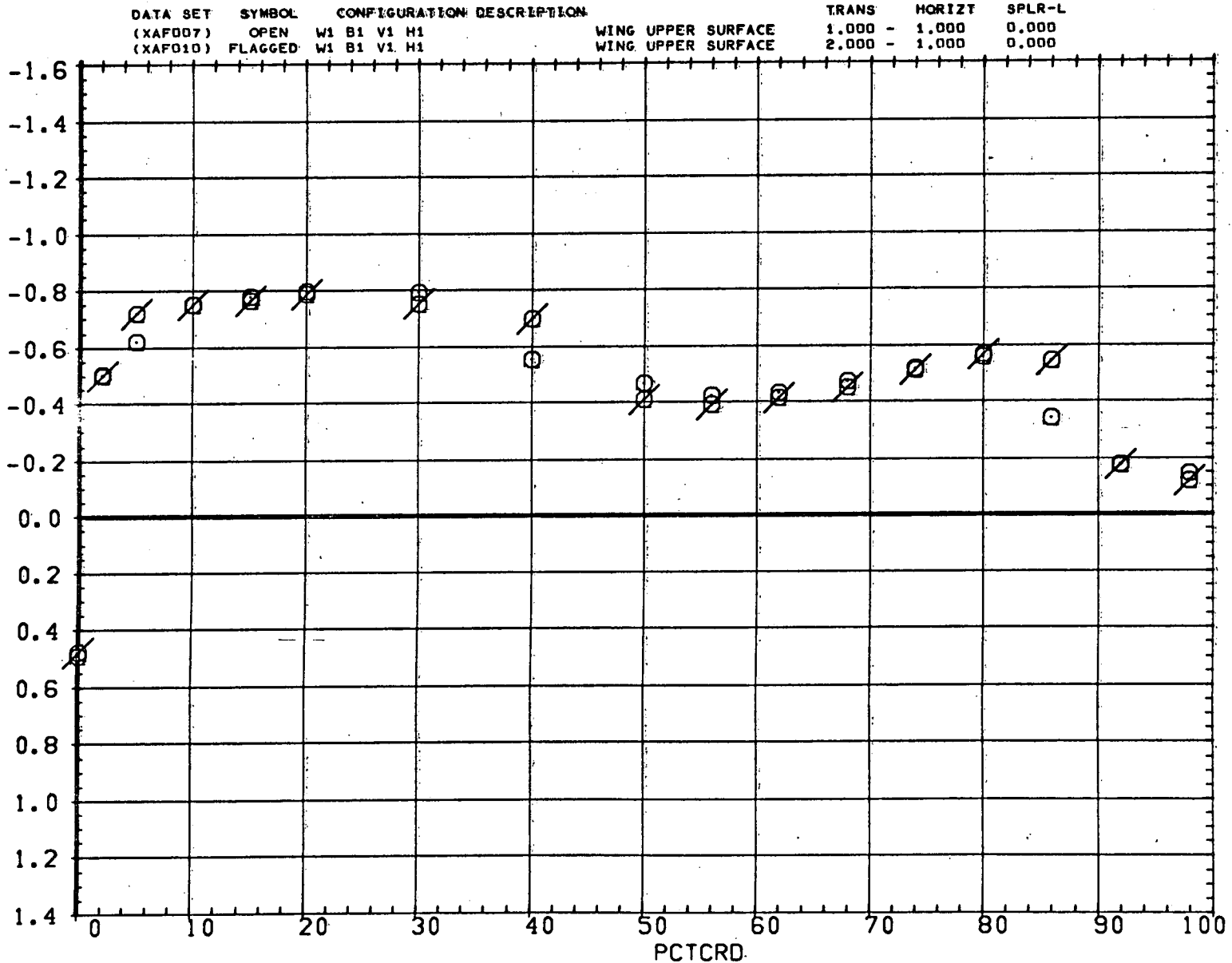

FIG. 23 EFFECT OF TRANS. STRIP LOCATION ON WING PRESSURE DIST.-WING UPPER SURF.

SYMBOL ALPHA BL MACH
 ○ 3.580 18.278 0.951

PARAMETRIC VALUES
 BETA 0.000 RN/L 4.000

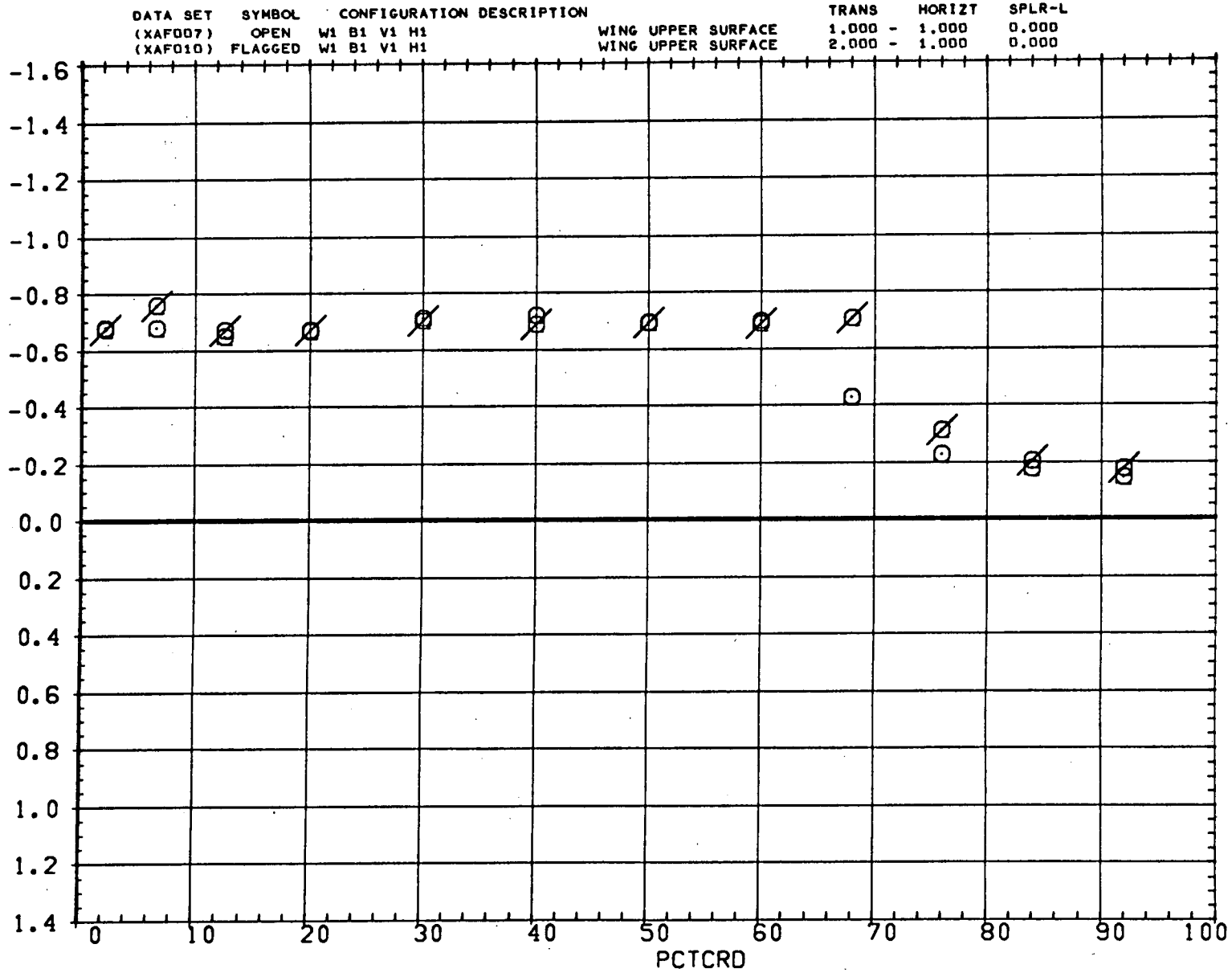

FIG. 23 EFFECT OF TRANS. STRIP LOCATION ON WING PRESSURE DIST.-WING UPPER SURF.

SYMBOL ALPHA BL MACH
 O 3.630 4.250 0.899

PARAMETRIC VALUES
 BETA 0.000 RN/L 4.000

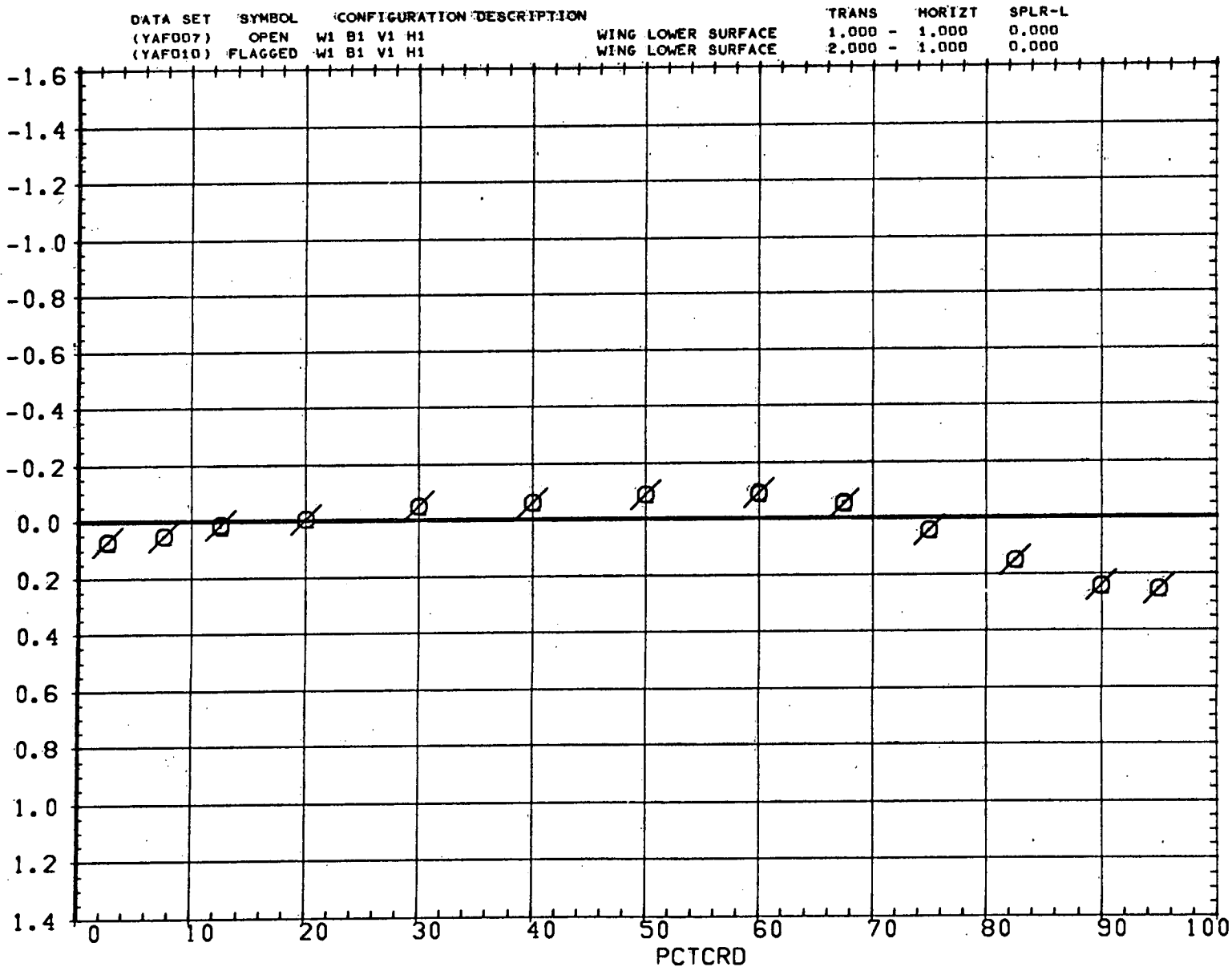

FIG. 24 EFFECT OF TRANS. STRIP LOCATION ON WING PRESSURE DIST.-WING LOWER SURF.

SYMBOL ALPHA BL MACH
 ○ 3.630 7.768 0.899

PARAMETRIC VALUES
 BETA 0.000 RN/L 4.000

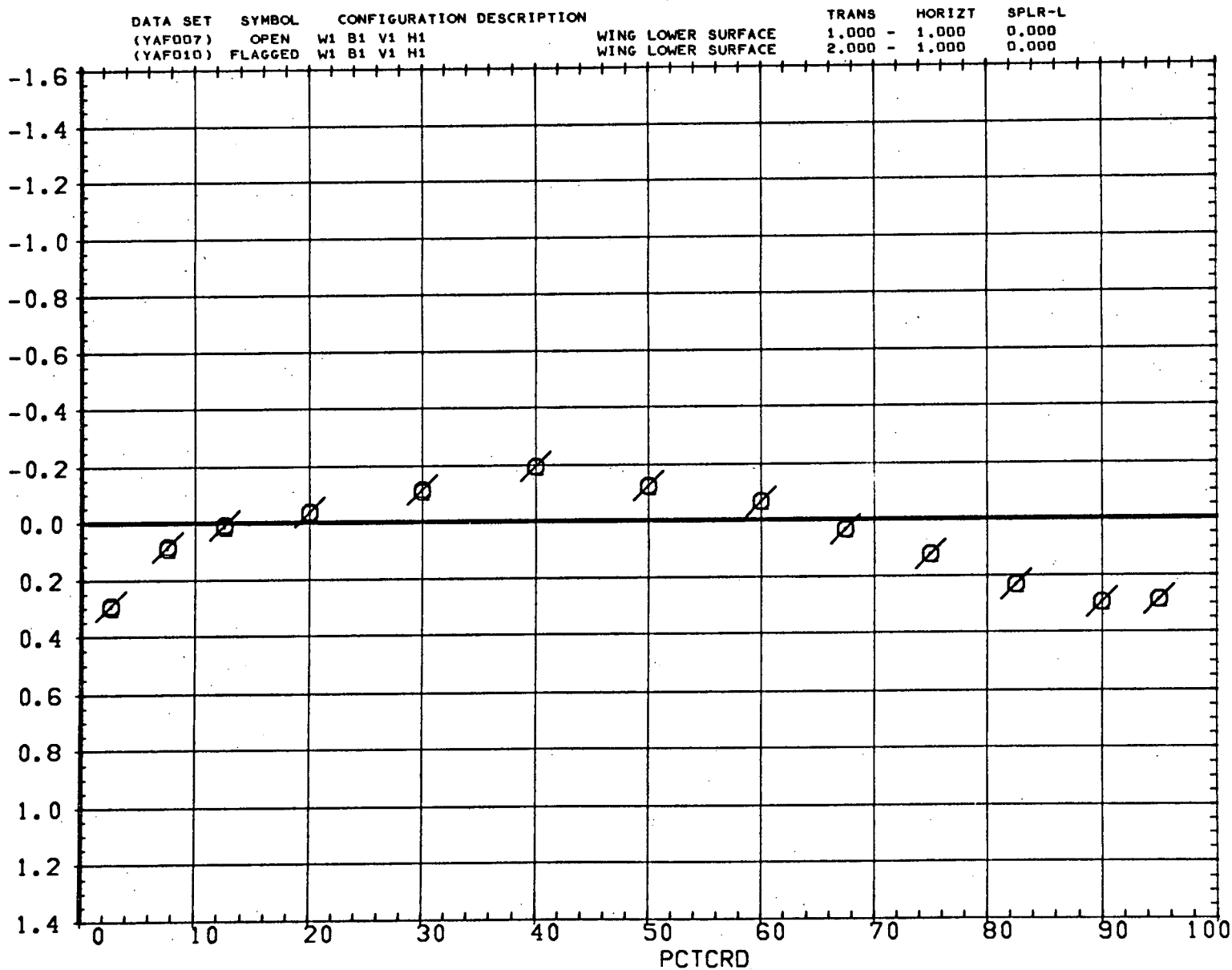

FIG. 24 EFFECT OF TRANS. STRIP LOCATION ON WING PRESSURE DIST.-WING LOWER SURF.

SYMBOL ALPHA BL MACH
 O 3.630 11.424 0.899

PARAMETRIC VALUES
 BETA 0.000 RN/L 4.000

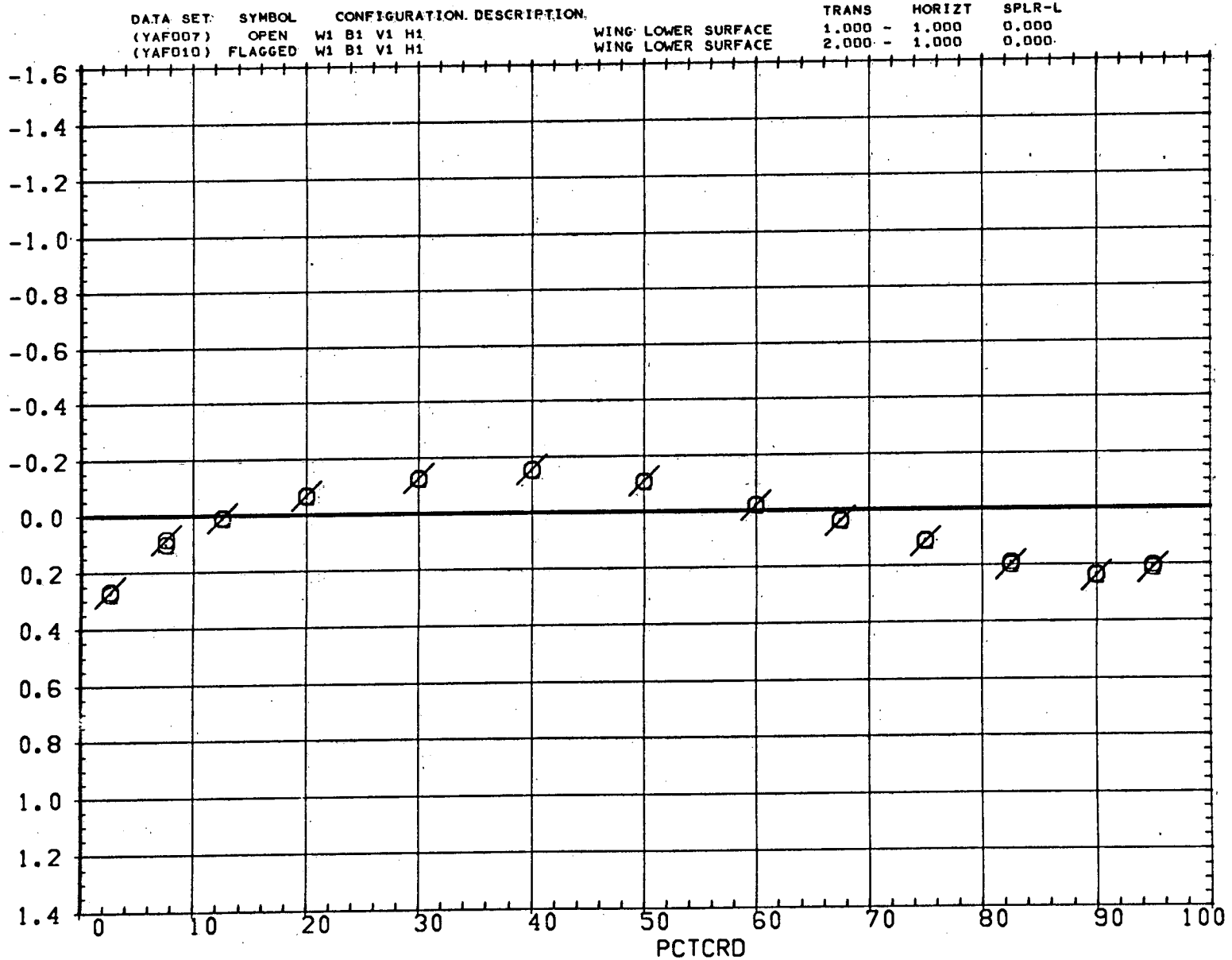

FIG. 24 EFFECT OF TRANS. STRIP LOCATION ON WING PRESSURE DIST.-WING LOWER SURF.

SYMBOL ALPHA BL MACH
 ○ 3.630 18.278 0.899

PARAMETRIC VALUES
 BETA 0.000 RN/L 4.000

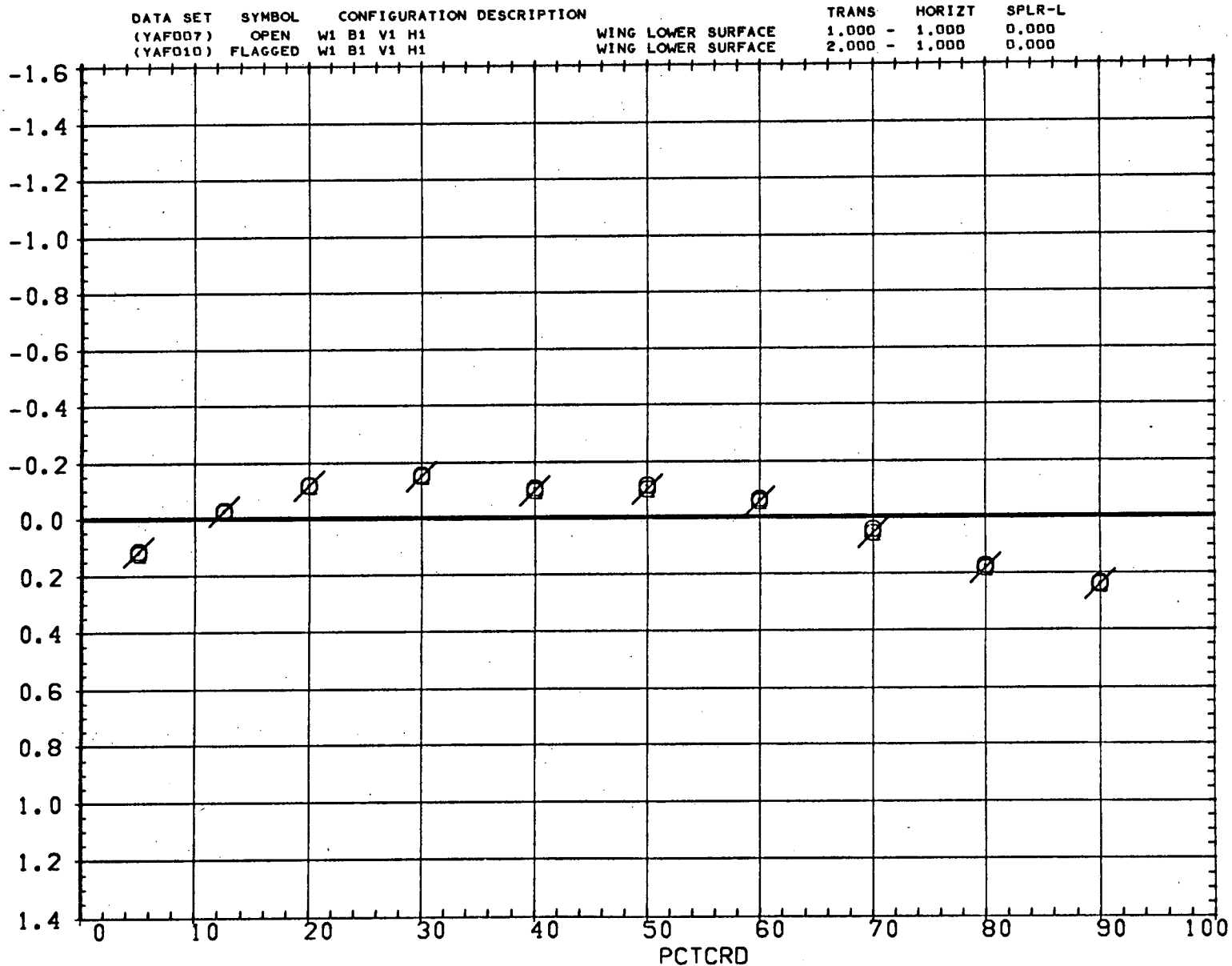

FIG. 24 EFFECT OF TRANS. STRIP LOCATION ON WING PRESSURE DIST.-WING LOWER SURF.

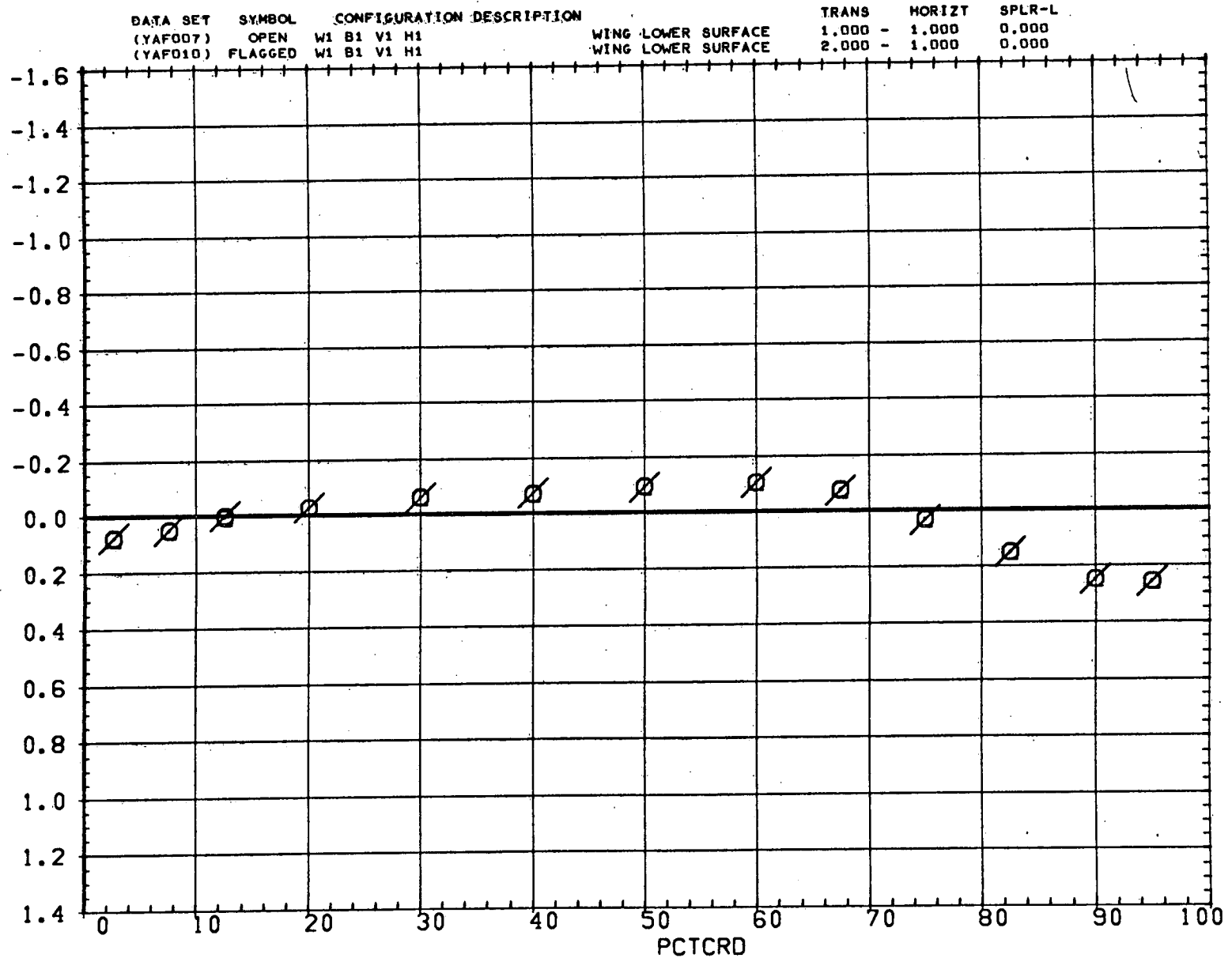

FIG. 24 EFFECT OF TRANS. STRIP LOCATION ON WING PRESSURE DIST.-WING LOWER SURF.

SYMBOL ALPHA BL MACH
 ○ 3.580 7.768 0.951

PARAMETRIC VALUES
 BETA 0.000 RN/L 4.000

DATA SET	SYMBOL	CONFIGURATION DESCRIPTION	TRANS	HORIZT	SPLR-L
(YAFD07)	OPEN	W1 B1 V1 H1	1.000	- 1.000	0.000
(YAFD10)	FLAGGED	W1 B1 V1 H1	2.000	- 1.000	0.000

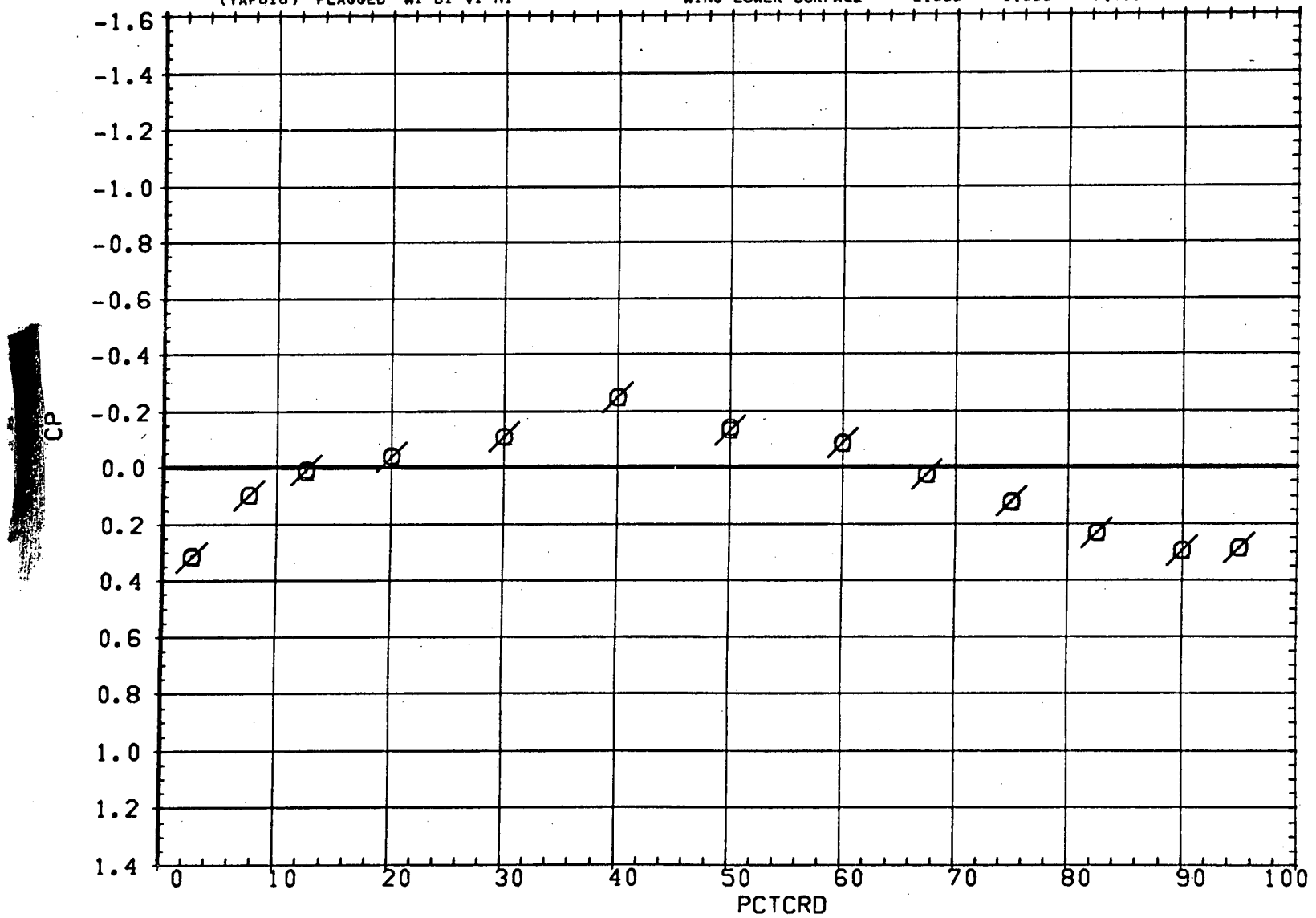

FIG. 24 EFFECT OF TRANS. STRIP LOCATION ON WING PRESSURE DIST.-WING LOWER SURF.

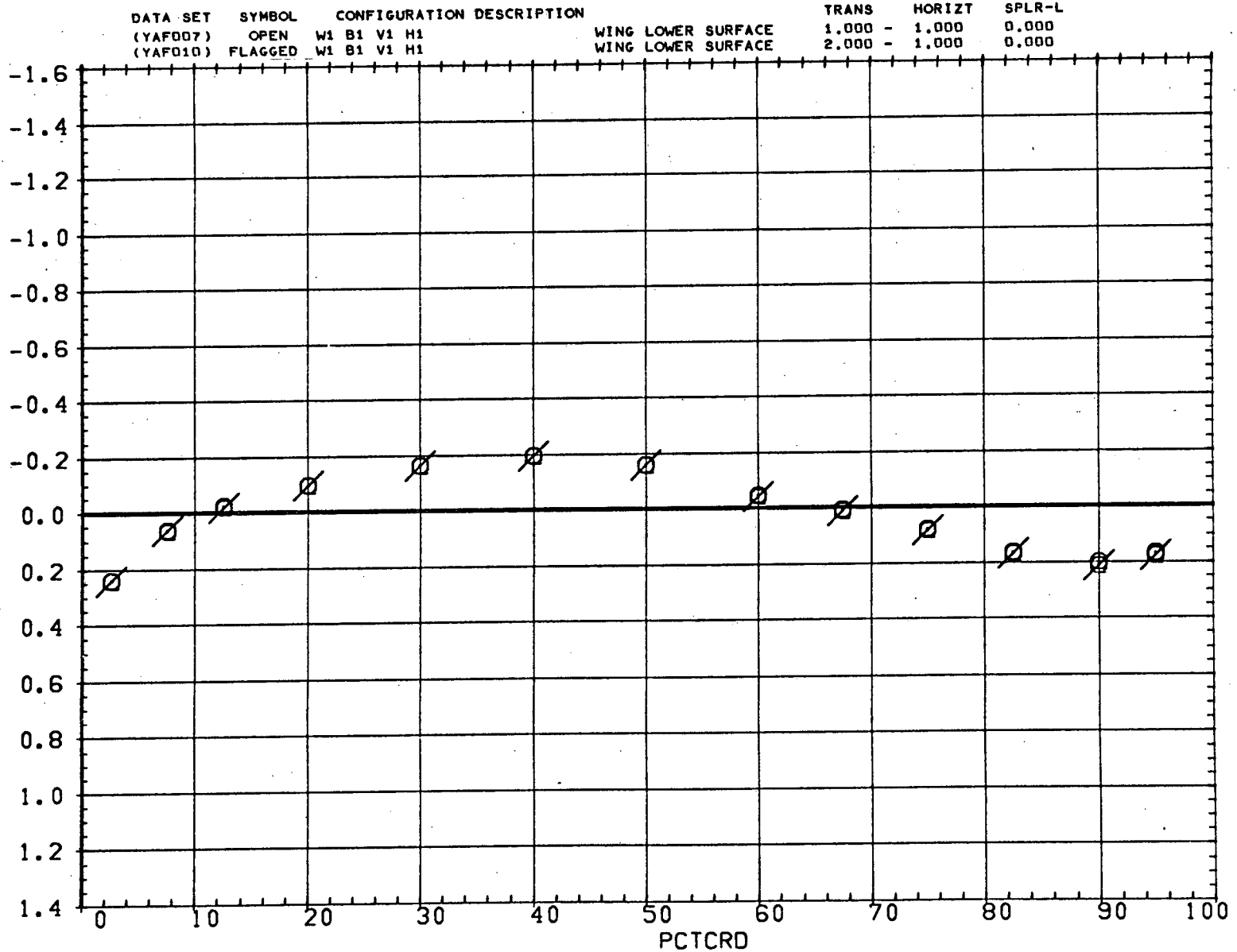

FIG. 24 EFFECT OF TRANS. STRIP LOCATION ON WING PRESSURE DIST.-WING LOWER SURF.

SYMBOL ALPHA BL MACH
 ○ 3.580 18.278 0.951

PARAMETRIC VALUES
 BETA 0.000 RN/L 4.000

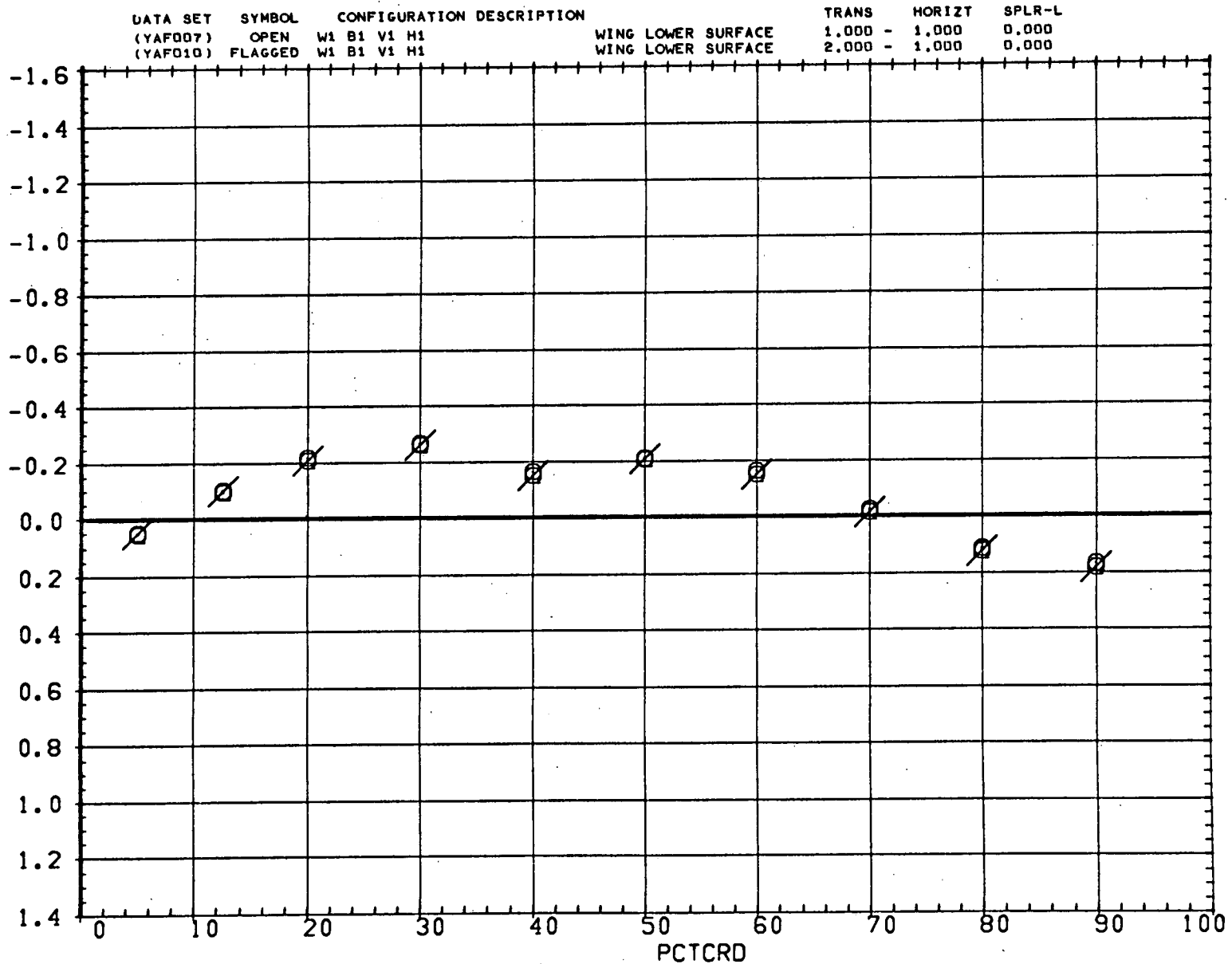

FIG. 24 EFFECT OF TRANS. STRIP LOCATION ON WING PRESSURE DIST.-WING LOWER SURF.

SYMBOL ALPHA BL MACH
 ○ 3.630 4.250 0.899

PARAMETRIC VALUES
 BETA 0.000 HORIZT - 1.000
 SPLR-L 0.000 TRANS 1.000
 RN/L 4.000

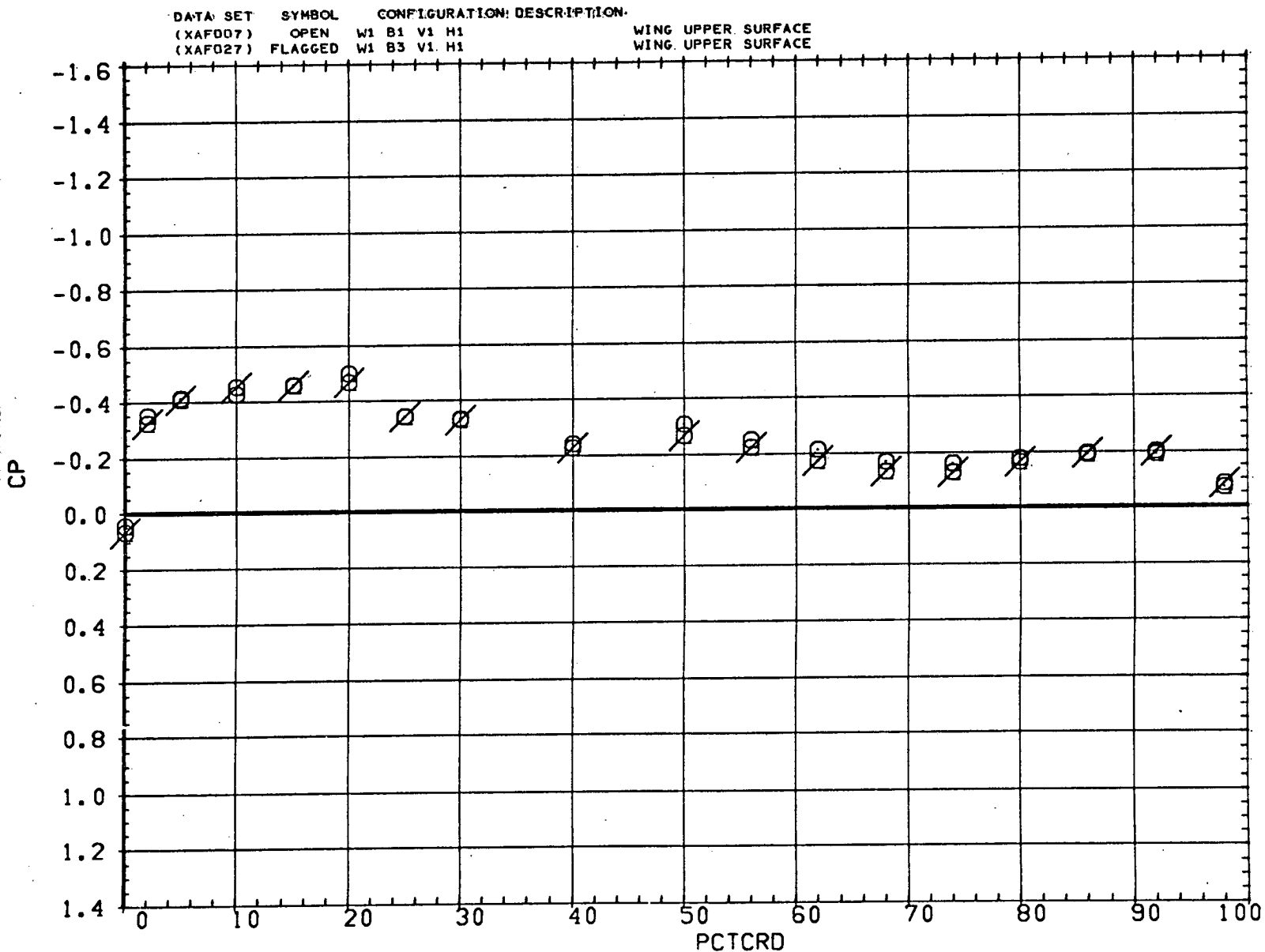

FIG. 25 EFFECT OF BODY AREA RULE ON WING PRESSURE DIST.-WING UPPER SURFACE

SYMBOL ALPHA BL MACH
 O 3.630 7.768 0.899

PARAMETRIC VALUES
 BETA 0.000 HORIZT - 1.000
 SPLR-L 0.000 TRANS 1.000
 RN/L 4.000

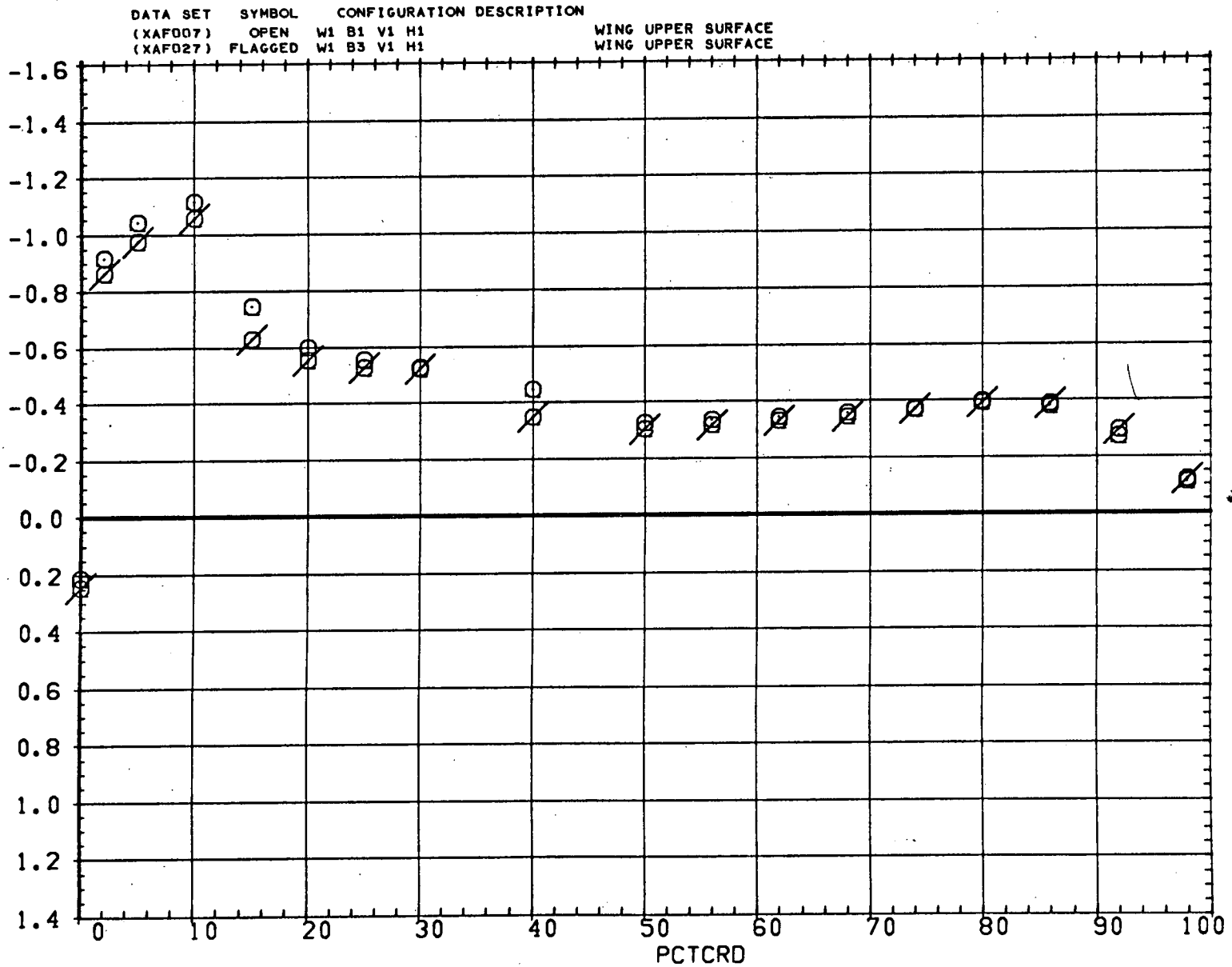

FIG. 25 EFFECT OF BODY AREA RULE ON WING PRESSURE DIST.-WING UPPER SURFACE

SYMBOL ALPHA BL MACH
 ○ 3.630 11.424 0.899

PARAMETRIC VALUES
 BETA 0.000 HORIZT - 1.000
 SPLR-L 0.000 TRANS 1.000
 RN/L 4.000

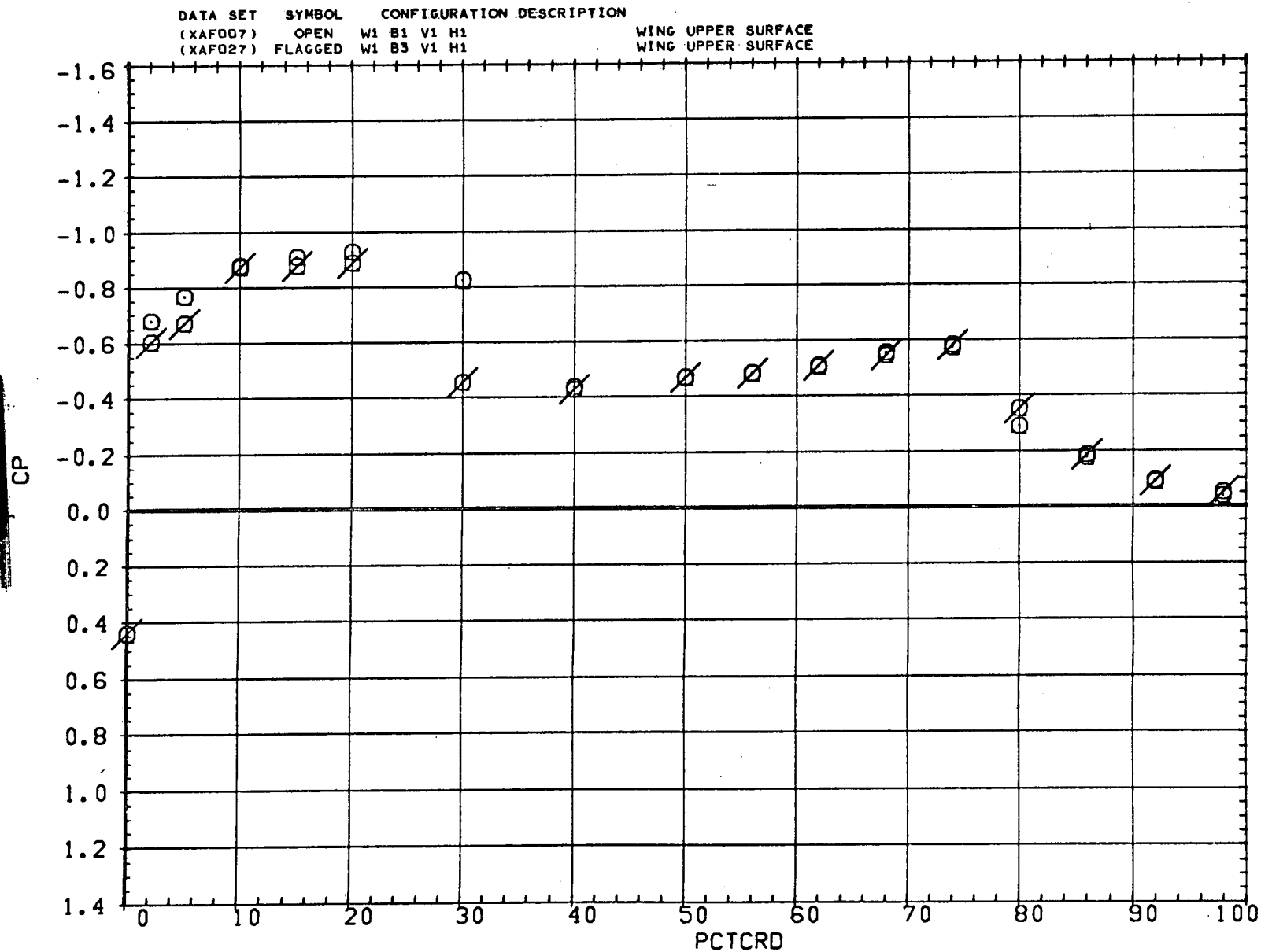

FIG. 25 EFFECT OF BODY AREA RULE ON WING PRESSURE DIST.-WING UPPER SURFACE

SYMBOL ALPHA BL MACH
 ○ 3.630 18.278 0.899

PARAMETRIC VALUES
 BETA 0.000 HORIZT - 1.000
 SPLR-L 0.000 TRANS 1.000
 RN/L 4.000

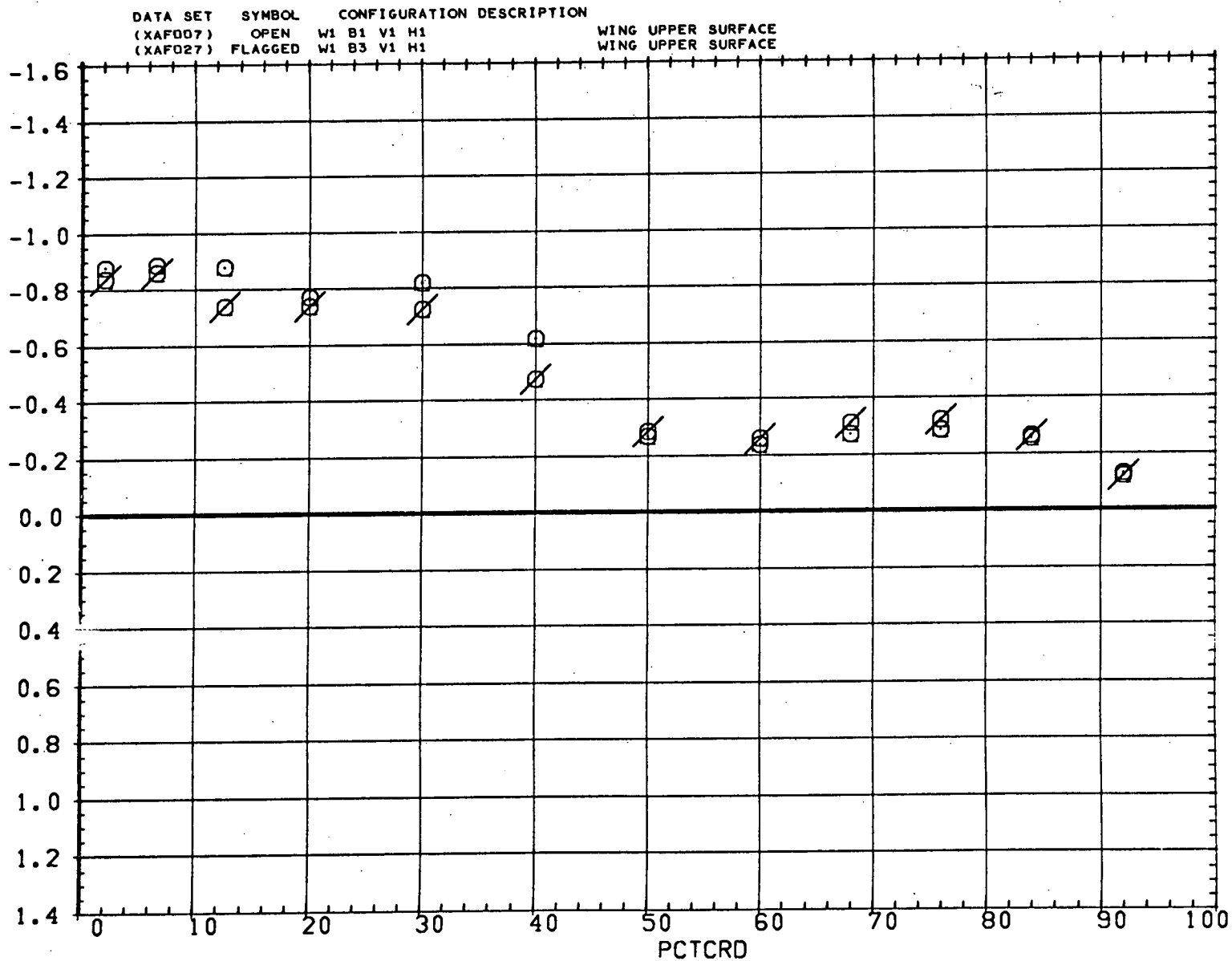

FIG. 25 EFFECT OF BODY AREA RULE ON WING PRESSURE DIST.-WING UPPER SURFACE

SYMBOL ALPHA BL MACH
 O 3.580 4.250 0.951

PARAMETRIC VALUES
 BETA 0.000 HORIZT - 1.000
 SPLR-L 0.000 TRANS 1.000
 RN/L 4.000

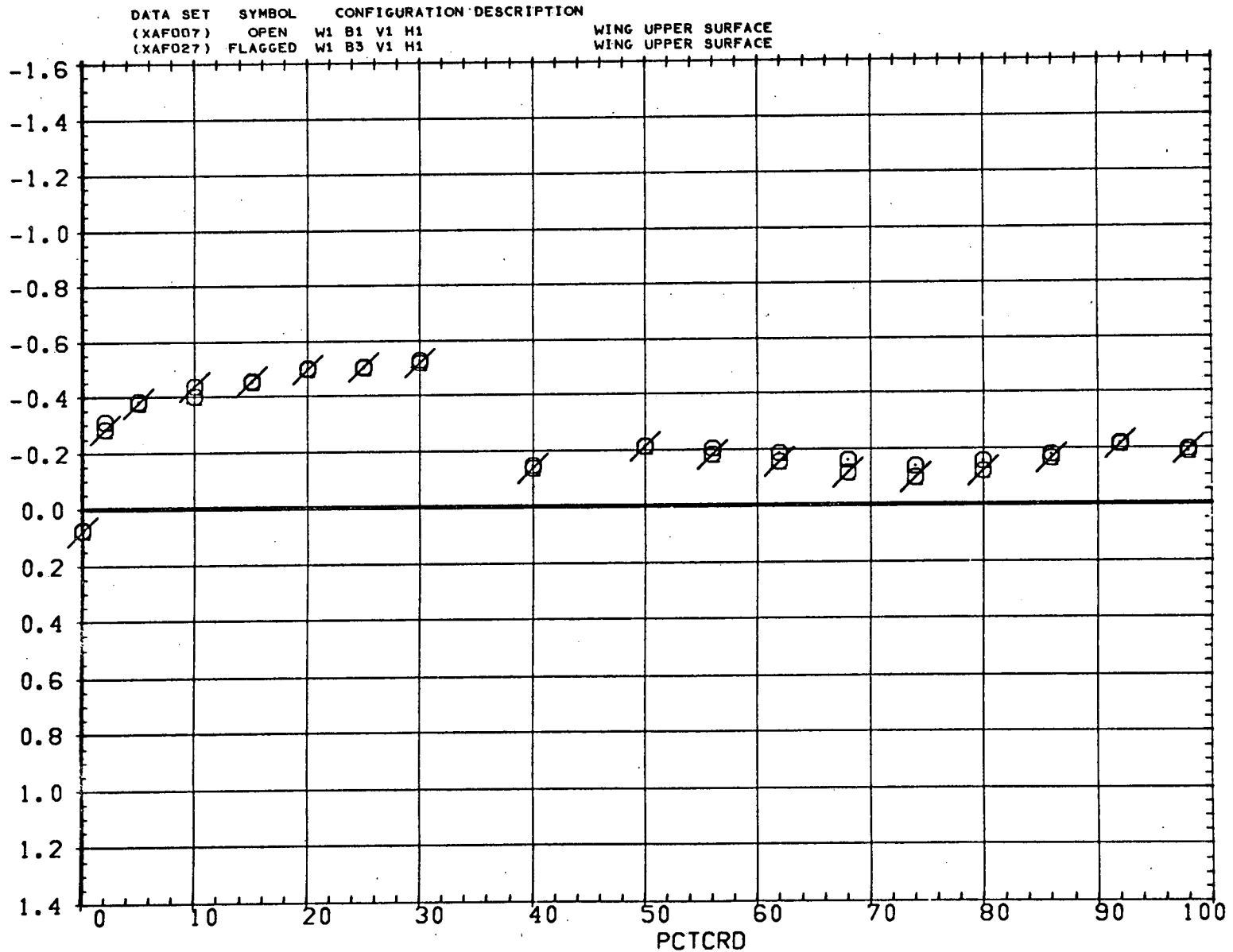

FIG. 25 EFFECT OF BODY AREA RULE ON WING PRESSURE DIST.-WING UPPER SURFACE

SYMBOL	ALPHA	BL	MACH
○	3.580	7.768	0.951

PARAMETRIC VALUES			
BETA	0.000	HORIZT	- 1.000
SPLR-L	0.000	TRANS	1.000
RN/L	4.000		

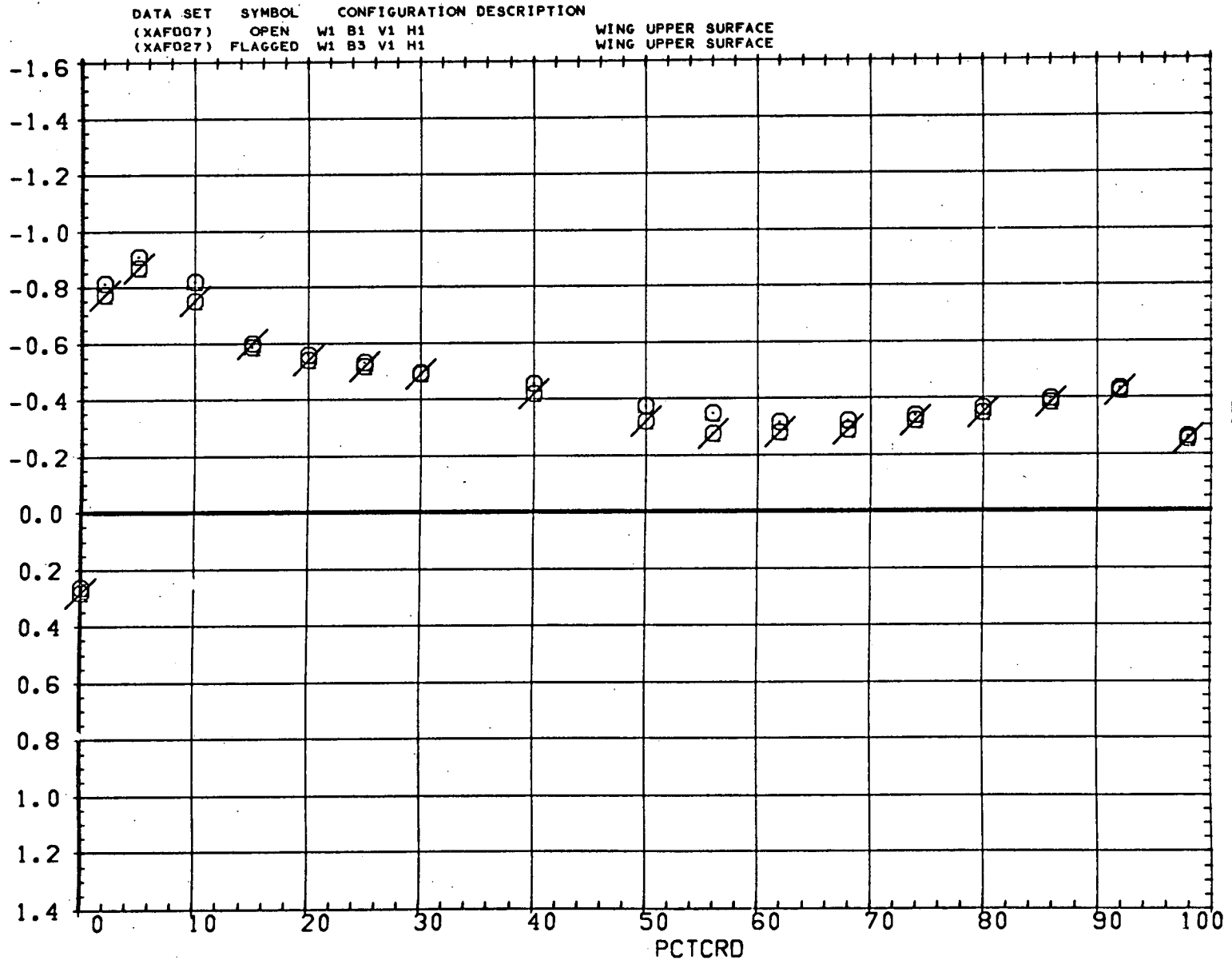

FIG. 25 EFFECT OF BODY AREA RULE ON WING PRESSURE DIST.-WING UPPER SURFACE

SYMBOL ALPHA BL MACH
 ○ 3.580 11.424 0.951

PARAMETRIC VALUES
 BETA 0.000 HORIZT - 1.000
 SPLR-L 0.000 TRANS 1.000
 RN/L 4.000

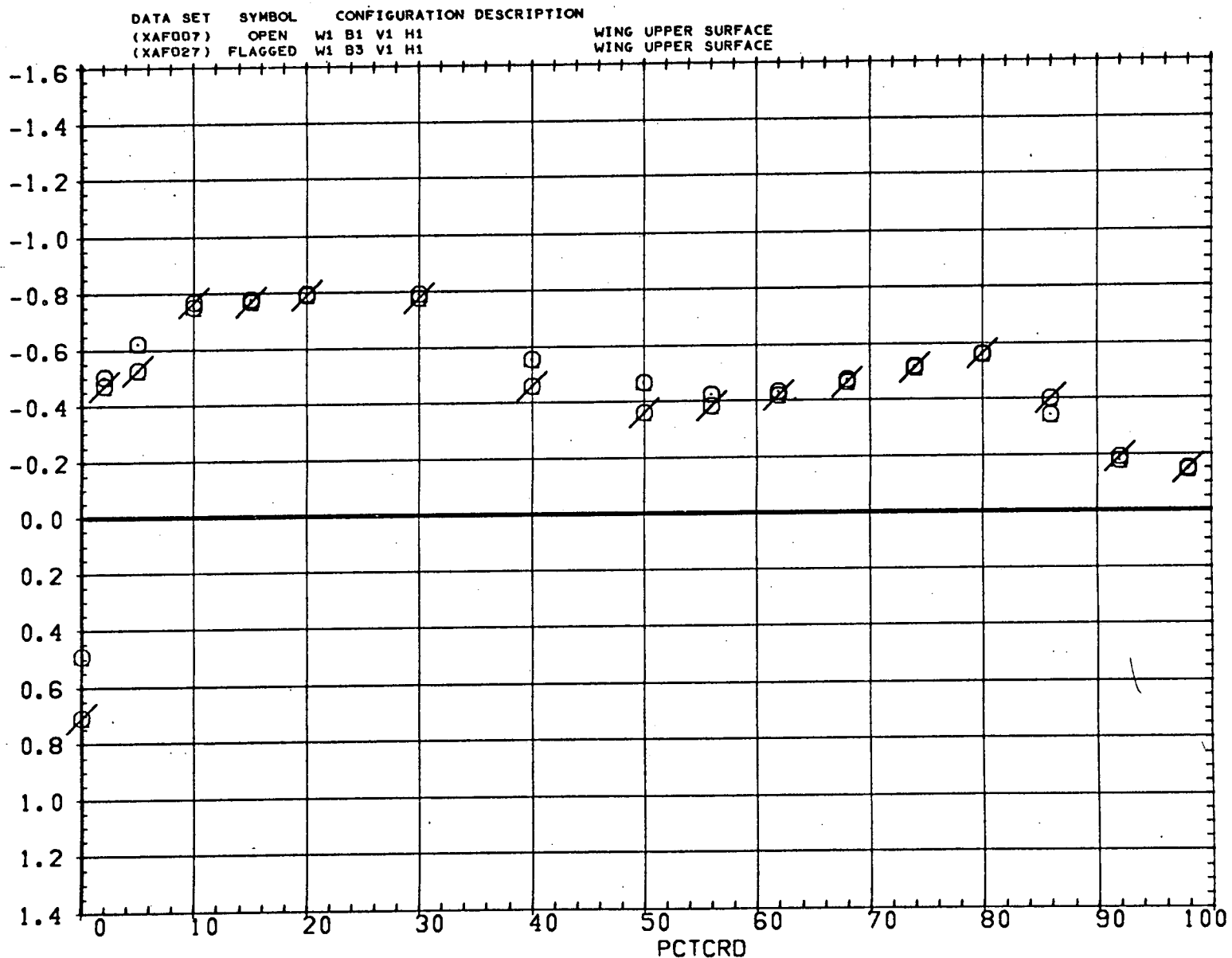

FIG. 25 EFFECT OF BODY AREA RULE ON WING PRESSURE DIST.-WING UPPER SURFACE

SYMBOL ALPHA BL MACH
 ○ 3.580 18.278 0.951

PARAMETRIC VALUES
 BETA 0.000 HORIZT - 1.000
 SPLR-L 0.000 TRANS 1.000
 RN/L 4.000

DATA SET SYMBOL CONFIGURATION DESCRIPTION
 (XAF007) OPEN W1 B1 V1 H1 WING UPPER SURFACE
 (XAFG27) FLAGGED W1 B3 V1 H1 WING UPPER SURFACE

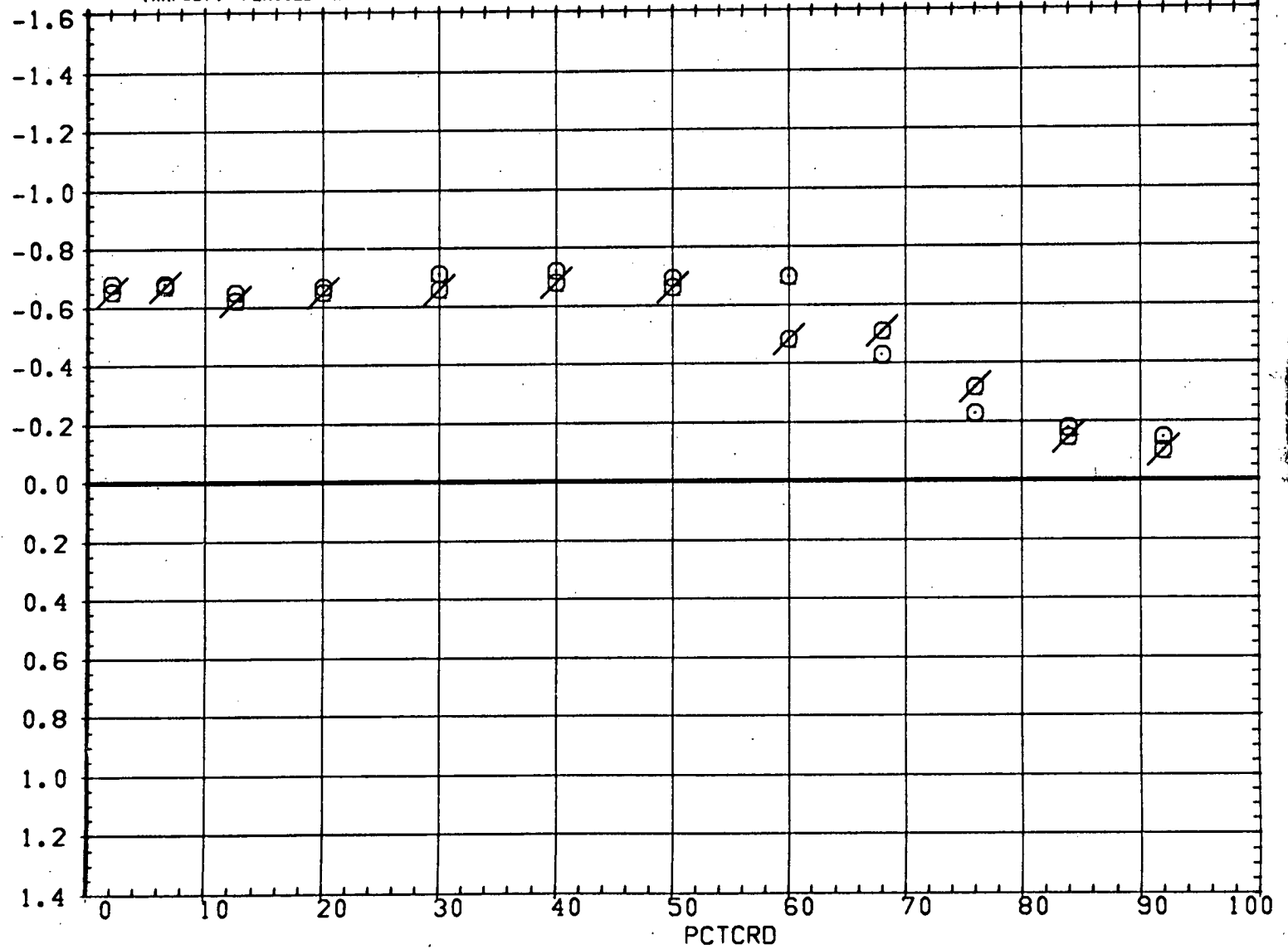

FIG. 25 EFFECT OF BODY AREA RULE ON WING PRESSURE DIST.-WING UPPER SURFACE

SYMBOL ALPHA BL MACH
 O 3.630 4.250 0.899

PARAMETRIC VALUES
 BETA 0.000 HORIZT - 1.000
 SPLR-L 0.000 TRANS 1.000
 RN/L 4.000

DATA SET SYMBOL CONFIGURATION DESCRIPTION
 (YAF007) OPEN W1 B1 V1 H1 WING LOWER SURFACE
 (YAF027) FLAGGED W1 B3 V1 H1 WING LOWER SURFACE

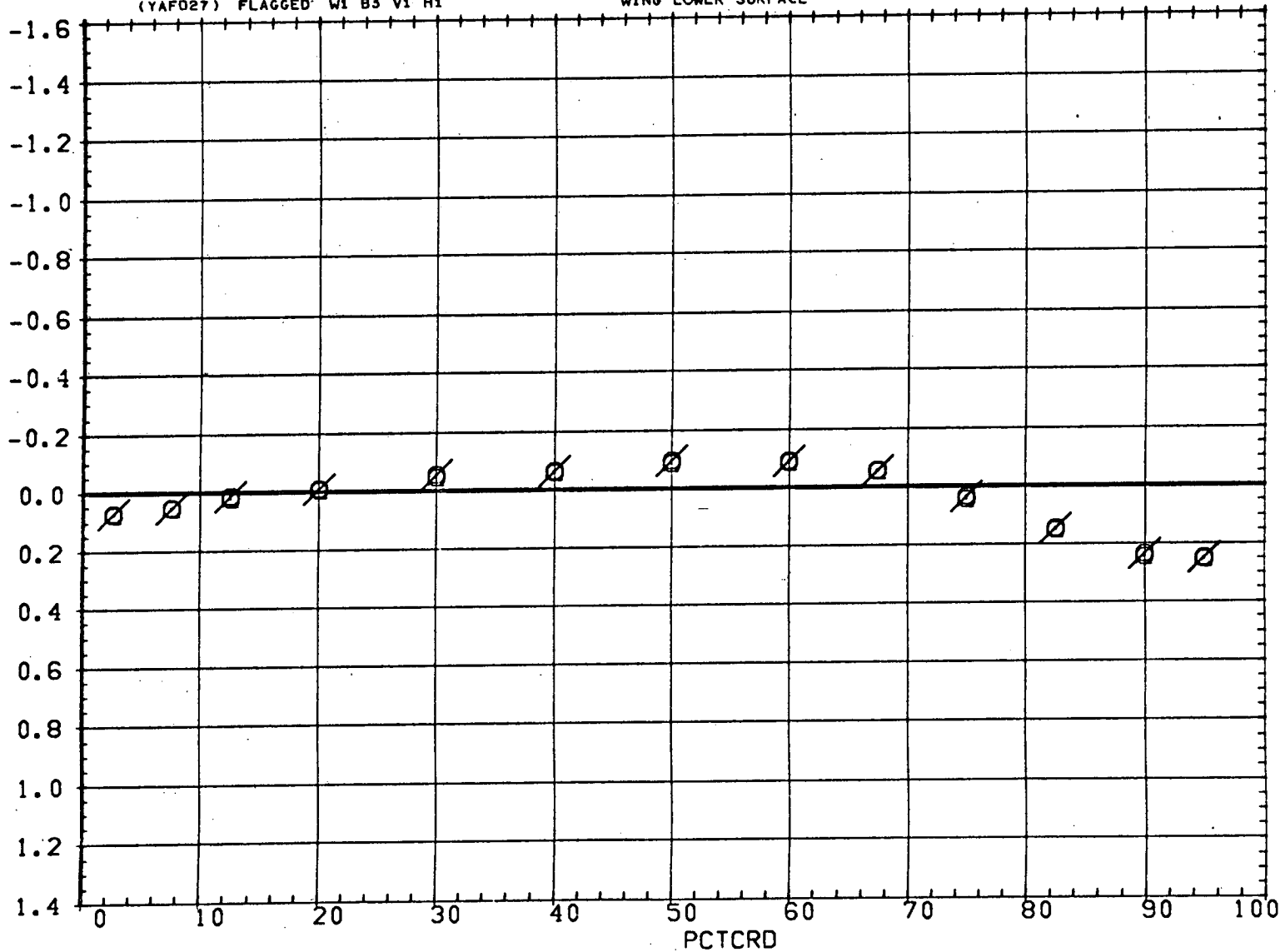

FIG. 26 EFFECT OF BODY AREA RULE ON WING PRESSURE DIST.-WING LOWER SURFACE

SYMBOL ALPHA BL MACH
 ○ 3.630 7.768 0.899

PARAMETRIC VALUES
 BETA 0.000 HORIZT - 1.000
 SPLR-L 0.000 TRANS 1.000
 RN/L 4.000

DATA SET SYMBOL CONFIGURATION DESCRIPTION
 (YAF007) OPEN W1 B1 V1 H1 WING LOWER SURFACE
 (YAF027) FLAGGED W1 B3 V1 H1 WING LOWER SURFACE

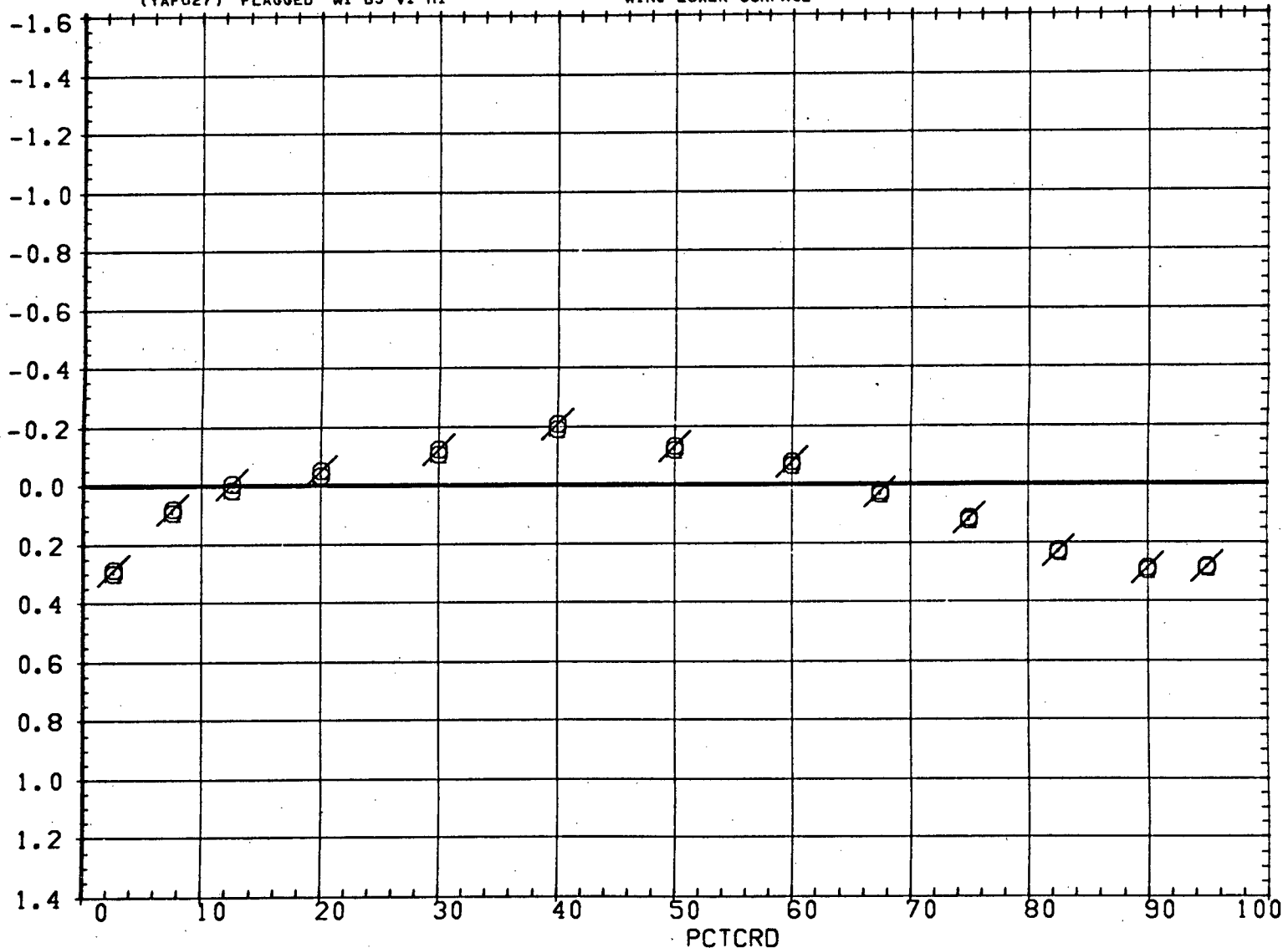

FIG. 26 EFFECT OF BODY AREA RULE ON WING PRESSURE DIST.-WING LOWER SURFACE

SYMBOL ALPHA BL MACH
 ○ 3.630 11.424 0.899

PARAMETRIC VALUES
 BETA 0.000 HORIZT - 1.000
 SPLR-L 0.000 TRANS 1.000
 RN/L 4.000

DATA SET SYMBOL CONFIGURATION DESCRIPTION
 (YAFO07) OPEN W1 B1 V1 H1 WING LOWER SURFACE
 (YAFO27) FLAGGED W1 B3 V1 H1 WING LOWER SURFACE

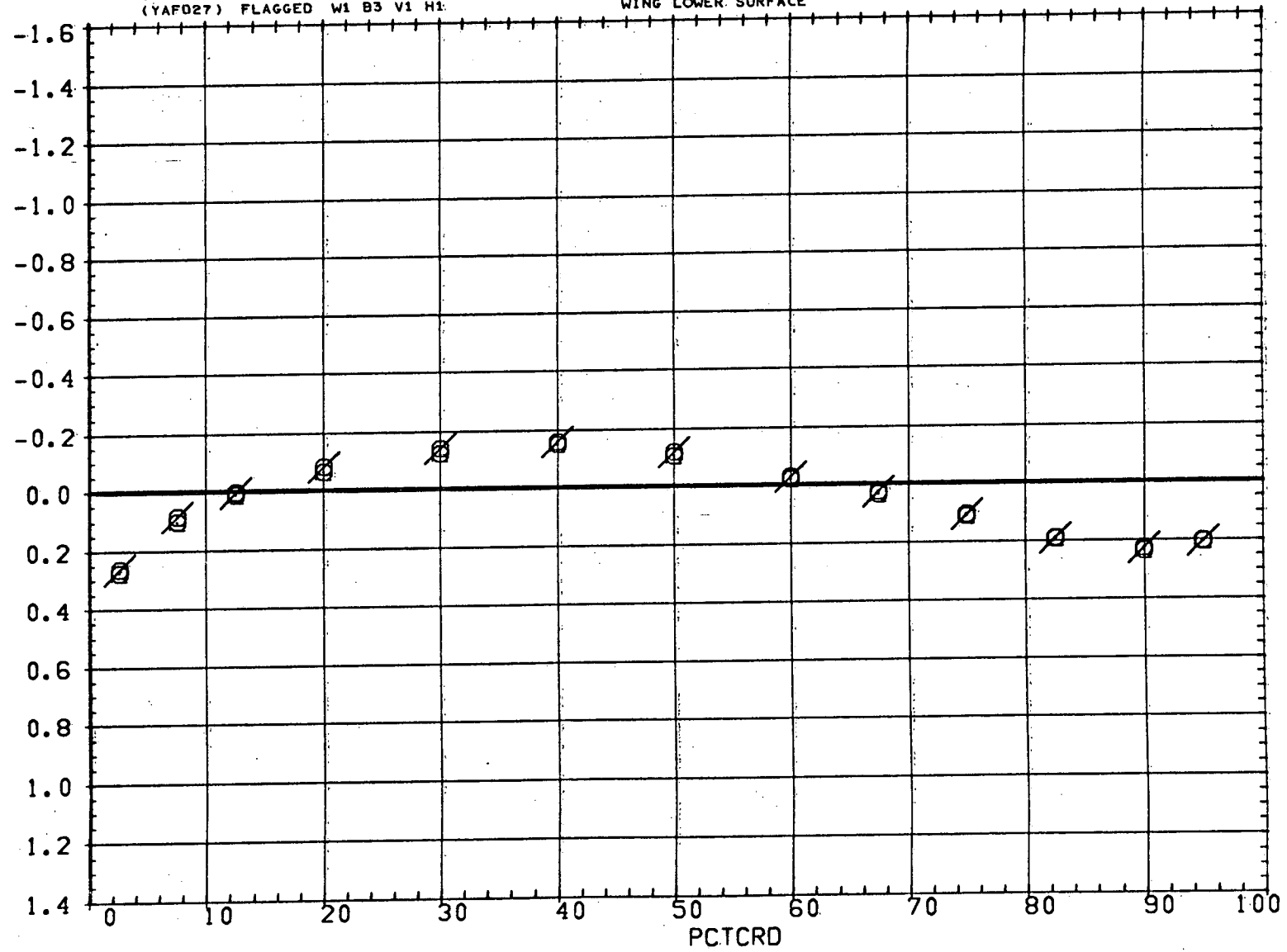

FIG. 26 EFFECT OF BODY AREA RULE ON WING PRESSURE DIST.-WING LOWER SURFACE

SYMBOL	ALPHA	BL	MACH
○	3.630	18.278	0.899

PARAMETRIC VALUES		
BETA	0.000	HORIZT - 1.000
SPLR-L	0.000	TRANS 1.000
RN/L	4.000	

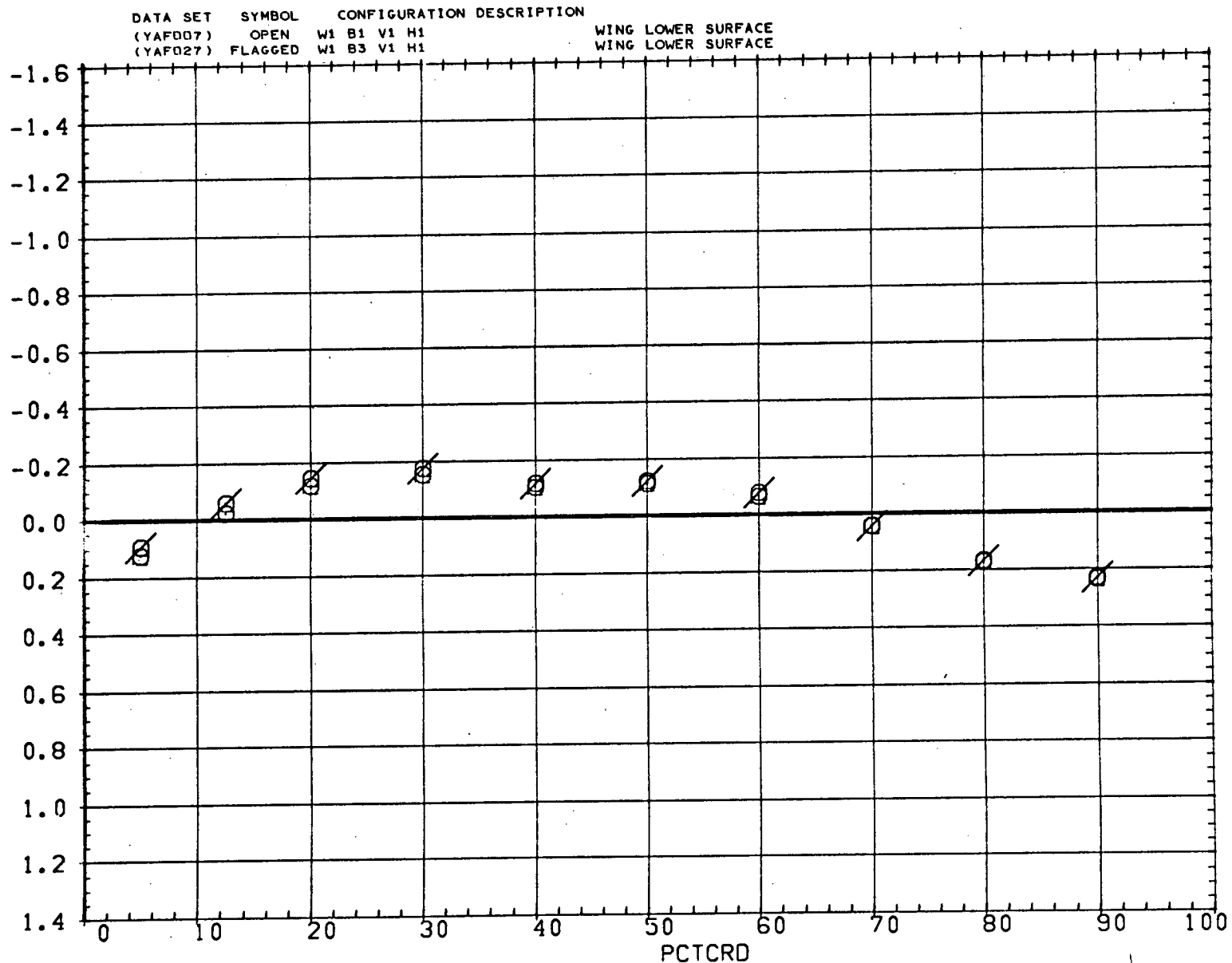

FIG. 26 EFFECT OF BODY AREA RULE ON WING PRESSURE DIST.-WING LOWER SURFACE

SYMBOL ALPHA BL MACH
 ○ 3.580 4.250 0.951

PARAMETRIC VALUES
 BETA 0.000 HORIZT - 1.000
 SPLR-L 0.000 TRANS 1.000
 RN/L 4.000

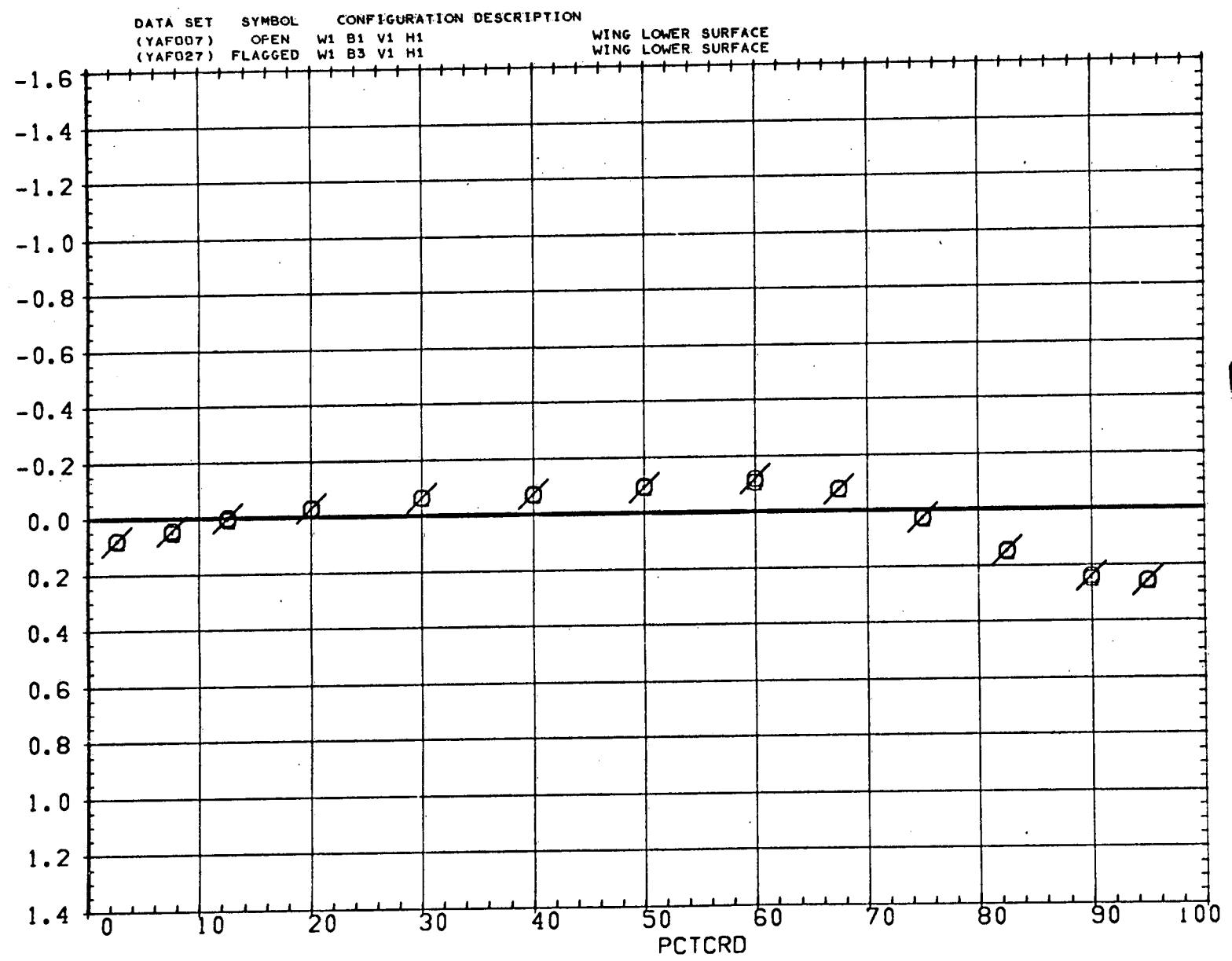

FIG. 26 EFFECT OF BODY AREA RULE ON WING PRESSURE DIST.-WING LOWER SURFACE

SYMBOL ALPHA BL MACH
 ○ 3.580 7.768 0.951

PARAMETRIC VALUES
 BETA 0.000 HORIZT - 1.000
 SPLR-L 0.000 TRANS 1.000
 RN/L 4.000

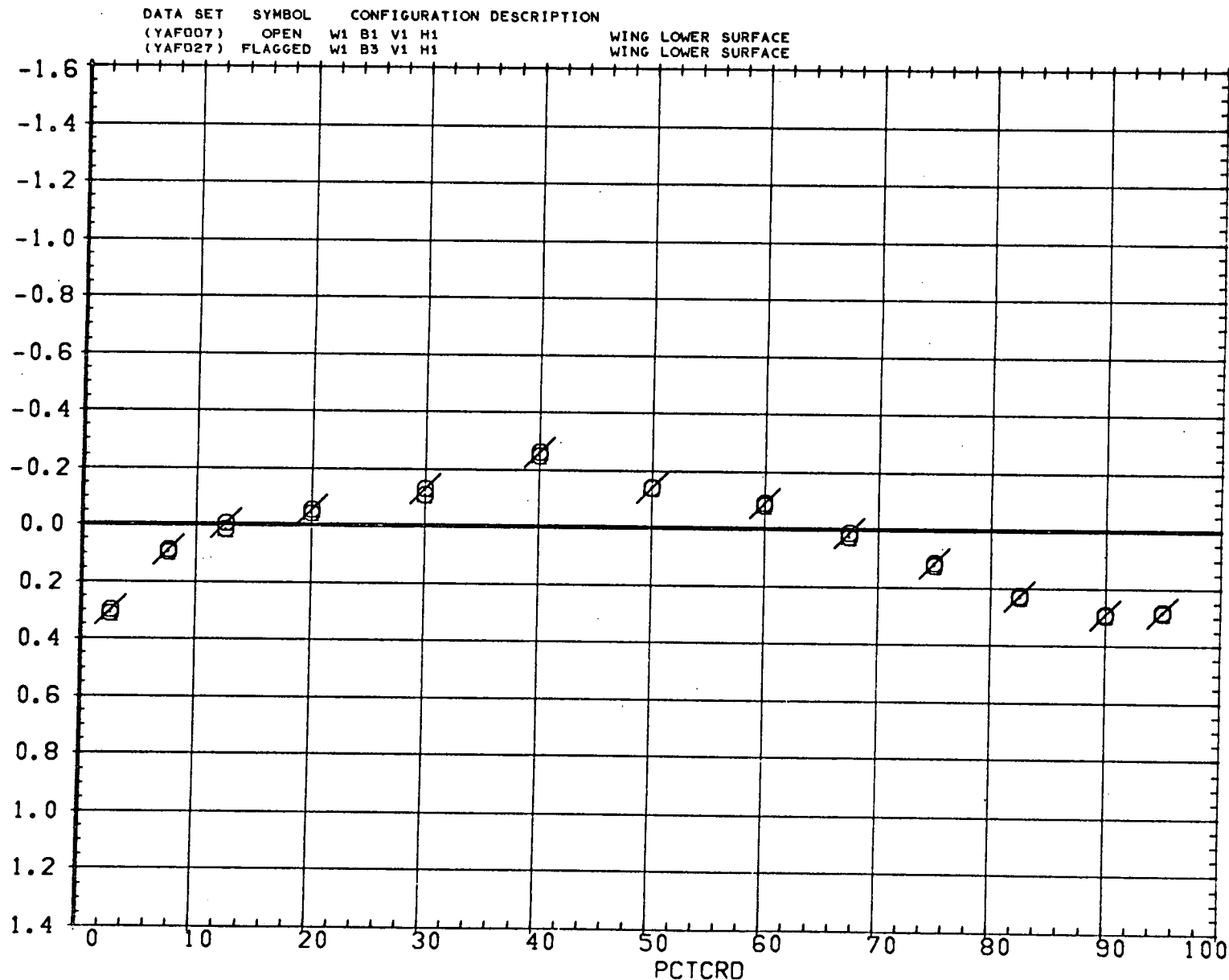

FIG. 26 EFFECT OF BODY AREA RULE ON WING PRESSURE DIST.-WING LOWER SURFACE

SYMBOL	ALPHA	BL	MACH
○	3.580	11.424	.0951

PARAMETRIC VALUES			
BETA	0.000	HORIZT	1.000
SPLR-L	0.000	TRANS	1.000
RN/L	4.000		

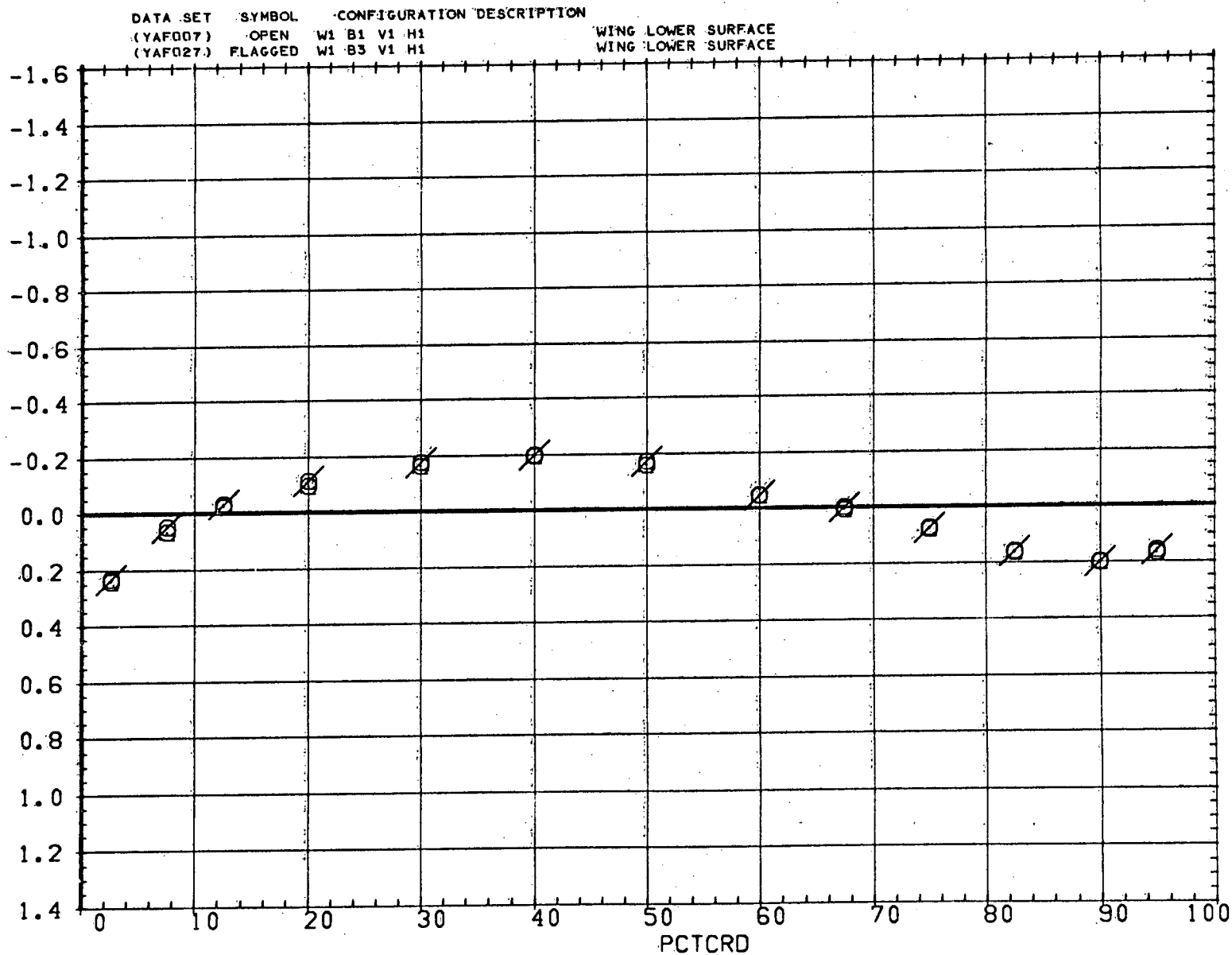

FIG. 26 EFFECT OF BODY AREA RULE ON WING PRESSURE DIST.-WING LOWER SURFACE

SYMBOL	ALPHA	BL	MACH
○	3.580	18.278	0.951

PARAMETRIC VALUES		
BETA	0.000	HORIZT - 1.000
SPLR-L	0.000	TRANS 1.000
RN/L	4.000	

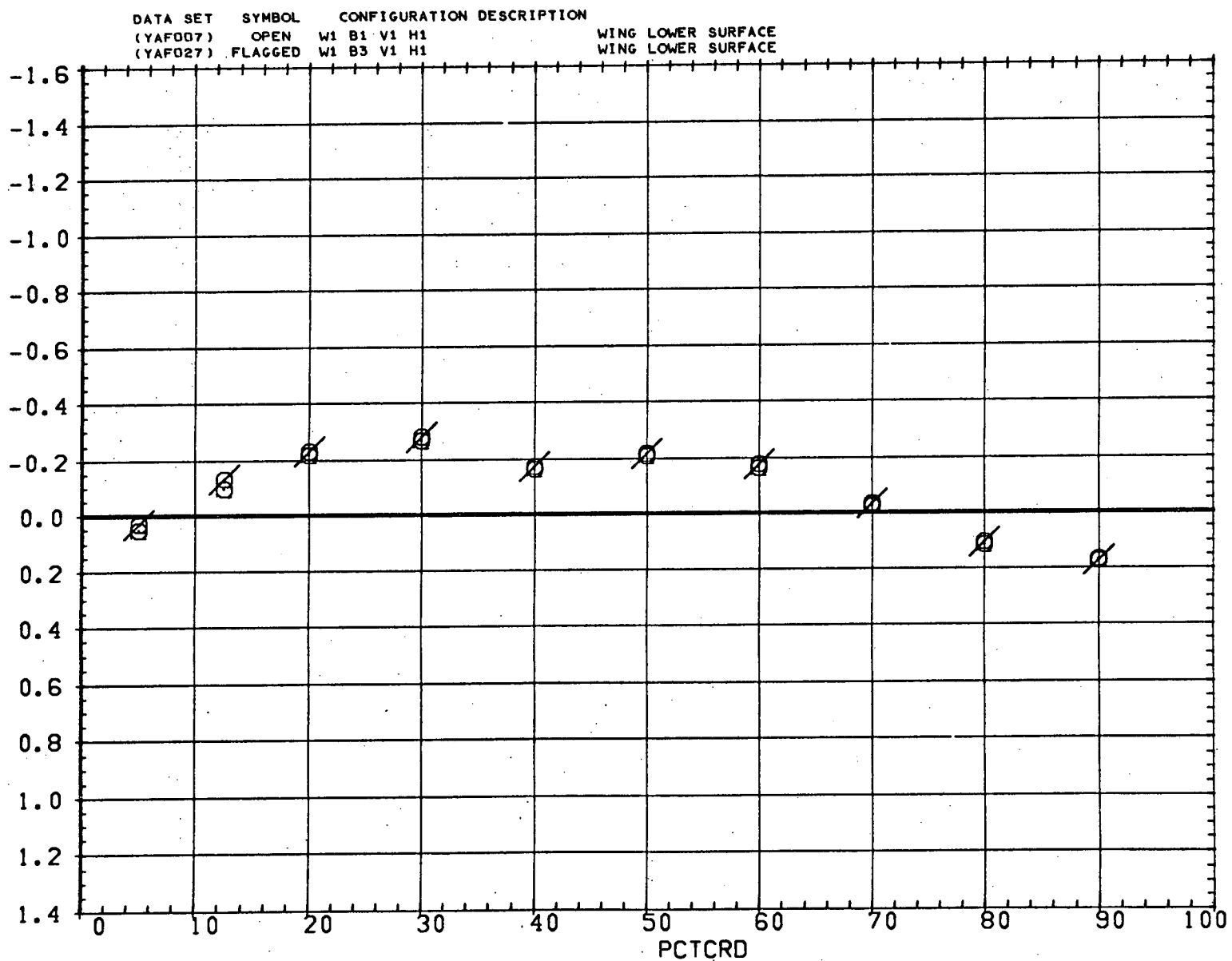

FIG. 26 EFFECT OF BODY AREA RULE ON WING PRESSURE DIST.-WING LOWER SURFACE

