



# RESEARCH MEMORANDUM

NACA INVESTIGATIONS OF ICING-PROTECTION SYSTEMS FOR  
TURBOJET-ENGINE INSTALLATIONS

By Uwe von Glahn, Edmund E. Callaghan, and Vernon H. Gray

Lewis Flight Propulsion Laboratory  
Cleveland, Ohio

NATIONAL ADVISORY COMMITTEE  
FOR AERONAUTICS  
WASHINGTON

May 2, 1951  
Declassified July 26, 1957

TABLE OF CONTENTS

	Page
S U M M A R Y . . . . .	1
I N T R O D U C T I O N . . . . .	1
E X P E R I M E N T A L T E C H N I Q U E S . . . . .	3
Flight . . . . .	3
Altitude wind tunnel . . . . .	4
Icing research tunnel . . . . .	4
I C I N G C H A R A C T E R I S T I C S O F T U R B O J E T -	
E N G I N E I N S T A L L A T I O N S . . . . .	4
General Considerations . . . . .	4
Meteorological factors . . . . .	4
Geometric and aerodynamic factors . . . . .	5
Typical Icing of Components . . . . .	6
Compressor-inlet screen . . . . .	6
Inlet guide vanes . . . . .	6
Inlet lips, accessory housing, and islands . . . . .	7
Compressor blading . . . . .	7
E F F E C T O F I C I N G O N T U R B O J E T - E N G I N E	
P E R F O R M A N C E . . . . .	7
Pressure losses associated with icing . . . . .	8
Effect of icing on axial-flow type turbojet-engine performance . . . . .	8
Effect of icing on centrifugal-flow-type turbojet-engine	
performance . . . . .	9
Damage caused by ice . . . . .	10
I C I N G - P R O T E C T I O N M E T H O D S . . . . .	10
SURFACE HEATING . . . . .	10
General Considerations . . . . .	10
Heating Requirements for Inlet Guide Vanes . . . . .	13
Gas heating of vanes . . . . .	13
Continuous electrical heating of vanes . . . . .	15
Cyclical electric de-icing of vanes . . . . .	16
Eddy-current heating of vanes . . . . .	17
HOT-GAS-BLEEDBACK SYSTEM . . . . .	17
Heating requirements . . . . .	19
Calculation of bleedback as function of gas temperature . . . . .	19
Orifice configuration and temperature distribution . . . . .	20
Pressure losses associated with bleedback system . . . . .	20
Effect of bleedback on engine performance . . . . .	21

INERTIA-SEPARATION INLETS . . . . .	22
Alternate-Duct System . . . . .	22
Submerged-Inlet System . . . . .	23
SUMMARY OF RESULTS . . . . .	24
Surface Heating . . . . .	24
Hot-Gas Bleedback . . . . .	25
Inertia-Separation Inlets . . . . .	25
CONCLUDING REMARKS AND RECOMMENDATIONS . . . . .	25
APPENDIX - SYMBOLS . . . . .	28
REFERENCES . . . . .	29
FIGURES . . . . .	33 to 69

NATIONAL ADVISORY COMMITTEE FOR AERONAUTICS

RESEARCH MEMORANDUM

NACA INVESTIGATIONS OF ICING-PROTECTION SYSTEMS FOR  
TURBOJET-ENGINE INSTALLATIONS

By Uwe von Glahn, Edmund E. Callaghan, and Vernon H. Gray

S U M M A R Y

Investigations have been made in flight and in wind tunnels to determine which components of turbojet installations are most critical in icing conditions, and to evaluate several methods of icing protection. From these studies, the requirements necessary for adequate icing protection and the consequent penalties on engine performance can be estimated.

Because investigations have indicated that the compressor-inlet screen constitutes the greatest icing hazard and is difficult to protect, complete removal or retraction of the screen upon encountering an icing condition is recommended. In the absence of the screen, the inlet guide vanes of an axial-flow-type turbojet engine constitute the greatest danger to engine operation in an icing condition; a centrifugal-type engine, on the other hand, is relatively unsusceptible to icing once the screen has been removed.

Of the three icing-protection systems investigated, surface heating, hot-gas bleedback, and inertia-separation inlets, only the first two offer an acceptable solution to the problem of engine icing protection. Surface heating, either by gas heating or electrical means, appears to be the most acceptable icing-protection method with regard to performance losses. Hot-gas bleedback, although causing undesirable thrust losses, offers an easy means of obtaining icing protection for some installations. The final choice of an icing-protection system depends, however, on the supply of heated gas and electrical power available and on the allowable performance and weight penalties associated with each system.

I N T R O D U C T I O N

The development of high-performance turbojet engines and the advent of all-weather turbojet-propelled aircraft have necessitated

extensive research programs to determine methods for icing protection of the various components of such engine installations. Not only is the inlet ducting of a turbojet-engine installation subject to icing, but, more important, the internal elements such as the compressor-inlet screen, the inlet guide vanes, and the compressor blading are also subject to icing. Ice formations on the internal elements seriously affect the operation and the performance characteristics of a turbojet engine. The ice formations on the screen and the inlet guide vanes reduce the compressor-inlet area and increase the pressure losses. In addition, ice formations on the compressor blading may decrease the compressor efficiency and thus further reduce the pressure available in the engine. The over-all pressure and mass-flow losses of the entire turbojet-engine installation markedly decrease the propulsive thrust, particularly at high flight Mach numbers (reference 1). Serious icing of a turbojet-engine installation may render the engine inoperative in a matter of minutes.

The scope of NACA turbojet-engine icing investigations to date has been threefold: (1) to study the effect of icing on turbojet-engine performance, (2) to evaluate the feasibility and the practicability of several methods for protecting turbojet engines from icing, and (3) to determine the effects of these ice-protection methods on engine performance under both dry and icing conditions. The investigations were carried out at the NACA Lewis laboratory in natural-flight icing conditions and under simulated icing conditions using a water-spray system in the altitude wind tunnel and the icing research tunnel.

The icing investigations in natural-flight icing conditions were confined to the determination of the effect of icing on turbojet-engine performance. Investigations in the altitude wind tunnel included the three phases of icing investigations previously mentioned. Studies in the icing research tunnel were primarily concerned with several methods of ice protection for turbojet-engine inlets and an evaluation of the effects of these methods on engine performance.

Three basic methods have been advanced for the icing protection of turbojet engines:

(1) Local heating of all surfaces subject to icing (fig. 1). Surface heating may be accomplished by (a) passing heated gases through passages within the component walls, (b) internal or external electrical heating pads or films, and (c) electrical eddy currents induced by a pulsating magnetic field in the elements to be protected.

(2) Addition of heat to the entire mass of air passing through the inlet (fig. 2), which raises the inlet-air temperature above

freezing. By injecting hot gas into the air stream at the inlet, the engine and most components in the inlet duct are afforded icing protection in one operation.

(3) Inertia separation of supercooled water droplets out of the engine-inlet air stream by special inlet and duct design (fig. 3). The duct design consists of a single inlet opening followed by a main duct for nonicing operation and an alternate duct with sharply curved passages through which air, with a greatly reduced water content in an icing condition, can pass to the compressor inlet.

A summary based on the collective results of all NACA investigations to date on turbojet-engine ice protection is presented herein.

#### E X P E R I M E N T A L   T E C H N I Q U E S

Icing investigations of turbojet engines and inlets were conducted at the NACA Lewis laboratory in the following three phases:

Flight. - Two flight investigations of the effect of icing on turbojet engines were conducted, one using a centrifugal-flow-type engine and the other using an axial-flow-type engine. In the first flight investigation (unpublished), a centrifugal-flow-type turbojet engine with a static-thrust rating of 1600 pounds at sea level and a double-entry inlet was installed in the waist compartment of a large four-engine bomber-type aircraft (fig. 4). An air inlet for the turbojet engine was installed on top of the fuselage and the exhaust gases were expelled from the tail portion of the aircraft. The turbojet engine was instrumented to provide data for determining specific fuel consumption, turbine-outlet temperatures, and air flow. The investigation was conducted in flight under mild natural icing conditions; consequently, the liquid-water content of the air was augmented by means of a battery of spray nozzles located ahead of the engine air scoop atop the fuselage.

In the second flight investigation (references 2 to 4), an axial-flow-type engine of approximately 3000-pound rated sea-level static thrust was studied. The engine was mounted below the wing of a large four-engine bomber-type aircraft (fig. 5) and was instrumented to determine the effects of icing on engine performance. During the investigation, no compressor-inlet screen was used. Photographs of engine icing in flight were obtained with a camera so located that it could be swung into position to obtain pictures of the engine inlets. All investigations with this installation were conducted in natural flight icing conditions. The aircraft was also provided with equipment to evaluate the meteorological conditions prevailing throughout the flights.

Altitude wind tunnel. - An axial-flow-type engine similar to that used in the second flight investigation was mounted in a wing nacelle in the test section of the altitude wind tunnel (reference 5). This engine was fitted with an experimental hot-gas bleedback ice-protection system. The engine was instrumented to provide data for evaluating the performance of the engine and the hot-gas bleedback system in icing conditions. The investigations were conducted at various pressure altitudes up to 20,000 feet in simulated-icing conditions using spray nozzles.

Icing research tunnel. - Various ice-protection methods were evaluated in the 6- by 9-foot test section of the icing research tunnel with scaled research mockups of turbojet-engine-inlet components. Icing conditions with air temperatures as low as  $-30^{\circ}$  F were obtained at air speeds up to 300 miles per hour and pressure altitudes below 3500 feet. Cloud droplet sizes and liquid-water contents in the tunnel were measured by the rotating-multicylinder method and were in the range of natural icing conditions. All models were instrumented to obtain pertinent pressure and temperature data.

## ICING CHARACTERISTICS OF TURBOJET - ENGINE INSTALLATIONS

### General Considerations

All surfaces of a jet-engine installation that are exposed to direct impingement of water droplets may require icing protection (fig. 1). The engine and inlet components that are subject to icing are therefore inlet lips, accessory housing dome, islands and island fairings, compressor-inlet screen, inlet guide vanes, and compressor blading. In addition, other surfaces may require icing protection, such as duct-splitter plates, openings for boundary-layer bleedoff and accessory-cooling purposes, and curved inlet-duct walls subject to impingement caused by water separation from the inlet air stream.

Meteorological factors. - The principal meteorological factors that contribute to icing are liquid-water content, air temperature, and droplet size. The rapidity with which ice builds up on the engine components and the time required to render the engine inoperative depend on the liquid-water content. The type of ice formation that occurs depends on the air temperature and the droplet size. Generally, the ice formations may be separated into two categories: (1) double-peaked glaze-ice formations in which the outer edges protrude laterally and forward into the air stream (fig. 6), and (2) wedge-shaped rime-ice formations, which build forward from the impingement area. Glaze icing

is usually associated with air temperatures near freezing and relatively large droplet sizes. Rime icing is usually associated with low air temperatures and small droplet sizes.

The known meteorological factors conducive to aircraft icing are arranged in several classifications in reference 6. The range of possible meteorological factors in each classification is discussed and specific values are recommended for the analysis of the various aircraft components.

Geometric and aerodynamic factors. - The paths of droplets are primarily influenced by the flow field about a body and the relative size of the droplets and the body. Because the flow field is determined by the shape of the body and the relative motion of the air stream, the shape greatly affects the extent of icing. Also, as the size of the body decreases relative to that of the droplet, the local icing rate is increased.

Icing of a turbojet engine is therefore affected by the aerodynamic characteristics of the engine installation. The number of water droplets entering the engine inlet is influenced by the inlet-velocity ratio (ratio of inlet-air velocity to the free-stream velocity), as illustrated in figure 7. The droplets contained within the limiting droplet trajectories enter the inlet whereas all droplets outside the limiting trajectories either impinge on the inlet body or pass around it. When the inlet-velocity ratio is less than 1.0, the area contained within the limiting droplet trajectories is greater than the area within the lip stagnation streamlines; hence the liquid-water content in the inlet is increased above that in the ambient air (fig. 7(a)). For an inlet-velocity ratio greater than 1.0, the area within the limiting trajectories is less than the area within the stagnation streamlines; hence the liquid-water content in the inlet is decreased below that in the ambient air (fig. 7(b)). Because of the scooping effect and the divergence of the streamlines when the inlet-velocity ratio is less than 1.0, icing on the inlet-duct walls may be expected.

The temperature-rise characteristics of each compressor stage and the adiabatic temperature change caused by flight speed influence the distance into the engine that ice formations occur. Obviously, as the temperature on the engine surfaces reaches a point above the freezing level, no ice will form.



## Typical Icing of Components

The icing tolerance of a turbojet engine is limited by the component having the smallest and most closely spaced elements. A compressor-inlet screen therefore constitutes the greatest icing hazard. In the absence of the compressor-inlet screen, the inlet guide vanes become the critical component. Examples of typical icing of turbojet-engine components are described in the following sections.

Compressor-inlet screen. - Icing of a circumferential compressor-inlet screen obtained during the investigation reported in reference 7 is shown in figure 8(a). Because the water-collection efficiency of the screen wires was extremely high and because they were closely spaced, the screen was rapidly blocked with ice. The rapid blocking of the screen will quickly reduce the efficiency and the air flow of an engine to such a point that engine operation may not continue for a sufficient length of time to start an icing-protection system.

Icing of a wire-mesh compressor-inlet screen of the type commonly used in centrifugal-type turbojet engines (unpublished data) is shown in figure 8(b). The screen shown in figure 8(b) was located at the forward entry to the compressor impeller. From the study conducted, the rear screen was found to be less susceptible to icing because of its proximity to the warm portions of the combustion-chamber adaptors. The water content in the air at the compressor-inlet screen was reduced by deposition of ice on the duct walls and the structural members of the engine.

Inlet guide vanes. - Icing on inlet guide vanes occurs on the vane leading edges and along the concave surfaces as far as the trailing edges, as shown in figure 9. This photograph was taken during an icing flight (reference 4) and illustrates a typical glaze-ice formation. The ice formations shown obstructed a large portion of the air passage to the compressor, especially at the upper half of the compressor inlet. The nature of the ice in figure 9 indicates that ice has shed from some of the vanes and islands. The shedding of ice formations is a complex function of meteorological conditions, aerodynamic forces, and vibrational characteristics of the engine installation.

The extent of blockage of the compressor inlet by guide-vane icing is determined by the spacing of the vanes. Spacing of the guide vanes somewhat closer than shown in figure 9 would apparently result in bridging of ice between adjacent vanes, occurring first near the root sections. Provision of as large a spacing as possible without impairing the aerodynamic efficiency of the compressor is therefore desirable.

Inlet lips, accessory housing, and islands. - Typical inlet-lip, accessory-housing, and island icing (reference 4) is also shown in figure 9. Double-peak ice formations characteristic of glaze ice are shown on the inlet lips and the accessory housing. Large ice formations on the islands cause considerable blocking of the duct area with consequent aerodynamic penalties. All these ice formations may constitute a possible hazard to the engine if they shed into the compressor.

Compressor blading. - By careful scrutiny of figure 9, ice can be distinguished on the roots of the first- and second-stage stator blades. When this figure was taken, the engine was in operation; consequently only the stator blades are shown because the camera used could not "stop" the rotor blades. Stator-blade icing is similar to that of the inlet guide vanes, although not as severe because the scraping action of the rotor blades tends to limit the growth of the ice formations.

Rotor-blade icing has been observed but only at reduced engine speeds. Whenever the rotor blades iced during low-engine-speed operation, and the speed was subsequently increased, the ice formations were removed.

No instance of the icing of centrifugal-flow-type impellers has been reported to date.

## E F F E C T O F I C I N G O N

### T U R B O J E T - E N G I N E P E R F O R M A N C E

As ice formations build up on an unprotected engine installation during an icing condition, the pressure losses are increased and result in a reduced total pressure at the compressor inlet. For an engine operating with a choked exhaust nozzle, the air flow through the engine is reduced and results in a reduction in thrust. For an engine operating with an unchoked exhaust nozzle, the loss in total pressure results in a decrease in mass flow, but is accompanied by an increase in turbine temperature that partly offsets the loss in thrust caused by the reduction in air flow and engine-outlet total pressure. The tail-pipe temperature, however, remains essentially constant and, consequently, dependence on tail-pipe temperature rise as a means of indicating icing is unreliable.

The pressure losses due to icing cause an increase in the specific fuel consumption.

Pressure losses associated with icing. - The pressure losses caused by ice in a direct-ram inlet (similar to that shown in fig. 3) used in reference 7 are shown in figure 10. These losses  $\left(\frac{P_1-P_2}{q_{scr}}\right)_i - \left(\frac{P_1-P_2}{q_{scr}}\right)_u$  were caused by icing of the duct, the accessory housing, the islands, and the screen. (The symbols used in this report are defined in the appendix.) The most rapid losses during the initial part of the icing period were caused by the glaze icing obtained at 20° F on a closely spaced round-wire screen and amounted to 1.20 for a 4-minute icing period. A streamlined-wire screen with double the spacing of the round-wire screen did not appreciably reduce the pressure losses of the configuration. Additional studies of the same inlet configuration without a screen indicated a pressure loss  $\left(\frac{P_1-P_2}{q_1}\right)_i - \left(\frac{P_1-P_2}{q_1}\right)_u$  in the order of 0.18 for a 5-minute icing period at an air temperature of 10° F. The pressure losses shown in figure 10 therefore may be considered primarily caused by screen icing. The pressure loss after 3 minutes of icing may result in a thrust loss as high as 30 percent.

The pressure losses caused by compressor-inlet-screen icing are prohibitive, and therefore retraction of the screen is desirable. If the screen is retracted, the inlet-guide-vane icing constitutes the principal source of pressure loss in an engine installation.

Pressure losses across an inlet-guide-vane cascade in icing conditions are reported in reference 8. The pressure loss  $\left(\frac{P_2-P_3}{q_2}\right)_i$  as a function of icing time is shown in figure 11 for various combinations of icing conditions ahead of the vanes. Prior to icing, vane pressure losses from 0.04 to 0.08 were obtained, whereas after 3 minutes in icing conditions the pressure losses mounted as high as 0.54 or a thrust loss of approximately 15 percent for a large jet engine. The most serious conditions were encountered at an inlet-air total temperature of 22° F and a water content of 0.9 gram per cubic meter. The severe losses at this temperature resulted from the characteristic glaze-ice formation shown in figure 12(a). Heavy ice formations accreted both on the vane leading edges and on the trailing-edge portion of the concave surfaces. Typical rime icing at an air temperature of 0° F is shown in figure 12(b). The pressure losses resulting from this type of ice formation (air total temperature, 0° F) were considerably less than from glaze icing (air total temperature, 22° F), as shown in figure 11.

Effect of icing on axial-flow-type turbojet-engine performance. - The results of studies of icing effects on axial-flow-type engine

performance are shown in figures 13 to 15. In natural flight icing conditions (fig. 13) with an axial-flow-type engine operating at 92 percent of rated engine speed, the engine thrust loss was 26 percent with an attendant 160° F tail-pipe-temperature rise after an effective duration of approximately 30 minutes in icing (reference 4). During the time shown by the dotted portion of the curve, the icing was too intermittent and light for reliable measurements and the engine was stopped to conserve fuel. A photograph of the engine ice formations that caused the 26-percent loss in thrust is shown in figure 14. The compressor inlet is considerably blocked by large ice formations shed from the islands. In addition, ice can be plainly seen on the inlet guide vanes. The increase in thrust near the end of the run was caused by the breakup and subsequent passing through the engine of some of the large ice formations on the islands. Data presented in reference 4 indicate that the initial rate of thrust loss may be as high as 14 percent within  $3\frac{1}{2}$  minutes of encountering an icing condition of moderate severity. After an initial rapid thrust loss, the rate at which the thrust is decreased may be reduced if the ice formations become dislodged or break off.

The effect of pressure losses in an icing condition on specific fuel consumption and thrust is shown in figure 15 as a function of engine-air-flow reduction (reference 5). The data indicate that the percentage thrust loss and the percentage increase in specific fuel consumption as functions of air flow are substantially independent of engine speed and altitude. Figure 15 indicates that for an air-flow reduction of 18 percent, the thrust was decreased by 20 percent and the specific fuel consumption was increased by 31 percent. The turbojet engine used in reference 5 was rendered inoperative when the air flow was reduced by 28 percent.

Effect of icing on centrifugal-flow-type turbojet-engine performance. - Representative performance values of the changes in tail-pipe temperature, thrust, and specific fuel consumption for a centrifugal-flow-type turbojet engine (unpublished data) are shown in figure 16 as a function of time in an icing condition. At the end of the investigation, the tail-pipe temperature had increased 90° F and the thrust was reduced 10 percent. The specific fuel consumption was also increased by about 9 percent. For these performance changes, the front-entry screen was about 60 percent blocked with ice (fig. 8(b)). Because the rear-entry inlet-air temperature was 33° F, no ice formed on the rear screen. More serious performance losses can be expected at a lower inlet-air temperature, when both screens are subject to icing.

Damage caused by ice. - Shedding of large ice formations from components ahead of the compressor inlet when no compressor-inlet screen is used may cause engine blow-out and structural damage. An indication of the quantity of ice that may be shed from the inlet and the engine components and subsequently swallowed by the compressor is shown in figure 17 (reference 4). A photograph of the ice formations 1 minute before shedding occurred is shown in figure 17(a); figure 17(b) was taken 1 minute after the shedding of the ice formations. This sudden intake of ice caused a momentary drop of about 1000 rpm in engine speed. Inspection after shutdown showed no damage to the engine.

Ice shedding from inlet lips, accessory housing, and islands generally shatters into small pieces and passes harmlessly through the engine. Damage may occur if a large piece of ice lodges in the space between a rotor- and stator-blade stage or if a large piece strikes a rotor blade and deflects it into the guide vanes or stator blades. Wider inlet-guide-vane spacing permits passage of large ice pieces into the compressor and thereby increases the possibility of damage to the engine.

Freezing of water in the compressor during outside parking or storage of an aircraft may result in damage if an attempt is made to start the engine before de-icing the compressor blading.

No damage resulting from icing of centrifugal-flow-type turbojet engines has been reported to date.

## I C I N G - P R O T E C T I O N M E T H O D S

Three basic methods of protecting a turbojet engine against icing have been evaluated and are summarized in the following sections. The methods are (1) heating of surfaces subject to icing, (2) heating of the inlet air stream by the injection of hot gases into the inlet air, and (3) inertia separation of water droplets from the inlet air.

### SURFACE HEATING

#### General Considerations

The protection of turbojet-engine installations by local heating of the surfaces subject to icing is similar to the problem of airfoil ice protection. Icing protection may be accomplished by continuous heating of the surfaces to a temperature sufficient to prevent ice, or by cyclical de-icing in which ice is permitted to form on the surfaces and then removed periodically by a short intense application of heat.

In continuous heating, the surfaces are either raised to a temperature just sufficient to maintain the impinging water in a liquid state over the entire wetted surface, or are supplied sufficient heat to evaporate the impinging water in a specified distance behind the impingement area while the remaining surface is unheated. The highest local heating rates are required if the water is to be completely evaporated. The minimum total heat requirement for complete icing protection may be obtained either by evaporation of all the impinged water or by maintaining the water in a liquid state, depending on the extent of impingement. For example, the minimum heat requirement for an accessory housing may be obtained by evaporation of all the impinged water in a region near the nose, whereas for inlet guide vanes, subject to impingement over the greater portion of the surface, the minimum heat requirement is obtained by maintaining the entire surface at 32° F.

In cyclical de-icing, a water film between the component surface and the ice, caused by heat application, permits removal of the ice by aerodynamic forces. Only a few components are heated during the relatively short, intense heating periods, the rest being allowed to ice. Because the components are heated successively, proper grouping of the components permits the shifting of heat from one group to another and thereby maintains a constant heat load. The total heat input for cyclical de-icing is greatly reduced from that required for continuous heating. The icing time for the components is limited by the amount of ice that can be tolerated without seriously affecting engine performance and that does not damage the engine.

Calculations of the anti-icing heat requirement for icing protection of inlet components are difficult because the solutions are involved and are affected greatly by the assumptions that must be made where an adequate theory and experimental data are lacking. The general method of determining the heat requirements for surfaces subject to icing is discussed in detail in references 9 and 10.

The principal factors that affect the heat requirements for anti-icing are surface and air temperatures, air velocity, water-interception rate, pressure altitude, and geometric shape of the body. The local heat requirements increase with increasing surface temperature, air velocity, and water interception; decrease with increasing air temperature; and are little affected by changes in pressure altitude. More detailed information pertaining to heat-transfer coefficients and droplet impingement may be found in the references given in the following table:

Subject	References
Dry-air convective heat-transfer coefficient	
Bodies of revolution	11, 12
Airfoils	13, 14, 15, 16, 17
Cylinders and flat plates	13, 14, 15, 16
Spheres	18
Pipe flow and tube entrances	16, 19, 20, 21
Droplet impingement	
Airfoils	22, 23, 24
Cylinders, ribbons, and spheres	25

By resolving a component into fundamental shapes of proper sizes, an approximate theoretical solution may be effected. The accessory housing, for example, may be treated as a sphere followed by a body of revolution. Furthermore, other approximations and assumptions must be made depending on the specific conditions involved: namely, the type of boundary-layer flow and the location of transition, the wetness of the surface, and the limit of droplet impingement. These problems are discussed sufficiently in the references cited to permit an approximation of anti-icing heat requirements for most surfaces with a known velocity distribution.

For many surfaces, especially small components, the necessary heat is often very difficult to supply to the leading and trailing edges because of structural factors. In most installations a considerable amount of heat is wasted because of the practical inability to obtain the theoretically required surface temperature for an optimum heat distribution. The heating requirements for an installation therefore depend on the means by which the heat is distributed.

The practical difficulties and high heating densities involved in heating the compressor-inlet screen are quite formidable; therefore for all-weather aircraft the screens should either be removed or made retractable. In the absence of screens, the inlet guide vanes become the critical components in regard to icing. The remaining inlet components subject to icing are the islands and island fairings, the accessory housing, the inlet ducting, and the inlet lips. These components can generally withstand long periods of exposure to icing without prohibitive aerodynamic losses; these components, however, should be protected for all-weather aircraft.

Experimental NACA investigations of turbojet-engine surface heating to date have been confined to the inlet guide vanes with the anti-icing heat requirements evaluated for three types of heating: gas-heating with hollow vanes, electrical heating by resistance elements, and heating by eddy-current generation. These investigations will be discussed in subsequent sections.

### Heating Requirements for Inlet Guide Vanes

The heating requirements for icing protection of inlet guide vanes by hot gas and electrical means are reported in references 8 and 26, respectively. The investigations were made with a two-dimensional vane cascade in a short rectangular duct mounted in the icing research tunnel (fig. 18). Although all the vanes were heated, only the center vane was instrumented to obtain heat-transfer data. The vanes were of approximately 6-inch span,  $2\frac{3}{8}$ -inch chord, and 3-inch spacing. Thermocouples used to obtain chordwise temperature distributions on the vane surface were located at the midspan position.

Gas heating of vanes. - For the studies in reference 8, the center vane was heated by passing hot gas through internal passages. Three vane models were investigated, differing only in internal gas-passage construction. Cross sections of the three vanes, hereinafter designated vanes 1, 2, and 3, and the location of surface-temperature instrumentation are shown in figure 19.

Investigations of gas-heated airfoil shapes (references 10 and 17) showed that large quantities of heat were wasted near the center-chord portions of the shapes and that the leading and trailing edges were at the lowest temperature. Furthermore, the icing characteristics of the inlet guide vanes shown in figure 12 indicated that the largest amount of icing occurs in these regions. By the addition of fins and inserts in the internal passages (fig. 19, vanes 2 and 3), the internal heat distribution may be improved and the gas flow may be reduced (reference 17).

A comparison of the local heat-transfer rates through the vanes, as indicated by the surface-temperature rise above the datum temperature, was obtained in dry air for constant values of air velocity ahead of the vanes, gas flow, and gas temperature (fig. 20). The datum temperature is the temperature of an unheated, nonconducting surface immersed in a moving fluid, and is also known as kinetic temperature, adiabatic wall (surface) temperature, surface datum temperature, datum air temperature,



and effective (gas) temperature. In figure 20, the comparison of heat transfer through the three vanes at midspan shows that the two modified vanes transferred considerably more heat than the fully hollow vane, especially at the leading and trailing edges, which are the critical points in guide-vane anti-icing. Vane 2 transferred the most heat at the leading edge, but was inferior to vane 3 at the trailing edge. In addition, vane 2 dissipated excessive heat along the convex surface. Although the optimum vane configuration is not represented by these vanes, the results point the way toward the achievement of an efficient gas-heated vane.

Because heat is transferred from the vane surfaces, the temperature of the hot gas decreases as it passes through the vane. The heat required for icing protection is therefore established by the minimum heat content of the gas at the vane exit. In the studies reported in reference 8, only midspans of the vanes were instrumented to obtain chordwise heat-transfer rates; consequently, in order to determine the minimum heat content for icing protection, ice was permitted to form on the vanes only from the midspan to the vane exit. The data obtained at the midspan can thus be considered to represent the minimum heat requirements at any spanwise station. A comparison of the minimum heat content required for ice protection for the three vanes investigated is shown in figure 21 as a function of datum temperature. The data shown were obtained at two air velocities and constant values of gas flow and liquid-water content. The vanes with fins and inserts required from 40 to 50 percent less heat than the fully hollow vane, with vane 3 requiring less heat than vane 2.

For a given vane-passage configuration, the internal-heat-transfer coefficient is a function of gas flow and gas temperature (reference 17). When gas is bled from a turbojet engine, a minimum quantity of bleed is desirable; consequently, a high gas temperature should be used. The gas-flow requirements, expressed as a percentage of the inlet-air flow, for ice protection of the vanes investigated are shown in figure 22 as a function of the inlet-vane gas temperature. The gas-flow requirements of figure 22 were calculated for a minimum surface temperature of  $32^{\circ}$  F at the trailing edge of the vane-outlet station. At a  $500^{\circ}$  F inlet-gas temperature, the gas-flow requirements were less than half of those at a  $300^{\circ}$  F inlet-gas temperature. The requirements for vane 3 ranged from approximately 40 to 60 percent of those for vane 1.

The effects on engine performance resulting from the bleeding of either compressor or turbine air for gas heating of vanes may be calculated by the method of reference 27. For the small quantities of gas required to anti-ice the guide vanes (approximately 0.5 percent of the engine air flow, fig. 22), the engine thrust loss will be approximately 1 percent in severe icing conditions.

Reduced heat requirements for ice protection with a cyclical method of gas heating should be obtainable for guide vanes of the type investigated. The small internal heating passages produce high heat-transfer coefficients and rapid heating and cooling rates at the exposed surfaces. With short, well-insulated approach ducts the inlet guide vanes should therefore de-ice with short heat-on times.

Continuous electrical heating of vanes. - The use of electrical heating of inlet guide vanes permits an approach to the optimum heat distribution for ice prevention by allowing a close control of the local heat input; consequently only small amounts of heat are wasted.

In the investigation reported in reference 26, the center vane contained Nichrome heating wires with separate circuits for independent chordwise control of the electrical power input as shown in figure 23. Heating elements of the type used could not be located closer to the trailing edge than indicated because of the thinness of the aluminum vane metal. Typical surface-temperature distributions along the vane surfaces with continuous heating are shown in figure 24 for two datum temperatures. The increase in average surface temperature with decreasing datum temperature resulted from the overheating of the vane necessary to maintain the leading and trailing edges at  $32^{\circ}$  F. The overheating of the vane was caused by the inability to locate heating elements beyond the regions shown in figure 23. The trailing edge in particular acted as a fin and constituted a heat sink for the last heating element.

The minimum average power density for ice protection with continuous heating of the vanes is shown in figure 25 as a function of datum temperature. The values of power density shown in this figure were obtained by selectively adjusting the power input to the four heating elements for a given icing condition until the minimum power for ice prevention was obtained. For a current engine with 28 vanes of the type investigated, icing protection at an ambient-air temperature of  $-11^{\circ}$  F and a compressor-inlet velocity of 400 feet per second could be obtained with a total power input of 7.8 kilowatts. Analysis of the experimental data indicates that the power requirements shown in figure 25 could be reduced approximately 25 percent if a uniform surface temperature of  $32^{\circ}$  F could be obtained with a suitable heater arrangement. Estimates of the heating requirements for vanes and icing conditions other than those investigated may be made by proper use of the wet-air method of analysis, as presented in reference 26.

The effects on engine performance resulting from shaft-power extraction from an engine for electrical heating of inlet guide vanes are negligible and may be calculated by the method of reference 28; however, the weight penalty of the generating equipment is appreciable.

Cyclical electric de-icing of vanes. - The power requirements for ice protection of inlet guide vanes and consequently the weight of the generating equipment can be reduced by cyclical de-icing. The total energy or power required to achieve cyclical de-icing can be shown to decrease with shorter heating periods; that is, short intervals of high-power application are more economical than longer intervals with a low-power application. The establishment of a heating cycle depends also on the rate of ice accretion and the resulting pressure losses. A long icing (heat-off) period is most desirable; however, it can be seen from figure 11 that large losses occurred at the higher air temperature and water content and for icing periods greater than 1 minute. It therefore appears that relatively short heat-off periods in the order of 60 seconds are required for cyclical de-icing of vanes.

With a cyclical de-icing system, the vane surface temperature is raised to approximately  $32^{\circ}$  F during the heat-on period. As stated previously, the lowest total-power requirements are attained with a high instantaneous power input, which results in a maximum temperature-rise rate. Typical vane-surface-temperature variations with time for heat-on periods of 10, 20, and 30 seconds are shown in figure 26 for the leading and trailing edges. Ice was shed at the end of each heat-on period or when the surface temperature reached  $32^{\circ}$  F. For the 30-second heat-on period, the trailing edge was somewhat overheated and ice removal occurred after only 12 seconds (fig. 26).

The variation of the average instantaneous power density required for vane cyclical de-icing is shown in figure 27 as a function of the datum temperature for 10-, 20-, and 30-second heat-on periods, and heat-off periods of 60 to 120 seconds. The average instantaneous power density was higher for the 10-second heat-on period than for both of the other two periods, for which the power densities are approximately the same. Because for a given area the total energy can be expressed in terms of the product of the average instantaneous power density and the heat-on time, the total energy was least for the 10-second heat-on period. Limited data indicate that air speed did not greatly affect the power required for ice removal as shown by the 10-second data points for 240 and 390 feet per second (fig. 27). Negligible differences in power requirements were observed for an increase in the heat-off period from 60 to 120 seconds for the same heat-on periods.

The results of reference 26 indicate that with cyclical de-icing of inlet guide vanes total-power input savings as high as 79 percent for a current engine may be achieved as compared with continuous heating; consequently, large generator-weight savings can be realized. The shedding of such ice as may build up on the vanes during the heat-off period of 60 seconds is not believed to be a hazard to the compressors of current engines.

Eddy-current heating of vanes. - Another system utilizing electrical power for ice prevention on inlet guide vanes (reference 29) is the use of eddy currents to heat axial-flow inlet guide vanes and compressor blades. The principle of eddy-current heating requires a ferromagnetic flux path and a means of rapidly varying the flux in the elements to be heated. The application of this principle to inlet guide vanes is illustrated by the schematic diagram in figure 28. The magnetic flux is supplied by the stationary direct-current coil from which the flux travels in a ferromagnetic circuit consisting of the islands, shell, inlet guide vanes, and a chopping mechanism in the rotor. The chopper (fig. 28) provides a varying air gap that causes a flux change and results in the creation of eddy currents and heat. The teeth in the chopper should be of such a length that as one blade is leaving a tooth another blade is taking its place in the magnetic circuit. In this manner, the only parts of the magnetic circuit that are experiencing a flux change are the blading and the immediately adjacent parts. A constant flux is thus maintained in the rest of the magnetic circuit and a constant flux always links the coil. An alternating current may be used in place of the flux-chopping mechanism; however, this system would heat all parts through which the current passes.

In a general application of eddy-current heating where more than one set of blades is protected, the chopper may be either in the rotor or the stator but the blades to be heated must pass over the teeth of the chopper. A chopper must therefore be provided for each row of blades to be protected.

The electrical power required for magnetization of the direct-current coil is in the order of 0.002 percent of the turbine power output. In addition, the shaft power extracted for the generation of eddy currents to produce the heat required for ice protection of the guide vanes is small and for the proposed design in reference 29 is 0.2 percent of the turbine power output. The total load would cause a thrust loss in the order of 0.5 percent. Difficulties that may be expected through the use of an eddy-current heating system includes weight increases necessitated by the use of ferrous blading, coils, and chopping mechanisms. In addition, the complexity of the electrical equipment required necessitates considerable design change in the construction of the rotor and the housing of turbojet engines.

#### HOT-GAS-BLEEDBACK SYSTEM

Another approach to the problem of turbojet-engine-inlet icing protection is the heating of all the inlet air and the entrained water

to a temperature above freezing. Initial studies indicated that sufficient amounts of gas can be bled from the engine to raise the inlet-air temperature above freezing and still permit engine operation, but with a reduction in thrust. The gas must be added to the inlet air in a manner that provides good heat distribution at the components to be protected. The greatest economy in the use of the heat provided by the bleedback gas is realized when the temperature of the inlet air after heating is uniform throughout the air stream.

Because the operational time in icing for any engine is small compared with its total life, the engine should not be penalized by the de-icing system during normal operation. A system of heat addition that has no inlet pressure losses during normal operation is therefore required. The use of high-velocity heated-air jets directed normal to the inlet air stream was investigated (reference 30) as a means of obtaining good heat distribution with no resultant penalties during normal operation. These studies showed that adequate penetration and good mixing could be obtained at high jet total pressures.

Concurrently, an exploratory investigation using an axial-flow turbojet engine was made in the NACA Lewis altitude wind tunnel to determine the over-all practicability of the hot-gas-bleedback system (reference 5). The results of this investigation showed that the system was not only practical but that it could be used with minor modifications to the engine and the nacelle. It was found that the size and the location of the orifices for injecting the hot gases were of primary importance. Good icing protection could be obtained only if the orifices were large enough to provide adequate penetration and if a sufficient number of orifices was provided for good temperature distribution at the engine inlet.

In order to provide a rational basis for determining the size and the location of the injection orifices, a systematic study was undertaken with three types of representative turbojet-engine inlet. The inlets investigated were two-thirds full scale and comprised an offset inlet (reference 31), a long straight inlet (reference 32), and a short straight inlet (reference 33). The models investigated were designed for a maximum mass flow of 32 pounds per second, corresponding to the rated flow through a full-scale axial-flow-type engine of 4000-pound static thrust at sea level.

The instrumentation used in the long-straight-inlet investigation (reference 32) is shown in figure 29 and is typical of that used in the other inlet investigations. Measurements were made of the mass flow, ram-pressure recovery, temperature distribution at the simulated engine inlet, and pressure drop across the screen. The surface temperature in

the inlet duct and on the accessory housing was measured as well as nacelle-lip pressure and temperature distribution. A 1/4-inch-mesh, 0.050-inch-diameter wire screen was mounted in the models to simulate a protective compressor-inlet screen and to provide a means of indicating icing.

As a result of these investigations, a design procedure has been evolved from which the heat requirements can be determined and a satisfactory orifice configuration obtained (reference 32).

Heating requirements. - The results of references 31 to 33 show that the heat requirements for adequate icing protection are based on raising the total temperature of the inlet air and the entrained water to a temperature sufficiently high that the minimum surface temperature on the engine components is maintained above the freezing level. Generally, the lowest surface temperature is obtained at the point of highest velocity. Consideration must, however, be given to temperature distribution in the inlet air after mixing in order to determine the critical icing region.

A study of the temperature distributions at the simulated engine inlets of references 31 and 32 (long inlets) showed that for a well-designed orifice configuration the ratio of the minimum temperature rise to the average temperature rise was approximately 0.8. This ratio is defined as the mixing efficiency. For the short, straight inlet of reference 33, the best design gave a mixing efficiency of approximately 0.75 because the shorter duct length did not permit as good mixing.

Calculation of bleedback as function of gas temperature. - In the determination of the bleedback quantity, temperature rise required for protection must be estimated. This estimation may be made by determining the loss in temperature recovery  $\Delta t$  at the surface for the point of maximum velocity in the duct. The loss in temperature recovery is then added to the difference between the stream total temperature and the freezing level ( $32^{\circ}$  F). In order to allow for imperfect mixing, this value is then divided by the mixing efficiency, which results in an over-all temperature rise  $\Delta T$ . This value is then utilized in the following approximate heat-balance equation:

$$c_{p,g} W_g [T_g - (T_0 + \Delta T)] = c_p (W_a - W_g)(\Delta T) + mL (W_a - W_g) + c_{p,w} (W_s + m)(\Delta T)(W_a - W_g) \quad (1)$$

from which the bleedback may be expressed as

$$\beta = \frac{W_g}{W_a} = \frac{c_p (\Delta T) + mL + c_{p,w} (W_s + m)(\Delta T)}{c_{p,g} [T_g - (T_0 + \Delta T)] + c_p (\Delta T) + mL + c_{p,w} (W_s + m)(\Delta T)} \quad (2)$$

In order to compare the results calculated by this method with the experimental results given in reference 32, two curves of bleedback as a function of injection gas temperature have been calculated for the maximum and minimum conditions investigated. These curves are shown in figure 30 together with the experimental data. These data represent a condition of marginal icing as defined in reference 31. Agreement between the calculated and experimental values is satisfactory.

Orifice configuration and temperature distribution. - The method of determining a satisfactory orifice configuration is given in reference 32. The method should be modified to utilize the orifice-flow-coefficient data given in reference 34 and the more comprehensive jet-penetration data given in reference 35. In general, the following procedure is used to determine an orifice configuration:

The actual weight flow through the engine at a temperature corresponding to the total temperature required for icing protection is first determined. The required hot-gas flow is then the product of the bleedback (see equation (2)) and the actual weight flow. The total jet area required for passage of the hot gas at the temperature and the pressure available may then be calculated if the flow coefficient is known. An average value of the coefficient must be estimated from the results of reference 34 because the individual jet diameters are as yet unknown. After the required jet area is determined, the trial orifice configurations can be laid out by using the penetration curves of reference 35 and the method of reference 32.

The orifice configuration designed for the long straight inlet (reference 32), shown in figure 31, resulted in a satisfactory temperature distribution at the design value of bleedback. The analysis and results of reference 32 show that the temperature distribution obtained at the design bleedback value was independent of gas temperature and weight flow through the engine. Operation at bleedback other than the design value resulted in poor temperature distributions at the simulated engine inlet (see fig. 8, reference 32). The results of references 31 to 33 show that the temperature distribution was almost unaffected by angles of attack as high as 8°.

Pressure losses associated with bleedback system. - The pressure loss associated with bleedback is caused by the addition of both heat and mass to the inlet air stream. Because the jets were directed perpendicularly to the air stream, no additive momentum component to the

main flow was contributed that added to the pressure recovery. The loss in total pressure caused by mass and heat addition can be easily calculated provided that a constant-area duct is assumed. The following equation may be used if compressibility effects are negligible:

$$P_1 - P_2 = q_1 \left[ \left( \frac{1}{1-\beta} \right)^2 \frac{T_2}{T_1} - 1 \right] \quad (3)$$

A comparison of the pressure recoveries calculated by equation (3) with the experimental data of reference 32 is shown in figure 32, wherein the pressure recovery is plotted as a function of the bleedback for an injection gas temperature of 1000° F. The maximum pressure recovery obtainable with no bleedback was 0.95. The theoretical values were corrected to the maximum ram-pressure recovery with no bleedback. The calculated curve is in good agreement with the experimental data although lying slightly below it. This deviation was caused, in part, by the divergence of the duct aft of the jet location and a consequent reduction in the air-stream dynamic pressure that results in decreased pressure losses.

Effect of bleedback on engine performance. - The engine-inlet total pressure and total temperature and the bleedback can be calculated by the methods previously given. These values can then be used to determine the engine performance from the charts of reference 27. The best temperature distribution and consequently the best icing protection are obtained at the design bleedback value. Economical engine operation requires that the engine inlet-air temperature be held nearly constant and at a value slightly above the freezing level, which can be accomplished only by controlling the temperature of the injection gas. A possible means of control is by mixing turbine-inlet and compressor-outlet air. Another method would be to heat the compressor-outlet air by passing it through a combustor or heat exchanger.

The effect on engine thrust of operation at the design bleedback value and at an engine-inlet-air temperature slightly above freezing is shown in figure 33 as a function of air-stream static temperature. These data were calculated by the method of reference 27 for an engine operating at rated engine speed and turbine-inlet temperature. The assumed sea-level rated engine characteristics were a thrust of 4000 pounds and an engine air flow of 70 pounds per second. The nacelle area at the section where the hot gases were introduced was assumed as 2.045 square feet and the mixing efficiency as 0.8. The thrust loss is seen to decrease linearly with increasing air-stream static temperature and icing protection at 0° F to result in a thrust loss of 15 percent.



The foregoing discussion indicates that the hot-gas bleedback system can provide adequate icing protection under severe icing conditions with moderate engine-performance penalties that can be readily predicted.

## INERTIA-SEPARATION INLETS

### Alternate-Duct System

A system has been developed by which cloud water droplets are separated out of the air stream by utilizing the inertia difference between the air and the cloud water droplets to deviate the droplets from the air streamlines. Because of the small inertia of cloud water droplets, sharp air-stream curvatures and high air velocities are required to separate these droplets. As a consequence, large duct pressure losses are encountered if the smallest droplets are to be separated. Inasmuch as large duct losses cannot be tolerated for satisfactory turbojet-engine operation, some fraction of the smaller cloud droplets in the range of 5 to 20 microns in diameter cannot be eliminated by a practical inlet; consequently, air with a reduced number of droplets is passed into the compressor. The water separated out of the air stream is allowed to collect harmlessly in specific sections of the inlet. The ice protection afforded an engine is therefore a compromise between the pressure losses inherent in an inertia-separation inlet and those resulting from icing caused by the unseparated water.

An inlet designed to eliminate a large percentage of the water droplets from the air by momentum separation (references 7 and 36) is shown in figure 34 and consists of a single-inlet nacelle, a main duct with compressor-inlet screen, and an alternate duct with sharply curved passages. When an icing condition is encountered, the screen in the main duct becomes rapidly blocked with ice and the air stream then shifts to the alternate duct. The droplets that deviate out of the air stream at the entrance to the alternate duct impinge harmlessly in the "trap" formed by the ice-blocked main-duct screen, the accessory housing, and the duct-splitter ring. In an iced condition, the main-duct screen forms a wall of the alternate duct from the duct-splitter ring to the compressor inlet.

The aerodynamic and water-separation results obtained with several inertia-separation inlets are summarized as follows:

- (1) Large pressure losses in the main duct were caused by the presence of the alternate duct opening for conditions of high air velocities in the duct (reference 7). These losses could be minimized

and made to approach conventional direct-ram inlet losses by designing the inlet to operate at relatively low air velocities. Effects of a change in angle of attack on the aerodynamic characteristics of the inlets were negligible.

(2) All the inlets investigated in references 7 and 36 were unsatisfactory with respect to the quantity of mass flow that could be passed through the alternate duct. It is estimated that for current engines a nacelle 10 to 15 percent larger in diameter must be used for an inertia-separation inlet than for a comparable direct-ram inlet. This requirement is necessary to insure an alternate duct of sufficient size to pass the required mass flow while providing a high degree of water separation by utilizing a small alternate-duct inlet opening. It is apparent from reference 7 that, had mass-flow values representative of current engines been obtained, the thrust losses caused by pressure losses would have been prohibitive.

(3) The degree of water separation was a function of the alternate-duct-inlet gap, radial offset of the duct-splitter ring with respect to the inlet, curvature of the duct passages, and duct-air velocities (references 7 and 36). The greater the radial offset and the smaller the inlet gap, the higher is the degree of water separation. The pressure losses and the mass flow through the duct, however, must also be considered, and it is these factors that will principally influence a compromise design between aerodynamic performance and good water separation.

(4) The decrease in mass flow and the increased pressure losses with time for inertia-separation inlets in icing conditions presented in reference 7 were caused principally by severe ice formations in the alternate-duct elbow. Consequently, these surfaces must be protected in order to permit continued engine operation for long icing encounters. Ice formations on other components will in time cause reductions in mass flow and pressure in the inlet. All major components must therefore be protected to insure safe operation of an engine in icing conditions.

#### Submerged-Inlet System

An investigation (reference 37) was made to determine the degree of water separation that can be accomplished by use of annular submerged inlets (fig. 35). The results of the investigation indicate that these inlets were partly successful in separating water droplets from the air stream. Unless extremely high inlet-velocity ratios and small inlet gaps were used, the inlets admitted moderate quantities of water. The

use of such small gaps and high velocities restricts the mass flow through the inlet and causes large pressure losses.

Other investigations of submerged-type inlets used in conjunction with fuel-cell vents are reported in reference 38. A typical vent installation using a submerged-type inlet mounted in the underside of a wing is shown in figure 36(a). Icing was observed on all surfaces of the inlet, namely, the ramp, the diverging sidewalls, and the inlet lip as shown in figure 36(b), and also on the wing surface ahead of the inlet. Although the air flow through the inlet (vent tubes) was quite low, the pressure losses associated with these ice formations (especially those on the surface ahead of the inlet) were found to be very high. Severe aerodynamic penalties can consequently be anticipated for engine installations requiring large quantities of air flow. Icing protection is therefore required for submerged-inlet components.

## S U M M A R Y O F R E S U L T S

From wind-tunnel investigations of several methods of ice protection for turbojet-engine components, the following results are cited:

### Surface Heating

1. Economical surface heating was accomplished by the use of hot gas or electrical means.

2. The use of fins and inserts in the internal passages of gas-heated guide vanes decreased the gas flow required for icing protection by as much as 50 percent. Icing protection for inlet guide vanes with internal inserts was achieved with approximately 0.5 percent of the engine air flow and an attendant (calculated) thrust loss of approximately 1 percent. Fins and inserts will also decrease the gas-flow requirements for the remaining engine components.

3. Icing protection for vanes by the use of continuous electrical heating was shown to be feasible. For an engine assumed to have 28 vanes of the type investigated, icing protection at an ambient-air temperature of  $-11^{\circ}$  F and a compressor-inlet air velocity of 400 feet per second was obtained with 7.8 kilowatts (average heating intensity of 9 watts/sq in.).

4. The use of cyclical de-icing of vanes permitted a reduction in the total electrical power of 79 percent as compared with continuous

heating. Cycle periods in the order of 10 seconds heat-on and 60 seconds heat-off appeared to give the best over-all performance. Cyclical de-icing of the other engine components (whenever possible) reduces the total electric-power load and consequently generating-equipment weight.

5. Although icing protection of inlet guide vanes and compressor blading appeared possible by eddy-current generation, considerable structural change is necessary to incorporate the system into turbojet engines.

#### Hot-Gas Bleedback

1. A method for obtaining a satisfactory orifice configuration for hot-gas-bleedback icing protection was developed and resulted in good temperature distribution in the inlet air stream.

2. The heat requirements and the pressure and mass-flow losses were shown to be readily calculable from theoretical relations.

3. The loss in thrust resulting from bleedback amounted to approximately 15 percent for icing protection at an air-stream static temperature of  $0^{\circ}$  F.

#### Inertia-Separation Inlets

1. Complete icing protection without prohibitive air-flow and pressure losses could not be achieved. The requirement for extensive local heating and the aerodynamic penalties associated with the ducts limited the use of inertia-separation inlets for turbojet engines.

2. Submerged inlets required local heating of the inlet ramp, side walls, and inlet lip, as well as removal of all ice ahead of the inlet.

#### C O N C L U D I N G R E M A R K S

#### A N D R E C O M M E N D A T I O N S

The need for icing protection of a turbojet engine results from the mass-flow and pressure losses associated with the icing of the various engine components. The compressor-inlet screen, in particular, constitutes a hazard that can cause engine failure in a matter of minutes. The inlet guide vanes of an axial-flow-type turbojet engine also

represent a distinct hazard that could cause engine shutdown in a short period of time. The removal or retraction of the inlet screen is recommended to increase the engine icing tolerance and permit easier icing protection. In addition, an increase in the size and the spacing of the inlet guide vanes would be desirable. The rest of the engine components such as the inlet lips, the duct surfaces, the islands, and the accessory housing may require icing protection. The performance losses associated with icing of these components do not constitute an immediate danger to engine operation. The loss in performance caused by these ice formations may, however, result in a considerable decrease in the range and the speed of the aircraft. A centrifugal-flow-type turbojet engine is relatively unsusceptible to icing once the compressor screen has been removed.

Surface heating with hot gas involves the fabrication of ducts and passages beneath the surfaces to be heated. High-temperature materials and insulation add fabrication problems and small weight penalties. With either compressor-outlet or turbine-inlet bleedoff, heating of critical elements, such as guide vanes, can usually be accomplished with sufficient pressure and temperature remaining at the vane outlets to supply protection for some of the secondary elements, such as accessory housings and inlet ducts. During let-down conditions, the available gas pressure and temperature may be marginal for protection of the engine in severe icing conditions.

Difficulties encountered in the fabrication of electrical heating elements and the maintenance problems of an electrical heating system appear to be greater than for a hot-gas system.

The hot-gas-bleedback system (for heating inlet air) can be applied to current engines with minor modifications to the engine installation. The high temperatures and pressures required may be obtained by the bleedback of turbine-inlet gas or by compressor-outlet air with reheat. A hot-gas-bleedback system that employs combustion gases will pollute the inlet air and affect the use of the compressor air for cabin pressurization purposes.

Icing protection may be obtained by any of the previously described systems. All the systems penalize the aircraft in icing conditions, either by performance losses caused by weight increases, or by thrust losses and increased specific fuel consumption; in nonicing conditions, however, the performance losses are negligible. Surface heating, by either electrical means or hot gas, appears to be the most acceptable in relation to performance losses in icing conditions. The choice of

any particular system is dependent on the supply of heated gas and electrical power available and on the allowable performance and weight penalties.

Lewis Flight Propulsion Laboratory,  
National Advisory Committee for Aeronautics,  
Cleveland, Ohio.

## A P P E N D I X - S Y M B O L S

The following symbols are used in this report:

$c_p$	specific heat of air, Btu/(lb)(°F)
$c_{p,g}$	specific heat of gas, Btu/(lb)(°F)
$c_{p,w}$	specific heat of water, Btu/(lb)(°F)
$L$	latent heat of vaporization of water, Btu/lb
$m$	liquid-water content, lb water/lb air
$P$	total pressure, lb/sq ft absolute
$q$	dynamic pressure, lb/sq ft absolute
$T$	total temperature, °R
$T_g$	plenum-chamber gas temperature, °F
$T_0$	free-stream total temperature, °F
$\Delta T$	temperature difference, $\frac{32-(T_0-\Delta t)}{\text{mixing efficiency}}$ , °F
$\Delta t$	loss in temperature recovery, $12.5 \times 10^{-6} V^2$ , °F
$t_a$	datum temperature, °F
$t_{g,m}$	mean gas temperature in vane, °F
$V$	maximum velocity in duct, ft/sec
$W_a$	mass flow through engine, lb/sec
$W_g$	hot-gas flow through orifices, lb/sec
$W_s$	saturated vapor content, lb water/lb dry air
$w_g$	hot gas flow through vanes, lb/hr
$\beta$	bleedback ratio, $\frac{W_g}{W_a}$

## Subscripts:

- i        iced
- scr     station ahead of compressor-inlet screen
- u        uniced
- 0        free stream
- 1        station in inlet
- 2        station at compressor inlet (ahead of guide vanes)
- 3        station just behind inlet guide vanes

## REFERENCES

1. Sanders, Newell D., and Behun, Michael: Generalization of Turbojet-Engine Performance in Terms of Pumping Characteristics. NACA TN 1927, 1949.
2. Acker, Loren W.: Preliminary Results of Natural Icing of an Axial-Flow Turbojet Engine. NACA RM E8C18, 1948.
3. Acker, Loren W.: Natural Icing of an Axial-Flow Turbojet Engine in Flight for a Single Icing Condition. NACA RM E8F01a, 1948.
4. Acker, Loren W., and Kleinknecht, Kenneth S.: Effects of Inlet Icing on Performance of Axial-Flow Turbojet Engine in Natural Icing Conditions. NACA RM E50C15, 1950.
5. Fleming, William A., and Saari, Martin J.: Inlet Icing and Effectiveness of Hot-Gas Bleedback for Ice Protection of Turbojet Engine. NACA RM E8J25c, 1948.
6. Jones, Alun R., and Lewis, William: Recommended Values of Meteorological Factors to be Considered in the Design of Aircraft Ice-Prevention Equipment. NACA TN 1855, 1949.
7. von Glahn, Uwe, and Blatz, Robert E.: Investigation of Aerodynamic and Icing Characteristics of Water-Inertia-Separation Inlets for Turbojet Engines. NACA RM E50E03, 1950.
8. Gray, Vernon H., and Bowden, Dean T.: Icing Characteristics and Anti-Icing Heat Requirements for Hollow and Internally Modified Gas-Heated Inlet Guide Vanes. NACA RM E50I08, 1950.



9. Neel, Carr B., Jr., Bergrun, Norman R., Jukoff, David, and Schlaff, Bernard A.: The Calculation of the Heat Required for Wing Thermal Ice Prevention in Specified Icing Conditions. NACA TN 1472, 1947.
10. Gray, V. H., and Campbell, R. G.: A Method for Estimating Heat Requirements for Ice Prevention on Gas-Heated Hollow Propeller Blades. NACA TN 1494, 1947.
11. Frick, Charles W., Jr., and McCullough, George B.: A Method for Determining the Rate of Heat Transfer from a Wing or Streamline Body. NACA Rep. 830, 1945. (Formerly NACA ACR, Dec. 1942.)
12. Scherrer, Richard: The Effects of Aerodynamic Heating and Heat Transfer on the Surface Temperature of a Body of Revolution in Steady Supersonic Flight. NACA Rep. 917, 1948. (Formerly NACA TN 1300.)
13. Boelter, L. M. K., Grossman, L. M., Martinelli, R. C., and Morrin, E. H.: An Investigation of Aircraft Heaters. XXIX - Comparison of Several Methods of Calculating Heat Losses from Airfoils. NACA TN 1453, 1948.
14. Johnson, H. A., and Rubesin, M. W.: Aerodynamic Heating and Convective Heat Transfer - Summary of Literature Survey. Trans. ASME, vol. 71, no. 5, July 1949, pp. 447-456.
15. Brown, W. Byron, and Donoughe, Patrick L.: Extension of Boundary-Layer Heat-Transfer Theory to Cooled Turbine Blades. NACA RM E50F02, 1950.
16. Jakob, Max: Heat Transfer. Vol. I. John Wiley & Sons, Inc., 1949.
17. Gray, Vernon H.: Improvements in Heat Transfer for Anti-Icing of Gas-Heated Airfoils with Internal Fins and Partitions. NACA TN 2126, 1950.
18. Loiziansky, L., and Schwab, V.: The Thermal Scale of Turbulence. Rep. No. 239, CAHI, 1935. (In Russian.)
19. Drexel, Roger E., and McAdams, William H.: Heat-Transfer Coefficients for Air Flowing in Round Tubes, in Rectangular Ducts, and around Circular Cylinders. NACA ARR 4F28, 1945.
20. Boelter, L. M. K., Young, G., and Iversen, H. W.: An Investigation of Aircraft Heaters. XXVII - Distribution of Heat-Transfer Rate in the Entrance Section of a Circular Tube. NACA TN 1451, 1948.

21. Lowdermilk, Warren H., and Grele, Milton D.: Influence of Tube-Entrance Configuration on Average Heat-Transfer Coefficients and Friction Factors for Air Flowing in an Inconel Tube. NACA RM E50E23, 1950.
22. Bergrun, Norman R.: A Method for Numerically Calculating the Area and Distribution of Water Impingement on the Leading Edge of an Airfoil in a Cloud. NACA TN 1397, 1947:
23. Guibert, A. G., Janssen, E., and Robbins, W. M.: Determination of Rate, Area, and Distribution of Impingement of Waterdrops on Various Airfoils from Trajectories Obtained on the Differential Analyzer. NACA RM E9A05, 1949.
24. Stickley, A. R.: Some Remarks on the Physical Aspects of the Aircraft Icing Problem. Jour. Aero. Sci., vol. 5, no. 11, Sept. 1938, pp. 442-446.
25. Langmuir, Irving, and Blodgett, Katherine B.: A Mathematical Investigation of Water Droplet Trajectories. Tech. Rep. No. 5418, Air Materiel Command, AAF, Feb. 19, 1946. (Contract No. W-33-038-ac-9151 with Gen. Elec. Co.)
26. von Glahn, Uwe, and Blatz, Robert E.: Investigation of Power Requirements for Ice Prevention and Cyclical De-Icing of Inlet Guide Vanes with Internal Electric Heaters. NACA RM E50H29, 1950.
27. Hensley, Reece V., Rom, Frank E., and Koutz, Stanley L.: Effect of Heat and Power Extraction on Turbojet-Engine Performance. I - Analytical Method of Performance Evaluation with Compressor-Outlet Air Bleed. NACA TN 2053, 1950.
28. Koutz, Stanley L., Hensley, Reece V., and Rom, Frank E.: Effect of Heat and Power Extraction of Turbojet-Engine Performance. III - Analytical Determination of Effects of Shaft-Power Extraction. NACA TN 2202, 1950.
29. Dallas, Thomas, and Ellisman, C.: Analysis and Preliminary Investigation of Eddy-Current Heating for Icing Protection of Axial-Flow-Compressor Blades. NACA RM E9E06, 1949.
30. Callaghan, Edmund E., and Ruggeri, Robert S.: Investigation of the Penetration of an Air Jet Directed Perpendicularly to an Air Stream. NACA TN 1615, 1948.

31. Callaghan, Edmund E., Ruggeri, Robert S., and Krebs, Richard P.: Experimental Investigation of Hot-Gas Bleedback for Ice Protection of Turbojet Engines. I - Nacelle with Offset Air Inlet. NACA RM E8D13, 1948.
32. Callaghan, Edmund E., and Ruggeri, Robert S.: Experimental Investigation of Hot-Gas Bleedback for Ice Protection of Turbojet Engines. II - Nacelle with Long Straight Air Inlet. NACA RM E9C16, 1949.
33. Ruggeri, Robert S., and Callaghan, Edmund E.: Experimental Investigation of Hot-Gas Bleedback for Ice Protection of Turbojet Engines. III - Nacelle with Short Straight Air Inlet. NACA RM E9E12, 1949.
34. Callaghan, Edmund E., and Bowden, Dean T.: Investigation of Flow Coefficient of Circular, Square, and Elliptical Orifices at High Pressure Ratios. NACA TN 1947, 1949.
35. Ruggeri, Robert S., Callaghan, Edmund E., and Bowden, Dean T.: Penetration of Air Jets Issuing from Circular, Square, and Elliptical Orifices Directed Perpendicularly to an Air Stream. NACA TN 2019, 1950.
36. von Glahn, Uwe: Ice Protection of Turbojet Engines by Inertia Separation of Water. I - Alternate-Duct System. NACA RM E8A27, 1948.
37. von Glahn, Uwe: Ice Protection of Turbojet Engines by Inertia Separation of Water. III - Annular Submerged Inlets. NACA RM E8A29, 1948.
38. Ruggeri, Robert S., von Glahn, Uwe, and Rollin, Vern G.: Investigation of Aerodynamic and Icing Characteristics of Recessed Fuel-Vent Configurations. NACA TN 1789, 1949.

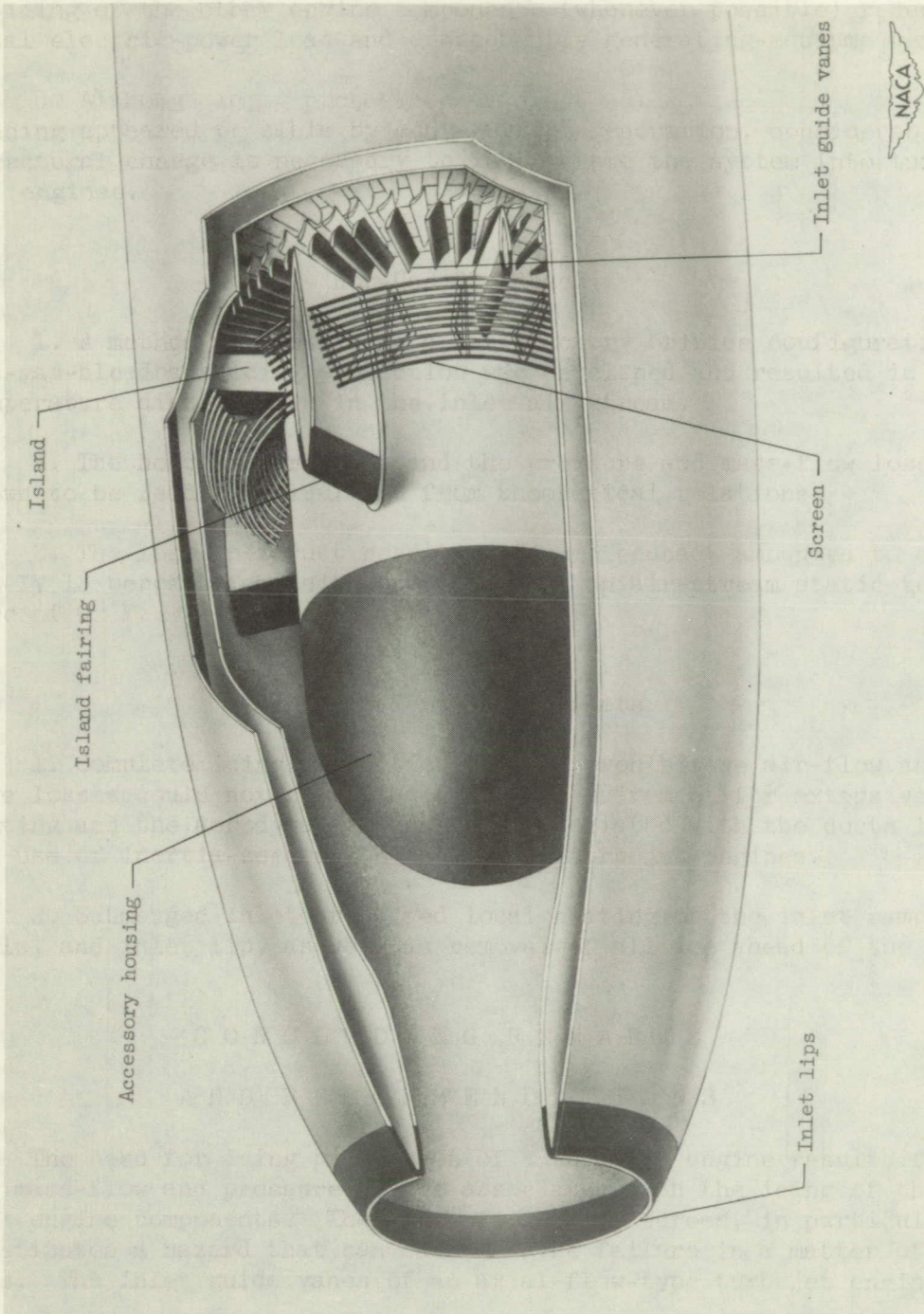

Figure 1. - Sketch of typical turbojet-engine installation showing surfaces requiring icing protection.

**Page intentionally left blank**

*Pages 34 — 50 (every other page left blank)*

**Page intentionally left blank**

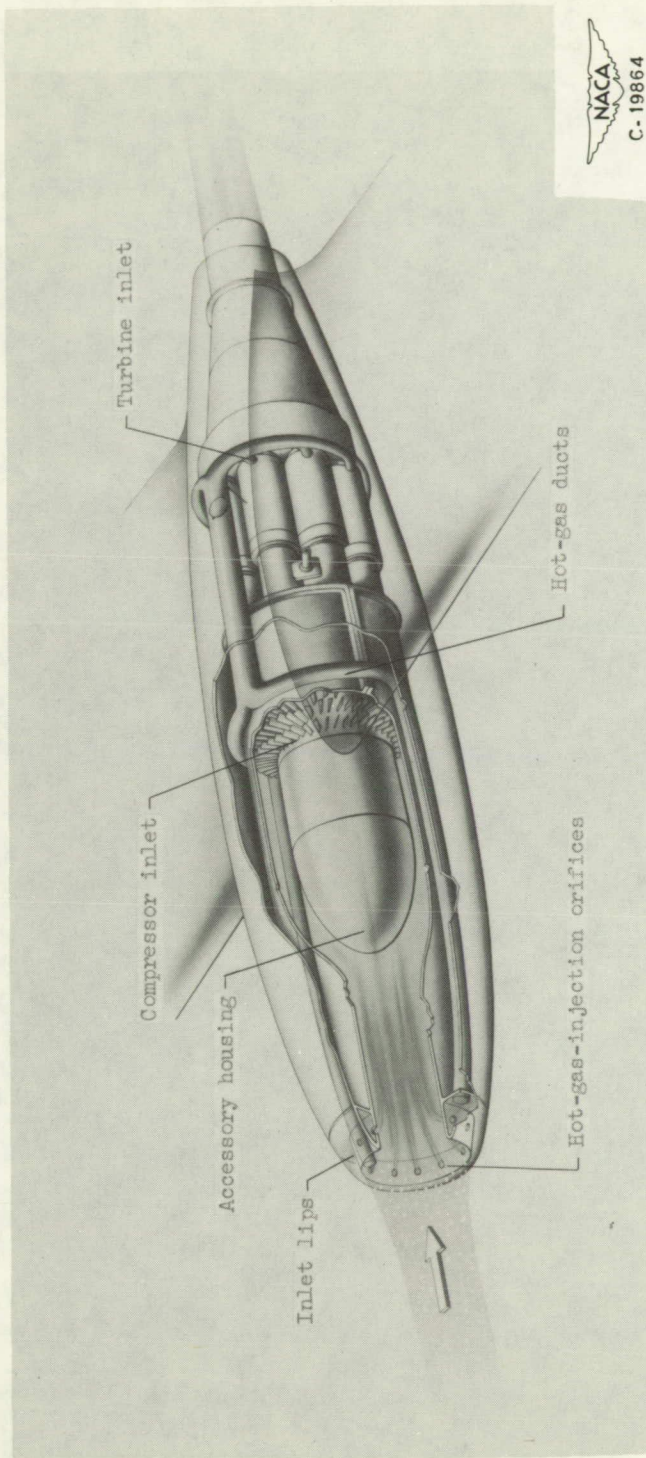

Figure 2. - Sketch of typical turbojet-engine icing-protection system using hot-gas injection into inlet air stream.

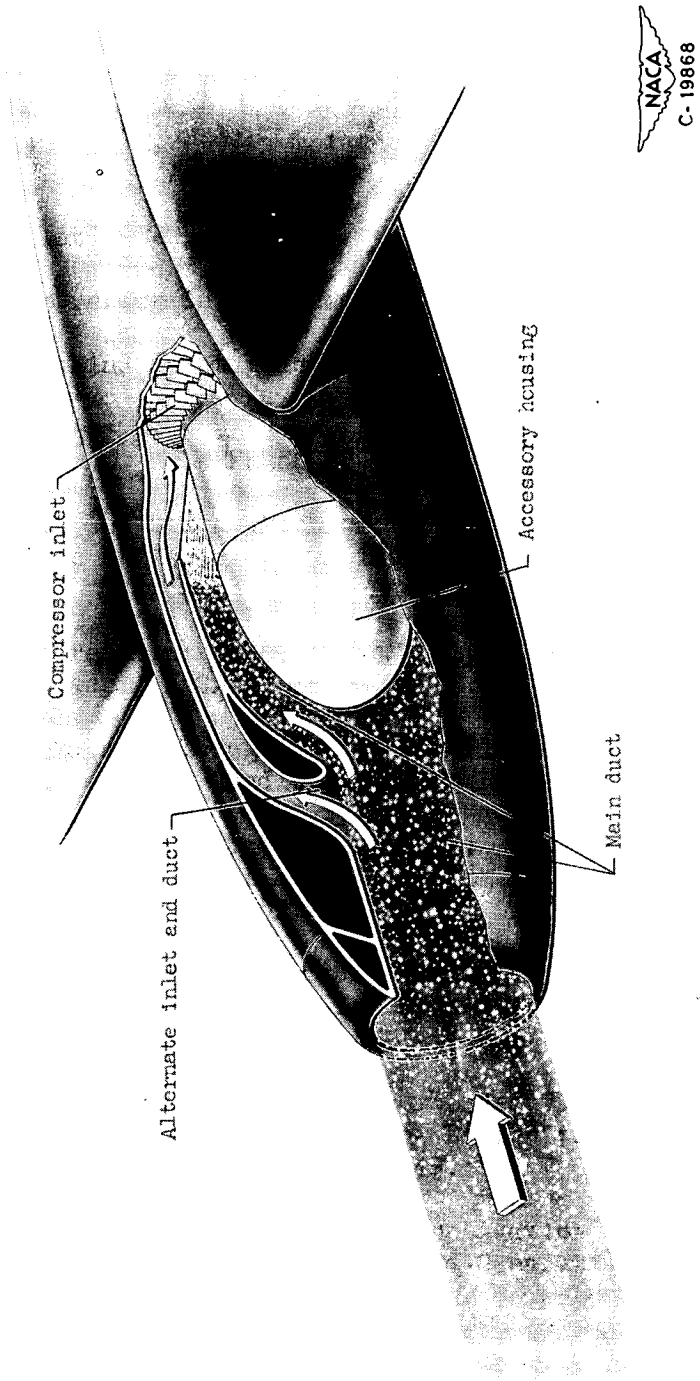

Figure 3. - Sketch of typical turbojet-engine icing-protection system using inertia separation at inlet.

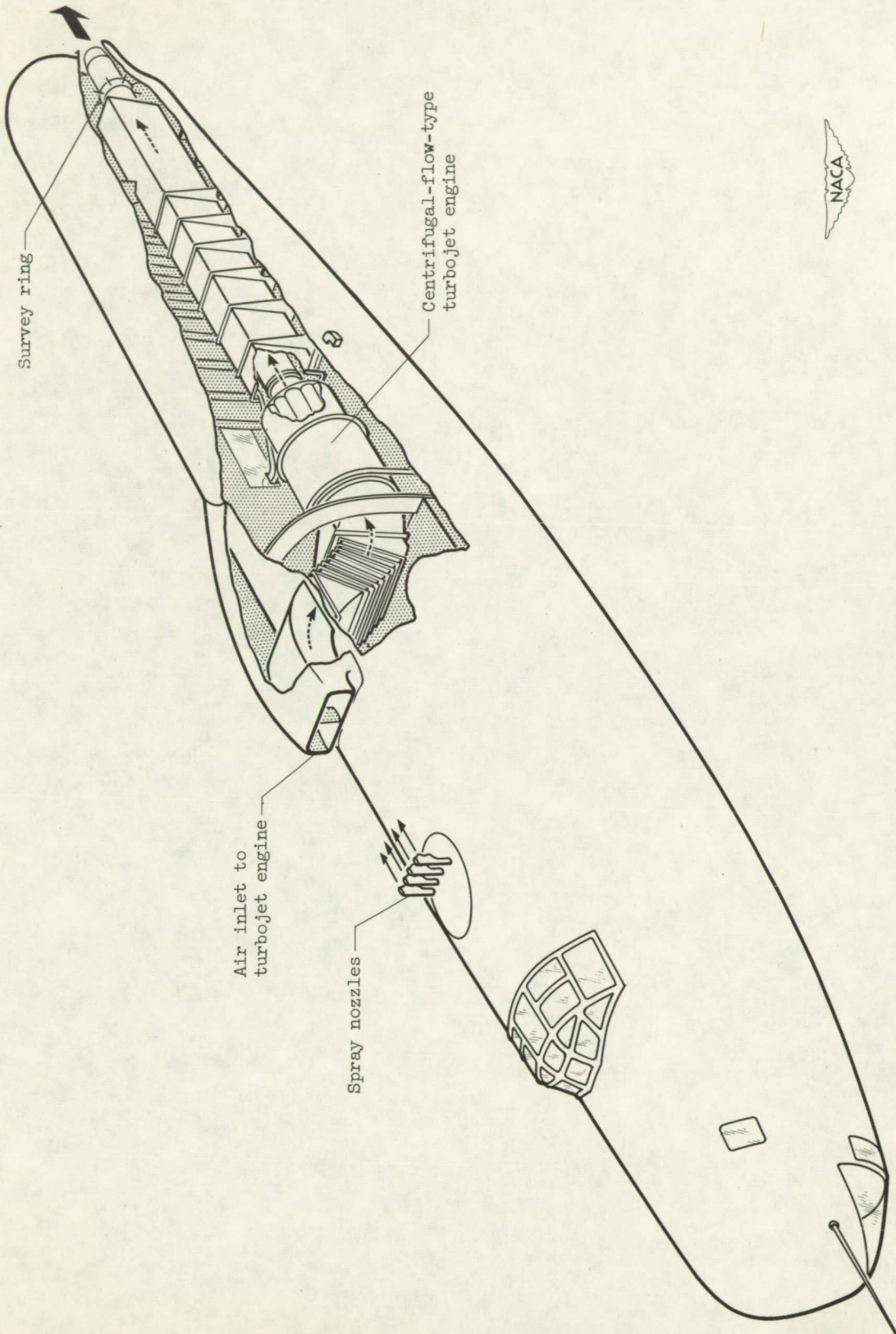

Figure 4. - Installation of double-entry centrifugal-flow-type turbojet engine in waist compartment of large four-engine bomber-type aircraft fuselage.



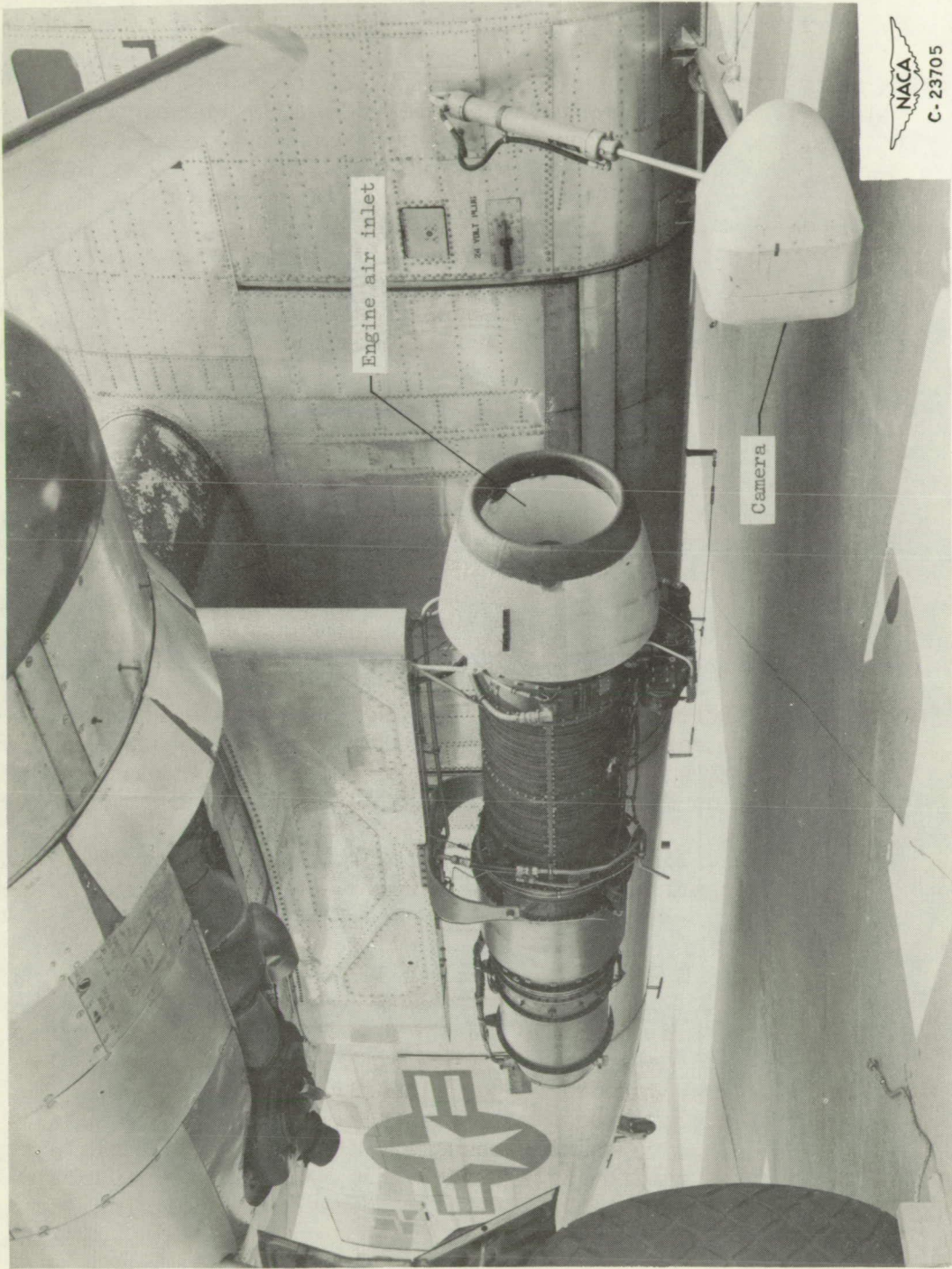

Figure 5. - Installation of axial-flow-type turbojet engine below wing of large four-engine bomber-type aircraft.

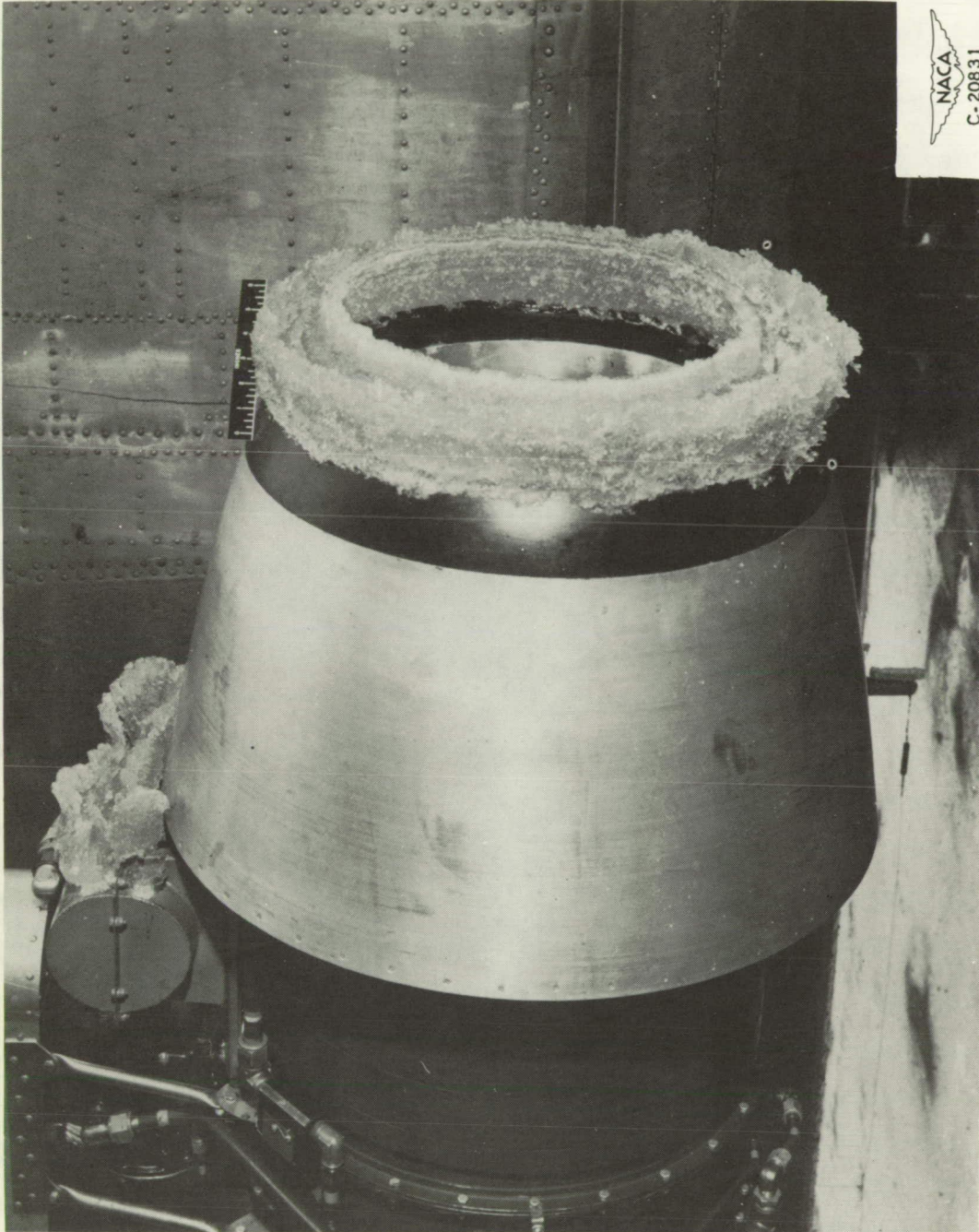
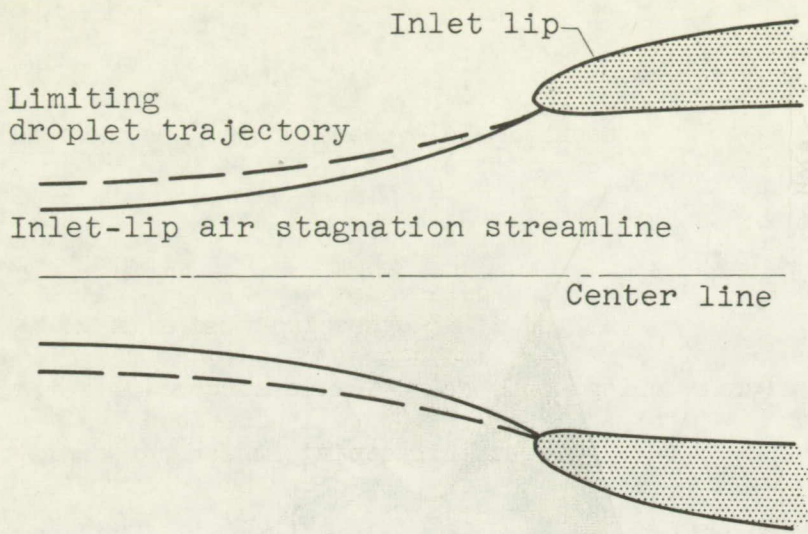
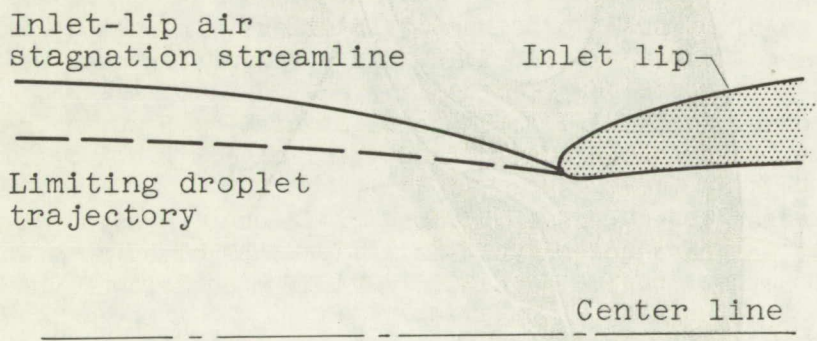

Figure 6. - Typical double-peaked glaze-ice formation on inlet lips of turbojet-engine installation.



(a) Inlet-air-velocity ratio less than 1.0.



(b) Inlet-air-velocity ratio greater than 1.0.

Figure 7. - Sketch illustrating effect of inlet-air-velocity ratio on scooping of cloud droplets into inlet.

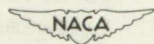

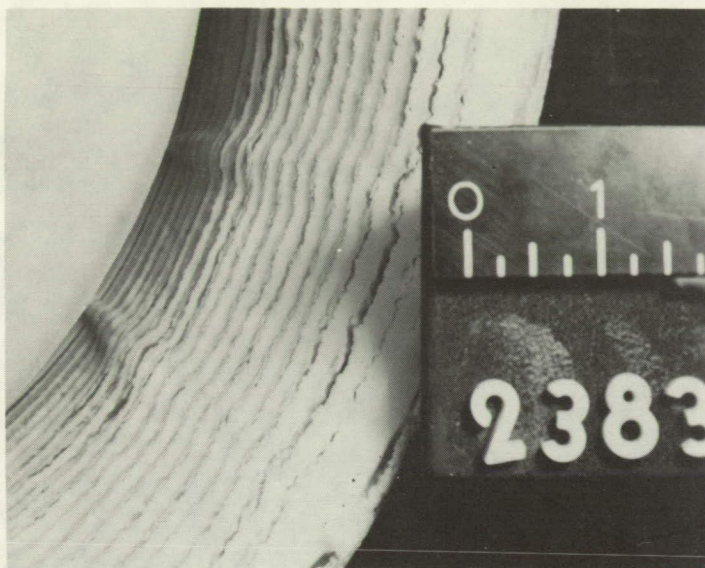

(a) Circumferential round-wire axial-flow-type compressor-inlet screen; initial air velocity ahead of screen, 250 feet per second; inlet-air total temperature,  $10^{\circ}$  F; liquid-water content, approximately 0.6 gram per cubic meter; icing time, 12 minutes.

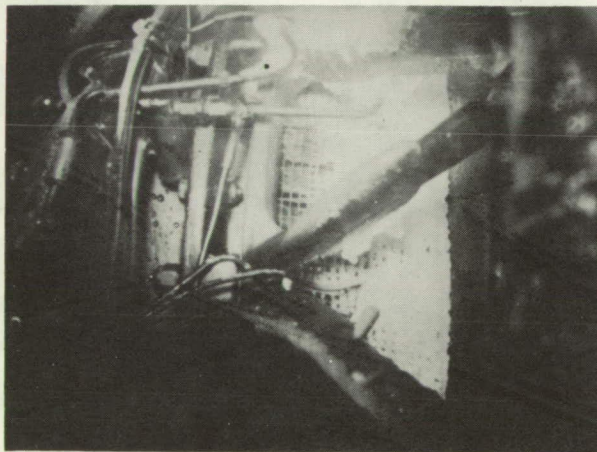

(b) Front compressor-inlet screen of centrifugal-flow-type engine; flight speed, 180 miles per hour; inlet-air total temperature,  $15^{\circ}$  F; liquid-water content, 0.3 to 0.4 gram per cubic meter; icing time, .27 minutes.

Figure 8. - Typical ice formations on two representative compressor-inlet screens.

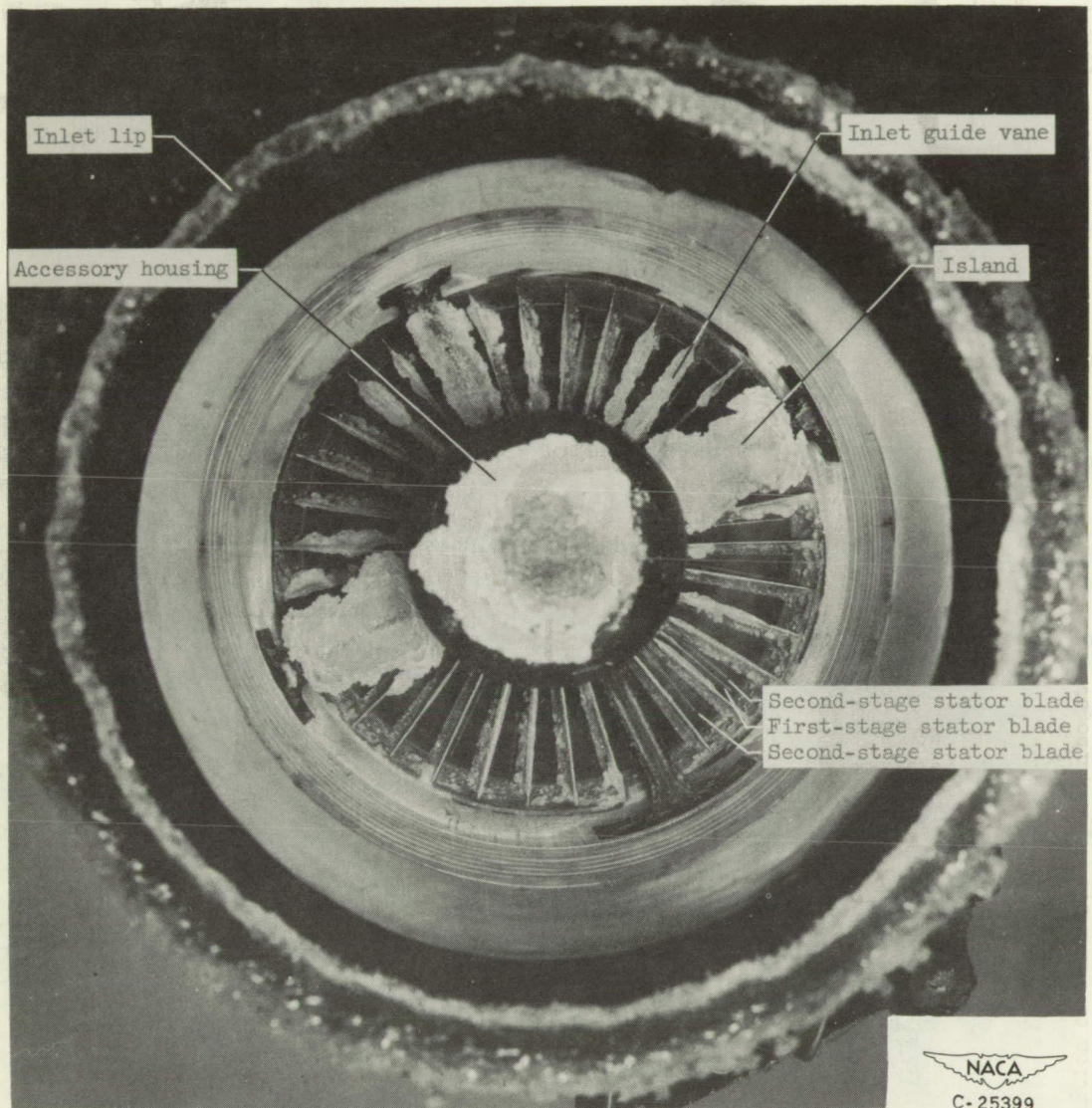

Figure 9. - Ice formations on axial-flow-type turbojet-engine inlet at rated engine speed; flight speed, 165 to 180 miles per hour; ambient-air temperature, 25° F; liquid-water content, 0.4 to 0.6 gram per cubic meter; mean drop diameter, 11 to 16 microns; icing time, 22 minutes; thrust loss, 18 percent.

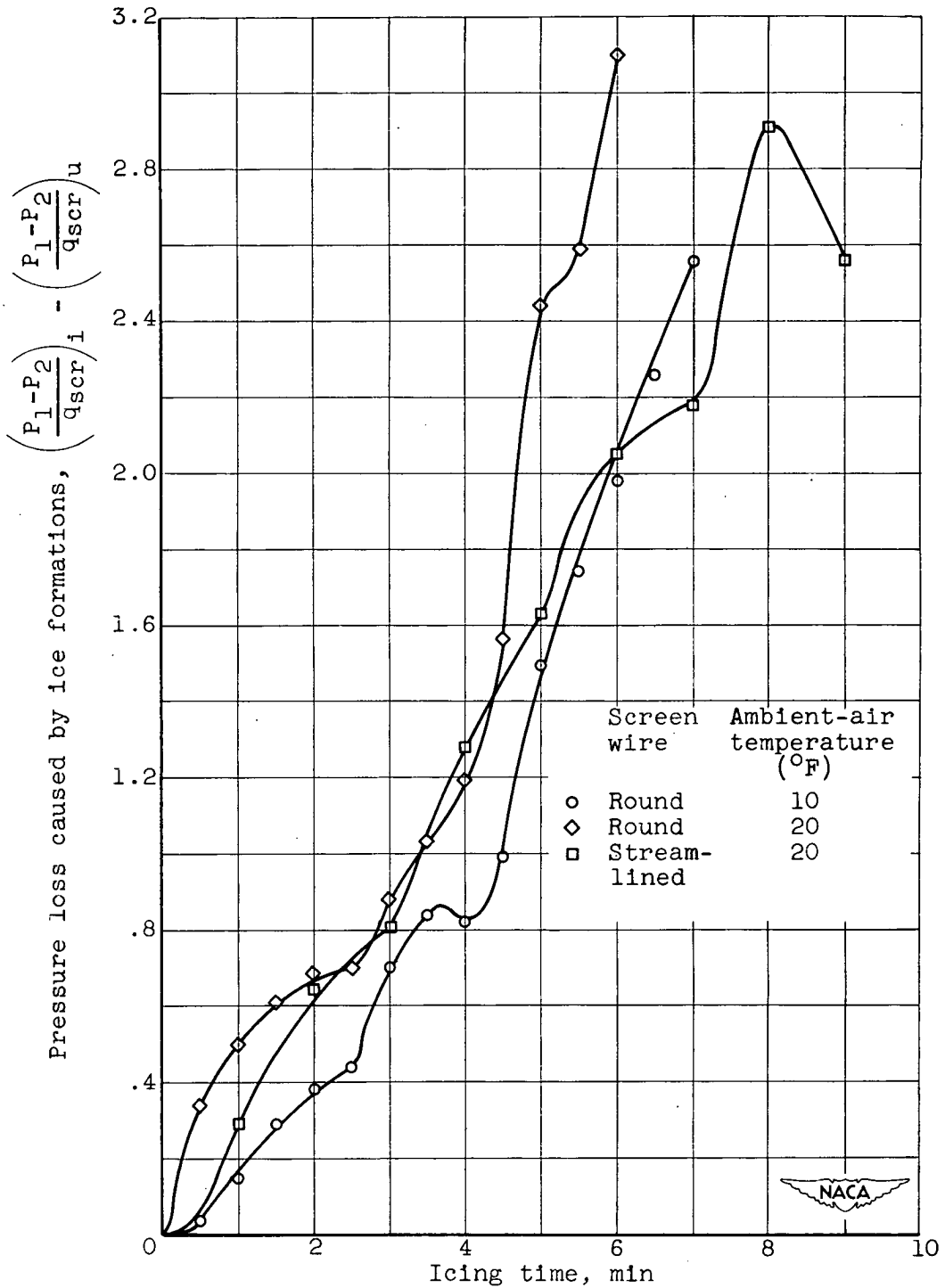
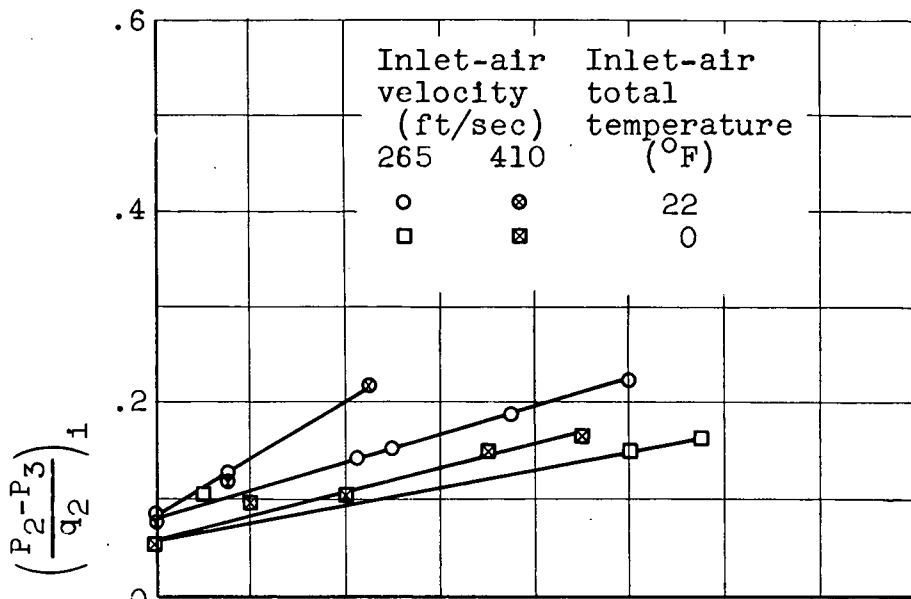
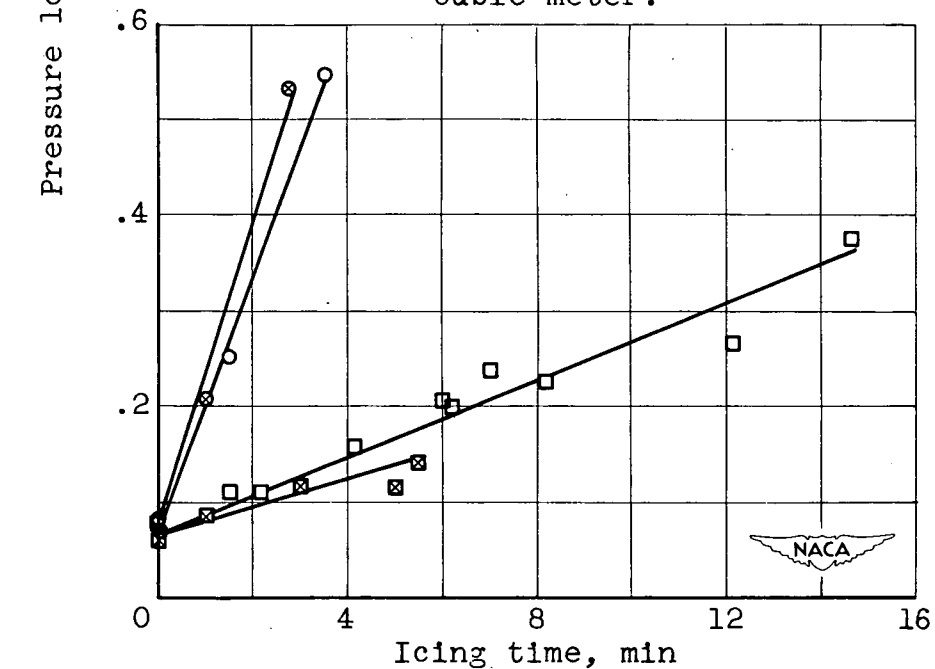

Figure 10. - Pressure losses associated with axial-flow-type compressor-inlet-screen and component icing as a function of icing time. Initial air velocity ahead of screen, 375 feet per second; liquid-water content, 0.6 gram per cubic meter.



(a) Liquid-water content, 0.4 gram per cubic meter.



(b) Liquid-water content, 0.9 gram per cubic meter.

Figure 11. - Pressure loss across cascade of unheated guide vanes as function of icing time.

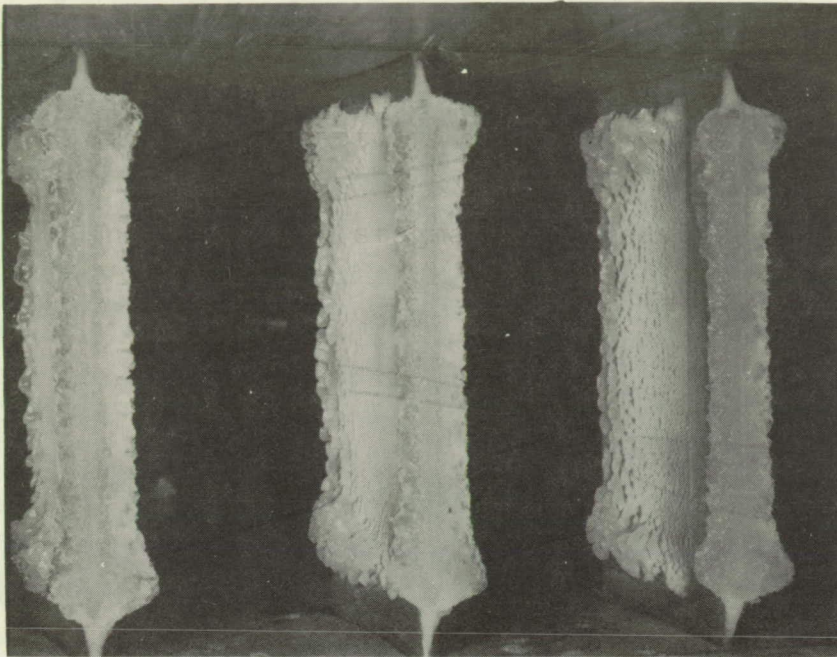

(a) Glaze-ice formations; inlet-air total temperature, 22° F; icing time, 3½ minutes.

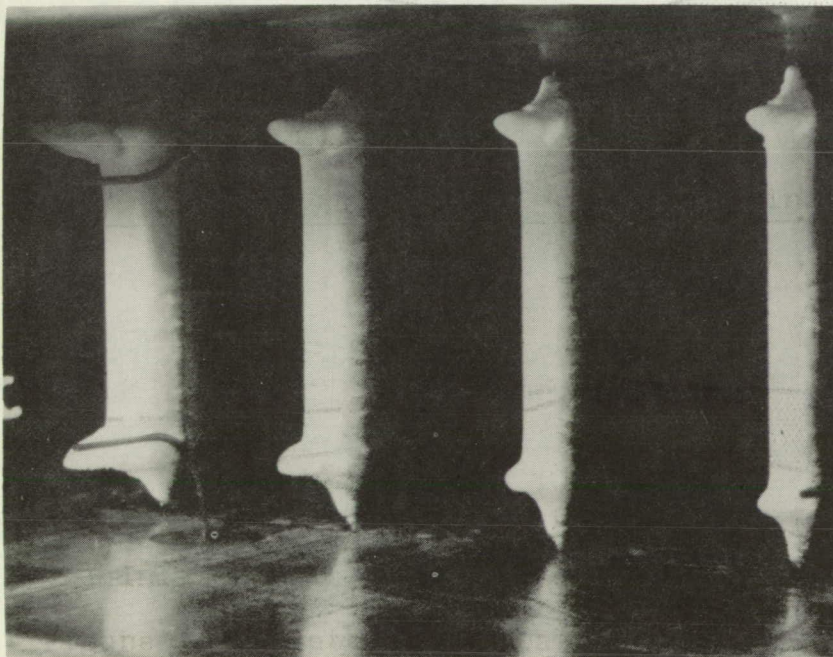

(b) Rime-ice formations; inlet-air total temperature, 0° F; icing time, 7 minutes.

Figure 12. - Typical rime and glaze icing on an inlet-guide-vane cascade; inlet-air velocity, 265 feet per second; liquid-water content, 0.9 gram per cubic meter.



**Page intentionally left blank**

**Page intentionally left blank**

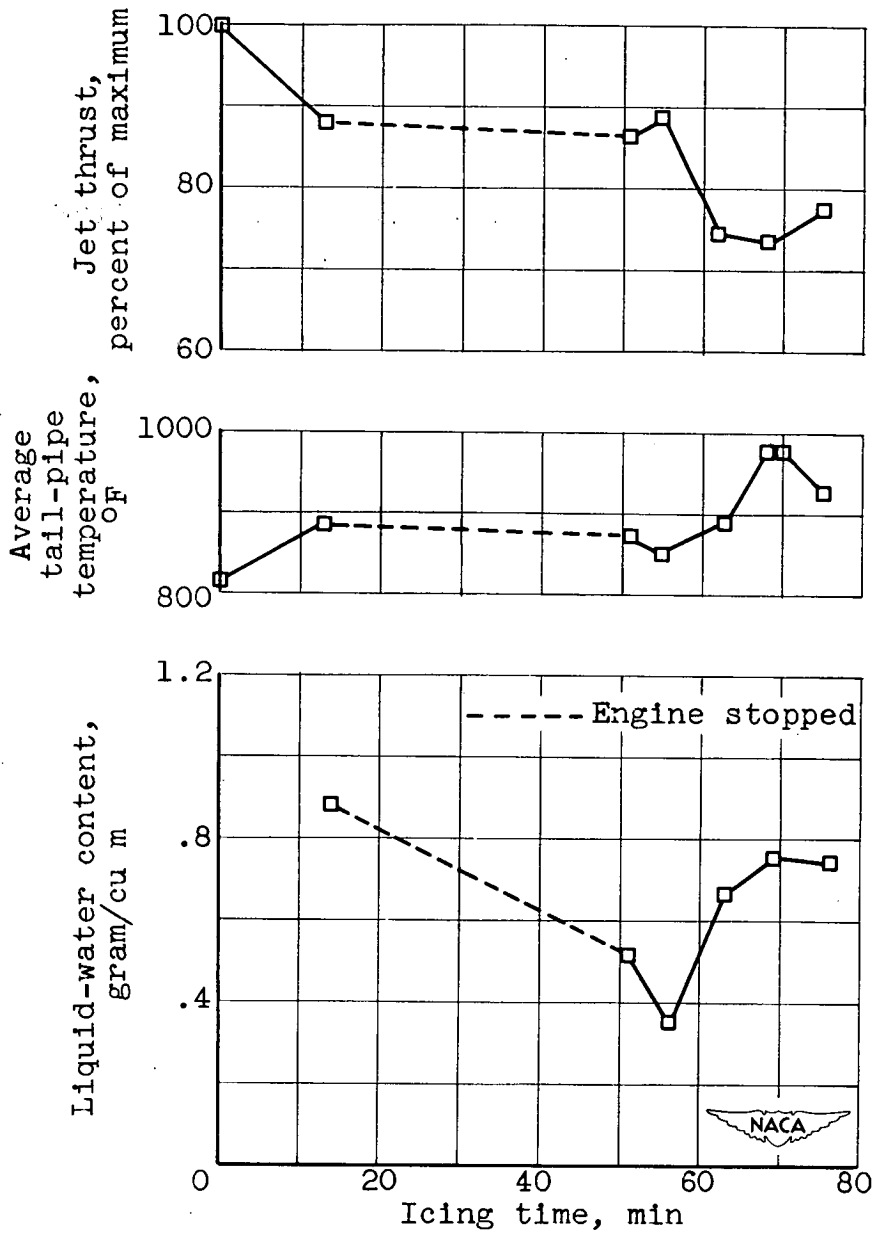
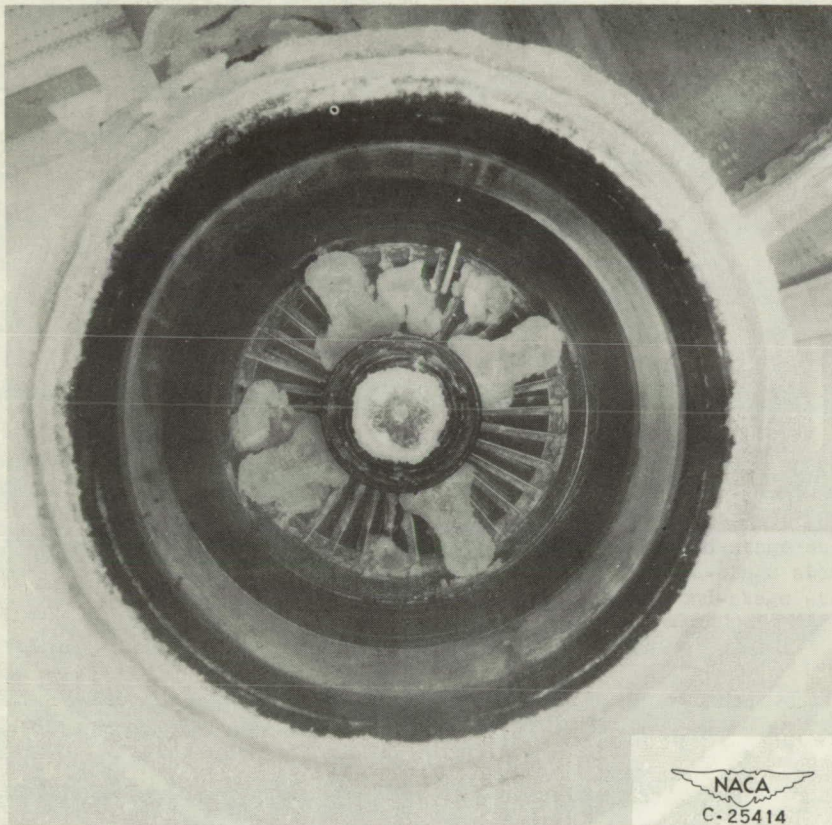

Figure 13. - Time history of flight data obtained with axial-flow-type engine in icing condition at 92 percent of rated engine speed. Indicated flight speed, 173 to 185 miles per hour; ambient-air temperature, 17° to 22° F; mean drop diameter, 12 to 14 microns; pressure altitude, 4600 to 5900 feet.

**Page intentionally left blank**

**Page intentionally left blank**



NACA  
C-25414

Figure 14. - Ice formation on axial-flow-type turbojet-engine inlet during flight at 92 percent of rated engine speed. Indicated flight speed, 173 to 185 miles per hour; ambient-air temperature, 17° to 22° F; liquid-water content, 0.4 to 0.9 gram per cubic meter; effective icing time, 33 minutes; thrust loss, 26 percent.

Figure 15. - Ice formations on axial-flow-type turbojet-engine inlet at rated engine speed; flight speed, 165 to 180 miles per hour; ambient-air temperature, 25° F; liquid-water content, 0.4 to 0.8 gram per cubic meter; mean drop diameter, 11 to 16 microns; icing time, 22 minutes; thrust loss, 13 percent.

**Page intentionally left blank**

**Page intentionally left blank**

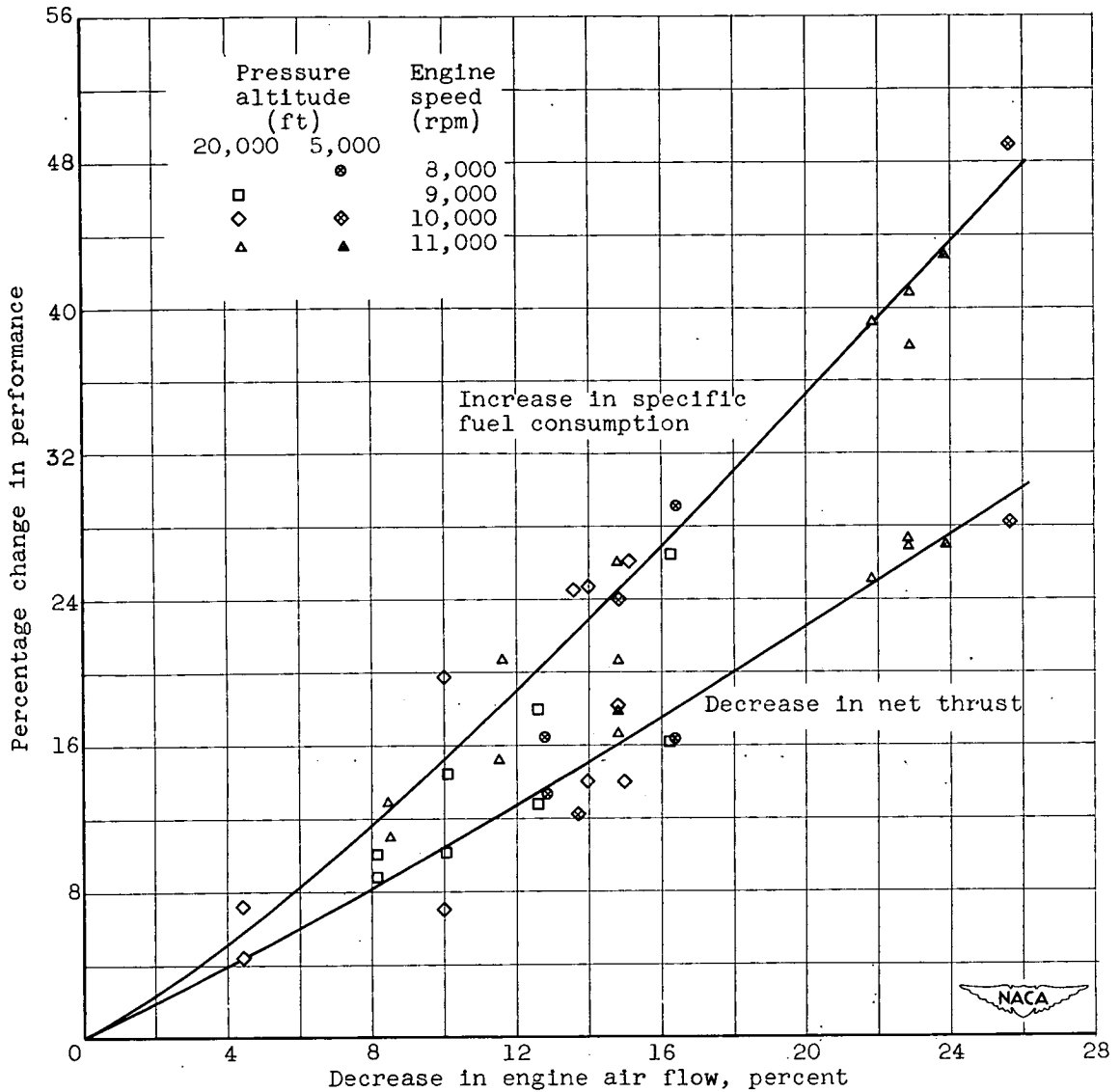

Figure 15. - Performance changes as function of decrease in air flow for axial-flow-type turbojet engine in icing conditions.

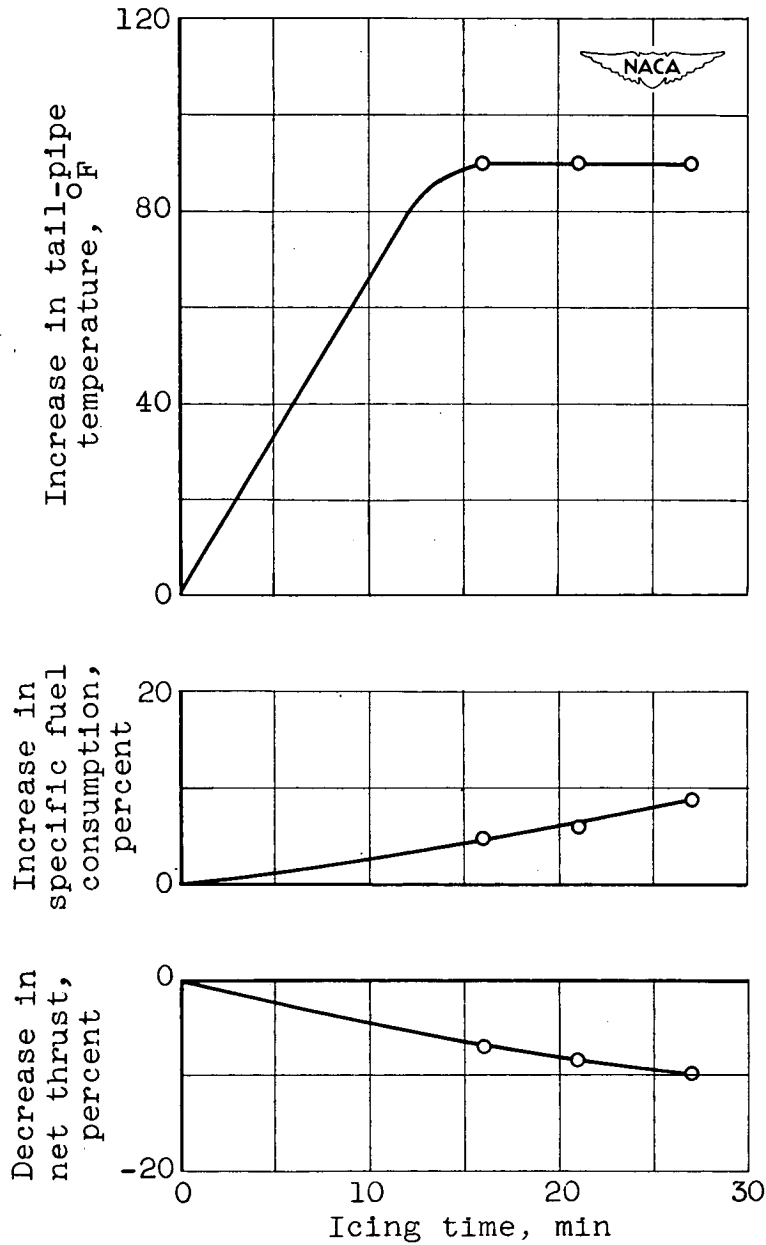
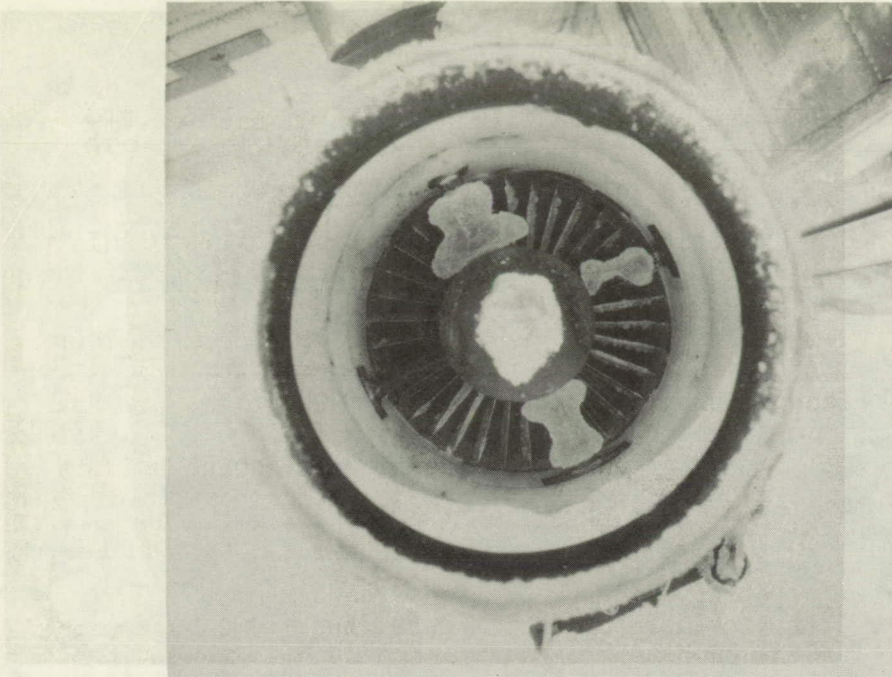
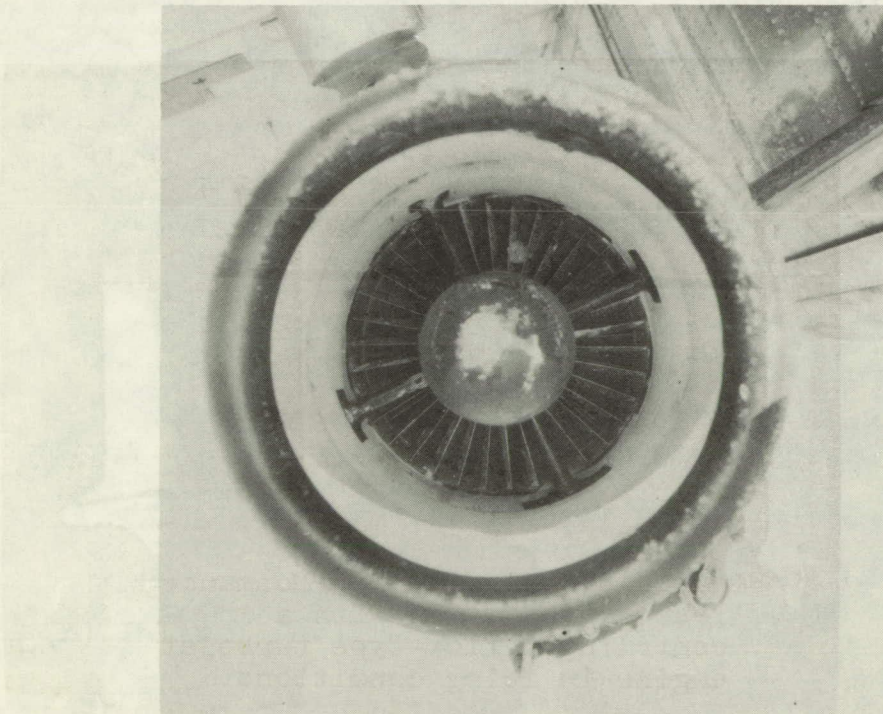

Figure 16. - Typical performance losses associated with a centrifugal-flow-type turbojet engine in icing conditions.



NACA  
C-25412

(a) 1 minute before shedding of ice formations.



NACA  
C-25413

(b) 1 minute after shedding of ice formations.

Figure 17. - Illustration of magnitude of ice formations that may shed from components and pass into turbojet engine.



**Page intentionally left blank**

**Page intentionally left blank**

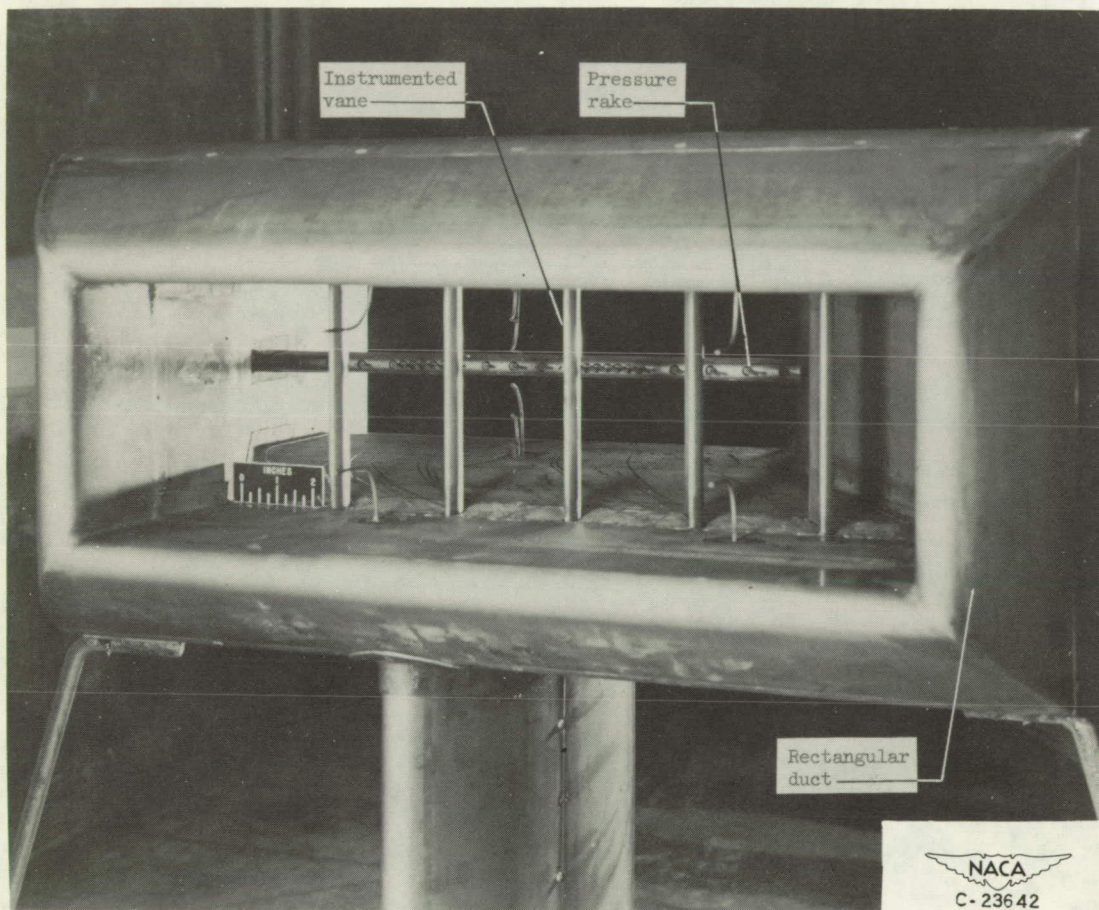
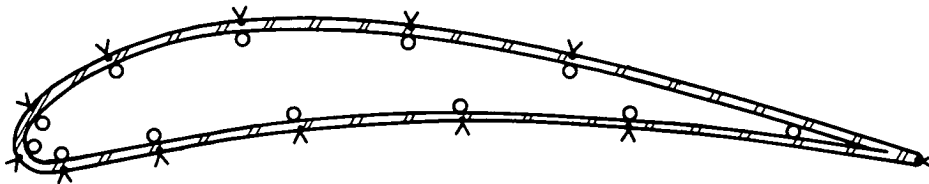

Figure 18. - Installation of inlet-guide-vane cascade in icing research tunnel.

**Page intentionally left blank**

**Page intentionally left blank**

v Thermocouple location  
o Thermocouple leads



(a) Vane 1: fully hollow.

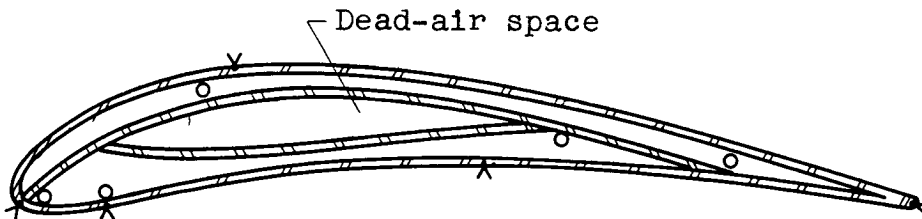

(b) Vane 2: internal fin and insert.

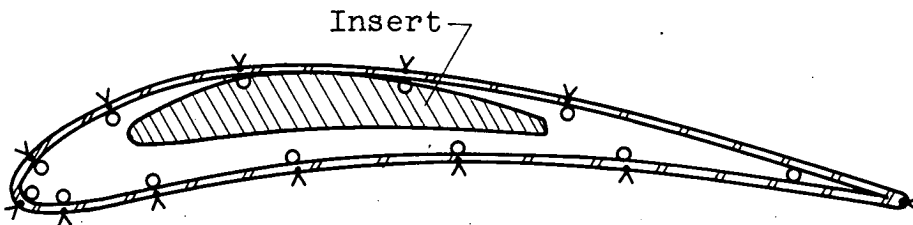

(c) Vane 3: internal insulating insert.



Figure 19. - Cross sections of gas-heated inlet guide vanes showing internal-passage configurations and thermocouple locations.

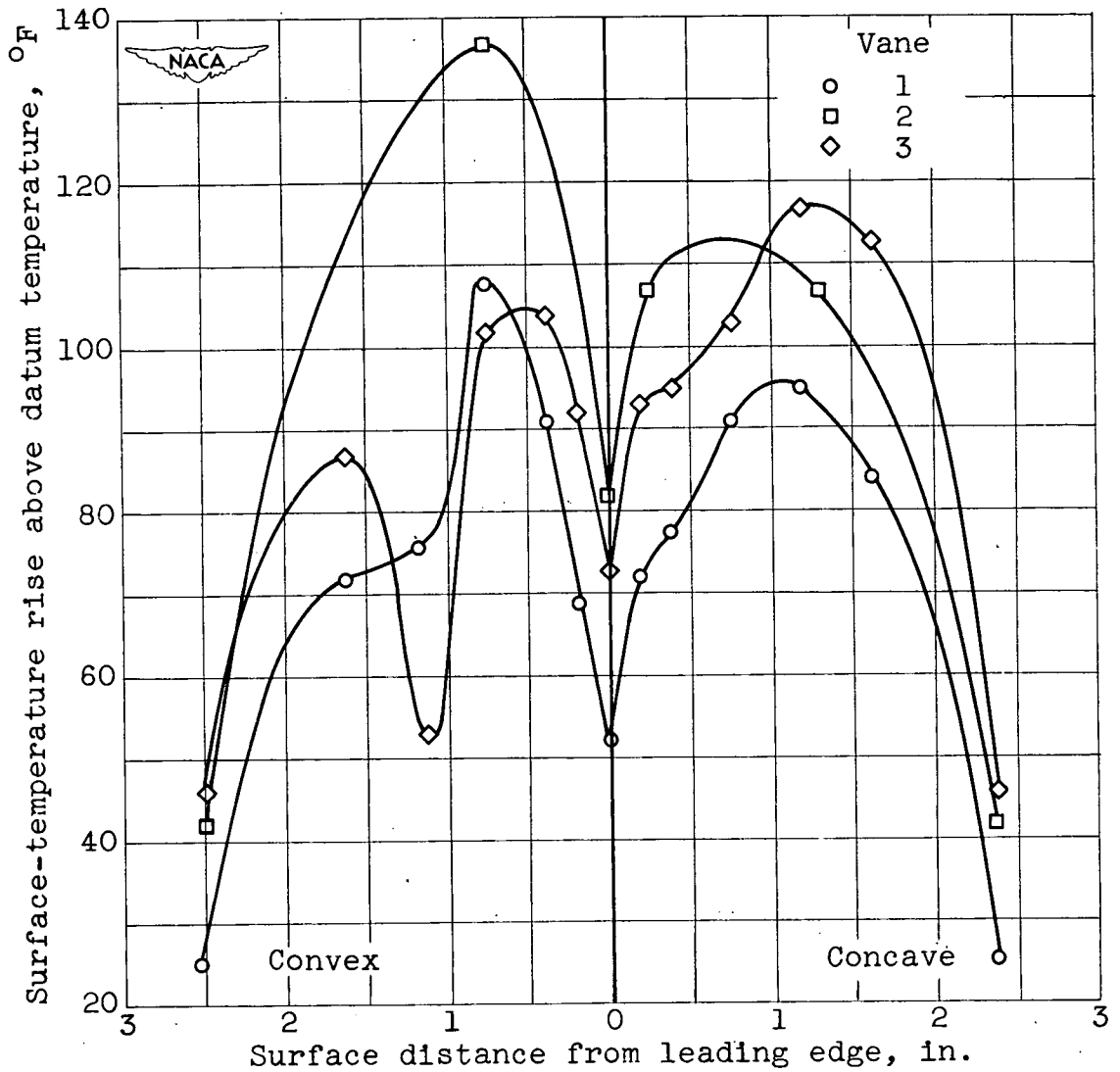

Figure 20. - Chordwise surface-temperature rise in dry air for three gas-heated-vane configurations. Air velocity ahead of vanes, 437 feet per second; gas flow, 120 pounds per hour; mean gas-temperature differential above datum temperature,  $195^{\circ}$  F.

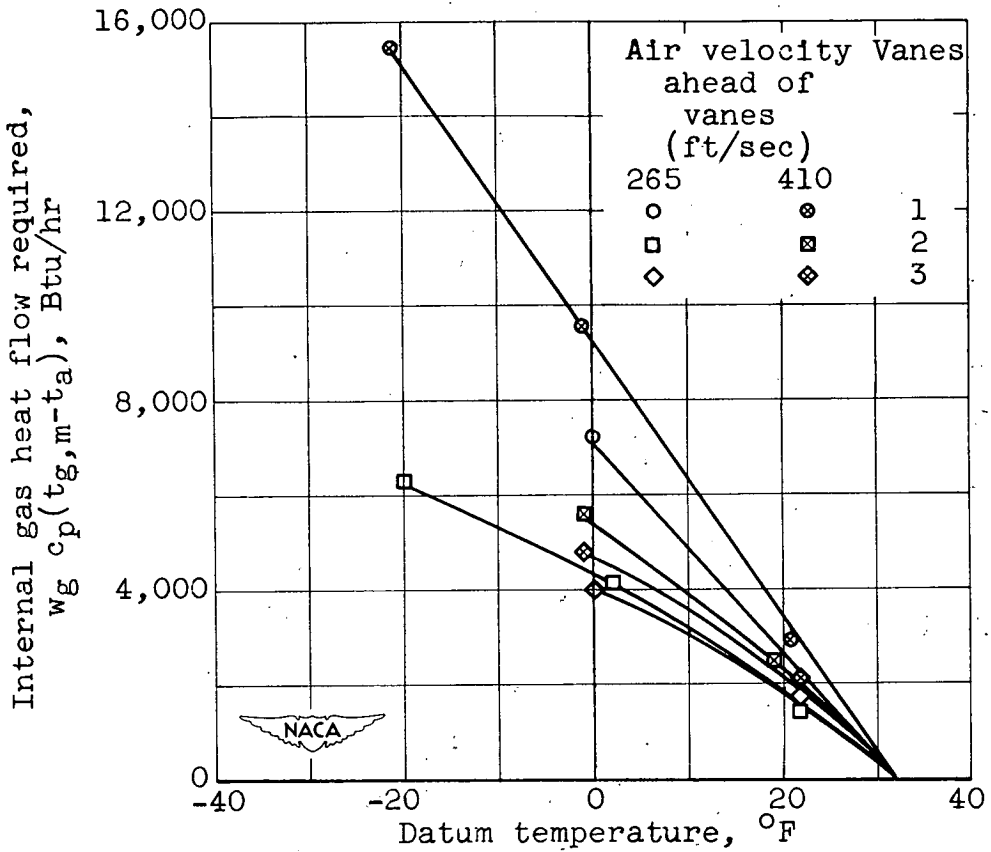

Figure 21. - Heating required to prevent icing at midspan of three vane configurations. Liquid-water content, 0.9 gram per cubic meter; assumed gas flow per unit internal passage area, 60,000 pounds per hour per square foot.

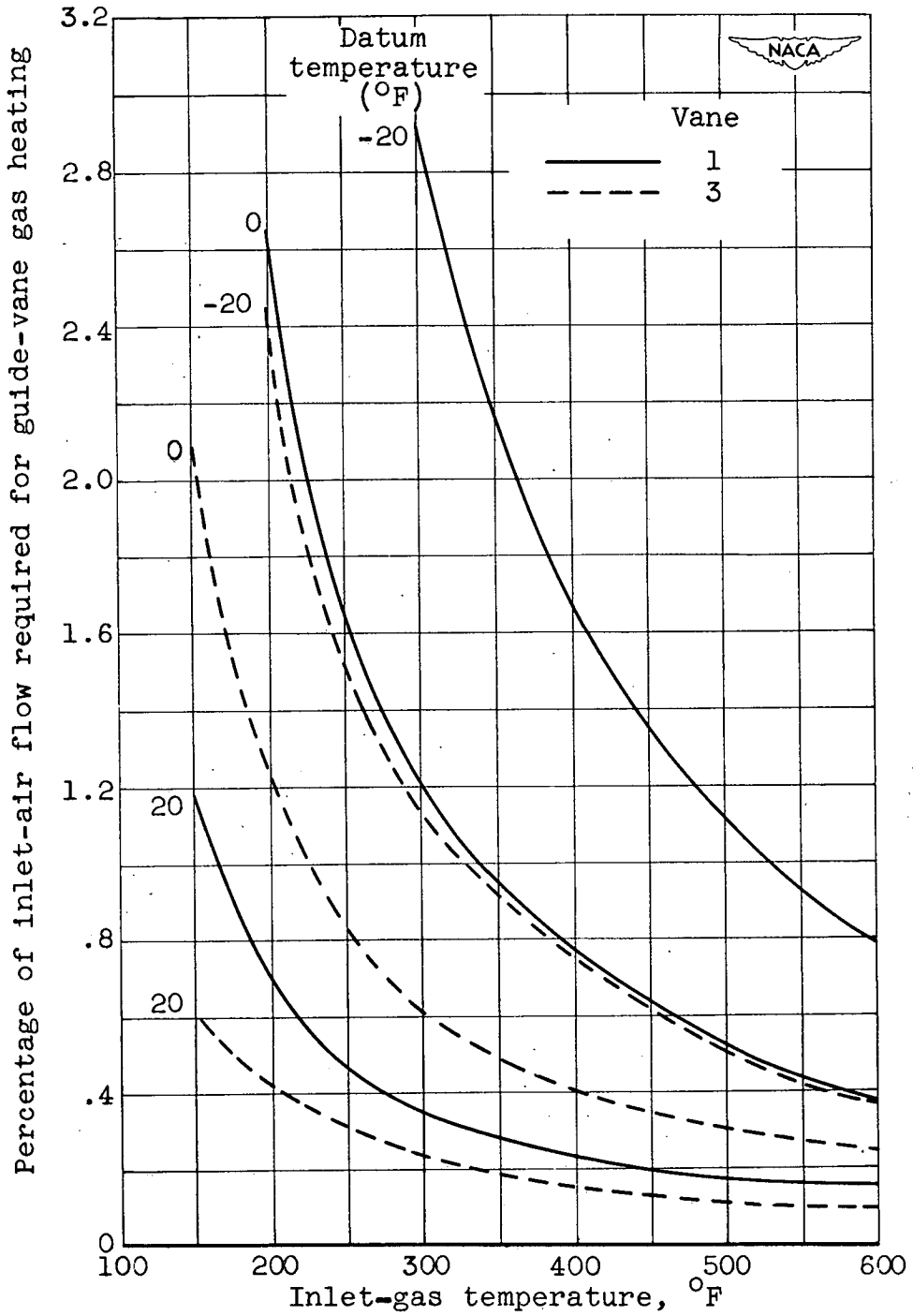

Figure 22. - Percentage of inlet air flow required for gas heating an inlet-guide-vane stage for ice prevention as a function of inlet-gas temperature. Air velocity ahead of vanes, 410 feet per second; liquid-water content, 0.9 gram per cubic meter.

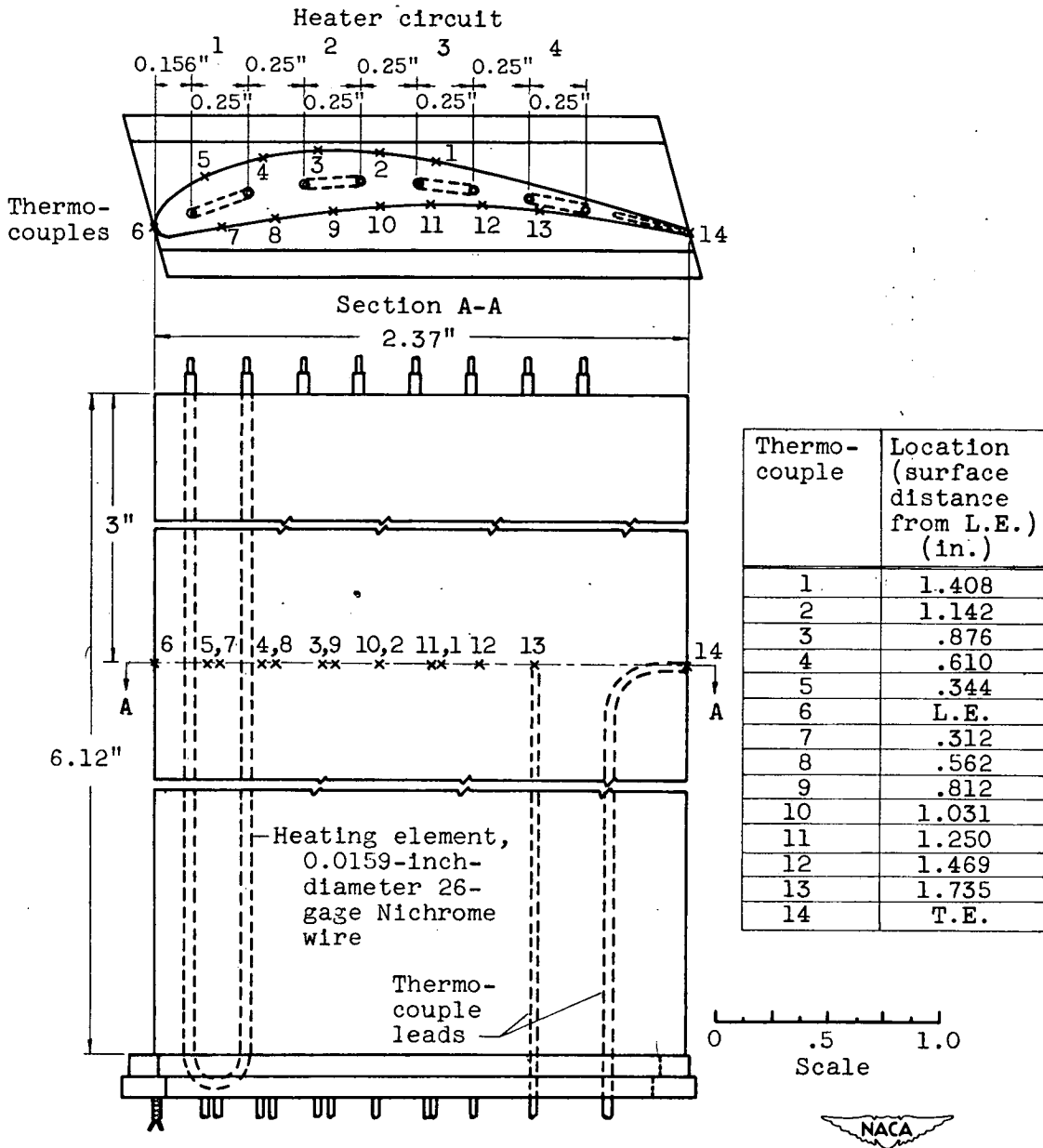
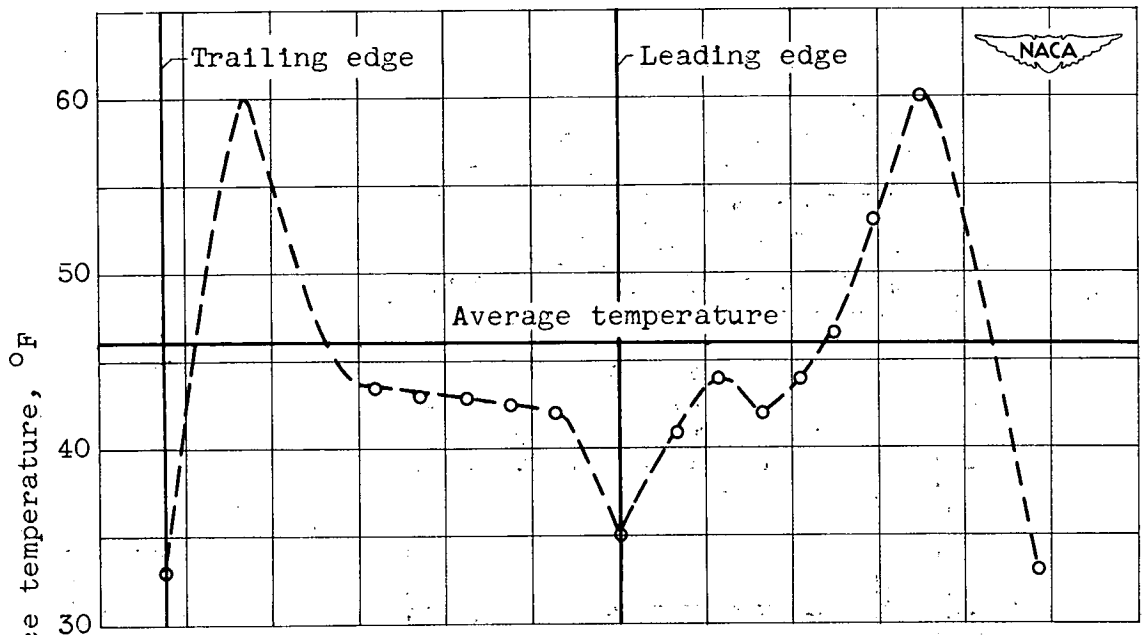
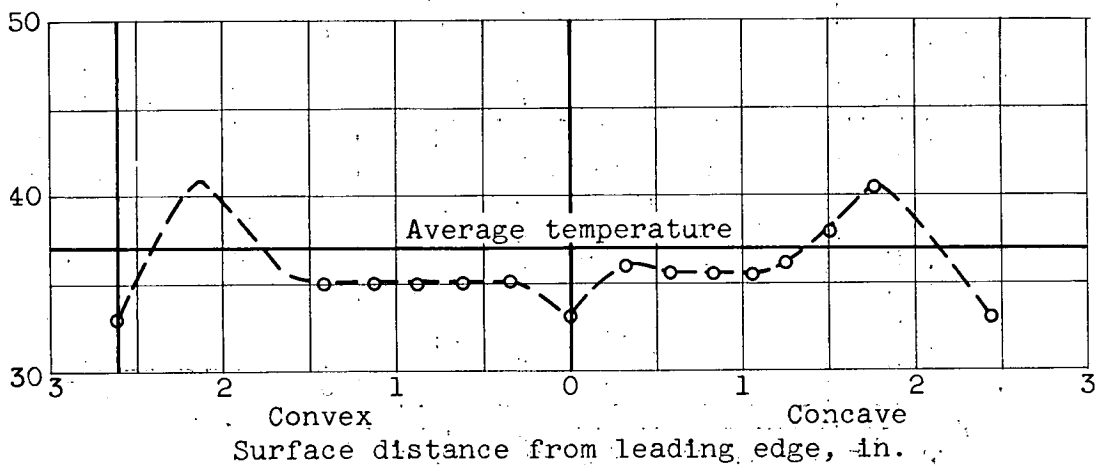

Figure 23. - Construction details of electrically heated inlet guide vane showing location of heater circuits and surface thermocouples.





(a) Datum temperature,  $-28^{\circ}$  F; liquid-water content, approximately 0.3 gram per cubic meter; average power density, 13.7 watts per square inch.



(b) Datum temperature,  $17^{\circ}$  F; liquid-water content, approximately 0.8 gram per cubic meter; average power density, 3.9 watts per square inch.

Figure 24. - Surface-temperature distribution along vane surfaces with continuous electrical heating. Inlet-air velocity, 400 feet per second.

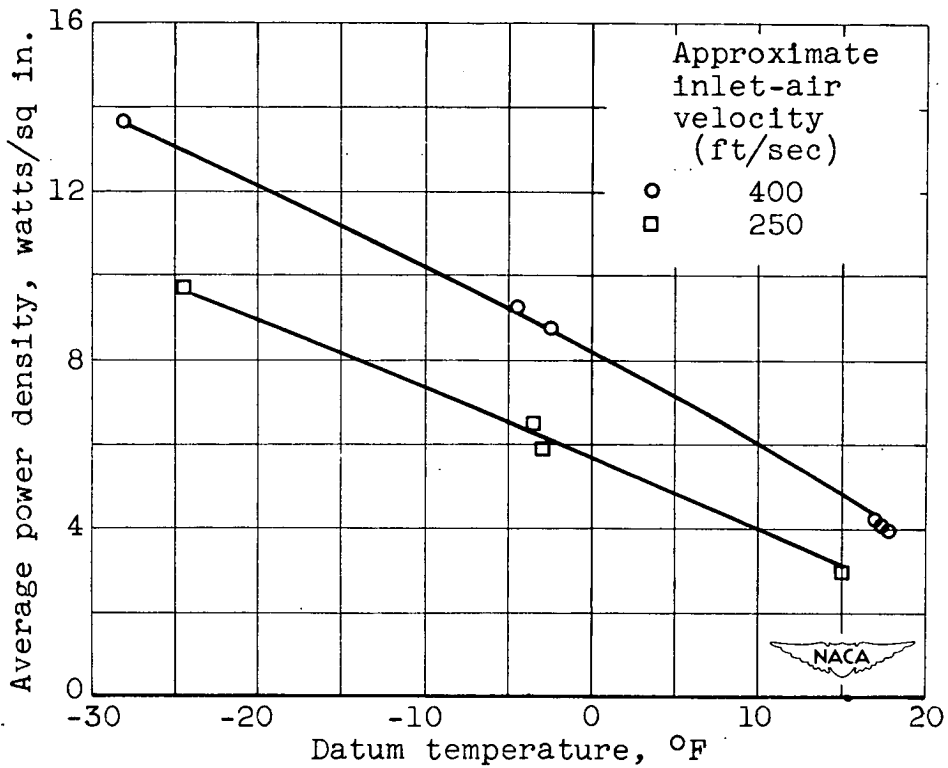
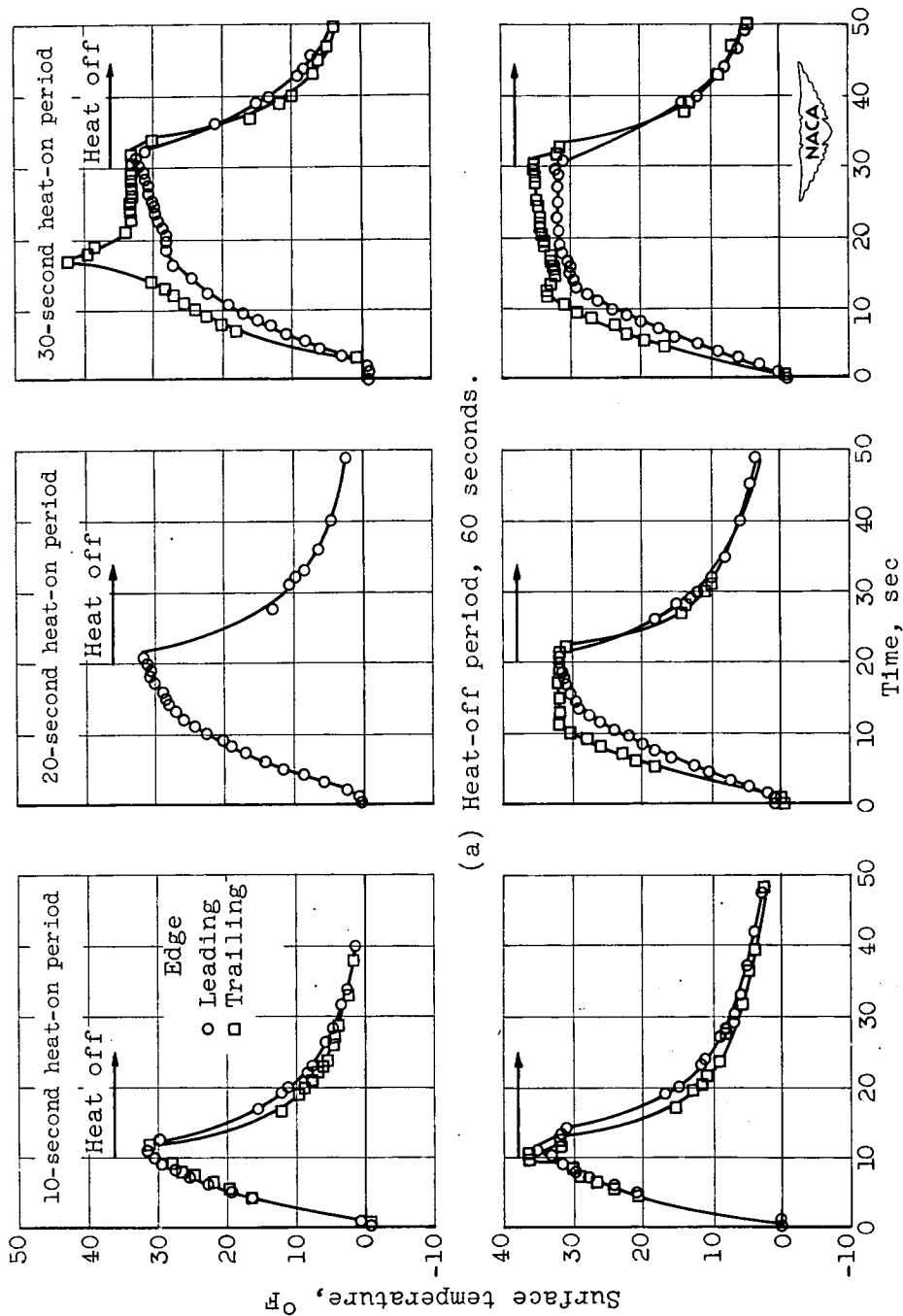

Figure 25. - Minimum power requirements for ice prevention with continuous heating of inlet guide vanes as function of datum temperature. Liquid-water content, 0.30 to 0.85 gram per cubic meter.



(a) Heat-on period, 60 seconds.

(b) Heat-off period, 120 seconds.

Figure 26. - Typical surface-temperature-rise curves at guide-vane leading and trailing edges with cyclical electrical heating for various heat-on periods as function of time. Inlet-air velocity, approximately 392 feet per second; ambient-air temperature, -11° F; liquid-water content, approximately 0.6 gram per cubic meter.

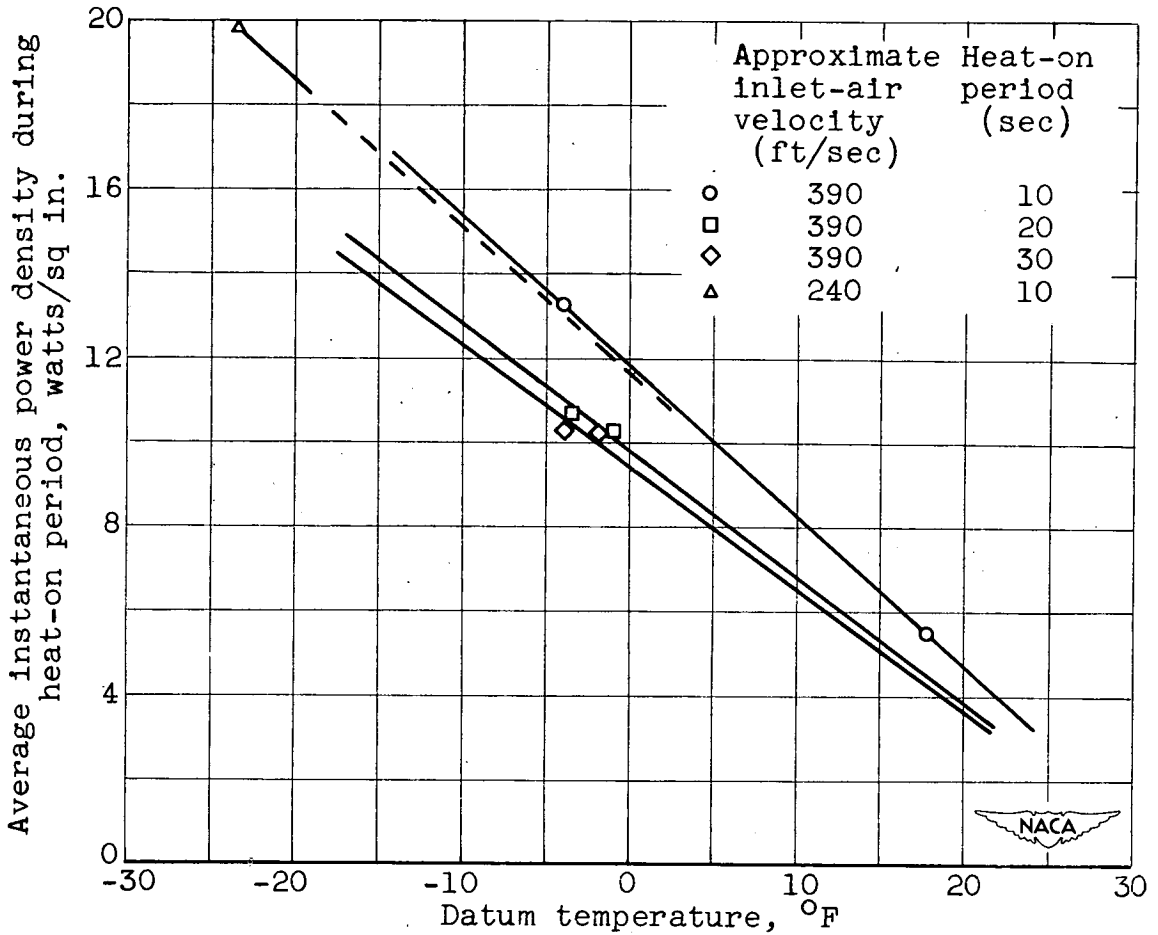
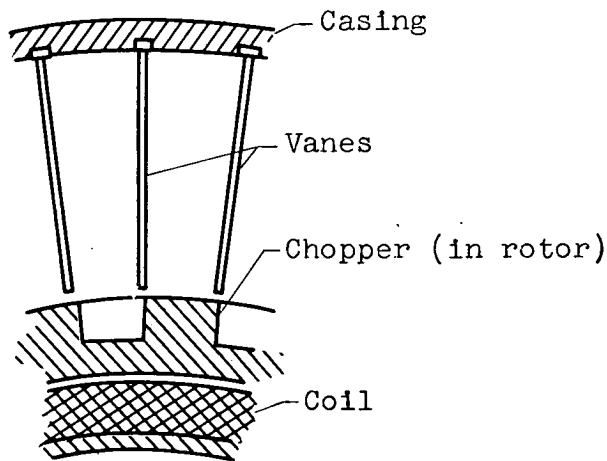
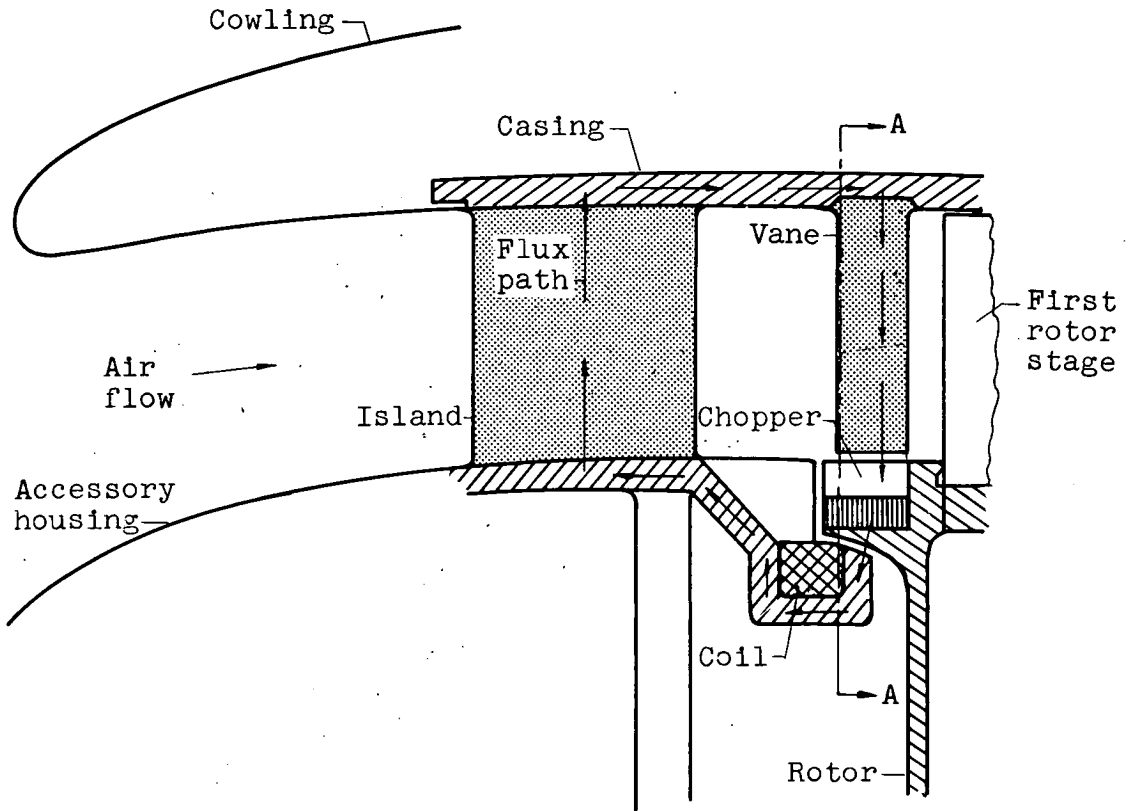

Figure 27. - Variation of average instantaneous power density required for ice removal with cyclical electrical de-icing of inlet guide vanes as function of datum temperature. Liquid-water content, 0.3 to 0.8 gram per cubic meter; heat-off periods, 60 to 120 seconds.



Section A-A



Figure 28. - Schematic diagram of eddy-current heating for inlet guide vanes.

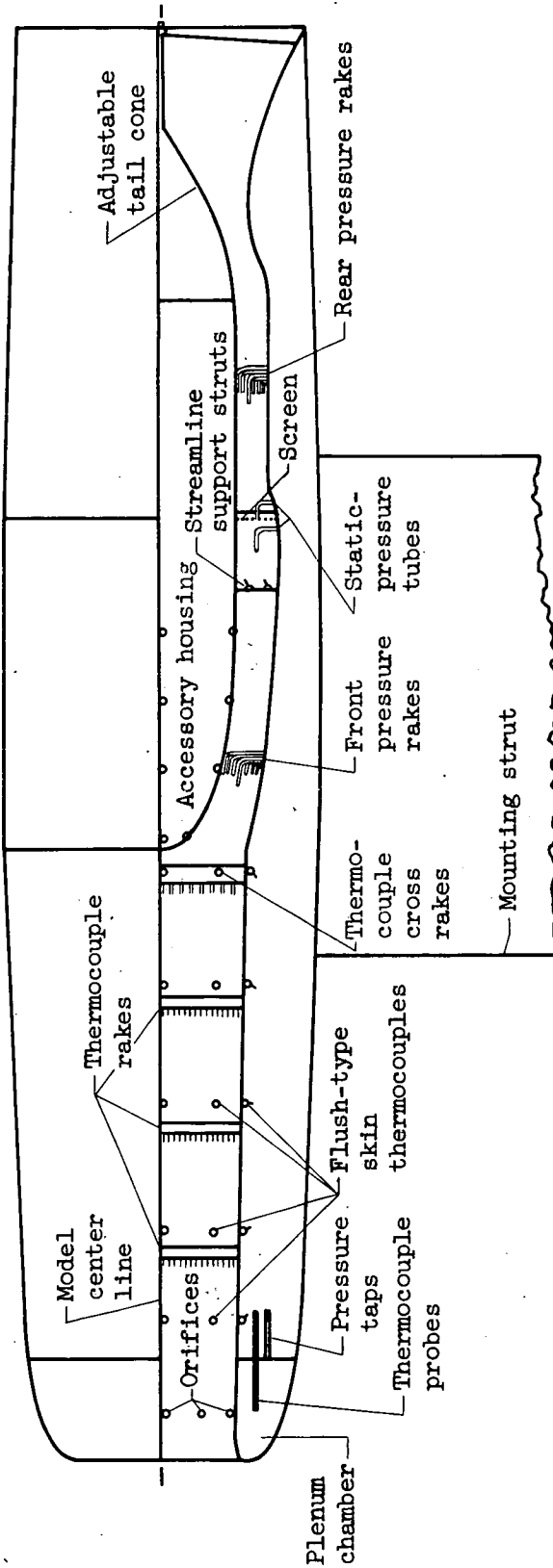

Figure 29. - Sketch of long, straight inlet used for investigation of hot-gas bleedback. Instrumentation shown is typical of all inlets investigated.

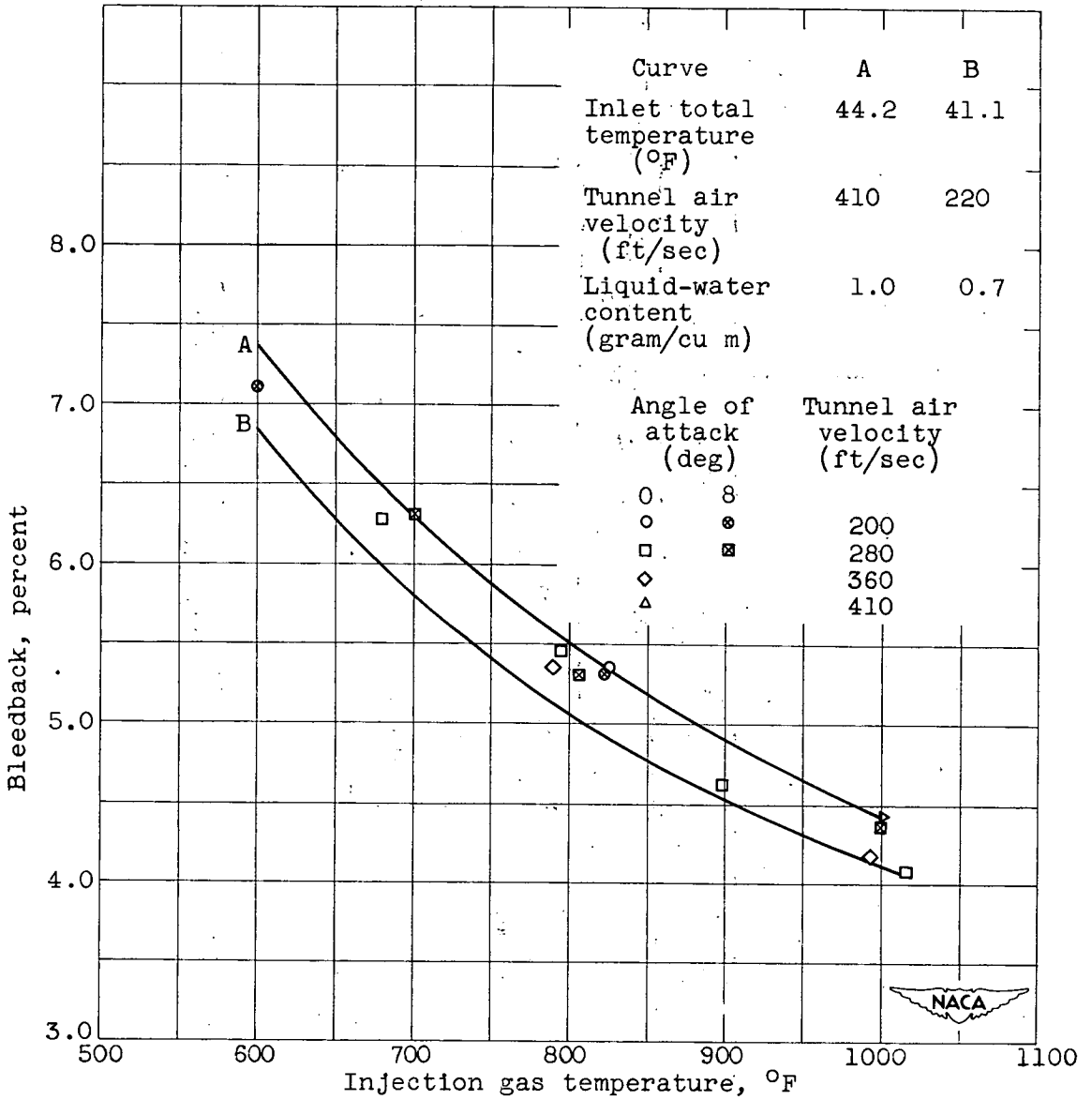

Figure 30. - Bleedback required for ice prevention as a function of injection gas temperature for free-stream total temperature of 0° F.

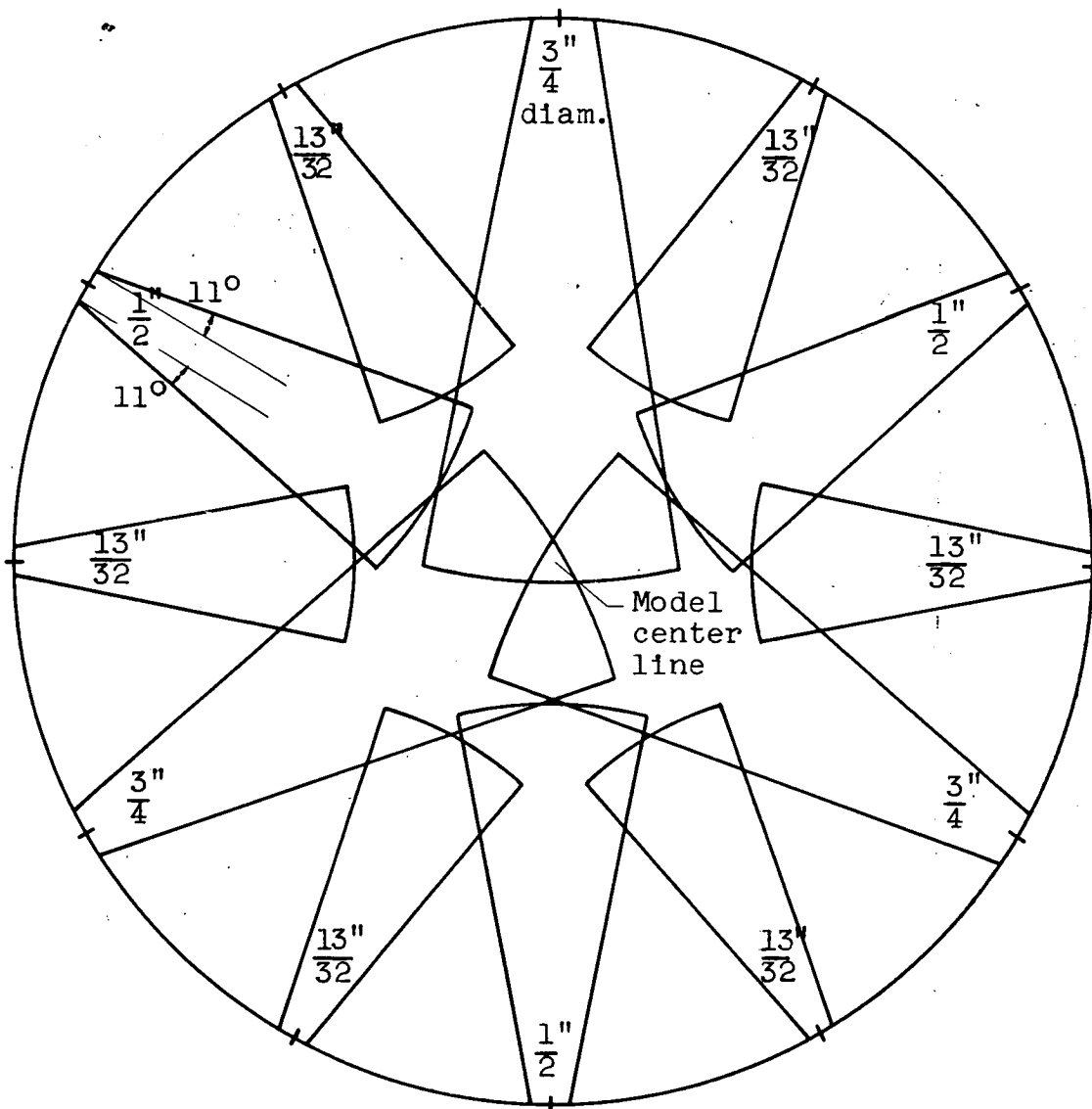

Figure 31. - Sketch showing optimum orifice configuration with calculated jet outlines. Duct diameter, 12.375 inches.



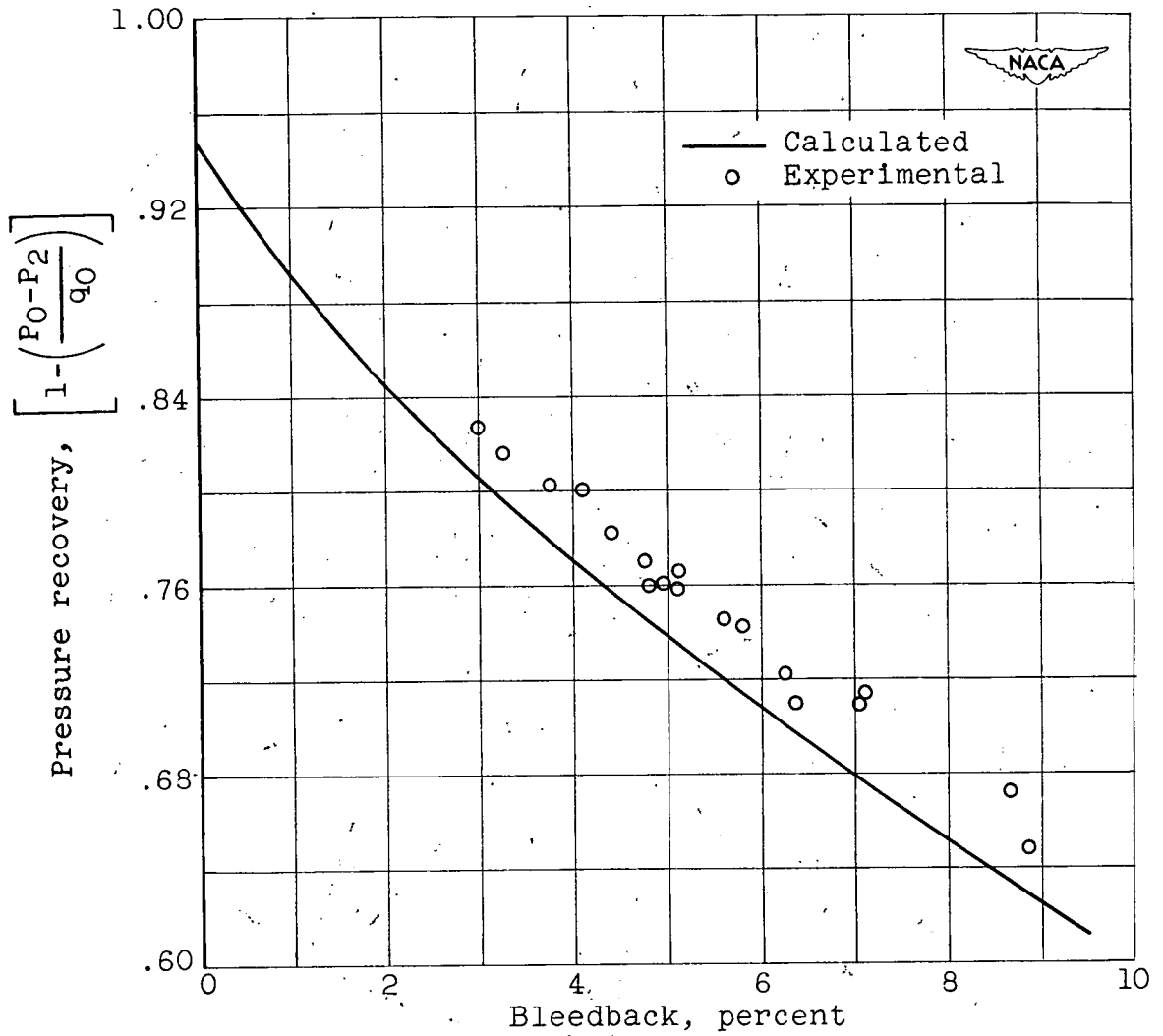

Figure 32. - Pressure recovery as function of bleedback for injection gas temperature of  $1000^{\circ}$  F and a free-stream total temperature of  $0^{\circ}$  F.

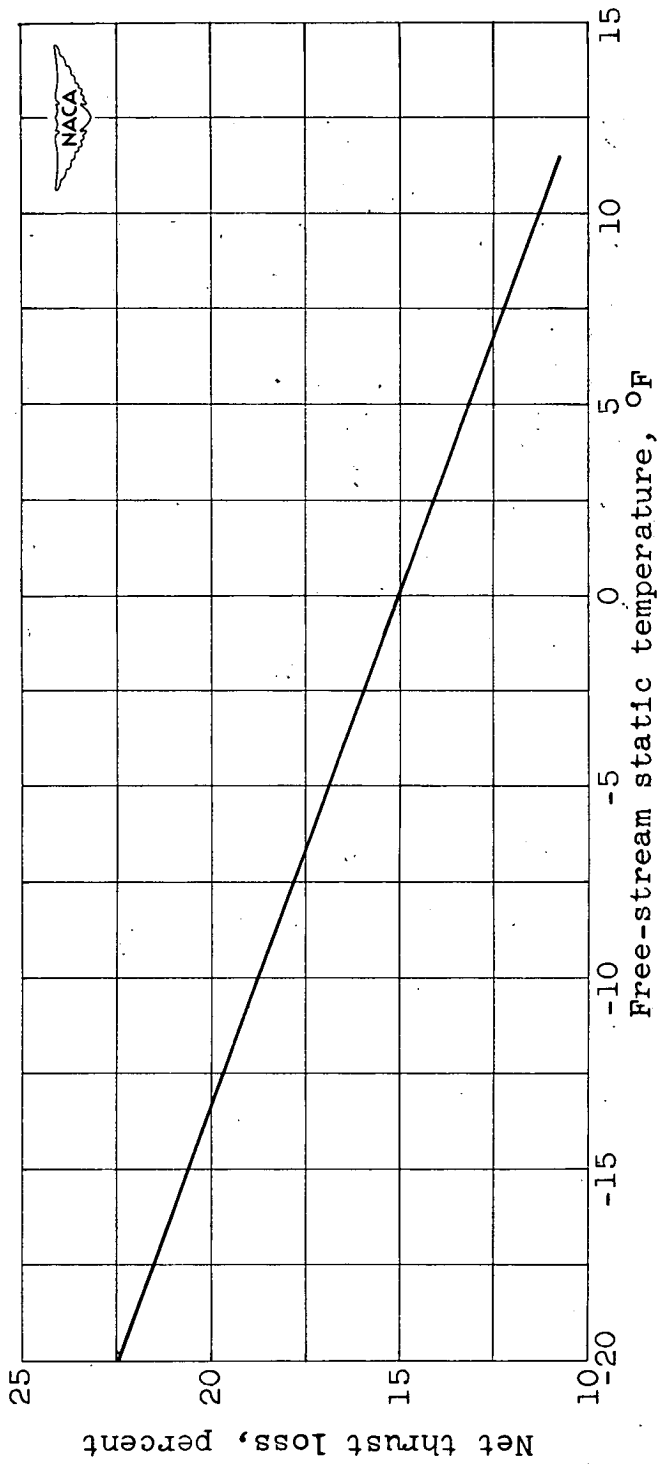

Figure 33. - Thrust loss with hot-gas bleedback to inlet air as function of free-stream static temperature. Flight Mach number, 0.5; liquid-water content, 1.0 gram per cubic meter; pressure altitude, 10,000 feet.

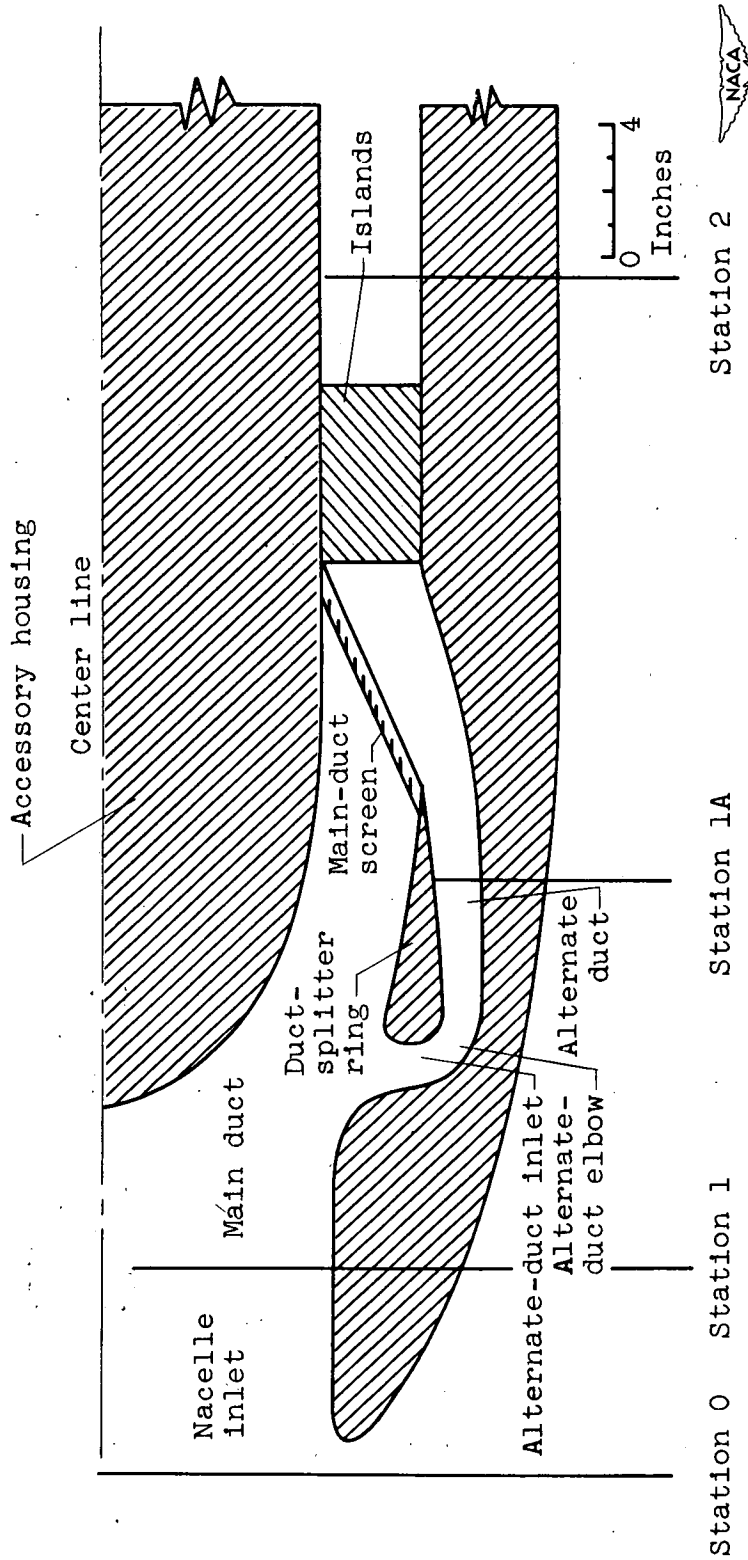

Figure 34. - Sketch of internal inertia-separation inlet showing principal components.

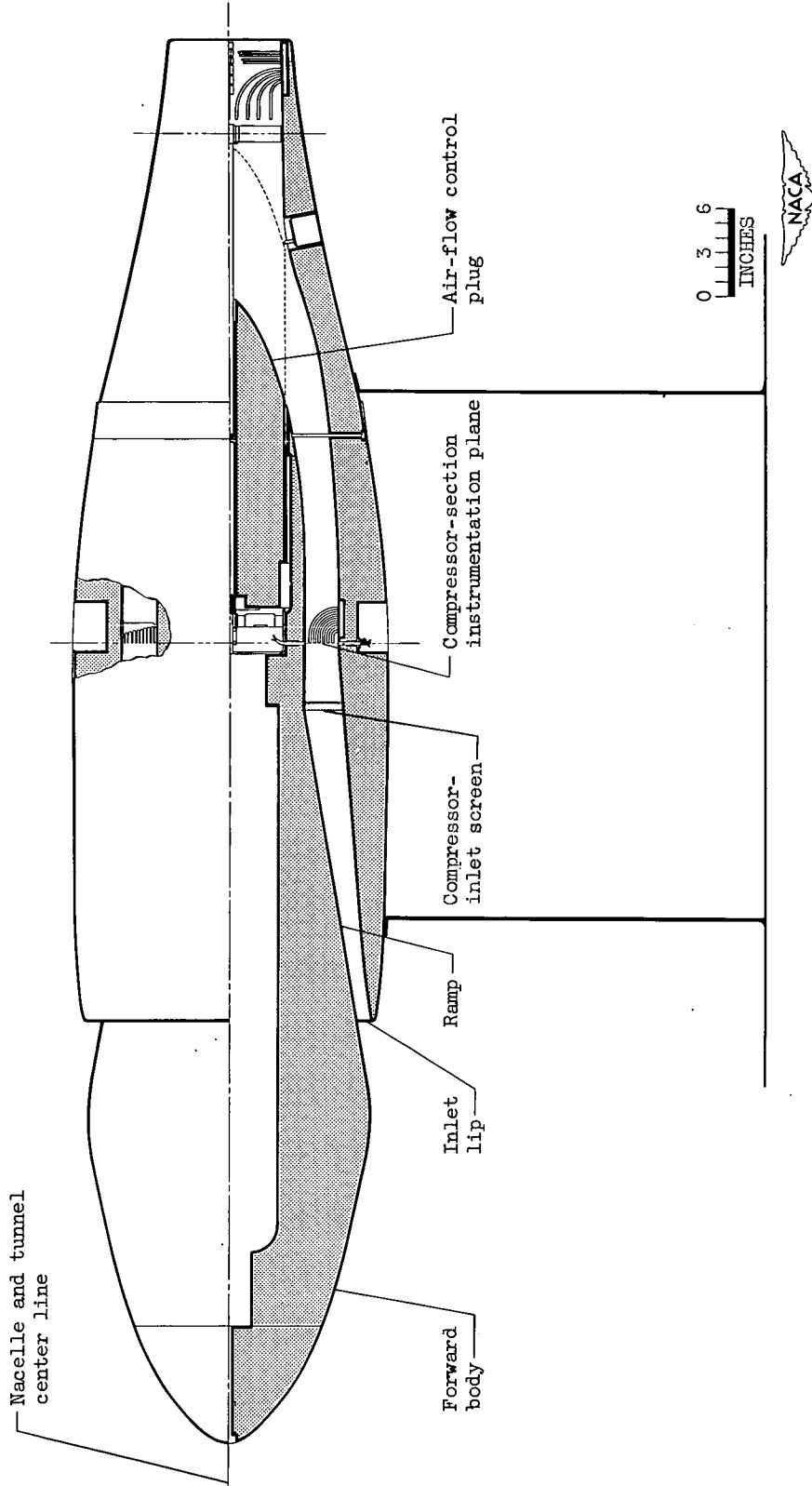
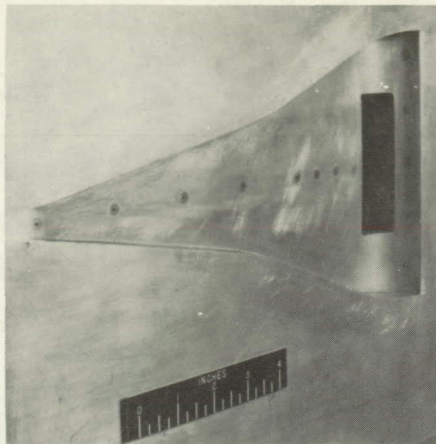

Figure 35. - Schematic sketch of annular submerged-inlet setup.

**Page intentionally left blank**

**Page intentionally left blank**



NACA  
C-20988

(a) View of vent inlet before icing.



NACA  
C-22292

(b) Ice accretions on vent inlet after 60-minute icing time. Tunnel air velocity, 235 feet per second; tunnel-air total temperature, 21° F; liquid-water content, 1.1 grams per cubic meter.

Figure 36. - Icing characteristics of a submerged-inlet type fuel vent.