

NACA IN 3104

# NATIONAL ADVISORY COMMITTEE FOR AERONAUTICS

TECHNICAL NOTE 3104

EXPERIMENTAL INVESTIGATION OF SUBLIMATION OF ICE AT  
SUBSONIC AND SUPERSONIC SPEEDS AND ITS  
RELATION TO HEAT TRANSFER

By Willard D. Coles and Robert S. Ruggeri

Lewis Flight Propulsion Laboratory  
Cleveland, Ohio

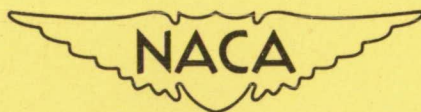

Washington  
March 1954

NATIONAL ADVISORY COMMITTEE FOR AERONAUTICS

TECHNICAL NOTE 3104

EXPERIMENTAL INVESTIGATION OF SUBLIMATION OF ICE AT SUBSONIC AND  
SUPERSONIC SPEEDS AND ITS RELATION TO HEAT TRANSFER

By Willard D. Coles and Robert S. Ruggeri

SUMMARY

An experimental investigation was conducted in a 3.84- by 10-inch tunnel to determine the mass transfer by sublimation, heat transfer, and skin friction for an iced surface on a flat plate for Mach numbers of 0.4, 0.6, and 0.8 and pressure altitudes to 30,000 feet. Measurements of rates of sublimation were also made for a Mach number of 1.3 at a pressure altitude of 30,000 feet.

The results show that the parameters of sublimation and heat transfer were 40 to 50 percent greater for an iced surface than was the bare-plate heat-transfer parameter. For iced surfaces of equivalent roughness, the ratio of sublimation to heat-transfer parameters was found to be 0.90. The sublimation data obtained at a Mach number of 1.3 showed no appreciable deviation from that obtained at subsonic speeds. The data obtained indicate that sublimation as a means of removing ice formations of appreciable thickness is usually too slow to be of much value in the de-icing of aircraft at high altitudes.

INTRODUCTION

Study in the field of icing meteorology has indicated that the greatest probability and frequency of aircraft icing encounters exist at altitudes below 20,000 feet (ref. 1). Modern high-speed, high-altitude aircraft might thus be expected to climb rapidly through icing conditions with subsequent removal of residual ice formations outside the icing conditions. In recent years there has been speculation concerning the possibility of removing these residual ice formations during flight in clear air at high altitudes by the process of sublimation (mass transfer from solid to vapor), thereby minimizing the icing-protection requirements for aircraft. Similarity between the processes of sublimation of ice and evaporation of water makes the principles evolved by previous investigators in the field of evaporation applicable to sublimation studies. From Reynolds analogy and from the work of many

investigators, notably Colburn (refs. 2 and 3), in correlating experimental data, the relations between mass transfer, heat transfer, and skin friction for a flat plate are well known. Thus a reasonably accurate prediction of the rate of sublimation of a smooth ice surface subjected to a tangential low-velocity air stream could be made from available data. However, natural ice formations resulting from the impingement and freezing of small water droplets on a surface are rarely smooth, and very little is known of the sublimation rate of rough ice in a high-velocity air stream.

The present investigation was undertaken to determine the rate of sublimation from the iced surface of a flat plate in a subsonic and a low supersonic air stream, and to relate the sublimation and heat transfer from a rough ice surface. The investigation was conducted in a 3.84- by 10-inch tunnel at the NACA Lewis laboratory.

#### SYMBOLS

The following symbols are used in this report:

$C_f$	average skin-friction coefficient
$c_f$	local skin-friction coefficient
$c_p$	specific heat at constant pressure, Btu/(lb)(°F)
$e$	vapor pressure, in. Hg abs
$g$	acceleration due to gravity, ft/sec <sup>2</sup>
$h_c$	unit thermal convective conductance, Btu/(hr)(sq ft)(°F/ft)
$h_m$	unit mass-transfer conductance, lb/(hr)(sq ft)(lb/lb)
$k$	roughness projection height (ref. 4)
$L_e$	latent heat of evaporation, Btu/lb
$L_s$	latent heat of sublimation, Btu/lb
$M$	Mach number
$m_a$	molecular weight of air
$m_w$	molecular weight of water

- $Pr_h$  Prandtl number for heat transfer
- $Pr_m$  Prandtl number for mass transfer
- $p$  static pressure, in. Hg abs
- $q$  rate of heat transfer per unit area, Btu/(sec)(sq ft)
- $Re$  Reynolds number,  $\rho Ux/g\mu$
- $St_h$  Stanton number of heat transfer,  $\frac{q}{\rho U c_p (t_{ad} - t_s)}$
- $St_s$  Stanton number of sublimation,  $\frac{W}{\rho U \frac{m_w}{m_a} \left( \frac{e_s}{p_1 - e_s} - \frac{e_1}{p_1 - e_1} \right)}$
- $t$  temperature, °F
- $t_{ad}$  adiabatic wall temperature, °F
- $U$  velocity of free stream, ft/sec
- $u$  velocity component in boundary layer parallel to surface, ft/sec
- $W$  sublimation rate, lb/(sec)(sq ft)
- $x$  distance from leading edge of model, ft
- $y$  coordinate normal to surface, ft
- $\gamma$  ratio of specific heats
- $\delta$  boundary-layer thickness, ft
- $\delta^*$  boundary-layer displacement thickness, ft
- $\theta$  boundary-layer momentum thickness, ft
- $\mu$  viscosity of air, (lb)(sec)/sq ft
- $\rho$  weight density of air, lb/cu ft

Subscripts:

- $s$  surface
- $y$  at distance  $y$  above surface

- 0 free stream  
 1 outer edge of boundary layer

### ANALYSIS

The determination of the rate at which ice will sublime from a surface in a high-velocity air stream is dependent primarily on the knowledge of the absolute value of the dimensionless parameter of mass transfer, herein referred to as the Stanton number of sublimation. In order to determine experimental values of the Stanton number of sublimation, the method used in reference 5 for the evaporation of water has been applied to the sublimation process. By this method the temperature of a wet surface in an air stream can be calculated; and if the quantity of matter evaporated can be measured, experimental values of the dimensionless parameter of mass transfer can be determined, provided the relation between the heat transfer and mass transfer from the surface is known. This relation is cited in reference 6 as the Colburn relation and is given as (in the terminology of this report)

$$\frac{h_c}{h_m c_p} = \left( \frac{Pr_m}{Pr_h} \right)^{2/3}$$

The Prandtl number of mass transfer  $Pr_m$  is perhaps better known as the Schmidt number or Taylor number. The Lewis relation also cited in reference 6 is a special case of the Colburn relation in which the ratio of the Prandtl numbers is equal to unity. For the case of water evaporating into air, the value of the preceding relation is nearly equal to unity (refs. 5 and 7) and the ratio of the dimensionless parameters (Stanton numbers) of heat and mass transfer is also nearly equal to unity.

In the treatment of the problem given herein, the equation for the kinetic temperature of a wet surface from reference 5 is used as the starting point. In the notation used herein, this equation has the form

$$t_{ad} - t_s = \frac{St_e}{St_h} \frac{m_w}{m_a} \left( \frac{e_s}{p_1 - e_s} - \frac{e_1}{p_1 - e_1} \right) \frac{L_e}{c_p} \quad (1)$$

Analogy between the processes of evaporation and sublimation makes possible the substitution of the latent heat of sublimation  $L_s$  for the latent heat of evaporation  $L_e$  and the substitution of the Stanton number of sublimation  $St_s$  for the Stanton number of evaporation  $St_e$  in equation (1), which becomes

$$t_{ad} - t_s = \frac{St_s}{St_h} \frac{m_w}{m_a} \left( \frac{e_s}{p_1 - e_s} - \frac{e_1}{p_1 - e_1} \right) \frac{L_s}{c_p} \quad (2)$$

This equation results from combining the equation for the Stanton number of sublimation as defined by

$$St_s = \frac{W}{\rho U \frac{m_w}{m_a} \left( \frac{e_s}{p_1 - e_s} - \frac{e_1}{p_1 - e_1} \right)} \quad (3)$$

with the equation for the Stanton number of heat transfer

$$St_h = \frac{q}{\rho U c_p (t_{ad} - t_s)} \quad (4)$$

where

$$q = L_s W \quad (5)$$

In the determination of values for  $St_s$  from equation (3), the weight rate of sublimation  $W$  is determined experimentally and all the other terms are either known or directly measured except the vapor pressure at the iced surface  $e_s$ . The values of  $e_s$  correspond to the vapor pressure over ice at the surface temperature  $t_s$ . Both  $t_s$  and  $e_s$  may be obtained from equation (2) by a trial-and-error process provided the ratio  $St_s/St_h$  is known. The Stanton number ratio has been related to the two-thirds power of the ratio of Schmidt number to Prandtl number; and as both of these numbers are independent of the initial state (solid or liquid) of the material transferred, there appears to be no reason to differentiate between sublimation from an ice surface and evaporation from a wetted surface.

By means of equations (2), (3), and (4) it is possible to compute values of  $St_h$  and  $St_s$  based on measured values of  $W$  and  $q$ . Because a true measure of  $t_s$ , the temperature of the ice-air interface at which sublimation is taking place, is difficult to obtain, it is necessary to compute its value along with the value of  $e_s$ , the equilibrium vapor pressure over ice corresponding to  $t_s$ . The psychrometric tables relating  $t_s$  and  $e_s$  and the three equations (2), (3), and (4) permit the evaluation of the four unknown quantities  $t_s$ ,  $e_s$ ,  $St_h$ , and  $St_s$ .

Algebraic difficulties require that an iterative process be employed for the evaluation of the four unknowns. This iterative process begins with the use of equation (2) along with the psychrometric tables to compute a first approximation for  $t_s$  and  $e_s$  for a given set of known experimental values of  $t_{ad}$ ,  $p_1$ , and  $e_1$ . In order to make this computation, it is necessary to use a trial value of  $St_s/St_h$ . As a starting point, the value of unity is employed. With  $t_s$  and  $e_s$  computed in this way, values of  $St_s$  are obtained from equation (3) by using the measured values of  $W$  corresponding to the experimental values of  $t_{ad}$ ,  $p_1$ , and  $e_1$ . Experimental values of  $St_h$  which do not depend upon the solution of equation (2) were determined from equation (4) by conducting an investigation which was independent of the sublimation study in a manner such that values of the heat flow  $q$ , and the surface temperature  $t_s$ , could be measured. These computed values of  $St_s$  and  $St_h$  are then used to form a new ratio  $St_s/St_h$  to be used in equation (2) to obtain a second approximation for  $t_s$  and  $e_s$ . New values of  $St_s$  are then computed by means of equation (3). This process is repeated until successive values of the ratio of  $St_s$  and  $St_h$  differ by an amount that is no longer significant in view of the order of accuracy of the experimental measurements.

During the experimental investigation, differences in the ice roughness occurred during the sublimation process. These differences were a function of the Mach number at which the ice was formed. In order to correlate the sublimation Stanton number and the heat-transfer Stanton number and to obtain true values of the ratio of  $St_s/St_h$ , sublimation and heat-transfer data must be obtained at equivalent values of ice roughness. For this purpose and also for the purpose of determining the magnitude of the effect of ice on the skin friction and consequently on the heat-transfer rate, determinations of the skin friction both with and without ice on the surface were made.

In reference 8 the Kármán momentum equation for two-dimensional flow from which local skin-friction coefficients can be calculated is expressed as

$$c_f = \frac{d\theta}{dx} + \theta \left[ \frac{(2 - M_1^2) + \delta^*/\theta}{M_1 \left( 1 + \frac{\gamma-1}{2} M_1^2 \right)} \right] \frac{dM_1}{dx} \quad (6)$$

The momentum thickness  $\theta$  and the displacement thickness  $\delta^*$  are defined by the integrals

$$\theta = \int_0^{\delta} \frac{\rho u}{\rho_1 u_1} \left(1 - \frac{u}{u_1}\right) dy \quad (7)$$

$$\delta^* = \int_0^{\delta} \left(1 - \frac{\rho u}{\rho_1 u_1}\right) dy \quad (8)$$

The average skin-friction coefficient for a surface is the integrated value of the local skin-friction coefficients; thus

$$C_f = \frac{1}{x} \int_0^x c_f dx = \frac{1}{x} \int_0^x \left\{ \frac{d\theta}{dx} + \theta \left[ \frac{(2 - M_1^2) + \delta^*/\theta}{M_1 \left(1 + \frac{\gamma-1}{2} M_1^2\right)} \right] \frac{dM_1}{dx} \right\} dx \quad (9)$$

The second term inside the integral on the right-hand side of equation (9) represents the contribution to the skin-friction coefficient due to the pressure gradient along the model. For the negative pressure gradient which exists in a tunnel of constant cross-sectional area, the pressure-gradient term of equation (9) is positive; hence its inclusion in the calculations would have the effect of increasing the average skin-friction coefficient, especially at the higher Mach numbers ( $dM/dx$  increases with increasing test Mach number). For this investigation the pressure-gradient term was not included because of the difficulty of making the necessary boundary-layer measurements with the equipment used for the sublimation work. With the effect of pressure gradient neglected, equation (9) becomes

$$C_f = \frac{1}{x} \int_0^x \frac{d\theta}{dx} dx = \frac{\theta}{x} = \frac{1}{x} \int_0^{\delta} \frac{\rho_y u_y}{\rho_0 u_0} \left(1 - \frac{u_y}{u_0}\right) dy \quad (10)$$

from which calculations of the average skin-friction coefficient were made.

#### APPARATUS

A schematic diagram of the 3.84- by 10-inch tunnel is presented in figure 1 and shows the inlet diffuser section with screens, the plenum chamber with flow-straightening tubes, the bellmouth tunnel entry, the test section, and the outlet diffuser section. The tunnel is designed to provide a range of subsonic Mach numbers from 0.3 to 0.8 and a supersonic Mach number of 1.3 over the model.



A supply of refrigerated air initially at approximately  $-20^{\circ}$  F and with a specific humidity of  $5.0 \times 10^{-4}$  pounds of water per pound of dry air was conditioned to provide the desired temperatures and humidities at the tunnel test section. The humidity of the air stream was controlled by means of steam injected at a point sufficiently far upstream to ensure thorough mixing at the tunnel entry.

One wall of the tunnel contained a large glass section for observation and visual measurements. The other wall had five portholes for access to the inside of the tunnel and removable plugs for the installation of instrumentation at various stations along the tunnel. Permanent instrumentation of the tunnel at the test section includes static-pressure taps along the top and bottom surfaces of the tunnel and pressure taps and thermocouples in the plenum chamber.

The flat-plate model (fig. 2) used for the study was made of wood to minimize conduction losses. It was 0.75 inch thick, 3.84 inches wide, and 18 inches long. The formation and sublimation of ice took place on a 3.84- by 5.75-inch copper plate set flush in the upper surface of the model with the leading edge of the copper plate located  $4\frac{7}{16}$  inches from the leading edge of the model. The upper surface of the copper plate was instrumented with five thermocouples installed flush with the surface and spaced at  $\frac{1}{8}$ -inch intervals along the center line.

The copper plate, hereinafter referred to as the "cold plate," was the top surface of a multipass copper box through which cold alcohol could be pumped. The alcohol was cooled by pumping it through a coil of copper tubing immersed in an alcohol - dry-ice bath contained in a Dewar flask.

Thermocouples located in the inlet and outlet lines to the copper box were used in conjunction with a potentiometer of high sensitivity to measure the alcohol inlet temperature and alcohol temperature rise between the inlet and outlet lines. It was found that temperature distributions in the inlet and outlet alcohol flow were so great as to preclude the use of any simple thermocouple installation in the tubes. A set of five thermocouples installed in the plane of a cross section of the tubes showed that temperature differences of over  $20^{\circ}$  F existed in the  $\frac{1}{4}$ -inch-diameter tubes. The use of Dewar flasks as plenum chambers close to the model reduced the temperature distribution range in the inlet alcohol flow to less than  $0.5^{\circ}$  F. Because temperature layers were found to exist in the outlet Dewar flask, a glass stirrer was installed in the flask and the temperature of the agitated mixture was measured. In order to check the validity of the use of the agitated-mixture temperature as the temperature at the outlet from the copper box, the direction of alcohol flow was reversed and no measurable

difference between the temperatures as measured in the flask or in the outlet tube was observed. Therefore the temperature loss in the line between the model and the flask was negligible. A pictorial schematic diagram of the alcohol and thermocouple systems is included in figure 2.

Measurement of ice thickness while the tunnel was in operation was possible by the use of a short-focal-length telescope mounted on a vernier carriage.

Boundary-layer total-pressure measurements were made by using a 16-tube rake mounted as illustrated in figure 2. The rake tubes were 0.017 inch in diameter and  $3/8$  inch long from tip to rake body. The tubes were spaced 0.03 inch between centers for the first  $1/4$  inch above the model and 0.04 inch between centers for the remainder of the rake.

#### PROCEDURE

The study of sublimation and heat transfer from an iced surface requires that the ice surface and the physical characteristics of the ice be readily reproducible, and for this investigation it was desired that the ice approximate that formed on aircraft surfaces. Preliminary experimentation with several methods of forming ice together with limitations of space and access to the inside of the tunnel indicated that ice formed by the condensation of moisture from a humidity-controlled air stream on the cold surface of a metal plate most nearly suited the requirements.

The study of the heat-transfer process from the iced surface imposes two additional requirements: (1) the transfer of heat must take place without the transfer of mass to avoid interaction of the two processes, and (2) the measurement of the temperature of the ice surface should be possible. The condensation method of forming the ice offers an indirect method for obtaining the surface temperature by measurement of the humidity of the air stream under conditions for which the ice thickness is constant (no net condensation or sublimation effect). The ice surface temperature under these conditions is equal to the temperature of saturation of the air stream. Thus both the additional requirements of the heat-transfer study can be satisfied through use of the condensation method of forming the ice. Therefore for this investigation ice was caused to form on the cold plate by increasing the humidity of the air stream by means of steam injection. When the dew point of the air stream exceeded the surface temperature of the cold plate, condensation in the form of a dense frost-like ice formation occurred, as shown in figure 3.

The movable probe shown in figure 3 was used for purposes of focusing the telescope and aiding in the determination of ice thickness. Throughout the investigation, each ice formation was deposited on the refrigerated surface of the cold plate at nearly constant values of 5000-foot pressure altitude and 45° F total temperature of the air stream in order to assure reproducibility of ice formations for the different altitude conditions at each Mach number. During the sublimation study when the desired ice thickness was attained, the ice formation was caused to sublime by reducing the humidity of the air stream. At the time the humidity of the air was lowered, the desired sublimation altitude was set, the alcohol was drained from the copper box to minimize the heat-sink effect, and the total temperature of the air stream was reduced to an arbitrary subfreezing temperature (27° F). The sublimation of the ice was in some cases complete in as short a period of time as 9 minutes; therefore it was impractical, from the standpoint of the time required, to lower the temperature of the air stream to values of total temperature corresponding to each Mach number and altitude condition. The temperature of 27° F was selected because it was readily obtained and required approximately the same period of time to be established for each of the sublimation conditions.

Sublimation rates were obtained at Mach numbers of 0.4, 0.6, and 0.8 for pressure-altitude conditions of 5000, 15,000, and 30,000 feet. Because of test-facility limitations, the Mach number condition of 1.3 was investigated at a pressure altitude of 30,000 feet only. In order to obtain measurements of ice density, a 2- by 4-inch sheet of brass 0.002 inch thick was wetted on one side and frozen to the copper cold plate. Ice was formed on the thin brass sheet by condensation, the ice thickness was measured, and then the brass sheet and the ice were lifted from the cold plate and the ice weight and density were determined. The ice density was assumed to be uniform throughout its thickness and at all points on the surface. The rates of sublimation were determined from ice-density measurements and plots of ice thickness against time. The slope of the secant on the plot of ice thickness against time during the interval from 2 minutes after sublimation started to the time when sublimation had caused any small portion of the cold plate to become bare of ice was taken as the rate of change of ice thickness with time. The initial 2-minute interval was allowed for stabilization of the temperature conditions of the copper box.

For the heat-transfer study, ice was caused to form on the cold plate under the subsonic Mach number and pressure-altitude conditions as previously stated in this section for the sublimation study. After the desired thickness of ice had been formed on the cold plate (approximately 0.2 cm), the humidity of the air stream was reduced to the condition under which the ice thickness remained constant, indicating that the sublimation of the ice and the condensation of the vapor on the ice surface were taking place at the same rate, and that the temperature of

the ice surface was the temperature of the frost point of the air stream. The frost-point temperature was measured from continuous samples of the air taken from the tunnel plenum chamber and expanded to correspond to the static pressure existing at the cold plate. A sensitive dew-point meter was used for these measurements. In order to provide a basis of comparison with previous investigators and for the purpose of determining the effect that ice on a surface has on the heat-transfer rate, data were also obtained for the model with no ice on the surface for a similar range of conditions.

The heat transferred through the ice or to the bare surface was determined from the heat gained by the alcohol flowing through the copper box in the model, as obtained from measurement of alcohol flow rate and change in alcohol temperature. The alcohol flow rate was measured by diverting the flow by means of the three-way valve shown in figure 2 and by obtaining volume measurements of the alcohol over a period of 45 seconds. The heat gained by the alcohol includes that transferred by conduction through the model, which must be subtracted from the total to determine the heat gained by convection only. By covering the cold plate with a good insulating material of known conductivity, the heat gain through this insulating material could be determined and subtracted from the total for the insulated model, which leaves the heat gained by conduction through the wood. A cork insulator was cemented to the cold-plate surface; and the heat gained by conduction through the wood was determined for the various Mach numbers, pressure altitudes, and alcohol bulk temperatures. The heat gained by conduction through the cork was computed from average plate surface temperature measurements beneath the cork and the adiabatic wall temperature for the stream side of the cork together with a value of the conductivity of corkboard from reference 9. The use of the adiabatic wall temperature as the surface temperature of the cork during heat transfer through the cork results in an error of the order of 5.0 percent of the heat flow through the cork. However, because the heat conducted through the cork is a relatively small proportion of the total heat gained by conduction, the resulting error in the conduction heat-transfer rate is approximately 1.0 percent. Subtraction of the heat gain through the cork from the total heat gain gave values for the heat gained by conduction through the wood, from which a conduction correction factor was determined. This correction factor is a function of Reynolds number, as the heat conducted through the wood was first transferred to the wood by convection from the air stream. The values of the heat gained by conduction were obtained by using the conduction correction factors and these values were subtracted from the total heat gain measured with the surface bare or iced to determine the convective heat transfer to the plate surface.

Average skin-friction coefficients for the model both with and without ice on the surface were determined from pressure-rake data for the subsonic Mach number and pressure-altitude conditions.

Mass-transfer, heat-transfer, and skin-friction data are generally presented as a function of Reynolds number. In the calculation of Reynolds number for this investigation, the characteristic length used was the length from the leading edge of the model to the point where the various measurements were taken. In the case of the sublimation experiments, the point at which ice thickness was observed with the telescope was used and was approximately 1 inch downstream of the center of the copper cold plate. The heat-transfer Reynolds numbers were based on the length from the leading edge to the center of the cold plate as the heat-transfer determination was the average for the entire cold plate. The length from the leading edge of the wood plate to the tip of the pressure rake (approximately 1/2 inch downstream of the trailing edge of the cold plate) was used for the characteristic length for the friction-coefficient data. Density, viscosity, and Reynolds numbers were based on the arithmetic mean of the plate or ice surface temperature and the free-stream static temperature.

#### RESULTS AND DISCUSSION

During the process of sublimation of ice in an air stream, the heat required to cause the change of state from ice to vapor is transferred to the ice from the air stream. Thus the processes of heat transfer and mass transfer are interrelated during sublimation. Experimental values of the rate of sublimation from an ice surface are used in this investigation in conjunction with experimental values of the rate of heat transfer from an iced surface under conditions for which there was no transfer of mass to determine values of the Stanton number of sublimation and the ratio of the Stanton number of sublimation to the Stanton number of heat transfer.

Visual observations of the ice surface indicated differences in the ice roughness as a function of (1) the Mach number at which the ice was formed, (2) the pressure altitude and Mach number at which sublimation took place, and (3) the time interval from start of sublimation. The ice formed at the higher Mach numbers was observed to be smoother than that formed at the lower Mach number conditions. During the sublimation process, local areas of the ice surface sublimated more rapidly than other areas, resulting in a "dished" appearance of the surface; however, smoothing out of the individual small projections did occur. The dishing effect was particularly severe at the higher-static-pressure (low altitude) and low Mach number conditions. At the high-altitude condition and particularly at high Mach numbers, the ice became smoother during sublimation than it was at the start of sublimation. Since constant ice thickness was maintained during the heat-transfer study, the ice was not subjected to the effects of sublimation on ice-surface roughness.

Because of the differences in the ice roughness which existed, a strict comparison of the sublimation and heat-transfer results is possible only for surface conditions of equivalent roughness.

### Skin-Friction Coefficients

In order to determine points of equivalent roughness, a study of the skin friction at subsonic Mach numbers was made for the sublimation and heat-transfer conditions used in this investigation. The study also included the determination of skin friction for the bare plate for the purpose of evaluating the effect of the ice formations on heat transfer and skin friction. The results of the skin-friction studies are presented in figure 4 for the bare plate and for the iced plate during the sublimation process.

The skin-friction data are an average, as equation (10) has the length from the leading edge of the model to the pressure rake as a divisor. Thus the skin-friction results are average values existing over the model at the instant the data were recorded. The contribution to the skin-friction coefficient of that part of the model ahead of the cold plate is constant for a given set of Mach number and altitude conditions. Therefore a direct comparison may be made of the skin-friction coefficients obtained with ice on the surface and with the bare plate to determine the effect of the ice formation on skin friction.

The average skin-friction coefficients obtained by the equation of Schoenherr (ref. 4) for a smooth plate and by Baines (ref. 4) for a rough surface are presented for comparison. The curve of Baines presented in figure 4 is for  $x/k = 1500$ , where  $k$  is the roughness projection height and  $x$  is the surface distance measured from the leading edge. The slope and general shape of the data curves are comparable with the curves of Schoenherr and Baines. The effect of Mach number, sublimation time, and pressure altitude (higher Reynolds numbers corresponding to low altitudes) on the roughness of the ice formation and consequently on the skin-friction coefficient is indicated. The change in average skin-friction coefficient during sublimation is shown in figure 4 for the 0.4 and 0.8 Mach number conditions. The upper dashed curve for each Mach number shows the skin-friction coefficient shortly after the sublimation process started, and the lower solid curves show the skin-friction coefficient after sublimation had progressed for several minutes. The values of average skin-friction coefficient show negligible change with time at the higher Reynolds numbers for each Mach number and appreciable reduction at the low Reynolds numbers, demonstrating the smoothing effect of sublimation at high altitude on ice roughness.

In figure 5 is shown the variation of average skin friction with Reynolds number obtained with ice of constant thickness (sublimation

and condensation occurring at the same rate) on the plate for two Mach number conditions. The process of regulating the humidity of the air stream to cause the frost point to correspond to the surface temperature required a considerable period of time, particularly as the frost point approached the surface temperature value. Thus the ice formation was subjected to relatively long periods of very slow sublimation or condensation, which had the effect of reducing the original ice roughness. This effect is reflected in the generally lower values of average skin-friction coefficient in figure 5 than are shown in figure 4.

As has been previously noted in the ANALYSIS section, the inclusion of the pressure-gradient term in the calculations of average skin-friction coefficient would have the effect of increasing the average skin-friction coefficient, especially at the higher Mach numbers. Thus the curves of skin-friction coefficient in figures 4 and 5 would be raised for both the bare- and iced-plate conditions. The bare-plate data would be in closer agreement with the Schoenherr line, and the sublimation skin-friction data (fig. 4) would be brought closer together with the 0.6 and 0.8 Mach number lines being raised more than the 0.4 Mach number line. In like manner, the curves of skin-friction coefficient in figure 5 would be increased, especially at the higher Reynolds numbers, and the constant Mach number lines would be brought closer together. Thus the variation of skin-friction coefficient of the iced surface with Mach number would be reduced over that shown in the figure.

Previous measurements (unpublished data) on a dimensionally similar flat plate show that the contribution to the local skin-friction coefficient by the pressure-gradient term is of the order of 10 percent for the 0.4 Mach number condition and as much as 30 percent at a Mach number of 0.8. Application of this type of correction to the data of figures 4 and 5 cannot be justified because of the lack of boundary-layer data with ice on the plate.

#### Stanton Numbers of Sublimation and Heat Transfer

The sublimation data obtained in this investigation were first calculated by using a value of unity for the ratio  $St_s/St_h$ . Values of  $St_s$  were obtained from equations (2) and (3). The heat-transfer data were calculated by using equation (4) to determine  $St_h$ . The ratio of the Stanton numbers thus determined from the experimental data had a value of 0.94. Recalculation of the data was then made by using an assumed value of 0.90 for the ratio  $St_s/St_h$  with a consequent reduction in the values of  $St_s$ . The experimental Stanton number ratio was then found to be approximately 0.90, which agrees with the assumed value. This determination of Stanton number ratio was made over the Mach number range of 0.4 to 0.8 and a pressure-altitude range of 5000 to 30,000 feet because both these factors influence the ice roughness.

The sublimation data obtained with the value of 0.90 for  $St_s/St_h$  are presented in figure 6 in the form of the Stanton number of sublimation as a function of Reynolds number. The solid faired line was obtained by use of the method of least squares. The heat-transfer Stanton number, as a function of Reynolds number, calculated for the case of a smooth flat plate from an empirical equation given in reference 10 is included for comparison. The data show that the Stanton number of sublimation  $St_s$  decreases with increasing Reynolds number and has a slope very nearly equal to that of the empirical relation for the heat transfer from a smooth plate. No consistent tendency to deviate from the subsonic results is exhibited by the limited data obtained at a Mach number of 1.3.

Roughness trends as a function of Mach number in the sublimation data, which might be expected from the skin-friction results, are not apparent in figure 6, probably because of the time-period average factor in the determinations of the Stanton numbers (roughness changes during the period masking the original roughness differences). Another possible explanation is that the effect of any ice roughness is of such magnitude that changes in the roughness have little effect on sublimation rate.

In figure 7 is shown the variation of the Stanton number of heat transfer  $St_h$  as a function of Reynolds number for the model both with and without ice on the surface of the cold plate. As has been previously mentioned in the ANALYSIS section, the values of  $St_h$  do not depend on assumed values of the Stanton number ratio or the solution of equation (2). The empirical relation for the Stanton number of heat transfer as a function of Reynolds number for a smooth flat plate (ref. 10) is again included for comparison. The bare-plate data show very good agreement with the empirical relation of reference 10. The faired line for the iced-plate data was obtained by the method of least squares. Here, as was the case with  $St_s$ , no Mach number trend was found. Comparison of figures 6 and 7 both with and without ice on the surface of the plate shows that, for ice roughness of the order of that present during this investigation, the sublimation and heat-transfer Stanton numbers are 40 to 50 percent higher than those for a smooth plate. The increase in heat-transfer Stanton numbers due to ice on the surface was comparable with the increase in average skin-friction coefficients caused by ice on the surface. In order to determine points of equivalent roughness for which true values of the ratio  $St_s/St_h$  may be obtained, a plot of the skin-friction against Reynolds number data presented in figures 4 and 5 was made as shown in figure 8. These data correspond to the condition for which the sublimation and heat-transfer data of figures 6 and 7 were obtained. At the point of intersection of each of the pairs of constant Mach number lines, the skin-friction coefficient for the two cases is equal and consequently the point of intersection corresponds to a point of equivalent roughness. Comparing the value of  $St_s$  to



that of  $St_h$  at the Reynolds numbers corresponding to these two points of equal roughness results in values of the ratio  $St_s/St_h$  of 0.895 and 0.902 for the 0.6 and 0.8 Mach number data, respectively. The average value of the experimentally determined ratio  $St_s/St_h$  is thus approximately 0.90, which is in agreement with the value assumed for the calculations. Since the values of  $St_s$  and  $St_h$  of figures 6 and 7 are not influenced in any consistent manner by the differences in ice roughness which were shown to exist by the skin-friction results, a direct comparison of the Stanton numbers may be justified over the entire Reynolds number range. This ratio of the Stanton numbers is presented in figure 9 and has an average value over the entire Reynolds number range of approximately 0.90, as was found for the two points of equivalent roughness.

#### Application to Aircraft Icing

Sublimation of an ice formation from an aircraft surface occurs during flight in clear air even though the air may be saturated. The relatively high surface temperatures of the ice (brought about by the frictional heating associated with high-speed flight) raise the vapor pressure at the surface of the ice such that it is always greater than the vapor pressure of the ambient air. Curves showing the sublimation rate as a function of altitude and of air velocity over the iced surfaces for two ambient-air temperatures at each of three altitudes are shown in figure 10. The value of 0.90 for the Stanton number ratio was used in the computations for these curves. The curves for flight in saturated air are shown in figure 10(a) and for flight in dry air in figure 10(b). A sample problem illustrating the method of calculation and the use of the curves of figure 10 is presented in the appendix.

A comparison of the curves presented in figure 10 shows that the rate of sublimation is somewhat greater for flight in dry air than for flight in saturated air, especially for the lower-altitude conditions. For example, for a velocity of 550 miles per hour at a pressure altitude of 20,000 feet and an air temperature of  $-15^\circ$  F, the rate of sublimation in dry air is approximately 15 percent greater than that in saturated air; whereas for the 30,000-foot condition at  $-40^\circ$  F the increase is only approximately 8.5 percent. The decreased difference for the 30,000-foot condition results from the very low vapor pressures which accompany the low temperatures at high altitudes. Figure 10 shows that sublimation at high altitudes is too slow to be of much value in de-icing of aircraft of the transport type which may accumulate ice formations of appreciable thickness.

The dashed curves are presented to show the effect of Reynolds number on the rate of sublimation. These curves show that, for the same air velocity over the iced surface, sublimation will take place more

rapidly nearer the leading edge than at a point some distance back on the body. The curves are applicable, however, only for turbulent flow over the iced surface.

The curves presented in figure 10 do not necessarily represent the maximum sublimation rates which might be experienced in flight. An extremely rough ice surface might be expected to yield rates of sublimation greater than those presented in the figure.

#### SUMMARY OF RESULTS

The experimental investigation to determine the mass transfer by sublimation, heat transfer, and skin friction for an iced flat surface yielded the following results:

1. The Stanton numbers of sublimation and heat transfer were 40 to 50 percent higher for an iced surface than the Stanton number of heat transfer for a bare plate.

2. For iced surfaces of equivalent roughness, the ratio of the Stanton numbers of sublimation and heat transfer was 0.90.

3. Average skin-friction coefficients obtained with iced surfaces and with a bare plate showed increases due to ice roughness comparable with the increase in heat-transfer Stanton number due to ice on the surface.

4. The data obtained at a Mach number of 1.3 showed no appreciable deviation in sublimation Stanton number from that obtained at subsonic speeds.

5. Sublimation as a means of removing an ice formation of appreciable thickness is usually too slow to be of much value in aircraft de-icing at high altitudes.

Lewis Flight Propulsion Laboratory  
National Advisory Committee for Aeronautics  
Cleveland, Ohio, November 18, 1953

## APPENDIX - SAMPLE CALCULATIONS

The effectiveness of sublimation as a means of removing an ice formation is illustrated by the following numerical example:

Given conditions:

Altitude, ft . . . . .	30,000
Pressure, in. Hg abs . . . . .	8.89
Ambient air temperature, °F . . . . .	-40
Air velocity over iced surface, ft/sec . . . . .	805
Mach number . . . . .	0.8
Ice deposit, in. . . . .	0.2
Ice specific gravity . . . . .	0.8
Ice density, lb/cu ft . . . . .	49.9
Distance from leading edge, ft . . . . .	1
Humidity, at ambient air temperature . . . . .	saturated
Latent heat of sublimation, Btu/lb . . . . .	1220
Specific heat of air, Btu/(lb)(°F) . . . . .	0.24
Ratio of molecular weight of water to molecular weight of air. . . . .	.0.622

Problem: To determine the time required to remove the ice by sublimation.

Equation (2) is used to determine the surface temperature and surface vapor pressure of the ice, and equation (3) is used to determine the weight rate of sublimation. The value of 0.90 will be used for the ratio  $St_s/St_h$ , and the value of  $St_s$  is taken from figure 6.

Equation (2) may be restated as

$$t_s = t_{ad} - \frac{St_s}{St_h} \frac{m_w}{m_a} \left( \frac{e_s}{p_1 - e_s} - \frac{e_1}{p_1 - e_1} \right) \frac{L_s}{c_p} \quad (2)$$

The adiabatic wall temperature  $t_{ad}$  is obtained from the equation

$$t_{ad} = t_0(1 + 0.176M^2)$$

where  $t_{ad}$  and  $t_0$  are in °R. Thus  $t_{ad} = 467.3^\circ R$  or  $7.3^\circ F$ . The saturated vapor pressure at the ambient temperature is 0.0039 inch mercury from reference 11. Substitution of the known values into the equation for determining surface temperature results in the following equation:

$$t_s = 7.3 - 0.90 \times 0.622 \times \frac{1220}{0.24} \left( \frac{e_s}{8.89 - e_s} - \frac{0.0039}{8.89 - 0.0039} \right)$$

By assuming values of  $t_s$  and corresponding values of  $e_s$  from reference 11 and solving by trial-and-error procedure, the value of  $t_s$  is found to be  $-2.3^\circ$  F with a corresponding value of  $e_s = 0.0338$  inch mercury. The quantity  $\left( \frac{e_s}{p_1 - e_s} - \frac{e_1}{p_1 - e_1} \right)$  has a value of 0.003378.

The temperature which is used in determining the air viscosity, air density, and Reynolds number is the arithmetic mean of the ambient air temperature and the surface temperature; or  $(t_0 + t_s)/2 = -21.2^\circ$  F.

The air density is found to be 0.0269 pound per cubic foot and the Reynolds number at a point 1 foot from the leading edge is  $2.066 \times 10^6$ . From figure 6 the value of  $St_s$  is found to be  $2.46 \times 10^{-3}$ .

Equation (3) solved for the weight rate of sublimation becomes

$$W = St_s \rho U \frac{m_w}{m_a} \left( \frac{e_s}{p_1 - e_s} - \frac{e_1}{p_1 - e_1} \right)$$

Substituting values gives

$$\begin{aligned} W &= 2.46 \times 10^{-3} \times 0.0269 \times 805 \times 0.622 \times 0.003378 \\ &= 0.000112 \text{ lb}/(\text{sec})(\text{sq ft}) \\ &= 0.403 \text{ lb}/(\text{hr})(\text{sq ft}) \end{aligned}$$

The weight of ice to be removed from each square foot of surface is

$$\begin{aligned} \text{Ice weight} &= 0.20/12 \text{ ft} \times 1 \text{ sq ft} \times 49.9 \text{ lb ice}/\text{cu ft} \\ &= 0.832 \text{ lb} \end{aligned}$$

The time for removing the ice by sublimation is thus

$$\frac{0.832 \text{ lb}/\text{sq ft}}{0.403 \text{ lb}/(\text{hr})(\text{sq ft})} = 2.06 \text{ hr}$$

The solution of a problem with conditions within the range of figure 10 may be readily obtained as demonstrated by using the conditions of the example. For a velocity over the iced surface of 805 feet per second (549 mph), the rate of sublimation given by figure 10(a) is again 0.403 pound per hour per square foot.

For the case where sublimation takes place in completely dry air, figure 10(b) yields a sublimation rate of 0.432 pound per hour per square foot; and the time for removal is 1.93 hours.

If atmospheric conditions were such that the ice formation in the preceding example could be sublimated at an altitude of 20,000 feet and at an air temperature of  $-5^{\circ}$  F, the sublimation rate as found from figure 10(a) for saturated air is 1.103 pounds per hour per square foot and the removal time is approximately 45 minutes.

#### REFERENCES

1. Hacker, Paul T., and Dorsch, Robert G.: Summary of Meteorological Conditions Associated with Aircraft Icing and Proposed Method of Selecting Design Criteria for Ice-Protection Equipment. NACA TN 2569, 1951.
2. Colburn, Allan P.: A Method of Correlating Forced Convection Heat Transfer Data and a Comparison with Fluid Friction. Trans. Am. Inst. Chem. Eng., vol. XXIX, 1933, pp. 174-210.
3. Chilton, T. H., and Colburn, A. P.: Mass Transfer (Absorption) Coefficients. Ind. and Eng. Chem., vol. 26, no. 11, Nov. 1934, pp. 1183-1187.
4. Baines, W. D.: A Literature Survey of Boundary-Layer Development on Smooth and Rough Surfaces at Zero Pressure Gradient. Iowa Inst. Hydraulic Res., Univ. Iowa, 1951. (Office Naval Res. Contract N8-onr-500.)
5. Hardy, J. K.: Kinetic Temperature of Wet Surfaces - A Method of Calculating the Amount of Alcohol Required to Prevent Ice, and the Derivation of the Psychrometric Equation. NACA WR A-8, 1945. (Supersedes NACA ARR 5G13.)
6. Boelter, L. M. K., Cherry, V. H., Johnson, H. A., and Martinelli, R. C.: Heat Transfer Notes. Univ. Calif. Press (Berkeley), 1946, p. XVI-36.
7. Callaghan, Edmund E.: Analogy Between Mass and Heat Transfer with Turbulent Flow. NACA TN 3045, 1953.
8. Tucker, Maurice: Approximate Turbulent Boundary-Layer Development in Plane Compressible Flow Along Thermally Insulated Surfaces with Application to Supersonic-Tunnel Contour Correction. NACA TN 2045, 1950.
9. McAdams, William H.: Heat Transmission. Second ed., McGraw-Hill Book Co., Inc., 1942, p. 383.

10. Eckert, E. R. G.: Introduction to the Transfer of Heat and Mass.  
First ed., McGraw-Hill Book Co., Inc., 1950, p. 117.
11. Marvin, C. F.: Psychrometric Tables for Obtaining the Vapor  
Pressure, Relative Humidity, and Temperature of the Dew Point.  
W.B. No. 235, Weather Bur., U.S. Dept. Commerce, 1941.

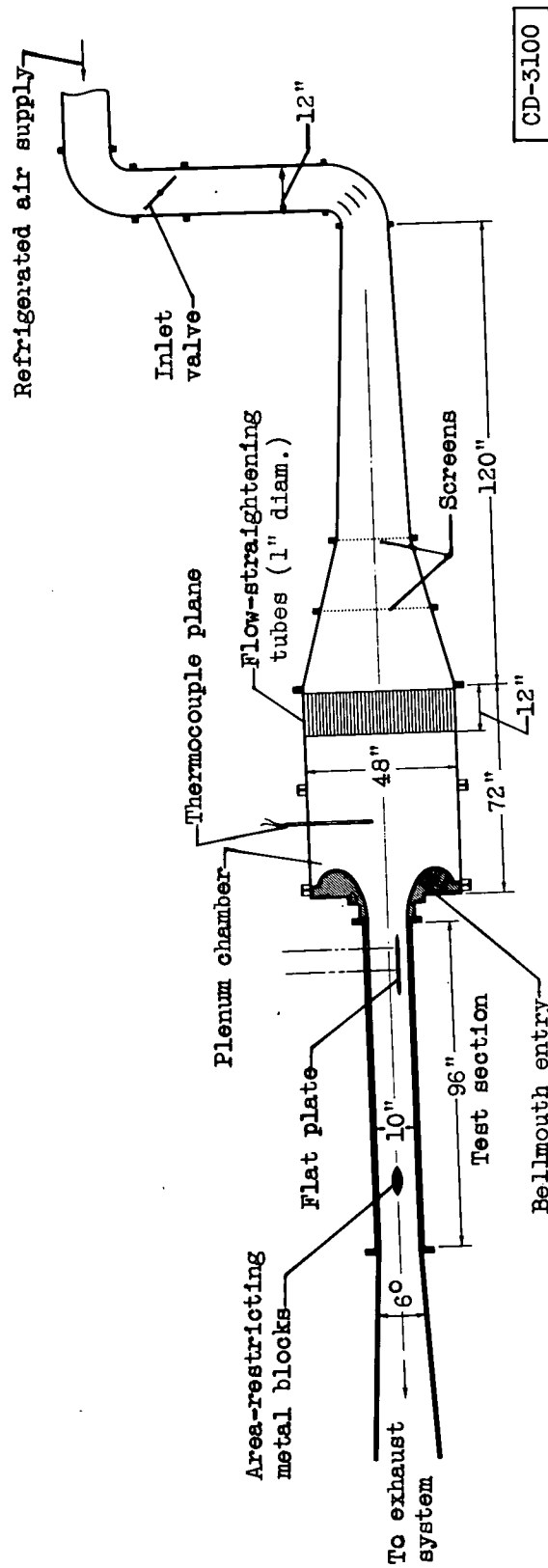

Figure 1. - Schematic diagram of 3.84- by 10-inch tunnel.

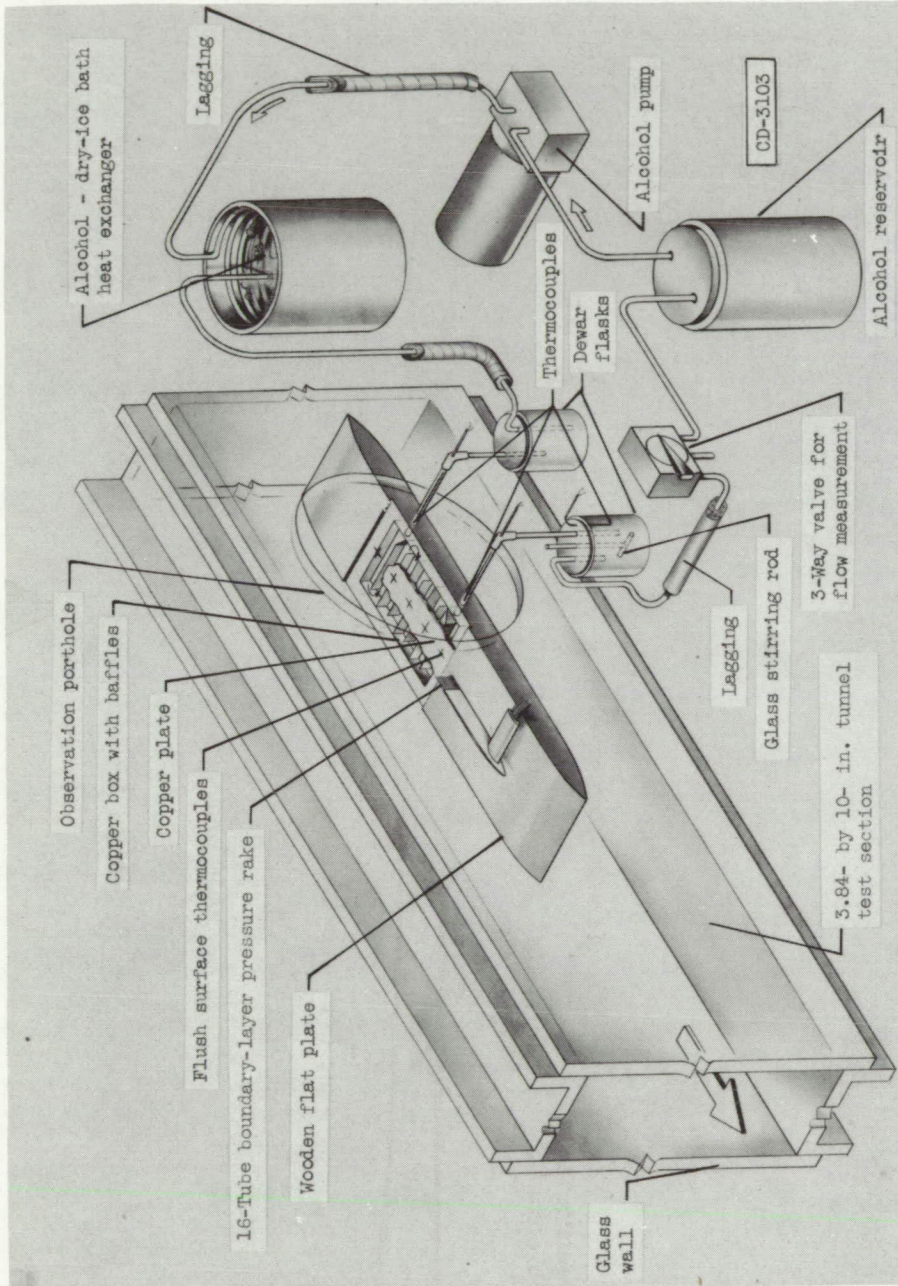
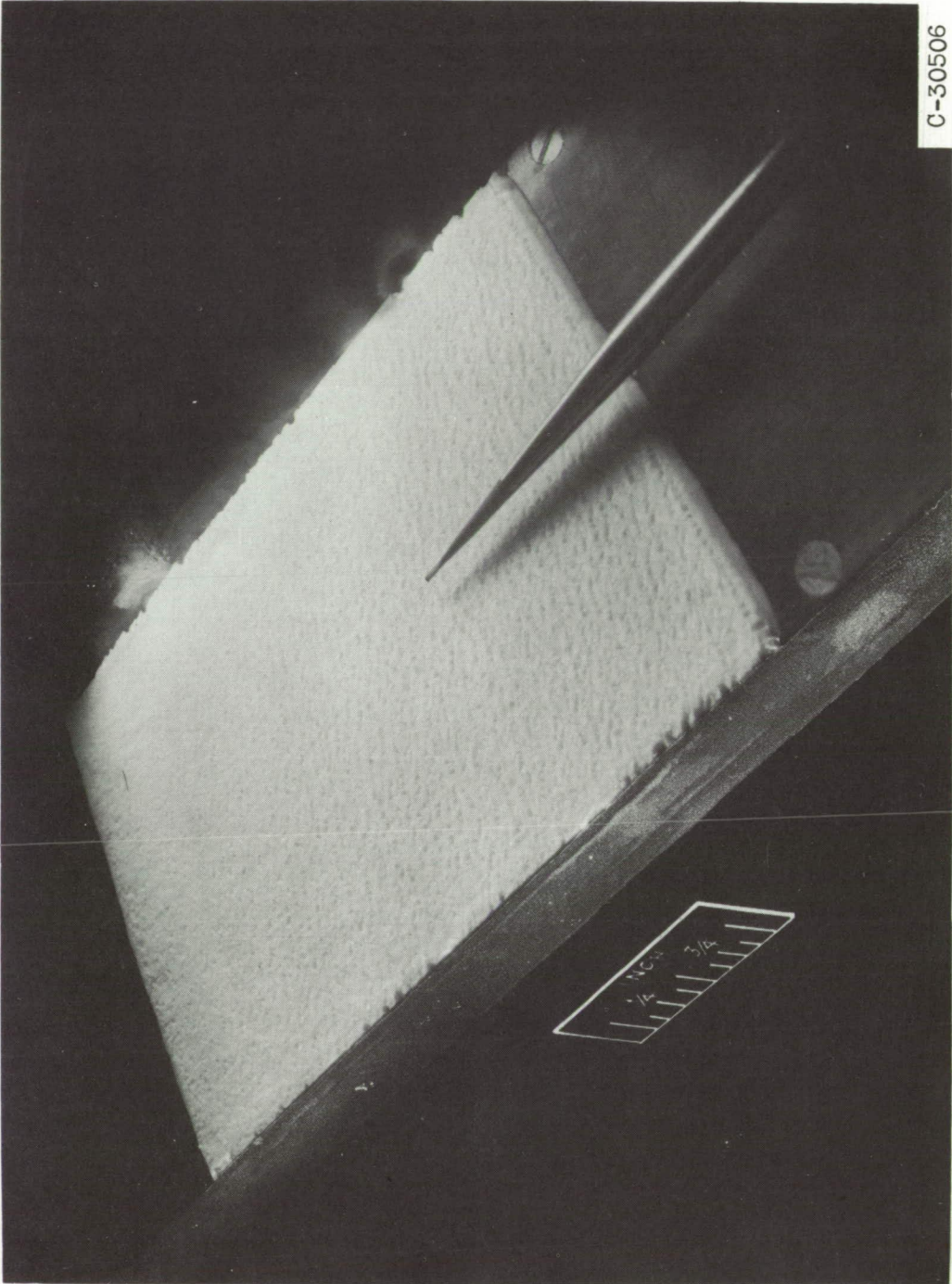

Figure 2. - Schematic diagram of apparatus for sublimation, heat-transfer, and skin-friction studies of ice on a flat plate.





C-30506

Figure 3. - Photograph of ice formation on surface of cold plate showing typical presublimation condition of iced surface.

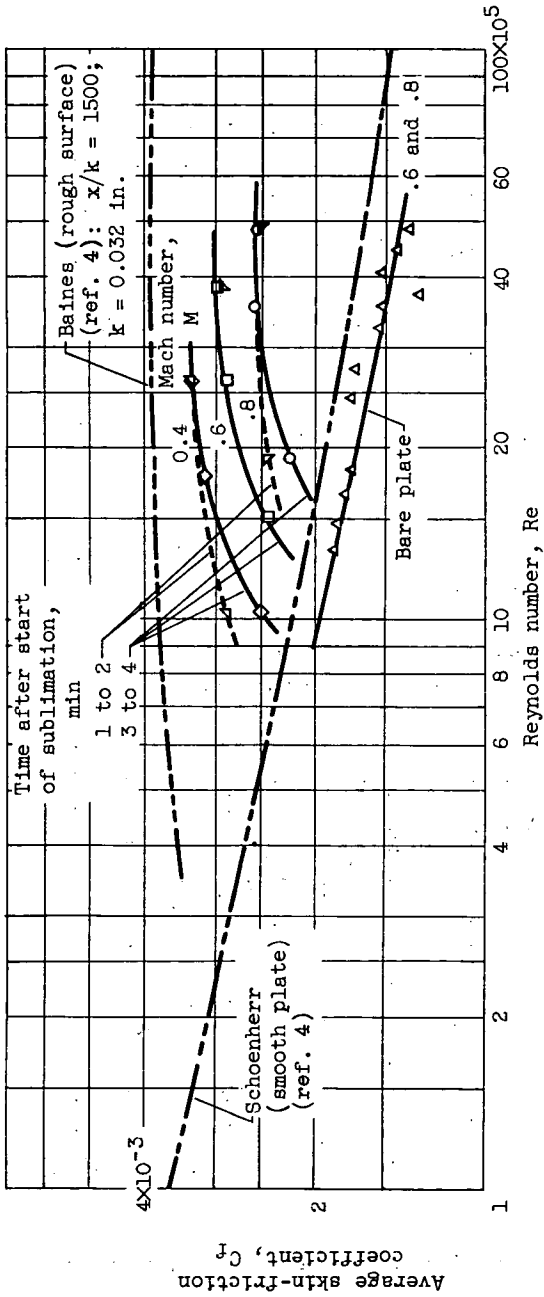

Figure 4. - Experimental values of average skin-friction coefficient for bare plate and iced plate during sublimation.

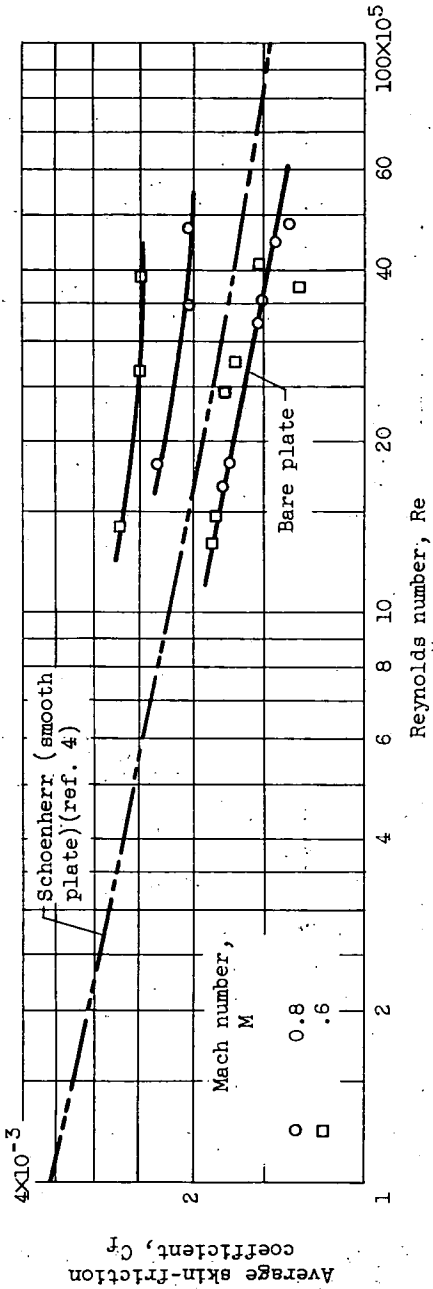

Figure 5. - Experimental values of average skin-friction coefficient for iced surface at constant ice thickness with heat transfer from air to ice.

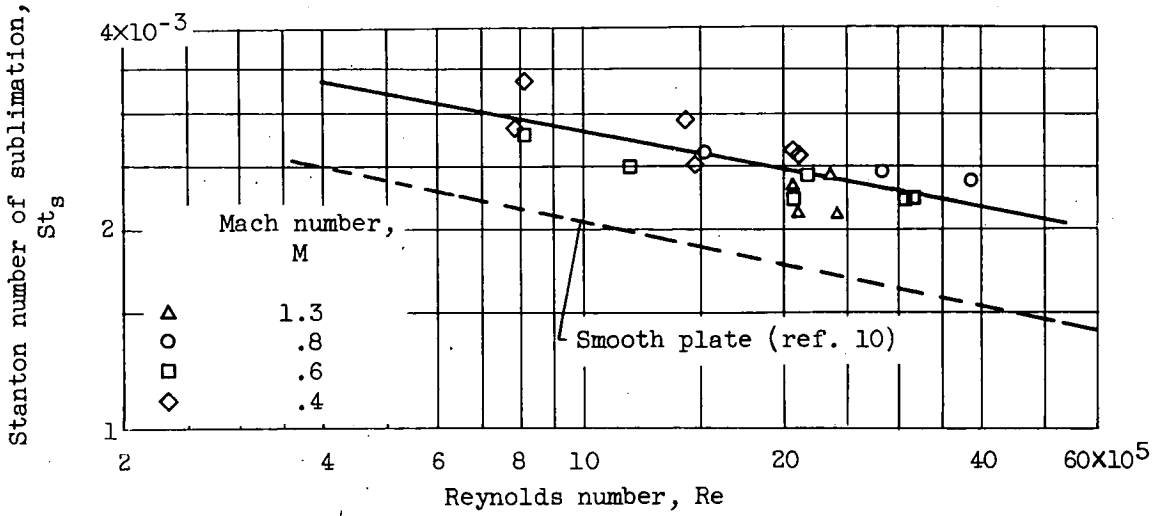

Figure 6. - Variation of sublimation Stanton number with Reynolds number for four values of Mach number. Assumed  $St_g/St_h, 0.90$ .

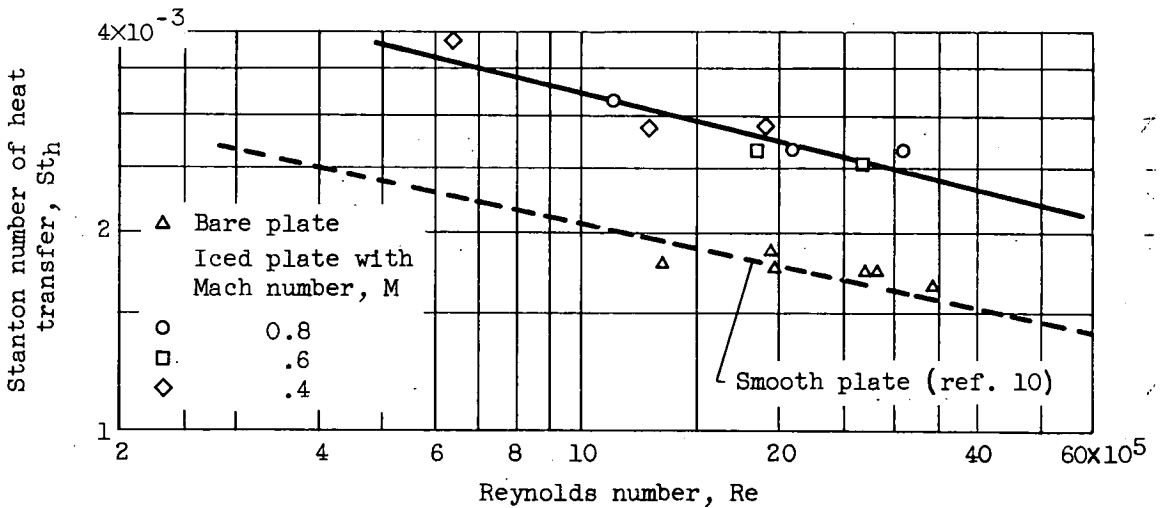

Figure 7. - Variation of heat-transfer Stanton number with Reynolds number for bare plate and iced surface.

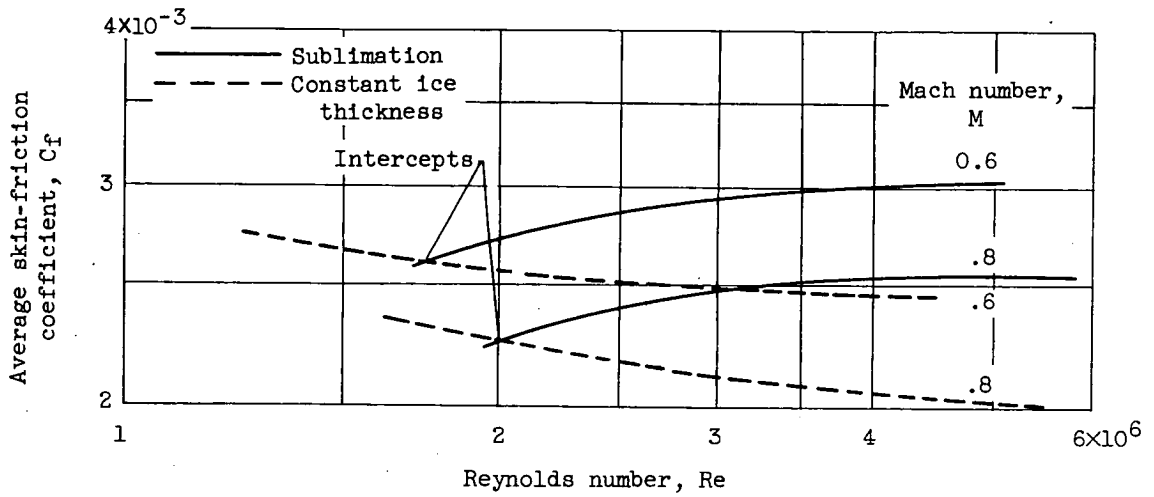

Figure 8. - Average skin-friction coefficients showing intercepts for conditions of sublimation and heat transfer with constant ice thickness for two Mach numbers.

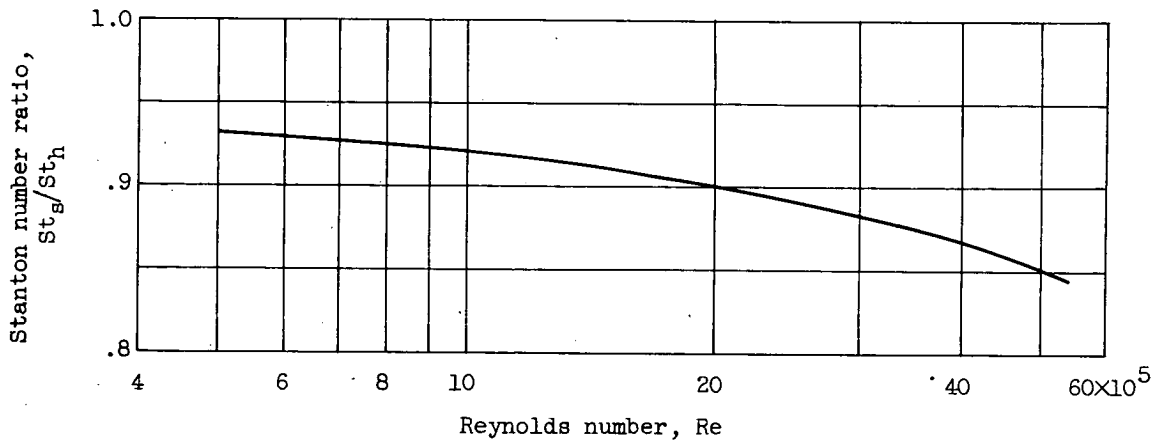
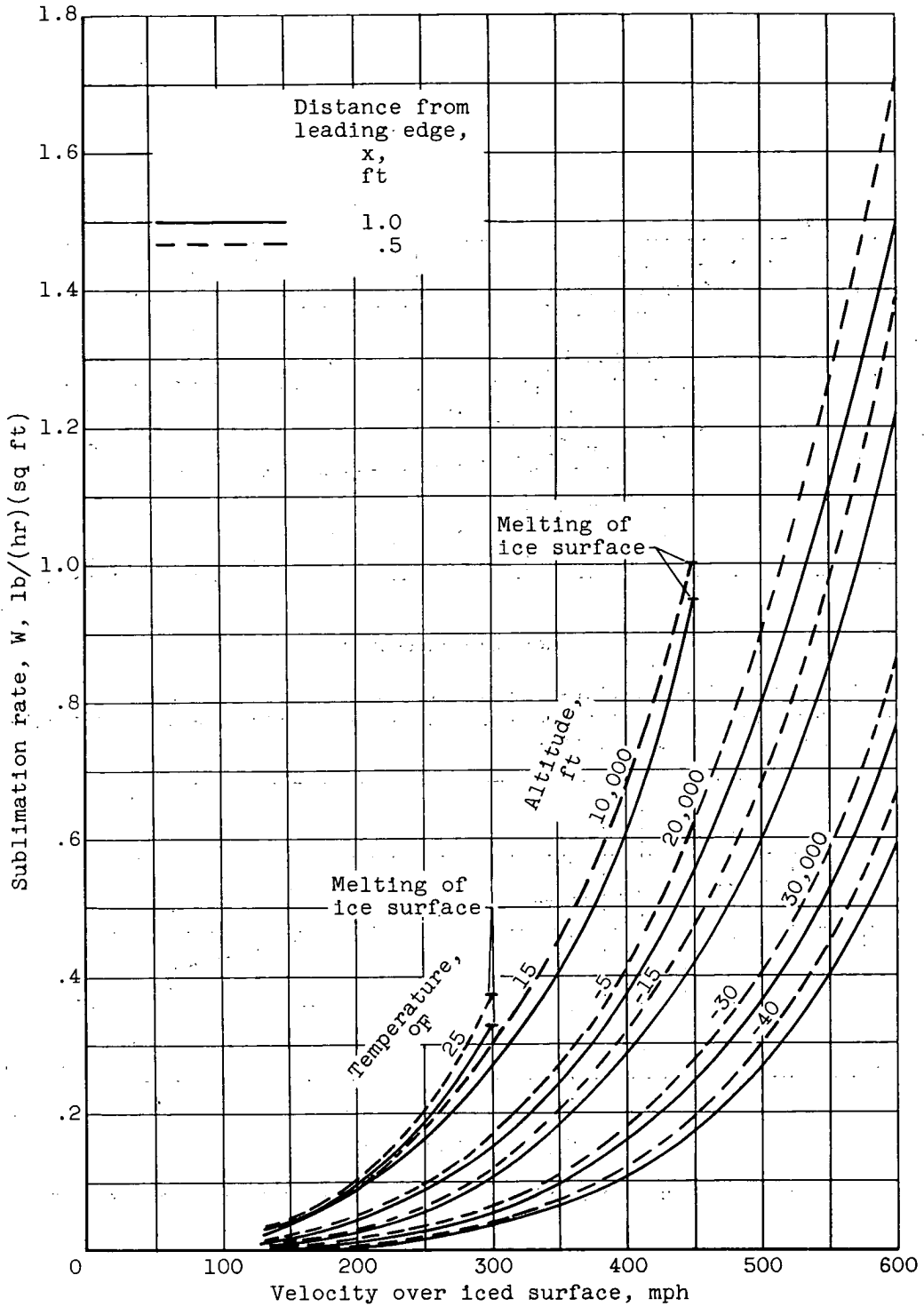
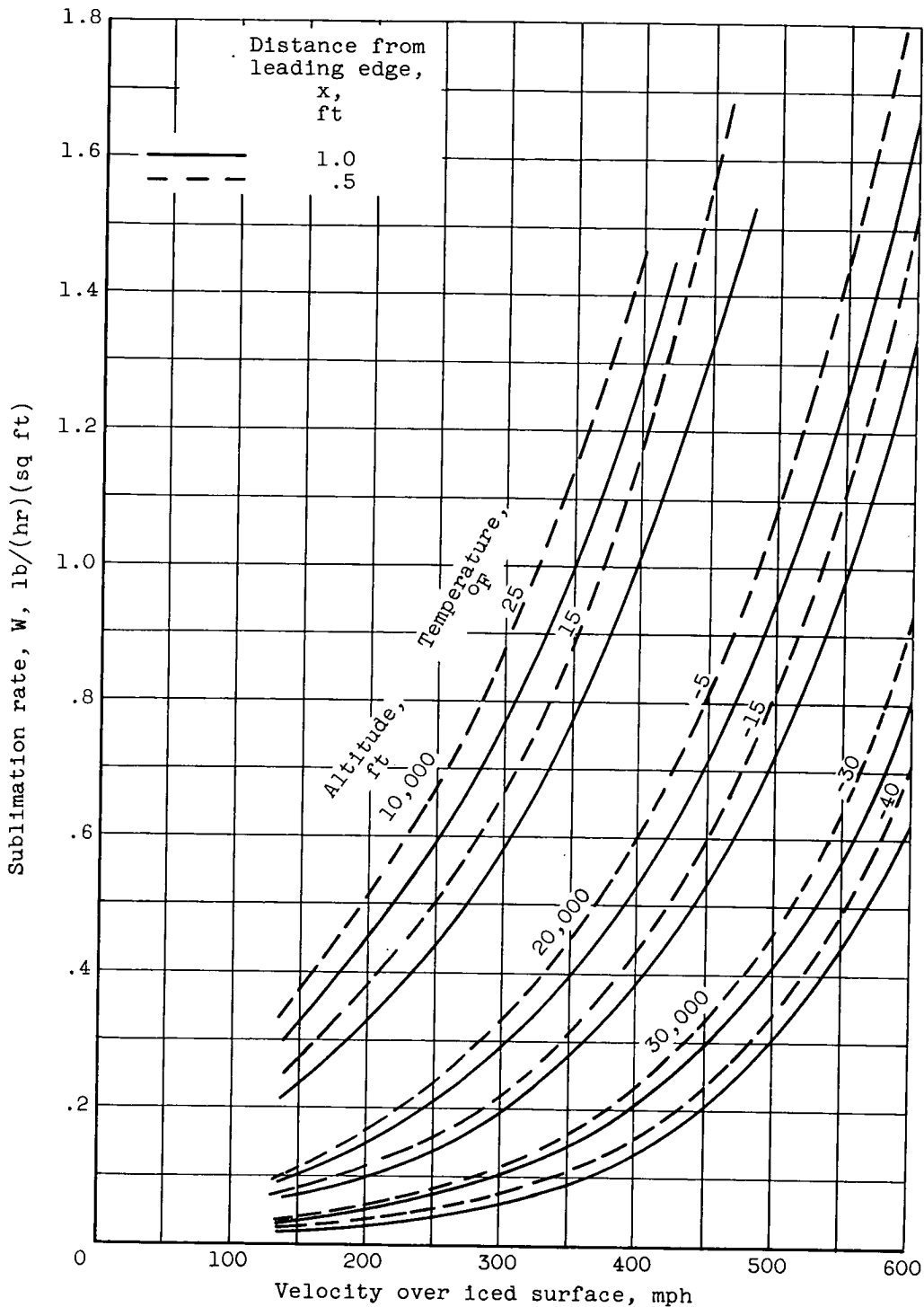

Figure 9. - Variation of Stanton number ratio with Reynolds number.



(a) Saturated air at ambient temperature.

Figure 10. - Sublimation rate as function of velocity over iced surface for two values of temperature at each of three altitudes.



(b) Dry air.

Figure 10. - Concluded. Sublimation rate as function of velocity over iced surface for two values of temperature at each of three altitudes.