

**NATIONAL ADVISORY COMMITTEE
FOR AERONAUTICS**

TECHNICAL NOTE 2510

**EXPERIMENTAL VALUES OF THE SURFACE
TENSION OF SUPERCOOLED WATER**

By Paul T. Hacker

**Lewis Flight Propulsion Laboratory
Cleveland, Ohio**



Washington

October 1951

NATIONAL ADVISORY COMMITTEE FOR AERONAUTICS

TECHNICAL NOTE 2510

EXPERIMENTAL VALUES OF THE SURFACE

TENSION OF SUPERCOOLED WATER

By Paul T. Hacker

SUMMARY

The results of surface-tension measurements for supercooled water are presented. A total of 702 individual measurements of surface tension of triple-distilled water were made in the temperature range, 27° to -22.2° C, with 404 of these measurements at temperatures below 0° C.

The increase in magnitude of surface tension with decreasing temperature, as indicated by measurements above 0° C, continues to -22.2° C. The inflection point in the surface-tension - temperature relation in the vicinity of 0° C, as indicated by the International Critical Table values for temperatures down to -8° C, is substantiated by the measurements in the temperature range, 0° to -22.2° C. The surface tension increases at approximately a linear rate from a value of 76.96 ± 0.06 dynes per centimeter at -8° C to 79.67 ± 0.06 dynes per centimeter at -22.2° C.

INTRODUCTION

The current interest in supercooled water is due in part to increased research on aircraft icing, condensation shocks in supersonic flow, and natural and artificially induced precipitation. As a result of this interest, a need has arisen for a more complete understanding of the physical properties of supercooled water because few of the physical properties of water have been investigated at temperatures much below 0° C.

Surface tension is one of the physical properties of water that influences the formation and growth of liquid-water droplets from air saturated with water vapor. This condensation process very often occurs at temperatures below 0° C in the atmosphere and in flowing gas streams that are subject to adiabatic cooling. For a complete understanding of the condensation phenomenon at temperatures below 0° C, the surface tension of water at these temperatures must therefore be evaluated. The surface tension of water has been measured to -8° C (reference 1), but some doubt exists as to the validity of the results

obtained below 0° C because of a weak inflection point in the surface-tension - temperature curve in the vicinity of 0° C. The validity of this inflection point is questionable because of the experimental difficulties involved in obtaining data at temperatures below 0° C. Because of this uncertainty, extrapolation of the surface-tension - temperature relation to very low temperatures is difficult.

The investigation reported herein was conducted to determine experimentally the surface tension of water to as low a temperature as possible. This information in combination with other facts concerning the physical properties of supercooled water would be useful in determining the time-mean structure of supercooled water and the reasons for the existence and apparent stability of supercooled water, as well as droplet formation and growth from air saturated with water vapor at temperature below 0° C.

METHOD AND THEORY

There are numerous methods for determining the surface tension of liquids, for example, capillary rise, drop weight, and tensiometer methods. Excellent summaries of most of the standard methods are presented in references 2 and 3. The standard methods, however, are unsatisfactory for the determination of surface tension of supercooled water for either or both of the following reasons:

- (1) Most methods require a knowledge of the density of the liquid, which is unknown for supercooled water at temperatures considerably below 0° C.
- (2) The volume of liquid necessary for most of the standard methods is so great that a high degree of supercooling is improbable. According to reference 4, as the volume of water is increased the degree of supercooling possible decreases.

The method adopted for this investigation is a very ingenious method devised by Ferguson (reference 5) and modified by Ferguson and Kennedy (reference 6). This method eliminates the disadvantages of the more standard methods in that the density of the liquid under measurement need not be known and the volume of liquid required is less than 1 cubic millimeter. Essentially, the method is as follows: A small quantity of water is placed in a small-bore capillary tube that is supported in a horizontal position (fig. 1). Pressure is applied to one end of the tube until the liquid is forced into such a position that the meniscus at the other ("open") end of the tube is plane instead of curved. The pressure required to force the meniscus to a plane position is proportional to the surface tension.

The method is based upon the same physical phenomenon that causes a liquid to rise in a small-bore capillary tube; namely, the pressure difference across a curved surface at a gas-liquid boundary. The pressure difference Δp across a curved liquid surface at a gas-liquid boundary is given by

$$\Delta p = \gamma \left(\frac{1}{R_1} + \frac{1}{R_2} \right) \quad (1)$$

where γ is the surface tension, and R_1 and R_2 are the principal radii of curvature at a point on the liquid surface.

For liquids in capillary tubes of circular cross section, the two principal radii at the vertex of the meniscus can be assumed to be equal and equation (1) may be reduced to

$$\Delta p = \frac{2\gamma}{R} \quad (2)$$

In figure 1 sufficient pressure p is applied to the left end of the tube to make the meniscus at A plane. When meniscus A is plane, the radius of curvature R is infinite, and Δp is zero. If the pressure P at point 1 is atmospheric, the pressure at point 2 is atmospheric also. The pressure at point 3, which is immediately inside the liquid of meniscus B, is also P if the tube is in a horizontal position. Because meniscus B is curved, there must be a pressure difference across the gas-liquid boundary if the system is to be in equilibrium. This pressure change Δp is given by equation (2). The pressure p at point 4 is therefore given by

$$p = P + \Delta p \quad (3)$$

or

$$\Delta p = p - P \quad (4)$$

If equations (2) and (4) are combined,

$$\Delta p = p - P = \frac{2\gamma}{R}$$

and the surface tension is

$$\gamma = \frac{R}{2} \Delta p \quad (5)$$

For small-bore capillary tubes, the radius of curvature R is given approximately by

$$R = \frac{r}{\cos \alpha} \quad (6)$$

where r is the radius of the capillary bore and α is the contact angle between the liquid and the tube. The contact angle for clean glass and water can be assumed to be 0° ; the radius of curvature R of the meniscus B is therefore equal to the radius of the bore of the capillary tube and equation (5) becomes

$$\gamma = \frac{1}{2} r \Delta p \quad (7)$$

In order to simplify equation (1) to the practical equation (7), the gravitational distortion of the menisci must be assumed negligible. Ferguson and Kennedy (reference 6) determined experimentally that for practical purposes the distortion is zero for capillary tubes of less than 1-millimeter bore.

APPARATUS AND PROCEDURE

The apparatus used in this investigation consisted of the following components (figs. 2 and 3): (1) a capillary tube for holding the water sample, (2) a cold bath for cooling the capillary tube and water sample, (3) a bellows and a rack and pinion gear arrangement for changing the pressure applied to the water sample, (4) a micromanometer to measure the applied pressure, (5) a light source and microscope for determining when the meniscus at the "open" end of the capillary tube is plane, and (6) a thermocouple and potentiometer for measuring and recording the temperature of the water sample.

In order for equation (7) to be valid, some precautions were necessary in the selection and preparation of the capillary tube. The bore of the tube had to be circular in cross section and uniform in diameter over the length occupied by the water sample. The "open" end of the tube had to be perpendicular to the axis of the tube and the bore at the "open" end could not be chipped or rounded. Several methods

were tried for preparing the tubes, but the most successful method was to scratch the surface of the tubing and break it by snapping. Several capillary tubes of various bore diameters were examined with a microscope equipped with a micrometer eyepiece, and one tube that fulfilled all the requirements was selected. The capillary tube selected was of soft glass about 3 inches long with a bore diameter of 0.364 ± 0.002 millimeter.

The capillary tube and water sample were cooled by suspending the capillary tube in a horizontal position in a small thermally insulated brass chamber (figs. 2 and 3) that was cooled by means of a copper rod, which was attached to the chamber and extended through the cork insulation into a bath of dry ice and the organic solvent Varsol. The chamber was provided with two plastic windows through which the "open" end of the capillary tube was illuminated and observed with a low-power microscope (fig. 3(b)). The windows were so located that the incident and reflected light made angles of 45° with the axis of the capillary tube. Condensation was prevented on the windows by a jet of warm air.

The difference between atmospheric pressure and the pressure required to force the meniscus at the "open" end of the capillary tube to a plane form was established by changing the volume of the closed system that consisted of the capillary tube with the water sample, a manometer, a metallic bellows, a 2-liter bottle, and the tubing used for connections among the various component parts. The change of volume was accomplished by changing the volume of the metallic bellows by a rack and pinion gear arrangement. The 2-liter bottle was included in the system so that a large change in volume of the bellows would correspond to a small change in pressure applied to the water sample. The pressure difference Δp was measured by a water micromanometer, by which the height of the water column could be determined to 0.003 inch. Because the meniscus sticks in the inclined portion of the micromanometer tube, the error in Δp was usually greater than 0.003 inch of water. This error was almost completely eliminated however by averaging two values of Δp , one value obtained by approaching the true value of Δp from a lower pressure and the other from a higher pressure.

The method used to determine the planarity of the meniscus was the same as that employed by Ferguson and Kennedy (reference 6). The planarity of the meniscus was determined by examining with a microscope the image of a light source formed by the meniscus. The light source was placed approximately 1 foot from the end of the capillary tube. When the meniscus is concave, the light source appears as a bright spot in the center, but as the pressure is increased the spot broadens until it covers the entire liquid surface when the meniscus is plane. If the pressure is increased further, the meniscus becomes

convex and the bright spot decreases in size with increasing pressure. The appearance of the meniscus at various stages during the increase of pressure is illustrated by the series of photographs in figure 4. The pressure changes shown were selected to illustrate the technique but do not represent the smallest change of pressure that can be detected by change in appearance of the meniscus.

The temperature of the water sample was taken to be the same as the temperature of the capillary tube. The temperature of the capillary tube was measured by a thermocouple that was cemented in a hole in the side of the capillary tube at about 1/4 inch from the "open" end. The thermocouple junction was located approximately 0.03 inch from the bore of the tube. The temperature was recorded by a strip-chart potentiometer, which could be read to the nearest 0.25° C. The accuracy of the temperature measurement was determined for one point, namely, the melting point of ice. The water sample in the capillary tube was frozen and the temperature of the chamber was slowly increased until the ice began to melt. The potentiometer indicated melting temperature and the visual observed melting temperature agreed to within ±0.25° C. The probable error in a temperature measurement due to reading errors and inherent errors in the potentiometer for the temperature range covered was of the order of ±0.3° C.

The procedure used in making the measurements of surface tension was as follows: The capillary tube was cleaned by forcing cleaning solution and distilled water through the bore. A sample of triple distilled water was then placed in the "open" end of the capillary tube by a small dropper. The quantity of water placed in the capillary tube was not accurately controlled, but the thread of liquid was usually about 1/4 inch in length. The capillary tube and water sample were suspended in the cooling chamber at room temperature and the temperature was decreased very slowly and surface-tension measurements were made until the water sample froze.

With the simple apparatus used, it was difficult to maintain constant water temperature over a long period of time, but observations of the melting of frozen water samples indicated that the true water temperature was within ±0.25° C of the indicated temperature when the temperature was changing very slowly. The temperature of the water sample was decreased in small increments by the addition of a small quantity of dry ice to the solvent in the cold bath. With each addition of dry ice, the temperature decreased about 5° C in 10 minutes and then became approximately constant for a few minutes. The average rate of decrease of temperature from room temperature to the freezing temperature of the water sample was about 1° C every 3 minutes. The temperature of the water sample was continuously recorded except when a measurement of surface tension was made, and then the trace was interrupted momentarily to mark the temperature record.

Surface-tension measurements were made at an average rate of about one per minute. For each measurement, the pressure applied to the water sample was increased until the meniscus became plane; the pressure was then increased further until the meniscus became convex; and then the pressure was decreased until the meniscus became plane again. The two pressure measurements recorded when the meniscus of the water sample was plane were averaged and used as the pressure difference Δp of equation (7). This procedure not only reduced the error caused by the micromanometer fluid sticking, but also virtually eliminated the possible error involved in the making of the decision that the meniscus of the water sample was plane. The time required to make the two separate readings was about 12 seconds. The temperature change during this time interval was usually less than 0.1°C ; therefore, the average temperature during this period was considered to be the temperature corresponding to the surface-tension value. Because there are some uncertainties associated with the numerical values of capillary bore size and the pressure difference Δp of equation (7) as well as the assumption that the meniscus contact angle is zero, measurements of surface tension were made at temperatures above 0°C in order to compare the values obtained by this method with those published in the International Critical Tables (reference 1).

RESULTS AND DISCUSSION

The surface tension of water was measured 702 times in the temperature range 27° to -22.2°C , with 404 measurements at temperatures below 0°C . Seven different samples of triple-distilled water were used. The experimental values of surface tension in dynes per centimeter are shown as a function of temperature in degrees centigrade in figure 5. Also shown in this figure is a curve representing the values of surface tension from 27° to -8°C as given in the International Critical Tables (reference 1). The distribution of the deviations of experimental values from the International Critical Table values is shown in figure 6. Approximately 64 percent of all experimental values are within ± 0.125 dyne per centimeter of the International Critical Table values. The average deviation of the experimental values from the International Critical Table values is 0.03 dyne per centimeter and the root-mean-square deviation is 0.142 dyne per centimeter. A deviation of ± 0.125 dyne per centimeter at 0°C is equivalent to an error of ± 0.17 percent in the value of surface tension if the International Critical Table value is assumed to be correct. The individual measurements of surface tension (fig. 5) at temperatures below -8°C show about the same scatter as those above -8°C , therefore, the accuracy of these measurements should be comparable.

Because there is an insufficient number of surface-tension measurements at any given temperature to determine the most probable value, and the possible error in the temperature of the water sample was about $\pm 0.3^{\circ}\text{C}$, the individual values of surface tension for temperature intervals of 1° were grouped and an average value was calculated. The

results of these calculations are presented in figure 7 and table I. The temperature associated with each average value of surface tension is the midpoint of the temperature interval over which the individual values were grouped. The International Critical Table values are also presented in figure 7 and table I for comparison. The average deviation of the average values from the International Critical Table values is ± 0.03 dyne per centimeter, whereas the root-mean-square deviation is 0.06 dyne per centimeter. The agreement between the average values and the International Critical Table values in the temperature range, 27° to -8° C is better than might be predicted from the possible uncertainties associated with the numerical values of the factors involved in equation (7). The values determined for these factors must therefore be approximately true values; if errors do exist, however, they compensate for one another.

A close inspection of the International Critical Table values presented in figure 7 or table I shows that the rate of increase in the value of surface tension, with decreasing temperature, decreases from 27° to approximately 0° C and then starts to increase at lower temperatures; a weak inflection point in the surface-tension - temperature curve must therefore exist in the vicinity of 0° C. Some doubt exists, however, concerning the validity of the inflection point because of the experimental difficulties involved in obtaining data at temperatures below 0° C. In the temperature range, -8° to -22.2° C, however, the measurements obtained in this investigation are consistent with the existence of this inflection point. The average values of surface tension (fig. 7) indicate that surface tension increases at approximately a linear rate from 76.96 ± 0.06 dynes per centimeter at -8° C to 79.67 ± 0.06 dynes per centimeter at -22.2° C, and the rate of increase of surface tension with decreasing temperature is greater in the temperature range, -5° to -22.2° C than in the range, 27° to -5° C.

CONCLUSIONS

The surface tension of water in the supercooled region continues to increase in magnitude with decreasing temperature, as it does above 0° C, and reaches a value of 79.67 ± 0.06 dynes per centimeter at -22.2° C. The inflection point in the vicinity of 0° C indicated by the International Critical Table values appears to be real and the rate of increase of magnitude of surface tension with decreasing temperature is larger in the temperature range, -5° to -22.2° C than in the range, 27° to -5° C.

Lewis Flight Propulsion Laboratory
National Advisory Committee for Aeronautics
Cleveland, Ohio, July 25, 1951

REFERENCES

1. Young, T. Fraser, and Harkins, William D.: Surface-Tension Data for Certain Pure Liquids Between 0 and 360° and for All Types of Solutions at All Temperatures. International Critical Tables, Edward W. Washburn, ed., vol. IV, 1928, pp. 446-475.
2. Adam, Neil Kensington: The Physics and Chemistry of Surfaces, Clarendon Press (Oxford), 2d ed., 1938, pp. 1-13; 363-388.
3. Bikerman, J. J.: Surface Chemistry for Industrial Research, Academic Press Inc., 1948, pp. 1-20.
4. Dorsch, Robert G., and Hacker, Paul T.: Photomicrographic Investigation of Spontaneous Freezing Temperatures of Supercooled Water Droplets. NACA TN 2142; 1950.
5. Ferguson, Allan: On the Measurement of the Surface Tension of a Small Quantity of Liquid. Proc. Phys. Soc., London, vol. XXXVI, Dec. 1923-Aug. 1924, pp. 37-43.
6. Ferguson, Allan, and Kennedy, S. J.: Notes on Surface-Tension Measurement. Proc. Phys. Soc., London, vol. 44, May 20, 1932, pp. 511-515.

TABLE I - COMPARISON OF EXPERIMENTAL VALUES
OF SURFACE TENSION WITH INTERNATIONAL

CRITICAL TABLE VALUES¹



Temperature (°C)	Experimental values ² (dynes/cm)	International Crit- ical Table values ³ (dynes/cm)
27.5	71.58	71.58±0.05
26.5	71.78	71.74±.05
25.5	-----	71.90±.05
24.5	72.03	72.05±.05
23.5	72.12	72.20±.05
22.5	72.40	72.36±.05
21.5	72.52	72.52±.05
20.5	72.73	72.67±.05
19.5	72.83	72.83±.05
18.5	73.03	72.98±.05
17.5	73.12	73.12±.05
16.5	73.27	73.26±.05
15.5	73.52	73.42±.05
14.5	73.54	73.56±.05
13.5	73.74	73.71±.05
12.5	73.89	73.86±.05
11.5	74.05	74.00±.05
10.5	74.21	74.14±.05
9.5	74.38	74.29±.05
8.5	74.39	74.43±.05
7.5	74.63	74.57±.05
6.5	74.81	74.71±.05
5.5	74.89	74.85±.05
4.5	75.03	74.99±.10
3.5	75.17	75.14±.10
2.5	75.20	75.28±.10
1.5	75.53	75.42±.10
0.5	75.60	75.57±.10
-0.5	75.81	75.72±.10
-1.5	75.97	75.87±.10
-2.5	76.05	76.03±.10
-3.5	76.20	76.19±.10
-4.5	76.27	76.34±.10
-5.5	76.47	76.51±.20
-6.5	76.60	76.69±.25
-7.5	76.77	76.87±.30
-8.5	77.02	-----
-9.5	77.21	-----
-10.5	77.51	-----
-11.5	77.46	-----
-12.5	77.69	-----
-13.5	77.92	-----
-14.5	78.18	-----
-15.5	78.34	-----
-16.5	78.58	-----
-17.5	78.70	-----
-18.5	78.90	-----
-19.5	79.09	-----
-20.5	79.25	-----
-21.5	79.48	-----
-22.5	79.67	-----

¹Reference 1.

²Average values of individual measurements for each °C.

³Interpolated values.

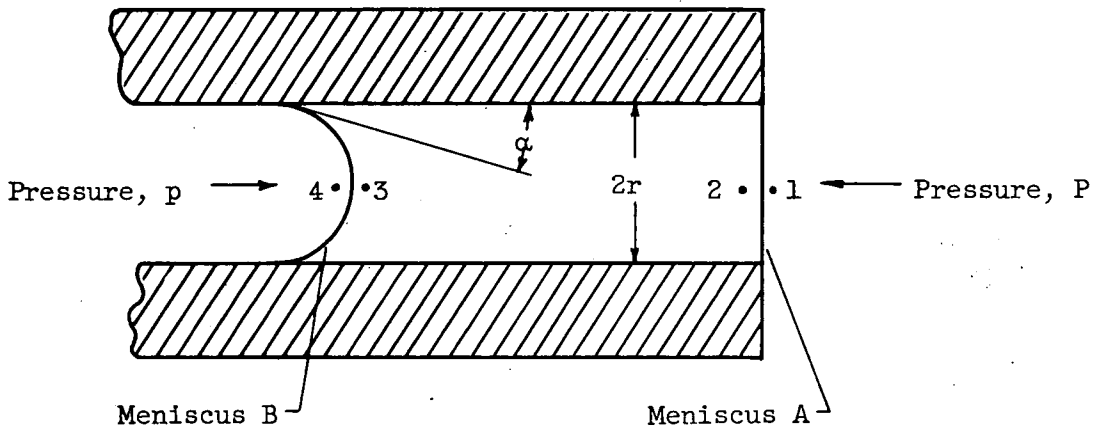

Figure 1. - Water sample in capillary tube with sufficient pressure applied to left end of tube to cause the meniscus at the right ("open") end to be plane.

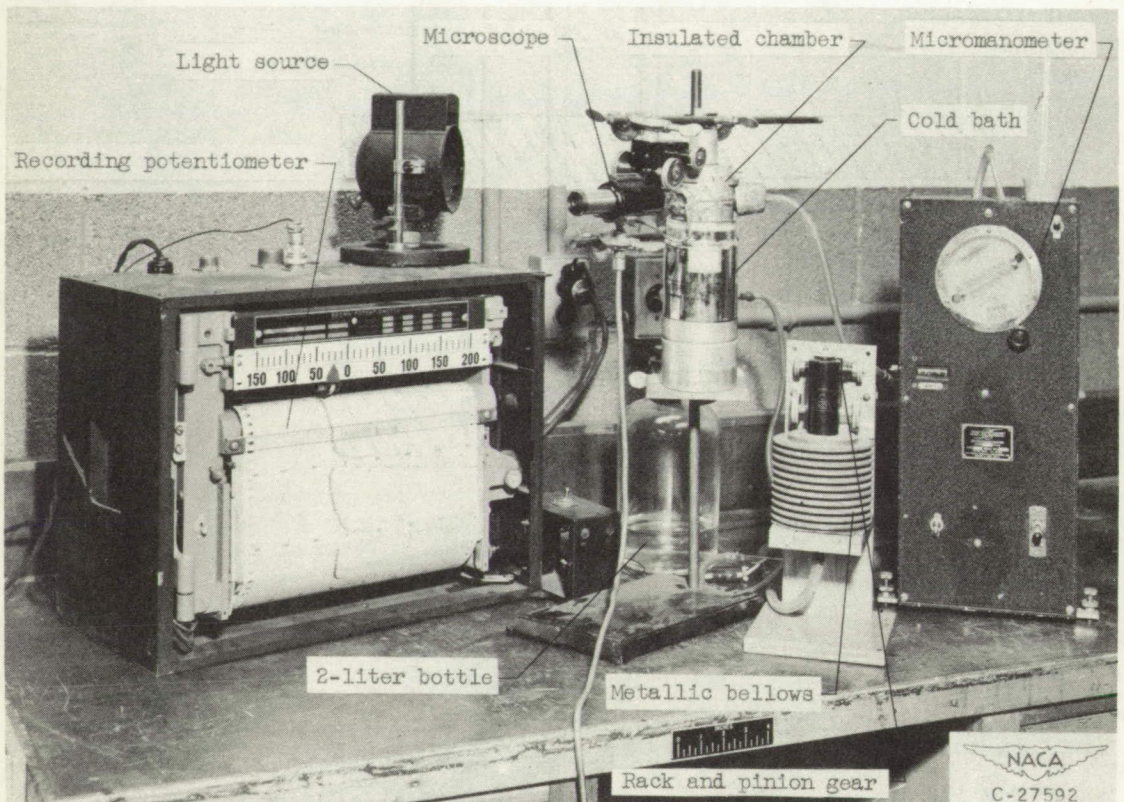
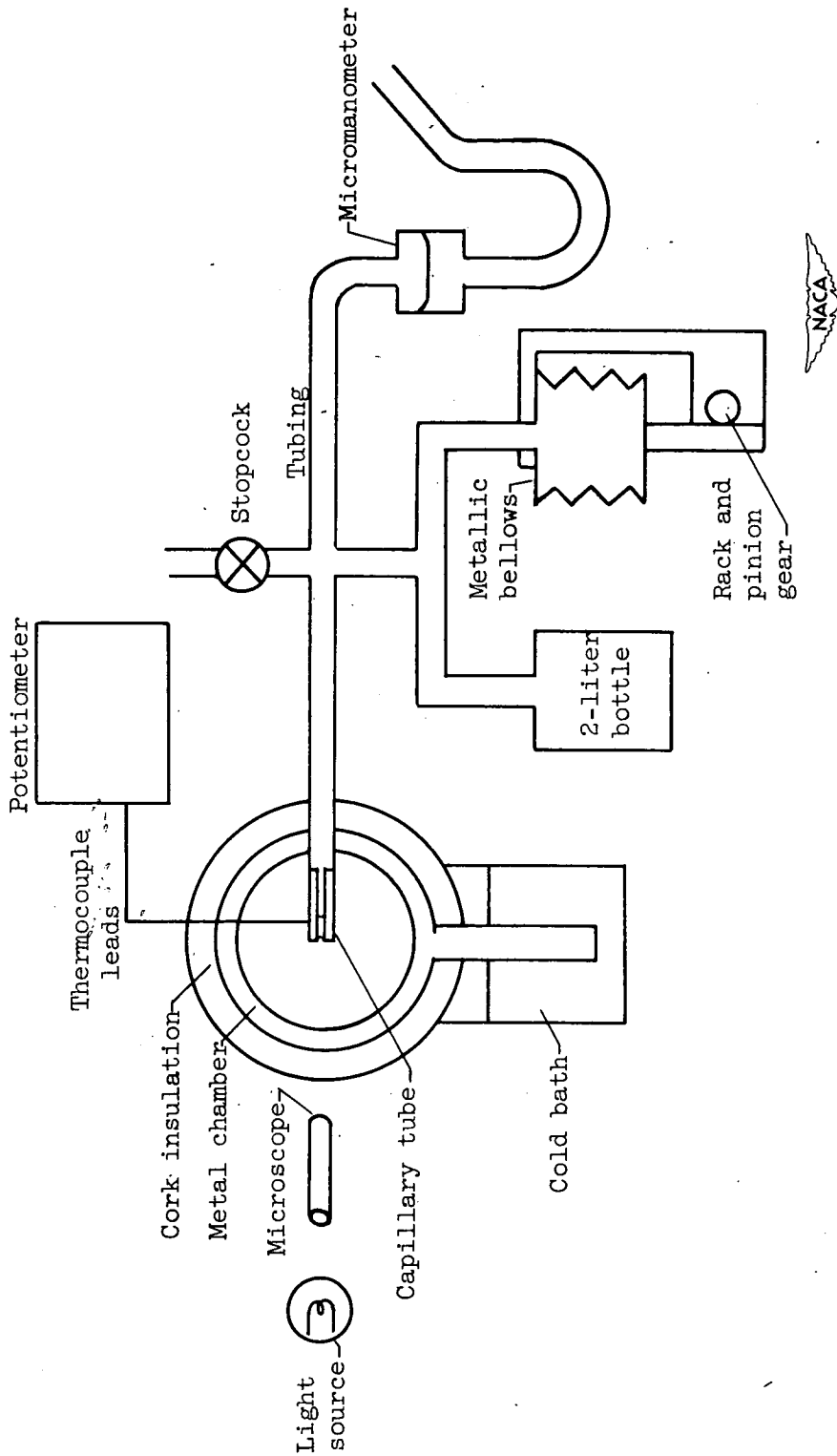
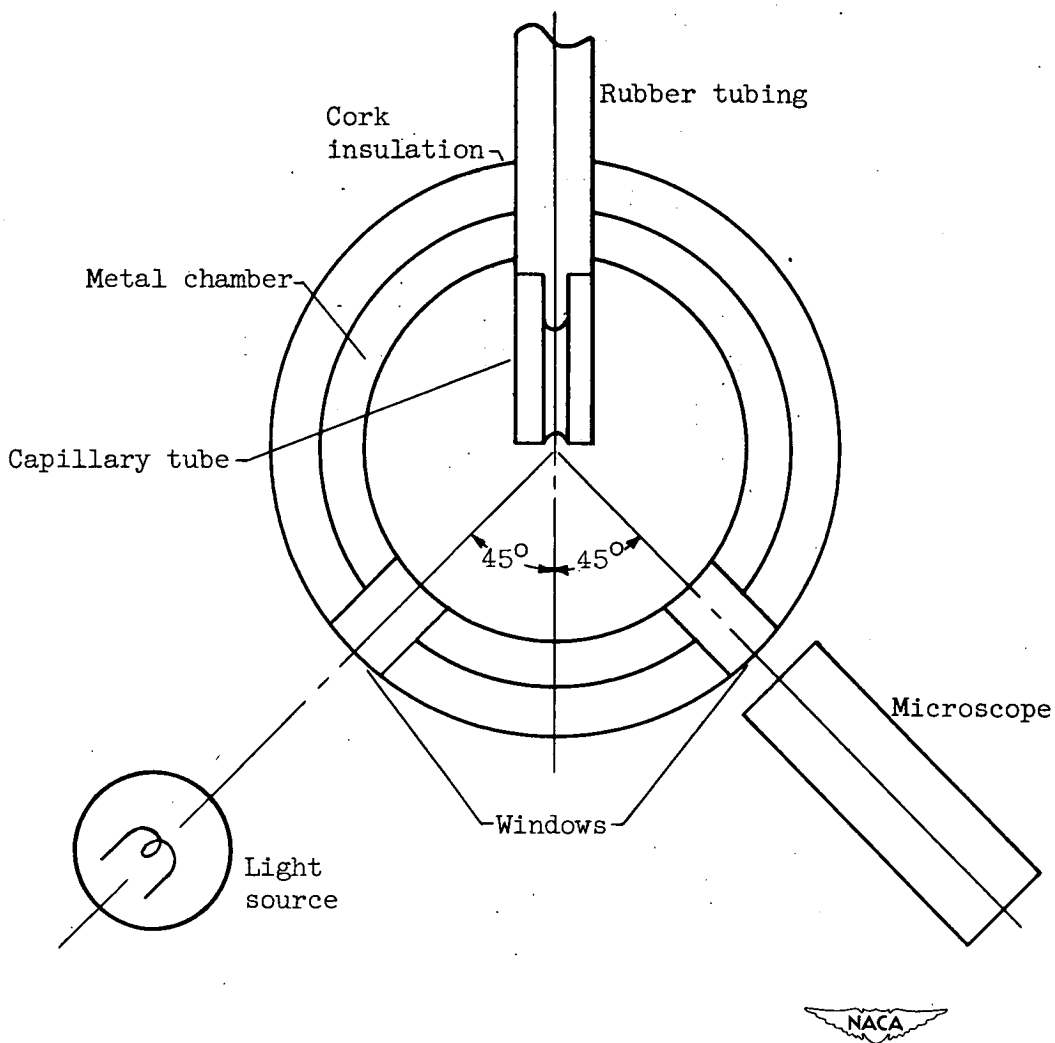

Figure 2. - Photograph of apparatus.



(a) General view of apparatus.

Figure 3. - Schematic diagrams of apparatus.



(b) Arrangement of capillary tube, light source, and microscope with respect to metal chamber.

Figure 3. - Concluded. Schematic diagrams of apparatus.



Δp , in. water, 0
Meniscus, concave



Δp , in. water, 0.542
Meniscus, concave



Δp , in. water, 1.085
Meniscus, concave



Δp , in. water, 1.642
Meniscus, concave



Δp , in. water, 2.187
Meniscus, concave



Δp , in. water, 2.703
Meniscus, concave



Δp , in. water, 3.141
Meniscus, plane



Δp , in. water, 3.418
Meniscus, convex



Δp , in. water, 3.719
Meniscus, convex



Δp , in. water, 4.021
Meniscus, convex



Δp , in. water, 4.333
Meniscus, convex



Δp , in. water, 4.641
Meniscus, convex

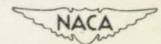

C-28203

Figure 4. - Appearance of illuminated meniscus for various applied pressures.

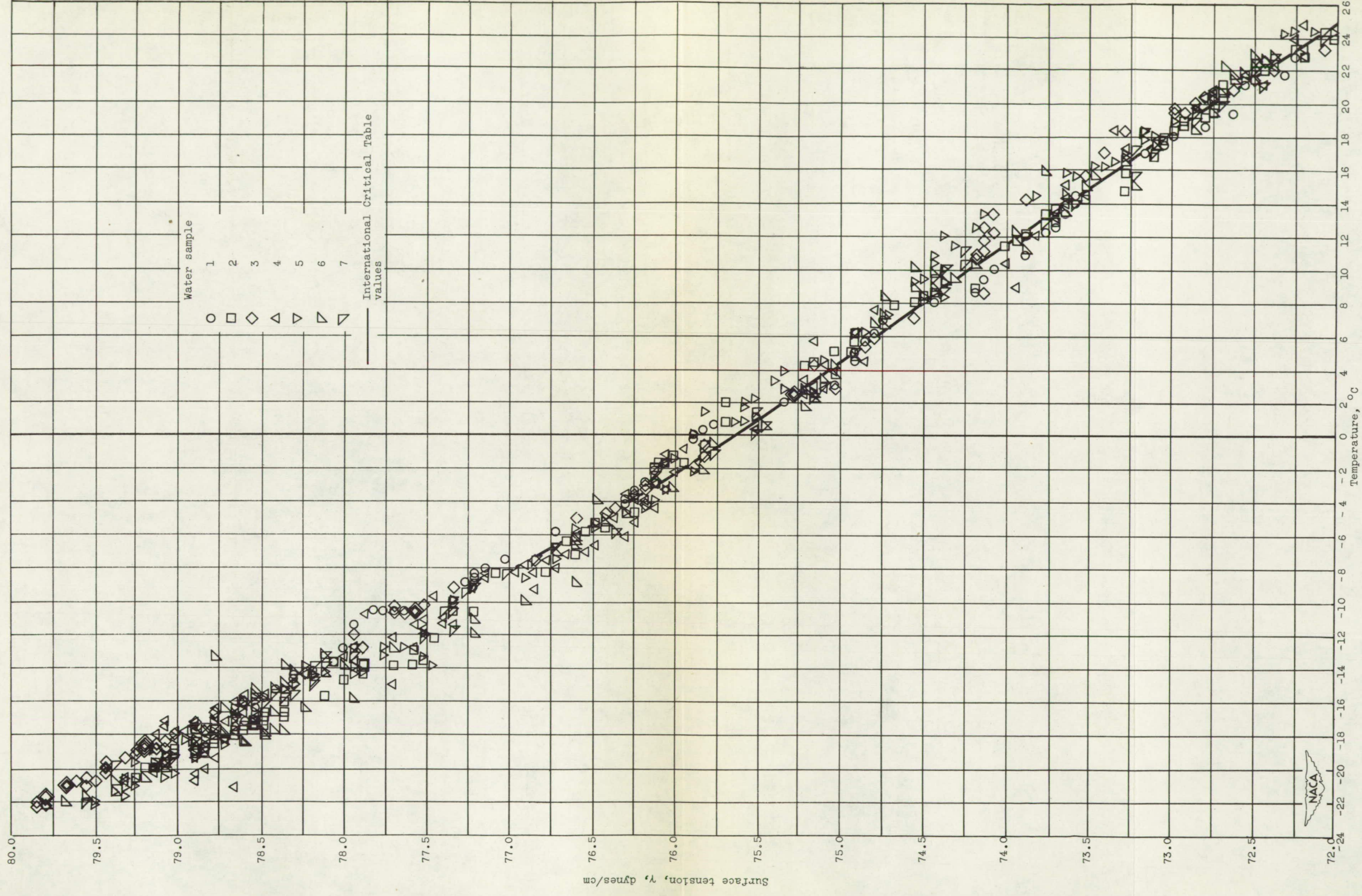

Figure 5. - Experimental values of surface tension of water.

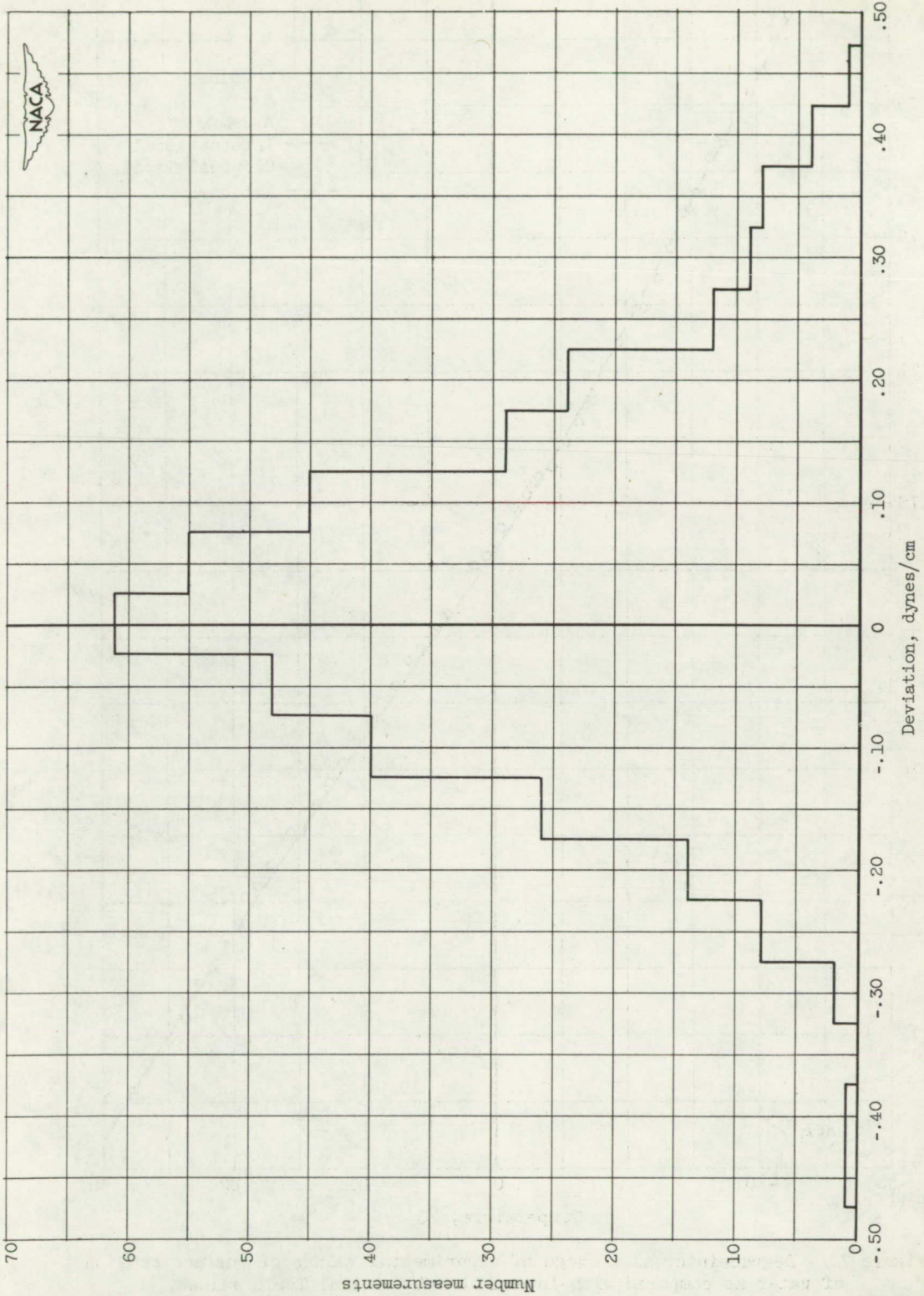

Figure 6. - Deviations of experimental values of surface tension of water from International Critical Table values.

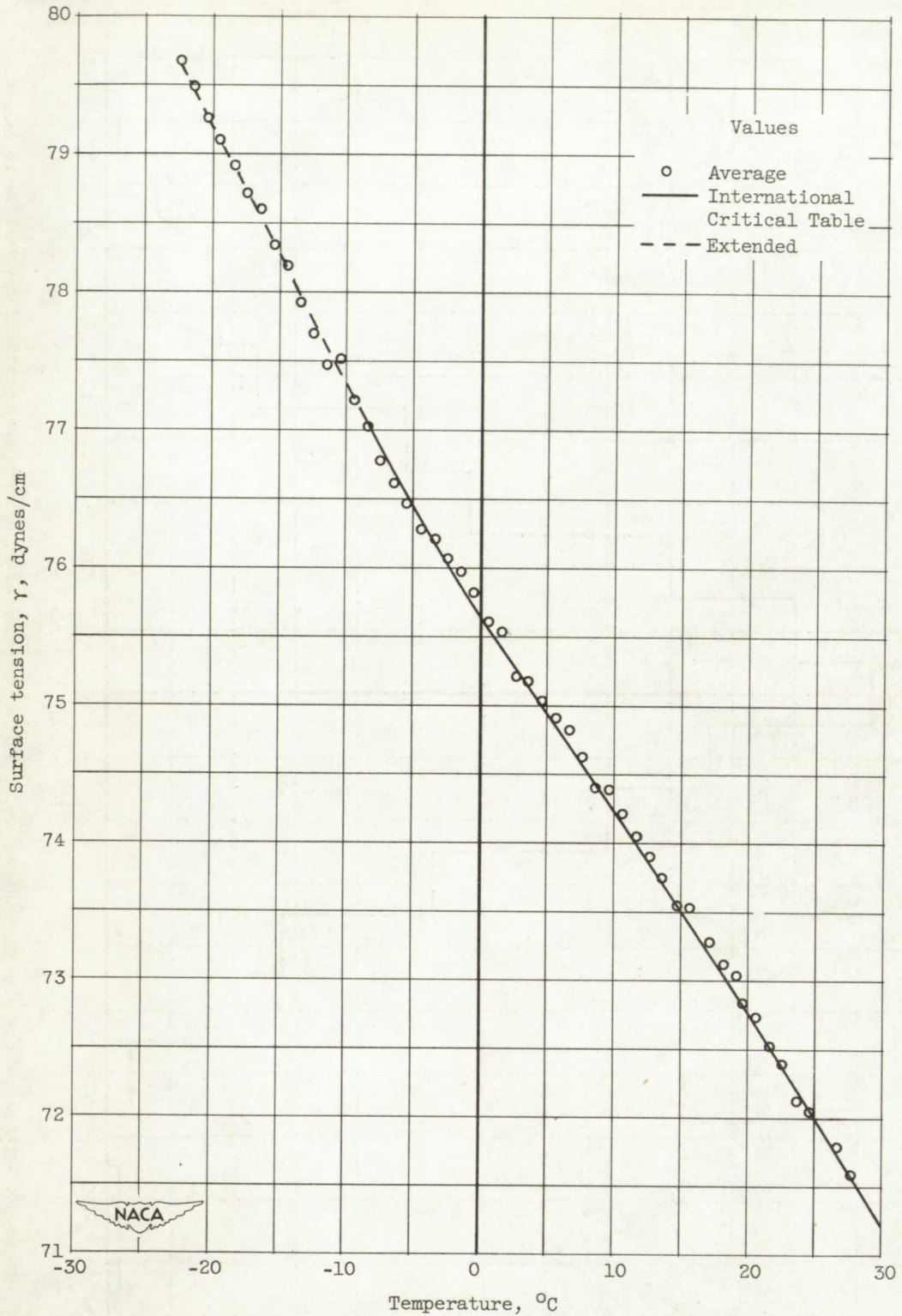

Figure 7. - Degree-interval average of experimental values of surface tension of water as compared with International Critical Table values.