

N O T I C E

THIS DOCUMENT HAS BEEN REPRODUCED FROM
MICROFICHE. ALTHOUGH IT IS RECOGNIZED THAT
CERTAIN PORTIONS ARE ILLEGIBLE, IT IS BEING RELEASED
IN THE INTEREST OF MAKING AVAILABLE AS MUCH
INFORMATION AS POSSIBLE

THIS NASA INVENTION APPEARS TO HAVE
EXCELLENT COMMERCIAL POTENTIAL

NASA CASE NO. LEW-12,950-1

PRINT FIG. ONLY 1 Figure

NOTICE

The invention disclosed in this document resulted from research in aeronautical and space activities performed under programs of the National Aeronautics and Space Administration. The invention is owned by NASA and is, therefore, available for licensing in accordance with the NASA Patent Licensing Regulation (14 Code of Federal Regulations 1245.2).

To encourage commercial utilization of NASA-owned inventions, it is NASA policy to grant licenses to commercial concerns. Although NASA encourages nonexclusive licensing to promote competition and achieve the widest possible utilization, NASA will consider the granting of a limited exclusive license, pursuant to the NASA Patent Licensing Regulations, when such a license will provide the necessary incentive to the licensee to achieve early practical application of the invention.

Address inquiries and all applications for license for this invention to NASA Patent Counsel, Lewis Research Center, Mail Code 500-318, 21000 Brookpark Rd., Cleveland, OH 44135.

Approved NASA forms for application for nonexclusive or exclusive license are available from the above address.

(NASA-CASE-LEW-12950-1) HIGH THERMAL POWER
DENSITY HEAT EXCHANGER Patent Application
(NASA) 10 P HC A02/MF A01 CSCI 20D

N82-11399

G3/34

Unclas
13553

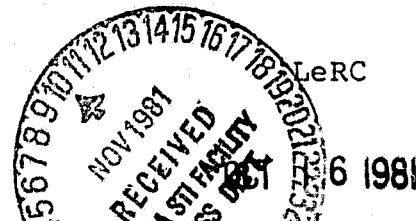

AbstractHigh Thermal Power Density Heat Transfer

This invention is directed to transferring heat from an extremely high temperature source to an electrically isolated lower temperature receiver. The invention is particularly concerned with supplying thermal power to a thermionic converter from a nuclear reactor with electric isolation.

Heat from a high temperature heat pipe (10) is transferred through a vacuum or a gap filled with electrically nonconducting gas (26) to a cooler heat pipe (18). The heat pipe (10) is used to cool the nuclear reactor while the heat pipe (18) is connected thermally and electrically to a thermionic converter (22).

If the receiver requires greater thermal power density, geometries are used with larger heat pipe areas for transmitting and receiving energy than the area for conducting the heat to the thermionic converter. In this way the heat pipe capability for increasing thermal power densities compensates for the comparatively low thermal power densities through the electrically non-conducting gap between the two heat pipes.

INVENTOR: JAMES F. MORRIS

EMPLOYER: NASA Lewis Res. Ctr., *Cleveland, OH*

EVALUATOR: W. Moeckel

SERIAL NO: 202,228

FILING DATE: 10-30-80

211006282/29

ORIGINAL PAGE IS
OF POOR QUALITY

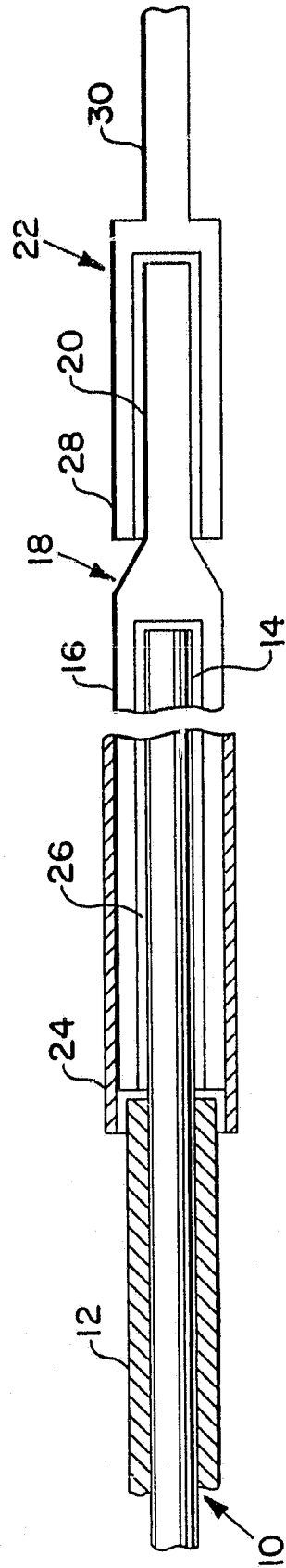

2010

202,238

Description

High Thermal Power Density Heat Transfer

Origin of the Invention

The invention described herein was made by an employee of the
5 United States Government and may be manufactured and used by or
for the Government for governmental purposes without the payment
of any royalties thereon or therefor.

Technical Field

This invention is concerned with transferring heat from an
10 extremely high temperature source to a thermionic converter.
The invention is particularly applicable to the use of a high
temperature thermionic energy converter with a heat pipe cooled
reactor.

It has been proposed to transport the heat produced in a
15 nuclear reactor to the emitting surfaces of thermionic diodes
located outside the reactor. For power conditioning purposes it
is desirable to electrically isolate the thermionic energy
converters from the heat pipes that cool the reactor.

While the heat pipes are capable of supplying very high
20 thermal power densities to the thermionic converter, problems of
electric isolation have been encountered. Conventional
insulators deteriorate in such applications because of the
extremely high temperatures involved.

Background Art

25 Janner et al patent No. 3,444,400, Hobson patent No.
3,548,222, and Gross et al patent No. 3,578,991 disclose
thermionic converter fuel elements. The thermionic converters
are heated by inserting the fuel elements directly into the
cores of nuclear reactors.

30 The thermionic converter disclosed in Rasor et al patent No.
3,983,423 has a heat source for heating an emitter. This heat
source may be a nuclear reactor fuel element, hot liquid metal
flowing in a tube, or other means.

Leventhal patent No. 3,451,641 teaches the use of a heat pipe
35 to transfer heat from a nuclear reactor to a thermal electric
converter.

Disclosure of Invention

This invention is based on the phenomenon that heat pipes not only transport high thermal power densities, but also transform thermal power densities. More particularly, a heat pipe can receive heat through its evaporator walls at low thermal power densities and deliver heat through its condenser walls at much higher thermal power densities.

According to the invention, heat is transferred from a high temperature heat pipe having an evaporator that cools a nuclear reactor to a cooler heat pipe connected thermally and electrically to the intended receiver, which is the emitter in a thermionic converter. More particularly, the condenser of the high temperature heat pipe heats the evaporator of the thermionic converter heat pipe. The condenser of this cooler heat pipe heats the emitter of the thermionic converter. This heat is transferred between the heat pipes through a vacuum or electrically non-conducting gas.

A collector in the form of a sodium heat pipe is spaced from an emitter heat pipe. The evaporator of the sodium heat pipe cools the collector of the thermionic converter. This collector receives electric energy, thermal conduction, and radiant heat from the emitter. The collector heat pipe operates at a temperature of about 1000° K. At this temperature a solid insulator may be used to cover and electrically isolate the collector.

If the receiver requires greater thermal power densities than those transferred between the two heat pipes, geometries are used with larger heat pipe areas for transmitting and receiving energy than the area for conducting the heat to the receiver. In this manner the heat pipe capability for "stepping up" thermal power densities compensates for the comparatively low thermal power densities through the electrically non-conducting gap between the heat pipes.

Brief Description of the Drawing

The details of the invention will be described in connection with the accompanying drawing which is an axial section view taken through a system of heat pipes constructed in accordance with the present invention.

Best Mode for Carrying out the Invention

Referring to the drawing there is shown a tubular heat pipe extending from a nuclear reactor, not shown. It is

contemplated that both the wick and the envelope of this heat pipe may be of a tungsten, 25% rhenium alloy. The heat pipe is covered with a non-contacting multifoil radiation shield 12,

The heat pipe 10 operates at a temperature of about 1900° K and contains lithium as the working fluid. The evaporator of the lithium heat pipe 10 cools the core of a nuclear reactor in a manner well known in the art.

The heat pipe 10 has a tubular condenser 14 that extends into a cylindrical evaporator portion 16 of a heat pipe 18 having a condenser portion 20 which forms the emitter of a thermionic converter 22. The wick and envelope of the heat pipe 18 preferably are of a molybdenum alloy, although a tungsten, 25% rhenium alloy could be used. Here again, a non-contacting multifoil radiation shield 24 covers the heat pipe 18, and lithium is the working fluid.

The tubular condenser 20 of the heat pipe 18 extends into a cylindrical evaporator portion 28 of a third heat pipe. The evaporator 28 forms the collector of the thermionic converter 22, and heat from the evaporator 28 is transported to a condenser portion 30 at the opposite end. The collector heat pipe uses sodium as its working fluid, which operates at about 1000° K. At this temperature a solid insulator may be used with the collector.

An important feature of the invention is that the heat pipes 10 and 18 are electrically isolated from each other. More particularly, the heat pipe 10 is spaced inwardly from the heat pipe 18. A vacuum or electrically non-conducting gas is in space 26 between these heat pipes. The black body radiation of the high temperature heat pipe 10 operating at 1900° K is 74W/cm². The emitter heat pipe 18 which is heated by this radiation operates at about 1700°K. At this temperature the black body radiation of the heat pipe 18 is about 47.4 W/cm².

The assumed emissivities of the reactor and converter-emitter heat pipes in the drawing are 0.3. This gives a form factor of 0.176 for a very small vacuum gap. The thermionic converter 22 is assumed to generate 4.7 W/cm² of electric output at 20% efficiency. More particularly, for the 1900° K heat pipe 10, the 1700° K heat pipe 18, and the small intervening vacuum gap

26, the net radiant heat transfer, $q_r = F(q_{BB,HT} - Q_{BB,LT})$, equals the form factor (0.176) times the difference of the 1900° K and 1700° K black body radiation thermal power densities (74 W/cm² - 47.4 W/cm²). Therefore, $q = 0.176 (74 - 47.4) = 4.68 \text{ W/cm}^2$.

In this embodiment approximately 5 times as much area is required for the radiant-heat transfer between the heat pipes as for the total power transfer across a 10 mil converter electrode gap. The heat pipes readily allow such transformation of thermal power densities. Also, the vacuum gap between the heat pipes isolates the thermionic converter electrically.

For the previously cited example, using a 1850° K heat pipe 10 and a 1750° K heat pipe 18 results in half the heat pipe 10 - to - 18 radiant flux compared with the 1900° K - 1700° K example; $q_r = 0.176 (66.6 - 53.3) = 2.34 \text{ W/cm}^2$. Therefore, the 1850° K - 1750° K embodiment will require twice the area calculated for the 1900° K - 1700° K radiant heat transfer or ten times the thermionic emitter area.

Using a one-millimeter gap filled with electrically non-conducting gas rather than vacuum between heat pipes 10 and 18 will intensify heat transfer. This can be illustrated by considering 1800° K gases at one atmosphere. Between less than 0.01 atmosphere and 10 atmospheres, the effect of pressure on thermal conductivity of gas is small, being about one percent per atmosphere, and can be ignored in this example.

Helium would add to the radiant heat transfer 0.88 times the heat-pipe temperature difference, ΔT , in W/cm². Neon would add $0.071 \Delta T \text{ W/cm}^2$, and argon would add $0.013 \Delta T \text{ W/cm}^2$. Also, the radiant heat transfer is $4.68/200 = 0.0234 \text{ W/cm}^2/^\circ\text{K}$ for the 1900° K - 1700° K embodiment and $2.34/100 = 0.0234 \text{ W/cm}^2/^\circ\text{K}$ for the 1850° K - 1750° K embodiment. Thus, instead of of 4.68 W/cm² for the vacuum 1900° K - 1700° K embodiment, the use of helium would result in $q = (0.0234 + 0.88) 200 = 180.6 \text{ W/cm}^2$. For neon, $q = (0.0234 + 0.071) 200 = 78.9 \text{ W/cm}^2$, and for argon, $q = (0.0234 + 0.013) 200 = 7.3 \text{ W/cm}^2$. Because the requirement of the thermionic converter of the example is about 23.5 W/cm², the heat pipe would reduce thermal power densities for the helium and neon gaps and increase them for the argon and

vacuum gaps.

Instead of 2.34 W/cm^2 for the vacuum $1850^\circ \text{ K} - 1750^\circ \text{ K}$ embodiment, the use of helium results in $q = (0.0234 + 0.88) 100 = 90.3 \text{ W/cm}^2$. The use of neon results in 9.44 W/cm^2 .
5 and argon produces 3.64 W/cm^2 . In this example the heat pipe would reduce the thermal power density for the helium gap and increase it for the neon, argon, and vacuum gaps. Thus, the utilization of electrically non-conducting gases enhances heat transfer between the heat pipes 10 and 18, which would adapt the
10 resulting thermal power densities to the thermionic converter needs.

It is apparent that the heat pipe 10 and 18 have the capability for "stepping up" or "stepping down" thermal power densities. This transforming compensates for the comparatively
15 low thermal power densities through the electrically non-conducting vacuum or argon gap 26 between these two heat pipes or for the high thermal power densities through the helium gap. It is also apparent this effect is modular and can be used repeatedly parallel to transfer the total amount of heat
20 required.

Although the invention has been described relative to exemplary embodiment thereof, it will be understood that variations and modifications can be effected in this embodiment without departing from the spirit of the invention or the scope
25 of the subjoined claims.

AbstractHigh Thermal Power Density Heat Transfer

This invention is directed to transferring heat from an extremely high temperature source to an electrically isolated lower temperature receiver. The invention is particularly concerned with supplying thermal power to a thermionic converter from a nuclear reactor with electric isolation.

Heat from a high temperature heat pipe (10) is transferred through a vacuum or a gap filled with electrically nonconducting gas (26) to a cooler heat pipe (18). The heat pipe (10) is used to cool the nuclear reactor while the heat pipe (18) is connected thermally and electrically to a thermionic converter (22).

If the receiver requires greater thermal power density, geometries are used with larger heat pipe areas for transmitting and receiving energy than the area for conducting the heat to the thermionic converter. In this way the heat pipe capability for increasing thermal power densities compensates for the comparatively low thermal power densities through the electrically non-conducting gap between the two heat pipes.

**ORIGINAL PAGE IS
OF POOR QUALITY**

INVENTOR: JAMES F. MORRIS

EMPLOYER: NASA Lewis Res. Ctr., Cleveland, OH

EVALUATOR: W. Moeckel

SERIAL NO: 202,228

FILING DATE: 10-30-80