

# ROLE OF OPTICAL COMPUTERS IN AERONAUTICAL

## CONTROL APPLICATIONS

Robert J. Baumbick  
NASA Lewis Research Center  
Cleveland, OH 44135

### ABSTRACT

More complex aircraft and mission requirements will require larger, faster digital computers to perform a variety of functions. For adaptive control, controller gains are computed as a function of flight conditions. For multi-state problems, high speed computing is required to perform matrix/vector and matrix/matrix operations in order to compute these controller gains.

Continued safe operation of the plant has to be maintained in the event of sensor failure. Accommodation of sensor failures requires a system math model that operates in real-time. The model, used to calculate an estimate of the failed sensed variable, should ideally be a full nonlinear model. Currently simplified models are used because of computing limitations. Because of the above requirements, research is being done to determine the role that optical computers might play in aircraft control. The optical computer has the potential high speed capability required, especially for matrix/matrix operations. The optical computer also has the potential for handling nonlinear simulations in real-time.

In addition to the potential high speed capability of optical computers, they may also be more compatible with fiber optic signal transmission. Fiber optics offer advantages over conventional wire systems. One attractive feature of fiber-optic systems is immunity to noise generated from other electromagnetic sources and immunity to lightning strikes. Optics also permit the use of passive sensors to measure process variables. No electrical energy need be supplied to the sensor. Complex interfacing between optical sensors and the optical computer may be avoided if the optical sensor outputs can be directly processed by the optical computer.

## Summary

More complex aircraft and mission requirements will require larger, faster digital computers to perform a variety of functions. For adaptive control, controller gains are computed as a function of flight conditions. For multi state problems high speed computing is required to perform matrix/vector and matrix/matrix operations in order to compute these controller gains.

Continued safe operation of the plant has to be maintained in the event of sensor failure. Accommodation of sensor failures requires a system math model that operates in real-time. The model, used to calculate an estimate of the failed sensed variable, should ideally be a full nonlinear model. Currently, simplified models are used because of computing limitations. Because of the above requirements, research is being done to determine the role that optical computers might play in aircraft control. The optical computer has the potential high speed capability required, especially for matrix/matrix operations. The optical computer also has the potential for handling nonlinear simulations in real-time.

In addition to the potential high speed capability of optical computers, they may also be more compatible with fiber optic signal transmission. Fiber optics offers advantages over conventional wire systems. One attractive feature of fiber-optic systems is immunity to noise generated from other electromagnetic sources and immunity to lightning strikes. Optics also permit the use of passive sensors to measure process variables. No electrical energy need be supplied to the sensor. Complex interfacing between optical sensors and the optical computer may be avoided if the optical sensor outputs can be directly processed by the optical computer.

NASA Lewis Research Center is supporting two grants for basic research on optical computing and how it may be used in aeronautical applications. Carnegie-Mellon University is developing a hybrid electro-optic computer capable of performing matrix operations such as inversion, multiplication, etc. This work considers an analog optical computer.

Ohio State University is developing a digital optical processor. This work centers around a liquid crystal light valve which is used to perform various logic operations and arithmetic operations. Both binary and residue arithmetic are being considered for these applications. Residue arithmetic is potentially more attractive because of the inherent parallelism of this type of arithmetic.

The hybrid and digital optical processors both offer potential improvements in computing speed compared to all-electronic processors, but both require innovations in device technology before they can be used in practical applications.

## Introduction

This paper discusses research programs sponsored by NASA Lewis Research Center for work on optical computers. The objective of this research is to determine the role optical computers may play in future aircraft engine systems. Fiber optics are attractive for engine applications because of optics' inherent immunity to electromagnetic interference (EMI) and because optical signals can be safely transmitted through areas that contain explosive materials. A program was undertaken to develop optical sensors for engine control. Optical links were considered to be superior for signal transmissions aboard the aircraft, especially for off-engine mounted control computers. Currently, engine control computers are mounted on the engine. Special environmental packages must be designed to protect the computer from the harsh temperature and vibration environment. Off-engine mounted computers would be located in a more benign environment. Along with the optical sensors and optical transmission lines, optical computers are considered in this future technology program to determine if and how optical computers could be used. Optical computers are considered because of potential speed improvements over conventional processors. Future aircraft computers will be faster and will have a higher capacity to handle the more complex engines of tomorrow. Some of the functions onboard computers might be called on to perform, if the computers could operate in real-time and had the required capacity, are adaptive control, engine condition monitoring, and sensor failure accommodation. For adaptive control the computer must perform vector/matrix and matrix/matrix calculations. These operations are required to calculate optimal controller gains for multi-variable control.

Engine condition monitoring requires an accurate nonlinear simulation of the engine, and this simulation must operate in real-time. Sensor failure accommodation also requires a nonlinear model to provide accurate state estimates of failed sensor states. Real-time simulation of nonlinear systems is, therefore, important for safe, efficient operation.

The optical computer has the potential for high speed operation required for adaptive control and has the potential for handling nonlinear simulations in real-time. Complex interfacing between optical sensors and the optical computer may be avoided if the optical sensor outputs can be directly processed by the optical computer. NASA Lewis Research Center is supporting two grants for basic research into optical computing and how optical computing could be used in aeronautical applications. Carnegie-Mellon University is developing a hybrid electro-optic computer capable of performing matrix operations such as inversion, multiplication, etc. Ohio State University is developing a digital optical processor. A liquid crystal light valve (LCLV) is used as the central computing element. With the LCLV, logic operations and arithmetic operations can be done.

## Hybrid Electro-Optical Processor

Figure 1 illustrates possible steps used in calculating the optimal controller gains for adaptive control. From sensed information about the system to be controlled, a linearized model is developed using various identification techniques. Given a performance index, optimum control gains are calculated for the multivariable system by solving the Matrix Riccati Equation. At present this procedure is carried out on the ground. It would be desirable to do this onboard since the optimum gains could be updated to reflect changes in engine characteristics or variability from engine to engine. To do this onboard would require fast solutions to the Matrix Riccati Equation. Typically, a solution of the Matrix Riccati Equation takes hundreds of msec on an electronic computer. Using an optical computer to perform the matrix operations, solution times of a msec or better are possible.

The Carnegie-Mellon optical vector/matrix multiplier is shown in figure 2. The values of the components of the vector  $x$  are represented by the intensities of the light emitting diodes (LED) or Laser Diodes (LD). The LED outputs are connected to the matrix mask "A" with optical fibers. Variable transmittance of the cells of the "A" matrix represent the values of the elements  $a_{ij}$ . Because the A matrix can be bipolar, scaling and biasing to accommodate bipolar values must be done. These scaled, biased values are the values of the  $a_{ij}$  elements. The product of the intensity and mask cell transmittance are summed and focused on a linear detector array. This operation is performed rapidly on the optical computer because all operations are done in parallel. When combined with a microprocessor, the optical matrix/vector multiplier can be used to iteratively solve equations of the form  $Ax = y$  where  $x$  is unknown (figure 3). A guess is made for the  $x$  vector. A new  $x$  value is calculated, and when the last value of  $x$  and the new value of  $x$  are equal within a prescribed tolerance, the solution converges and the implicit solution  $A^{-1}y = x$  is obtained. The steady-state Matrix Riccati equation can be reduced to the form  $Ax = y$  and solved by this method.

A photograph of the vector/matrix multiplier hardware used in lab demonstrations is shown in figure 4. The LED array shown is sealed with white RTV compound and bolted to the fiberoptic element, matrix mask and detector array. To have any practical application the mask used to represent the "A" matrix must be alterable to accommodate changing values of the elements  $a_{ij}$ . This concept does have the potential for rapid solutions of the Matrix Riccati Equation.

## Digital Optical Processor

A second grant sponsored by NASA Lewis for work in optical computing is with Ohio State University. The objective of this work is to build and demonstrate optical analogs to digital components to perform various combinational and sequential logic functions. The main element used in this work is a liquid crystal light valve. Residue and binary arithmetic are both being considered for use by this optical computer.

The liquid crystal light valve shown in figure 5 operates in a controlled birefringence mode. Birefringence means that the refractive index is different when the polarization is in the direction of the principal axes compared to polarization at right angles to the axis. In the off state the cigar-shaped liquid crystal molecules are parallel to the glass face. This state has finite birefringence. This birefringence is decreased with application of the AC voltage. The molecules tip as a function of the excitation and light input.

Figure 6 illustrates how the LCLV operates. The electrical excitation can be adjusted to either of two values. Zero optical input produces either no change in the read beam or a rotation of  $90^\circ$  in the polarization of the read beam. The intensity of the input light beam is set so the complementary rotation is achieved when the beam is present.

The face<sub>2</sub> of the liquid crystal light valve can operate on approximately 100 000 spots/in<sup>2</sup> (figure 7). Each spot is independent of its neighbors. This enables the LCLV to be used for operating on 2-D arrays of binary data. The use of residue arithmetic with this LCLV will make optimum use of the parallelism of the LCLV. This LCLV, with the extremely high density of spots, has potential for very large data transfer rates.

Ohio State has demonstrated a number of logic functions using the LCLV. Figure 8 illustrates an optical AND operation. The LCLV is biased to produce  $90^\circ$  rotation of polarization with bright input. As long as A and B spots both have bright inputs there is an output. Should either A or B go dark the output goes to zero.

Figure 9 shows an optical latch circuit. The Glan Thompson prism reflects vertically polarized light and transmits horizontally polarized light. The LCLV is biased to produce a  $90^\circ$  rotation of the reflected beam when the input to the back of the LCLV is bright. The latch is configured to load the data input when the clock is bright (high) and to store the input when the clock is dark (low). The stored output  $\bar{Q}$  is the complement of the input; that is, when the input is bright,  $\bar{Q}$  will be dark and vice versa. If both the clock and the input are bright, the input beam will be rotated  $90^\circ$  to vertical polarization and pass through the analyzer to supply a bright signal to the back of the LCLV. The horizontally polarized light from the DC light source will be rotated to vertical polarization upon reflection from the LCLV and will be reflected by the Glan Thompson prism, thus producing a dark output  $\bar{Q}$ . When the clock goes dark, the dark output  $\bar{Q}$  will remain regardless of changes in the input. This occurs because the DC light source will continue to illuminate the back of the LCLV through the feedback loop. Similar reasoning can be used to explain the loading and storage of a dark input which produces a bright output  $\bar{Q}$ .

The LCLV used in these experiments is very slow, taking hundreds of milliseconds to operate. For practical systems the spatial light modulator must operate in msec or better to achieve the high data rates required for real-time computing.

### Concluding Remarks

In summary, future aeronautical control systems will be more complex. Many functions not performed now and many functions done on the ground would better be done onboard if the speed and capacity of the computer were adequate. Among these functions are providing a real-time engine simulation for engine condition monitoring and for sensor failure accommodation. For adaptive control, onboard optimum multivariable control design would be done. For this to be done, rapid solutions of the Matrix Riccati Equation are required. Optical computers show some potential for applications to engine control systems because of their extremely high speed. Large data transfer capabilities and very fast solution of matrix equations are possible. However, much work has to be done in the area of faster spatial light modulators, optical read/write memories, and addressable alterable masks. These technology developments together with integrated optics may result in a practical electro-optic computer that could be used in engine control systems.

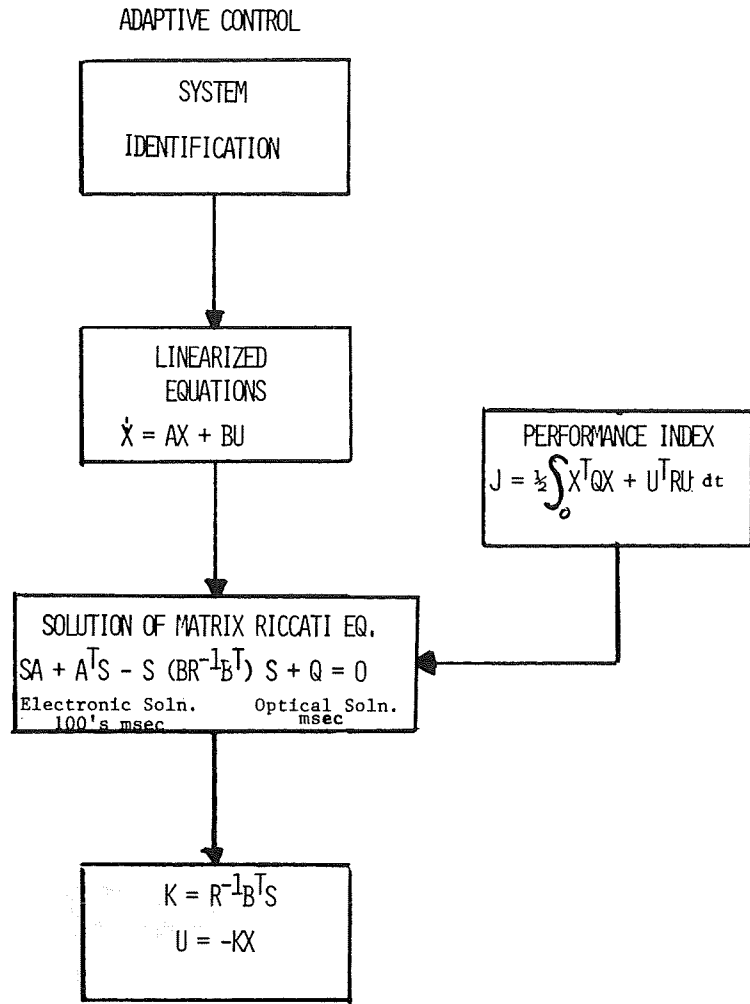

Figure 1.- Sequence of steps in adaptive control application.

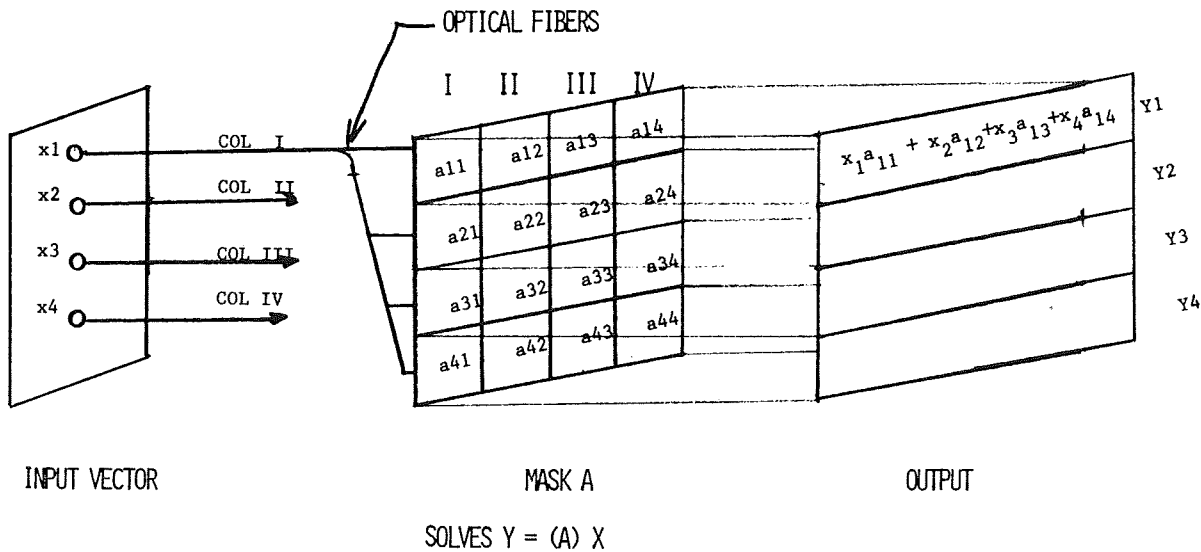

Figure 2.- Vector matrix multiplier (analog model).

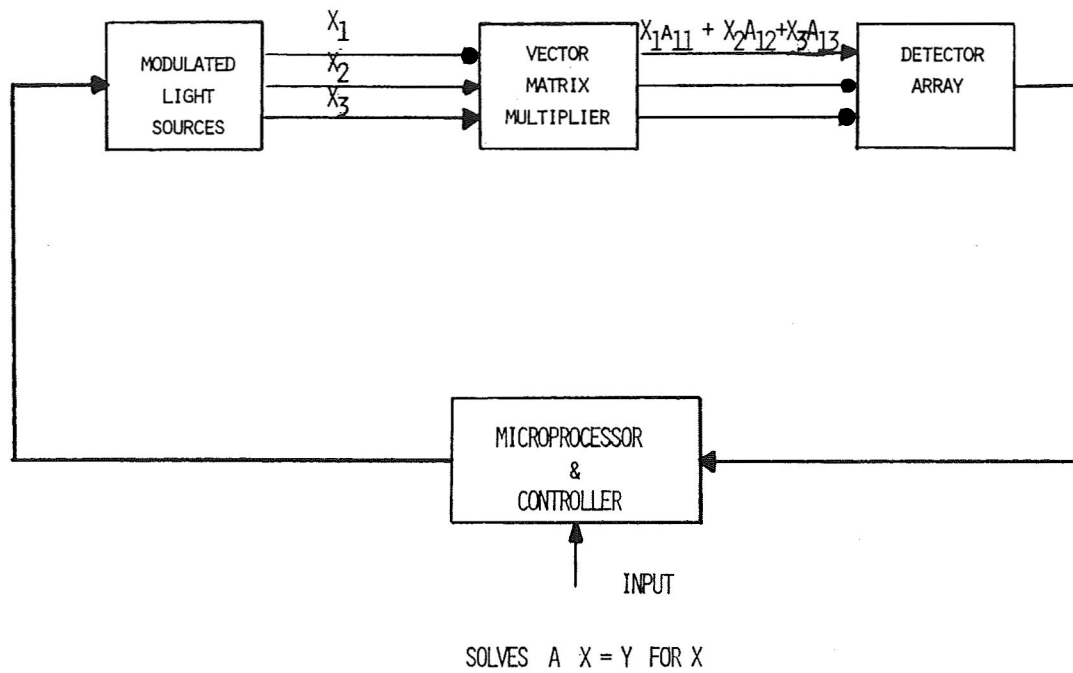

Figure 3.- Solution of vector/matrix equation using iterative optical processor.

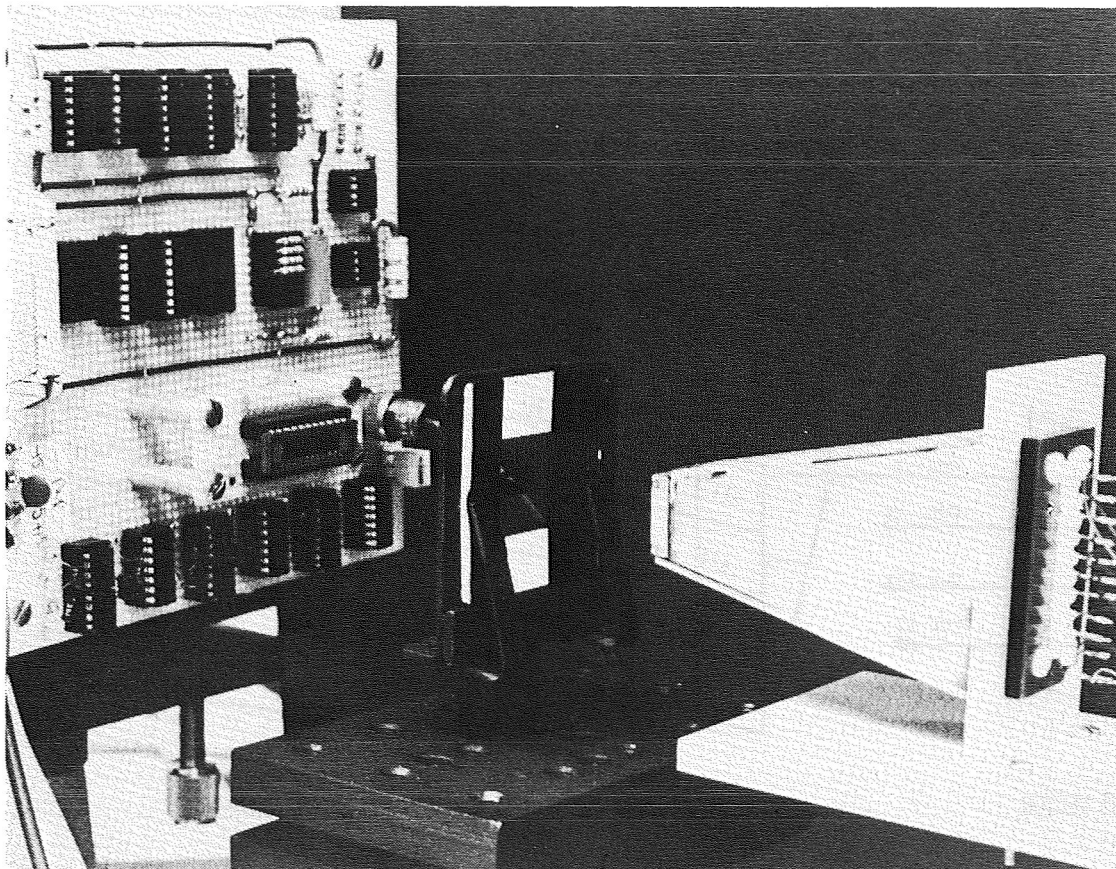

Figure 4.- Iterative optical processor hardware.



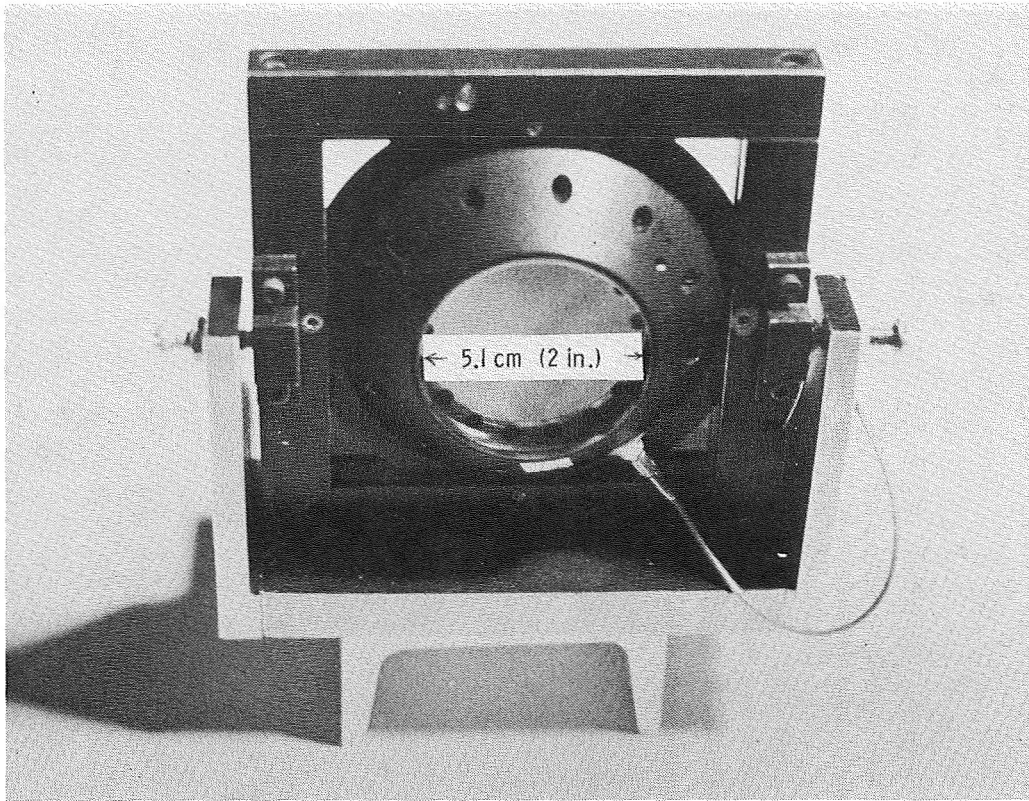
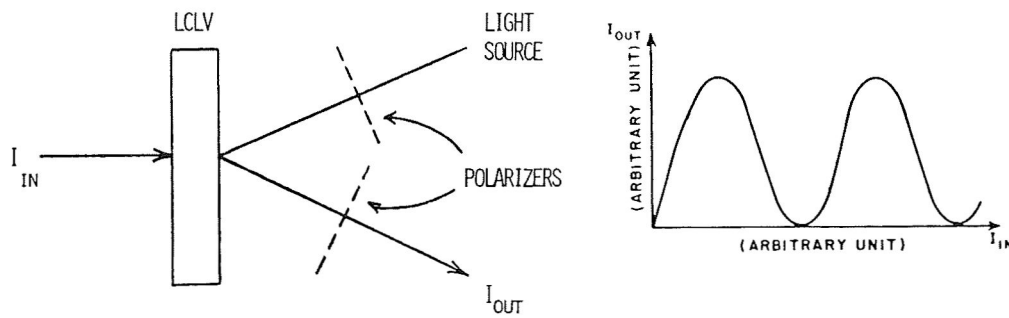

Figure 5.- Liquid crystal light valve.

HUGHES LIQUID CRYSTAL LIGHT VALVE (LCLV)  
SPATIAL LIGHT MODULATOR (SLM)



- o THE LCLV ACTS LIKE A MIRROR WHICH ROTATES THE POLARIZATION OF A REFLECTED BEAM
- o THE AMOUNT OF ROTATION DEPENDS ON  $I_{IN}$
- o THE LCLV CAN OPERATE INDEPENDENTLY ON THOUSANDS OF SEPARATE BEAMS (SPOTS)

Figure 6.- Operation of liquid crystal light valve.

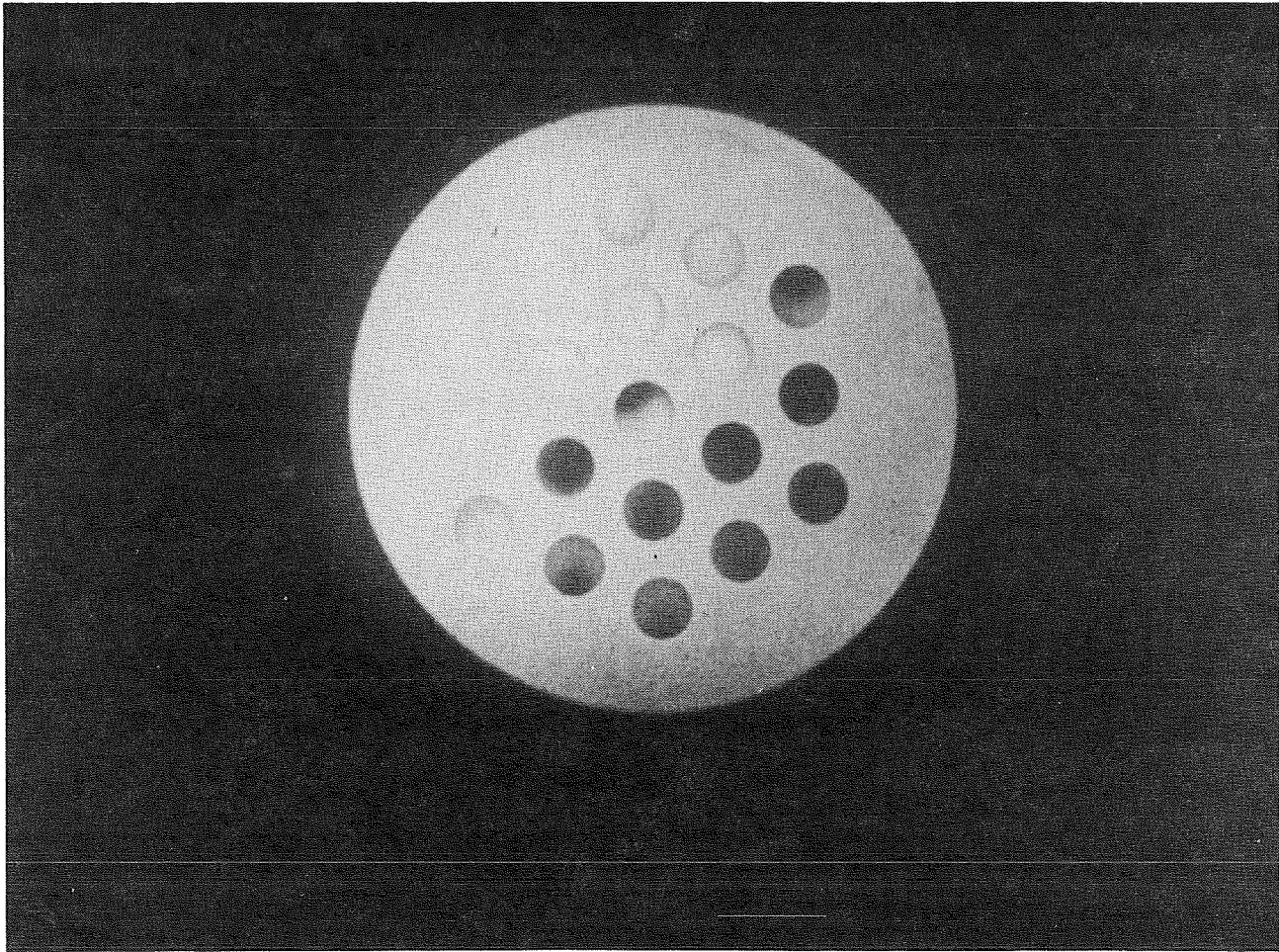

Figure 7.- Liquid crystal light valve face showing individual cells.

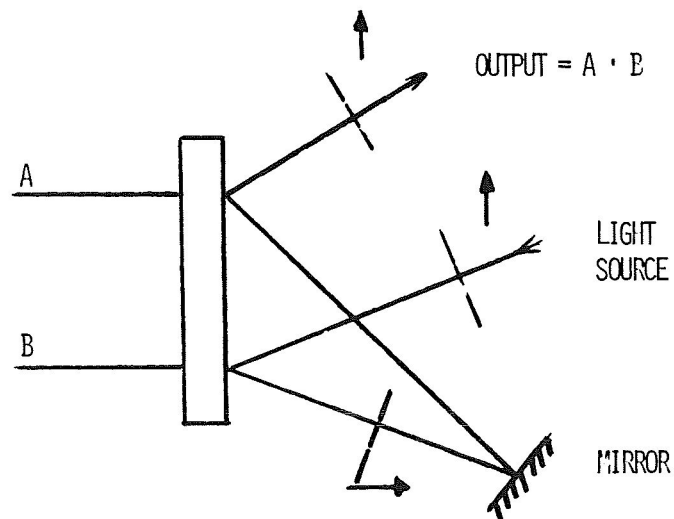

Figure 8.- Logical AND operation using liquid crystal light valve.

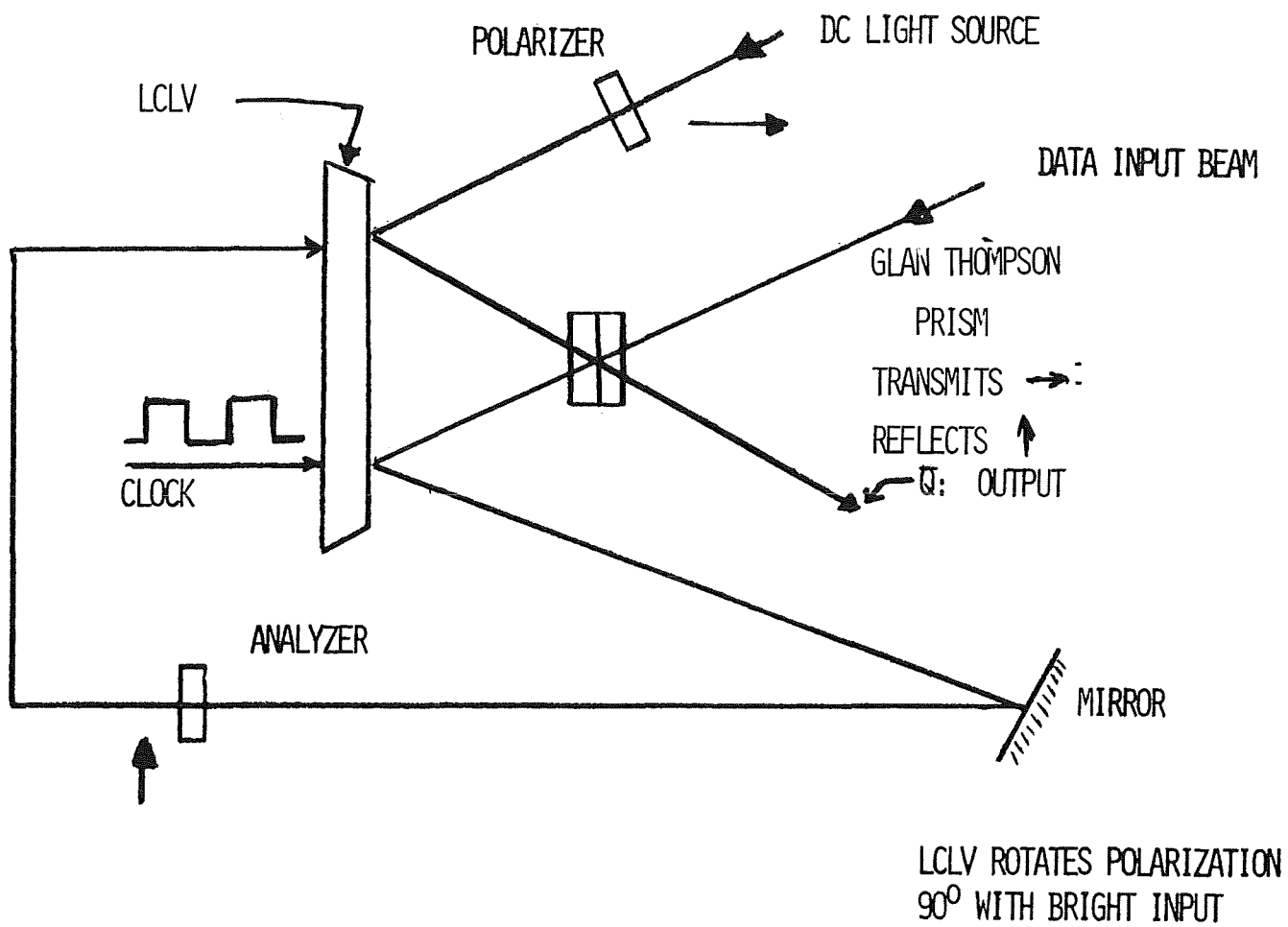

Figure 9.- Optical latch circuit.