

NASA  
Technical  
Paper  
2002

April 1982

NASA  
TP  
2002  
c.1

# Effects of Environment on Microhardness of Magnesium Oxide

Hiroyuki Ishigaki  
and Donald H. Buckley



LOAN COPY RETURN TO  
APWL TECHNICAL LIBRARY  
KIRTLAND AFB, N. M.

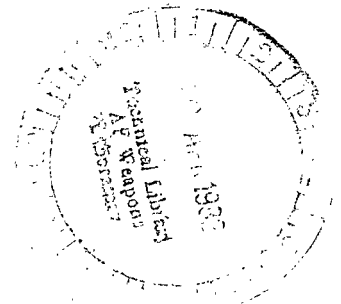

NASA



**NASA  
Technical  
Paper  
2002**

1982

# Effects of Environment on Microhardness of Magnesium Oxide

Hiroyuki Ishigaki  
and Donald H. Buckley  
*Lewis Research Center  
Cleveland, Ohio*

**NASA**

National Aeronautics  
and Space Administration

Scientific and Technical  
Information Branch

## Summary

An investigation was conducted to determine the influence of environment on the micro-Vickers hardness of magnesium oxide single crystals. The indentation tests were conducted on the {100} plane of magnesium oxide, and the indentation diagonals were in  $\langle 100 \rangle$  direction. The media in which indentation tests were conducted included air, nitrogen gas, water, mineral oil, mineral oil with various additives, and aqueous solutions of hydrogen chloride or sodium chloride.

The results of the investigation indicate that the sulfur-containing oil additive increased hardness. On the contrary, both the chlorine-containing oil additive and aqueous solutions of hydrogen chloride decreased hardness. Other environments were found to have little effect on micro-Vickers hardness. The transition of deformation modes from ductile to brittle deformation was not affected by the environment. Mechanically polished surfaces showed larger indentation creep than did as-cleaved surfaces.

## Introduction

Material studies have indicated that chemically active environments can markedly influence the deformation of solids (refs. 1 to 10). It is well known that the deformation of solids influences adhesion, friction, and wear. Microhardness measurement is one of the techniques used to determine the extent of deformation. Understanding the effects of environment on microhardness will greatly enhance understanding of the influence of environment on adhesion, friction, and wear.

The objective of this investigation was to study the effects of environment on the micro-Vickers hardness of magnesium oxide single crystals. Magnesium oxide was selected as the material to examine for a number of reasons: (1) Its slip and fracture behavior are very well understood, (2) the Rehbinder effect has been observed with it, (3) fresh, atomically clean surfaces can be prepared by cleavage, and (4) it can be used as a bearing material (ref. 11).

Indentation tests were conducted on cleaved {100} surfaces, and the indentation diagonals were in the  $\langle 100 \rangle$  direction. The media in which indentation tests were conducted included air, nitrogen gas, water, mineral oil, mineral oil with various additives, and aqueous solutions of hydrochloride or sodium hydroxide.

## Materials

### Specimen

Arc-melted, single-crystal 99.99-percent-pure magnesium oxide was commercially obtained and was used without further annealing. The crystals used in this investigation, except for those of special notation, were examined in the as-cleaved condition. Test specimens were cleaved and indented in the test environment without being exposed to air.

Magnesium oxide is a highly ionic crystal and has a rock-salt structure. Indentations were made on the {100} cleavage planes. The indentation diagonals were in the  $\langle 100 \rangle$  direction. A sketch of the orientation is shown in figure 1.

### Environments

The test specimens were cleaved and indented in the following environments: mineral oil, nitrogen gas, air, and distilled water. It was expected that the environmental effect of adsorbed water would increase from a low with mineral oil to a high with distilled water.

In the study of the effect of oil additives, indentation tests were conducted in mineral oil containing 2 wt % additive. Table I presents the formulas for the additives: tricresyl phosphate, dibutyl sulfide, chlorooctadecane and oleic acid.

In the study of the effect of the pH value of aqueous solutions, indentation tests were conducted in sodium chloride solutions to which sodium hydroxide or hydrochloride had been added. The pH values were 13.5 and 1.0, respectively.

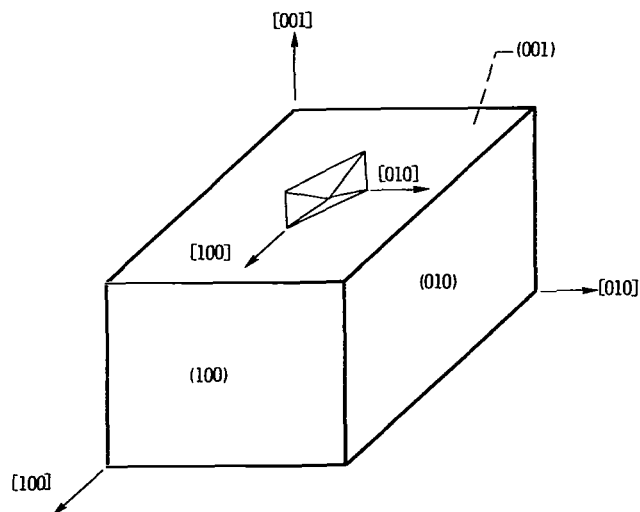

Figure 1. - A sketch of the orientation of indentation.

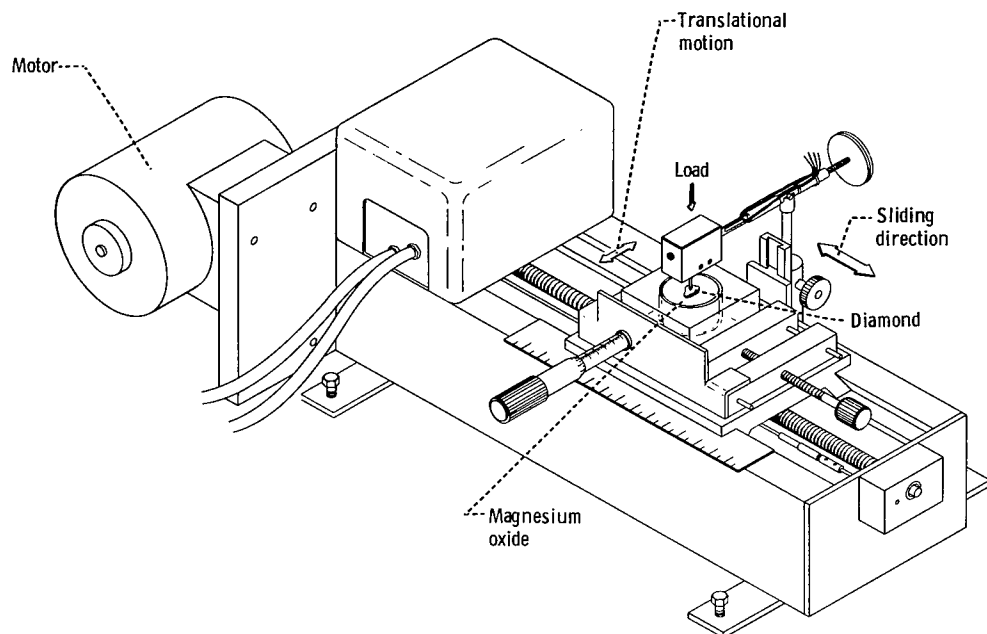

Figure 2. - Sliding friction apparatus.

CD-12079-26

TABLE I. - CHEMICAL FORMULAS OF ADDITIVES

Surface-active species	Formula
Tricresyl phosphate (TCP)	$(C_7H_7O)_3PO$
Dibutyl sulfide (DBS)	$[CH_3(CH_2)_3]_2S$
Chlorooctadecane	$CH_3(CH_2)_{17}Cl$
Oleic acid	$C_{18}H_{34}O_2$

Macmillan, et al. reported (ref. 12) that the dislocation mobility is a minimum in an environment of zero zeta-potential which is obtained in a basic aqueous solution. The zeta-potential is the electrical double-layer surface effect. The pH value for this effect is almost 12.3. To examine the influence of this effect on micro-Vickers hardness, a sodium hydroxide solution with a pH of 12.3 was used in this study.

## Apparatus

Indentation hardness was measured with a micro-Vickers hardness tester. Although the indenting<sup>1</sup> could be done automatically, the vibration generated by the electric motor and gears in the tester introduced significant error for indentation loads less than 1 N. To

avoid this error, indenting was done by hand with the tester fixed on a vibration-free table. A diamond indenter was attached to one end of a precision-balanced rod. The specimen holder was moved vertically by hand until the specimen was in contact with the diamond indenter. Indentation time was 20 sec, except for indentation creep experiments. The apparatus used to measure the friction force between the diamond and the magnesium oxide is shown schematically in figure 2. The beam contained one flat machined normal to the direction of friction application. The end of the rod contained the diamond rider. The load was applied by placing deadweights on a pan on top of the rod. The friction force under an applied load was sensed by strain gages.

## Experimental Results and Discussion

### Basic Properties of Magnesium Oxide

*Effect of indentation load.* - The mode of deformation of a semibrittle material such as magnesium oxide changes from ductile fracture to brittle fracture as the indentation load increases. To determine this transition load and the influence of environment on the transition, indentation tests were conducted at various loads.

The relationship between micro-Vickers hardness measured in air and in mineral oil to the indentation load is shown in figure 3. Each point is an average of 10 measurements. The experimental data scatter is represented by a standard deviation of 3.1 percent of the Vickers hardness number. The micro-Vickers hardness

<sup>1</sup>Adolp I. Buehler, Inc., Micromet hardness tester.

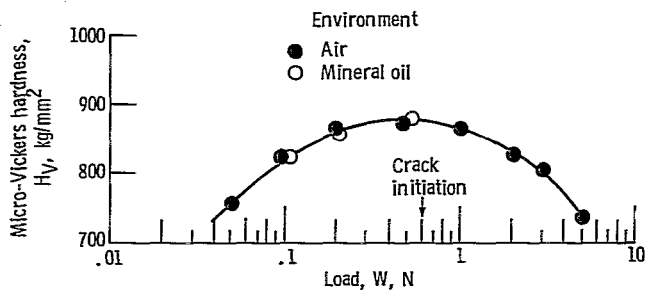

Figure 3. - Micro-Vickers hardness as a function of load.

was greatest when the load was 0.5 N. For loads greater than 0.5 N, hardness decreased as the load increased. This decreasing hardness with increasing loading is caused by the generation of brittle fracture. Indentations at loads near the maximum hardness are shown in figure 4.

At 0.5 N, no crack can be seen on the surface. At 0.7 N, one or two cracks appear on the surface. At 1 N, four cracks were generated on the surface in the  $\langle 110 \rangle$  direction. Cracks were detected by using the scanning electron microscope at high magnification.

For indentation at high loads, brittle fracture under the surface will dominate the deformation process. Optical microscopy revealed the presence of interfaces under the surface of indentation that were generated by cleavages in the bulk material. One example of this bulk cleavage is the white area in figure 5. The domain of brittle fracture in the bulk material (the white area) is much larger than the surface indentation.

To make clear the influence of brittle fracture on plastic deformation in the indentation process, the distribution of dislocation etch pits was measured on the experimental surface. Etch pitting was done with a mixture of 5 parts saturated aqueous  $\text{NH}_4\text{Cl}$ , 1 part concentrated  $\text{H}_2\text{SO}_4$ , and 1 part  $\text{H}_2\text{O}$  (ref. 12). A typical distribution of dislocation etch pits around an indentation is presented in figure 6. The widths of the distribution of edge dislocations  $L$  and of screw dislocations  $l$  were measured. From the results the ratios of the distribution area,  $L^2$  or  $l^2$ , to the load  $W$  were obtained. These ratios are referred to in this report as the relative distribution of dislocation etch pits.

Figure 7 presents the relationship between the relative distribution of dislocation etch pits and load. If both the deformation mode in the indentation process and the hardness value are independent of the indentation load, the area of the distribution of dislocation etch pits should be proportional to the indentation load.

In the higher load range of figure 7, greater than 1 N, the relative distribution decreased with increasing load. In spite of this decrease in the relative distribution, the relative area of indentation, that is, the inverse of micro-Vickers hardness, increased (fig. 3). These results mean

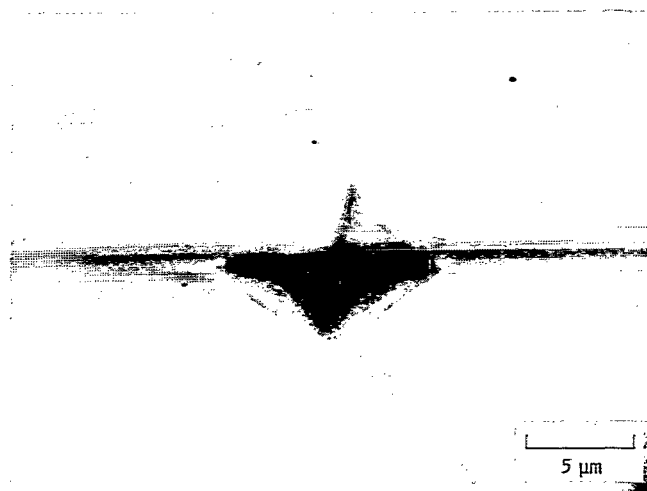

(a) Load, 0.5 N; no cracks.

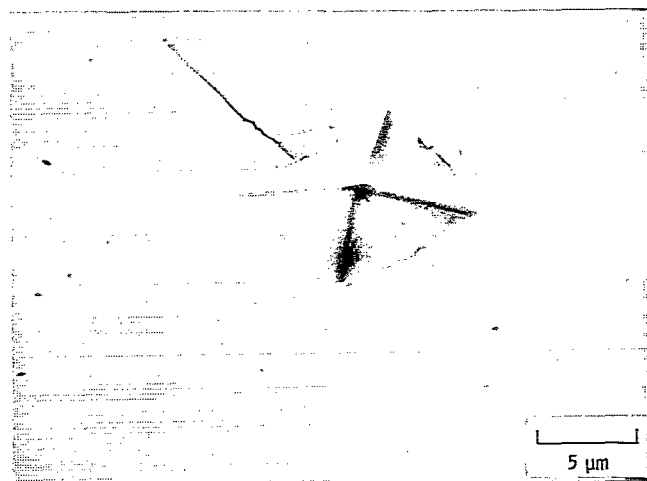

(b) Load, 0.7 N; one crack.



(c) Load, 1 N; four cracks.

Figure 4. - Scanning electron micrographs of cracks around indentation on magnesium oxide (100) surface. Environment, air.

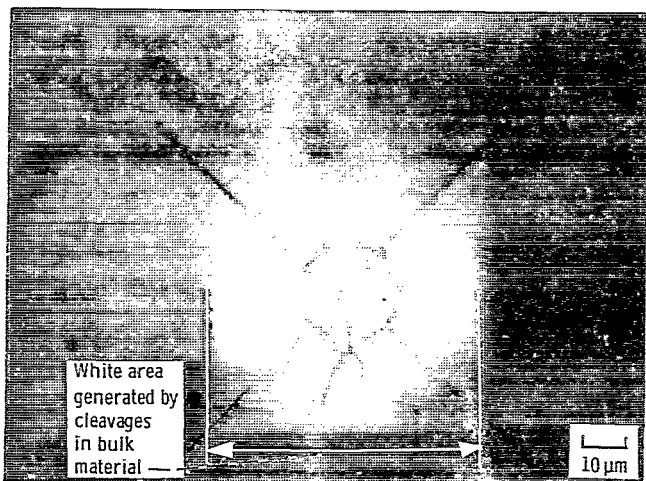

Figure 5. - Cleavages of bulk magnesium oxide in microhardness measurements. Load, 3 N; environment, air.

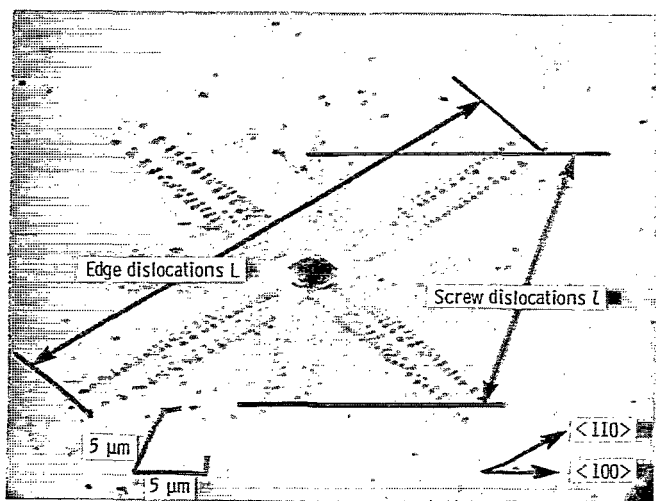

Figure 6. - Distribution of dislocation etch pits. Scanning electron micrograph of indentation on a magnesium oxide single-crystal surface. Environment, air.

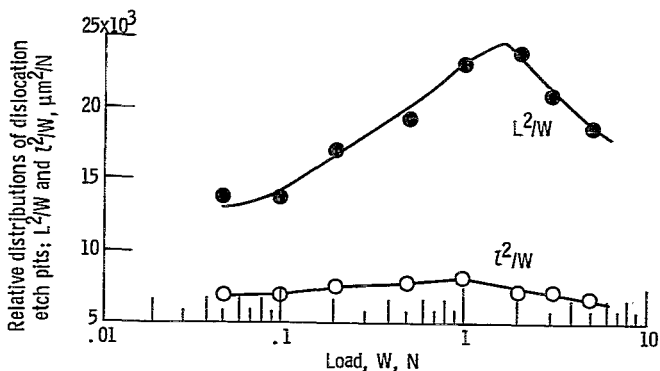

Figure 7. - Relative distributions of dislocation etch pits as a function of load. Environment, air.

that brittle fracture in the bulk material is the dominant effect on micro-Vickers hardness in the higher load range. From these results and the discussion, it is clear that decreasing microhardness with increasing indentation load is caused by the generation of brittle fracture. Beyond the initiation of fracture cracks the measurement is no longer of microhardness, since the energy is no longer being adsorbed in the process of plastic deformation. The data of figure 7 for a load less than 1 N do not agree with dislocation theory for the deformation of solids and must be accounted for by some other mechanism.

The micro-Vickers hardness values were more sensitive to the occurrence of brittle fracture than was the relative distribution of dislocation etch pits because the maximum-hardness load in figure 3 was lower than the load for the maximum relative distribution of dislocation etch pits in figure 7. In addition, the initiation and appearance of cracks on the surface coincided with the beginning of decreasing microhardness (fig. 3).

Judging from the results of hardness measurements, the transition load of deformation modes is about 0.5 N. In experiments described in later sections of this report, the indentation load was 0.1 N. Consequently the mode of deformation was plastic deformation.

The foregoing results were obtained from experiments in air. Experiments in other environments showed a similar tendency in both hardness and relative distribution of dislocation etch pits, and the transition load of the deformation modes from ductile to brittle fracture was not noticeably different from that observed in air.

For loads less than 0.5 N, micro-Vickers hardness increased as the load increased, as shown in figure 3. Westbrook and Jorgensen (ref. 4) observed a similar tendency in experiments with alumina, and they explained it as an effect of adsorbed water. They concluded that the action of adsorbed water in lowering the mechanical properties of alumina was more effective in the near-surface region than in the bulk material and that this caused the observed microhardness increase with increasing load.

In our experiments, however, microhardness showed the same tendency in air as it did in mineral oil, where the surface of magnesium oxide can be expected to have less adsorbed water than in air. This means that adsorbed water has little effect on the increase of hardness with increasing load. Moreover, Upit and Varchenya (ref. 13) indicate that for ionic crystals, such as NaCl, LiF, KBr, and KI, microhardness decreases with increasing load. To clarify the cause for the increase of hardness with increasing load, further investigations are necessary.

**Friction.** - Microhardness increases as the friction between the surfaces of the indenter and flat specimen increases (refs. 14 and 15). Variation in friction with

environment will therefore be an impediment in studying the effect of environment on microhardness. To estimate this effect, the friction between a spherical diamond and a flat surface of magnesium oxide was measured in various environments. The radius of the diamond spherical rider was 200  $\mu\text{m}$ . The load was 0.2 N. Magnesium oxide was cleaved in test environments. The sliding experiments were single pass. Experiments were conducted with a total sliding distance of 4 mm, at a sliding velocity of 0.2 mm/sec, on the {100} plane of magnesium oxide. The sliding direction was  $\langle 001 \rangle$ .

Experimental results are shown in figure 8. A rough estimation of plowing force at the interface obtained by using the formula derived by Bowden and Tabor (ref. 16) gives a plowing component to the friction force of only 5 percent. Therefore the measured friction force is mainly an adhesive force. The coefficient of friction between the surfaces of the pyramidal indenter and the test specimen in the indentation process is then represented by the values in figure 8.

The figure shows little difference between the coefficients of friction in various kinds of environments. Thus there is no need to take into consideration the

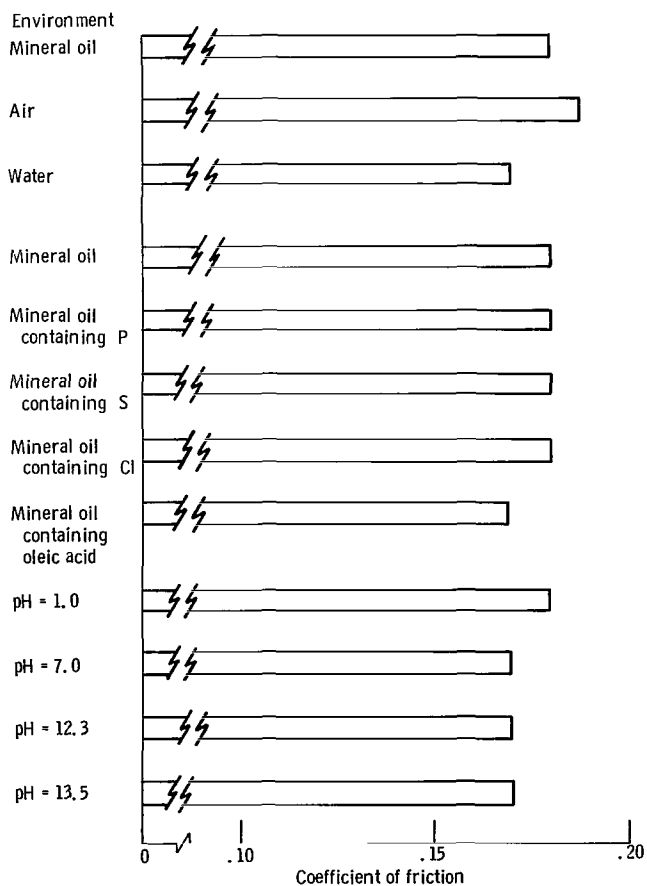

Figure 8. - Effect of environment on friction of a magnesium oxide single-crystal surface.

impediment caused by the variation of friction force in studying the effect of environment on microhardness.

### Effect of Adsorbed Water

The effect of adsorbed water on micro-Vickers hardness is presented in figure 9. The environments in the figure are arranged from top to bottom in the order of increasing adsorption of water on the magnesium oxide surface. Each plot is the average of 10 measurements. It is well known that magnesium oxide reacts with water to form a hydroxide. Therefore water can be expected to exert an influence on micro-Vickers hardness. However, we found no evident effect of water on micro-Vickers hardness.

This result does not agree with others in the literature. Westbrook and Jorgensen (ref. 17) showed that adsorbed water decreased the hardness of magnesium oxide. Dufrane and Glaeser (ref. 11) showed that adsorbed water increased the hardness of magnesium oxide, just the opposite of the result obtained by Westbrook and Jorgensen. The Dufrane and Glaeser result was an extrapolation from experimental results in rolling fatigue and was not derived from a direct measurement of microhardness. It is therefore difficult to compare our result with that of Dufrane and Glaeser.

The results derived from the measurement of micro-Vickers hardness by Westbrook and Jorgensen can be compared with our results directly. They measured the microhardness of a magnesium oxide single crystal that had been finished by mechanical polishing. Polished surfaces show quite different character in indentation deformation, such as indentation creep. The disagreement between our results and those of Westbrook and Jorgensen is caused by the effect of mechanical polishing in their studies. This effect of mechanical polishing is discussed later in the section Effects of Environment on Indentation Creep.

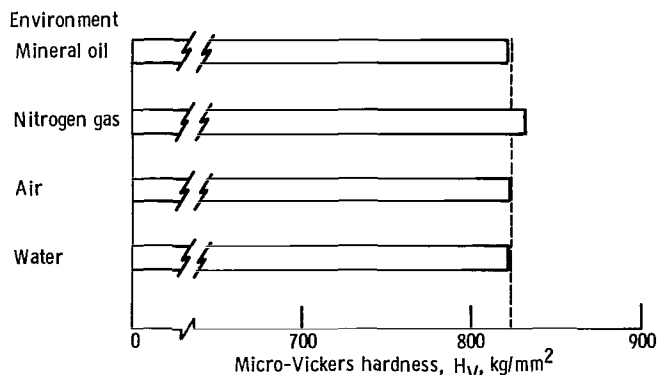

Figure 9. - Effect of adsorbed water on micro-Vickers hardness of a magnesium oxide single-crystal surface.

### Effect of Oil Additives

The effect of oil additives on micro-Vickers hardness is presented in figure 10. The phosphorus-containing additives used in the study and oleic acid had little effect on hardness. A sulfur-containing additive increased the hardness 5.5 percent, and a chlorine-containing additive decreased the hardness 4.5 percent.

The variations in the distribution width of dislocation etch pits are shown in figure 11. It is clear from comparing figures 10 and 11 that the micro-Vickers hardness has a negative correlation with the distribution width of dislocations. Sulfur decreased the distribution width. This means that adsorbed sulfur decreased the mobility of dislocations and thus increased the microhardness. On the contrary, chlorine increased the distribution width. Chlorine can chemically bond to magnesium (e.g.,  $MgCl_2$ ). The chemical bond increased

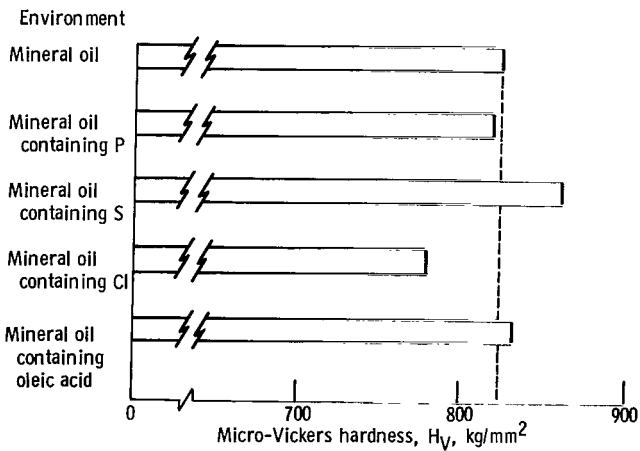

Figure 10. - Effect of additives on micro-Vickers hardness of a magnesium oxide single-crystal surface.

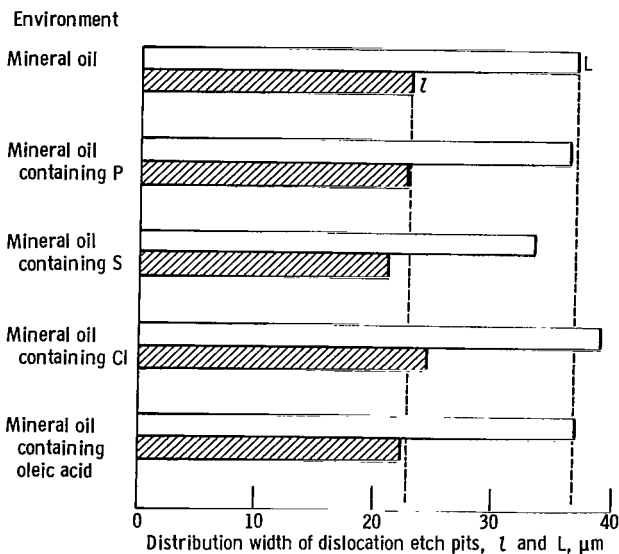

Figure 11. - Effect of additives on distribution width of dislocation etch pits of a magnesium oxide single-crystal surface.

the mobility of dislocations and thus decreased the microhardness.

Sulfides of magnesium have a greater shear strength than chlorides (ref. 18). The greater ease of dislocation motion with the chlorides than with the sulfides may be reflected in this mechanical property and correspondingly in microhardness measurements.

### Effect of pH Value of Aqueous Solutions

The effect of pH on micro-Vickers hardness is indicated in figure 12. In the environment of a strong acid, pH = 1.0, the micro-Vickers hardness shows a lower value. The distribution width of dislocation etch pits is presented in figure 13. The correlation between figures 12 and 13 is similar to that between figures 10 and 11. A strong acid increases the distribution width of edge dislocations and decreases the micro-Vickers hardness. Dislocation etch pits appeared on the surface of magnesium oxide immersed in the strong acid aqueous hydrochloric acid (HCl) without using an etchant. Aqueous HCl itself serves as etchant for magnesium oxide.

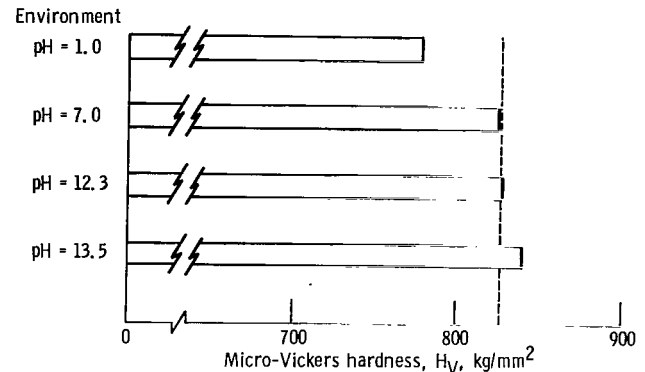

Figure 12. - Effect of pH value on micro-Vickers hardness of magnesium oxide.

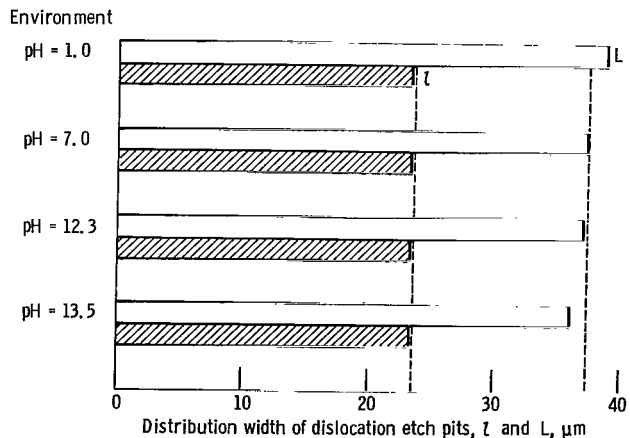

Figure 13. - Effect of pH value on distribution width of dislocation etch pits of magnesium oxide.



The effect of HCl on micro-Vickers hardness is based on two factors. One is that HCl is a solvent for magnesium oxide, and the other is that chlorine can react with magnesium oxide to form a chemical bond ( $MgCl_2$ ). Further experiments will be necessary to isolate these two factors and their effects from each other.

In basic environments the pH value has little influence on micro-Vickers hardness, as indicated in figure 12. Macmillan, et al., made indentation creep tests and measured dislocation mobility (ref. 12). They found that the environment in which the zeta-potential becomes zero, a pH of almost 12.3, gives minimum dislocation mobility, and they concluded that magnesium oxide has a maximum hardness in this environment. In figure 12 a pH of 12.3 does not have an evident effect on micro-Vickers hardness. The effect of zeta-potential, if it exists, is negligibly small.

### Effect of Environment on Indentation Creep

The preceding paragraphs indicate that micro-Vickers hardness has a correlation with dislocation mobility. Dislocation mobility is a function of indentation time and is affected by the environment. It then can be expected that environment will have an effect on indentation creep. The change of hardness with indentation time in air and water is shown in figure 14. Each plot is the average value of five measurements. The reduction of micro-Vickers hardness with indentation time was quite small.

Westbrook and Jorgensen showed a remarkable reduction of the micro-Vickers hardness  $H_V$  of magnesium oxide with indentation time, from  $H_V=600$  (3 sec) to  $H_V=400$  (100 sec), in air (ref. 4). They concluded that the indentation creep was due to the effect of adsorbed water. One of the differences of our experimental condition from their condition was the manner of test specimen preparation. Our specimens were tested as cleaved; their specimens were finished by mechanical polishing. To clarify this difference, we conducted indentation creep tests on test specimens finished by dry polishing with  $Al_2O_3$  powder.

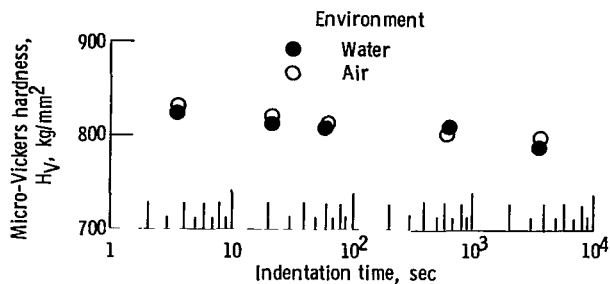

Figure 14. - Indentation creep of as-cleaved surface of magnesium oxide.

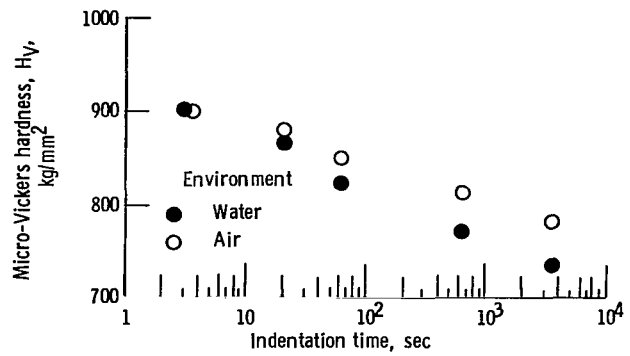

Figure 15. - Indentation creep of mechanically polished surface of magnesium oxide.

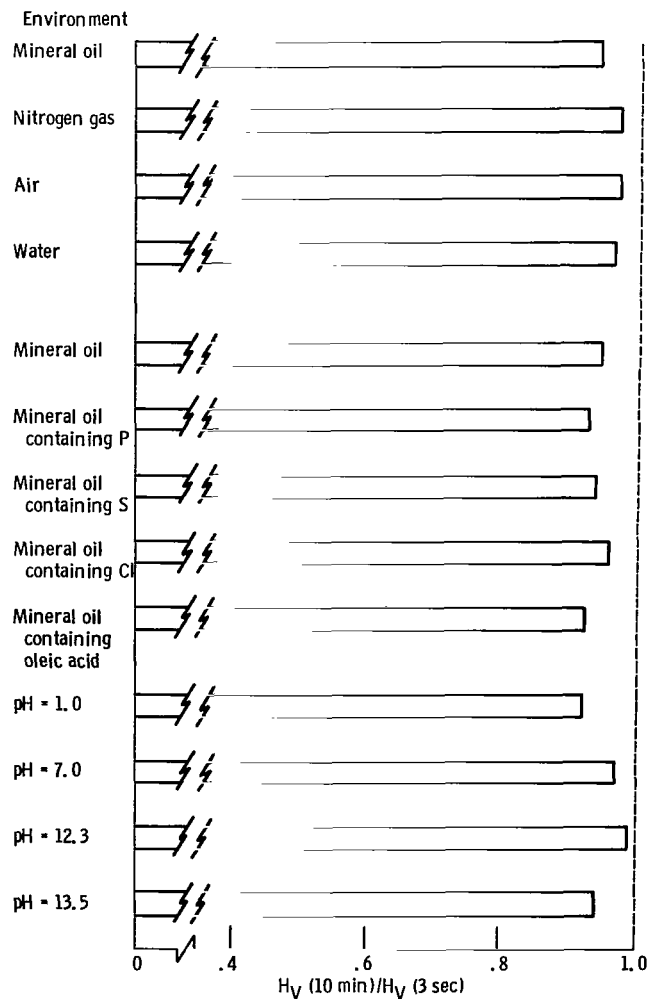

Figure 16. - Effect of environment on indentation creep of magnesium oxide.

The results are shown in figure 15. As compared with the results of figure 14, the reduction of microhardness by indentation creep with the mechanically polished surfaces is evidently large. This means that indentation creep is affected by dislocation density, the density being greater in the mechanically polished specimens. Figure 15 indicates that the reduction of hardness was larger in water than in air. Adsorbed water will release dislocation pileups and will increase the mobility of dislocations. These effects of adsorbed water appeared more strongly for the surface with high dislocation density (i.e., for the surface finished by mechanical polishing). This result makes it clear that the disagreement of our results for the effect of adsorbed water with the results of reference 17 is due to the difference in surface preparation.

The effect of environment on indentation creep is shown in figure 16. Each value is the ratio of an average value of five measurements of micro-Vickers hardness after indenting for 3 sec to an average value after indenting for 10 min.

The figure shows no evident effect of environment on indentation creep. Comparing figure 16 with figures 9, 10, and 12 reveals no correlation between the effects of environment on micro-Vickers hardness and on indentation creep.

## Conclusions

From the micro-Vickers hardness measurement of a magnesium oxide single-crystal {100} surface in various environments, the following conclusions were drawn:

1. The transition load of the deformation mode from ductile to brittle deformation is not affected by environment.
2. Adsorbed water has little effect on the micro-Vickers hardness of the as-cleaved surface.
3. The sulfur-containing additive in mineral oil used herein increases hardness and the chlorine-containing additive decreases hardness.
4. Aqueous solutions of hydrogen chloride decrease hardness.
5. Mechanically polished surfaces show larger indentation creep than as-cleaved surfaces.

Lewis Research Center  
National Aeronautics and Space Administration  
Cleveland, Ohio, October 30, 1981

## References

1. Rehbinder, P. A.; and Shchukin, E. D.: Surface Phenomena in Solids During Deformation and Fracture Processes. Progress in Surface Science, Vol. 3, Pt. 2, S. G. Davison, ed., Pergamon Press, Inc., 1973, pp. 97-188.
2. Ioffe, Adam F.: The Physics of Crystals. L. B. Loeb, ed., McGraw-Hill Book Co., Inc., 1928.
3. Roscoe, R.: The Plastic Deformation of Cadmium Single Crystals. Philos. Mag., vol. 21, 1936, pp. 399-406.
4. Westbrook, J. H.; and Jorgensen, P. J.: Indentation Creep of Solids. Trans. AIME, vol. 233, no. 2, Feb. 1965, pp. 425-428.
5. Westwood, A. R. C.; and Goldheim, D. L.: Occurrence and Mechanism of Rehbinder Effects in CaF<sub>2</sub>. J. Appl. Phys., vol. 39, no. 7, June 1968, pp. 3401-3405.
6. Buckley, D. H.: Effect of Surface Active Media on Friction, Deformation, and Fracture of Calcium Fluoride. NASA TN D-5580, 1969.
7. Johnson, R. M.; and Block, R. J.: The Relation Between Surface Damage and Film Strengthening Effects. Acta Metall., vol. 16, 1968, pp. 831-843.
8. Malin, M.; and Vedam, K.: Ellipsometric Studies of Environment-Sensitive Polish Layer of Glass. J. Appl. Phys., vol. 48, no. 3, Mar. 1977, pp. 1155-1157.
9. Latanision, R. M.: Surface Effects in Crystal Plasticity. Fundamentals of Tribology, N. P. Suh and N. Saka, eds., Massachusetts Institute of Technology Press., 1980, pp. 255-294.
10. Gilman, J. J.: The Mechanism of Surface Effects in Crystal Plasticity. Philos. Mag., vol. 6, no. 61, Jan. 1961, pp. 159-161.
11. Dufrane, K. F.; and Glaeser, W. A.: Study of Rolling-Contact Phenomena in Magnesium Oxide. (Battelle Memorial Inst.; NASA Contract NAS3-6263) NASA CR-72295, 1967.
12. Macmillan, N. H.; Huntington, R. D.; and Westwood, A. R. C.: Relationship Between  $\zeta$ -Potential and Dislocation Mobility. Philos. Mag., vol. 28, no. 4, Oct. 1973, pp. 923-931.
13. Upit, G. P.; and Varchenya, S. A.: The Size Effect on the Hardness of Single Crystals. The Science of Hardness Testing and Its Research Applications, J. H. Westbrook and H. Conrad, eds., American Soc. for Metals, 1973, pp. 135-146.
14. Tabor, D.: Hardness of Metals. Oxford University Press, London, 1951, p. 37.
15. Beeuwkes, R., Jr.; Chait, R.; and Lin, H.H.: The Practical Determination of Flow Curves by Indentation Hardness Methods. The Science of Hardness Testing and Its Research Applications, J. H. Westbrook and H. Conrad, eds., American Soc. for Metals, 1973, pp. 75-90.
16. Bowden, F. P. and Tabor, D.: The Friction and Lubrication of Solids. Oxford University Press, London, 1950, p. 92.
17. Westbrook, J. H.; and Jorgensen, P. J.: Effects of Adsorbed Water on Indentation Hardness Anisotropy in Crystals. Anisotropy in Single-Crystal Refractory Compounds, Vol. 2, F. W. Vahldiek and S. A. Mersol, eds., Plenum Press, 1968, pp. 353-366.
18. Bridgman, P. W.: Shearing Phenomena at High Pressures, Particularly in Inorganic Compounds. Proc. Am. Acad. Arts Sci., vol. 71, no. 9, 1937, pp. 387-460.

1. Report No. NASA TP-2002	2. Government Accession No.	3. Recipient's Catalog No.
4. Title and Subtitle <b>EFFECTS OF ENVIRONMENT ON MICROHARDNESS OF MAGNESIUM OXIDE</b>		5. Report Date April 1982
7. Author(s) <b>Hiroyuki Ishigaki and Donald H. Buckley</b>		6. Performing Organization Code <b>506-53-12</b>
9. Performing Organization Name and Address <b>Lewis Research Center National Aeronautics and Space Administration Cleveland, Ohio 44135</b>		8. Performing Organization Report No. <b>E-916</b>
12. Sponsoring Agency Name and Address <b>National Aeronautics and Space Administration Washington, D. C. 20546</b>		10. Work Unit No.
15. Supplementary Notes <b>Hiroyuki Ishigaki, University of Osaka Prefecture, Osaka, Japan, and National Research Council - NASA Research Associate; Donald H. Buckley, Lewis Research Center.</b>		11. Contract or Grant No.
16. Abstract <p>Micro-Vickers hardness measurements of magnesium oxide single crystals were conducted in various environments. These environments included air, nitrogen gas, water, mineral oil with or without various additives, and aqueous solutions with various pH values. Indentations were made on the {100} plane with the diagonals of the indentation in the &lt;100&gt; direction. The results indicate that a sulfur-containing additive in mineral oil increased hardness, a chlorine-containing additive in mineral oil decreased hardness, and aqueous solutions of hydrogen chloride decreased hardness. Other environments were found to have little effect on hardness. Mechanically polished surfaces showed larger indentation creep than did as-cleaved surfaces.</p>		13. Type of Report and Period Covered <b>Technical Paper</b>
17. Key Words (Suggested by Author(s)) <b>Microhardness Magnesium oxide Indentation creep Environment</b>		14. Sponsoring Agency Code
18. Distribution Statement <b>Unclassified - unlimited STAR Category 27</b>		
19. Security Classif. (of this report) <b>Unclassified</b>	20. Security Classif. (of this page) <b>Unclassified</b>	21. No. of Pages <b>10</b>
		22. Price* <b>A02</b>

National Aeronautics and  
Space Administration

SPECIAL FOURTH CLASS MAIL  
BOOK

Postage and Fees Paid  
National Aeronautics and  
Space Administration  
NASA-451



Washington, D.C.  
20546

Official Business

Penalty for Private Use, \$300

9 1 19,0, 010202 30070305  
DEPT OF THE AIR FORCE  
ARMS AND AMMUNITION LABORATORY  
ATTN: TECHNICAL LIBRARY (SUL)  
CIRLAND AFB TX 77117

**NASA**

POSTMASTER: If Undeliverable (Section 158  
Postal Manual) Do Not Return

---