

TRANSIENT THERMAL ANALYSIS OF A TITANIUM MULTIWALL THERMAL PROTECTION SYSTEM

M. L. Blosser
NASA Langley Research Center
Hampton, Virginia

INTRODUCTION

(Figure 1)

This paper demonstrates the application of the SPAR Thermal Analyzer (ref. 1) to the thermal analysis of a thermal protection system concept. Thermal analysis is especially useful in the concept design and development stages to provide a basis for design and design modification decisions.

The titanium multiwall thermal protection system concept (ref. 2) consists of alternate flat and dimpled sheets which are joined together at the crests of the dimples and formed into 30 cm by 30 cm (12 in. by 12 in.) tiles as shown in the figure. The tiles are mechanically attached to the structure. The complex tile geometry complicates thermal analysis. Three modes of heat transfer must be considered: conduction through the gas inside the tile, conduction through the metal, and radiation between the various layers. The voids between the dimpled and flat sheets were designed to be small enough so that natural convection is insignificant (e.g., Grashof number < 1000).

A two step approach was used in the thermal analysis of the multiwall thermal protection system. First, an effective normal (through-the-thickness) thermal conductivity was obtained from a steady state analysis using a detailed SPAR finite element model of a small symmetric section of the multiwall tile. This effective conductivity was then used in simple one-dimensional finite element models for preliminary analysis of several transient heat transfer problems. The model used to determine the effective conductivity is shown on the next figure.

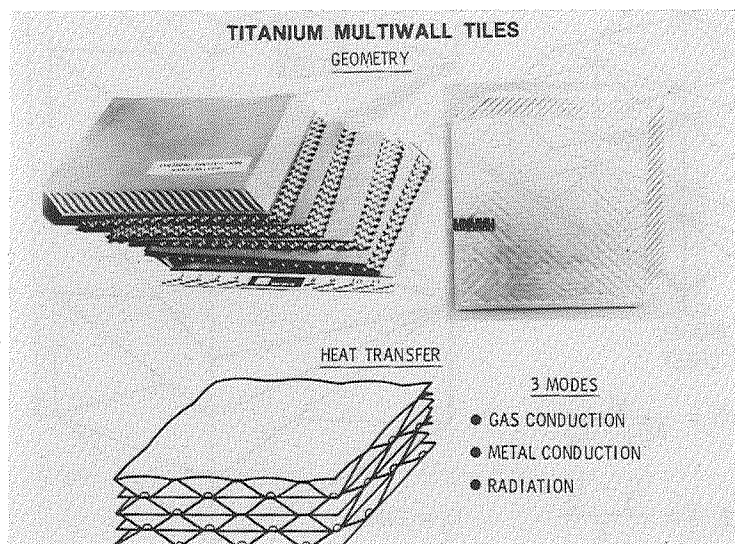

SPAR FINITE ELEMENT MODEL

(Figure 2)

An effective normal thermal conductivity for the 1.75 cm (0.688 in.) thick multiwall tile, shown in the figure, was calculated using a steady-state SPAR finite element analysis. Each dimple of the simplified model of a dimpled sheet, shown on the left of the figure, is represented by eight triangular areas. Each of the eight triangular areas is symmetrical with respect to the heat transfer through the tile; that is, each of the three sides is adiabatic. Therefore, heat transfer through the tile was analyzed with the prism shaped model shown on the right. The upper triangular surface of this model is only 0.20 cm² (0.031 in²). The model contains 333 nodes, 288 metal conduction elements, 264 air conduction elements, and 512 radiation elements. On each of the horizontal and inclined planes of the model, which represent the flat and dimpled sheets respectively, 32 two-dimensional metal conduction elements are arranged as illustrated on the upper surface of the model. Three-dimensional air conduction elements fill the space between the planes of the model, as indicated by the typical element shown. Radiation elements are super-imposed on each side of the metal conduction elements. One element accounts for radiation to and from the upper surface of the metal sheet and the other accounts for radiation to and from the lower surface. Radiation view-factors for the radiation elements were calculated using the general purpose radiation computer program TRASYS II (ref. 3).

The temperature of the bottom surface of the model was held constant and a heating rate, q , was applied to the upper surface. The computed average temperature of the upper surface was used in the standard heat conduction formula, shown on the left of the figure, to calculate an effective conductivity. The results of the calculations are shown in the next figure.

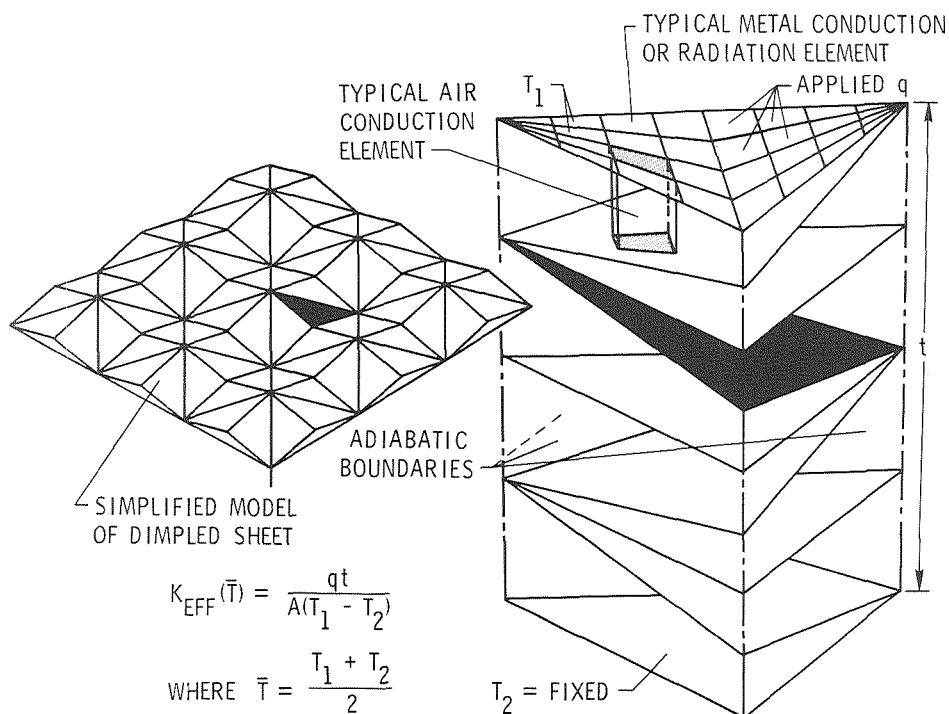

EFFECTIVE THERMAL CONDUCTIVITY

(Figure 3)

This figure shows a comparison between the calculated effective thermal conductivity and the measured thermal conductivity taken from reference 4. The conductivity calculated using SPAR shows good agreement with test data for the same multiwall tile thickness.

The contribution of each mode of heat transfer is also shown. Radiation and gas conduction are the major modes of heat transfer, with radiation becoming the dominant mode at higher temperature. Metal conduction contributes relatively little to the total conductivity of the tile. Because each component was calculated independently, the coupling between the modes of heat transfer was not accounted for. Therefore, the sum of the components is slightly greater than the total conductivity.

The next figure shows an example of the use of this effective conductivity in a simplified transient finite element analysis.

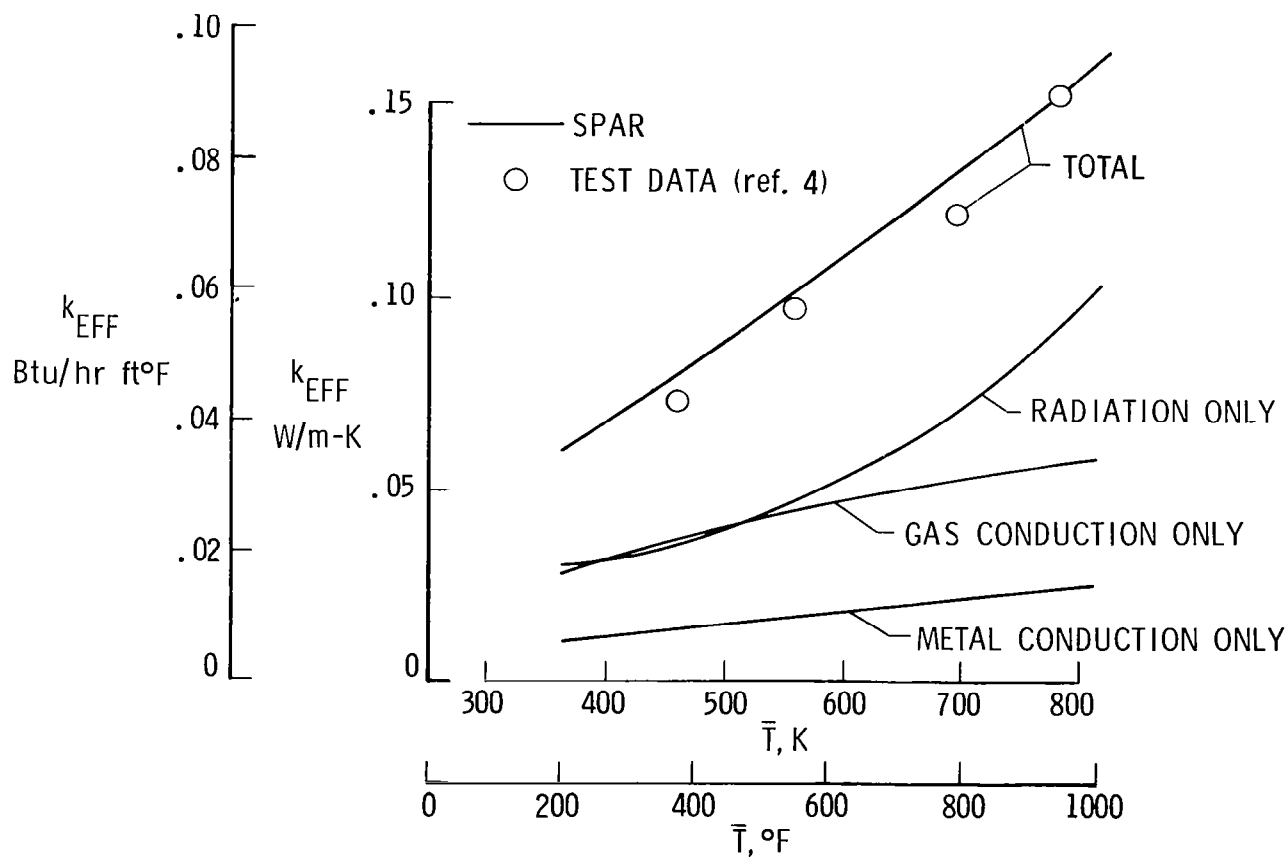

MODEL FOR TRANSIENT 1-D THERMAL ANALYSIS

(Figure 4)

The cross-section on the left of the figure represents a section through the center of a multiwall tile, including the underlying air gap and aluminum structure. The simple, one-dimensional, finite element model, shown to the right of the figure, was used in a SPAR preliminary transient thermal analysis. The model consisted of only 4 nodes and had 3 one-dimensional conduction elements and 2 point radiation elements. The total heat transfer through the multiwall tile was represented by a single 1-D conduction element which was assigned the temperature dependent effective conductivity shown in figure 3. Conduction through the air gap and aluminum was represented by 1-D conduction elements. Radiation across the air gap was accounted for by point radiation elements. Conduction across the air gap is dependent on the thickness of the gap. A temperature history, representative of the design entry thermal environment at Shuttle body point 3140 (a location on the upper center near the windows), was applied to the outer multiwall tile surface. No heat loss was allowed from the lower surface of the structure.

A temperature difference through the thickness of the multiwall tile will cause the tile to bow. The resulting change in air gap thickness was accounted for in the model by proportionately changing the conductivity of the air gap as a function of time. Thermal bowing of multiwall tiles is explained further in the next figure.

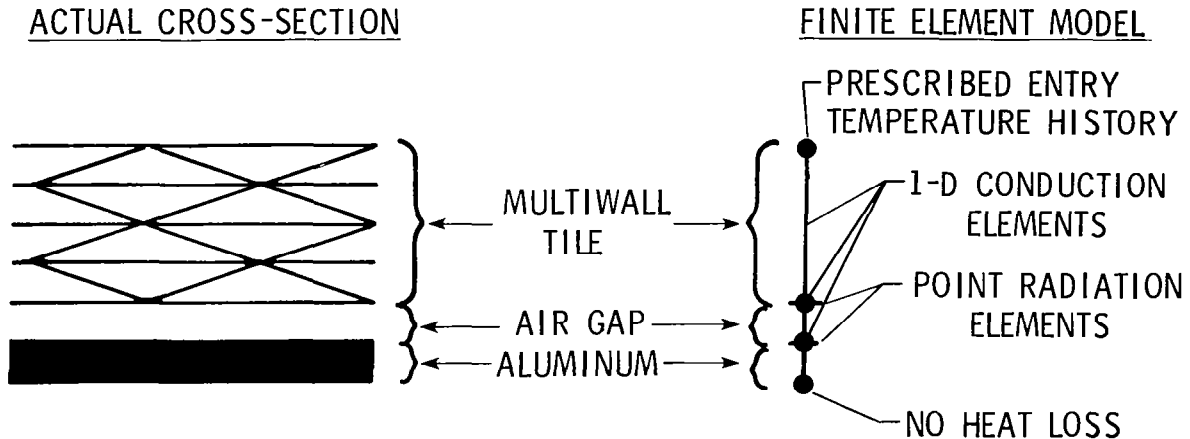

- 4 NODES
- EFFECTIVE CONDUCTIVITY ACCOUNTS FOR HEAT TRANSFER THROUGH MULTIWALL
- TIME-VARYING CONDUCTIVITY USED IN AIR GAP TO SIMULATE EFFECTS OF THERMAL BOWING OF TILE

THERMAL BOWING OF MULTIWALL TILE

(Figure 5)

This figure shows the amount of thermal bowing calculated using temperatures measured during transient heating tests. Two multiwall tiles, shown in the figure, were realistically attached to a well insulated aluminum plate and were subjected to radiant heating which simulated the entry thermal environment at body point 3140. The tiles were instrumented with thermocouples to measure the temperature histories at various locations on the tiles and underlying aluminum. A more complete description of the tests is given in reference 5.

Large differences between backface temperatures measured at the center of the tiles and those measured toward the edges suggested that thermal deformations may have had a significant effect on the thermal performance of the tiles. Temperatures measured at the center of the upper surface (T_1) and lower surface (T_2) of the tile were used to calculate the change in air gap thickness due to thermal bowing as a function of time. The calculated variation of the thickness of the air gap as a function of time is shown in the figure. As previously mentioned, the conductivity, rather than the length of the air gap conduction element, was varied to account for the effects of thermal bowing. The next figure shows the results of the transient analysis.

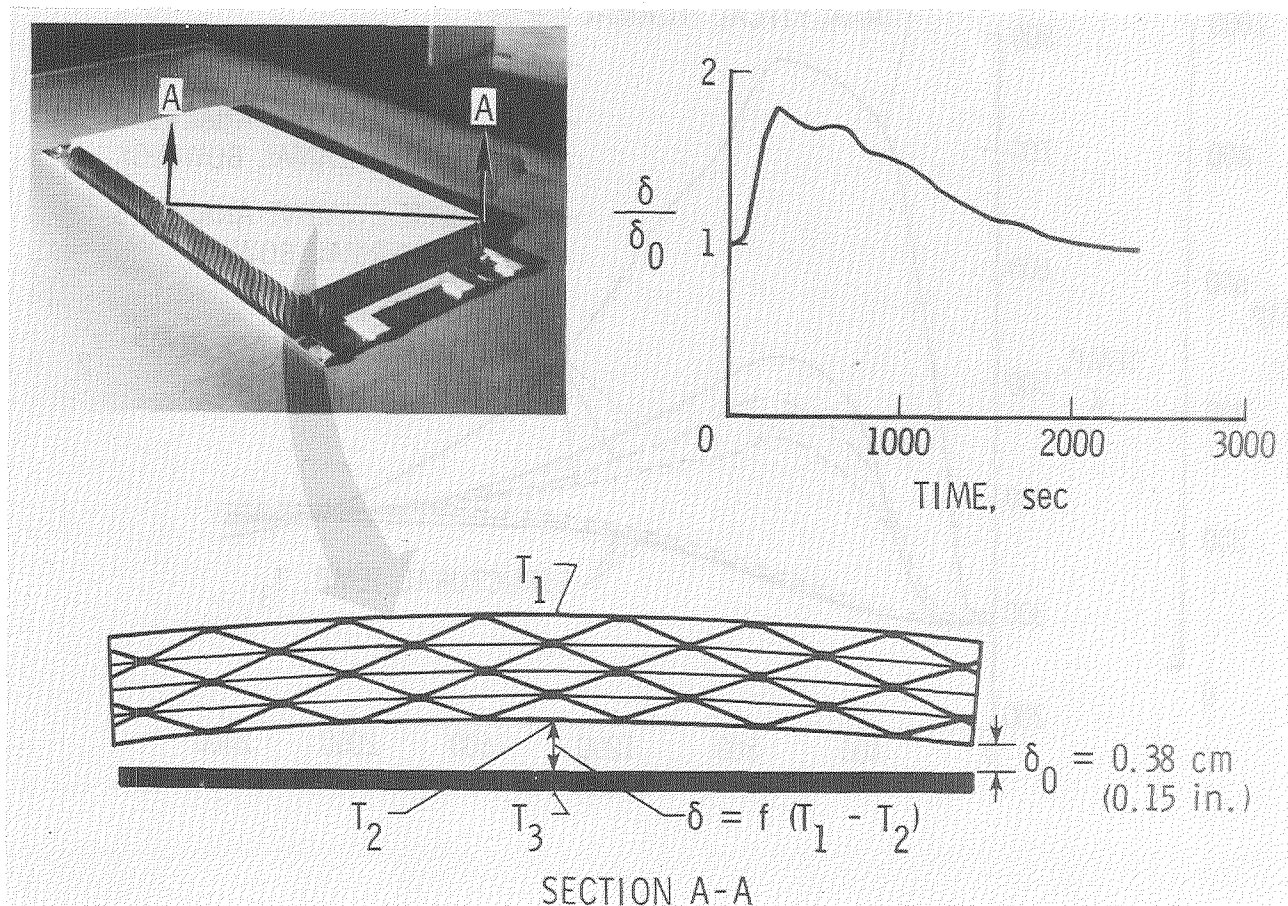

TRANSIENT RESPONSE OF MULTIWALL TILE -
1-D SPAR FINITE ELEMENT ANALYSIS

(Figure 6)

The figure shows a comparison between temperature histories calculated with the one-dimensional SPAR analysis and temperature histories measured during the two-tile radiant heating test. The measured surface temperature history, T_1 , was applied to the surface of the finite element model. Temperatures were calculated both with and without accounting for the effect of thermal bowing. The analysis in which the effects of thermal bowing were neglected slightly overpredicted the structural temperature, T_3 , and significantly underpredicted the temperature of the backface of the multiwall tile, T_2 . When the effect of thermal bowing was included in the analysis the agreement was significantly improved. The temperature of the multiwall tile backface, T_2 , is still underpredicted but there is good agreement between the calculated and measured structural temperatures.

The next figure introduces another problem for which this simple one-dimensional analysis was used.

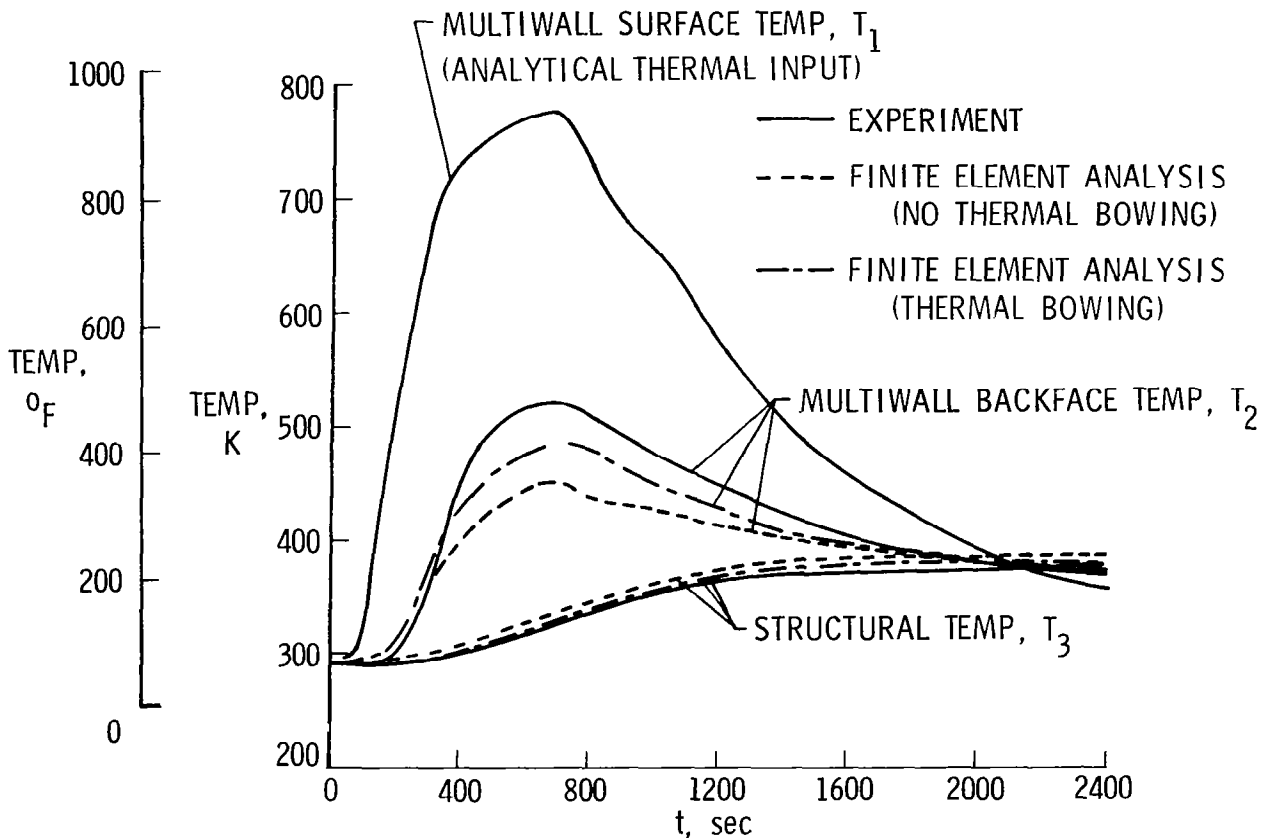

PRELIMINARY THERMAL ANALYSIS IN SUPPORT OF ORBITER
EXPERIMENT OF TITANIUM MULTIWALL

(Figure 7)

As a part of a proposed Orbiter Experiments Program (OEX) the LRSI ceramic tiles on a 2.3 m^2 (25 ft^2) area on the Orbiter will be replaced by titanium multiwall tiles. Thermal analysis was required to determine if the present titanium multiwall tiles, designed for a different location on the Orbiter, would adequately protect the area being considered for the OEX equipment.

A simple one-dimensional SPAR finite element model, similar to the one previously described, was used for the transient thermal analysis at each of the six body points (BP) shown. Although several of these body points were located on the special RSI interface tiles, all body points were assumed to be located at the center of a multiwall tile so that the simple 1-D analysis could be used. For this analysis, thermal bowing was not considered and predicted heating rate histories were used as thermal inputs. A surface emissivity of 0.8 (representative of the surface coating on a multiwall tile) was used. The maximum structural temperature was calculated for each location. The temperatures which are shown on the figure were all below the maximum design temperature of 450 K (350°F). The calculated temperatures are considered to be conservative (high) since this analysis procedure has been shown to overpredict the structural temperature, especially when thermal bowing is not considered. Therefore, this preliminary analysis indicates that the present titanium multiwall tiles will adequately protect the Orbiter structure for this OEX experiment.

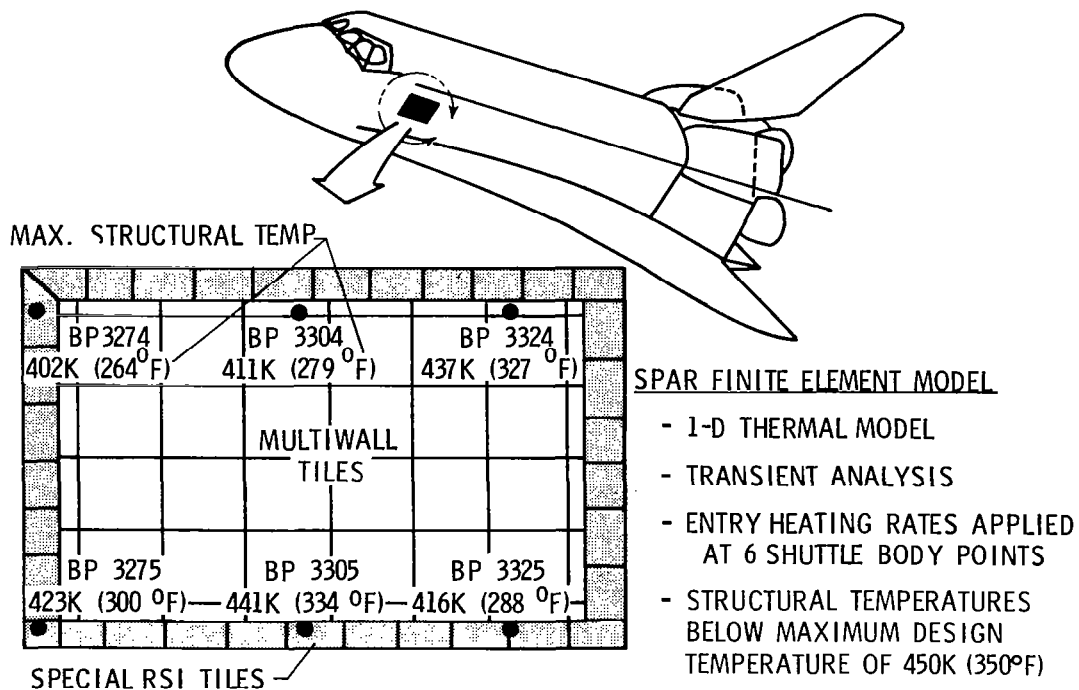

ANALYSIS OF EVACUATED MULTIWALL WITH 2-D SPAR FINITE ELEMENT MODEL

(Figure 8)

Since gas conduction is a major component of the heat transfer through multiwall tile (see fig. 3) the thermal performance of a multiwall tile can be greatly enhanced if the tile is evacuated. However, the pressure must be maintained at less than 10^{-4} mm of mercury to achieve this improvement, and the reliability of a multiwall tile to maintain such a high vacuum is a concern. To determine the effect of loss of vacuum, an evacuated multiwall tile array with a single tile which lost vacuum, as shown in the figure, was considered.

A simplified, two-dimensional SPAR finite element model was used to estimate the increase in structural temperature resulting from the loss of vacuum in one tile of an evacuated multiwall array. The model, shown in the figure, represents a wedge-shaped section with its sharp edge at the center of the unevacuated tile and extending the width of the neighboring evacuated tile. By modelling this wedge-shaped region, a 2-D model can be used to approximate a 3-D structure. The multiwall tile, air gap, and aluminum structure were modelled with 2D conduction elements. Element thicknesses were varied, as shown schematically, to account for 3-D heat diffusion. Radiation across the horizontal air gap was neglected because experience with the 1-D model, shown in figure 4, indicates that accounting for the radiation would have greatly complicated the analysis without significantly affecting the calculated structural temperatures. Radiation across the vertical air gap was neglected for simplicity.

In the normal direction the conductivity used for the evacuated multiwall tile was determined from figure 3 by subtracting the gas component from the total conductivity. The lateral conductance of the multiwall tile was assumed equivalent to that of the metal sheets because the contribution of air conduction was calculated to be negligible in comparison, and lateral heat transfer due to radiation was assumed to be negligible. The lateral conductance was approximately an order of magnitude higher than the transverse conductance.

Calculations were made for four different cases. In all cases the lower surface of the aluminum structure was assumed adiabatic. The first three cases had the prescribed entry temperature history of body point 3140 applied to the multiwall tile surface. For the first case all of the multiwall tiles were assumed unevacuated to determine the maximum structural temperature under an unevacuated array. In the second case the multiwall tiles were assumed to be evacuated to determine the maximum structural temperature under an evacuated array. For the third case, one multiwall tile was assumed unevacuated and the surrounding tiles were assumed evacuated to determine how the added energy absorbed due to vacuum loss in one tile diffused through the aluminum structure.

The purpose of the fourth case was to determine if a tile which had lost vacuum could be easily detected. Starting with the temperature distribution at landing, the surface of the multiwall was cooled by forced convection to ambient temperature, representative of a 5 km/hr (3 mph) wind, and the resulting surface temperature difference between evacuated and unevacuated tiles was computed. The results of these four cases are shown on the next figure.

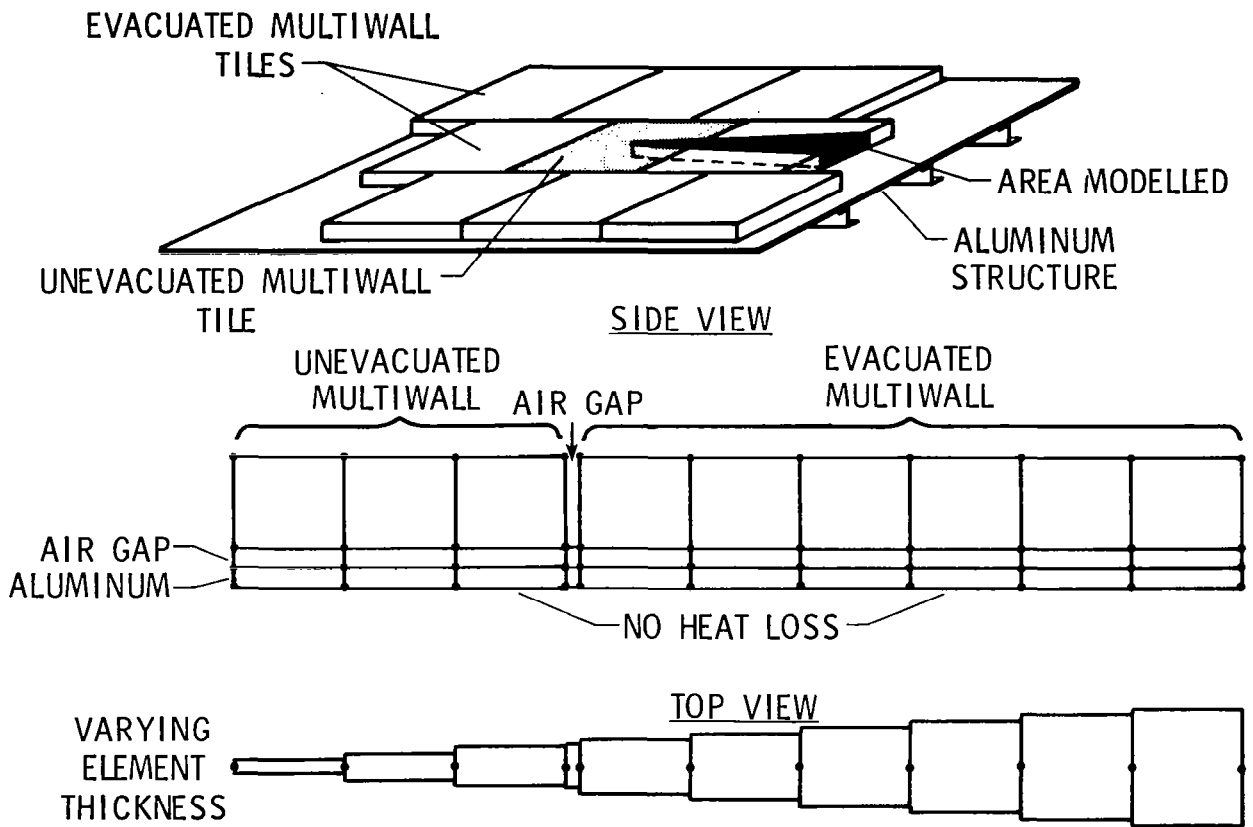

Figure 8

ANALYSIS OF EVACUATED MULTIWALL RESULTS

(Figure 9)

The maximum aluminum structural temperature, which was calculated to occur near landing, is shown on the left of the figure. The results from the first two cases are shown by the dashed lines. The upper dashed line represents the maximum structural temperature beneath an array containing all unevacuated tiles, and the lower dashed line represents the maximum structural temperature under an array containing all evacuated tiles. The 64 K (115°F) temperature difference is a measure of the improved thermal performance that results from using evacuated tiles. The solid line (case 3) represents the distribution of maximum temperatures in the structure underlying a single unevacuated tile in an evacuated array. The maximum temperature increase under the tile is only 20 K (35°F). As shown in the figure, the result of vacuum loss is not severe since the additional energy is diffused into the surrounding aluminum structure.

The surface temperatures of the evacuated and unevacuated tiles resulting from case 4 are compared on the right of the figure. Within five minutes after landing the surface temperature of an unevacuated tile, which was initially the same as that of an evacuated tile, exceeded that of the evacuated tile by approximately 11 K (20°F). Even after five hours, a 4 K (7°F) temperature difference remains as the structure slowly cools. These temperature differences could be easily detected by commercially available thermal scanning equipment. However, the structure may cool more rapidly since the analysis neglects heat loss from the backside of the structure, and consequently the surface temperature difference would diminish more rapidly. Further work would be necessary to quantitatively assess the effect of backside heat loss.

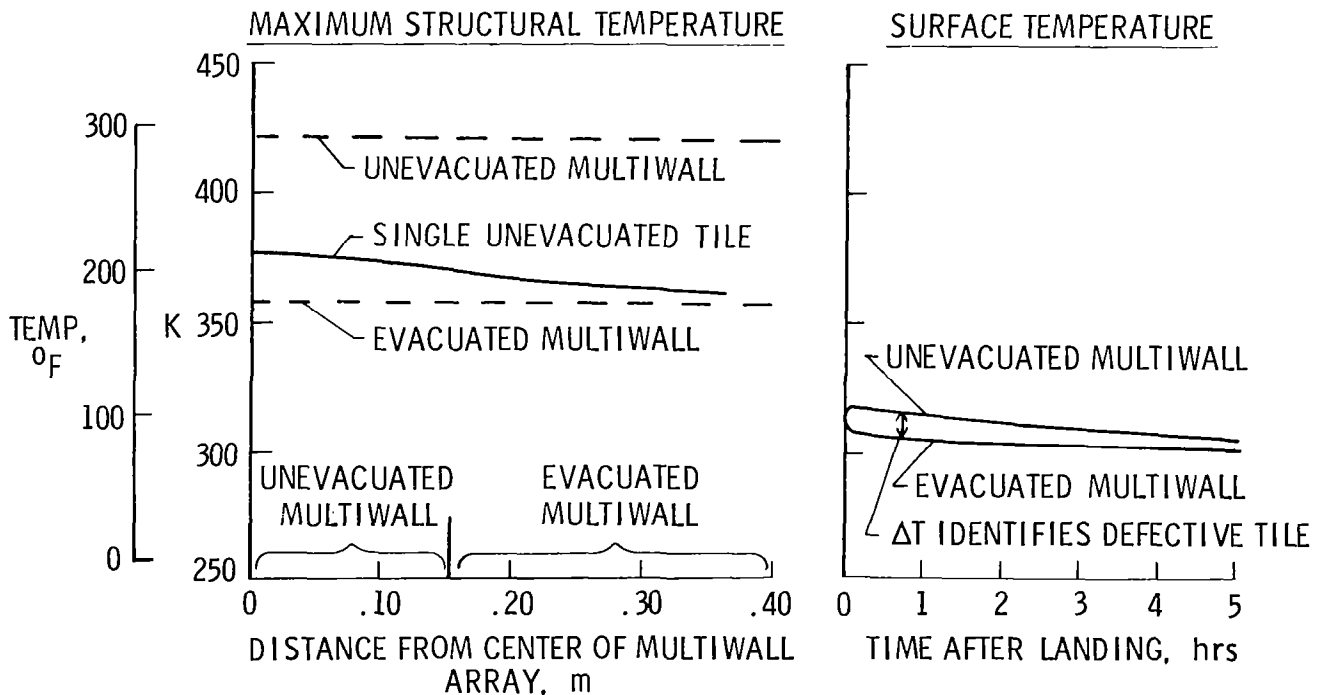

FUTURE THERMAL ANALYSIS OF TITANIUM MULTIWALL

(Figure 10)

At some point in the development of a concept the simple preliminary analyses must be followed up by more detailed and complete analyses. The simple one-dimensional model which has been used to analyze the thermal performance of the titanium multiwall concept until now is only an approximation of the heat transfer at the center of a tile. The edge effects have been neglected. A more comprehensive analysis is planned which will incorporate the details of the titanium multiwall system shown in the figure. The heat transfer through the corrugated sidewall, the mechanical attachments, the gaps between and beneath the tiles, and the nomex felt, as well as the three-dimensional effects of thermal bowing will have to be considered in a more comprehensive analysis. The SPAR Thermal Analyzer will still be used for the analysis, but with a much more complex and detailed model.

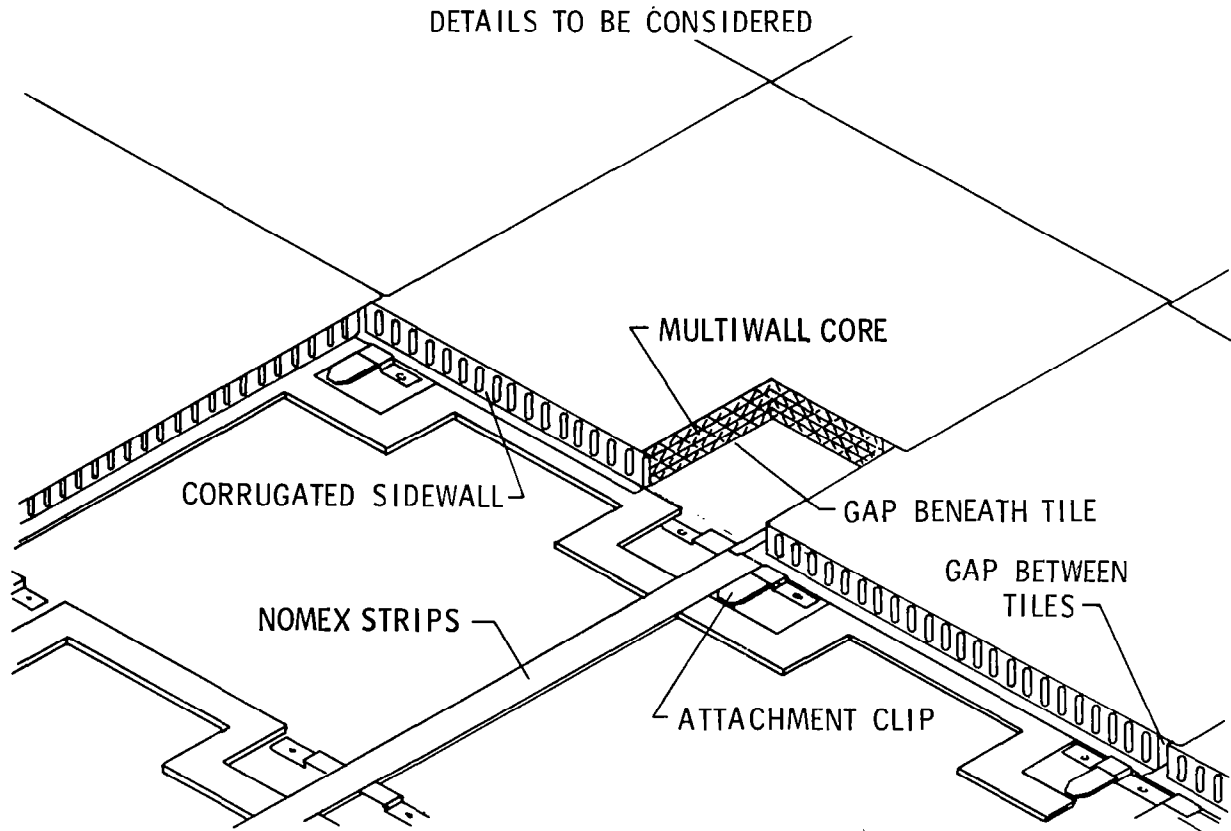



SUMMARY

(Figure 11)

The SPAR Thermal Analyzer has been used for preliminary analysis of the titanium multiwall thermal protection system concept. First a steady state analysis was performed using a detailed finite element model of a small, representative region of a multiwall tile to obtain the effective conductivity of the tile. This effective conductivity was used with simple finite element models to determine the transient thermal performance for several preliminary design studies. A more comprehensive SPAR analysis which will incorporate details of the multiwall tiles and attachments will be necessary to more accurately predict the thermal performance of the titanium multiwall thermal protection concept for final design.

- DETAILED SPAR FINITE MODEL USED TO DETERMINE EFFECTIVE MULTIWALL CONDUCTIVITY
- SIMPLIFIED SPAR MODELS USED IN TRANSIENT THERMAL ANALYSES
- COMPREHENSIVE SPAR ANALYSIS REQUIRED TO ACCURATELY PREDICT THERMAL PERFORMANCE OF MULTIWALL THERMAL PROTECTION SYSTEM

REFERENCES

1. SPAR Thermal Analysis Processors Reference Manual, System Level 16. NASA CR-159162, 1978.
2. Jackson, L. Robert: Multiwall TPS. Recent Advances in Structures for Hypersonic Flight. NASA CP-2065, Part II, 1978, pp. 671-706.
3. Jenson, Carl L.; and Gable, Richard G.: Thermal Radiation Analysis System (TRASYS II) User's Manual. NASA CR-159273-1, 1980.
4. Blair, W.; Meaney, J. E.; and Rosenthal, H. A.: Fabrication of Titanium Multi-Wall Thermal Protection System (TPS) Test Panel Arrays. NASA CR-159383, 1980.
5. Avery, Don E.; Shideler, John L.; and Stuckey, Robert N.: Thermal and Aerothermal Performance of a Titanium Multiwall Thermal Protection System. NASA TP-1961, 1981.