

HISTORICAL PERSPECTIVES ON THERMOSTRUCTURAL RESEARCH  
AT THE NACA LANGLEY AERONAUTICAL LABORATORY FROM 1948 TO 1958

Richard R. Heldenfels  
Distinguished Research Associate  
NASA Langley Research Center  
Hampton, Virginia

INTRODUCTION

This paper will describe some of the early research on structural problems produced by aerodynamic heating, conducted at the Langley Aeronautical Laboratory of the National Advisory Committee for Aeronautics from 1948 to 1958. That was the last decade of the NACA; in 1958 NACA became the nucleus of NASA.

I was one of the original investigators of these problems, became one of the leaders, and then managed such programs for the rest of my career at Langley. In this paper I will describe some activities in which I was personally involved using charts taken from papers published in those years. I have made a few literature searches to refresh my memory and locate suitable illustrations. I have not, however, approached this paper with the thoroughness of a historian; it is simply a personal recollection of some early research activities related to heat transfer in structures.

Figure 1 illustrates the organization of the NACA (ref. 1). The NACA was a committee established in 1915 to supervise and direct the scientific study of the problems of flight. The members were leaders of aeronautics in the United States and they represented government, industry, and universities. It was advised by committees and subcommittees composed of specialists in aeronautical technical areas. Only subcommittees under the Committee on Aircraft Construction are shown on figure 1 for simplicity. These committees determined policy and priorities for research. Often they focused on the urgent problems of the day, but some members were futurists who insured adequate research at the frontiers of flight. This particular type of committee organization was a significant factor in the attainment of world aeronautical superiority by the United States.

The NACA initially contracted for research but was aware that a well-equipped and suitably staffed laboratory was required to fulfill its obligations. Langley was established in 1920; the others listed were added during the NACA expansion in the World War II years.

Aircraft structures research in the NACA was concentrated at Langley, while Lewis conducted materials and structures research for propulsion systems.

## PROGRESS OF THERMOSTRUCTURAL RESEARCH

Figure 2 shows the growth of research on structural effects of aerodynamic heating. The measure used is the number of papers presented at NACA conferences that had a session on structures (refs. 2-7). These conferences were held periodically to report significant research results to the aeronautical community in advance of the published reports. The proceedings were usually classified CONFIDENTIAL, a practice rarely used by NASA today.

Elevated temperature structures research, which had just begun in 1948, had become significant by 1951, and grew steadily thereafter with a significant increase between 1955 and 1957. These steps in growth correlate with recommendations of the Subcommittee on Aircraft Structures. In 1951, that subcommittee emphasized the need for more NACA research on current and future problems associated with elevated temperature of aircraft structures. In 1955 it became concerned that the number of people in this field had remained fairly constant and recommended that the effort be increased. This recommendation was approved by the NACA and the results were evident at the 1957 conference.

Most of the Langley structures research was done in the Structures Research Division. In 1948, 1.5 man-years of effort from 47 available professionals (3%) were devoted to high-temperature structures research. The numbers were 11 of 47 (23%) in 1952 and 50 of 62 (81%) in 1957. This was not a very large research effort by today's standards. These manpower percentages on heating problems are about the same as the conference paper percentages.

In the rest of this paper, some specific research activities will be described, starting with calculation of the temperature of the structure.

### STRUCTURAL TEMPERATURE DISTRIBUTIONS

The basic principles of aerodynamic heating were known to early aeronautical scientists, but engineering data on heat transfer coefficients in supersonic flow was very limited. Figure 3 shows some results from the first NACA publication to calculate surface equilibrium temperatures in steady flight, reference 8. Results are given for Mach numbers from 2 to 10 for altitudes from 50 000 to 100 000 feet. Note that stagnation temperature was used as the maximum surface temperature instead of the adiabatic wall temperature. However, the recovery factor was discussed in the paper along with all other pertinent considerations. This 1946 paper concluded with a long list of areas needing further study.

The first transient skin temperature calculations are compared with those measured on a V-2 missile in figure 4 from a 1948 NACA publication, reference 9. This missile reached a maximum Mach number of about 5 just after 60 seconds and then coasted to 300 000 feet altitude at 100 seconds. The note concerning the basis of the calculations refers to the temperature used in the heat transfer coefficient equation.

Two NACA papers, references 9 and 10, were published at about the same time comparing calculations with the V-2 data. These papers differed in

methods for calculating the heat transfer coefficients and the numerical time integration procedures used. In those days before the electronic digital computer, such calculations could be rather tedious. Our computing machine was an electric-powered mechanical calculator.

Figure 5 shows measurements made on an NACA rocket-powered model reported at the 1951 conference, reference 3. This data was used to determine recovery factors and heat transfer coefficients which were found to be in good agreement with the available theories. Confidence was thus established in our ability to calculate thin-skin temperatures at supersonic speeds.

We turned then to the more complex problem of calculating internal structural temperature and explored the numerical solution of problems involving heat conduction within the structure. Figure 6, from the 1953 conference, reference 4, shows the methods that were evaluated by comparison with wing structural temperatures we had measured in a hot supersonic jet.

Figure 7 shows a comparison of results from two calculation methods and the data for a skin and web combination. The agreement is reasonably good. Adiabatic wall temperature and heat transfer coefficients were determined from the thin-skin temperature histories to define the conditions in the test facility.

Figure 8 shows a similar comparison along the centerline of a cross section of the wing with all important internal conduction included in the calculations. Two-dimensional conduction was required to analyze the solid leading and trailing edges.

We were pleased with these results, so our research did not emphasize techniques for calculating temperature distributions until more complex methods were needed for ablation materials in the 60's. By that time much better computational facilities were available. We did, however, explore various other phenomena such as effects of internal radiation and conductivity of joints, both analytically and experimentally. In an attempt to simplify the computations, we used an analog computer to solve the Method III problem of figure 6, but the setup time required made that an unproductive endeavor.

Heat transfer research with rocket-powered models had produced data up to  $M = 14$  by the time of the 1957 conference, reference 7, and much wind tunnel data was available to  $M = 6.8$ . The research airplanes had attained a maximum speed of  $M = 3.2$ . This speed was reached by the X-2 airplane in 1956. It went out of control later in that flight and crashed, ending the X-2 project. The research airplane program continued to collect structural heating data, however, with the X-1B and X-1E.

Skin temperature measurements were made on all high-speed research airplanes, but the X-1B, figure 9, was especially instrumented for extensive skin and internal structural temperature measurements. The airplane was brought to Langley in 1955 for instrumentation because of our experience with structural temperature measurements and was later flown at the High Speed Flight Station. This 1957 conference figure from reference 7 shows skin temperature measurement locations; many others were located in the interior to obtain about 300 total measurements.

This completes the discussion of structural temperature distributions. Their effect on the structure will be discussed next.

## STRUCTURAL EFFECTS OF AERODYNAMIC HEATING

Figure 10 was used to introduce the session on structural effects of aerodynamic heating at the 1955 conference, reference 6. It was one of many such charts used in those days to educate structural engineers not yet involved in the design of supersonic airplanes. Papers on these effects were in demand for technical conferences as were papers, similar to one I presented at the 1955 conference, on some design implications of aerodynamic heating.

Temperatures in the airframe have been discussed in the previous section. The charts that follow will address some of the items under structures and touch briefly on alleviation. I will not address the items under materials for lack of time. The change in material properties with temperature is the most important effect of aerodynamic heating on structural design and was the subject of the earliest structures research. This effect, however, was relatively simple to incorporate into structural design because prediction of structural buckling and strength was based on the stress-strain characteristics of the material.

I came to work at Langley in 1947 after engineering jobs with an aircraft company and the U. S. Army Air Corps at Wright Field. My first assignment was to a team developing methods for structural analysis of a sweptback wing. Although airplanes were being built with sweptback wings, the structural design methods of the time could not predict accurately the stresses and deflections of this new wing configuration. Figure 11, from the 1948 conference, reference 2, shows the idealized structure we used to represent a wing structure we had tested. I show this chart to emphasize the limitations on our ability to calculate stresses in a complex redundant structure. With this idealization we were able to reduce the principal computation to reduction of a 9 x 9 matrix (ref. 11). Today computer programs are available to solve this problem in great detail very quickly.

Our analysis method for the sweptback wing was presented at the 1948 conference. That conference included, also, the first NACA paper on a structural problem produced by aerodynamic heating. It was a thermal stress analysis of a multiweb wing under an arbitrary temperature distribution. This preliminary analysis was not completed because the principal investigator left Langley. In August 1948, I was assigned to continue the development of methods for thermal stress analysis. I became one of a very few people at Langley who were working then on elevated temperature structural problems. Initially, I put thermal expansion terms into the current analytical and numerical methods and applied them to some illustrative examples (refs. 12 and 13). What we called numerical methods then were later called finite-element methods. However, in 1948 axially loaded rods and rectangular panels that carried only shear constituted our complete stable of finite elements. We did, however, create a special triangular element for our swept wing analysis (fig. 11).

We devised the simple experiment shown in figure 12 to obtain experimental verification of our thermal stress methods. Steady-state thermal stresses were induced in a large, thick plate by heating the center and

cooling the edges. This is typical of the kind of experimental structures research we conducted. Tests were designed to be critical in nature and limited in scope to get to the crux of the problem quickly and economically.

Figure 13, presented at the 1951 conference, reference 3, shows the excellent agreement we obtained between the theory and experiment for the longitudinal direct stresses. Similar results were obtained for the shear stresses and the transverse direct stresses that occur because of the free ends (ref. 14).

The theoretical results were obtained from an approximate solution based on the principle of minimum complementary energy. To do that I had to derive the correct energy term; I did it by working backwards from the differential equations. In those days some theoreticians did not agree on a rational derivation of this term, but I was satisfied with one that worked.

The plate of figure 12 was set up on simple edge supports to conduct a thermal buckling experiment. Figure 14 shows a comparison of the results of those tests with calculated results, also from the 1951 conference. These calculations used the previously described thermal stress methods and the energy method to solve the large-deflection buckling problem (ref. 15). The plate contained initial curvature; therefore, it began to buckle as soon as thermal stresses were induced.

With adequate methods for analysis of thermal stress and thermal buckling, we left their refinement to others and began to investigate effects of rapid heating on strength and stiffness. A wide variety of tests and analyses were made of simple structures subjected to rapid and steady heating. Figure 15, from the 1957 conference, reference 7, presents some important results on the effect of thermal stress on the failure strength of beams. These square tubes were tested with and without thermal stress and the failure load was essentially the same. The lines on the figure are calculated failure loads based on material properties at temperature. Thermal stress, however, did reduce the buckling load for these beams. These results removed some concerns about the importance of thermal stresses because they did not affect certain modes of structural failure.

Figure 16, from the 1955 conference, reference 6, shows a cantilever plate, heated along the edges to investigate changes in structural stiffness produced by nonuniform temperature distributions and thermal stresses. The radiant heaters were turned off at 16.2 seconds and the plate began to cool at the edges. During the heating the plate was periodically struck to excite its fundamental bending and torsion modes.

Figure 17 (ref. 16) shows the change in the frequency of the first torsion mode (35%), the one most affected by this type of temperature distribution. The first bending frequency was reduced 21%. The plate twisted also, because the thermal stresses coupled with the initial twist in the plate.

The techniques for calculating thermal stress and buckling described with figures 13 and 14 were used with the addition of a frequency term to obtain the theoretical results which are seen to be in good agreement with the data. Measured temperature distributions were used in these calculations.

In the course of our stiffness reduction research we developed a system for following a resonant frequency as it changed during a heating test. We used it to test some wing structures; typical results are shown in figure 18 from the 1957 conference, reference 7. This solid, double wedge wing experienced small changes in the first five natural modes. The radiant heating used however, was not a good simulation of aerodynamic heating of this type of wing. Similar tests on multiweb wings showed frequency changes twice as large for the mode shapes characteristic of that type of structure.

We devoted much effort to the study of stiffness changes due to thermal stress, but I am not aware of this problem ever being important in the design of an airplane, missile, or space vehicle except with respect to panel flutter. Panel flutter is beyond the scope of this lecture because the primary investigations of the effects of aerodynamic heating on it were conducted in later NASA programs.

Our interest in changes of effective stiffness was not generated by any theoretical insight but by a 1952 experiment that produced startling and totally unexpected results. Figure 19, from the 1953 conference, reference 4, shows the test facility and one of the test specimens in the program. The test facility was a free jet, 27 x 27 inch size, with an exit Mach number of 2 and a stagnation temperature of 500°F. The model shown had a 20-inch chord and span, typical of most models tested. The first test was made on a model twice that size to obtain the temperature data shown in figures 7 and 8. Near the end of that test the model appeared to experience panel buckling and vibration that led to its destruction. Many additional tests were made on models like that shown here to identify the failure mode and methods for its prevention.

Figure 20 (ref. 4) shows the camber type flutter that resulted from stiffness changes produced by aerodynamic heating. The wings that fluttered had very low resistance to shear deformation of the cross section, and the fifth natural vibration mode, the one most affected by thermal stress, involving such deformations was predominant in the response.

The spectacular nature of these failures provided our program with high priority support but, again, I am not aware of such a failure mode being important in the design of any aerospace vehicle. In any event, this type flutter is easily prevented by the addition of a few ribs. A theoretical analysis of this type of flutter, that correlated well with our test results, was published in 1962 (ref. 17).

In addition to coping with aerodynamic heating, means to alleviate it were also of interest. Our initial analysis indicated that alleviation by insulation was of greatest interest at hypersonic speeds so we did not do much thermal protection research until the late 50's. Figure 21, from the 1957 conference, reference 7, shows some insulating panels that had been evaluated by a variety of tests. These panels were designed and constructed by the Bell Aircraft Company for lifting-entry vehicle applications; they called them double-wall construction. Research is still continuing on similar concepts but applications have been relatively few. Two that come to mind are the afterbodies of the Mercury and Gemini capsules.

Many other theoretical and experimental programs were undertaken in the years under discussion, but time does not permit comprehensive coverage. Equally important as the research planning and execution was the conception, construction, and operation of test facilities.

## HIGH-TEMPERATURE STRUCTURAL TEST FACILITIES

Development of test equipment and facilities began along with the initiation of research projects and accelerated along with their expansion. Prior to the expansion in 1955, a presentation was made to several advisory groups on the NACA approach to high-temperature research facilities (ref. 18). Additional detail is given in reference 19 of some subsequent developments.

Figure 22, from reference 18, lists the types of facilities under development along with the general types of structures research testing that was needed. Combinations of furnaces and testing machines were the principal generators of data on materials and structural elements. Figure 23 shows a large furnace for strength and creep tests of structures. We did much short-time creep testing because it was thought to be an important design consideration for high-speed aircraft. However, when we related our results to design criteria, we concluded that airplanes would not be designed to operate in the creep range of the material (ref. 20). Therefore, we de-emphasized creep in our program starting in 1956. Subsequent events supported this decision.

Starting in 1951, we began to search for ways to simulate or duplicate aerodynamic heating in the laboratory. We evaluated a variety of devices for radiative and convective heating of structures. One of our goals was to achieve initial heating rates of 100 Btu per square foot per second. This was derived from calculations of the heat transfer rate to airplanes accelerating to  $M = 3$  or  $M = 4$  at 50 000 feet. That turned out to be a very valid long-range goal for airplanes because very few fly that fast even today.

The first device used extensively for rapid heating was the carbon-rod radiator shown in figure 24. It provided the desired heating rate but the high thermal inertia of the rods required that mechanical shields be used to control the heat radiated to the test specimen.

The tungsten filament lamp was a much better radiant heating device because it could be controlled adequately by the power input. But the available lamps were not sufficiently powerful to meet our goal. Fortunately, General Electric was developing a quartz-tube lamp with the desired characteristics. We acquired some development lamps, 5 inches long, in 1952 that were very promising. We requested that they make lamps with a 10 inch effective length. These lamps, shown in two double-row high-intensity heaters in figure 25, met our requirements and were the heat source used in most of our future heating tests. Coupled to an appropriate power supply and control system, this type of lamp, in lengths from 10 to 50 inches, became the principal method for rapidly heating structures in laboratories throughout the world. Numerous commercial applications were made also.

Convective heating to simulate or duplicate aerodynamic heating was investigated from the beginning of our facility development program and a variety of techniques were tried. The results were several supersonic jets and wind tunnels that provided a duplication of high-speed flight or a simulation with the stagnation temperature higher than that achieved in flight at the same Mach number. This was a consequence of the practical problems of duplicating hypersonic flight conditions in a wind tunnel.

Development of hot wind tunnels is a long and interesting story in itself, so I can only discuss a few highlights in this paper. Figure 26, which I used in a talk in April 1959, shows the operational (black) and planned facilities in the first year of NASA.

In March 1951 we had begun to plan an increase in our elevated temperature structures research. Langley management decided in June 1951 that we should plan also for large high-temperature structural research laboratory. Hot subsonic air flow and radiant heating panels were proposed to heat structures in a large test chamber. Further study and testing, however, revealed that a true-temperature,  $M = 3$ , blowdown wind tunnel was the best approach. This became the 9 x 6 Foot Thermal Structures Tunnel. Its basic characteristics were established in March 1952, the tunnel became operational in 1957, and research testing began in the summer of 1958. Construction was delayed when the funds initially appropriated were withdrawn by Congress in a federal budget reduction action. This facility was used to test a wide variety of structural models, many of which were evaluated for panel flutter. A structural failure in the air storage field, in September 1977, made further operations impractical.

The ethylene jet and the ceramic heaters were very high-temperature supersonic jets for testing materials and small models. The electric-arc powered jets subsequently carried this capability to extremely high temperatures. Their original development was motivated by the long-range ballistic missile program, but these Langley facilities made their major contribution later to the manned space flight programs, including the Space Shuttle.

The facility labeled 7' HTF is the initial concept of the facility now known as the 8-Foot High-Temperature Structures Tunnel. It is a true-temperature,  $M = 7$  blowdown wind tunnel. Construction began in 1960 and high-temperature testing began in 1968. Although nearly 10 years elapsed between concept and research, this facility was on line long before the vehicles that benefited from its testing became a reality.

The rocket models listed on figure 22 have been discussed earlier. They made essential contributions to heat transfer data at very high speeds and did some structural testing also. Research airplanes were mentioned earlier, but that program received a new thrust when the NACA decided, in the spring of 1952, to initiate studies of problems likely to be encountered in space flight and of methods for exploring them.



## THE X-15 RESEARCH AIRPLANE

A task group of five senior researchers was established at Langley in March 1954 to define the characteristics of an airplane to explore problems of hypersonic and space flight. The principal features of the vehicle they proposed are shown in Figure 27 from reference 21. It was a relatively small vehicle to be air-launched from a B-36 airplane, and then rocket-propelled to a maximum speed of 6 600 feet per second or to a maximum altitude of more than 250 000 feet.

The task group recommended a heat-sink type structure of Inconel X material. Their rationale is displayed in Figure 28 (ref. 21). Inconel X retains its strength well to 1200°F; this temperature established the heat-sink thickness required. However, much of the skin was strength critical so the heat sink criteria applied principally to secondary structure.

In December 1954, NACA, the Air Force, and the Navy agreed to sponsor this research airplane project with the Air Force managing the design and construction and NACA providing technical direction. The procurement process occupied most of 1955 with 4 of 10 interested companies submitting proposals. The winner is shown in figure 29 from reference 21. This airplane was very much like the results of the NACA study. If my memory serves me correctly, two of the other proposals presented a shielded structure and the third one recommended a magnesium heat sink. That rather novel approach raised some very valid concerns for the evaluation team since magnesium burns very intensely under certain conditions. We had great fun running a wide variety of tests using several different facilities to determine when a magnesium structure would ignite in flight. We found, for example, that a burning thin skin could be quenched by an adjacent, thicker spar cap.

Figure 30 (ref. 21) shows some of the early structural temperature calculations. In this case the wing-skin temperatures are much lower than the 1200°F limit because of strength requirements and mission characteristics.

Construction of the three X-15 airplanes was completed in 1959 with the first flight in June of that year. The flight program continued until December 1968 and provided much information on heat transfer and structural temperatures in high-speed high-altitude flight.

Support of the X-15 program was a high priority activity at Langley and we made many tests and analyses of potential problems. We made vibration tests of the horizontal tail under radiant heating and found that the resultant stiffness changes were not significant. Panel flutter, however, was a problem in several areas. Tests made in various wind tunnels included the horizontal and vertical tails in the 9 x 6 Foot Thermal Structures Tunnel. As a result, stiffeners were added to many thin-skin panels to prevent panel flutter within the flight envelope of the X-15.

## NACA BECOMES NASA

The Soviet Union launched the first Earth satellite on October 4, 1957. This brought immediate changes in NACA programs as many people began to plan space research and flight programs. By December of 1957 I had prepared a plan

for structures and materials research needed to rapidly advance manned space flight and we initiated some of these projects as people could be made available. The National Aeronautics and Space Act of 1958 (approved July 29, 1958) created NASA and at the close of business on September 30, 1958 the NACA ceased to exist. All of its property, facilities, and personnel were absorbed by NASA.

The NACA had excellent facilities and personnel that could get the space program off to a fast start. Much was accomplished in the year between Sputnik I and the official establishment of NASA. In fact, a bidder's briefing for a manned satellite capsule (Project Mercury) was held at Langley on November 7, 1958, just one year and five weeks after Sputnik I.

Although a new era in structures research had begun, we continued to support aircraft and missile needs along with the new emphasis on space. Our prior research experience, however, led us to concentrate much of our program on the technology required to return space vehicles to a safe landing on Earth.

Figure 31, from reference 19, which was prepared during the last days of the NACA, shows the flight regions in which our high-temperature structures research was focused. Charts like this were used with overlays to evaluate the capabilities of our test facilities relative to proposed flight systems. In addition to the airplanes and missiles that were the motivation of our initial research, we had supported the long-range ballistic missile program and the reentry glider of the USAF Dyna-Soar program for a manned orbital system. Dyna-Soar started in 1958 after preliminary studies called ROBO, BRASSBELL, BOMI, and HYWARDS. Less than a year later in 1959, I presented a similar chart that showed reentry vehicles at speeds twice orbital velocity and hypersonic airplanes at  $M = 6$  to 9. The NASA years brought a greater scope and a faster pace to our research, but a decade of experience had prepared us well for this new challenge.

#### CONCLUDING REMARKS

In the foregoing, I have described briefly some of the research activities at Langley in the first decade of high-temperature structures research. Many other interesting activities could not be included.

Techniques for both experimental and analytical research have improved greatly in the last three decades with advances in electronics (instruments and computers) making the major contributions. Although much new knowledge is being acquired at a rapid rate, the search must always continue. My experience shows that the old problems are never completely solved; they just keep turning up in different situations and under other circumstances.

Our research began without a clear definition of the future vehicles to which it would apply. Therefore, we were concerned initially with generic research on potential problems. As a result, some of these problems were of little practical importance to the vehicles that were developed later. On the other hand, some vehicles that were proposed were never built or came into being much later than expected. For example,

- o Few supersonic airplanes fly faster than  $M = 3$  today.
- o The hypersonic airplane has not had a mission important enough to warrant its development.
- o A reusable orbital vehicle, the Space Shuttle, finally demonstrated that capability over twenty years after the Dyna-Soar project was started.

These examples lead to my principal message. Vehicle oriented research programs, which seem to be favored in today's environment, have the advantage of speeding the development of new technology for a specific mission or vehicle. An inherent danger in this approach, however, is that too much effort will be expended on developing technology that may not be used because the vehicle is never constructed. A healthy research program must provide freedom to explore new ideas that have no obvious applications at the time. These ideas may generate the technology that makes important, unanticipated flight or vehicle opportunities possible. Fortunately for the United States, this freedom of inquiry was fostered by the National Advisory Committee for Aeronautics, making possible our world leadership first in aeronautics and then in space.

## REFERENCES

1. Forty-third Annual Report of the National Advisory Committee for Aeronautics - 1957. U.S. Government Printing Office, 1957.
2. NACA Conference on Aircraft Structures - A Compilation of the Papers Presented. NACA, May 1948.
3. NACA Conference on Aircraft Structures - A Compilation of the Papers Presented. NACA, Mar. 1951.
4. NACA Conference on Aircraft Loads, Flutter, and Structures - A Compilation of the Papers Presented. NACA, Mar. 1953. (Available as NASA TM X-57364.)
5. NACA-University Conference on Aerodynamics, Construction, and Propulsion. Volume I - Aircraft Structures and Materials. NACA, Oct. 1954. (Available as NASA TM X-57206.)
6. NACA Conference on Aircraft Loads, Flutter, and Structures - A Compilation of the Papers Presented. NACA, Mar. 1955. (Available as NASA TM X-57821.)
7. NACA Conference on Aircraft Loads, Structures, and Flutter - A Compilation of the Papers Presented. NACA, Mar. 1957. (Available as NASA TM X-67367.)
8. Wood, George P.: Calculation of Surface Temperatures in Steady Supersonic Flight. NACA TN 1114, 1946.
9. Huston, Wilber B.; Warfield, Calvin N.; and Stone Anna Z.: A Study of Skin Temperatures of Conical Bodies in Supersonic Flight. NACA TN 1724, 1948.
10. Lo, Hsu: Determination of Transient Skin Temperature of Conical Bodies During Short-Time, High-Speed Flight. NACA TN 1725, 1948.
11. Heldenfels, Richard R.; Zender, George W.; and Libove, Charles: Stress and Distortion Analysis of a Swept Box Beam Having Bulkheads Perpendicular to the Spars. NACA TN 2232, 1950.
12. Heldenfels, Richard R.: The Effect of Nonuniform Temperature Distributions on the Stresses and Distortions of Stiffened-Shell Structures. NACA TN 2240, 1950.
13. Heldenfels, Richard R.: A Numerical Method for the Stress Analysis of Stiffened-Shell Structures Under Nonuniform Temperature Distributions. NACA Rep. 1043, 1951. (Supersedes NACA TN 2241.)
14. Heldenfels, Richard R.; and Roberts, William M.: Experimental and Theoretical Determination of Thermal Stresses in a Flat Plate. NACA TN 2769, 1952.
15. Gossard, Myron L.; Seide, Paul; and Roberts, William M.: Thermal Buckling of Plates. NACA TN 2771, 1952.
16. Heldenfels, Richard R.; and Vosteen, Louis F.: Approximate Analysis of Effects of Large Deflections and Initial Twist on Torsional Stiffness of a Cantilever Plate Subjected to Thermal Stresses. NACA Rep. 1361, 1958. (Supersedes NACA TN 4067.)

17. Thomson, Robert G.; and Kruszewski, Edwin T.: Theoretical Study of Camber Flutter Characteristics of Monocoque and Multiweb Wings. NASA TR R-150, 1962.
18. Purser, Paul E.; and Heldenfels, Richard R.: Presentation on Facility Problems in High-Temperature Structures Research. NACA RM L56C24, 1956.
19. Heldenfels, Richard R.: High-Temperature Testing of Aircraft Structures. AGARD Rep. 205, 1958.
20. Heldenfels, Richard R.; and Mathauser, Eldon E.: A Summary of NACA Research on the Strength and Creep of Aircraft Structures at Elevated Temperatures. NACA RM L56D06, 1956.
21. Research-Airplane-Committee Report on Conference on the Progress of the X-15 Project - A Compilation of the Papers Presented. NACA, Oct. 1956. (Available as NASA TM X-57072.)

## SYMBOLS

$b$	width
$f_0$	frequency of unheated structure
$f/f_0$	change in frequency due to heating
$M$	Mach number
$T$	temperature
$T_{aw}$	adiabatic-wall temperature
$T_B$	boundary-layer temperature
$T_0$	initial temperature
$T_s$	surface or skin temperature
$T_T$	stagnation temperature
$t$	thickness
$W_{i_c}$	initial center deflection of plate
$W_c$	center deflection of plate
$\epsilon$	emissivity
$\tau$	time
$\omega/\omega_0$	change in circular frequency due to heating

COMMITTEES

SUBCOMMITTEES

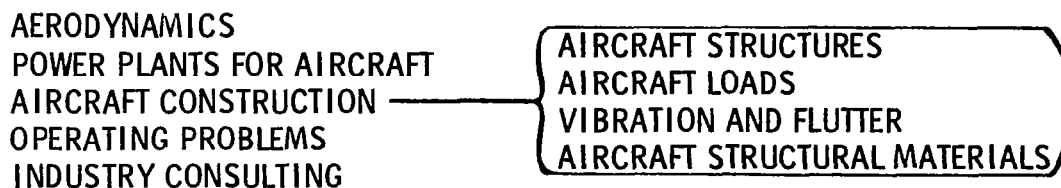

RESEARCH INSTALLATIONS

LANGLEY AERONAUTICAL LABORATORY	VIRGINIA
AMES AERONAUTICAL LABORATORY	CALIFORNIA
LEWIS FLIGHT PROPULSION LABORATORY	OHIO
HIGH SPEED FLIGHT STATION	CALIFORNIA
PILOTLESS AIRCRAFT RESEARCH STATION	VIRGINIA

Figure 1.- Organization of National Advisory Committee for Aeronautics (NACA).

<u>DATE</u>	<u>PAPERS PRESENTED</u>		<u>PERCENT HEATING</u>
	<u>TOTAL</u>	<u>HEATING</u>	
MAY 1948	17	1	6
MARCH 1951	15	4	27
MARCH 1953	16	5	31
OCTOBER 1954	5	2	40
MARCH 1955	16	8	50
MARCH 1957	19	15	79

Figure 2.- Structures papers presented at NACA conferences.

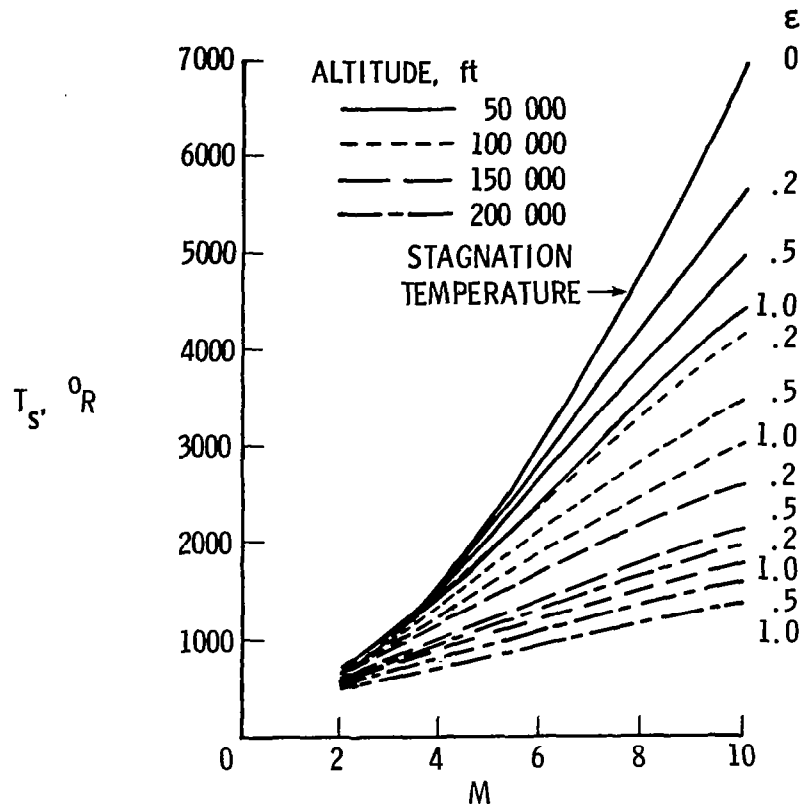

(a)  $M_i$  FROM 2 TO 10.

Figure 3.- Calculated surface equilibrium temperatures in steady flight.

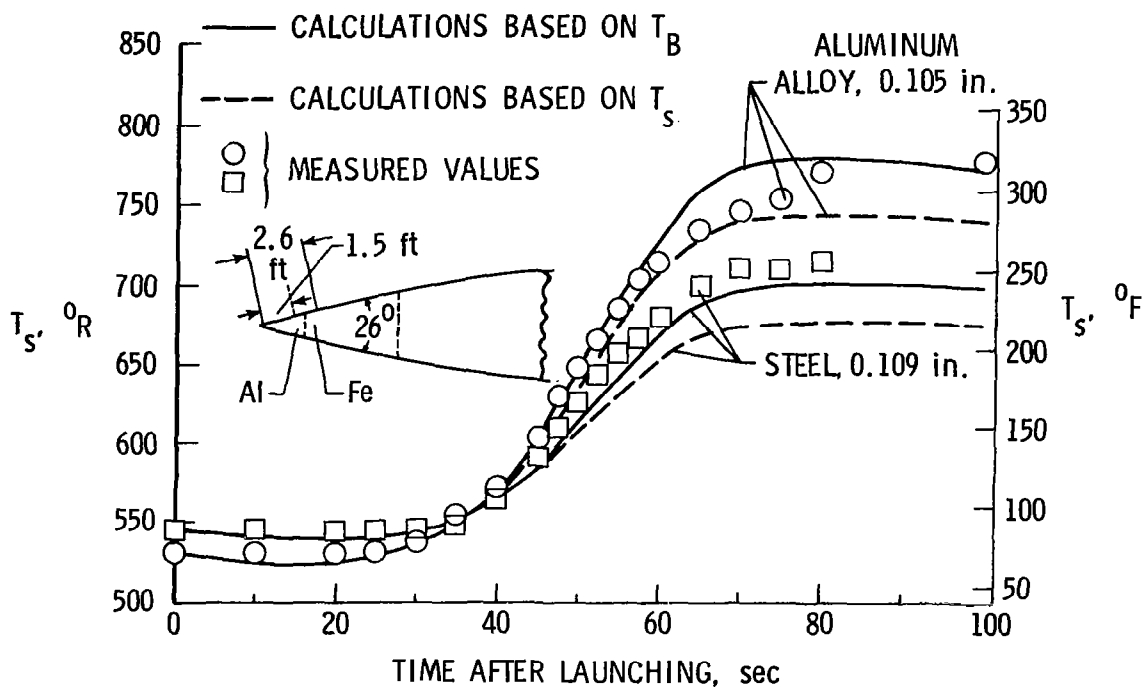

Figure 4.- Calculated transient skin temperatures compared with those measured on V-2 missile.



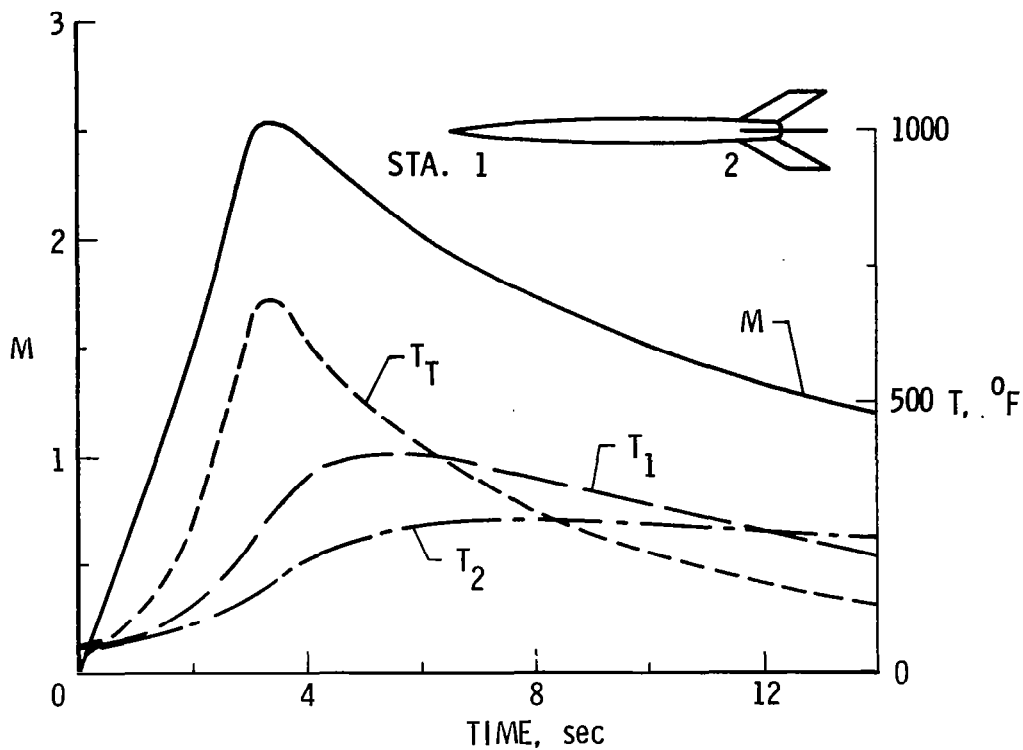

Figure 5.- Temperature history on NACA rocket-powered model.

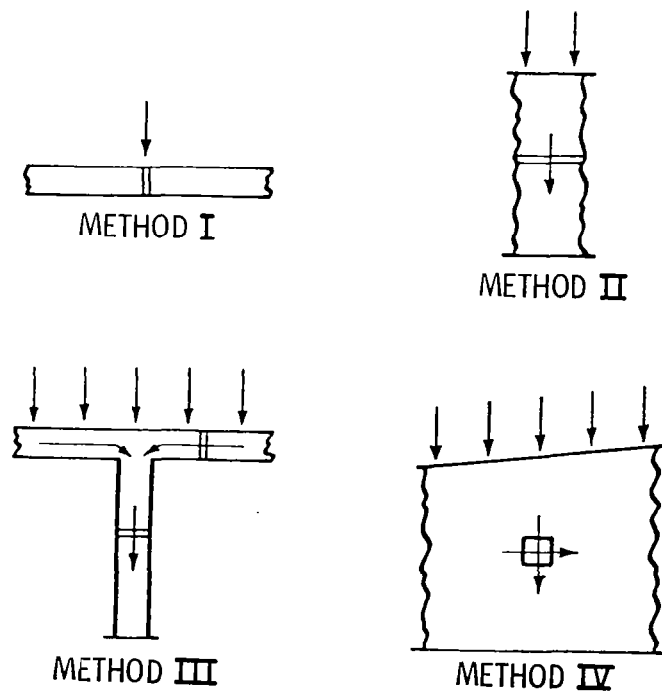

Figure 6.- Methods for calculating internal structural temperatures.

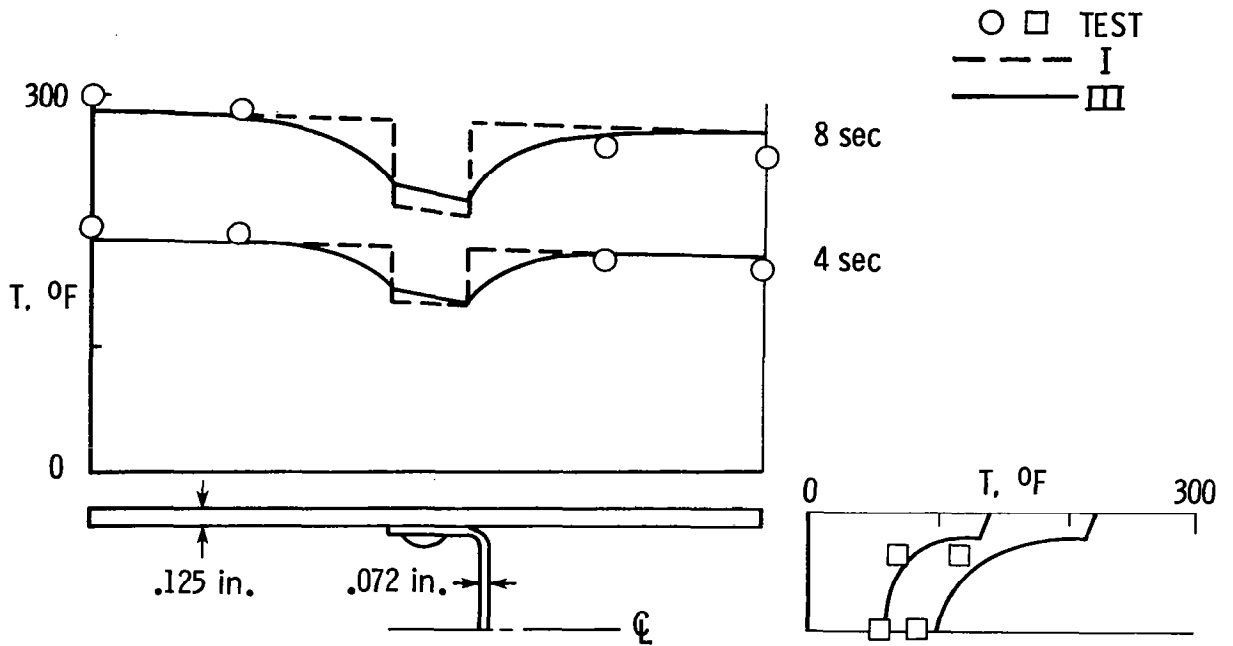

Figure 7.- Skin and web temperature distributions.

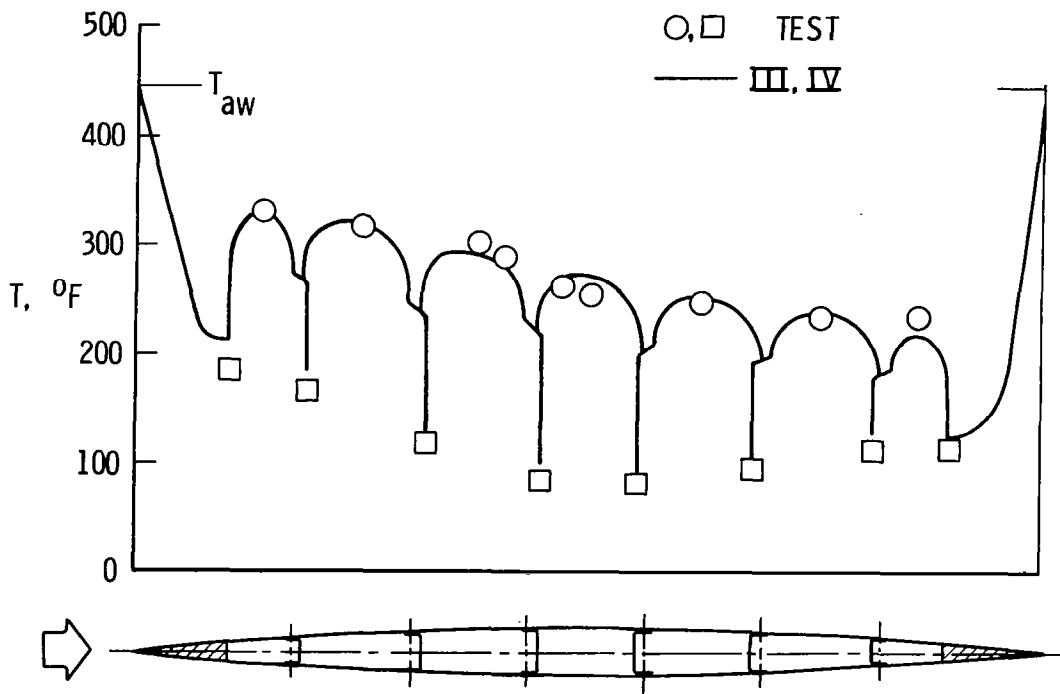

Figure 8.- Chordwise temperature distribution along centerline of wing cross section.

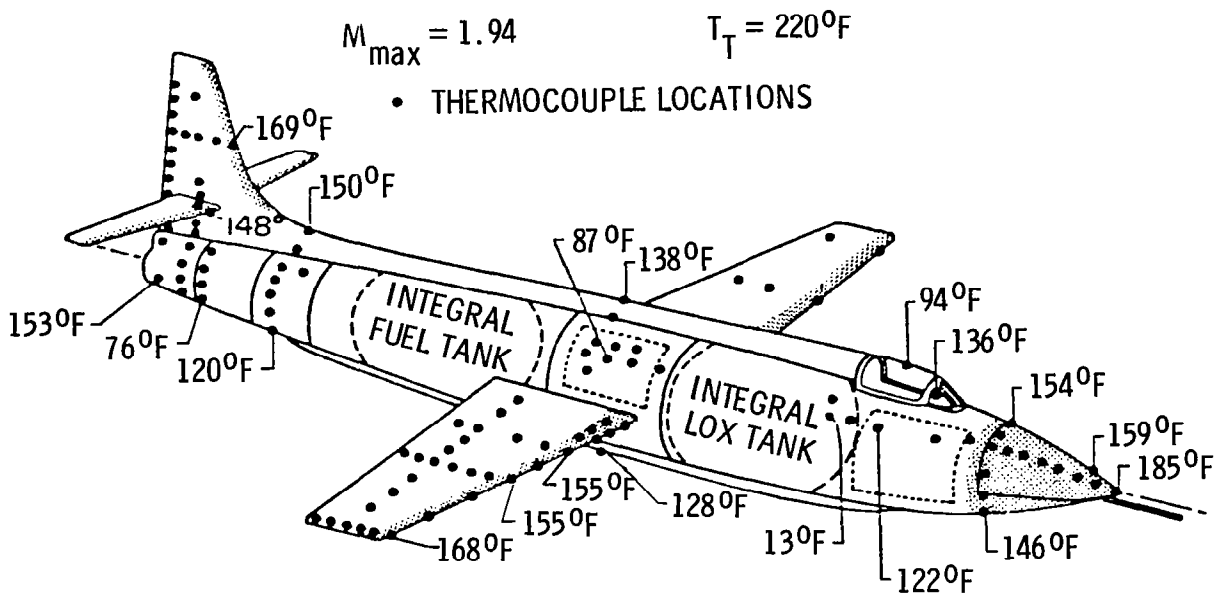

Figure 9.- Maximum measured temperatures on X-1B airplane.

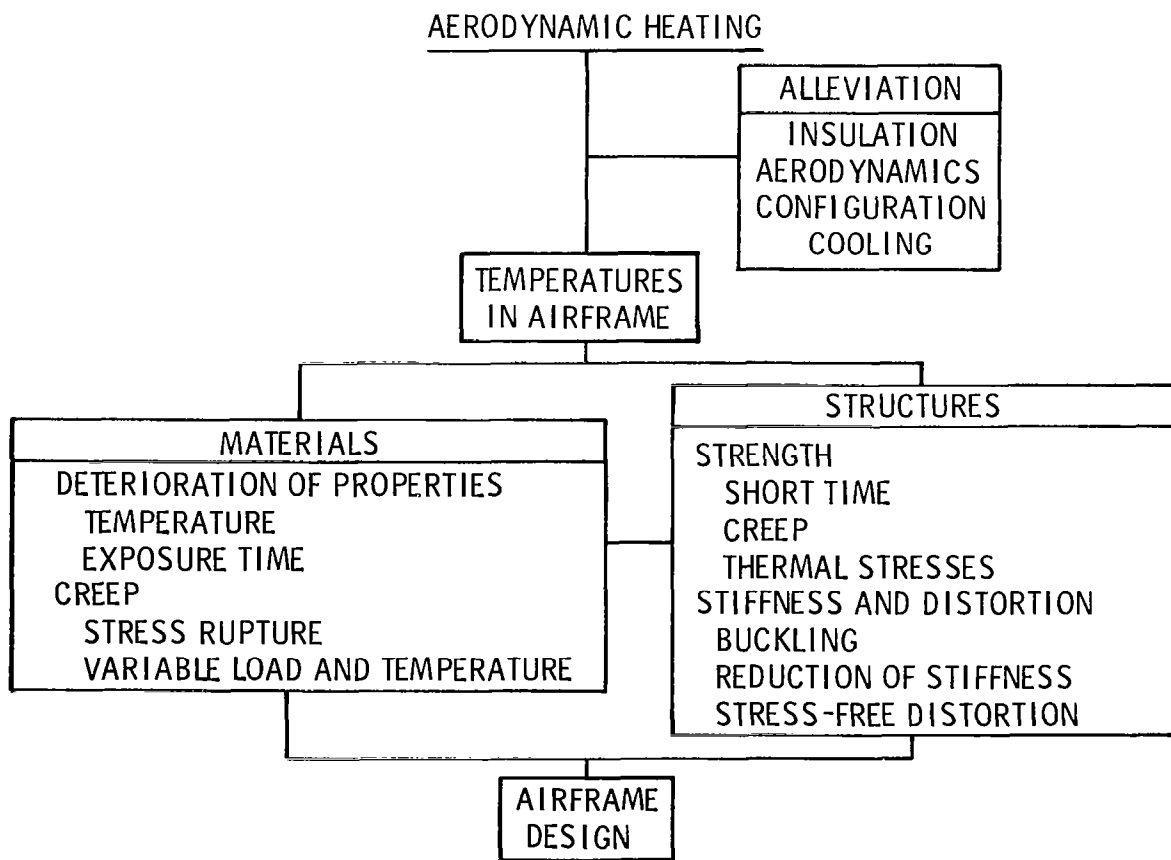

Figure 10.- Introductory chart at 1955 NACA Conference on Aircraft Loads, Flutter, and Structures.

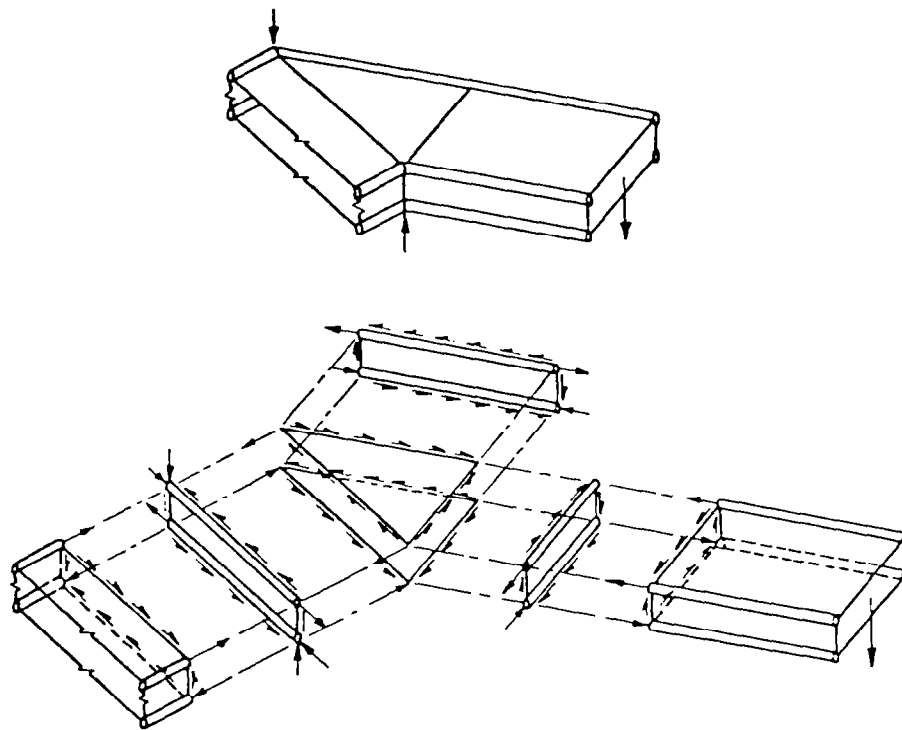

Figure 11.- Equivalent structure and breakdown used in structural analysis.

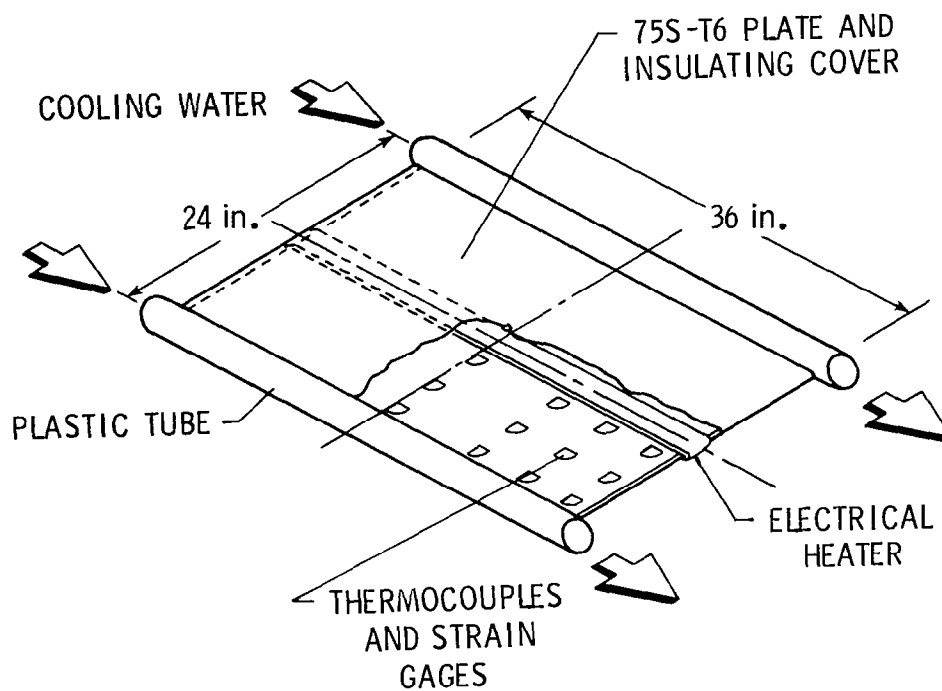

Figure 12.- Plate used for thermal stress test.

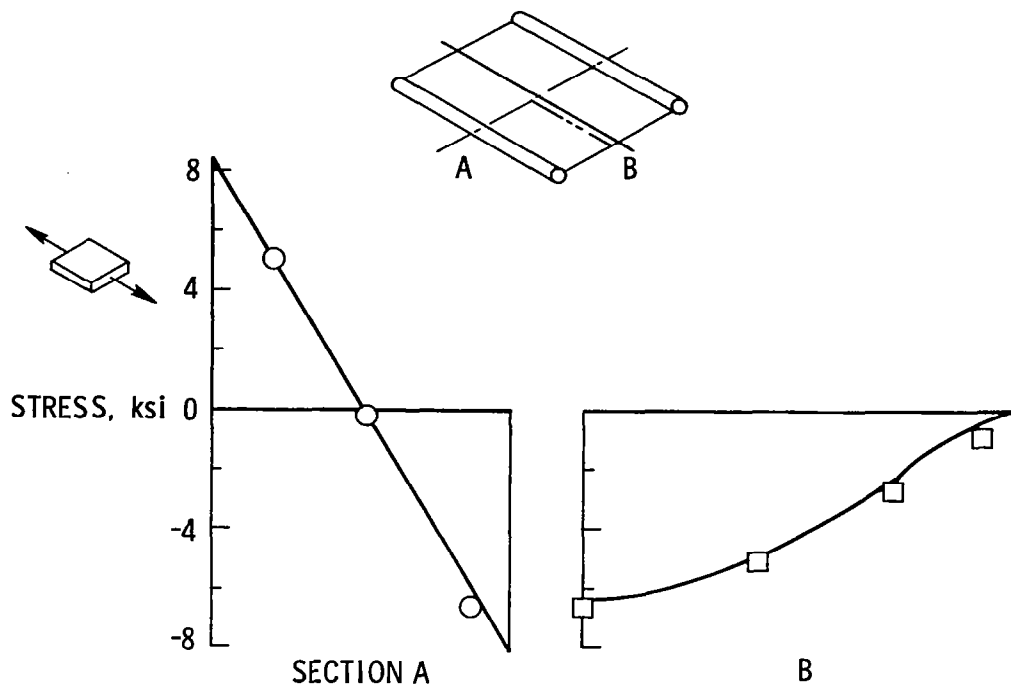

Figure 13.- Agreement between theory and experiment for longitudinal direct thermal stresses.

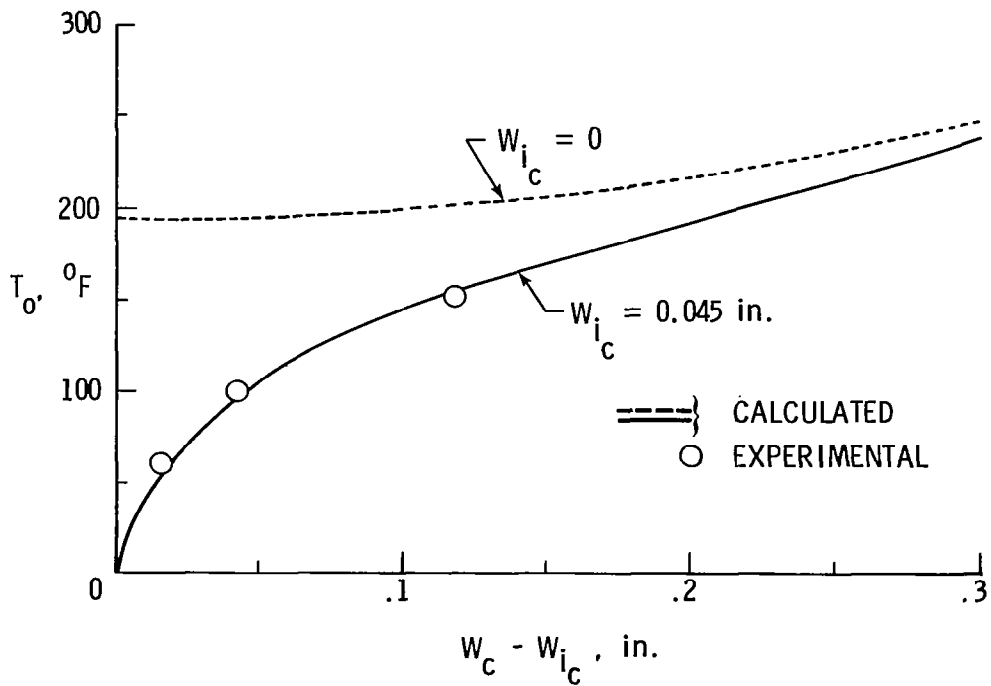

Figure 14.- Comparison between experiment and calculation for thermal buckling of a plate.

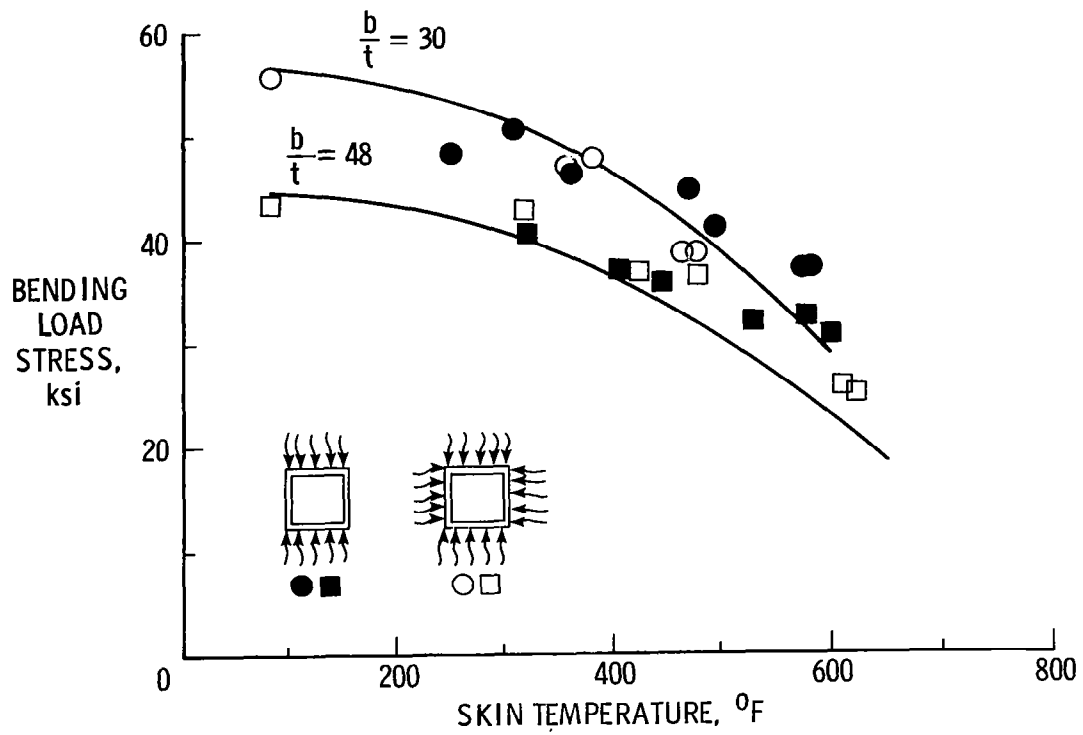

Figure 15. Rapid-heating effects on failure of 2014-T6 aluminum alloy beams.  
 $T = 100^\circ\text{F}/\text{sec}$ .

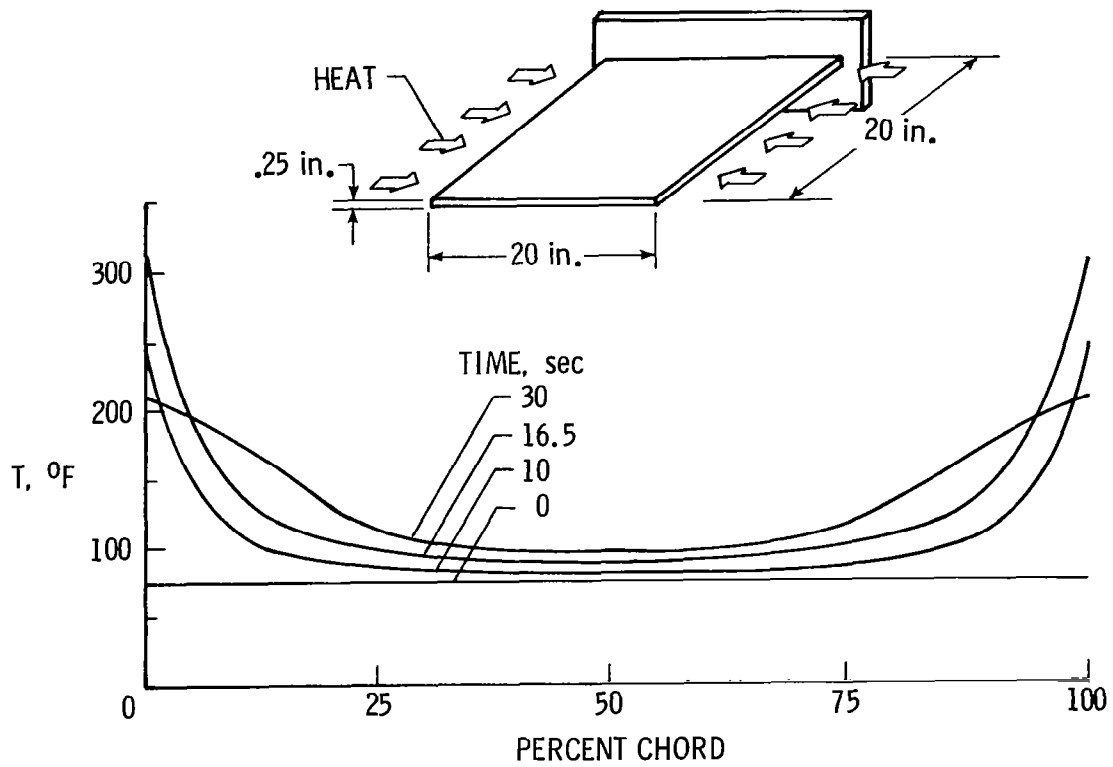

Figure 16.- Radiantly heated cantilever plate.

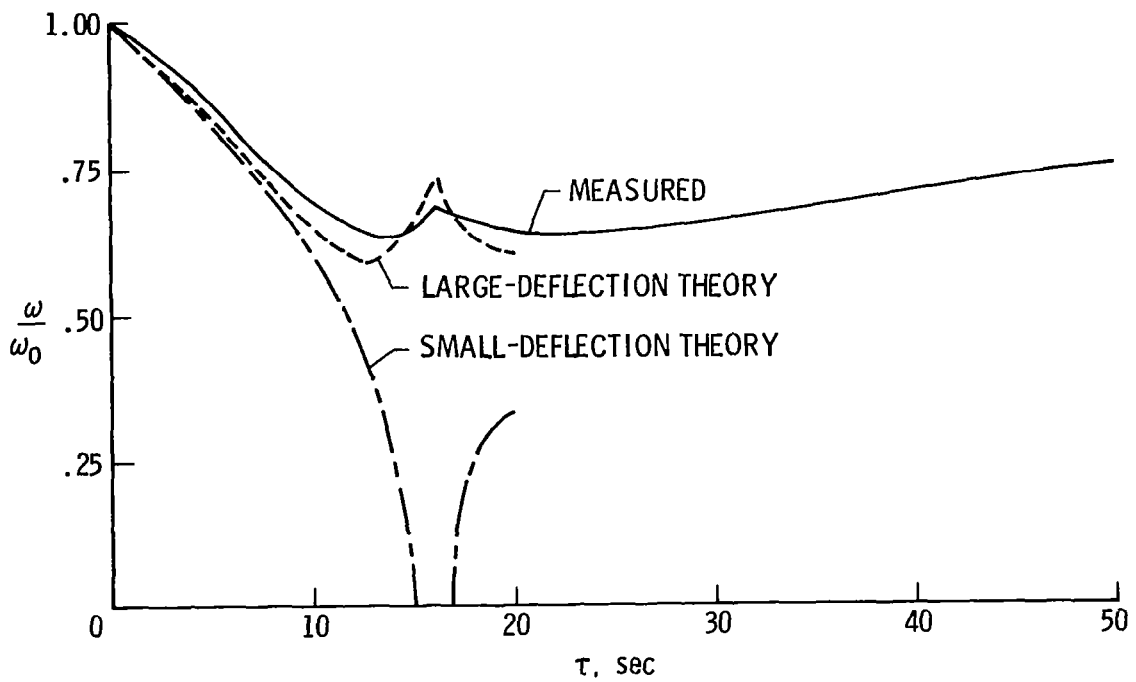

Figure 17.- Change in first torsion mode frequency of rapidly heated plate.

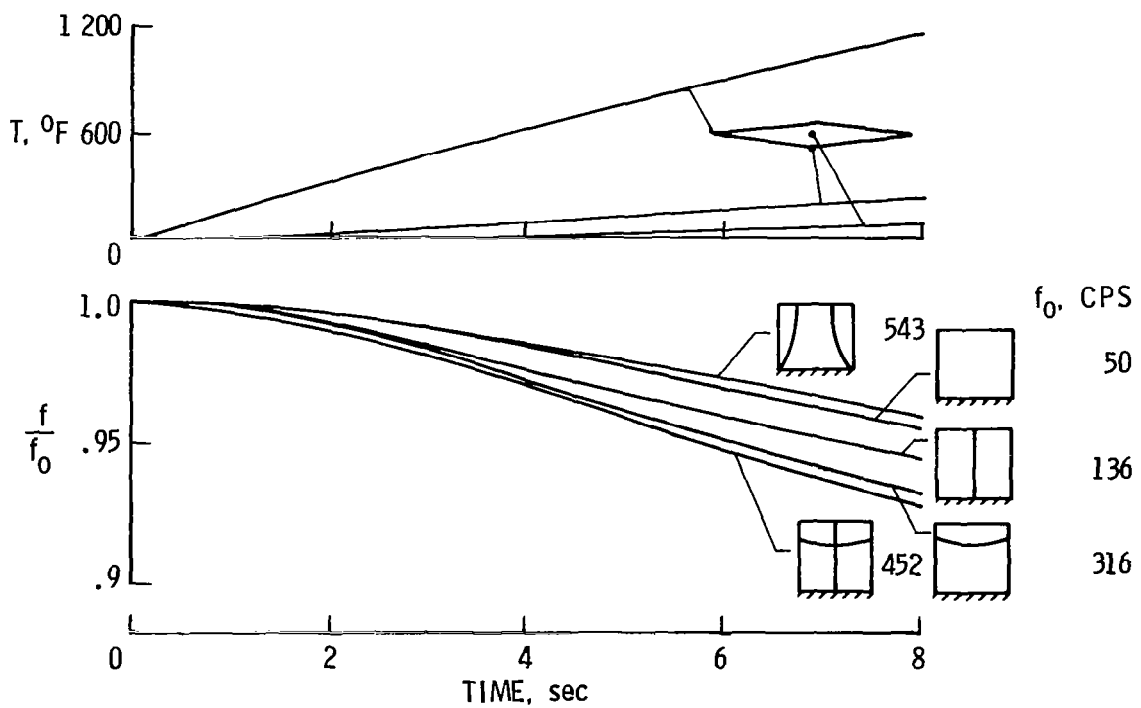

Figure 18.- Typical frequency history of double wedge wing.

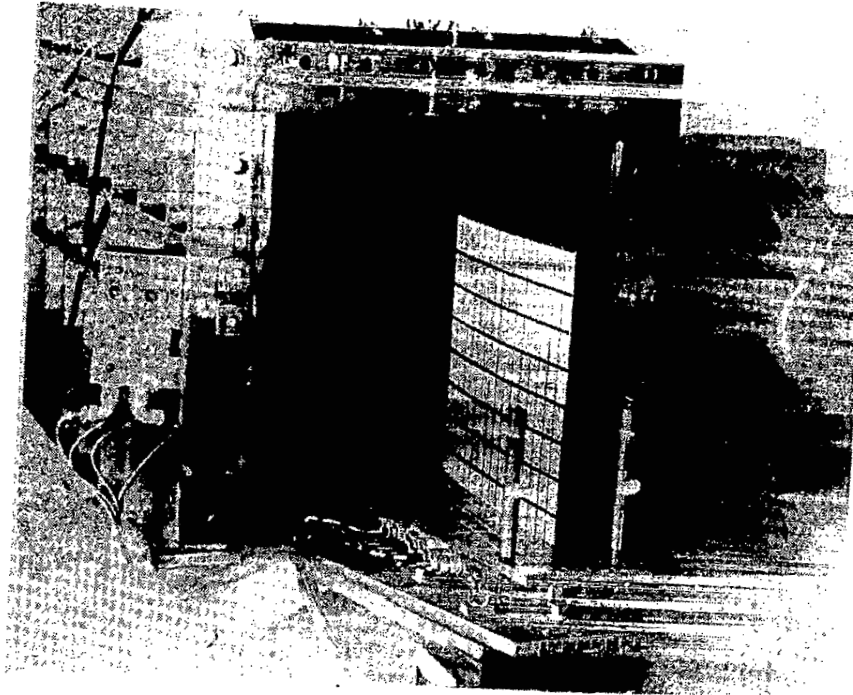

Figure 19.- Jet test of wing structure.

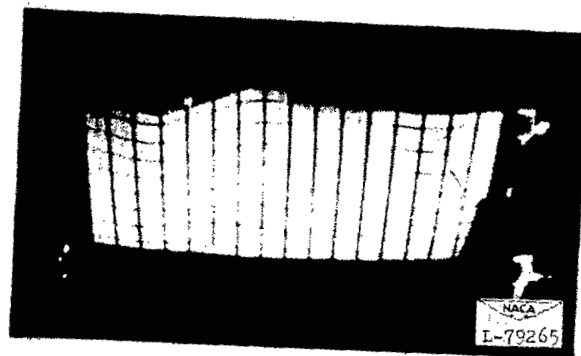
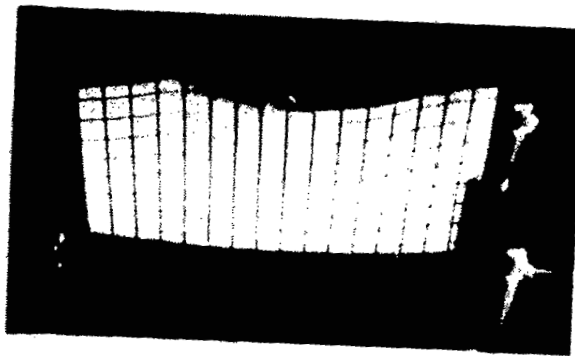

Figure 20.- Flutter resulting from stiffness changes due to aerodynamic heating.



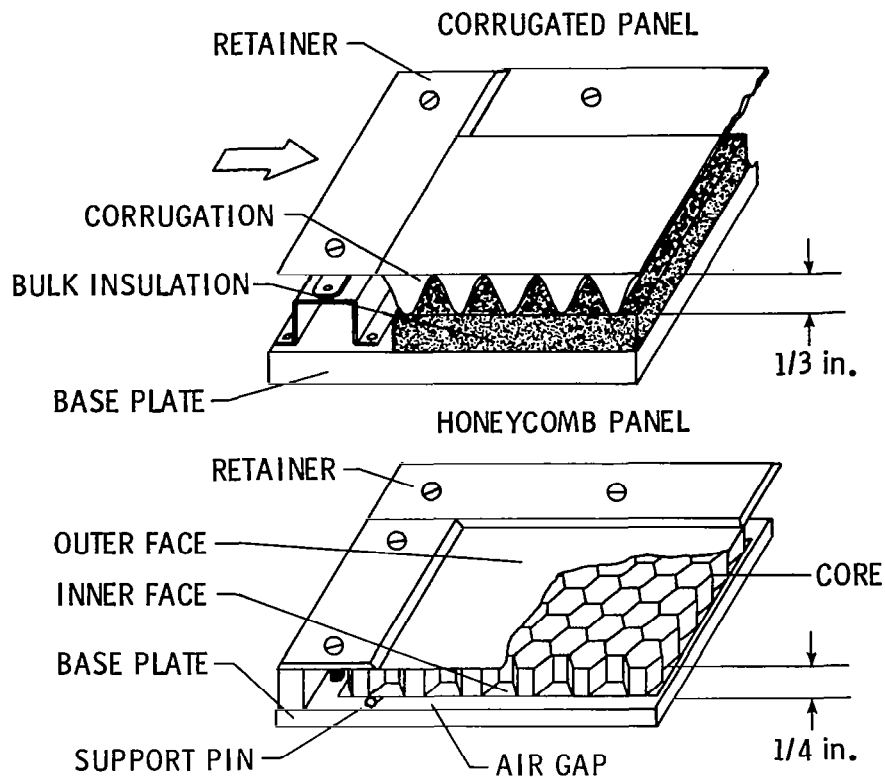

Figure 21.- Insulating panels.

● TYPES

- LOADS
- HIGH TEMPERATURES
- RAPID HEATING
- AERO-THERMO-ELASTICITY

● FACILITIES

- TESTING MACHINES
- OVENS AND FURNACES
- RADIANT HEATERS
- JETS AND WIND TUNNELS
- ROCKET MODELS
- RESEARCH AIRPLANES

Figure 22.- Structures research and facilities under development during 1955.

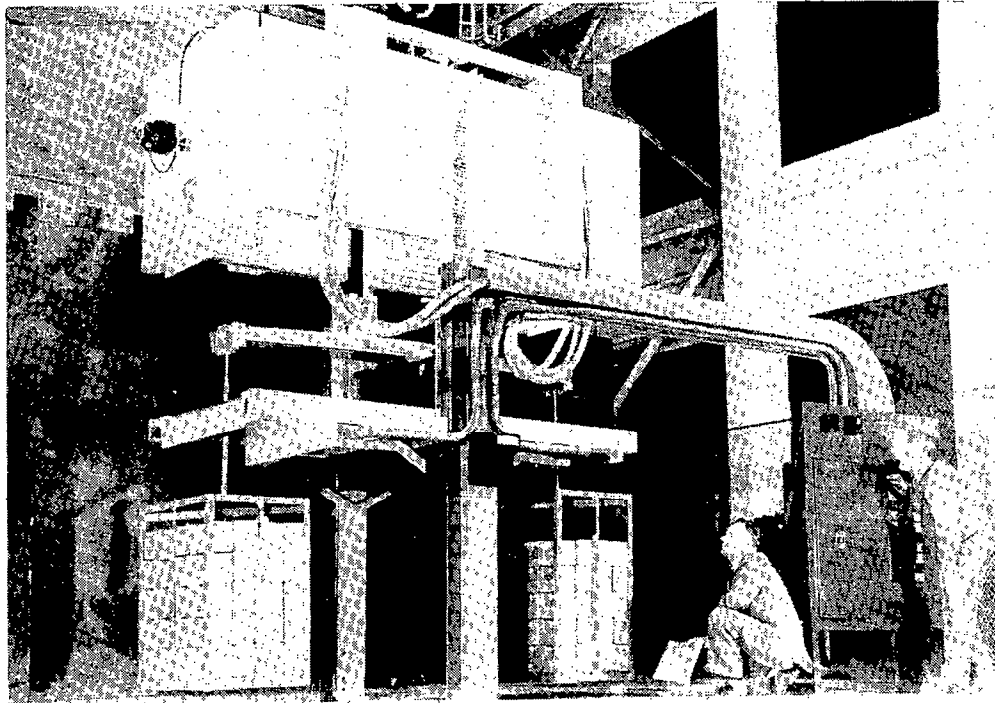

Figure 23.- Creep test equipment.

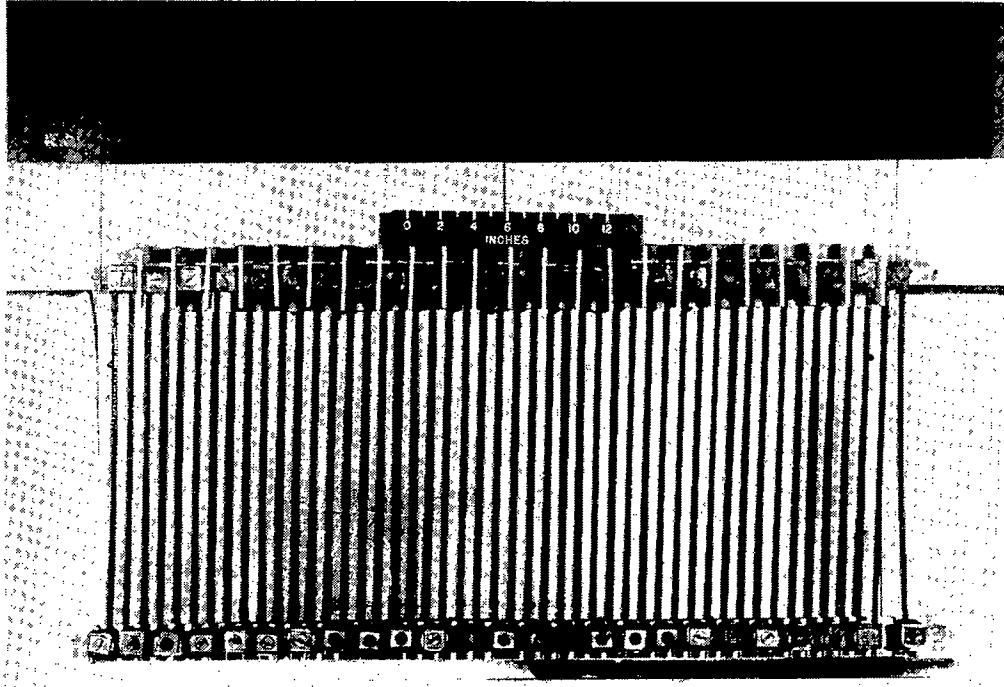

Figure 24.- Carbon-rod heat radiator.

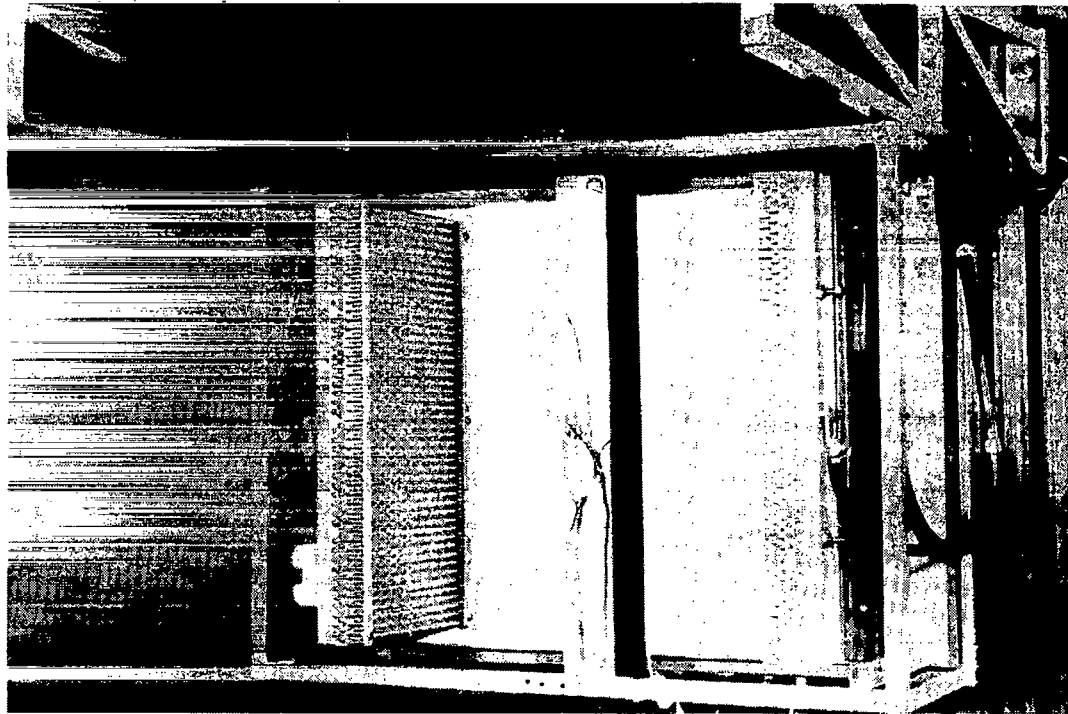

Figure 25.- Quartz-lamp heat radiators.

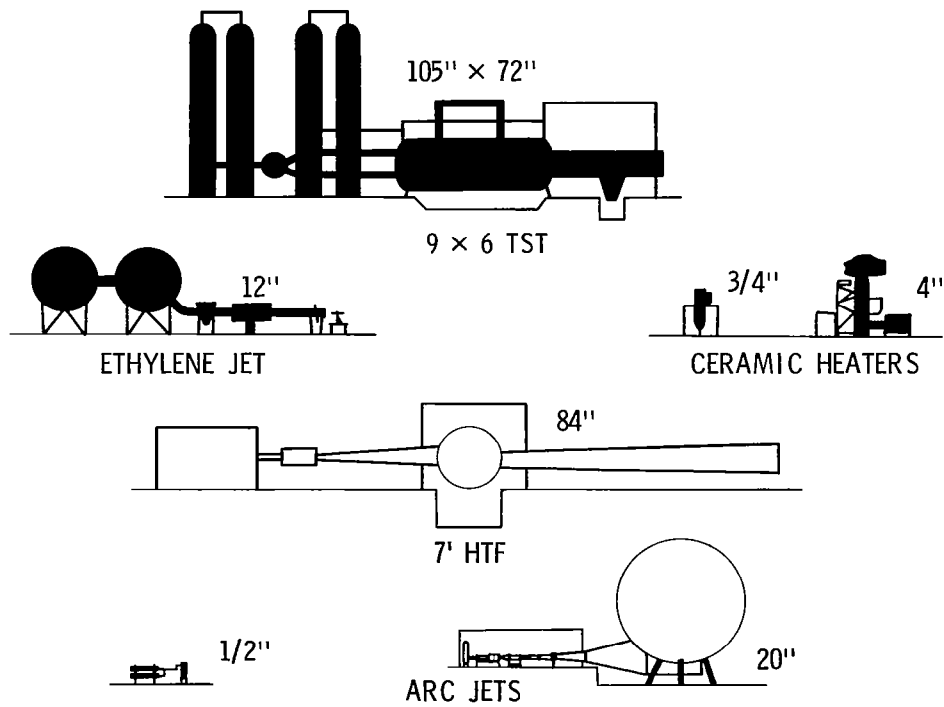

Figure 26.- Operational (black) and planned hot jets and tunnels in April 1959.

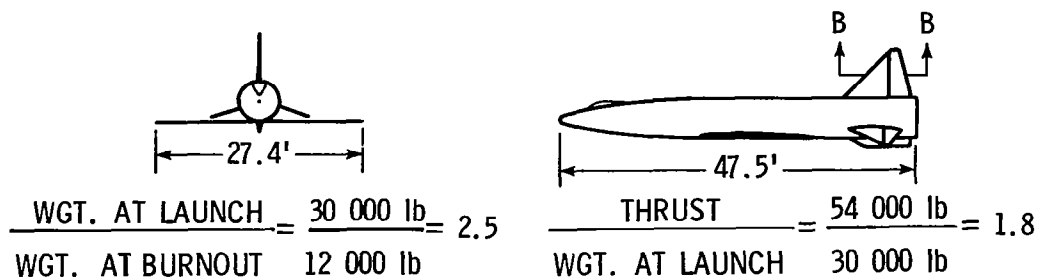
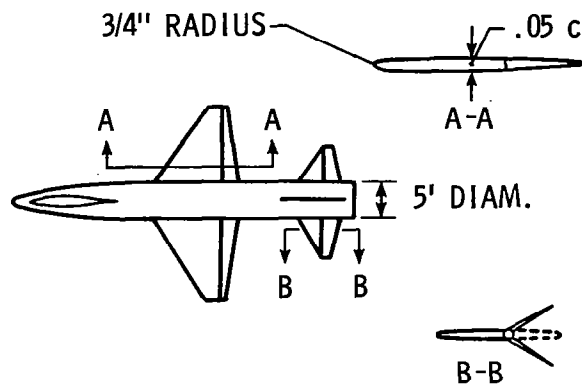

Figure 27.- Principal features of proposed X-15 research airplane defined during 1954.

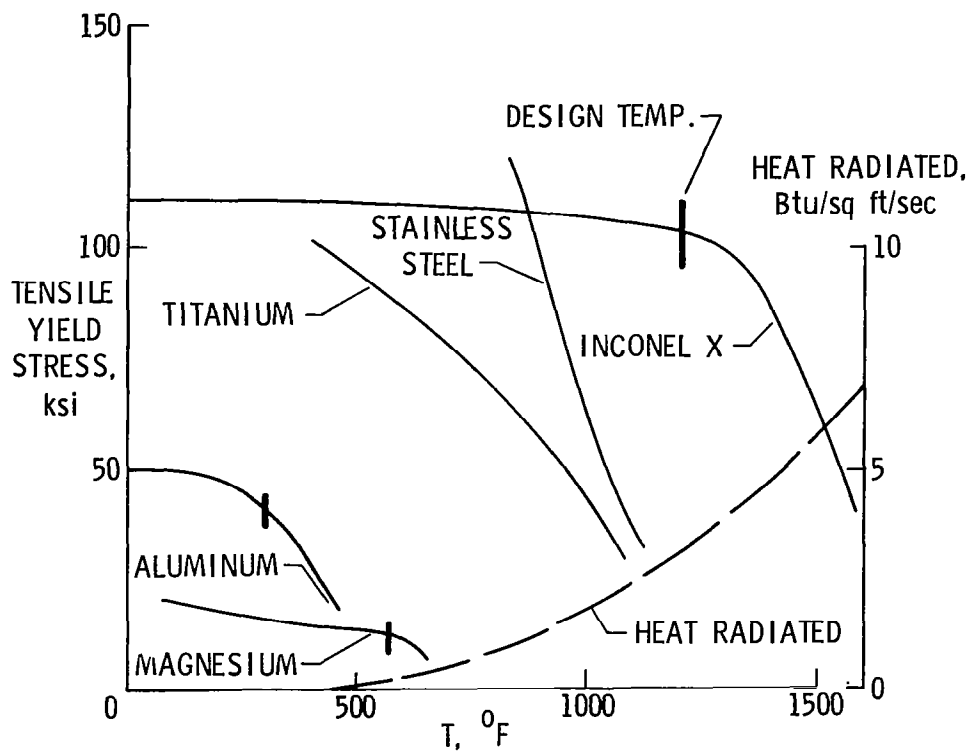

Figure 28.- Comparison of Inconel X with other candidates for X-15 applications.

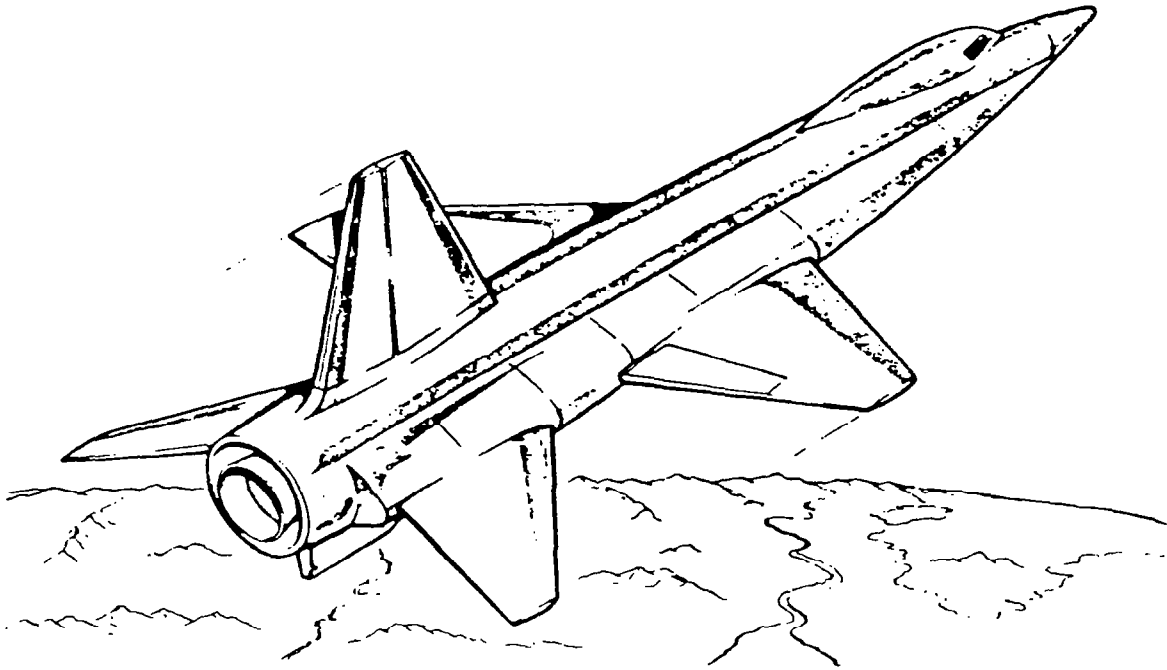

Figure 29.- North American X-15 research airplane.

SPEED DESIGN MISSION

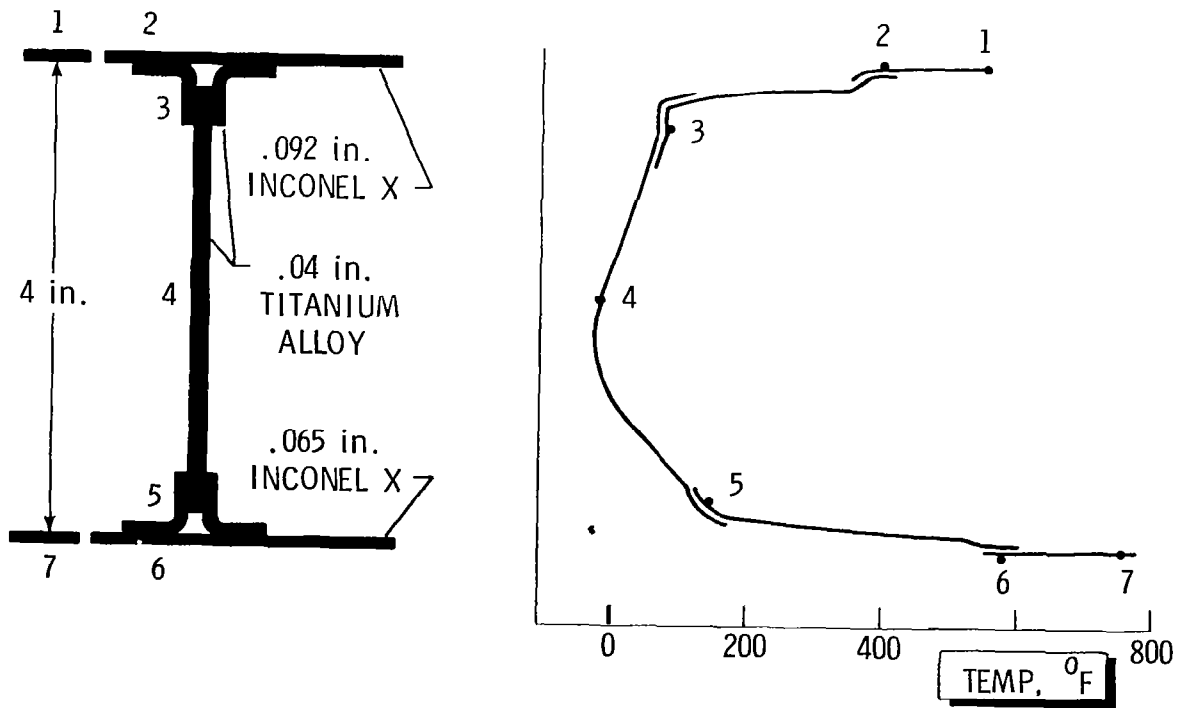

Figure 30.- Wing spar temperature calculations.

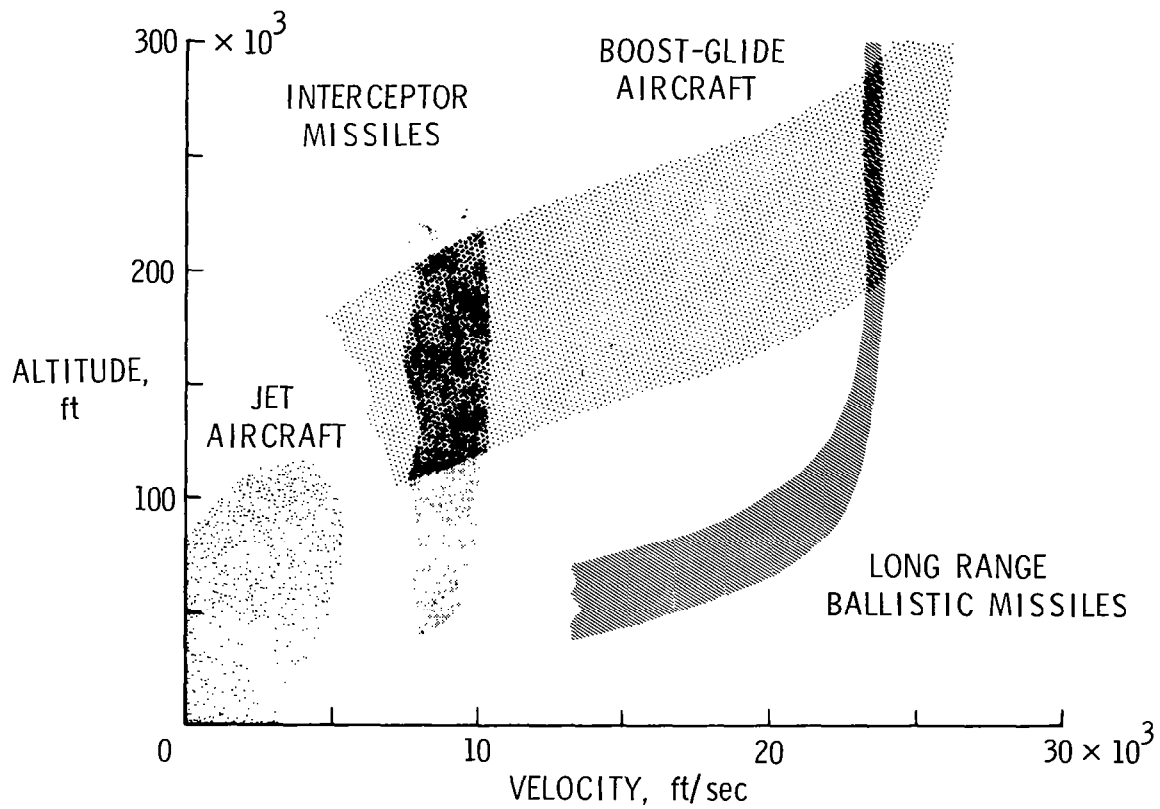

Figure 31.- Aircraft flight regions in which NACA high-temperature structures research was focused from 1948 to 1958.