

~~SECRET~~

ROTATING GRAVITY GRADIOMETER STUDY

(NASA-CR-169440) ROTATING GRAVITY  
GRADIOMETER STUDY Final Report, 1 May 1981  
- 1 Apr. 1982 (Hughes Research Labs.) 35 p  
a 104/MF A01 CSCL 14B

N83-10404

Uncias  
GJ/35 15246

Dr. Robert L. Forward  
Principal Investigator

Hughes Research Laboratories  
3011 Malibu Canyon Road  
Malibu, California 90265 USA

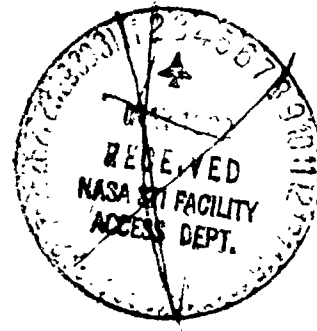

30 April 1982

FINAL REPORT

for the period from  
1 May 1981 through 30 April 1982

NASA Contract NASW-3514

National Aeronautics & Space Administration  
Headquarters, Washington, DC 20546



## SUMMARY

The two objectives of this study contract were:

1. Inspect the two government-owned rotating gravity gradiometers and determine the feasibility and cost of returning them to operating condition in a laboratory environment.
2. Determine the feasibility of applying "electronic cooling" to the existing and future rotating gravity gradiometers.

The two Rotating Gravity Gradiometer (RGG) sensors, along with all the external electronics needed to operate them, and the fixtures and special test equipment needed to fill and align the bearings, were transferred to this contract, assembled in our laboratory, and inspected. Physically, the equipment is complete and looks in operational condition. It was not possible to operate the system, however, since the punched paper tapes used to load the program into the computer were lost. New tapes can be prepared from a printed listing, but this amount of effort was not within the scope of the contract. Our conclusion concerning Task 1 is that it is definitely feasible to return the RGG sensors to operating condition in the laboratory. The estimated time is nine months and the estimated cost is \$200,000.

In previous experimental studies, we had demonstrated that the thermal noise threshold of the RGG could be lowered by replacing a damping resistor in the first stage electronics by an active artificial resistor that generates less random voltage noise per unit bandwidth than the Johnson noise from the resistor it replaces. The artificial resistor circuit consists of an operational amplifier, three resistors, and a small DC-to-DC floating power supply. These are small enough to be retrofitted to the present circuit boards inside the RGG rotor in place of the present 3 Megohm resistor. Using the artificial resistor we expect that the thermal noise of the present RGG-2 sensor can be lowered from 0.3 Eotvos to 0.15 Eotvos for a 10 sec integration time. In future models of the RGG, we would design the mechanical structure to have less mechanical damping than the present sensors and arrange to have the "electronic cooling" applied directly to the sensor through the piezoelectric pickoff transducers. This should produce a thermal noise level of 0.03 Eotvos for a 10 second integration time.



## BACKGROUND

### Introduction

One of the more important measurements that can be made of a body is a determination of the variations in its gravitational field, for gravity is one of the few measurements that give us information about the interior of the body. A detailed orbital gravity map, combined with magnetic maps and conductivity information, can determine the true bulk composition and structure of the body that lies under the bombarded surface layers contaminated with the debris of impacting meteorites. Gravity data will not only contribute to our scientific understanding of the origins of the body and its subsequent evolution, but can also be of important engineering value as we start to utilize the resources potentially available on the moon, Mars, and the asteroids.

In the past, the preferred technique for measuring the gravitational field of a body from an orbiter was to measure the Doppler variations in the tracking frequency caused by velocity variations of the spacecraft as it passed over mountains, craters, and regions of varying density. This gravity measuring technique had the advantage that it was "free", in that the tracking transponder had to be on the spacecraft for communication purposes anyway. This technique has produced good quality maps of Mars and Venus, and some good-to-excellent maps of the front side of the moon.

As we look at future missions, however, we begin to see that the Doppler tracking technique might not be adequate. For example, to obtain gravity data of the backside of the moon using Doppler tracking, it is necessary to include a relay satellite in the mission plans to provide a means to track the polar orbiter when it is over the backside. In a recent ESA study of a Polar Orbiting Lunar Observatory (POLO), the relay spacecraft weighed 154 kg and cost \$56 million. Thus, for a lunar mission, instead of being "free", the Doppler gravity experiment has the highest mass and cost of all the experiments on the mission.

In addition, since the relay satellite would be in a high orbit and the polar orbiter in a low orbit, the orbit configurations would be such that only 60% of the far side passes would be tracked by the relay. There is no "storage" of data possible in the Doppler technique. Thus to obtain a complete map of both the near and far sides would require months of dedicated ground station tracking time rigidly scheduled to cover the far-side gaps caused by the occasional poor position of the relay satellite.

We are suggesting that a new instrument, the Rotating Gravity Gradiometer (RGG) be developed for future missions. At any given altitude or distance it gives better resolution than Doppler tracking, and since its output is proportional to



the density of an object, it gives the same level of signals for a small asteroid as a large one. Since it generates measurement data internally, like all the other instruments on the spacecraft, its data can be stored and dumped along with all the rest of the science data, significantly reducing tracking and mission monitoring costs.

A contract report [14] was recently produced by Science Applications, Inc. for JPL on the feasibility and desirability of using a gravity gradiometer onboard a lunar orbiter. The report states:

"In fact, the impact due to adding the relay satellite to the mission is greater than the impact of accommodating a gravity gradiometer on the main spacecraft. The gravity gradiometer approach offers a lower total cost, less total mass to be placed in lunar orbit, and less complex operational requirements."

The report also evaluates and compares the three candidate gravity gradiometers. Table 3-1 from page 9 of that report is reproduced here.

INSTRUMENT SENSITIVITY\*

<u>INSTRUMENT</u>	<u>DEMONSTRATED SENSITIVITY, E</u>	<u>PROJECTED SENSITIVITY, E</u>
Rotating Accelerometer Gravity Gradiometer (Bell Aerospace)	1.7	0.4
Spherical Gravity Gradiometer (Draper Laboratory)	0.3	0.3
Rotating Gravity Gradiometer (Hughes)	1.0	0.1

\* Noise with a 10 sec integration time (as given in [13])

It is obvious from the conclusions of the SAI report that a gravity gradiometer instrument would be desirable for a polar orbiter lunar mapping mission and that the rotating gravity gradiometer would be the best instrument because of its higher projected sensitivity. The present model of the RGG has a residual sensitivity to axial vibrations at twice spin speed. Although this sensitivity must be designed out for earth-based systems operating in moving vehicles, it will cause no problems for an orbital gravity mapping system. The RGG, however, does need further refinement to move it out of the laboratory and bring it to the point where it can be proposed as a candidate experiment in response to some future flight opportunity.

### Rotating Gravity Gradiometer

The principle of operation of the rotating gravity gradiometer is shown in Figure 1. [1-4] The sensing structure consists of two stiff arms with weights on the ends, connected at right angles to each other by a rugged torsion pivot of high stiffness. The inertia of the two arms and the stiff spring of the pivot combine to produce a torsional mechanical resonance at 35 Hz. In operation, the sensing structure is rotated at one-half the vibrational resonant frequency (17.5 rps or 1050 rpm).

ORIGINAL FIGURE OF POOR QUALITY

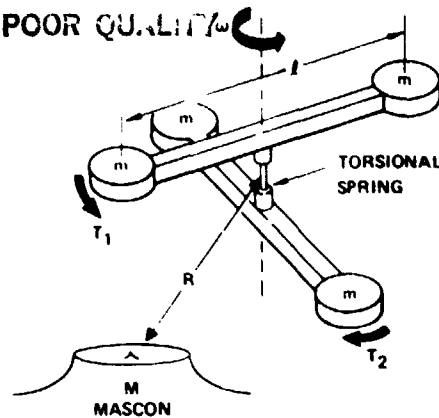

As the rotating gravity gradiometer orbits over the Moon, a mass anomaly M at a distance R causes a cross-component gravity gradient of

$$\Gamma_{xy} = GM/R^3.$$

The action of the gravity gradient field on the end masses m separated by the arm length l produces a differential torque between the two arms of the sensor given by

$$\frac{T_1 - T_2}{2} = \frac{3GMml^2}{4R^3} \sin 2(\omega t + \phi).$$

Note that the differential gravity torques are modulated at twice the rotation frequency, and thus drive the structure at its resonance. The mechanically amplified oscillations are then easily converted into electrical signals with high-sensitivity piezoelectric strain transducers. Each sensor measurement provides two pieces of data. The amplitude is proportional to the strength of the gravity gradient signal, and the phase gives the (bi)direction to the mascon.

Sensitivity. The ability of this type of instrument to detect small gravity gradient differences in a short measurement interval was demonstrated over a decade ago by Bell et al. [5]. Figure 2 shows the actual and predicted data outputs of a rotating gravity gradiometer in a test setup that simulated a spacecraft orbiting over a pair of lunar mascons. The simulation used real gravity fields from small masses moved past the sensor at the appropriate orbital angular rate. The instrument sensitivity was about 1 E (1 E=1 Eotvos= $10^{-9}$  sec $^{-2}$ =1 mGal sensitivity at 10 km). Recent advances in mechanical vibration detection techniques by Forward [6] now promise an order of magnitude improvement in sensitivity, or an equivalent reduction in size and weight.

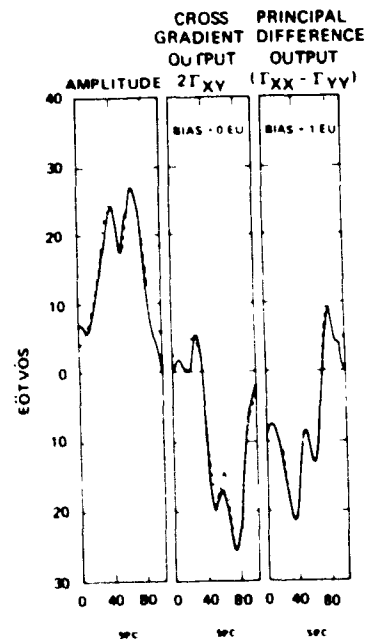

**Resolution.** The gravity gradiometer is sensitive to the derivatives of the gravity vector. For example, the vertical gradient of the vertical gravity of a point mass  $M$  at a distance  $R$  is given by:

$$\Gamma_{zz} = 2GM/R^3.$$

Because this is a component of a tensor instead of a vector, the change in the amplitude of this component of the gravity gradient tensor with horizontal separation  $x$  from the point mass is given by:

$$\Gamma_{zz}(x) = \frac{2GM}{(z^2 + x^2)^{3/2}} \left[ 1 - \frac{3}{2} \frac{x^2}{(z^2 + x^2)} \right].$$

This variation of gravity gradient with horizontal distance  $x$  is different from the variation of the gravity vector with horizontal distance, which is given by

$$g_z(x) = \frac{GM}{(z^2 + x^2)} \frac{z}{(z^2 + x^2)^{1/2}}.$$

These two equations are illustrated graphically in Figure 3, which shows that the resolution of a vertical gravity gradient measuring technique is significantly better than the Doppler velocity method for a given altitude.

**Spacecraft Operation** Despite some previous misconceptions, gravity gradiometers can be placed anywhere on a spacecraft, will operate satisfactorily at most spacecraft attitude rates presently planned, and will have only minor spacecraft interface problems. Data taken from a study we did for JPL to define a gravity gradiometer system for the Lunar Polar Orbiter [3] is shown in the following table.

**LPO Rotating Gravity Gradiometer Parameters**

- Weight: RGG: 16 kg each  
Electronics: 3 kg each
- Volume: RGG: 39 cm long by 22 cm dia = 11,400 cc  
Electronics: 37 by 15 by 8 cm = 4440 cc
- Power: 18 W plus 2 to 10 W of heater power
- Thermal: Will operate within specification 0 C to 55 C.  
Will survive without degradation -20 C to 75 C.

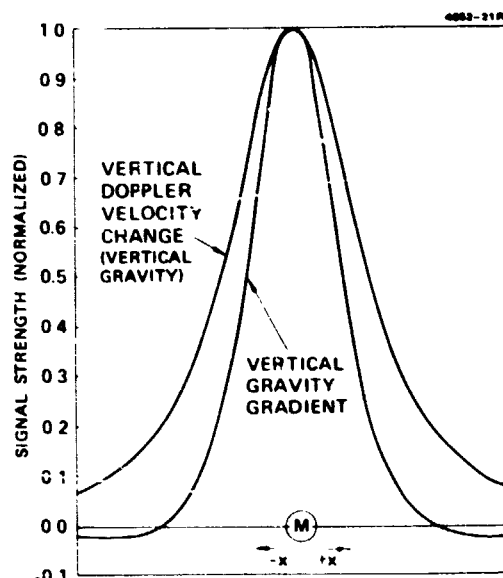

### Mapping of the Moon

Our present knowledge of the gravity of the Moon consists of significant amounts of Doppler tracking data from several lunar-orbiting spacecraft, one short surface gravity traverse, and some indirect data from lunar laser ranging experiments. The best complete map of the lunar gravity field is that of sixteenth degree and order derived by Bills and Ferrari [7] using a combination of Apollo tracking data, a high resolution surface mass model, and low-degree harmonic constraints. This model produces good agreement with known surface features and those areas of high resolution data obtained by Sjogren [8], but suffers from low resolution. The basic problem in obtaining a global gravity map of higher resolution is the lack of good gravity data from the lunar far side because the present Doppler tracking techniques are limited to line of sight from earth.

In planning future orbital surveys of the Moon, we should consider measuring the gravity field with gravity gradiometers on board the spacecraft. The gravity data from the instrument would be stored as it was gathered and dumped down periodically with the rest of the science data. The superior resolution of the gradiometer technique is demonstrated in Figure 4, taken from Forward [9, 10], where some very low altitude Apollo 16 data from Sjogren, et al. [8] was used to create a subsurface mass model that could generate simulated maps of the responses of any gravity measuring technique. The top plot in Figure 4 is a contour map of the gravity field derived from the Doppler data, while the bottom plot is a contour map of the vertical gradient of the vertical gravity. As can be seen, the gravity gradient contours can be read just as easily as the gravity contours, and they obviously have more detailed structure. This is best seen in the region on the right center of the plots, where the gravity gradient technique resolves the closely spaced collection of gravity anomalies better than the gravity derived from Doppler tracking data. By using a gravity gradiometer we will obtain such high resolution maps over the whole moon, not just in a narrow belt on the nearside.

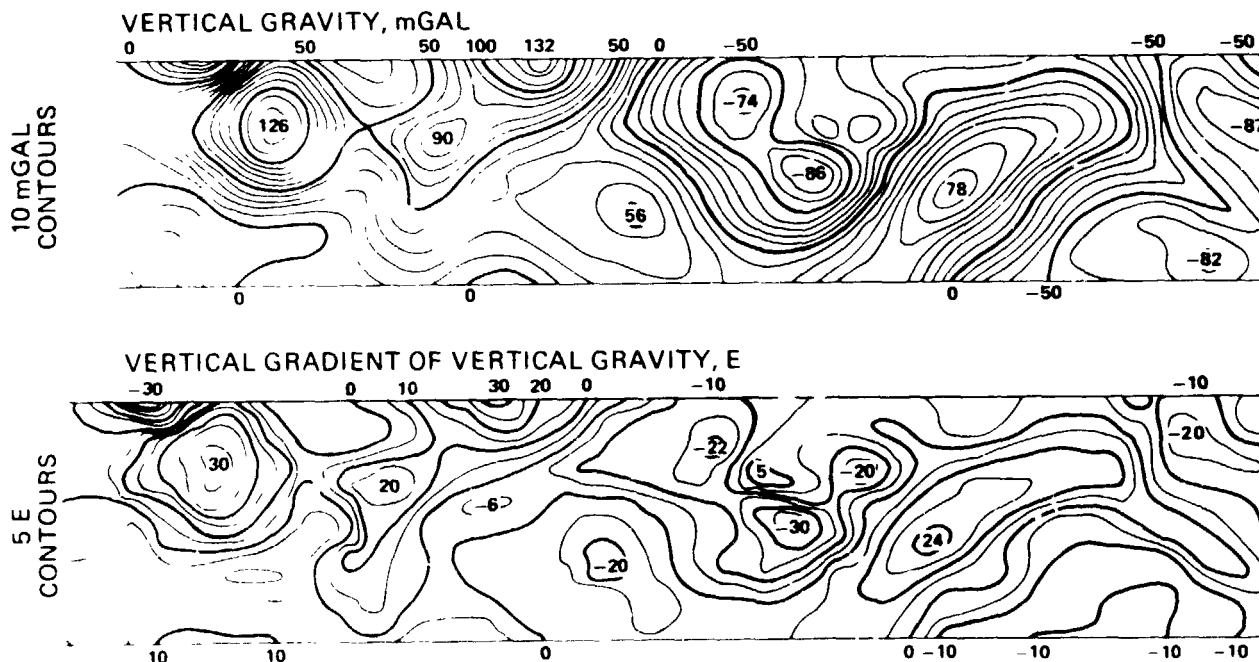

**Gravity Mapping of Asteroid and Comets**

Because the gradiometer works as well with small bodies as large ones, it is the preferred technique for gravitational mapping of asteroids and comets.

To obtain a mass distribution map of a small body, it would be desirable to put the spacecraft in a close orbit about the body. The type of data that can be obtained this way was modeled by Forward [11], who compared data from both Doppler tracking systems and gravity gradiometers for a spacecraft in orbit about a simulated asteroid. Figure 5 shows the mass model of a hypothetical asteroid that was used in the computer simulations. The asteroid is 100 km in radius and has an average density of 3.5 g/cc.

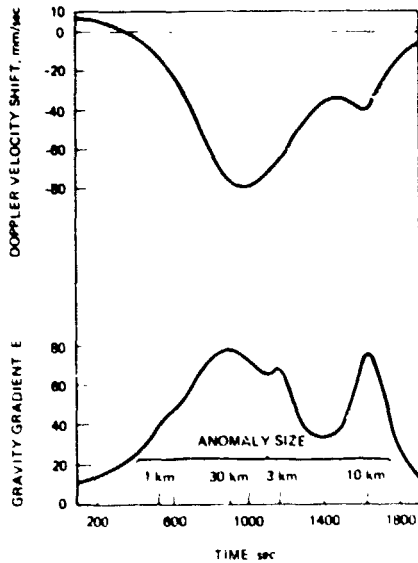
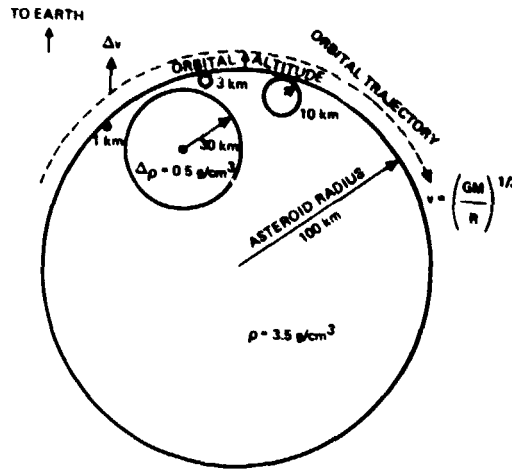

Embedded in this asteroid are spherical mass anomaly regions with radii of 1, 3, 10, and 30 km and a density difference of +0.5 g/cc. If the orbiting vehicle is 3 km above the surface, then the output of the Doppler tracking system and the gravity gradiometer system during the passage over the anomalies is as shown in Figure 6. If we assume that the sensitivity of the Doppler tracking system is 1 mm/sec and the gravity gradiometer system is 1 Eotvos, then as can be seen in the figure, the two techniques are equally good on the large mass anomalies, such as the 30 km inclusion, but the gradiometer technique provides higher signal level and better resolution on the smaller anomalies.

The major advantage of the gradiometer technique over the Doppler technique is shown in Figure 7 where we have assumed a decrease in scale of the simulation by a factor of 10. Instead of a spacecraft in an orbit 3 km above a 100 km asteroid with 1 to 30 km sized anomalies, we have simulated a spacecraft in an orbit 300 meters above a 10 km asteroid with 100 to 3000 m sized anomalies. The orbital period has not changed, because the asteroid density is assumed to be the same, so the time required for each measurement point is the same. The gravity gradient signal has the same magnitude and resolution for the 10 km asteroid as it did for the 100 km asteroid, but the Doppler velocity signal has decreased by an order of magnitude.

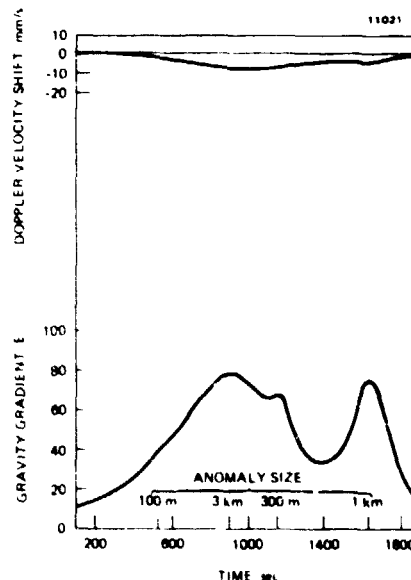

## INSPECTION AND EVALUATION OF RGG INSTRUMENTS

At the start of this contract it was assumed that only the RGG sensor heads were in government storage. The two sensors, RGG-1S and RGG-2, were residual inventory from a series of Air Force and Navy contracts for the development of a gravity gradiometer usable in a moving vehicle on the surface of the earth. The RGG sensors contain all the critical mechanical subsystems as well as some internal signal pre-processing and engineering electronics. To operate these sensors, however, requires a relay rack of electronics containing a mini-computer, various power supplies and monitoring instruments, and some specialized signal processing circuits. It was thought that the two sets of external electronics had been sold or given away as surplus, leaving only the two RGG sensors.

In May 1981, the two gradiometers were transferred from the Air Force and Navy to this contract and delivered to our laboratory. cursory inspection showed that the older RGG-1S is missing its cables and the cover to the photodiode pickoff. Replacing the missing cables and cover would be a minor problem. The newer RGG-2 was complete with its magnetic shield and all of its cables. In June 1981, an estimate was made of what it would cost to restore one of the gradiometers, the newer RGG-2, to operating condition. The estimated cost was \$680,000 including a subcontract of \$448,000 to reproduce the external electronics.

On 25 August 1981, the principal investigator was contacted by Prof. D. Anderson of the University of Washington, who inquired about the condition of a Prime 200 computer on a government surplus list. Acting on this information a trip was made on 1 September 1981 to a local government surplus storage facility. In the facility were found the two sets of electronic equipment needed to make both RGG sensors operational, plus additional specialized mechanical and electronic units used in calibration of the sensors and for filling and adjusting the sensor bearings.

Because part of the surplus equipment was Air Force property and part was Navy property administered by Sperry Systems Management, it took a number of months before the external electronics and the miscellaneous equipment could be transferred to this contract. The equipment was finally physically delivered to our laboratories on 31 January 1982. A list of all the equipment transferred to this contract is given in Appendix A. As a result of this "find", the estimated cost of restoring one of the gradiometers to operating condition was reduced to \$200,000. The time needed was estimated to be nine months.

Physically, the equipment is complete and looks in operational condition. It was not possible to operate the system, however, since the punched paper tapes used to load

the program into the computer were lost. One tape contained the "boot" routine, one contained the operating system for the Prime 200 computer, and the third contained the program needed to run the RGG sensor. The program is mostly in Fortran, with some time-critical sections written in assembly language. The "boot" and a Prime 200 compatible operating system with a Fortran compiler can be obtained from many sources, including the manufacturer of the Prime computer and some Prime 200 users inside Hughes. A printout of the Fortran and assembly language program needed to run the RGG is printed as Appendix G in Volume 4 of the final report of our previous Navy contract [4]. This program can be retyped into a computer and a new paper tape made, but this amount of effort was not within the scope of this contract.

## FEASIBILITY OF APPLYING ELECTRONIC COOLING

In previously published experimental studies of electronic cooling of resonant gravity gradiometers [6], we had demonstrated that the thermal noise threshold of an RGG sensor could be lowered by replacing the damping resistor in the first stage electronics by an artificial resistor.

The present RGG sensor structure, by itself, has an initial mechanical  $Q$  of about 1500. Since the resonant frequency of the structure is 35 Hz, this results in a  $1/e$  decay time of 14 sec. This high  $Q$  is brought down to a value of 300 by means of an electrical damping resistor of 3 Megohms placed across the two piezoelectric pickoff transducers operated in series. The resultant decay time of about 2.7 sec gives a reasonable sensor response time to rapidly changing signals. Since the addition of the 3 Megohm resistor causes a factor of five decrease in the mechanical  $Q$ , that means that the 3 Megohm resistor contributes 80% of the damping and thermal noise, while the mechanical losses, with an effective damping impedance of 0.6 Megohms, contribute 20%.

To carry out the experimental demonstration of electronic cooling, we had to lower the  $Q$  of the RGG structure to a  $Q$  of 7 in order to widen the sensor bandwidth to 5 Hz. This was necessary since the sensor bandwidth had to be larger than the 1 Hz bandwidth of our spectrum analyzer. We had to use a damping resistor of 110 Megohms to achieve this level of damping, and had to construct a 110 Megohm artificial resistor to demonstrate the electronic cooling. Using this 110 Megohm artificial resistor, we demonstrated an improvement of 8.3 dB in signal-to-noise power ratio over the signal-to-noise obtained with the standard passive dissipative 110 Megohm resistor. The effective noise temperature of the "electronically cooled" sensor in this experiment was 44 K. This decrease of effective noise temperature is equivalent to a reduction of the sensor noise by a factor of 6.8 in power or 2.6 in amplitude. Thus the thermal noise in the RGG structure used in this test was reduced from 0.3 Eotvos to 0.2 Eotvos for a 10 sec integration time. Since the 110 Megohm electrical damping was much larger than the 0.6 Megohms of mechanical damping, nearly all of the noise seen in both signal-to-noise measurements came from the passive or active electrical resistors, not the mechanical damping.

Artificial resistors with such high values of equivalent resistance are hard to construct while maintaining low effective temperatures. Based on this experimental data at 110 Megohms, we expect that if we construct an artificial resistor with an effective resistance of only 3 Megohms, and use some of the newer operational amplifiers such as the OP-27 that has ten times less voltage noise than the LM-308 operational amplifiers that we used, then we can expect to obtain a 3 Megohm artificial resistor with an effective



ORIGIN  
OF

temperature of less than 20 K. This artificial resistor will contribute 80% of the noise or 16 K, while the mechanical damping of the room temperature structure will contribute 20% of its 300 K noise or 60 K, producing an effective sensor temperature of 76 K. This factor of 4 improvement in noise power or a factor of 2 in noise amplitude will reduce the thermal noise contribution of the existing RGG-2 sensor structure from 0.3 Eotvos to 0.15 Eotvos for a 10 sec integration time.

The cold electronic circuit that we would use will not be the ones used in the electronic cooling paper [6], since these involved using one transducer as a pickoff and the other transducer for feedback.

We would not want to change the present wiring of the transducers, which have the transducers wired in series with a 3 Megohm resistor across the terminals. Instead, we will use an artificial resistor circuit described in our recent patent [12] that consists of an operational amplifier, three resistors, and a floating power supply.

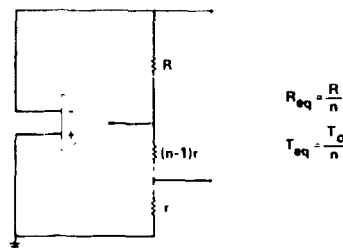

(See Figure 9.) DC-to-DC converters to make a floating power supply now exist as a single module the size of a typical integrated circuit, thus the four components to make the artificial resistor are small enough to be put on the present circuit boards inside the RGG rotor in place of the present 3 Megohm resistor.

In future models of the RGG, we would design the mechanical structure to have less mechanical damping than the present sensors (a Q of 100,000) and have a different piezoelectric transducer arrangement. As shown in Figure 10, the electronic damping would be applied between a pickoff transducer and a feedback transducer.

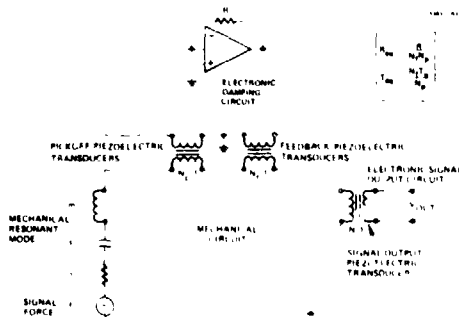

In Section V of the electronic cooling paper [6], we calculate that if we design a 120:1 ratio of feedback coupling to pickoff coupling and a 1000:1 ratio of electrical damping to mechanical damping (lowering the Q from 100,000 to 100), then the equivalent temperature for the combined system is predicted to be 3 K. This factor of 100 in noise power and 10 in noise amplitude will produce a RGG sensor with a thermal noise contributor of 0.03 Eotvos for a 10 sec integration time.

## FUTURE INSTRUMENT DEVELOPMENT PROGRAM

To produce a gradiometer suitable for a lunar mission, we propose starting from the existing hardware, and build on that experience as we prove that the present design will satisfy the mission requirements for the moon. For the first phase of the program, we would reprogram the computer, check out the external electronics, and determine the condition of the existing RGG-2 sensor head. This part of the program is estimated to cost \$200,000 and take nine months.

At the completion of this program we expect to show that the sensor has survived the storage period without degradation in performance. It should show a short term noise level of 1 Eotvos or less when it is sitting on a quiet pier with its spin axis vertical, and should have a long term drift of less than 5 Eotvos per hour drift using its built-in temperature controller. Figure 11 illustrates the performance of the RGG-2 before it went into storage.

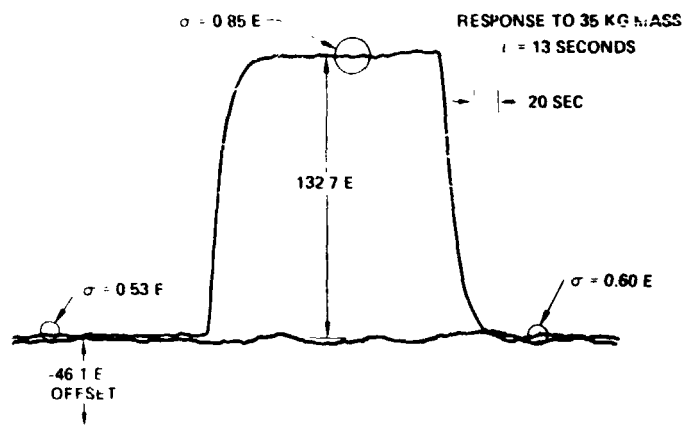

If the RGG-2 does not show this quality of performance, then it will be necessary to carry out a diagnostic effort to determine the cause. We will then propose a short program to repair the problem and return the instrument to its original level of performance.

We expect that RGG-2 will operate satisfactorily and we will then want to proceed to the next phase, that of producing a flight prototype based on the present design. There might be some concern, however, that although the design is suitable for operation on earth, it would not perform as well in space. From the design, one would expect that free-fall would improve the performance, since the sensor and bearings would not be subjected to the one-gee force of the earth's gravity. But if it is desired to check out the instrument in free-fall, then the existing RGG-2 sensor is probably adequate for these tests. The RGG-2 mechanical portions can take a 50 gee load, so the instrument would have no trouble surviving a launch. The external electronics, however, would have to be repackaged for space operation.

If it is desired by NASA that there be a checkout in free fall, then the next phase of the program would be to simplify the external electronics design by eliminating the diagnostic

ORIGIN  
OF FOOTNOTES

features and making the system autonomous in operation. The new space-qualified electronics and the existing sensor can then be checked out in free fall in a vertical rocket test or in a "Get-Away Special" canister on the Shuttle. This portion of the program would probably cost \$1 million and take another 12 to 18 months, depending upon launch availability. It should be recognized that we do not recommend this phase, but it is one that would eliminate one last area of risk. We recommend instead that we proceed directly to the design and verification of a flight prototype.

The present design for the RGG is six years old, and the design was optimized for the airborne earth survey application. The sensor is heavy and uses lots of power. For the next phase we recommend that the entire present design, including the mechanical portions and the internal electronics, be reexamined in light of the potential NASA orbital uses. A redesign should reduce the weight, size and power by significant factors, while maintaining the present design features and possibly even improving the threshold sensitivity. In order to verify the redesign, we would want to follow the procedures that are used to verify the design of any new inertial instrument. We must build three to five models of the flight prototype design and then compare their performance. One model is not enough. If a single model of an instrument works, we do not know whether the redesign was good and every time we build one we will get similar performance, or whether we were lucky with that one and none of the flight models built using the same prints will work. If the single model does not work, we will not know whether it was a flaw in the design or an unfortunate mistake in the fabrication.

With three flight prototypes, we can run detailed comparison tests of their relative performances under various environments of noise, magnetism, and acceleration, and can put real limits on their sensitivity. We can also be running life and environmental tests on one or two models while the other is undergoing any modifications that are felt suitable. This phase is expected to take two years and cost \$2-3 million dollars. At the end of it, we would have a firm design for a flight model that could be proposed for some specific mission.

The next phase would depend upon the mission. For a lunar orbiter mission, a good gravity map could be obtained with one RGG oriented in the proper direction. The data from one sensor might be hard to analyze, however, so most people have recommended at least two RGG sensors for the lunar mapping mission. One sensor would be oriented to measure the gravity gradients along the orbital track, and another to measure the gravity gradients across-track. The across-track data will tie the data from different orbits together, improving the accuracy of the data reduction. The ideal sensor system would be three RGG sensors in an orthogonal

array. These would measure the total gravity gradient tensor and allow the separate determination of spacecraft angular rates. This would give not only a complete gravity map for geophysical use, but also an extremely accurate reconstruction of the spacecraft orbit, which will help in the reduction of the data from all the other sensors onboard the spacecraft. The cost of flight models and spares will depend greatly on the mission, the spacecraft constraints, and the design that was produced in the flight prototype phase. From extrapolations of previous experience, it is expected that the flight instrument sensor heads will cost \$500,000 each plus \$2-3 million for the electronics and system integration, with three instruments being almost as easy to integrate as one.



## BIBLIOGRAPHY

1. R.L. Forward, "Gravitational Mass Sensor", Proc. 1963 Symposium on Unconventional Inertial Sensors, Farmingdale, NY (18-19 Nov 1963).
2. R.L. Forward, "Research on Gravitational Mass Sensors", Final Report, NASW-1035, NASA Headquarters, Washington, DC, (15 Oct 1964 through 15 April 1966).
3. R.L. Forward, R.M. Lemmen, R.W. Lowe, R.W. Peterson, I. Tonai, and W.E. Williams, "Rotating Gravity Gradiometer Study", Final Report, JPL Contract 954309 (Aug 1975 through June 1976).
4. "Gravity Gradiometer Instrument (GGI) Feasibility Demonstration and Studies and Gravity Gradiometer System (GGS) Definition Studies Program", Final Report on Sperry Systems Management P.O. P170614 under Navy prime contract N00030-77-C-0119, Sperry Systems, Great Neck, NY (April 1978). (esp. see volume four - E0634-004 "Gravity Gradiometer Instrument (GGI) Analyses and Studies Report.)
5. C.C. Bell, R.L. Forward, and H.P. Williams, "Simulated Terrain Mapping with the Rotating Gravity Gradiometer" Proc. Symposium on Dynamic Gravimetry, Fort Worth, Texas (16-17 March 1970), pp 115-128 of Advances in Dynamic Gravimetry, W.T. Kattner, ed., Instrument Soc. America Publication, Pittsburgh, PA (1970).
6. R.L. Forward, "Electronic Cooling of Resonant Gravity Gradiometers", J. Appl. Physics 50, 1-6 (Jan 1979).
7. B.G. Bills and A.J. Ferrari, "A Harmonic Analysis of Lunar Gravity", J. Geophysical Res. 85, 1013-1025 (1980).
8. W.L. Sjogren, R.N. Wimberly and W.R. Wollenhaupt, "Lunar Gravity via the Apollo 15 and 16 Subsatellites", The Moon 9, 115-128 (1974).
9. R.L. Forward, "Gravity Gradient Mapping from the LPO - Science Return Simulation", The Moon 29, 3-26 (July 1976).
10. R.L. Forward, "Future Lunar Gravity Measurements", The Moon and Planets, 22, 419-433 (June 1980).
11. R.L. Forward, "Asteroid Mass Distribution Measurement with Gravity Gradiometers", Proc. 21st Coll. of the IAU, Tucson, Arizona (6-10 March 1971), pp 585-593 of Physical Studies of the Minor Planets, T. Gehrels, ed., NASA SP-267 (1971).
12. R.L. Forward and G.D. Thurmond, "Network for Simulating Low-Noise-Temperature Resistors," U.S. Patent 4,176,331, issued 27 November 1979.
13. W.C. Wells, "Gravity Gradiometers and the POLO Mission," Summary of a Workshop at NASA Headquarters, 14-15 Jan 1981. Science Applications, Inc., Schaumburg, IL (May 1981).
14. W.C. Wells, "Lunar Gravity Gradiometers: An Assessment of Feasibility and Development Requirements," Report No. SAI 1-120-937-S13, Science Applications, Inc., Arlington, VA, Final Report, Contract 955630, Jet Propulsion Lab, Pasadena, CA (December 1981).

PRECEDING PAGE BLANK NOT FILMED



APPENDIX A

LIST OF EQUIPMENT

The following items of hardware were assigned to this contract:

ID Number	Quant.	Identification
G-123553	1	Rotating Gravity Gradiometer RGG-2, HRL
G-123554	1	Rotating Gravity Gradiometer RGG-1S, HRL
G-123504	1	Computer, Prime 200, with four boards
		Type                    Model    SN    Slot
		Memory (large) 1216-B85    684    17
		CPU                    2223-360    1755    15
		GP Interface            7010    106    13
		TTY I/O                  3001    936    11
G-123502	1	Power Supply, HP 6438B
G-123503	1	Power Amplifier, Crown DC300A
G-123505	1	Oscilloscope, Tektronix SG502
G-123506	1	Instrument Main Frame, Tektronix RTM-506
G-123509	1	Digital Multimeter, Tektronix DM501
G-123515	1	AC Line Conditioner, Elgar 6000B
G-123516	1	Relay Rack, Emcor IE-203
G-123518	1	Computer I/O Buffer, HRL
G-123519	1	Speed Controller, HRL
G-123521	1	Signal Conditioner, HRL
G-123524	1	Temperature Controller, HRL
G-123542	1	Power Supply, HRL
G-123537	1	Computer, Prime 200, with five boards
		Type                    Model    SN    Slot
		Memory (small)          271    270    10
		Memory (small)          271    055    9
		CPU                    2222-250    1055    8
		GP Interface            7000    294    6
		TTY I/O                  3003    203    4
G-123517	1	Temperature Controller, HRL
G-123538	1	Power Panel Prime 240
G-123540	1	Punch Tape Reader, Remex 107SBCI/660
G-123541	1	Power Supply, HRL
G-123545	1	Motor Power Unit, HRL
G-123546	1	Signal Conditioner, HRL
G-123547	1	RF Power Supply, HRL
G-123548	1	Computer Buffer I/O, HRL
G-123550	1	Accelerometer Switch Panel, HRL
G-123544	1	Motor Drive, HRL
G-123551	1	Vibration Control Panel, HRL
G-123552	1	Computer Power Supply, AmPower PC-3
G-123543	1	Heater Power Supply, HRL
G-123549	1	Signal Conditioner, HRL
G-123570	1	Bearing Fill Fixture, Tri Precision

PRECEDING PAGE BLANK NOT FILMED



G-119195	1	Micrometer, Mitutoya 519-124
G-119200	1	Micrometer, Mitutoya 519-124
G-119190	1	Vacuum Pump, Welch 1400B-01
G-119156	1	Proximeter, Bently Nevada SN 71759
G-119191	1	Proximeter, Bently Nevada SN 88683
G-123539	1	Teletypewriter, Teletype 3320-5JE
G-123569	1	Differential Accelerometer Bar containing Accelerometer, Bell VIIB SN469H6 Accelerometer, Bell VIIB SN408E6
X2909-99	2	Alignment Dowel
X2909-98	1	Holder
X2909-97	12	Alignment Pin
740587	1	Sensor Mounting Adapter
740586	1	Sensor Mounting Plate
740549	1	Differential Accelerometer Mounting Bracket
740593	1	Dynamic Balance



---

# **GRAVITATIONAL SCIENCE**

## **FROM THE**

### **POLAR ORBITING LUNAR OBSERVATORY**

---

**PRESENTATION AT THE  
GRAVITY GRADIOMETER WORKSHOP  
NASA HEADQUARTERS, WASHINGTON, DC  
14-15 JANUARY 1981**

**DR. ROBERT L. FORWARD  
SENIOR SCIENTIST  
HUGHES RESEARCH LABS  
3011 MALIBU CANYON ROAD  
MALIBU, CA 90265 U.S.A.  
(213) 456-6411 X 280  
(805) 487-2517 HOME**

# GRAVITY FORCES NEAR A MASS ANOMALY

**HUGHES**  
HUGHES AIRCRAFT COMPANY  
RESEARCH LABORATORIES

$$g = - \frac{GM}{R^2}$$

3874-3

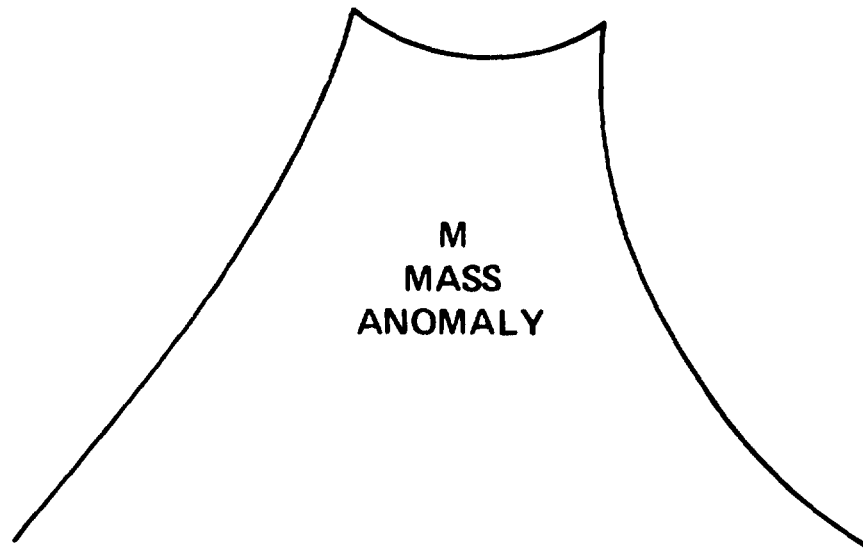
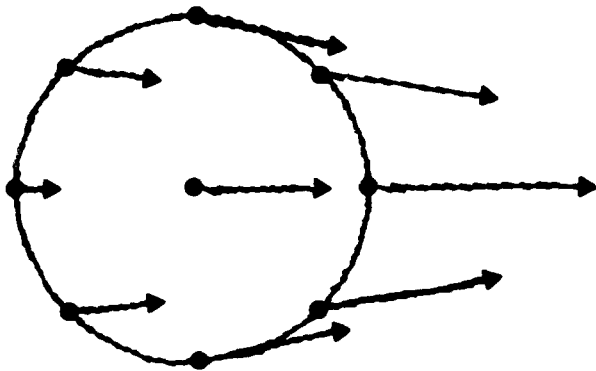

ORIGINAL SOURCE IS  
OF POOR QUALITY

# GRAVITY GRADIENTS NEAR A MASS ANOMALY

**HUGHES**  
HUGHES AIRCRAFT COMPANY  
RESEARCH LABORATORIES

4806-10

$$\frac{\partial g}{\partial R} = \frac{2 GM}{R^3}$$

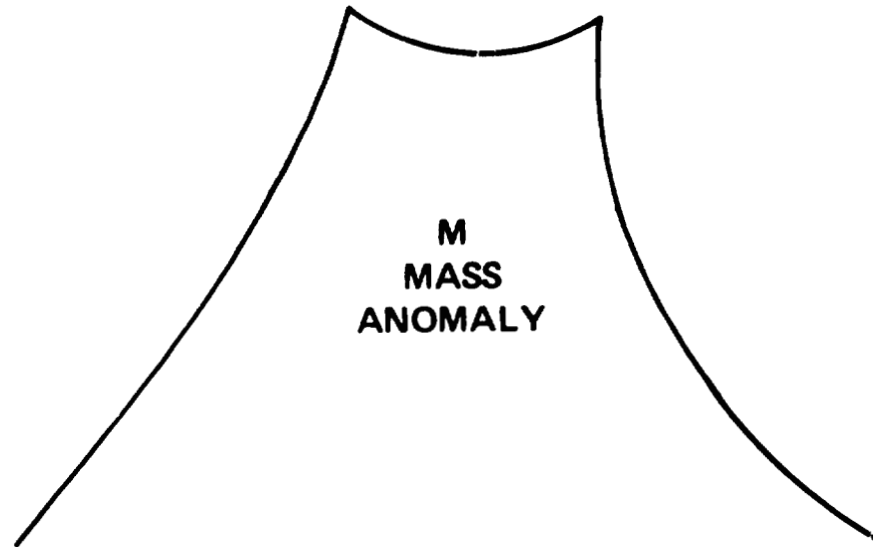
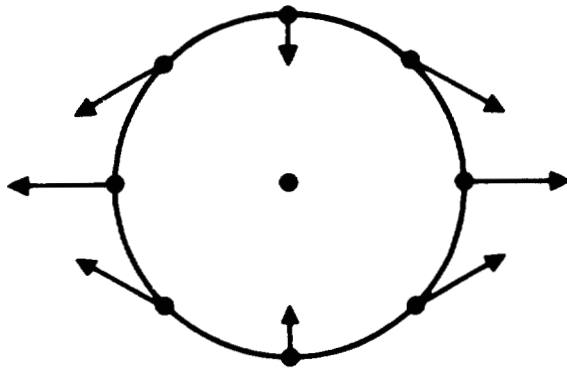

# PRINCIPAL CHARACTERISTICS OF ROTATING GRAVITY GRADIOMETER



4806-9

- SENSES GRADIENT TORQUES
- CANCELS ACCELERATION MECHANICALLY
- SELF REFERENCING TORQUE SENSING
- "TAGS" GRADIENT SIGNAL BY ROTATION MODULATION
- "NOISELESS" PREAMPLIFICATION USING RESONANCE

OF 10

# RGG CHARACTERISTIC GRADIENT TORQUE SENSING



4806-1

## RGG DESIGNED TO SENSE GRADIENT TORQUES

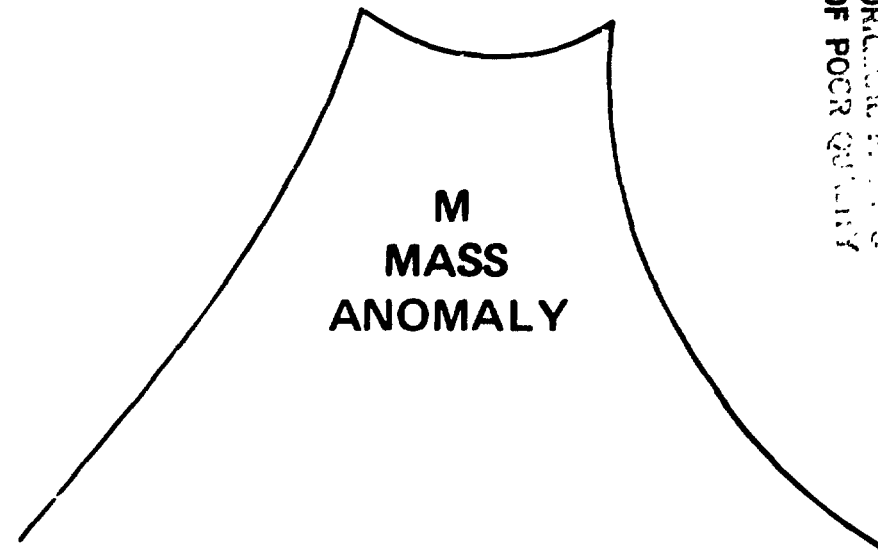
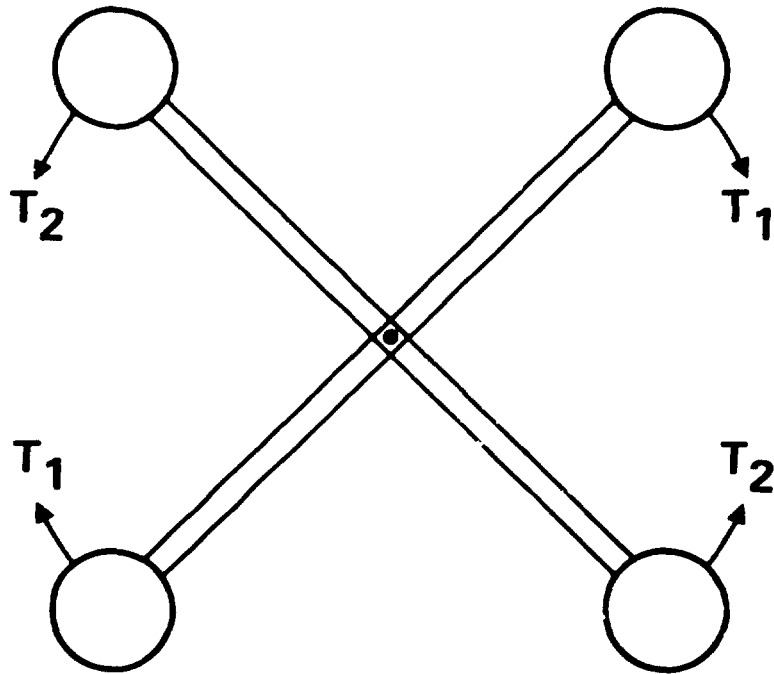

# RGG CHARACTERISTIC MECHANICAL FORCE DIFFERENCING

**HUGHES**  
HUGHES AIRCRAFT COMPANY  
RESEARCH LABORATORIES

3874-B

MEASURING SMALL  
GRADIENTS REQUIRES EXTREME  
( $10^{-11}$ ) LINEARITY

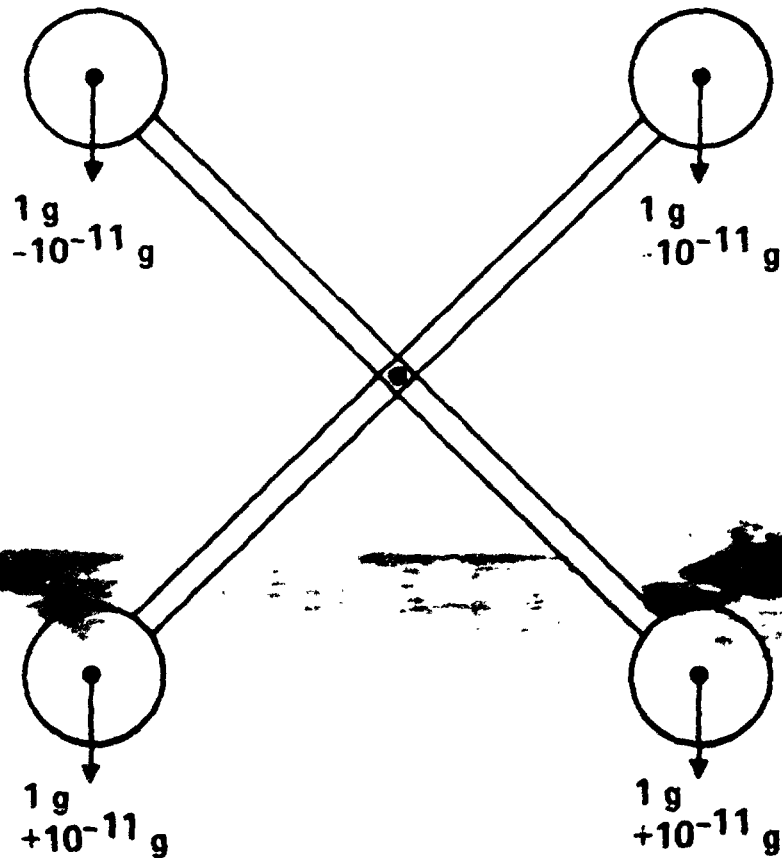

MECHANICAL METHODS OF  
CANCELLING  $1\text{ g}$  (+ OTHER)  
ACCELERATIONS USE  
SIMPLE, PASSIVE, INHERENTLY  
LINEAR FORCE DIFFERENTIAL  
MECHANISMS

ELECTRONIC METHODS OF  
CANCELLING  $1\text{ g}$  ACCELERATION  
REQUIRE COMPLICATED, ACTIVE  
DIFFERENTIAL CIRCUITS

ORDER OF PRECEDENCE

# GGG CHARACTERISTIC DIFFERENTIAL SELF REFERENCING



4808-3

GRADIENT TORQUE MEASURED  
BETWEEN SENSOR ARMS

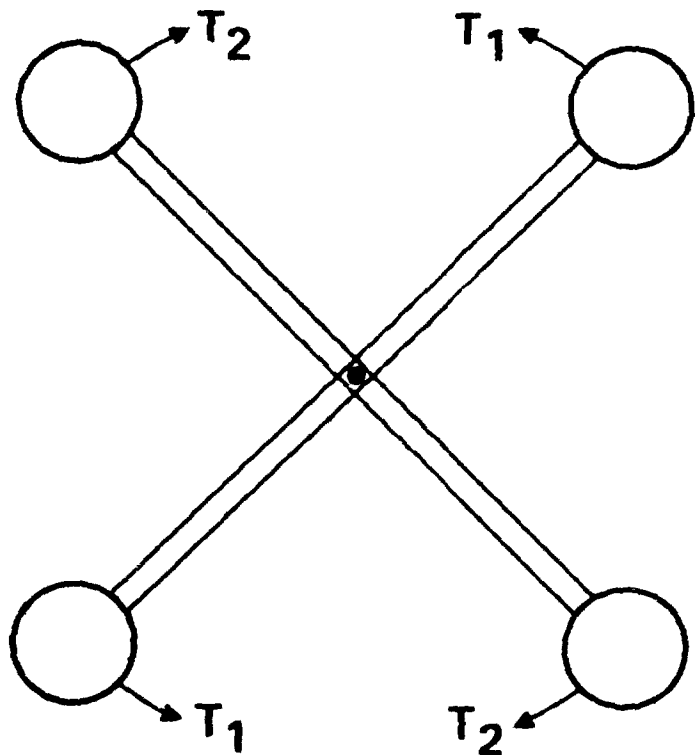

GRAVITY GRADIENT  
INDUCED TORQUE  
SENSED BY TWO FORCE  
DIFFERENTIAL SYSTEMS,  
THEN TORQUES ARE  
DIFFERENCED  
INTERNALLY (DOUBLY  
DIFFERENTIAL DESIGN)

SINGLY DIFFERENTIAL  
GRADIOMETERS CANNOT  
DISTINGUISH GRADIENT  
TORQUES FROM CASE  
TORQUES

ORIGINAL PAGE IS  
OF POOR QUALITY



# RGG CHARACTERISTIC ROTATIONAL MODULATION OF SIGNAL



4806-2

GRADIENT TORQUE MODULATED  
AT TWICE ROTATION FREQUENCY

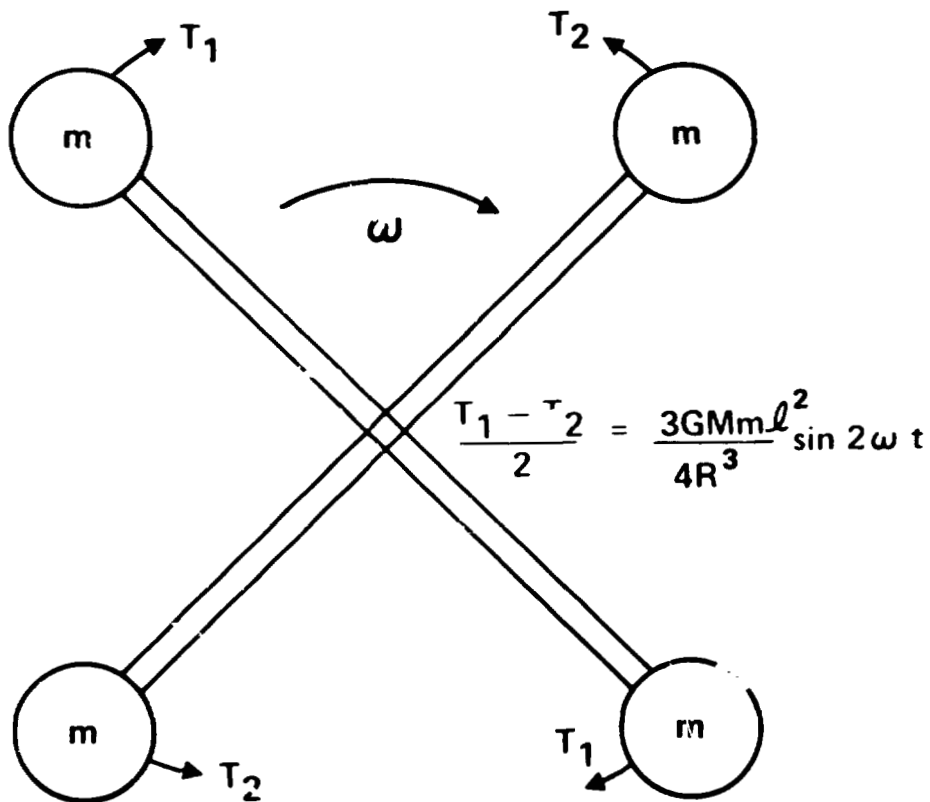

GRAVITY GRADIENT  
SIGNAL TAGGED WITH  
 $2\omega$  MODULATION  
ALLOWING SEPARATION  
FROM MOST ERROR AND  
NOISE SOURCES

NON-ROTATED DESIGNS  
REQUIRE ORDERS OF  
MAGNITUDE BETTER  
FABRICATION ACCURACY  
AND ERROR CONTROL

ORIGINAL PAGE IS  
OF POOR QUALITY

# RGG CHARACTERISTIC MECHANICAL RESONATOR PREAMPLIFIER



3874-11 R1

SENSOR DESIGNED AS  
TORSIONALLY RESONANT  
STRUCTURE AT  $2\omega$

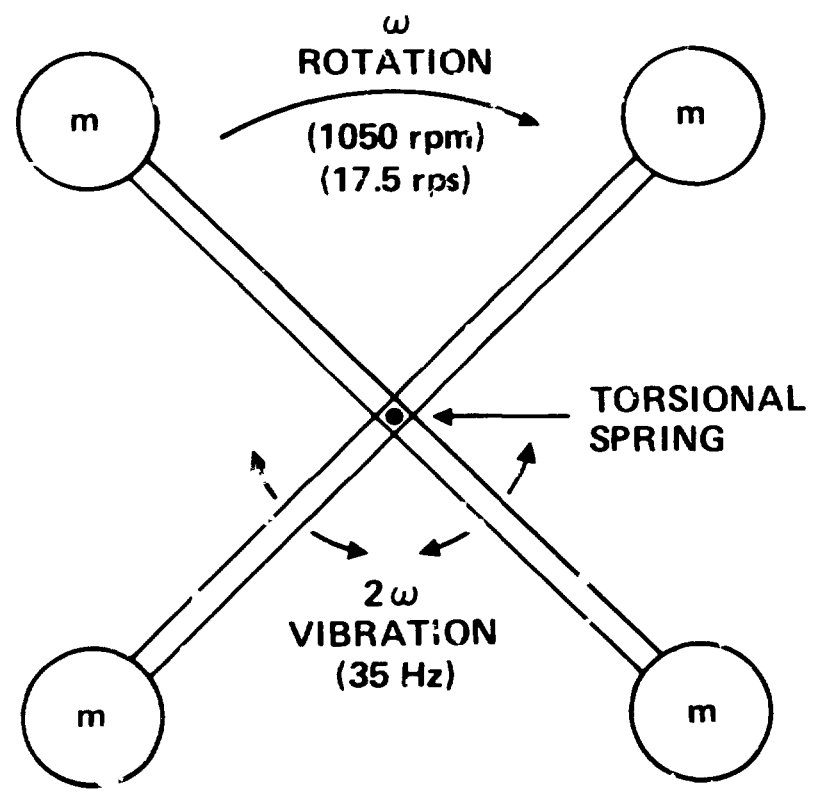

STIFF TORSIONAL SPRING  
RESULTS IN RUGGED  
MECHANICAL DESIGN

MECHANICAL RESONANCE  
PROVIDES LOW NOISE  
PREAMPLIFICATION AND  
REJECTION OF OFF-RESONANT  
SIGNALS PRIOR TO DETECTION  
BY TRANSDUCER AND  
ELECTRONICS

NON-RESONANT DESIGNING  
REQUIRE FABRICATION AND  
MAINTENANCE OF EXTREMELY  
LINEAR LOW NOISE PICKOFFS  
AND ELECTRONICS

CONCEPT UNIQUE TO RGG

ORIGINAL PAGE IS  
OF POOR QUALITY

# ROTATING GRAVITY GRADIOMETER (RGG) MODE OF OPERATION

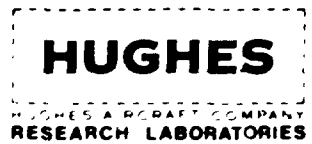

4840-22

GRAVITY GRADIENT OF MASS ANOMALY M AT DISTANCE R

$$\Gamma_{XY} = \frac{GM}{R^3}$$

CAUSES DIFFERENTIAL TORQUE AT TWICE ROTATION FREQUENCY

$$\frac{T_1 - T_2}{2} = \frac{3 GM m \ell^2}{4R^3} \sin 2\omega t$$

TYPICAL GRAVITY GRADIENT COMPONENT

MOON	1000 EOTVOS
MAN	200 EOTVOS
MASCONS	1 TO 50 EOTVOS

(1 EOTVOS = 0.1 mgal/km  $\approx 10^{-12}$  g's/cm)

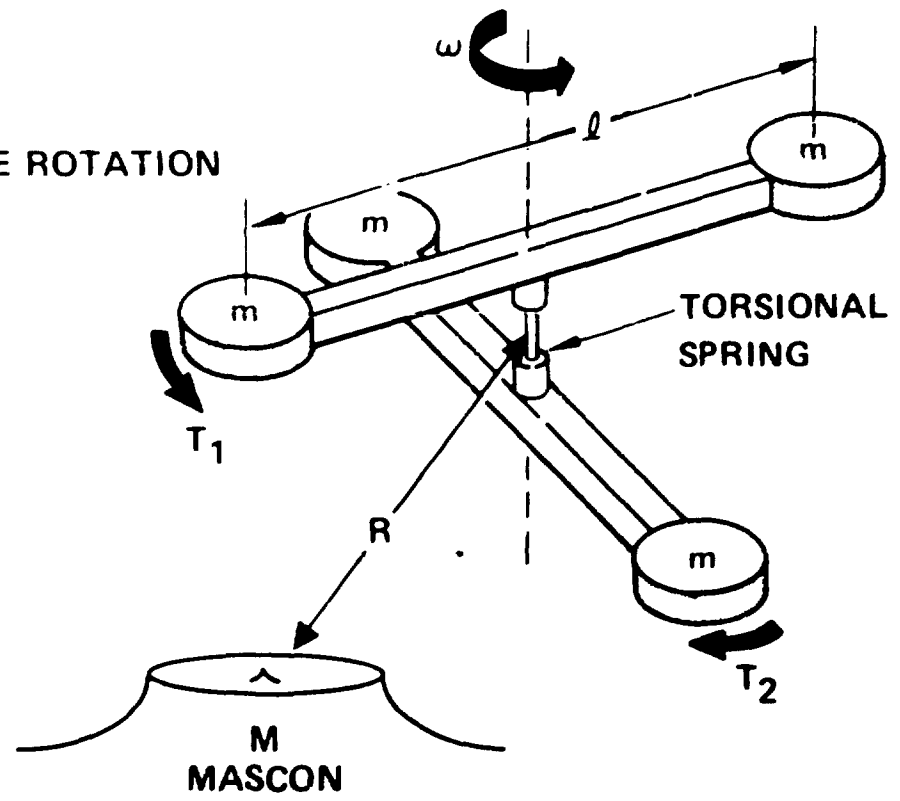

ORIGINAL IMAGE IS OF POOR QUALITY

# ROTATING GRAVITY GRADIOMETER "FEASIBILITY" MODEL

HUGHES

RESEARCH LABORATORIES

DESIGNED 1968-1969

4940-1



- PLASTIC COMPONENTS
- SELF-CONTAINED AMPLIFIER/TRANSMITTER
- NO TEMPERATURE CONTROL
- NO PRECISE BALANCE
- SOFT SPIN BEARING
- VERTICAL SPIN AXIS ONLY
- 1 EU AT 10 sec DESIGN

ORIGINATOR'S  
OF POOR QUALITY

# ROTATING GRAVITY GRADIOMETER LUNAR ORBITER LAB SIMULATION

**HUGHES**

RESEARCH LABORATORIES

4840-3

M-239

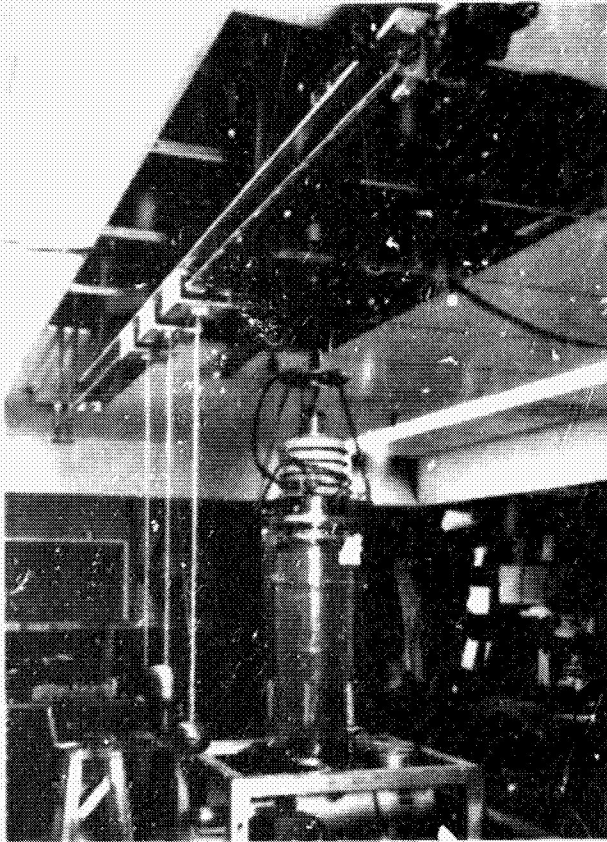

MEASURED SMALL  
SIGNAL DIFFERENCE  
BETWEEN TWO  
CLOSELY SPACED  
GRAVITY GRADIENT  
SIGNALS

25 EOTVOS MAGNITUDE

2 EOTVOS DIFFERENCE

25 sec TIME SEPARATION

MASS DISTANCE - 2 ft  
FIRST MASS - 14 kg  
SECOND MASS - 15 kg

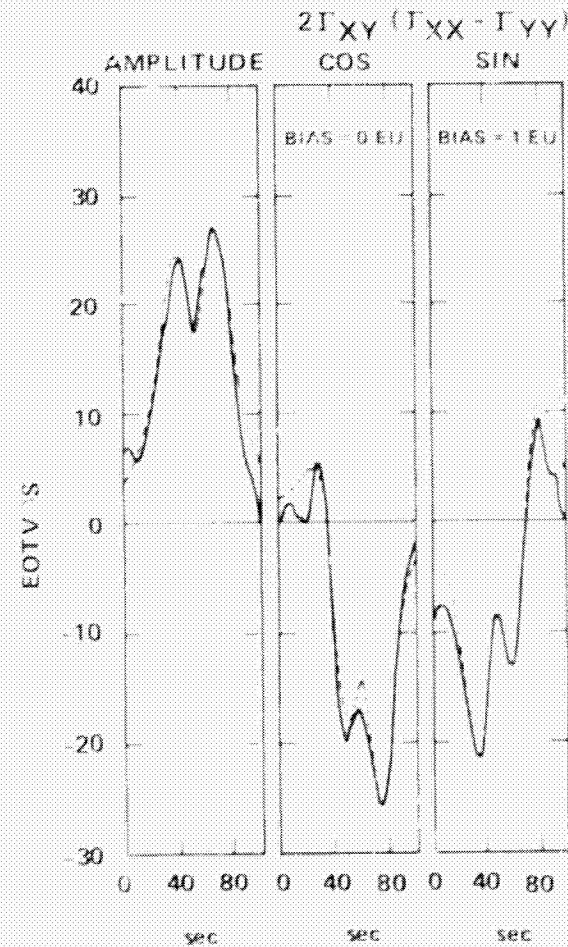



# PROTOTYPE SPINNING APOLLO SUBSATELLITE ROTATING GRAVITY GRADIOMETER

**HUGHES**  
HUGHES AIRCRAFT COMPANY  
RESEARCH LABORATORIES

4840-2

M7447

M7446

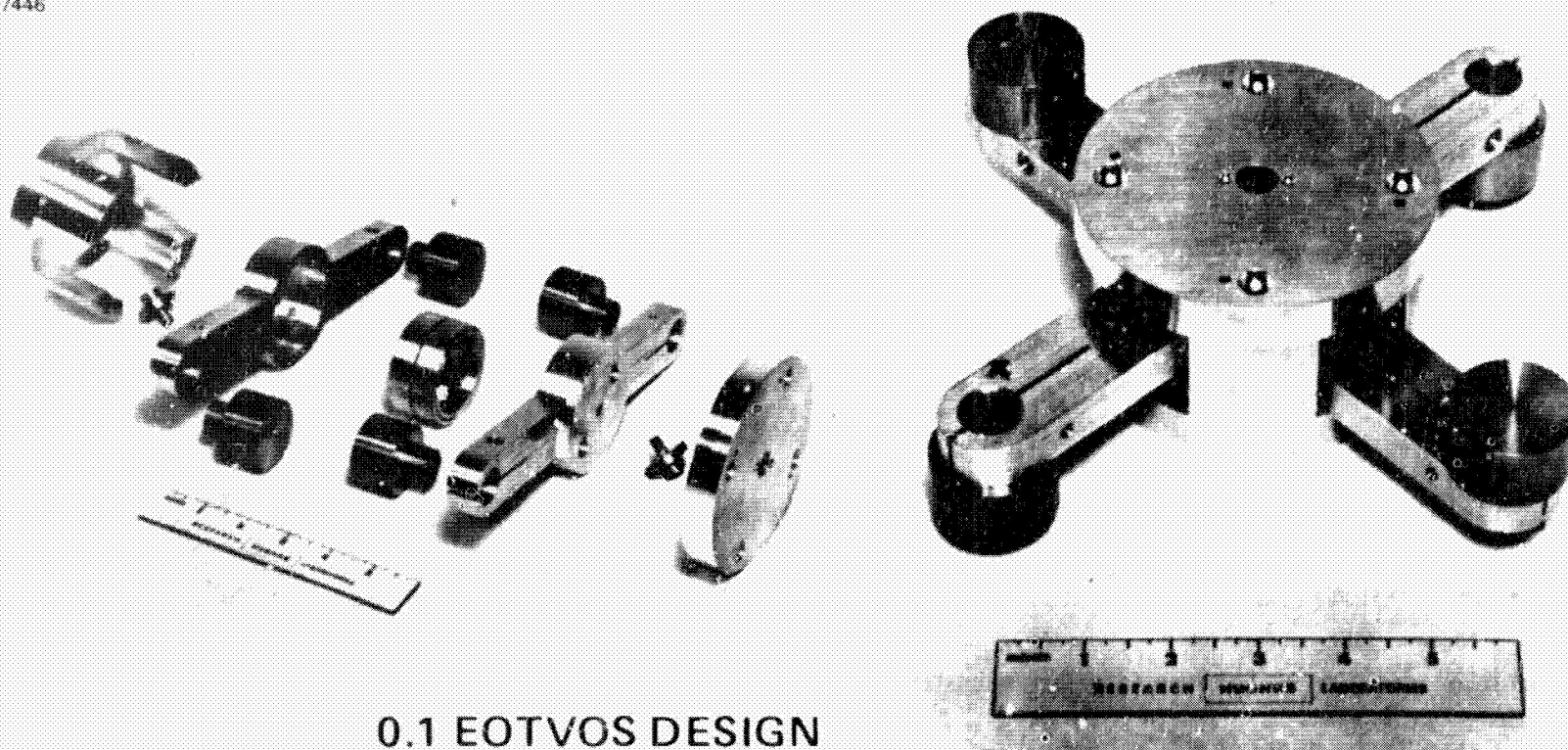

ORIENTED  
OF POOR QUALITY

0.1 EOTVOS DESIGN  
30 cm diam

**HUGHES**  
HUGHES AIRCRAFT COMPANY  
RESEARCH LABORATORIES

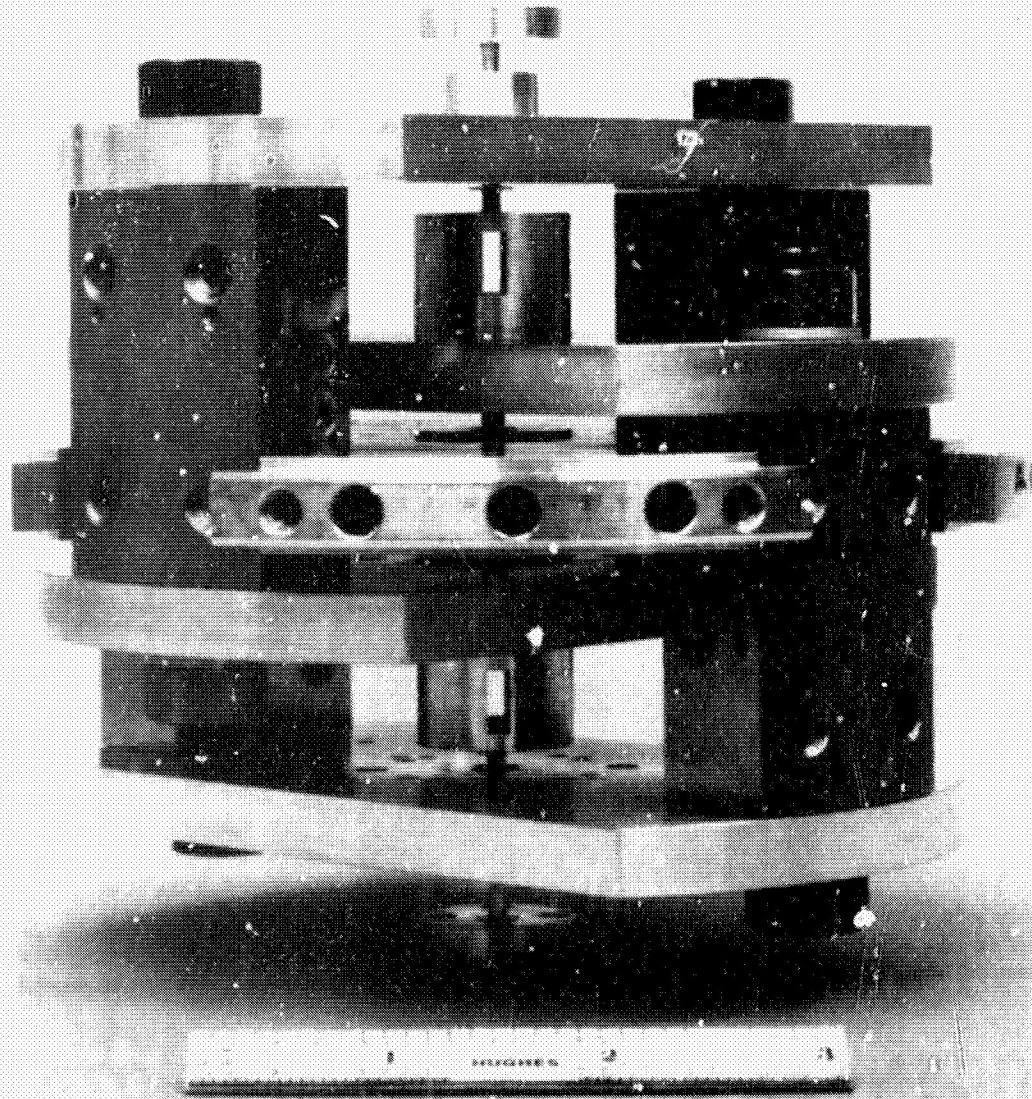

**PGG-2  
SENSING  
STRUCTURE**

ORDERING PARTS  
OF POOR QUALITY

# PIEZOELECTRIC BENDER TRANSDUCER

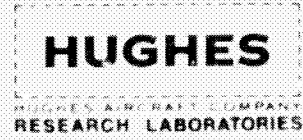

M9910

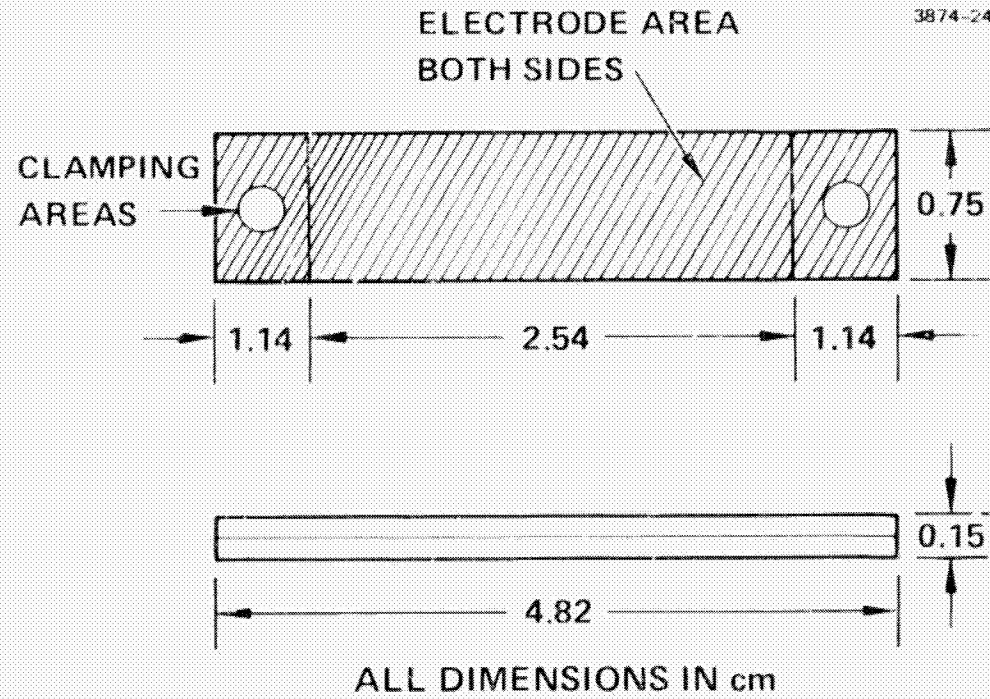
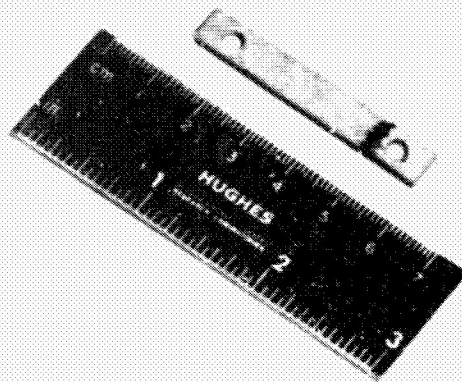



# SENSING STRUCTURE WITH PIEZOELECTRICS MOUNTED

**HUGHES**  
HUGHES AIRCRAFT COMPANY  
RESEARCH LABORATORIES

74-32003

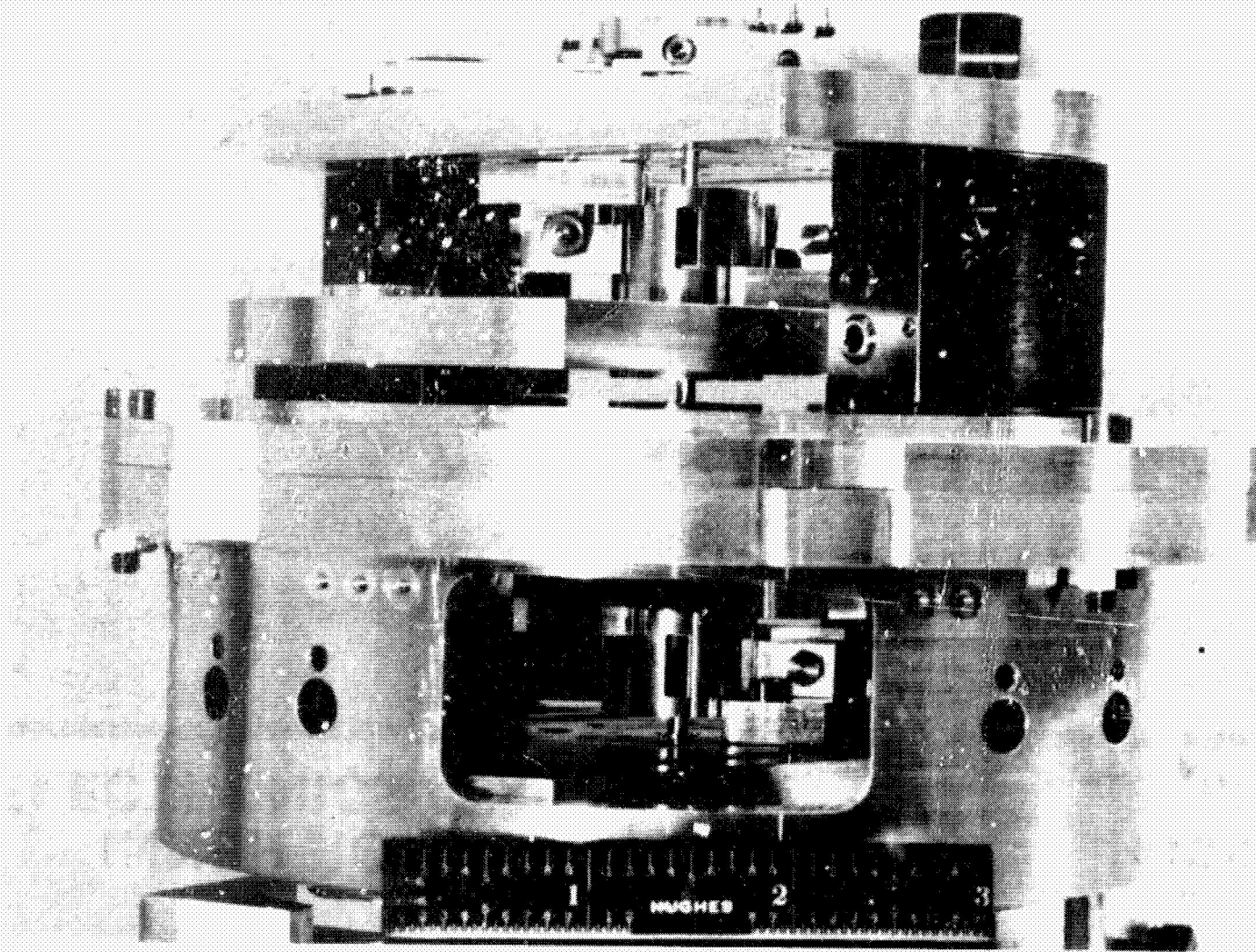

ORIGINAL OF PHOTOGRAPH

# INNER ROTOR AND ELECTRONICS ASSEMBLED

**HUGHES**

HUGHES AIRCRAFT COMPANY  
RESEARCH LABORATORIES

76-51187

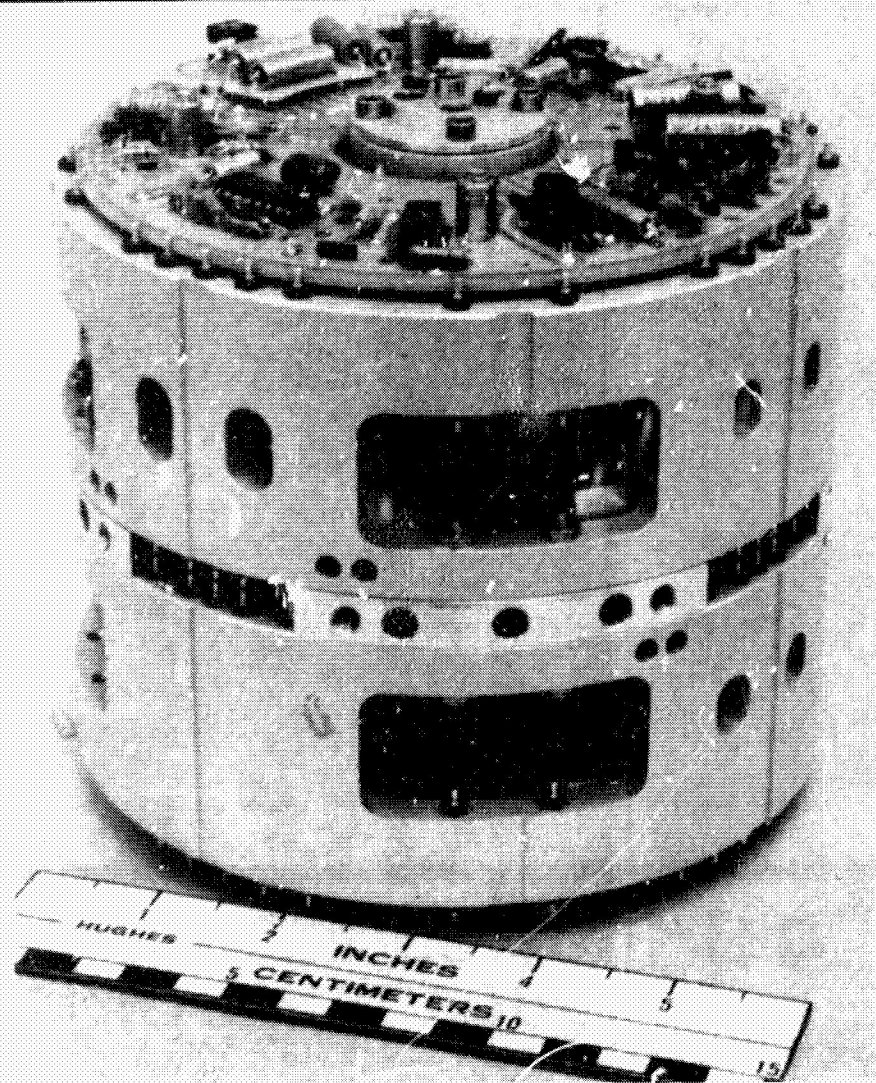

OF POINT QUALITY

76-51190

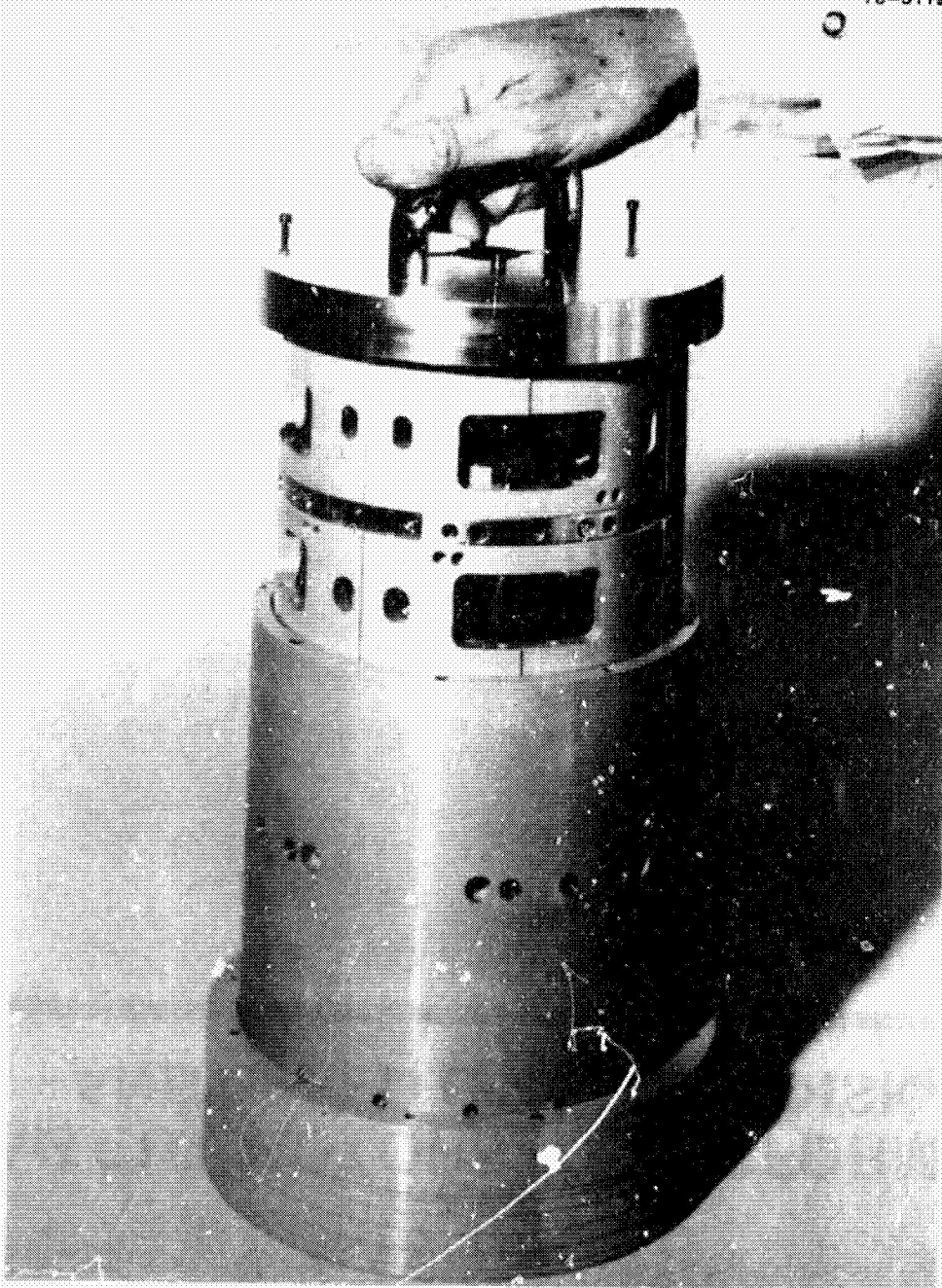

**HUGHES**  
HUGHES AIRCRAFT COMPANY  
RESEARCH LABORATORIES

## INSERTING INNER ROTOR INTO OUTER ROTOR

OFFICE OF  
RESEARCH  
OF POOR QUALITY

# DRAG CUP MOTORS, TRANSFORMERS, AND SPEED CONTROL DISK

**HUGHES**  
HUGHES AIRCRAFT COMPANY  
RESEARCH LABORATORIES

76-61188

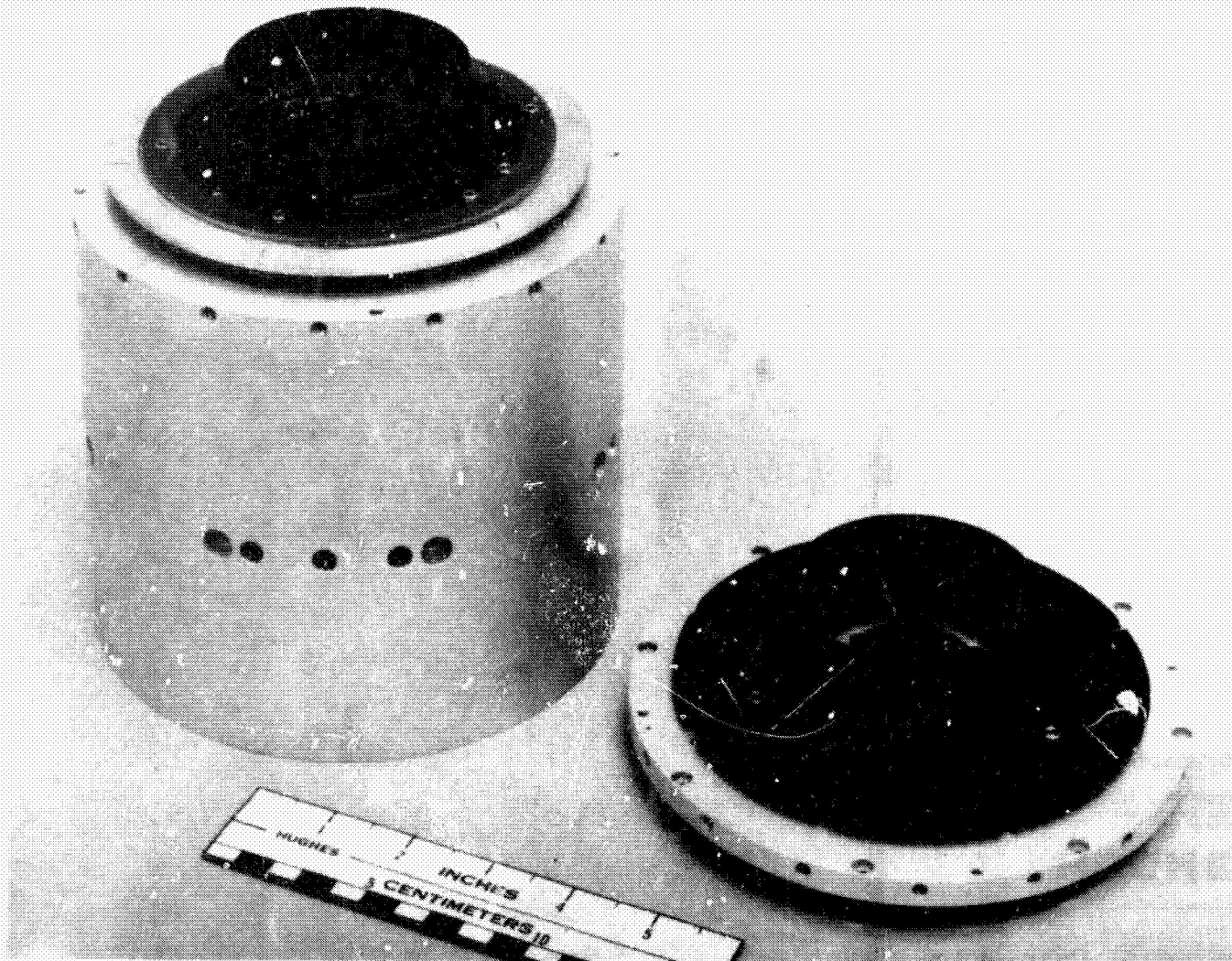



# ASSEMBLED RGG

**HUGHES**

HUGHES AIRCRAFT COMPANY  
RESEARCH LABORATORIES

77-53528

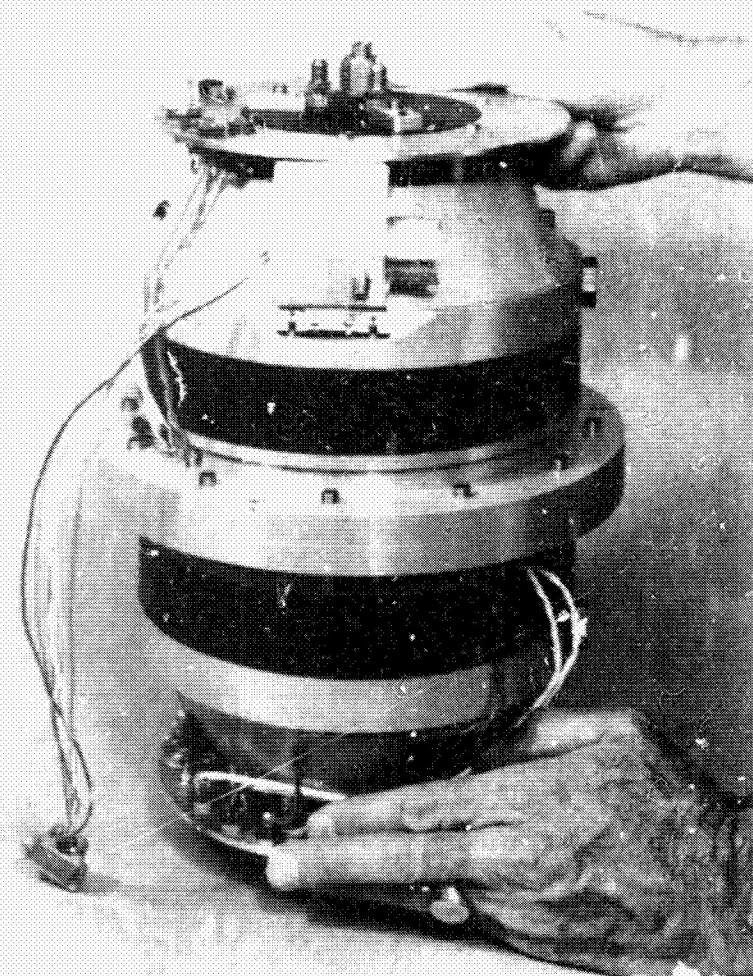

## SIZE

12 INCH x 7.5 INCH DIAMETER  
(30 x 20 cm)

## WEIGHT

39 LB. (18 kg)

## RESONANT FREQUENCY ( $2\omega$ )

34.729 Hz

## SPIN SPEED ( $\omega$ )

1041.84 rpm (17.364 Hz)

Q = 300

ORIGINAL COPY  
OF PDR 000007

# SPEED CONTROL ELECTRONICS

**HUGHES**  
HUGHES AIRCRAFT COMPANY  
RESEARCH LABORATORIES

4840-33

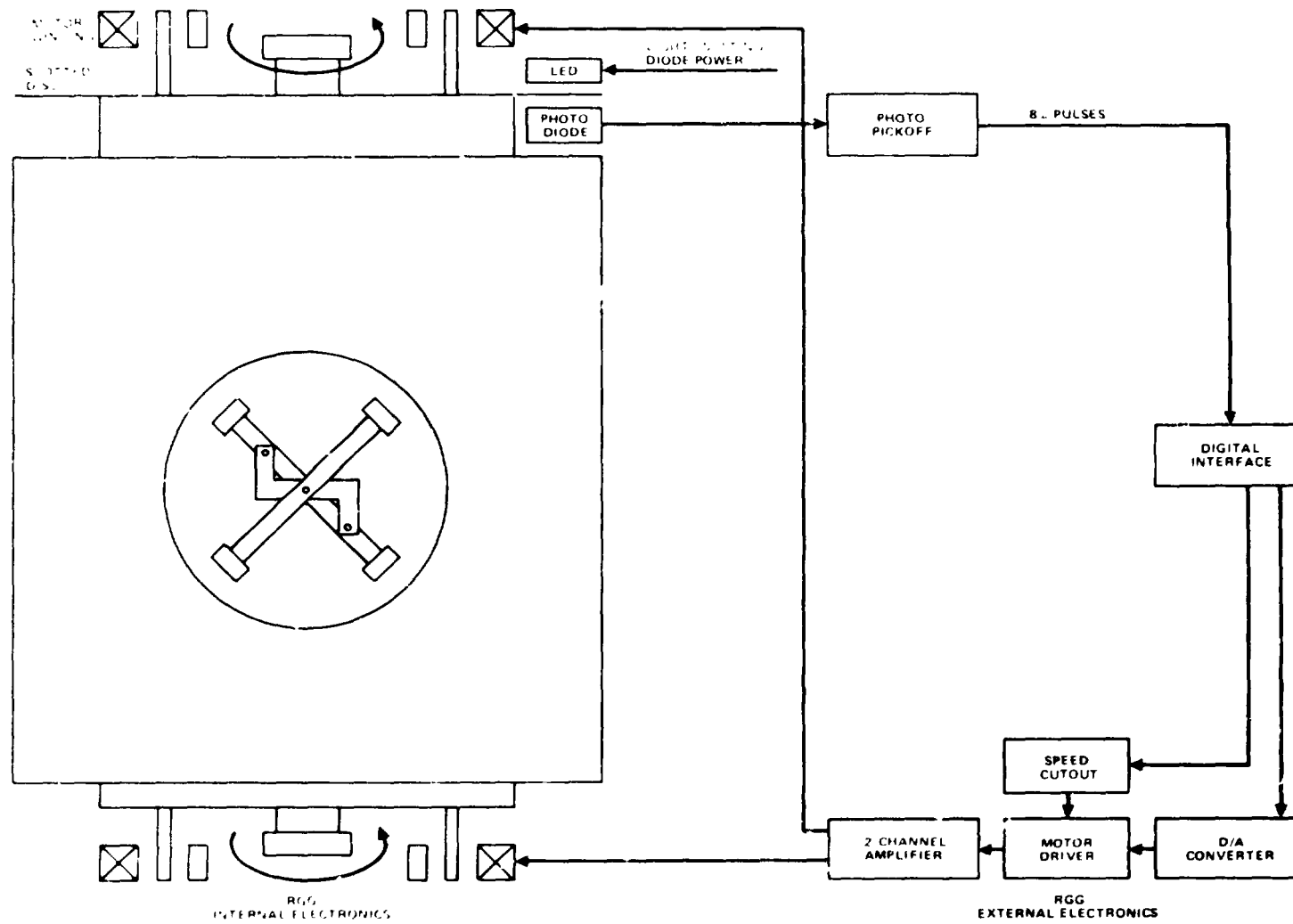

OFFICE OF  
OF POOR QUALITY

# DATA OUTPUT ELECTRONICS



4840-32

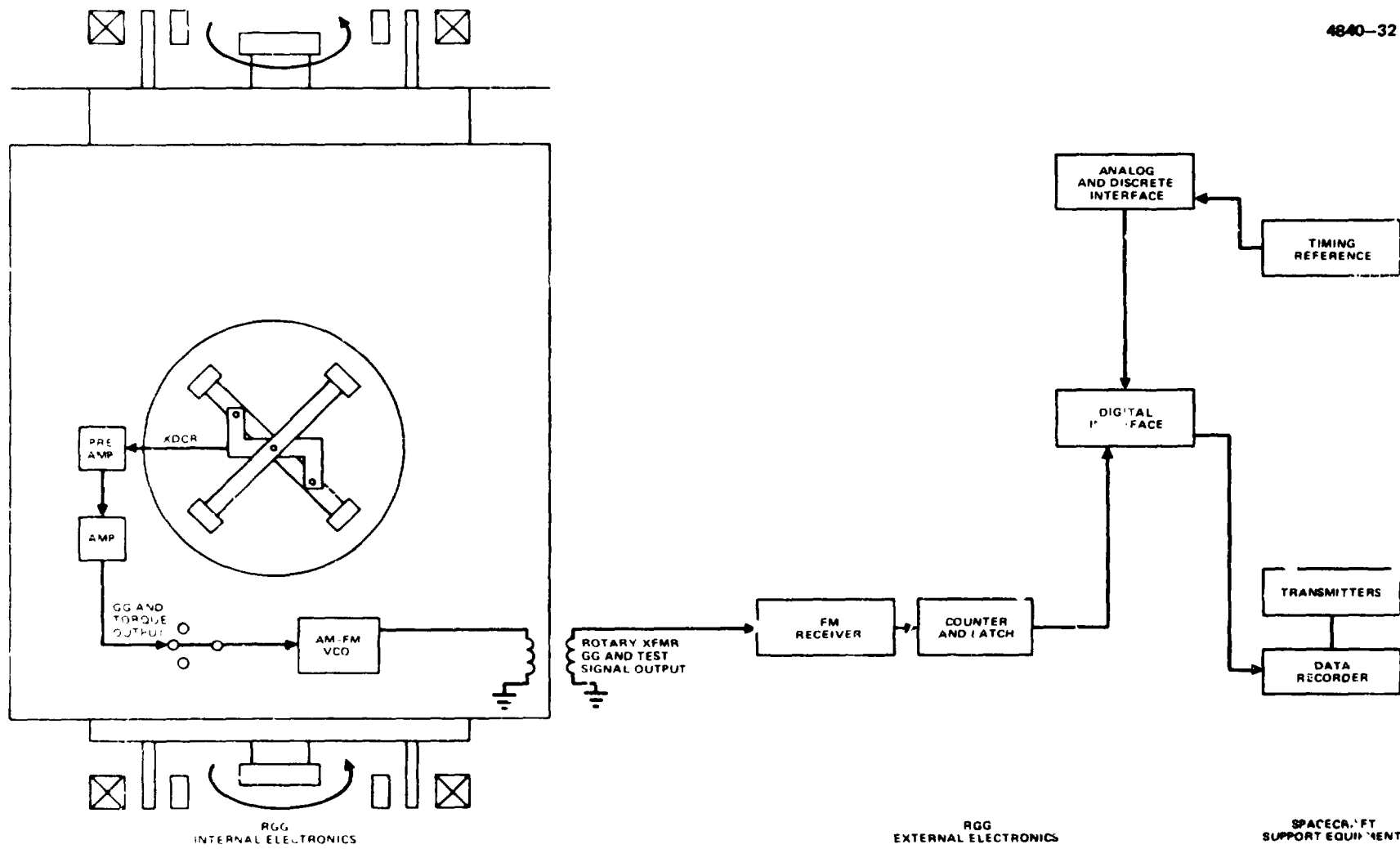

ORIGINATOR'S COPY OF POOR QUALITY

# THERMAL CONTROL AND P.S. ELECTRONICS

**HUGHES**  
HUGHES AIRCRAFT COMPANY  
RESEARCH LABORATORIES

4840-34

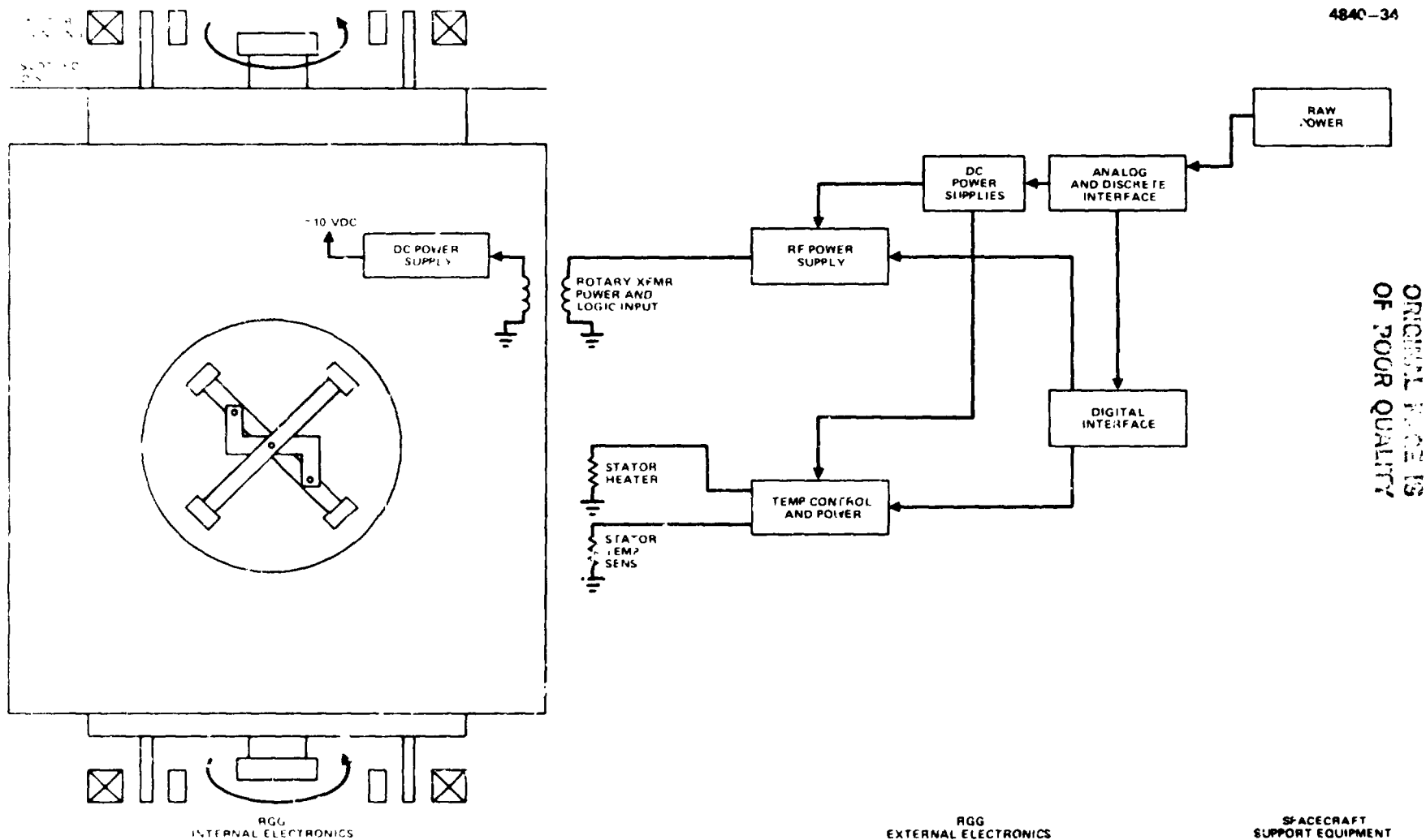



# TEST AND CONTROL ELECTRONICS

**HUGHES**

HUGHES AEROSPACE COMPANY  
RESEARCH LABORATORIES

4840-31

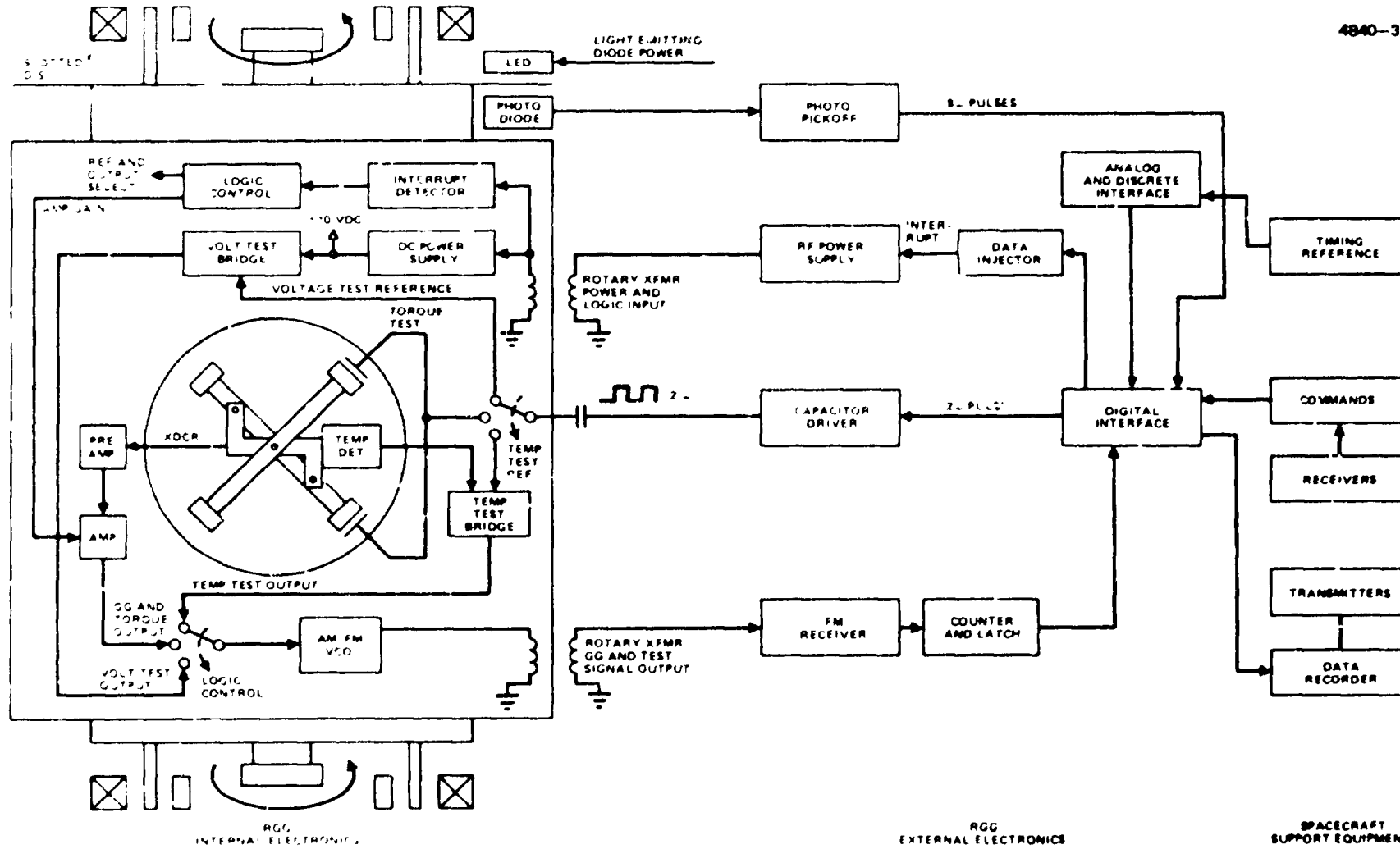

ORIGINALLY DESIGNED  
OF POOR QUALITY

# LUNAR RGG ELECTRONICS

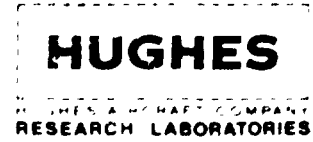

4840-30

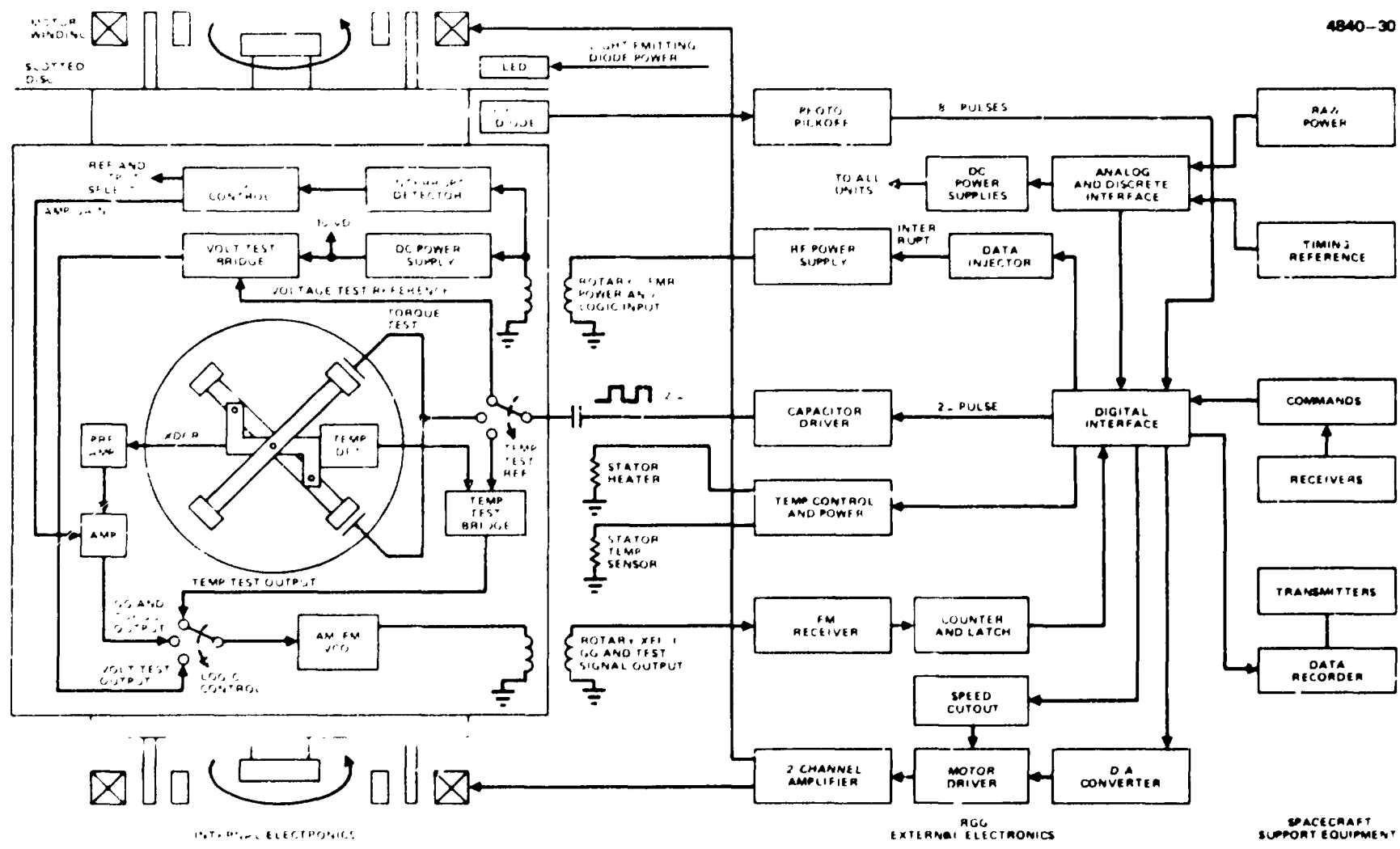

CROSS SECTION OF POWER CABLE

# GRAVITY GRADIENT INDUCER

**HUGHES**

HUGHES AIRCRAFT COMPANY  
RESEARCH LABORATORIES

78-64245

- PURPOSE:

TO MEASURE RGG SCALE  
FACTOR AND LINEARITY

- 5.177-IN. SPHERES

- MATERIALS:

- ALUMINUM
- TITANIUM
- BRASS



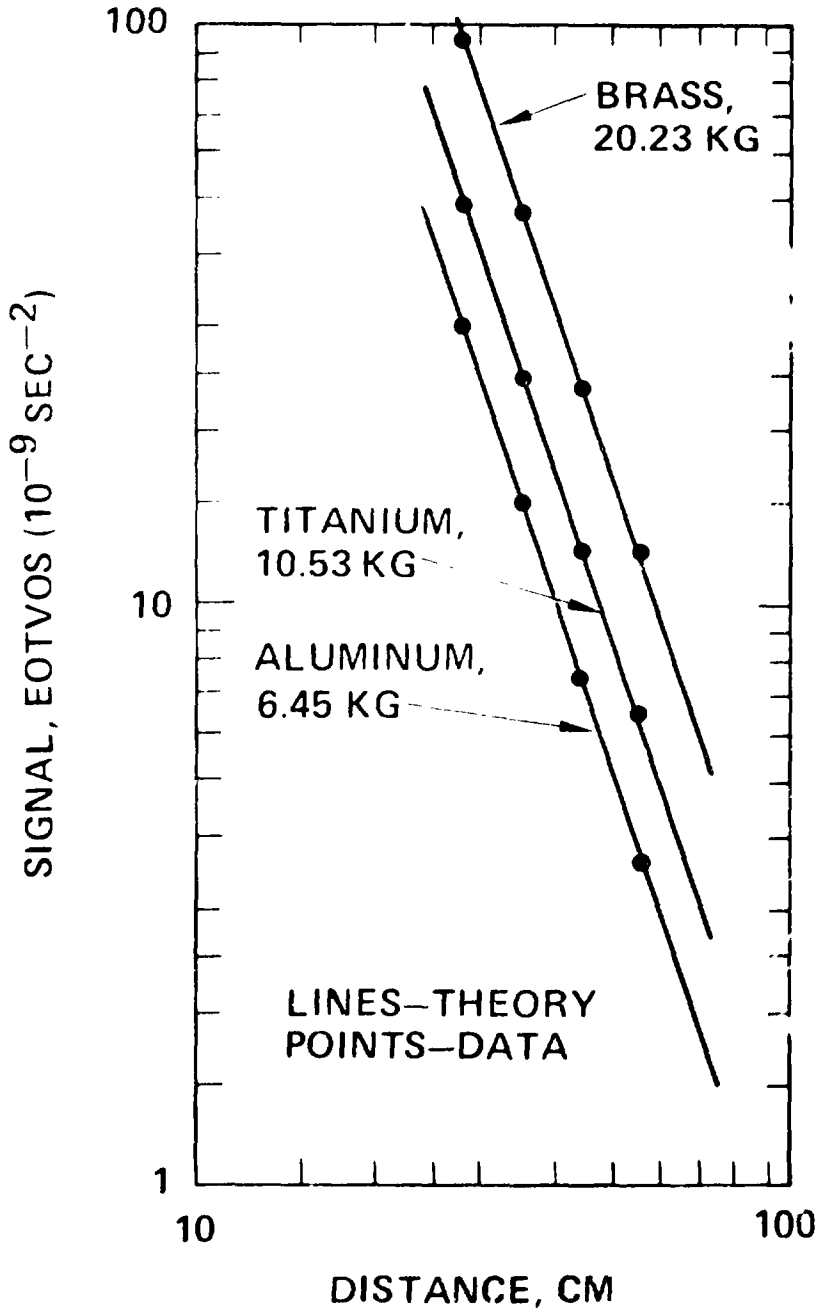

**HUGHES**  
A DIVISION OF THE LOCKHEED MARTIN COMPANY  
RESEARCH LABORATORIES

# GRAVITY GRADIENTS INDUCED BY TEST MASS SPHERES

ORIGINAL PRODUCTS  
OF POOR QUALITY

# ROTATING GRAVITY GRADIOMETER SENSING 35 KG MASS



10383-10

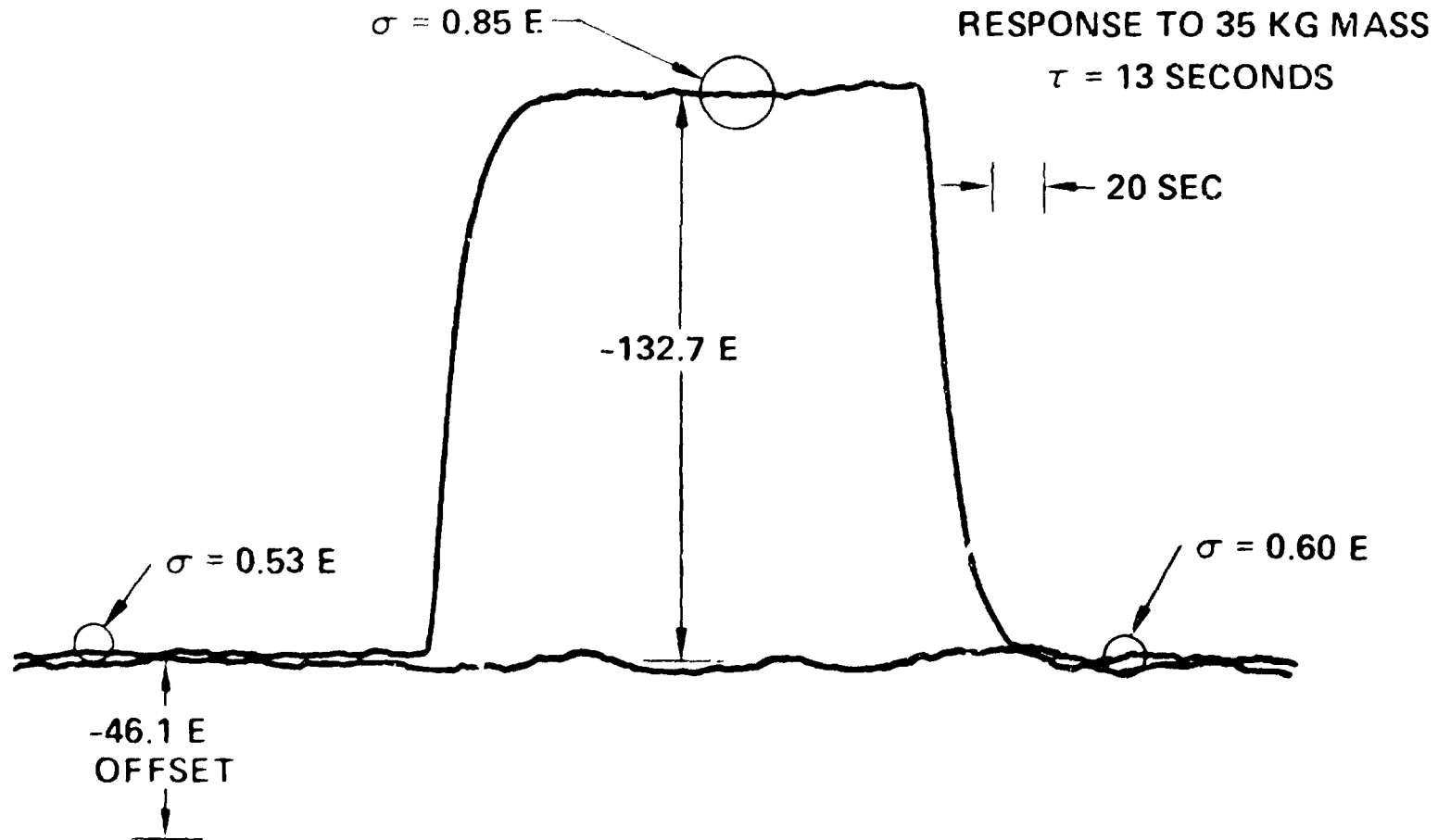

OFFICE OF  
PRODUCTION

NOVEMBER 1980

# LUNAR GRAVITY GRADIOMETER SYSTEM



4840-28 R1

- LOCATION – ANYWHERE WITHIN THE SPACECRAFT
- WEIGHT – RGG: 16 kg EACH  
ELECTRONICS: 3 kg PER RGG
- VOLUME – RGG: 44 cm LONG x 35 cm diam =  $42,000 \text{ cm}^3 = 0.04 \text{ m}^3$   
ELECTRONICS: 37 cm x 15 cm x 8 cm =  $4440 \text{ cm}^3 = 0.004 \text{ m}^3$
- POWER – MOTORS: 11 W  
ELECTRONICS: 7 W  
HEATERS: APPROX 10 W (DEPENDS ON! OPERATING TEMP RANGE)
- THERMAL – WILL OPERATE WITHIN SPEC:  $0^\circ\text{C}$  TO  $55^\circ\text{C}$   
(HEATER POWER CAN BE REDUCED IF TEMPERATURE RANGE IS REDUCED)  
WILL SURVIVE WITHOUT DEGRADATION:  $-20^\circ\text{C}$  TO  $75^\circ\text{C}$

ORIGINAL PARTS  
OF POOR QUALITY

# ROTATING GRAVITY GRADIOMETER OUTLINE AND MOUNTING



4840-35

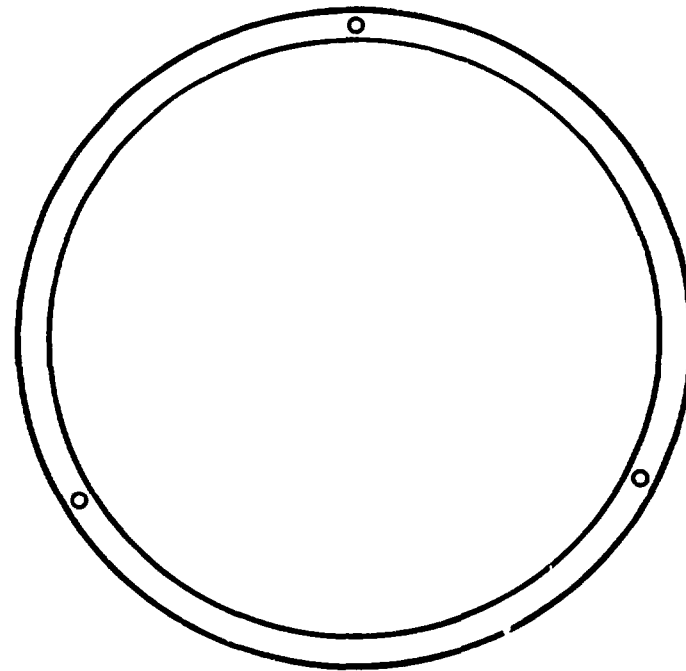
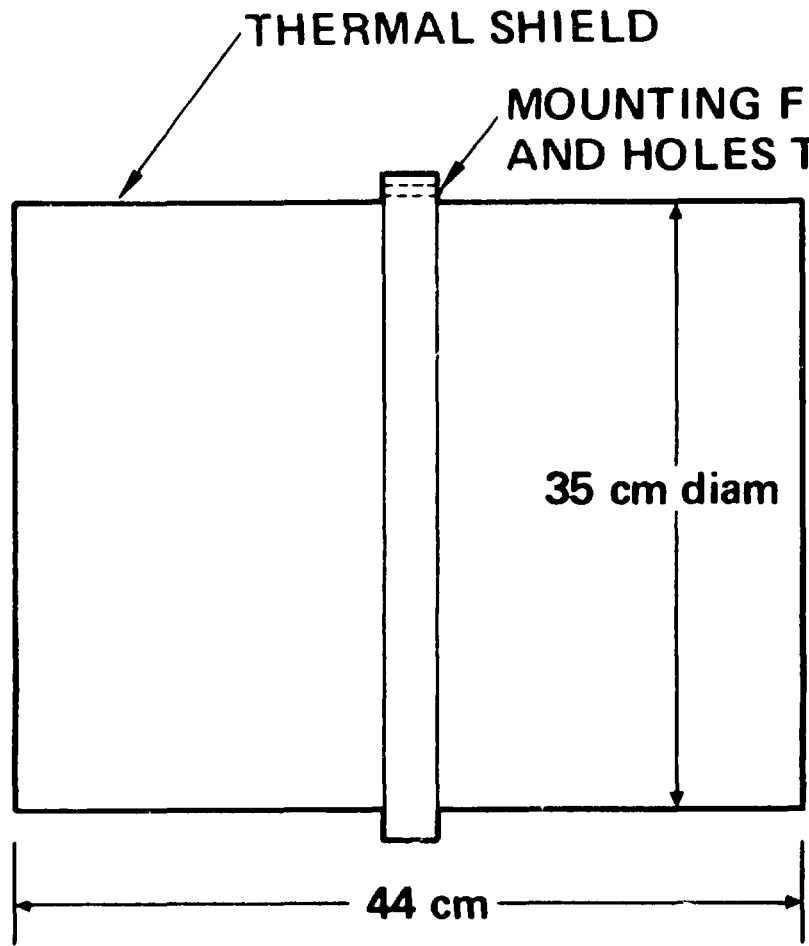

ORIGINAL DESIGN  
OF POOR QUALITY

# RGG ELECTRONICS OUTLINE AND MOUNTING

**HUGHES**  
HUGHES AIRCRAFT COMPANY  
RESEARCH LABORATORIES

4840-36

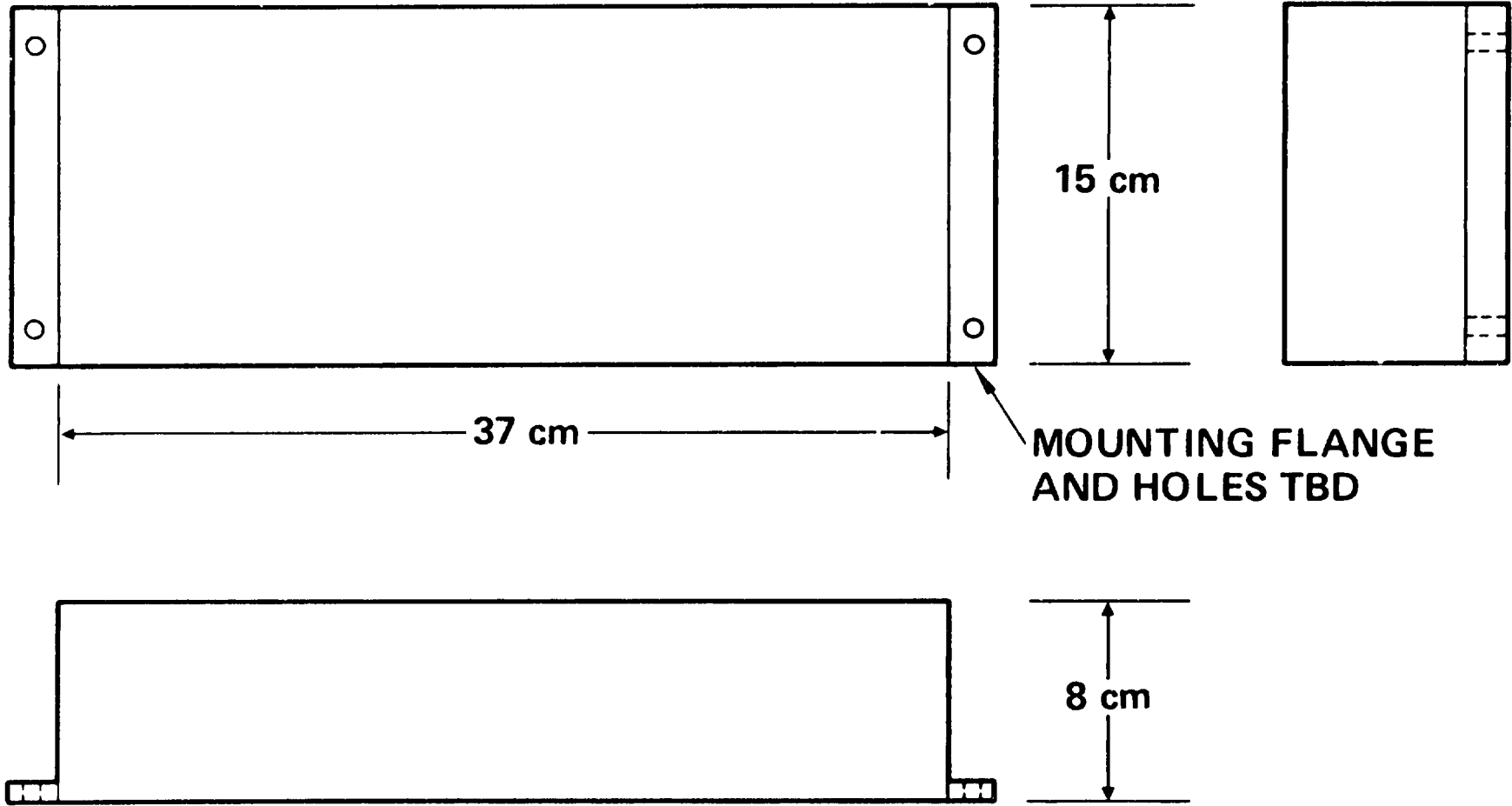

Characteristics of  
OF POOR QUALITY



# DIGITAL INTERFACE REGISTERS



4840-25

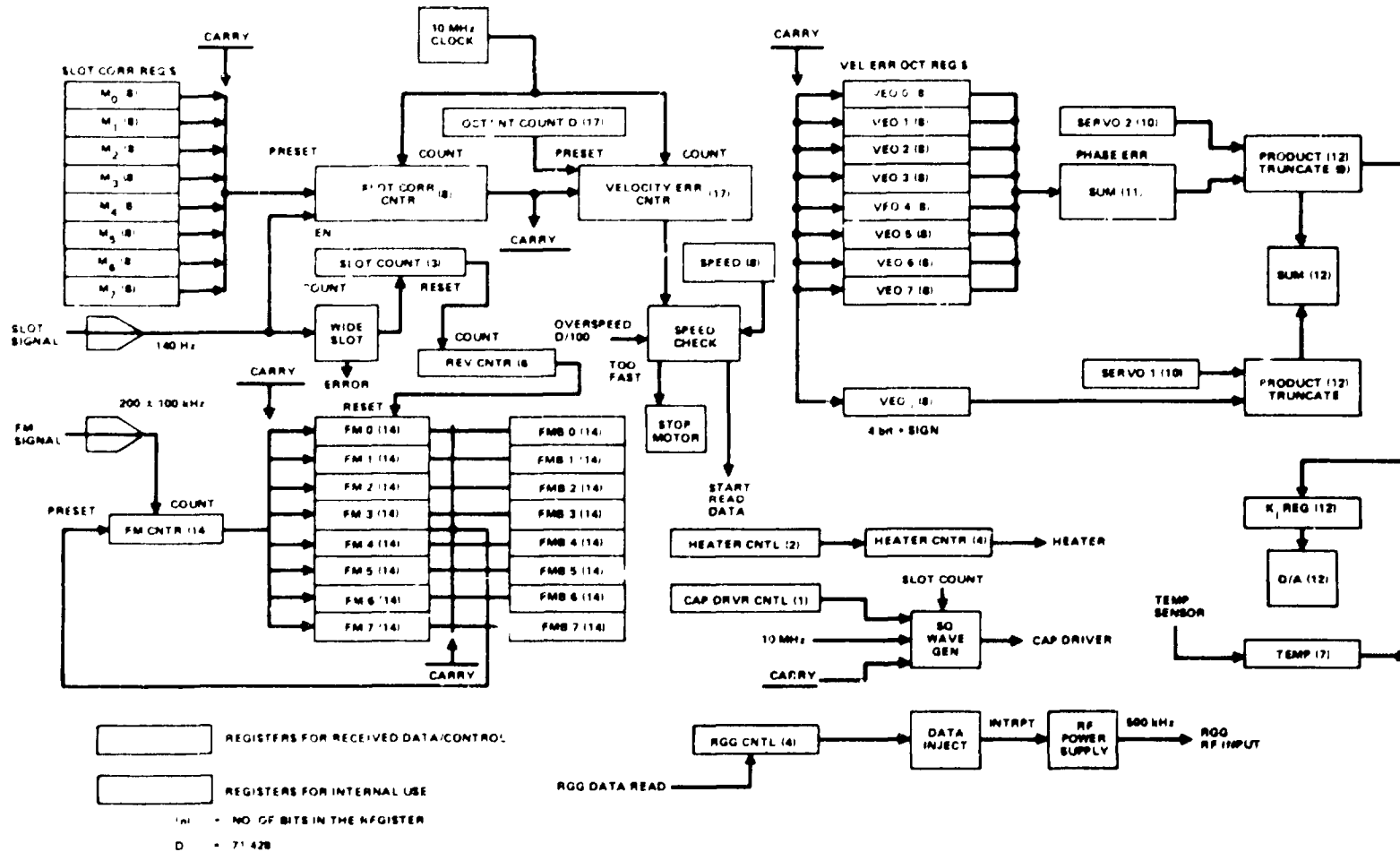

OF PCOR

# RGG OUTPUT DATA

**HUGHES**

HUGHES AIRCRAFT COMPANY  
RESEARCH LABORATORIES

4840-27

- GRAVITY GRADIENT DATA – NORMAL OUTPUT
  - 1) NORMAL AMPLIFIER GAIN
  - 2) LOW AMPLIFIER GAIN
  
- ENGINEERING DATA – TWICE PER ORBIT (NEAR POLES) OR ON COMMAND
  - 1) INTERNAL ELECTRONICS REGULATED DC VOLTAGE
  - 2) ROTOR TEMPERATURE
  - 3) CALIBRATION TEST OUTPUT (COMBINED WITH GRAVITY GRADIENT DATA)
  
- DATA RATE – LESS THAN 100 bits PER sec

QUALITY  
OF WORK  
QUALITY

# RGG SPEED CONTROL FLOW CHART



4840-23

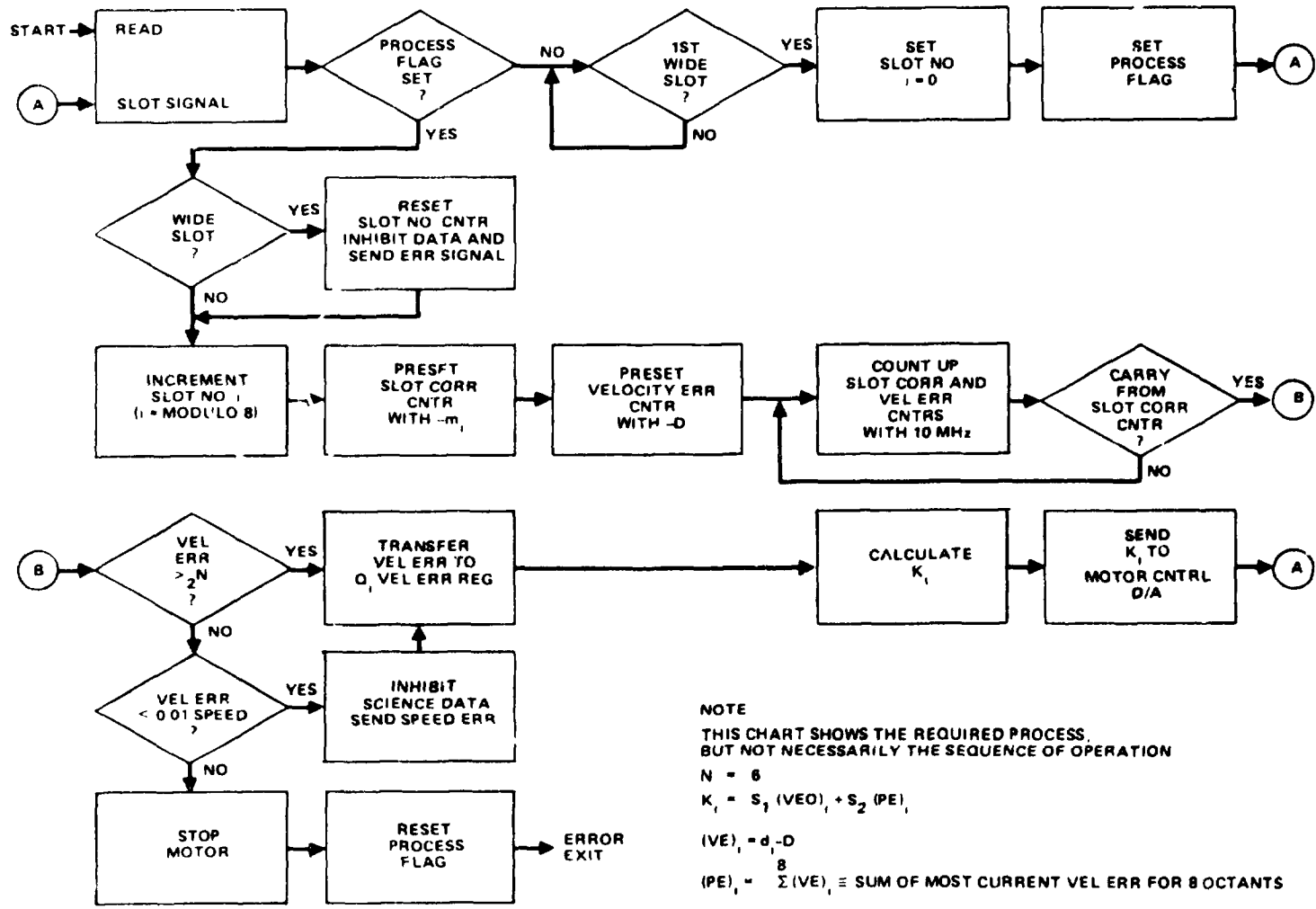

NOTE  
 THIS CHART SHOWS THE REQUIRED PROCESS,  
 BUT NOT NECESSARILY THE SEQUENCE OF OPERATION  
 $N = 8$   
 $K_i = S_1 (VEO)_i + S_2 (PE)_i$   
 $(VE)_i = d_i - D$   
 $(PE)_i = \sum_{j=1}^8 (VE)_j \equiv$  SUM OF MOST CURRENT VEL ERR FOR 8 OCTANTS

OF PCCA COMPANY

# RGG SPEED CONTROL TIMING

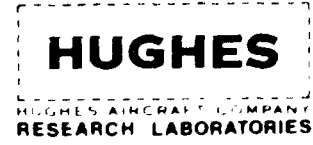

4840-24

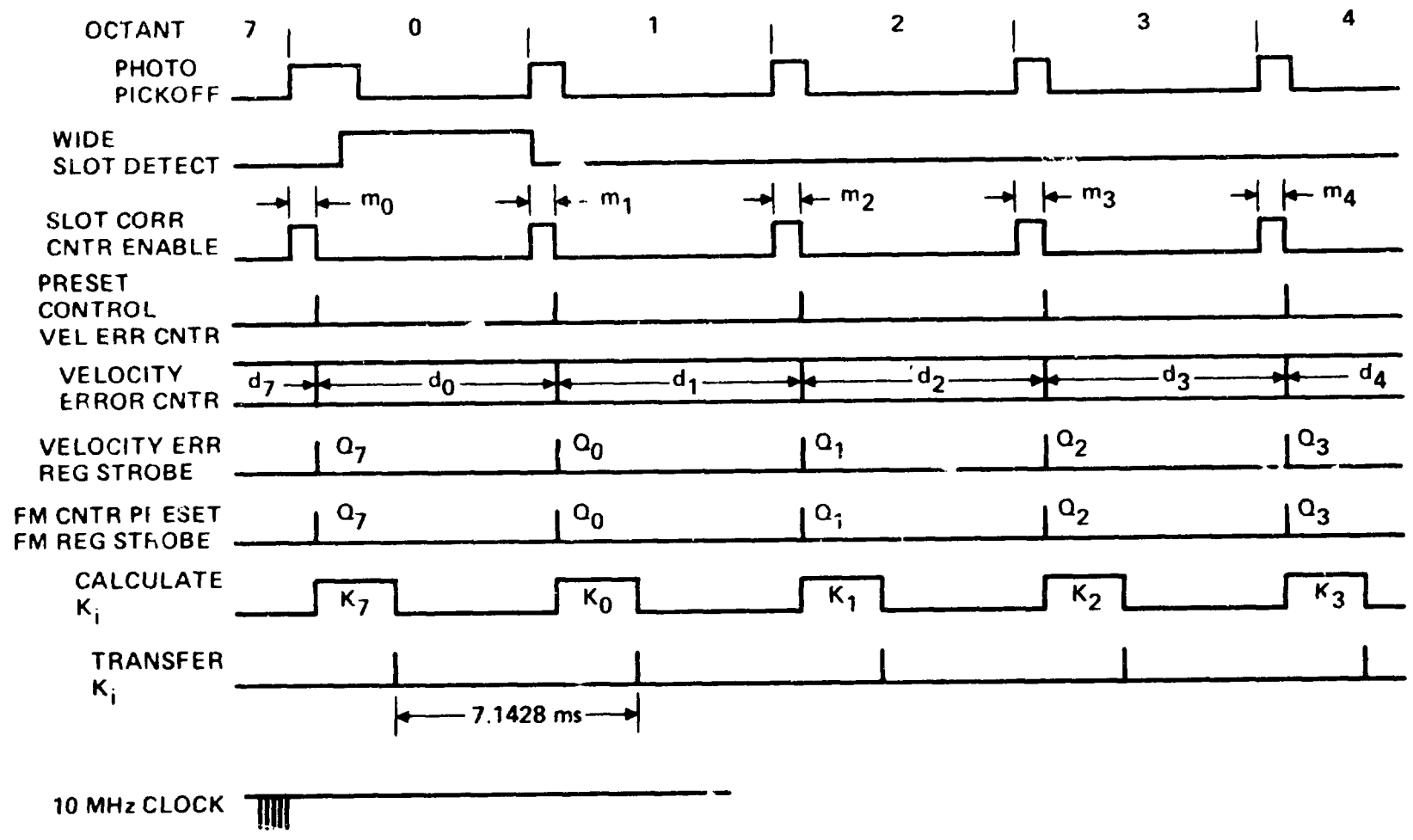

ON THE QUALITY OF POOR QUALITY

# LUNAR RGG SYSTEM COMMAND DATA

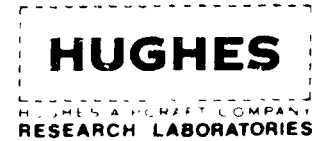

4840-26

- 16 LOGIC STATES IN RGG (I.E., 500 kHz INTERRUPT COMMANDS) – 4 bits
- MOTOR STOP CONTROL – 1 bit
- TEMPERATURE CONTROL (INCR/DECR) – 2 bits
- DATA READ CONTROL – 2 bits
- CAPACITOR DRIVER CONTROL – 1 bit
- MOTOR DRIVE SERVO VELOCITY GAIN – 10 bits
- MOTOR DRIVE SERVO PHASE GAIN – 10 bits

OF 1 002 QUANTITY

# EXTERNAL ELECTRONICS ENGINEERING DATA



4840-22

- VELOCITY ERROR FOR EACH OF 8 OCTANTS –  
4 bits + SIGN (40 bits TOTAL)
- WIDE SLOT MARKER – 1 bit
- MOTOR DRIVE – EIGHT 12-bit WORDS IN SEQUENCE
- MODE CONTROL – 4 bits
- MOTOR STOP CONTROL – 1 bit
- MOTOR SPEED ERROR – 1 bit
- DATA RATE -- LESS THAN 150 bits PER min

ORIGINAL PROPERTY  
OF POOR COMPANY