

## **General Disclaimer**

### **One or more of the Following Statements may affect this Document**

- This document has been reproduced from the best copy furnished by the organizational source. It is being released in the interest of making available as much information as possible.
- This document may contain data, which exceeds the sheet parameters. It was furnished in this condition by the organizational source and is the best copy available.
- This document may contain tone-on-tone or color graphs, charts and/or pictures, which have been reproduced in black and white.
- This document is paginated as submitted by the original source.
- Portions of this document are not fully legible due to the historical nature of some of the material. However, it is the best reproduction available from the original submission.

**Bolt Beranek and Newman Inc.**



**NASA CR-170451**

**BBN Report 4748**

**AN EVALUATION OF SPACE SHUTTLE  
STS-2 PAYLOAD BAY ACOUSTIC DATA  
AND COMPARISON WITH PREDICTIONS**

**J. F. WILBY  
A. G. PIERSOL  
E. G. WILBY**

**BOLT BERANEK AND NEWMAN INC.  
Canoga Park, California 91303**

**Contract No. NAS5-26570**

**August 1982**

(NASA-CR-170451) AN EVALUATION OF SPACE  
SHUTTLE STS-2 PAYLOAD BAY ACOUSTIC DATA AND  
COMPARISON WITH PREDICTIONS (Bolt, Beranek,  
and Newman, Inc.) 70 p HC A04/MF A01

**N83-13148**



**National Aeronautics and  
Space Administration**

**Goddard Space Flight Center  
Greenbelt, Maryland 20771**

**Unclass  
02156**

**CSCL 22B G3/16**



BBN Report 4748  
BBN Project 08624

AN EVALUATION OF SPACE SHUTTLE STS-2 PAYLOAD BAY  
ACOUSTIC DATA AND COMPARISON WITH PREDICTIONS

John F. Wilby  
Allan G. Piersol  
Emma G. Wilby

Bolt Beranek and Newman Inc.  
Canoga Park, CA 91303

Contract NAS5-26570

July 1982

National Aeronautics and Space Administration  
Goddard Space Flight Center  
Greenbelt, Maryland 20771

TABLE OF CONTENTS

<u>Section</u>	<u>Page</u>
TABLE OF CONTENTS . . . . .	1
LIST OF FIGURES . . . . .	111
LIST OF TABLES . . . . .	v
1.0 INTRODUCTION . . . . .	1
2.0 MICROPHONE LOCATIONS . . . . .	2
3.0 GENERAL ASSESSMENT OF ACOUSTIC DATA . . . . .	8
4.0 EVALUATION OF INTERIOR ACOUSTIC DATA . . . . .	10
4.1 Summary of STS-2 Data . . . . .	10
4.2 Comparison to STS-1 Data . . . . .	17
4.3 Alternate Evaluation of STS-2 Data . . . . .	20
5.0 EVALUATION OF THE EXTERIOR ACOUSTIC DATA . . . . .	24
5.1 Summary of STS-2 Data . . . . .	24
5.2 Comparisons to STS-1 Data . . . . .	24
5.3 Estimation of Space-Average Sound Levels . . . . .	30
5.4 Data Input for PACES . . . . .	44
6.0 PACES CALCULATIONS . . . . .	49
6.1 Interior Space-Average Sound Levels . . . . .	49
6.2 Empty Bay Representation. . . . .	49
6.3 Representation with a Single Payload. . . . .	51

TABLE OF CONTENTS

<u>Section</u>	<u>Page</u>
6.4 Representation with Two Subvolumes. . . . .	53
6.5 Comparison with Measured Data . . . . .	55
6.6 Influence of Vents. . . . .	60
7.0 CONCLUSIONS. . . . .	61

## LIST OF FIGURES

<u>Figure No.</u>	<u>Page</u>
1. Payload Bay Configuration for STS-2. . . . .	4
2. Microphone Locations On DFI Payload for STS-2. . . . .	5
3. Microphone Locations On OSTA-1 Payload for STS-2 . . . . .	6
4. Locations of Microphones Which Provided Data On Exterior Sound Field for STS-2. . . . .	7
5. Space-Average Sound Pressure Levels In Payload Bay With 95% Confidence Limits (STS-2 Lift-Off) . . . . .	14
6. Space-Average Sound Pressure Levels In Payload Bay with Range of Levels (STS-2 Lift-Off). . . . .	15
7. Measure Payload Bay Sound Pressure Levels At Similar Locations During STS-1 and STS-2 Lift Offs . . . . .	18
8. Space-Average Sound Pressure Levels in Payload Bay (STS-1 and STS-2 Lift-Off) . . . . .	19
9. Alternative Estimate of Space-Average Sound Pressure Levels in Payload Bay for STS-2 . . . . .	23
10. One-Third Octave Band Sound Pressure Levels At Exterior Locations During STS-1 and STS-2. . . . .	26
11. Estimated One-Third Octave Band Sound Pressure Levels At Microphone Location 681 During STS-2 . . . . .	32

**LIST OF FIGURES**  
(Continued)

<u>Figure No.</u>	<u>Page</u>
12. Sound Levels on Payload Bay Doors (STS-2) . . . . .	34
13. Comparison of Space-Average Sound Levels On Payload Bay Door (STS-1 and STS-2) . . . . .	36
14. Sound Levels on Mid-Fuselage Sidewall (STS-2) . . . . .	37
15. Comparison of Space-Average Sound Levels On Mid-Fuselage Sidewall (STS-1 and STS-2) . . . . .	39
16. Sound Levels on Mid-Fuselage Bottom Structure (STS-2) . . . . .	41
17. Sound Levels on Mid-Fuselage Bottom Structure (STS-2) . . . . .	42
18. Sound Levels on Mid-Fuselage Bottom Structure (STS-1 and STS-2) . . . . .	43
19. Sound Levels on Payload Bay Aft Bulkhead (STS-1 and STS-2) . . . . .	45
20. Space-Average Sound Levels for Exterior of Payload Bay Estimated from STS-2 Data . . . . .	46
21. Space-Average Sound Levels for Exterior of Payload Bay Estimated from STS-1 Data . . . . .	48
22. Predicted Space-Average Sound Pressure Levels in Empty Payload Bay at Lift-Off (STS-1 and STS-2) . . . . .	52

LIST OF FIGURES  
(Continued)

<u>Figure No.</u>		<u>Page</u>
23.	Payload Bay Sound Levels Predicted by PACES for Single Volume Representations With and Without Volume-Displacing Payload . . . . .	54
24.	Payload Bay Sound Levels Predicted by PACES for Single Volume and Two-Subvolume Representations With Volume-Displacing Payloads . . . . .	56
25.	Comparison of Predicted (Single Volume With Payload) and Measured (Bias Error Correction Method) Sound Levels. . . . .	58
26.	Comparison of Predicted (Single Volume With Payload) and Measured (Four-Volume Average) Sound Levels. . . . .	59



## LIST OF TABLES

<u>Table No.</u>		<u>Page</u>
1.	Summary of Microphone Locations for STS-2. . . . .	3
2.	One-Third Octave Band Sound Pressure Levels in the Payload Bay During STS-2 Lift-Off. . . . .	11
3.	Comparison of Overall Sound Pressure Levels During STS-1 and STS-2 Lift-Offs . . . . .	17
4.	Microphone Locations in Various Regions of the Payload Bay for STS-2. . . . .	21
5.	Alternate Estimates of Space-Average Sound Pressure Levels in the Payload Bay During STS-2 Lift-Off . . . . .	22
6.	One-Third Octave Band Sound Pressure Levels Exter- ior to the Payload Bay During STS-2 Lift-Off . . .	25
7.	One-Third Octave Band Sound Pressure Levels at Exterior Microphone 681. . . . .	31
8.	Exterior Space-Average Sound Pressure Levels for STS-2. . . . .	47
9.	Estimated Absorption Coefficients for Payload Bay. . . . .	50
10.	Assumed Absorption Coefficients for STS-2 Payload Surfaces . . . . .	53

## 1. INTRODUCTION

During the Flight Readiness Firing (FRF) and the first launch (STS-1) of the Space Shuttle, sound pressure level measurements were made at four locations inside the orbiter payload bay and at various locations on the exterior of the orbiter vehicle. These limited data were used to make preliminary evaluations of the "Payload Acoustic Environment for Shuttle (PACES)" computer program developed by Bolt Beranek and Newman Inc. (BBN) [1]. The preliminary evaluations using the FRF and STS-1 data are presented in [2,3]. During the second launch (STS-2) of the Space Shuttle, sound pressure levels were measured at eighteen locations inside the orbiter payload bay providing the first substantial sample of acoustic data needed for a more accurate verification of the PACES computer model and, independently, an assessment of the payload bay acoustic levels under actual launch conditions. This report summarizes the analysis and evaluations of the STS-2 data for such purposes.

The data available for the analyses herein were provided by the NASA "30-Day Report" [4] and by subsequent additional data reduction performed by NASA at BBN's request. The basic approach followed in the analyses is as detailed in [5], but there are two deviations. As for STS-1, data were not available for all the exterior microphone locations identified in [5]. Consequently, the data analysis procedure for the exterior sound pressure level measurements was modified somewhat from that outlined in [5]. The actual procedure used is similar to that followed in the earlier reports which covered the results of the FRF [2] and STS-1 [3]. More importantly, since the data for STS-1 and STS-2 show an increase in the payload bay sound pressure levels as the measurement location moves forward, an alternative data analysis procedure is introduced whereby the bay is divided into four regions, and average sound pressure levels determined for each region.

## 2. MICROPHONE LOCATIONS

During the STS-2 launch, sound pressure levels were measured inside the payload bay of the orbiter vehicle, on the exterior of the vehicle and in the aft fuselage. Concerning first the measurements inside the payload bay, a total of eighteen microphones were mounted on the payload bay structure, the DFI payload and the OSTA payload, as detailed in Table 1. The first three microphones (I1 through I3) were mounted on the orbiter structure as shown in Figure 1. The next eight microphones (I4 through I11) were mounted on the DFI payload as shown in Figure 2. The last seven microphones were mounted on the OSTA Payload as shown in Figure 3. Note that the detailed locations given in Table 1 are taken directly from the NASA "30-day" report [4] covering the STS-2 flight and are different in some cases from the tentative locations presented in the report covering the preflight bias error correction study [5]. However, the differences are not considered sufficient to influence the conclusions drawn in [5].

Now concerning the exterior measurements, a number of flush mounted microphones were installed on the fuselage and wing of the orbiter vehicle, and data from twelve of these microphones were available for analysis. One final microphone located in the aft fuselage section also provided data. The locations of these microphones are illustrated in Figure 4. Note that these locations are the same as for the exterior and aft fuselage microphones on STS-1 [3], except for two additions (206 and 689 malfunctioned on STS-1) and two deletions (681 and 194 malfunctioned on STS-2). The frequency range of the exterior and aft fuselage microphones was stated in the "30-day" report [4] to be 20 Hz to 8kHz.

Table 1. Summary of Microphone Locations For STS-2

General Location	BBN Code	NASA Code	Station Number			Frequency Range*
			X	Y	Z	
Bay Structure	I1	V08Y9405A	576	+4	423	A
	I2	V08Y9219A	863	-100	381	A
	I3	V08Y9403A	1306	+12	400	A
DFI Payload	I4	V08Y9220A	1159	0	427	A
	I5	V08Y9279A	1192	+15	384	B
	I6	V08Y9277A	1219	-68	432	B
	I7	V08Y9281A	1219	-68	384	A
	I8	V08Y9278A	1194	-44	328	B
	I9	V08Y9276A	1139	+20	384	B
	I10	V08Y9280A	1139	+68	432	A
	I11	V08Y9275A	1139	-68	432	B
	OSTA Payload	I12	V08Y9253A	978	-29	410
I13		V08Y9252A	864	-29	410	B
I14		V08Y9254A	951	-45	394	B
I15		V08Y9257A	832	+29	427	A
I16		V08Y9258A	1001	+29	427	A
I17		V08Y9256A	951	-85	398	B
I18		V08Y9255A	951	0	326	B

\*A-20 Hz to 8kHz; B-5 Hz to 2kHz

ORIGINAL PAGE IS  
OF POOR QUALITY

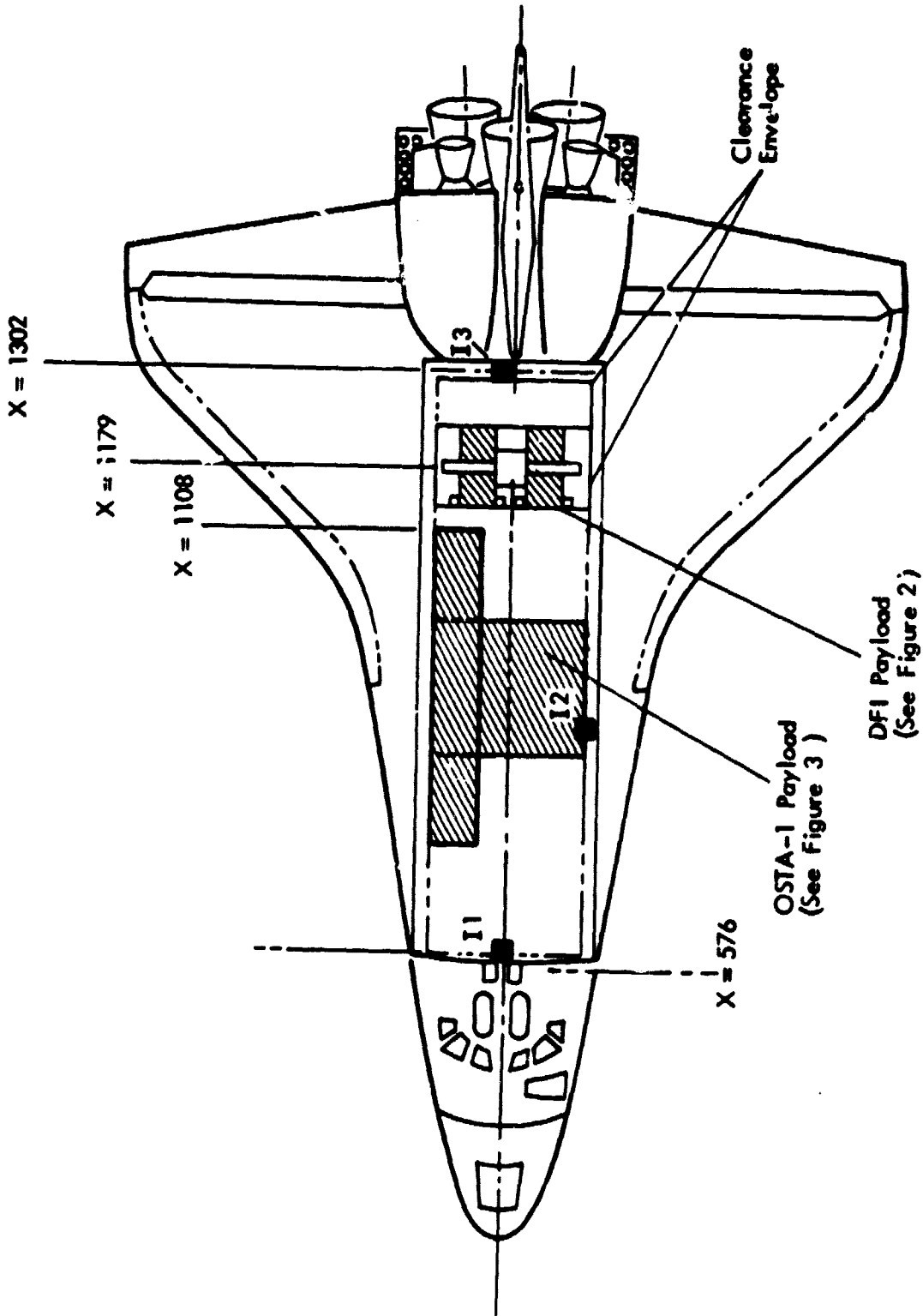

FIGURE 1. PAYLOAD BAY CONFIGURATION FOR STS-2

ORIGINAL PAGE IS  
OF POOR QUALITY

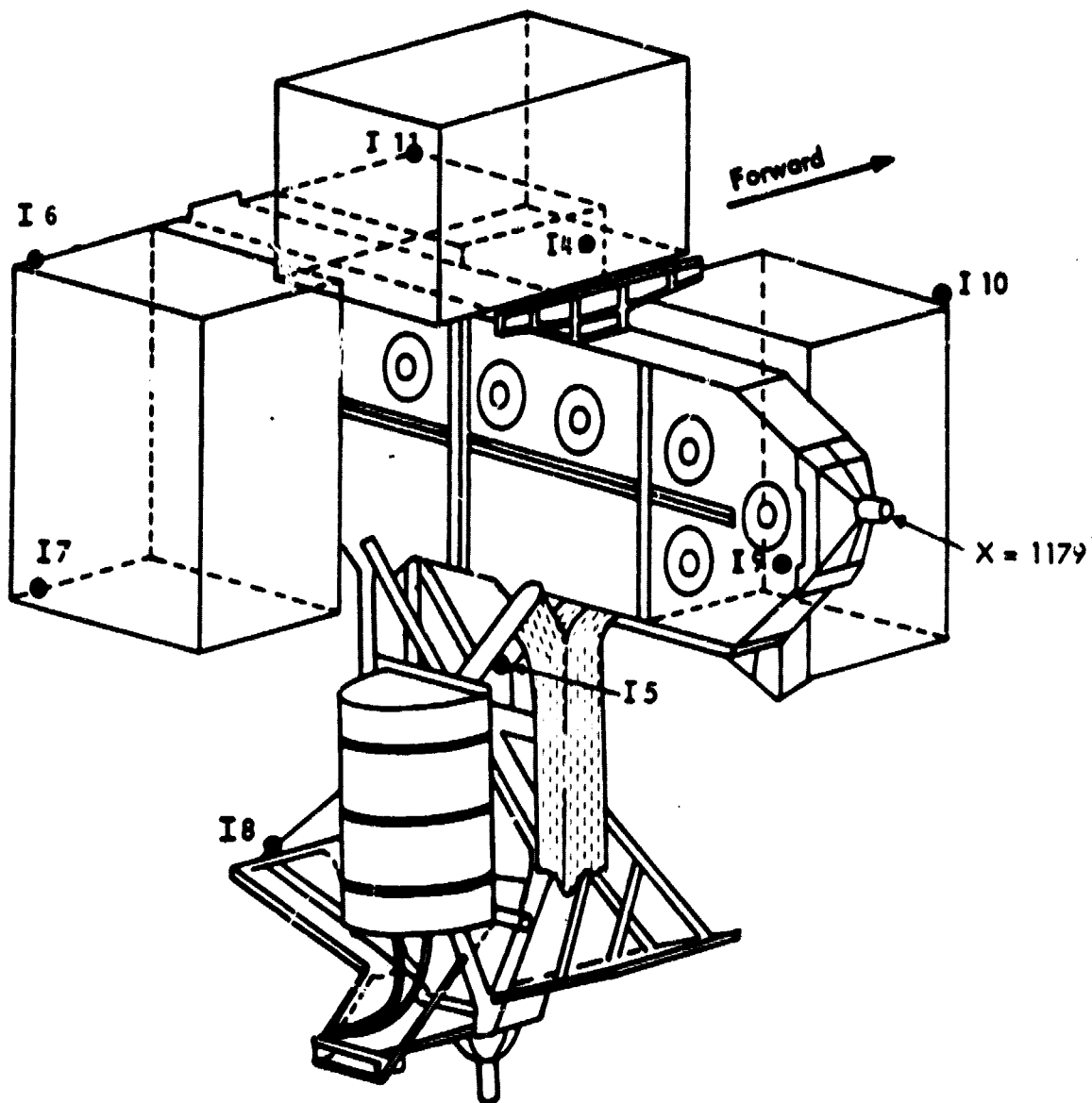

FIGURE 2. MICROPHONE LOCATIONS ON DFV PAYLOAD FOR STS-2

ORIGINAL PARTS  
OF POOR QUALITY

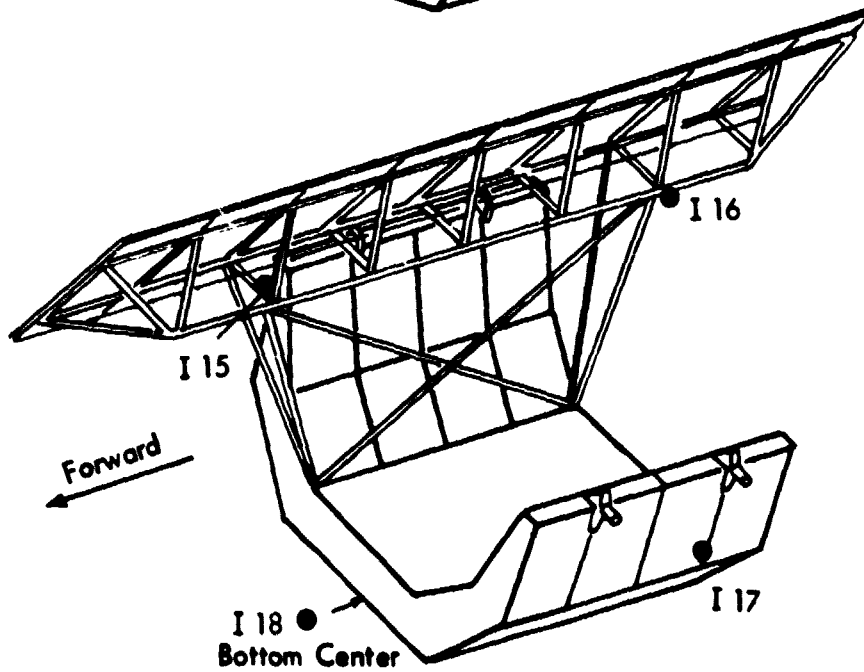
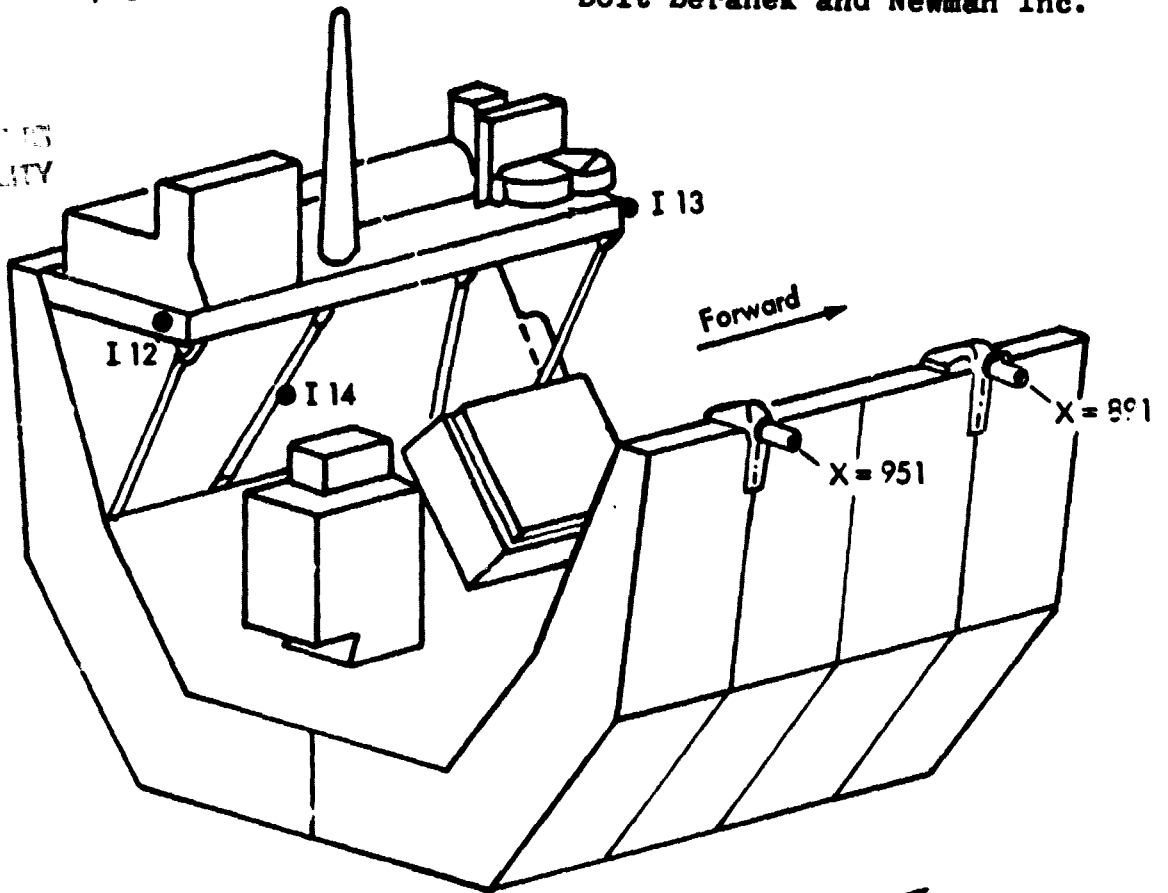

FIGURE 3. MICROPHONE LOCATIONS ON OSTA-1 PAYLOAD FOR STS-2

ORIGINAL PAGE IS  
OF POOR QUALITY

- External Microphones
- Aft Fuselage Microphone
- ⊗ Under-wing Microphone

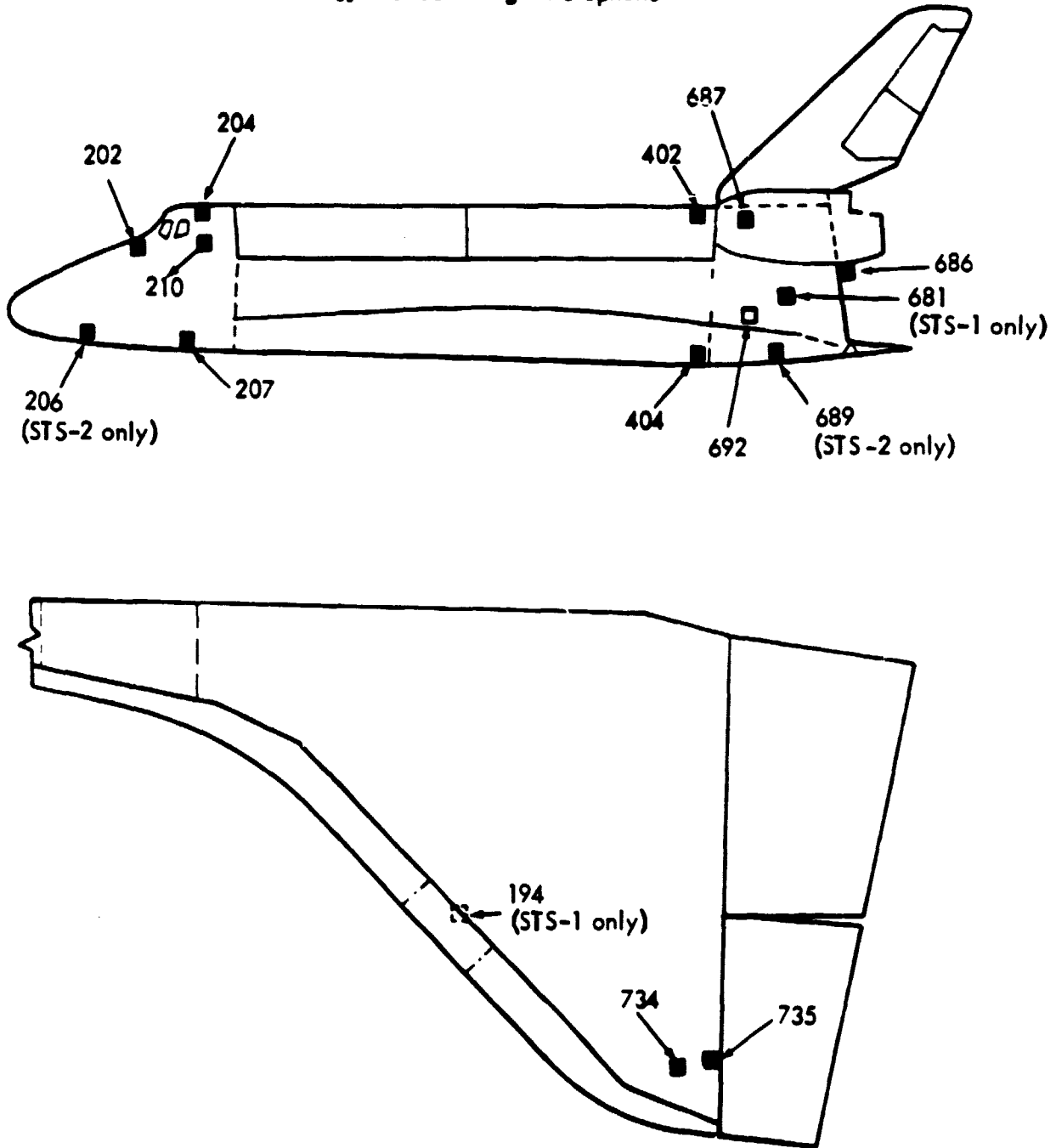

FIGURE 4. LOCATIONS OF MICROPHONES WHICH PROVIDED DATA ON EXTERIOR SOUND FIELD FOR STS-2



### 3. GENERAL ASSESSMENT OF ACOUSTIC DATA

As for the STS-1 data [2], some of the STS-2 data presented in the "30-Day" report [4] and provided separately by NASA are of marginal quality. Two critical exterior microphones mounted at the forward end of the payload bay doors and on the aft fuselage sidewall (401 and 681 in [5]) produced unusable data during lift-off. A few other microphone channels experienced momentary loss of signal later in the flight, but not during lift-off. At high frequencies, all the interior microphone signals had a poor signal-to-noise ratio, which sometimes fell below 10 dB at frequencies above 800 Hz. This was particularly noticeable for microphones with an upper cut-off frequency of only 2 kHz. Finally, at frequencies below 100 Hz, the interior levels measured on the forward bulkhead (I1) are generally higher than the levels measured at all other locations including aft bulkhead. This same result occurred on STS-1 [3] and is contrary to expectations, but there is still no physical evidence to challenge the validity of the forward bulkhead measurement.

The data were analyzed in terms of rms values in one-third octave bands expressed in dB referenced to 20 Pa. The one-third octave band levels were determined from the maximum value of continuous rms levels in each one-third octave band computed with an averaging time of 0.5 seconds over the time interval from  $T = 0$  to  $T + 10$  seconds ( $T = 0$  is the time of the SRB ignition). In almost all cases, the maximum one-third octave band levels during lift-off occurred within this time interval, usually around  $T + 5$  seconds. The one-third octave band levels were also computed at  $T + 120$  seconds to establish a noise floor for the instrumentation (at  $T + 120$  seconds, the flight altitude is about 50 km and airborne acoustic noise is negligible). This procedure is the same as that followed in [3] for STS-1; in the STS-1 report the time interval was referred to as " $T - 6$  to  $T + 12$  seconds", although only those maxima occurring in the interval  $T = 0$  to  $T + 10$  were used in the analysis.

The one-third octave band levels used for the analyses in this report were corrected for background noise by the following procedures.

1. If the maximum level during lift-off is at least 10 dB above the background noise, no correction is applied to the data.
2. If the maximum level during lift-off is at least 3 dB but less than 10 dB above the background noise, the data are corrected for background noise using the relationship,

$$\text{corrected dB} = 10 \log \left[ 10^{(\text{dB}_r/10)} - 10^{(\text{dB}_b/10)} \right] \quad (1)$$

where  $\text{dB}_r$  is the sound pressure level as read during liftoff and  $\text{dB}_b$  is the background noise level.

3. If the maximum level during liftoff is less than 3 dB above the background noise, the data are considered too contaminated by noise to be useful and are discarded.

As a final point concerning the basic data analysis in [4], many of the interior microphones and all of the exterior microphones are listed in [4] as having a frequency range from 20 Hz to 8kHz, as previously detailed in Table 1. Nevertheless, the NASA data analysis was performed over a frequency range starting with the 12 Hz one-third octave band for all microphones. It is assumed here that NASA believes that the microphones rated with a 20 Hz to 8kHz frequency range will still provide acceptable data down to 12 Hz.

#### 4. EVALUATION OF THE INTERIOR ACOUSTIC DATA

The initial plan for the analysis of the STS-2 data was based on the bias error correction study of [5], and this analysis is discussed in Section 4.1. During data analysis, however, it was noted (see Section 3.0) that the measured sound levels were higher at the front of the bay than at the rear. Thus an alternative analysis procedure was introduced in an attempt to account for the spatial variation. This analysis is discussed in Section 4.3.

##### 4.1 Summary of STS-2 Data

The maximum one-third octave band levels measured during the lift-off phase ( $T = 0$  to  $T + 10$  seconds) by the eighteen microphones inside the payload bay are detailed in Table 2. Also shown in Table 2 are the energy averages of the eighteen microphones, 95% confidence limits for the true energy average levels, and the range limits for the individual measurements.

The energy averages in Table 2 are computed from

$$L_{ea} = 10 \log \left[ \frac{\sum_{i=1}^n 10^{(L_i/10)}}{n} \right] \quad (2)$$

where  $L_i$  is the sound pressure level in dB measured by the  $i$ th microphone and  $n$  is the number of measurements (a maximum of 18). From the bias error correction study in [5], it was concluded that the locations of the STS-2 payload bay microphones were sufficiently distributed to provide an approximately unbiased sample of the acoustic levels in the payload bay volume. Hence, the energy averaged values in Table 2 can be considered estimates of the space-average sound pressure levels in the payload bay.

Table 2. One-Third Octave Band Sound Pressure Levels in the Payload Bay During STS-2 Lift-Off

Freq. Hz.	One Third Octave Band Sound Pressure Level, dB (ref: 20 $\mu$ Pa)												
	Y9405A I1	Y9219A I2	Y9403A I3	Y9220A I4	Y9279A I5	Y9277A I6	Y9281A I7	Y9278A I8	Y9276A I9	Y9280A I10	Y9275A I11	Y9253A I12	
12	119.0	112.0	117.0	109.0	116.2	116.0	116.0	117.0	111.0*	108.0	109.5*	111.1*	
16	123.0	116.5	118.0	107.0	112.0	115.6	116.0	114.0	104.0*	106.0	104.0*	117.1	
20	119.5	115.0	114.5	105.0	108.0	112.0	111.5	109.0	109.0	108.8	111.0	115.0	
25	120.5	118.6	115.5	113.5	110.1*	112.0*	112.0	109.7*	114.6	114.0	115.0	114.8	
31	121.5	119.5	112.0	115.0	112.0	114.0	110.0	114.0	113.0	116.0	117.1	116.4	
40	126.0	123.0	114.5	114.0	117.0	117.0	112.5	117.5	117.0	116.8	120.0	117.0	
50	127.5	123.5	115.0	117.0	115.0	120.0	115.0	116.7	117.0	118.0	121.0	120.0	
63	129.5	127.5	116.5	117.0	118.0	119.0	115.0	119.0	117.0	120.0	121.0	121.9	
80	129.5	127.5	121.5	121.0	119.0	123.0	120.0	122.0	118.0	120.0	122.0	122.0	
100	128.0	127.0	121.0	122.0	121.0	122.5	123.0	124.0	120.5	122.0	124.1	123.0	
125	126.5	126.0	123.0	122.0	123.0	120.0	123.0	124.0	121.6	120.0	123.0	123.0	
160	125.0	125.0	125.0	122.0	121.0	118.0	119.5	122.0	123.0	121.0	123.0	122.0	
200	128.0	123.0	124.5	123.5	124.5	120.0	121.0	121.5	122.5	122.0	123.0	124.0	
250	124.0	124.0	125.0	122.5	122.0	121.4	119.0	122.0	120.0	123.0	123.5	122.0	
315	122.0	120.0	124.0	119.8	119.8	121.0	120.0	119.0	**	121.0	122.7	121.2	
400	119.0	118.0	120.0	117.0	116.6	118.0	116.5	**	119.0	120.0	120.0	120.0	
500	118.0	118.0	116.5	115.0	116.0	116.0	114.8	117.0	118.0	119.0	118.5	119.1	
630	114.0	116.0	119.5	112.0	114.0	115.9	115.0	117.5	118.0	115.0	116.0	117.5	
800	113.0	114.5	111.5	112.5	110.2	111.0*	112.0	117.4*	118.0	113.0	114.2*	118.0	
1000	112.0	114.0	109.0	110.0	**	**	109.0	117.4*	119.0*	110.0	**	120.0	
1250	111.0	111.0*	106.0*	110.0	**	**	108.0	119.0*	121.5*	110.0	113.3*	120.3*	
1600	109.0	111.0	105.1*	110.0	**	**	106.2*	121.0*	121.3*	109.0	**	121.9*	
2000	109.0	111.0	106.1*	109.0	**	**	105.5*	121.7*	118.8*	108.0*	**	120.8*	

\*Corrected for background noise

\*\*Background noise too large to be corrected

ORIGINAL PAGE IS OF POOR QUALITY

Table 2. (Continued)

Freq. Hz.	One Third Octave Band Sound Pressure Level, dB (ref: 20 µPa)										Range of Values	
	Y9252A I13	Y9254A I14	Y9257A I15	Y9258A I16	Y9256A I17	Y9255A I18	Energy Average	95% Conf. Limits		Lower	Upper	
	Lower	Upper	Lower	Upper	Lower	Upper						
12	108.8	110.7*	106.4*	112.6	113.5	110.0	113.9	111.5	115.4	106.4	119.0	
16	113.6	117.9	111.9	118.0	118.1	118.0	116.4	113.2	118.2	104.0	123.0	
20	113.7	115.6	112.8	114.8	115.5	119.2	114.3	111.7	115.9	105.0	119.5	
25	117.1	112.0	117.6	113.5	117.0	118.0	115.7	113.8	117.0	109.7	120.5	
31	115.0	116.2	113.9	115.0	120.7	117.0	116.5	114.3	118.0	110.0	121.5	
40	119.0	119.0	115.0	115.0	122.8	118.5	119.4	116.0	121.2	112.5	126.0	
50	121.0	121.1	121.0	117.0	128.8	123.5	122.0	117.8	124.1	115.0	128.8	
63	121.0	122.7	123.0	120.0	128.0	121.4	123.0	119.1	125.1	115.0	129.5	
80	122.0	123.6	122.0	120.5	128.5	125.2	123.9	121.2	125.6	119.0	129.5	
100	122.0	125.0	122.7	123.0	125.6	124.0	123.9	122.4	124.9	120.5	128.0	
125	122.8	124.0	125.0	123.0	130.4	126.0	124.5	122.3	125.9	120.0	130.4	
160	122.8	121.4	124.4	123.5	128.5	122.5	123.4	121.7	124.6	118.0	128.5	
200	122.2	121.4	123.0	125.0	130.0	123.8	124.3	122.1	125.8	120.0	130.0	
250	121.5	119.9	122.6	124.0	127.3	120.0	122.9	121.5	124.0	119.0	127.3	
315	121.0	117.9	120.0	120.0	125.6	120.5	121.2	119.8	122.3	117.9	125.6	
400	117.8	116.7	117.8	120.0	123.5	116.8	119.0	117.6	120.1	116.5	123.5	
500	117.0	115.8	116.0	118.8	122.0	115.5	117.6	116.3	118.6	114.0	122.0	
630	115.0	114.0	114.8	116.6	119.0	113.8	116.2	115.0	117.1	112.0	119.5	
800	111.3*	112.0*	112.3	114.5	117.8	112.1*	114.4	112.6	115.6	110.2	118.0	
1000	109.2*	113.8*	111.0	112.0	119.0	111.0*	114.9	111.3	116.3	109.0	120.0	
1250	**	113.8*	119.0	111.0	119.9*	112.6*	116.3	112.4	118.3	106.0	121.5	
1600	**	**	108.3*	109.5	119.9*	114.4*	116.7	110.4	119.1	105.1	121.9	
2000	**	**	106.3*	108.7*	116.6*	**	115.7	106.8	118.4	105.5	121.7	

\*Corrected for background noise  
\*\*Background noise too large to be corrected

The 95% confidence limits for the true energy (space)-average levels are defined by [6]:-

$$\text{upper 95\% limit} = 10 \log \left[ \bar{l}_{ea} + \frac{t_{m;0.025}}{\sqrt{n}} s_l \right] \quad (3a)$$

$$\text{lower 95\% limit} = 10 \log \left[ \bar{l}_{ea} - \frac{t_{m;0.025}}{\sqrt{n}} s_l \right] \quad (3b)$$

where

$$\bar{l}_{ea} = 10^{L_{ea}/10}$$

$$s_l = \left[ \frac{1}{n-1} \sum_{i=1}^n (l_i - \bar{l}_{ea})^2 \right]^{1/2}$$

$$l_i = 10^{L_i/10}$$

$n$  = sample size (generally  $n = 18$  except at the higher frequencies where the poor S/N ratio reduces the number of valid measurements)

$t_{m; 0.025} = 0.025$  percentage point of Student "t" variable with  $m = n - 1$  degrees-of-freedom.

The resulting space-average sound pressure level estimates and the 95% confidence intervals for the true space-average sound pressure levels are shown in Figure 5. Note that the width of the confidence interval in Figure 5 expands dramatically at frequencies above 800 Hz to a width of almost 12 dB at 2000 Hz. Some of this increased interval width is due to the reduced number of valid measurements (reduced sample size) at the higher frequencies. However, a significant increase in the scatter of the individual measurements at the higher frequencies is also an important contributor to this result.

The space-average sound pressure level estimates are shown again in Figure 6 with bounds representing the full range of values for the individual measurements in each one-third octave

ORIGINAL TITLE IS  
OF POOR QUALITY

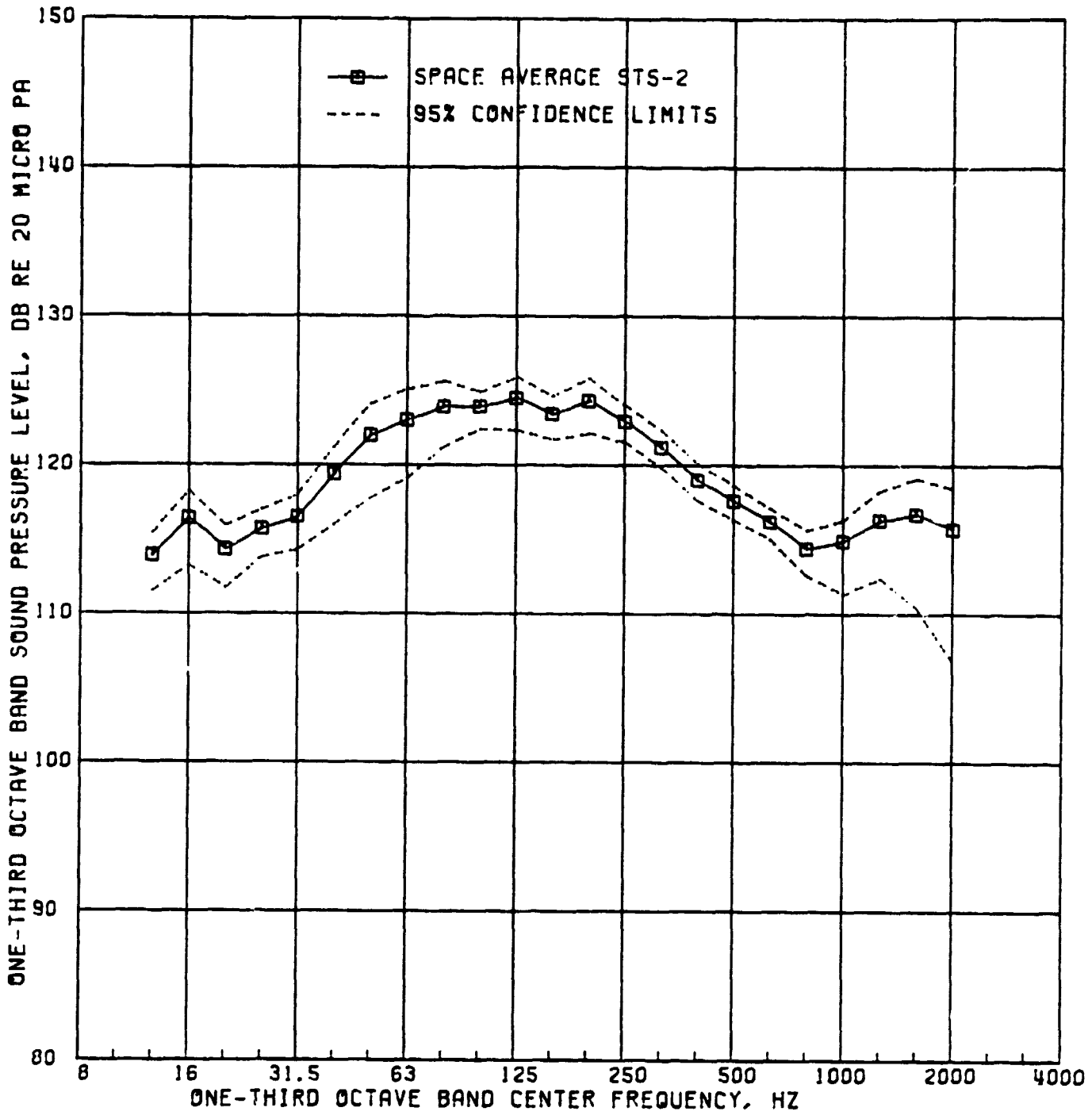

FIGURE 5. SPACE-AVERAGE SOUND PRESSURE LEVELS IN PAYLOAD BAY WITH 95% CONFIDENCE LIMITS (STS-2 LIFT-OFF)

ORIGINAL FIGURE IS  
OF POOR QUALITY

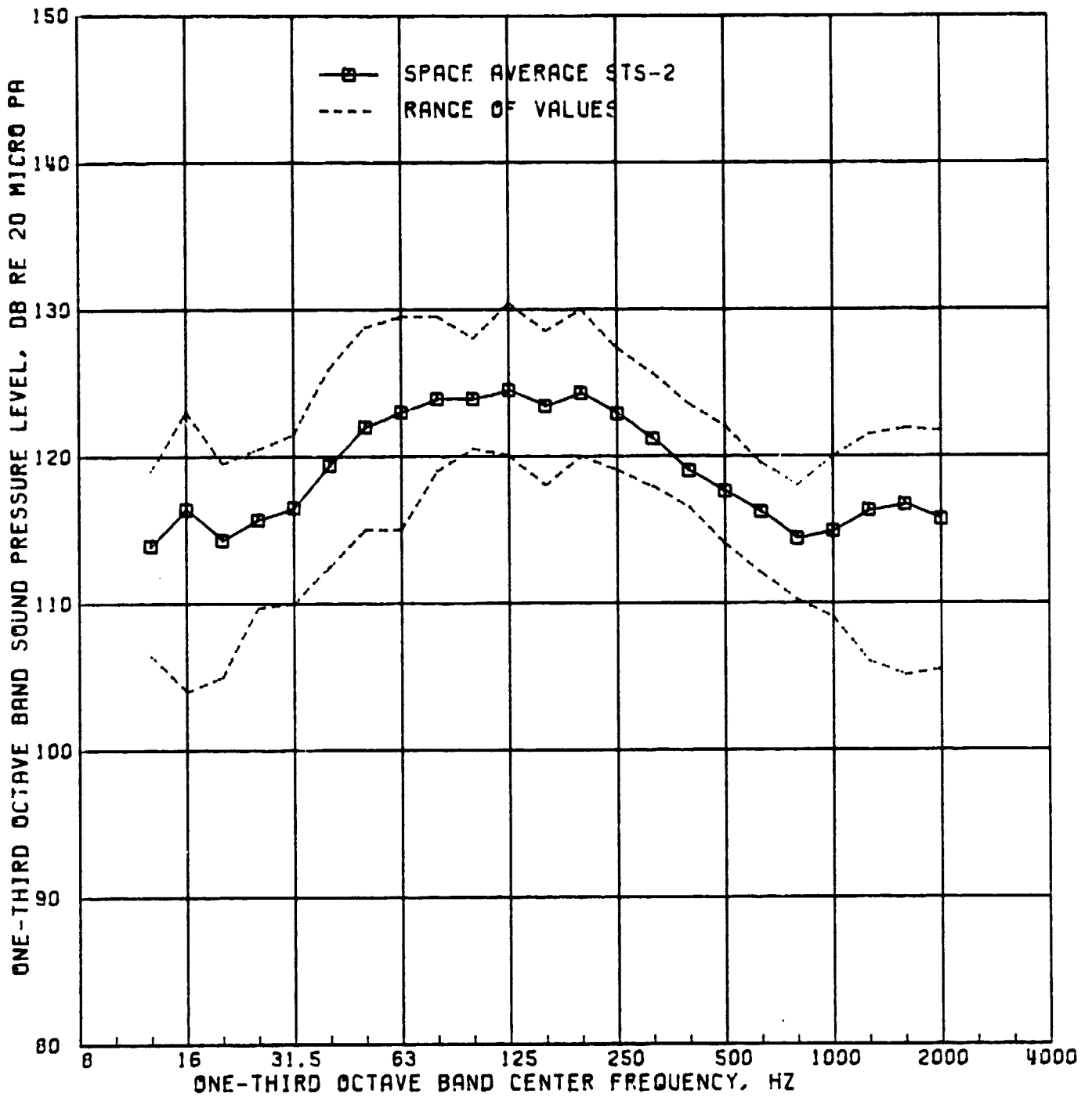

FIGURE 6. SPACE-AVERAGE SOUND PRESSURE LEVELS IN PAYLOAD BAY WITH RANGE OF LEVELS (STS-2 LIFT-OFF)



band frequency interval. Note that the range of individual values is relatively wide at the lower frequencies and decreases with increasing frequency up to about 800 Hz. This is consistent with expectations for the spatial scatter of sound pressure levels in a semi-reverberant enclosure [7]. However, the range of individual values again increases above 800 Hz. An inspection of the data in Table 2 reveals that the highest levels in this upper frequency region tend to cluster on the DFI payload and the aft region of the OSTA payload.

As a final point of interest concerning the results in Figure 6, the range of individual measurements can be interpreted as a nonparametric tolerance interval for the sound pressure levels throughout the payload bay using the relationship [6]

$$\gamma = 1 - \beta^n - n(1-\beta)\beta^{n-1} \quad (4)$$

where  $\gamma$  is the confidence coefficient associated with the following statement: "the sound pressure levels for at least 100 $\beta$  % of all locations inside the payload bay will fall between the maximum and minimum measured values for the  $n$  samples shown in Figure 6." For the data in the one-third octave bands below 1000 Hz where the sample size is constant at  $n = 18$ , Eq (4) is satisfied by  $\gamma = 0.90$  and  $\beta = 0.78$ . Hence it can be stated with 90% confidence that the sound pressure levels for at least 78% of the locations inside the payload bay will fall between limits shown in Figure 6. The above statement is correct independent of the probability density function of the sound pressure levels throughout the bay (it is a nonparametric statement). On the other hand, it is assumed in making the statement that the  $n$  locations providing measurements were selected at random. The selection of the microphone locations on STS-2 was of course not random, but the studies in [5] suggest the selected locations represent a reasonably unbiased sample of the payload bay acoustic levels.

#### 4.2 Comparisons to STS-1 Data

Three of the interior microphones on STS-2 were at identically the same locations as microphones on STS-1, namely, microphones I1 through I3 in Table 1 and Figure 1. Direct comparisons of the one-third octave band sound pressure levels measured at these three locations during the STS-1 and STS-2 lift-offs are shown in Figure 7. It is seen in this figure that the acoustic levels for the two launches are significantly different in some one-third octave band intervals, but the differences display no consistent trend. Furthermore, the overall levels for the two launches at each of the three locations agree to within 1 dB, as detailed in Table 3.

**Table 3. Comparison of Overall Sound Pressure Levels  
During STS-1 and STS-2 Lift-Offs**

Microphone Location (See Table 1 and Figure 1)		Overall Sound Pressure Level, dB (12 Hz to 2kHz)	
BBN Code	NASA Code	STS-1	STS-2
I1	V08Y9405A	136.9	137.8
I2	V08Y9219A	135.1	135.8
I3	V08Y9403A	133.5	133.4
Space-Average Estimate		133.9	134.1

Also shown in Table 3 are the overall acoustic levels during lift-off based upon the space average sound pressure level estimates for STS-1 and STS-2. The space average estimate for STS-1 used to compute the overall value in Table 3 includes the reflection corrections discussed in [3,5]. It is clear from the results that there was no major difference in the overall payload bay acoustic levels during the STS-1 and STS-2 lift-offs. However, a comparison of the one-third octave band spectra in Figure 8 shows a consistent reduction in STS-2 levels below 80 Hz compared with the STS-1 levels, and an increase above 800 Hz.

ORIGINAL FIGURES  
OF POOR QUALITY

— STS-2  
- - - STS-1

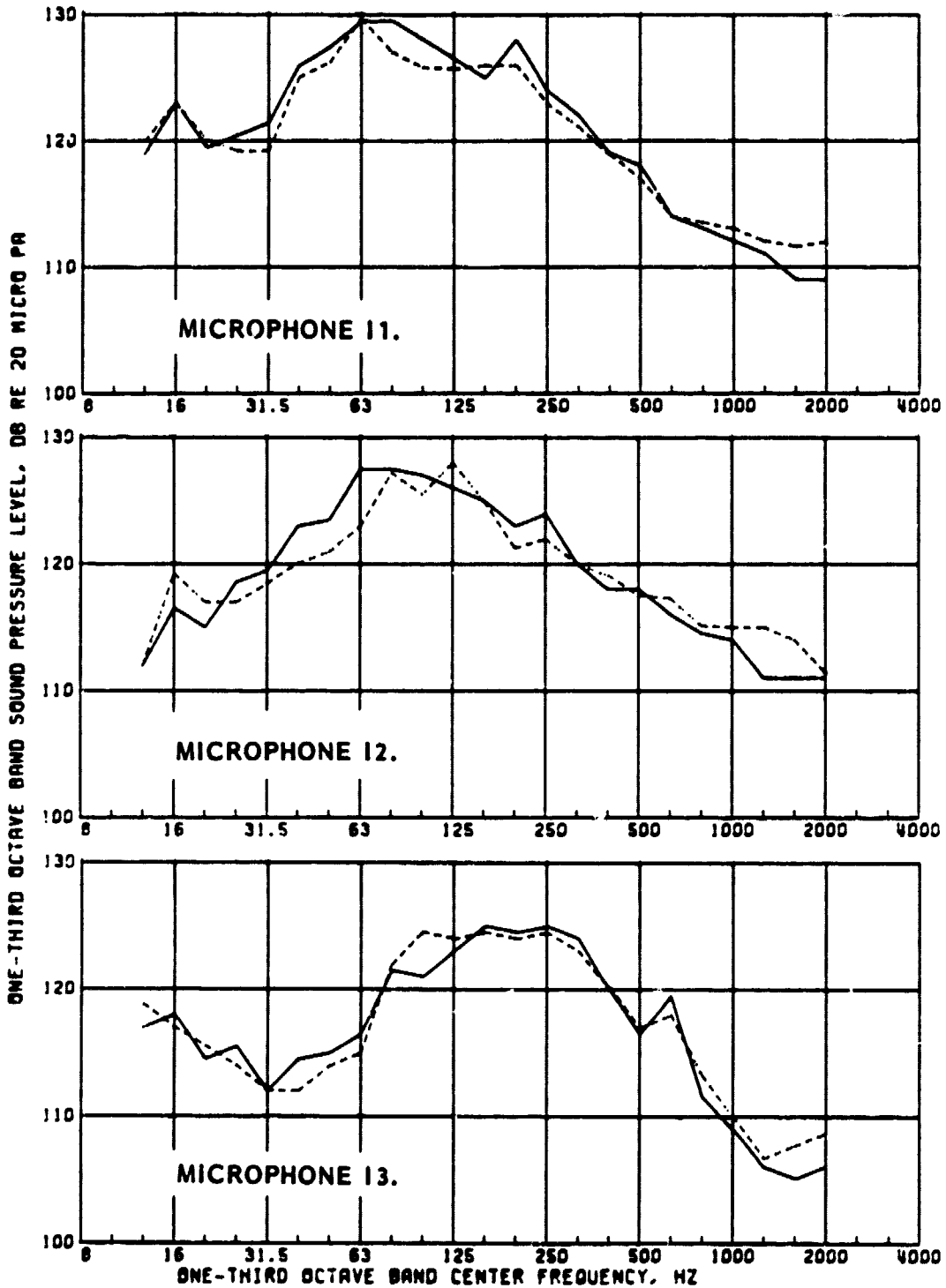

FIGURE 7. MEASURED PAYLOAD BAY SOUND PRESSURE LEVELS AT SIMILAR LOCATIONS DURING STS-1 AND STS-2 LIFT-OFFS

ORIGINAL FIGURES  
OF POOR QUALITY

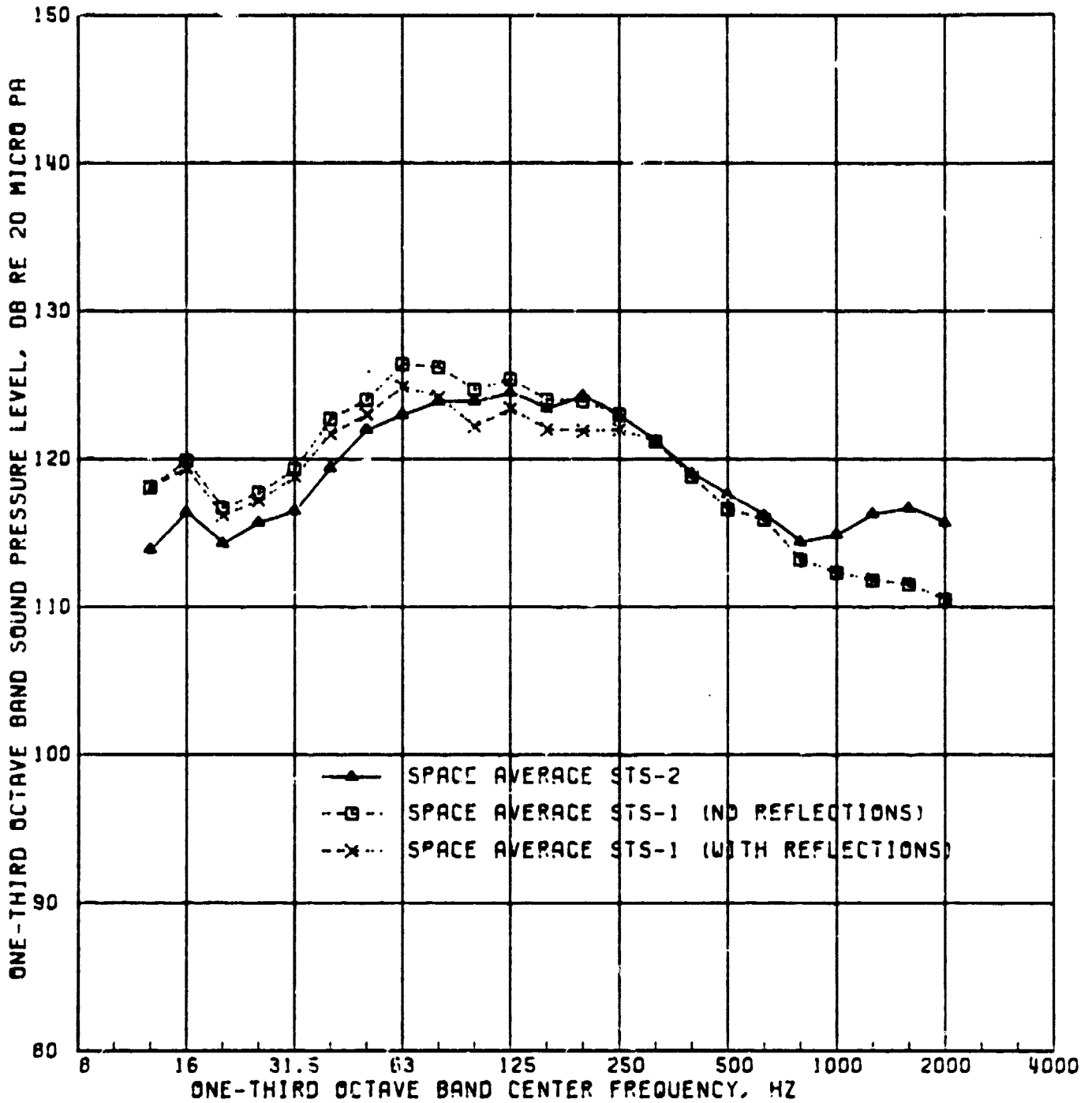

FIGURE 8. SPACE-AVERAGE SOUND PRESSURE LEVELS IN PAYLOAD-BAY (STS-1 AND STS-2 LIFT-OFF)

### 4.3 Alternate Evaluation of STS-2 Data

As noted in Section 3, the sound pressure levels measured at the forward bulkhead (I1) during both the STS-1 and STS-2 launches are generally higher than those measured at other locations in the frequency range below 100 Hz. This is quite different from the results produced by the OV-101 jet noise tests and the Rockwell 1/4 scale model acoustic tests used to generate the bias error correction factors for the STS flight measurements [5]. Those pre-flight experiments suggested the acoustic levels in the forward region of the payload bay would be similar to, or less than, the levels measured in the aft region of the bay, and this conclusion strongly influences the bias error correction factors derived in [5]. Assuming that the forward bulkhead (I1) measurements on STS-1 and STS-2 accurately represent the sound pressure levels in the forward region of the payload bay, it follows that the bias error corrections developed in [5] are not fully appropriate, particularly for the STS-2 measurements where the interior microphones were concentrated in the aft region of the bay; i.e., I1 is the only measurement in the forward one-third of the bay out of a total of 18 measurements on STS-2.

Due to the above problem, it is believed that a more accurate way to estimate the space-average sound pressure levels in the payload bay during the STS-2 lift-off is as follows:

1. Divide the payload bay longitudinally into four regions of equal length.
2. Compute the energy-average of the sound pressure levels measured in each region.
3. Estimate the space-average for the entire payload bay from the energy-average of the average levels computed in the four regions.

The microphone locations which fall in each of the four regions of the payload bay are detailed in Table 4. The energy-average levels in each region and the estimated space-average levels in the payload bay are presented in Table 5. Estimated space-average levels for the bay, and the associated 95% confidence limits are plotted in Figure 9. Also shown in Figure 9 are the estimated space-average levels obtained for the STS-1 data in [3]. Note that neither the STS-1 nor STS-2 estimates in Figure 9 include a correction for reflections.

**Table 4. Microphone Locations in Various Regions of the Payload Bay for STS-2**

Region Identification	Region Bounds (Station Nos.)	Measurement Locations In Region
A	576 - 758	I1
B	759 - 941	I2, I13, I15
C	942 - 1124	I12, I14, I16 - I18
D	1125 - 1307	I3 - I11

The results in Figure 9 show a much better agreement between the space-average levels estimated using the STS-1 and STS-2 data than is revealed in Figure 8. The only significant discrepancies now are in the 12 Hz band and in the bands above 1000 Hz. The discrepancy in the 12 Hz band probably evolves from the fact that the sound pressure levels at these low frequencies are dominated by individual acoustic modes in the bay and, hence, the measured levels are very sensitive to the exact measurement locations. The discrepancies above 1000 Hz are related to the unusually high levels in STS-2 around the aft end of the OSTA payload, as discussed in Section 4.1, and are not fully understood at this time.

**Table 5. Alternate Estimates of Space-Average Sound Pressure Levels in the Payload Bay During SIS-2 Lift-Off**

One-Third Octave Band Center Freq. (Hz)	One-Third Octave Band Sound Pressure Level, dB (ref: 20 $\mu$ Pa)						
	Energy Average by Region				Space-Average Level	95% Conf. Limits	
	A	B	C	D		Lower	Upper
12	119.0	109.7	111.8	114.6	115.2	*	119.2
16	123.0	114.4	117.8	113.3	118.9	*	123.2
20	119.5	113.9	116.4	110.6	116.3	*	119.8
25	120.5	117.8	115.6	113.4	117.6	*	120.8
31	121.5	116.8	117.6	114.2	118.3	*	121.7
40	126.0	120.2	119.3	116.7	122.0	*	126.2
50	127.5	122.0	124.0	117.7	124.1	*	127.8
63	129.5	124.7	123.8	118.4	125.7	*	129.7
80	129.5	124.7	124.9	121.0	126.1	*	129.7
100	128.0	124.5	124.2	122.4	125.3	112.3	128.2
125	126.5	124.8	126.3	122.4	125.3	121.3	127.3
160	125.0	124.2	124.5	122.0	124.1	121.7	125.6
200	128.0	122.7	125.9	122.7	125.4	110.7	128.4
250	124.0	122.8	123.6	122.4	123.2	121.9	124.3
315	122.0	120.4	121.9	121.0	121.4	120.0	122.4
400	119.0	117.9	120.2	118.6	119.0	117.0	120.4
500	118.0	117.1	118.9	116.8	117.9	115.9	119.1
630	114.0	115.3	116.6	116.4	115.7	113.4	117.2
800	113.0	112.9	115.6	114.1	114.0	111.1	115.8
1000	112.0	111.9	116.7	114.5	114.2	105.0	117.0
1250	111.0	116.6	117.2	116.2	115.2	110.1	118.2
1600	109.0	109.8	118.6	116.8	115.4	*	119.3
2000	109.0	109.3	117.6	116.1	114.6	*	118.3

\* Lower bound on 95% confidence interval undefined due to large spatial variability.

ORIGINAL PAGES IS  
OF POOR QUALITY

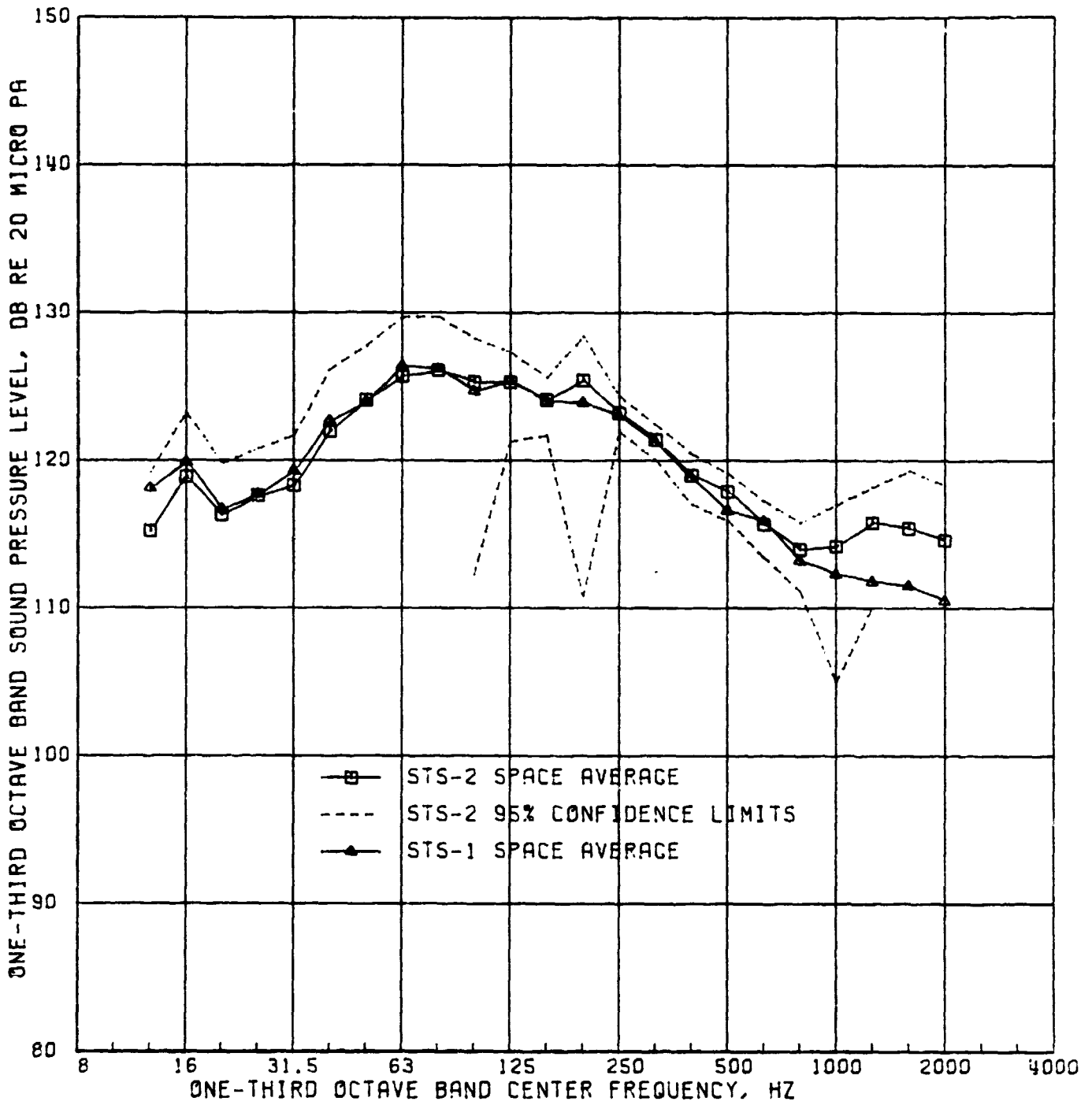

FIGURE 9. ALTERNATIVE ESTIMATE OF SPACE-AVERAGE SOUND PRESSURE LEVELS IN PAYLOAD BAY FOR STS-2



## 5. EVALUATION OF THE EXTERIOR ACOUSTIC DATA

### 5.1 Summary of STS-2 Data

The maximum one-third octave band levels measured during the lift-off phase ( $T=0$  to  $T + 10$  seconds) by the twelve exterior microphones and the aft fuselage microphone are detailed in Table 6. Note that the data for microphone 202 mounted on the nose of the orbiter just forward of the crew windows displayed a very poor signal-to-noise ratio and further have an unusual spectrum raising doubt about the validity of the microphone 202 results. All other exterior microphones, however, produced data with acceptable signal-to-noise ratios and believable spectra.

### 5.2 Comparisons to STS-1 Data

Ten of the twelve exterior microphones plus the aft fuselage microphone on STS-2 also provided data during STS-1 [3]. Direct comparisons of the one-third octave band sound pressure levels measured at these common exterior and aft fuselage locations (excluding microphone 202) during the STS-1 and STS-2 lift-offs are shown in Figure 10. It is seen from Figure 10 that the measured levels during the two launches are broadly similar with a few notable exceptions as follows:

1. Microphone 207 on the forward bottom of the orbiter shows the STS-2 levels to be consistently lower (by 3 to 5 dB) than the STS-1 levels in all frequency bands at this location.
2. All microphones on the exterior aft fuselage (402, 404, 686 and 687) reveal consistently higher levels (by up to 3 dB) in most one-third octave bands above 125 Hz during STS-2.
3. Microphone 735 on the outboard trailing edge of the wing

ORIGINAL PAGES  
OF POOR QUALITY

Table 6. One-Third Octave Band Sound Pressure Levels Exterior To the Payload Bay During STS-2 Lift-Off

Freq. (Hz)	One-Third Octave Band Sound Pressure Level, dB (ref: 20 µPa)												
	202	204	206	207	210	402	404	686	687	689	692	734	735
12	119.0*	132.0	130.0	128.0	130.0	133.0	139.5	137.5	136.6	139.0	111.8*	132.8	135.7
16	115.3*	133.0	132.0	130.0	132.5	137.0	137.0	140.0	139.0	137.0	116.0	136.0	136.8
20	116.7*	133.0	134.5	133.0	134.0	133.0	136.0	142.0	138.5	138.2	117.5	136.0	137.7
25	124.0	134.5	137.0	136.0	134.0	133.0	137.5	144.0	137.5	141.0	125.0	134.0	136.0
31.5	132.7	135.0	133.0	135.0	133.0	135.0	140.0	145.5	137.5	141.0	119.0	136.0	137.8
40	137.2	136.0	139.0	136.0	134.5	137.0	140.7	148.0	137.0	141.0	122.0	139.0	138.5
50	125.5	136.0	139.0	135.0	136.5	138.0	141.0	146.0	140.0	140.0	125.0	139.2	144.0
63	129.0	137.0	139.0	135.0	140.0	138.0	141.0	143.0	140.0	137.5	123.0	142.0	140.0
80	126.0	138.5	139.0	135.0	140.0	138.0	143.0	147.5	141.0	139.0	120.0	143.0	145.0
100	120.7*	139.0	138.0	134.0	140.0	138.0	145.0	144.5	144.0	142.0	119.5	142.5	145.0
125	120.3*	140.0	138.0	133.0	141.0	140.0	145.0	147.0	144.0	145.0	122.0	146.0	145.0
160	116.3*	137.5	137.0	132.0	141.0	140.0	145.0	149.0	145.2	148.0	122.5	145.0	145.0
200	114.8*	138.5	138.0	136.0	140.0	142.0	147.0	145.5	144.8	148.0	123.0	147.0	146.5
250	114.8*	139.0	138.0	137.0	141.5	141.0	145.0	148.0	144.0	148.0	119.5	147.0	146.5
315	**	137.0	140.0	136.5	141.0	139.0	141.5	149.0	145.0	149.0	118.7	147.0	146.5
400	**	137.0	139.0	137.0	141.0	139.0	141.5	149.0	144.0	150.0	117.0	147.3	145.0
500	**	136.0	139.0	137.0	140.0	138.5	143.5	147.5	144.0	151.0	119.0	146.0	145.0
630	**	136.0	138.0	136.0	139.0	138.0	142.0	147.0	143.0	150.0	120.0	145.0	145.0
800	**	134.0	135.5	133.5	135.0	136.0	142.5	149.0	143.0	150.5	120.0	145.0	144.0
1000	**	117.4*	135.0	135.5	134.0	136.0	143.0	150.5	141.0	150.0	118.5	144.5	143.0
1250	120.3*	133.0	135.0	133.0	138.0	135.0	142.5	150.5	140.5	150.0	118.5	143.5	142.0
1600	120.8*	132.0	135.0	133.5	137.0	133.0	141.0	151.0	140.0	149.0	119.5	142.0	140.5
2000	121.4*	131.0	132.2*	133.0	136.0	133.0	139.5	152.0	139.8	149.0	123.0	142.0	140.5
2500	123.4*	131.0	133.0*	133.0	135.0	132.5	137.5	152.0	138.3	149.5	120.0*	142.0	141.0
3150	123.4*	131.0	**	132.5	135.0	132.4*	138.0	155.5	138.0	150.0	120.7*	142.0	138.5
4000	125.8*	131.0	**	134.0	135.0	133.0*	137.5	158.0	136.0	152.5	122.4*	142.0	138.0

\*Corrected for background noise  
\*\*Background noise too large for correction

ORIGINAL FACILITY  
OF POOR QUALITY

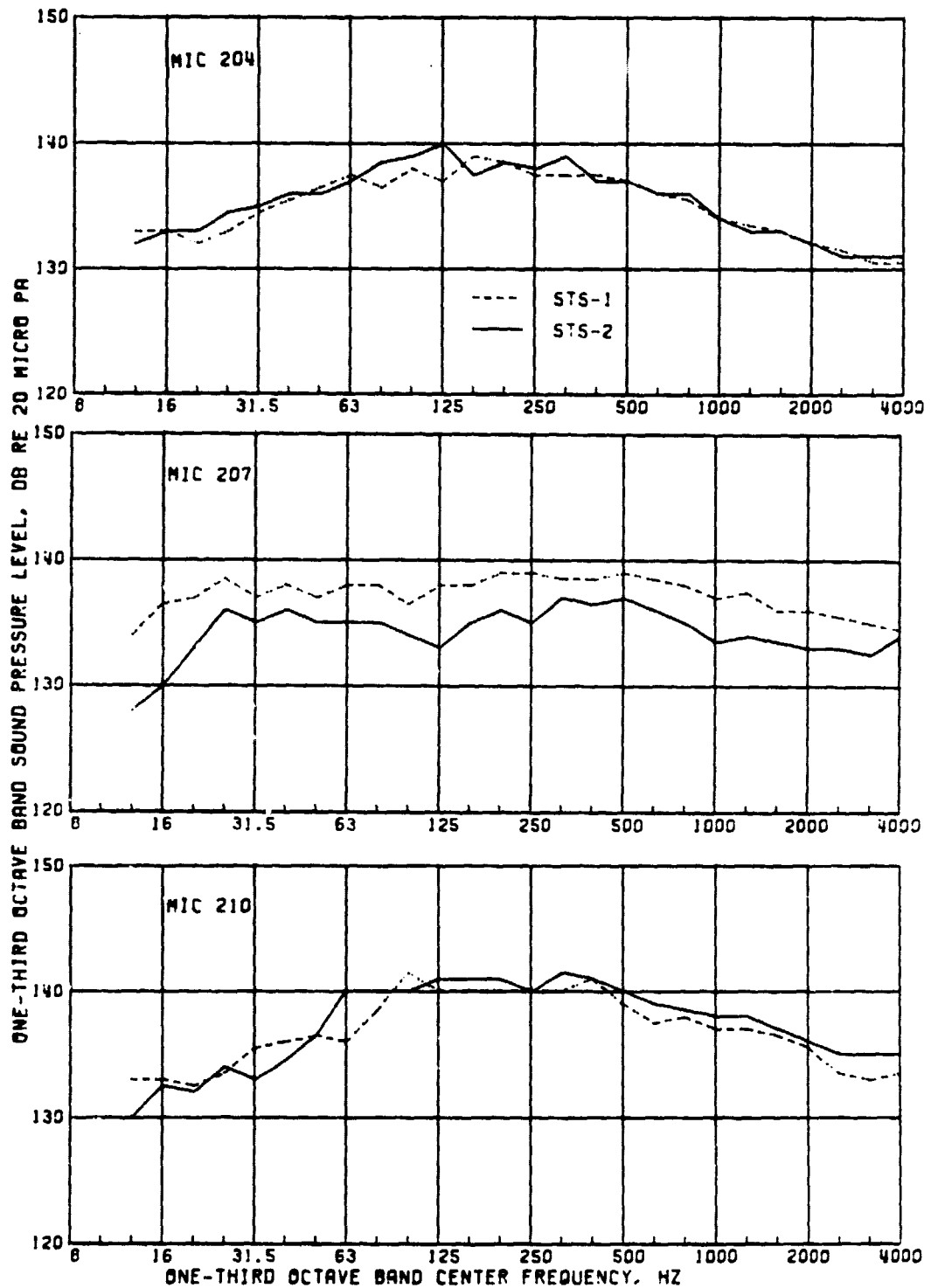

FIGURE 10. ONE-THIRD OCTAVE BAND SOUND PRESSURE LEVELS AT EXTERIOR LOCATIONS DURING STS-1 AND STS-2

ORIGINAL FILED IN  
OF POOR QUALITY

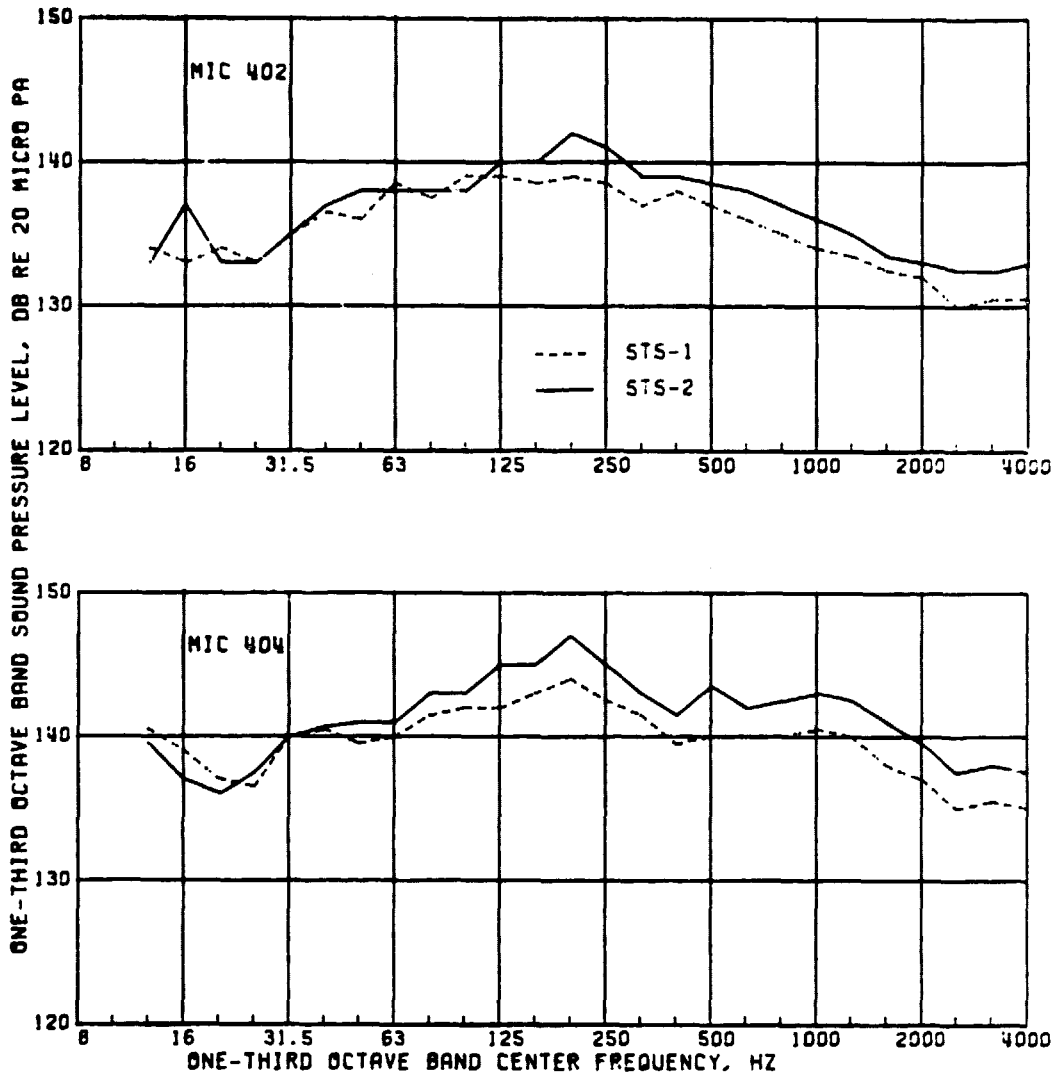

FIGURE 10. CONTINUED

ORIGINAL PAGE IS  
OF POOR QUALITY

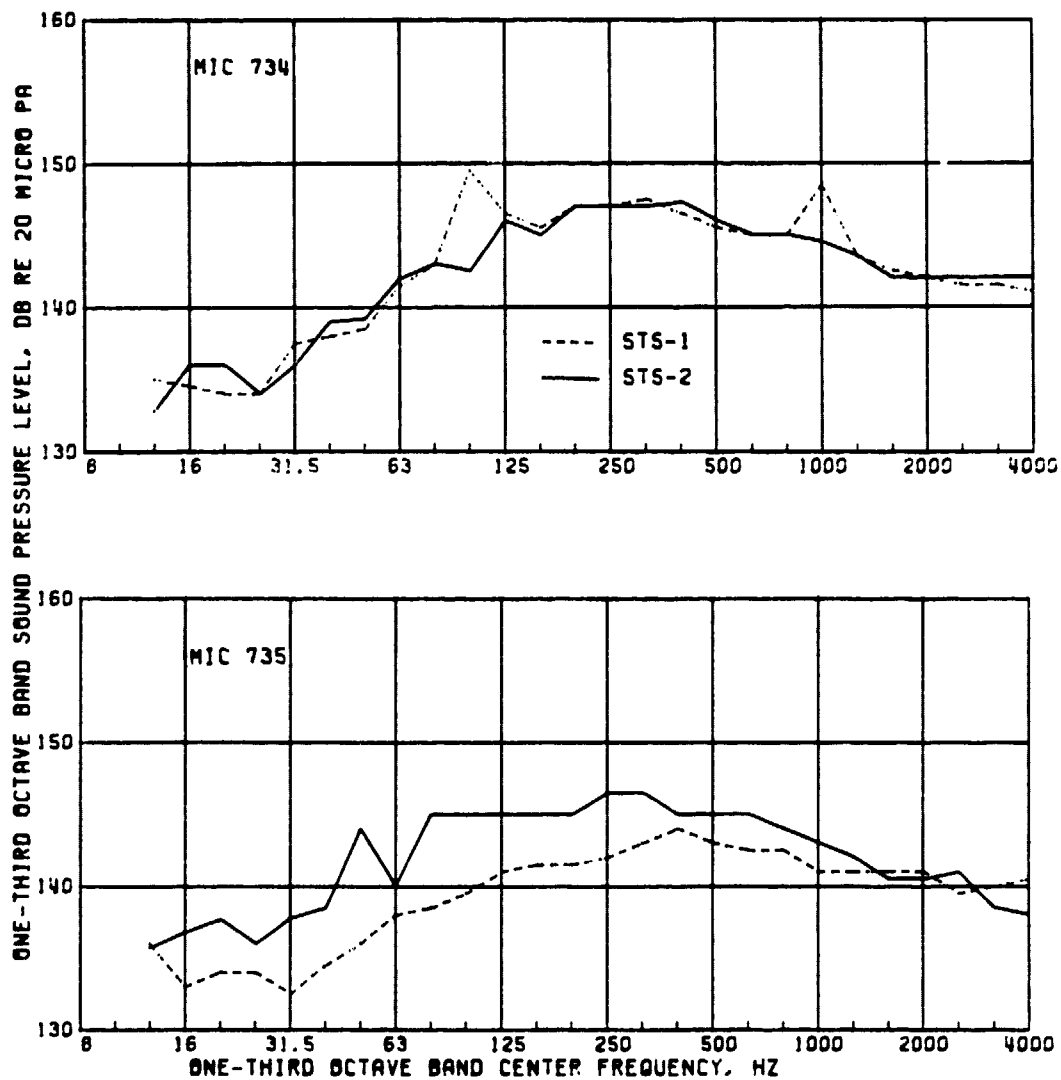

FIGURE 10. CONTINUED

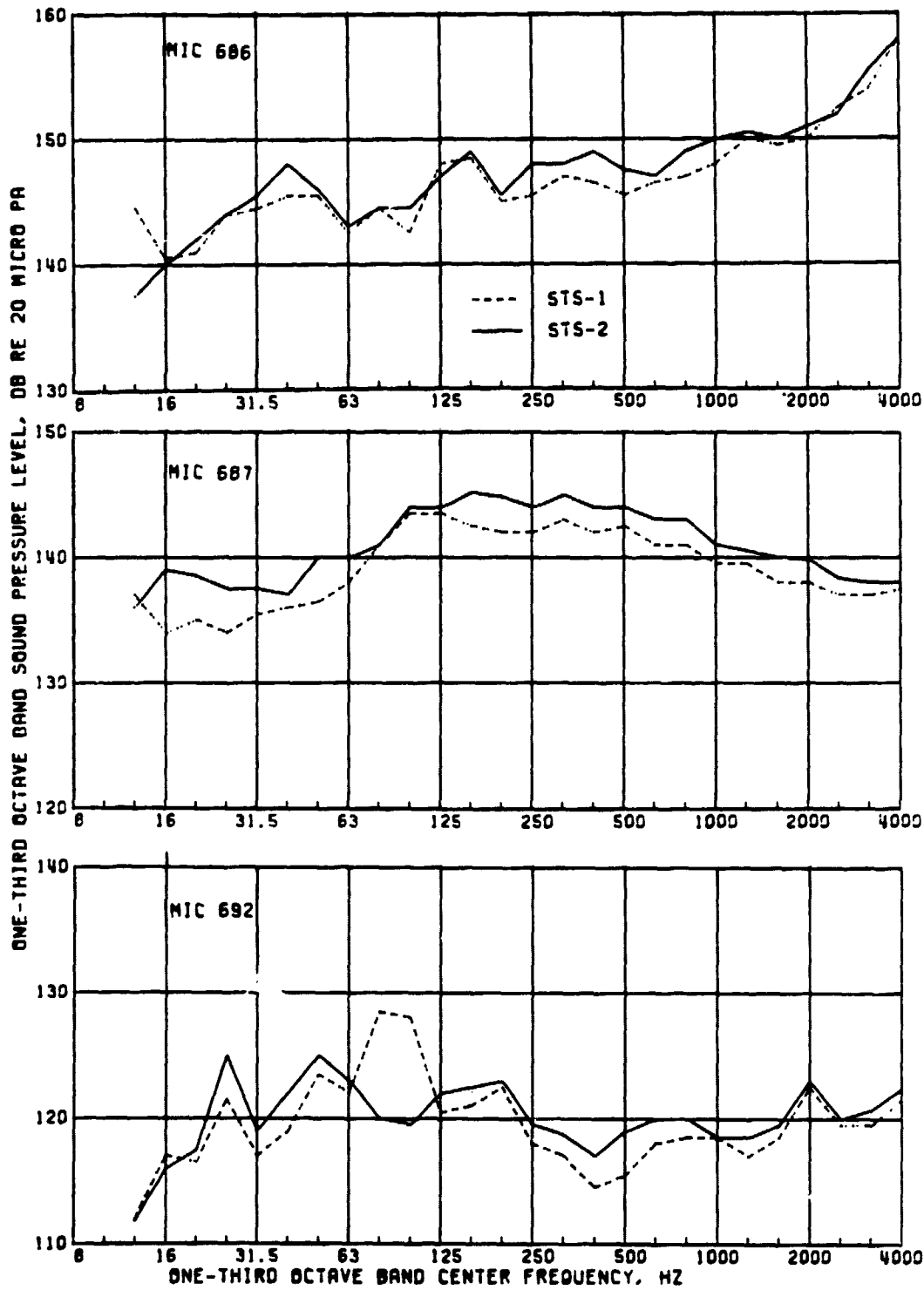

FIGURE 10. CONTINUED

indicates the levels at this location during STS-2 were substantially higher (by 3 to 7 dB) than the STS-1 levels in the frequency range below 1000 Hz.

As noted previously in Section 3, one critical microphone on the aft fuselage sidewall which had functioned properly during STS-1 (microphone 681 in [3]) malfunctioned during STS-2. In order to compensate for this lack of information, the average values of the difference between the STS-2 and STS-1 measurements were calculated for the aft microphones (402, 686 and 687) above the wing. These average differences were then applied to the STS-1 measurement at microphone 681, as shown in Table 7, to give an estimated spectrum (Figure 11) at microphone 681 during STS-2.

### 5.3 Estimation of Space-Average Sound Levels

The objective of the evaluation of the measured exterior sound levels is to generate data input information for use in the computation of payload bay sound levels using the PACES computer program. The exterior structure of the payload bay of the orbiter vehicle is modeled as six regions in PACES. These regions are:

- |                                       |                  |
|---------------------------------------|------------------|
| (1) Payload bay doors                 | Sta 582 to 1307  |
| (2) Bottom structure (forward region) | Sta 582 to 1191  |
| (3) Bottom structure (aft region)     | Sta 1191 to 1307 |
| (4) Sidewall (forward region)         | Sta 582 to 1040  |
| (5) Sidewall (aft region)             | Sta 1040 to 1307 |
| (6) Aft bulkhead                      | Sta 1307         |

(It is assumed that there is no acoustic power flow through the forward bulkhead of the payload bay). The analytical model for PACES requires that a space-average sound pressure level spectrum, in one-third octave frequency bands, be provided for each region. These spectra are used as data inputs to the computer program. The evaluation of the STS-2 exterior sound levels has

Table 7. One-Third Octave Band Sound Pressure  
Levels at Exterior Microphone 681

Freq. Hz.	SPL <sub>STS-2</sub> -SPL <sub>STS-1</sub>			Estimated Difference 681	SPL at Microphone 681 dB re 20 $\mu$ Pa	
	Microphone Number 402	686	687		STS-1	STS-2
12	-1.0	-7.0	-1.0	-3.0	138.0	135.0
16	4.0	-.5	5.0	2.8	136.5	139.3
20	-1.0	1.0	3.5	1.2	137.5	138.7
25	0.0	0.0	3.5	1.2	136.5	137.7
31.5	0.0	1.0	2.0	1.0	137.5	138.5
40	.5	2.5	1.0	1.3	138.0	139.3
50	2.0	.5	3.5	2.0	141.0	143.0
63	-.5	.5	2.0	.7	141.5	142.2
80	.5	0.0	0.0	.2	144.0	144.2
100	-1.0	2.0	.5	.5	143.0	143.5
125	1.0	-1.0	.5	.2	144.5	144.7
160	1.5	.5	2.7	1.6	147.0	148.6
200	3.0	.5	2.8	2.1	148.5	150.6
250	2.5	2.5	2.0	2.3	146.5	148.8
315	2.0	1.0	2.0	1.7	147.0	148.7
400	1.0	2.5	2.0	1.8	146.5	148.3
500	1.5	2.0	1.5	1.7	146.5	148.2
630	2.0	.5	2.0	1.5	145.5	147.0
800	2.0	2.0	2.0	2.0	144.0	146.0
1000	2.0	2.0	1.5	1.8	143.5	145.3
1250	1.5	.5	1.0	1.0	143.0	144.0
1600	1.0	.5	2.0	1.2	140.5	141.7
2000	1.0	1.0	1.8	1.3	141.5	142.8
2500	2.5	-.5	1.3	1.1	143.0	144.1
3150	1.9	1.5	1.0	1.5	144.5	146.0
4000	2.5	0.0	.5	1.0	144.0	145.0



ORIGINAL PAGES 13  
OF POOR QUALITY

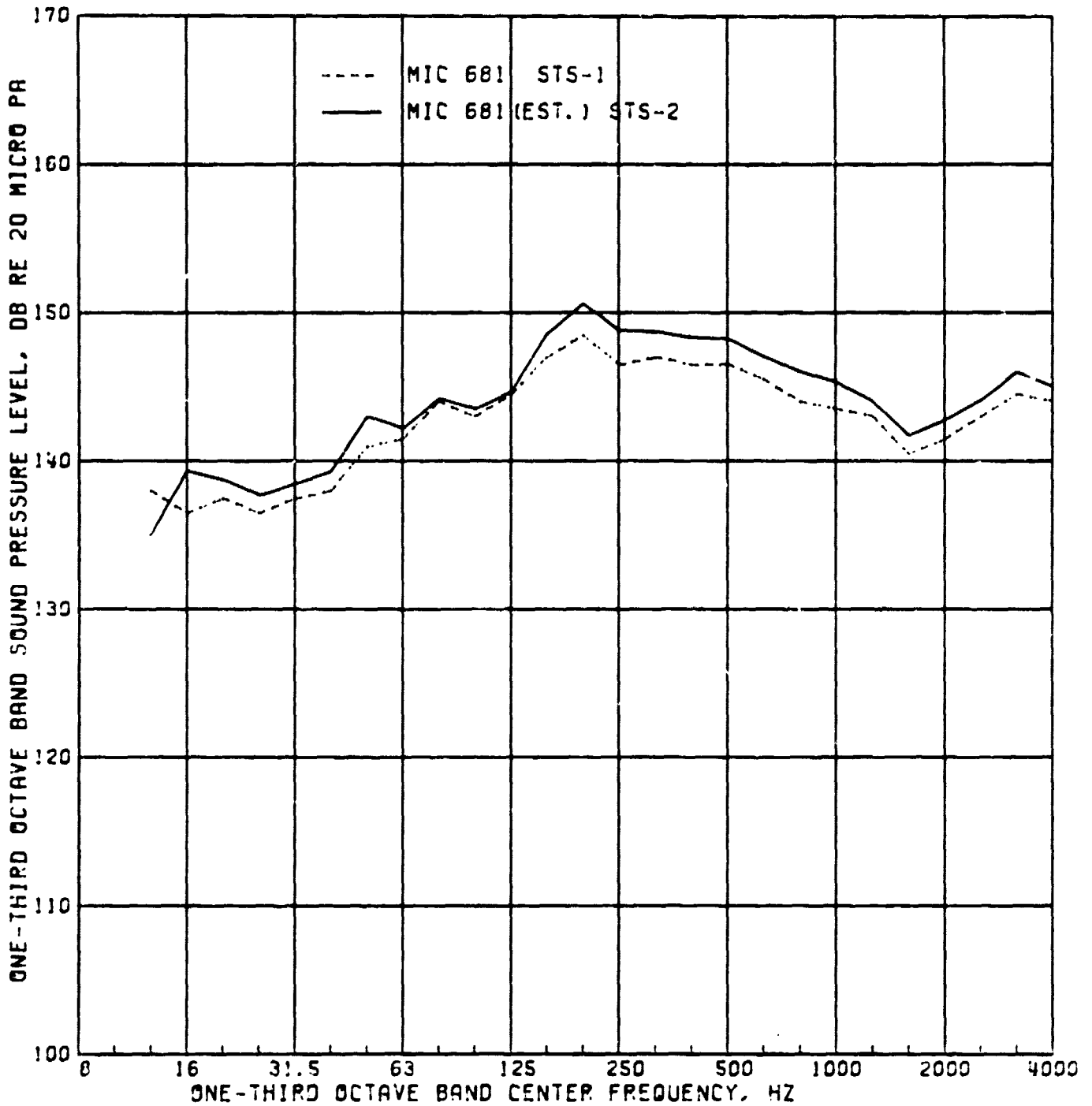

FIGURE 11. ESTIMATED ONE-THIRD OCTAVE BAND SOUND PRESSURE LEVELS AT MICROPHONE LOCATION 681 DURING STS-2

to be performed in order to determine estimates for these six spectra. The approaches used in determining these spectra are described briefly in the following discussion.

#### **Payload Bay Door:**

Data are available for microphone locations 402 (Microphone No. V08Y9402A at X = 1300) at the aft end of the payload bay door and 204 (Microphone No. V08Y9204A at X = 520) on the top of the forward fuselage just forward of the payload bay. A comparison of the one-third octave band levels shows that the values are very similar for the two locations, as is shown in Figure 12. Thus, space-average sound levels were computed by taking the energy average of the sound levels at the two locations.

This approach makes two assumptions. Firstly, it is assumed that the similarity of the sound levels at locations 204 and 402 implies that there is no significant variation in sound level along the length of the door. Secondly, it is assumed that the sound levels along the door centerline are typical of the levels in the circumferential direction. The only information regarding the circumferential distribution of sound levels on the door is provided by location 210 (Microphone No. V08Y9210A at X = 540, Z = 420). This location is on the side of the forward fuselage, at approximately the same longitudinal station as location 204. The sound levels at 210 are similar to those at 204, for frequencies below 100 Hz, but at higher frequencies the sound levels are 2 to 5 dB higher than those at 204 (see Figure 10). However, if data for locations 204 and 210 were energy-averaged to obtain an estimate of the sound levels at the forward end of the door, the net effect on the door space-average sound level would be 1.5 dB at the most. Furthermore, the coordinate for location 210 corresponds roughly to the hinge line of the payload bay door and to a region of the door which is highly-curved and, thus, stiff.

ORIGINAL COPY  
OF POOR QUALITY

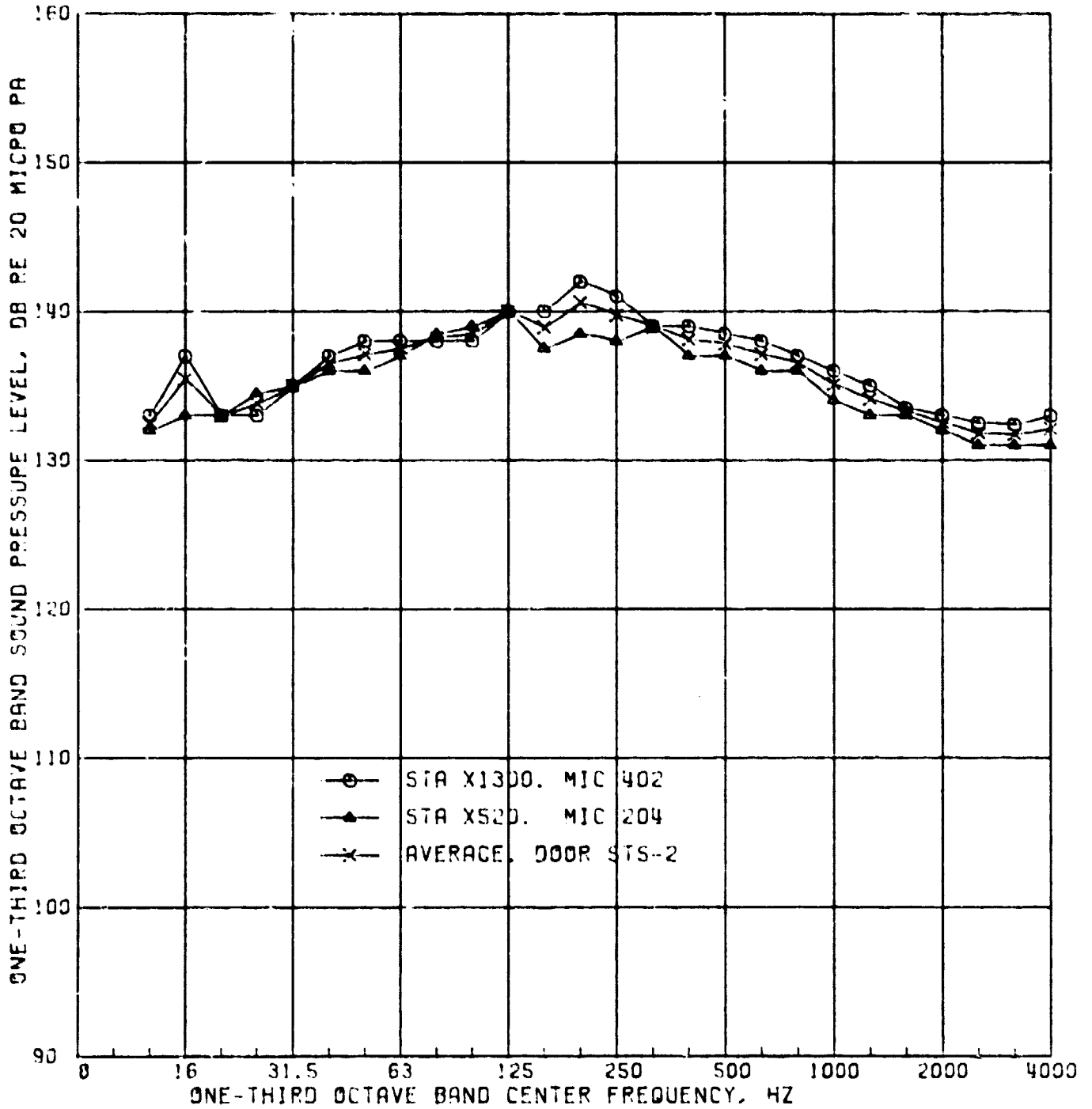

FIGURE 12. SOUND LEVELS ON PAYLOAD BAY DOOR (STS-2)

Consequently the higher sound levels measured at location 210 will probably have a negligible effect on the acoustic power transmitted through the door, and the data were not included in the computation of the space-average sound levels on the door.

Figure 13 shows the comparison between the space-average sound levels for STS-1 and STS-2, with the STS-2 levels 1-2 dB higher at frequencies above 100 Hz.

#### **Sidewall:**

Data are available only for microphone location 210 (Microphone No. V08Y9210A at  $X = 540$ ) on the forward fuselage, as a malfunction of microphone 681 (Microphone No. V08Y9681A at  $X = 1420$ ) occurred. An estimate was made of the level at microphone 681 from the STS-1 spectrum (see Table 7). There was no microphone location on the sidewall of the mid-fuselage. Consequently, some method has to be devised to interpolate between the two measurement locations.

As can be seen in Figure 14, the sound levels at the two locations differed by up to 11 dB, in contrast to the sound levels at the forward and aft ends of the door where the levels were within 3 dB. Furthermore, it is required to obtain space-average sound levels for two different areas on the sidewall. It is thus not possible simply to take the energy average of the sound levels at the two measurement locations. Two alternative approaches were tried. In the first approach it was assumed that the mean square pressure varied inversely with the square of the distance from the source (i.e. free field of a point source) and in the second method the mean square pressure was assumed to vary inversely with distance (i.e. a line source). The inverse square law was finally adopted because the effective source locations were more acceptable from physical considerations. At low frequencies the effective source

ORIGINAL PAGE IS  
OF POOR QUALITY

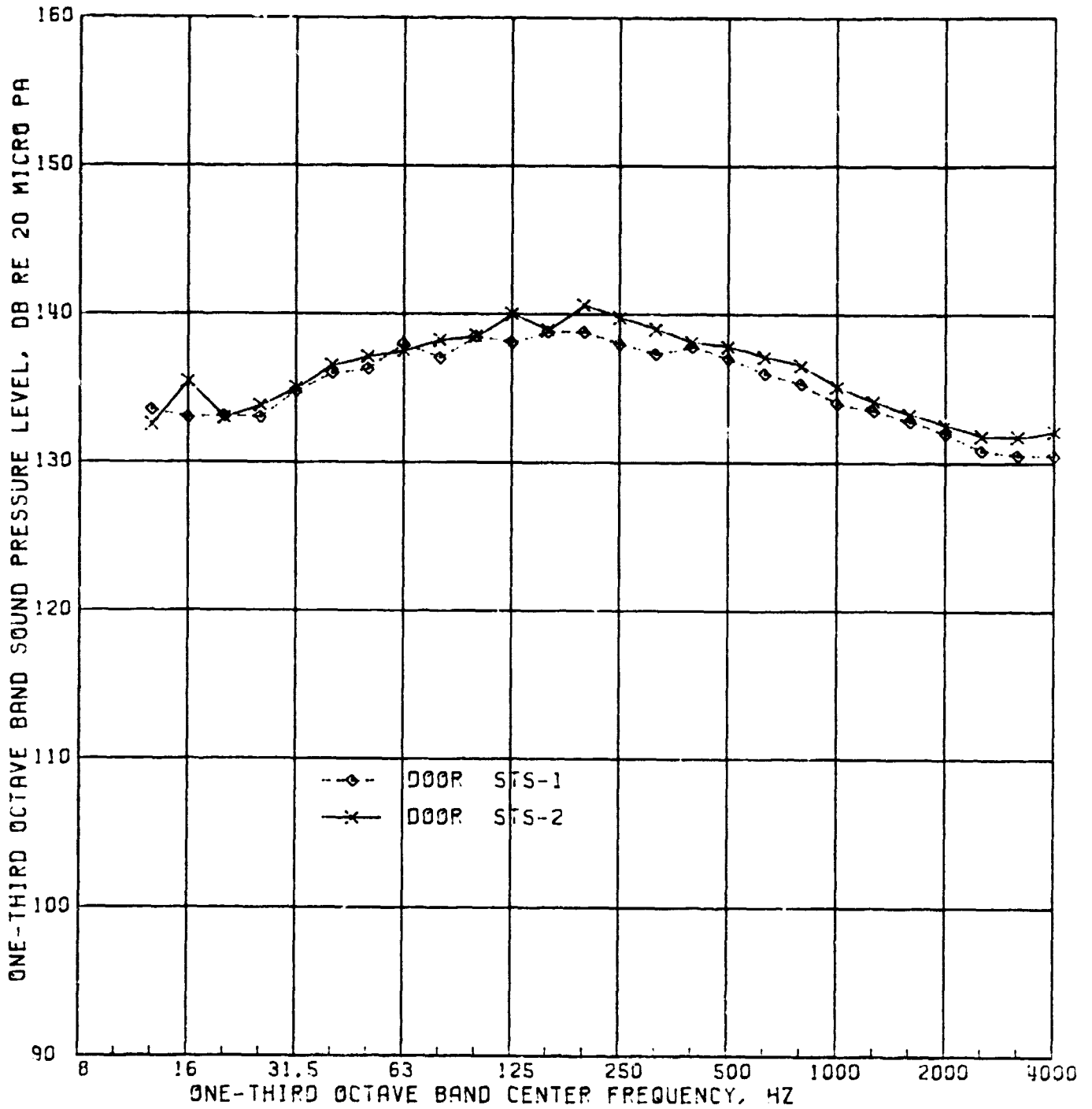

FIGURE 13. COMPARISON OF SPACE-AVERAGE SOUND LEVELS ON PAYLOAD BAY DOOR (STS-1 AND STS-2)

ORIGINAL PAGE IS  
OF POOR QUALITY

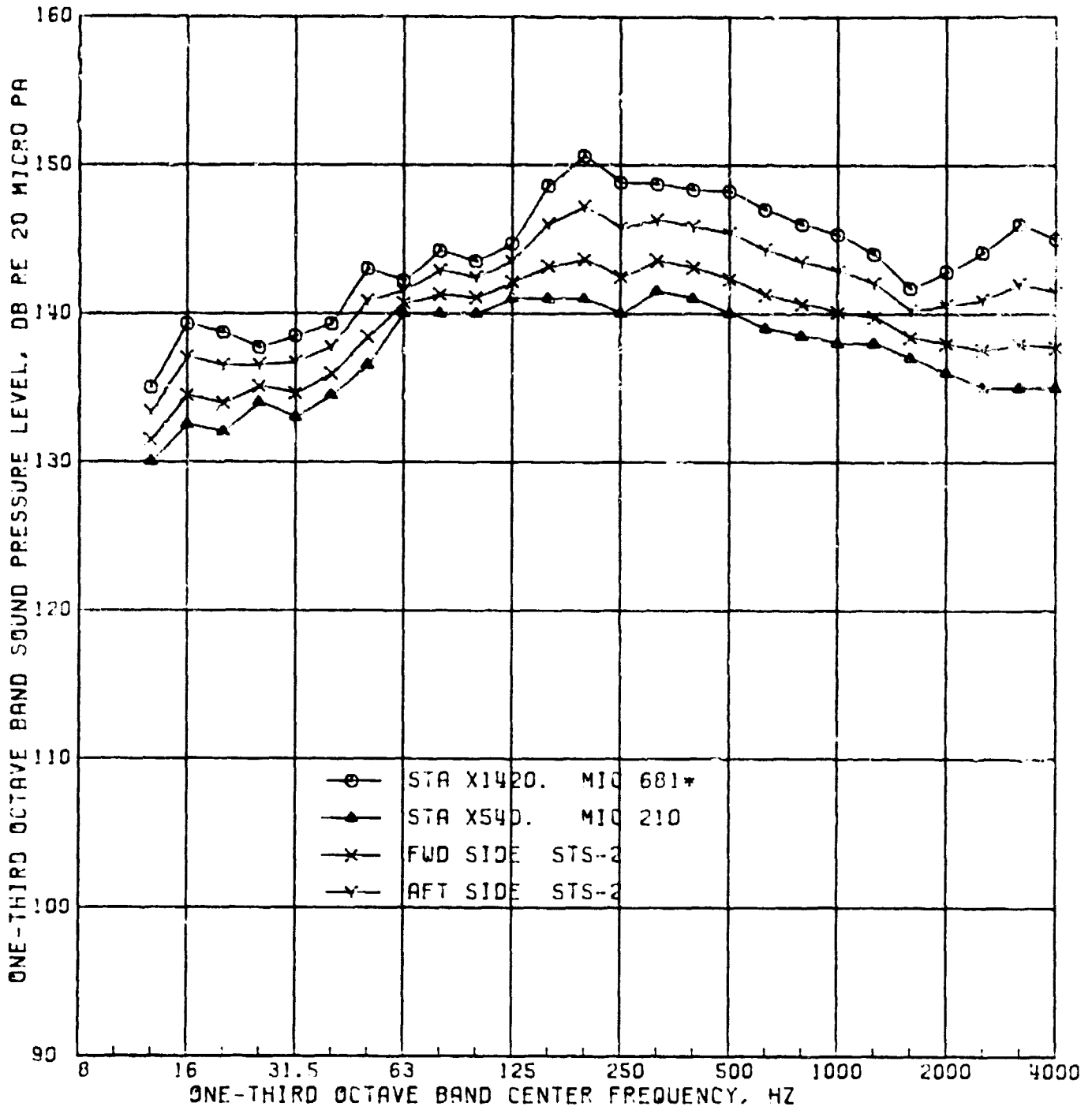

FIGURE 14. SOUND LEVELS ON MID-FUSELAGE SIDEWALL (STS-2)

locations were 60 to 150 feet aft of the orbiter vehicle and at high frequencies, 25 to 50 feet.

Applying the inverse square law to the sound levels at  $X = 540$  and  $1420$ , an effective source location was determined at each one-third octave band center frequency. The inverse square law was then used to estimate sound levels at the forward ( $X = 582$ ) and aft ( $X = 1307$ ) ends of the sidewall, and at  $X = 1040$ , the boundary between the forward and aft regions of the sidewall. Finally, the sound levels at  $X = 582$  and  $X = 1040$  were averaged on an energy basis to obtain space-average levels for the forward region, and a similar process was applied to sound levels at  $X = 1040$  and  $1370$  for the aft region.

The estimated space-average sound levels for the forward and aft regions of the sidewall are plotted in Figure 14, and the levels are compared in Figure 15 with corresponding spectra predicted for STS-1. The STS-2 data are similar to the STS-1 data below 160 Hz, but are approximately 1 dB greater at higher frequencies, for both forward and aft regions. The assumptions implicit in the estimation of space-average sound levels on the sidewall for STS-2 are the same as those for the door. These assumptions are (a) that the sound level varies monotonically in the longitudinal direction and (b) the sound level is essentially constant in the lateral direction. The same assumptions will also be adopted for the bottom structure.

#### **Bottom Structure:**

Data are available for microphone locations 404 (Microphone No. V08Y9404A at  $X = 1300$ ) on the aft region of the mid-fuselage bottom structure, 689 (Microphone No. V08Y9689A at  $X = 1400$ ) on the aft fuselage bottom structure, and 206 (Microphone No. V08Y9206A at  $X = 385$ ) and 207 (Microphone No. V08Y9207A at  $X = 500$ ) on the bottom structure of the forward fuselage. No microphone was located on the forward region of the mid-fuselage

ORIGINAL PAGE IS  
OF POOR QUALITY

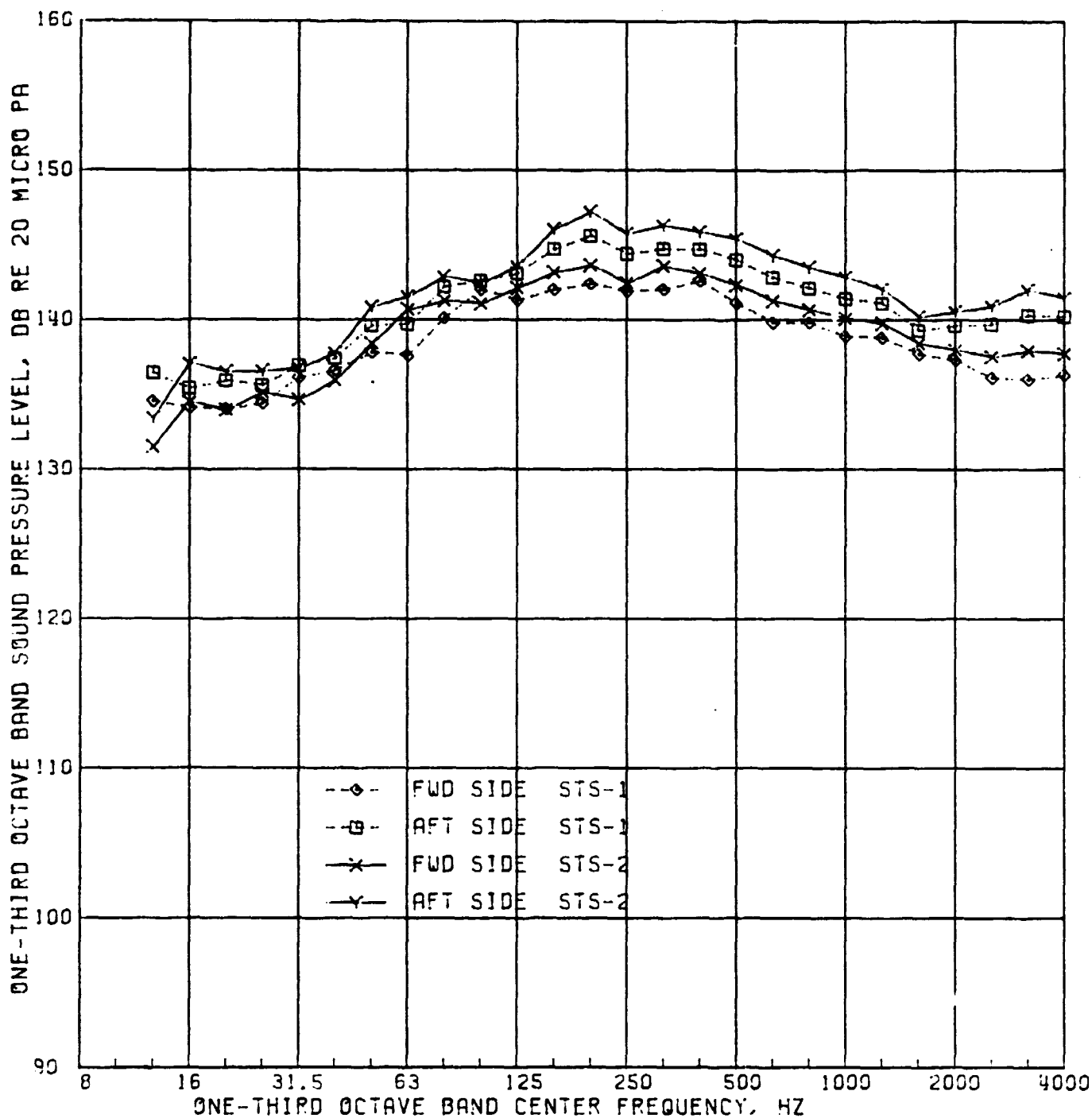

FIGURE 15. COMPARISON OF SPACE-AVERAGE SOUND LEVELS ON MID-FUSELAGE SIDEWALL (STS-1 AND STS-2)



bottom structure. Consequently, it was again necessary to apply an interpolation procedure, and, for consistency, the inverse square law adopted for the sidewall was again used.

Sound levels at the four locations are shown in Figure 16. Microphone 689 has a noticeably different spectrum shape at high frequencies and hence was not used for the interpolation procedure. Using microphones 207 and 404, the same interpolation and averaging procedure was performed as for the sidewall. The estimated space-average levels for the forward and aft regions are shown in Figure 17, and are seen to be strongly influenced by the high levels at Station 404. However, the levels at microphone 207 are not only consistently lower (by 3 to 5 dB) than the STS-1 levels, but are also lower than microphone 206 STS-2 levels. To check the effect of this, levels at microphones 206 and 207 were averaged before the interpolation procedure was carried out. The estimated levels for the forward bottom increased by 1 dB or less and those for the aft bottom were unchanged.

The estimated levels using microphones 207 and 404 only were therefore used, as for the STS-1 data. Figure 18 compares the estimated space-average levels for the bottom for STS-1 and STS-2. The levels for the aft bottom are typically 2.5 dB higher for the STS-2 at frequencies above 100 Hz.

#### **Bulkhead:**

Sound levels in the aft fuselage were measured at only one location, 692 (Microphone No. V08Y969A) shown in Figure 4. In the absence of any other information, it is therefore assumed that the sound levels measured at that location are representative of the space-average values on the aft bulkhead of the payload bay. The sound pressure level spectra measured at

ORIGINAL FILED IN  
OF POOR QUALITY

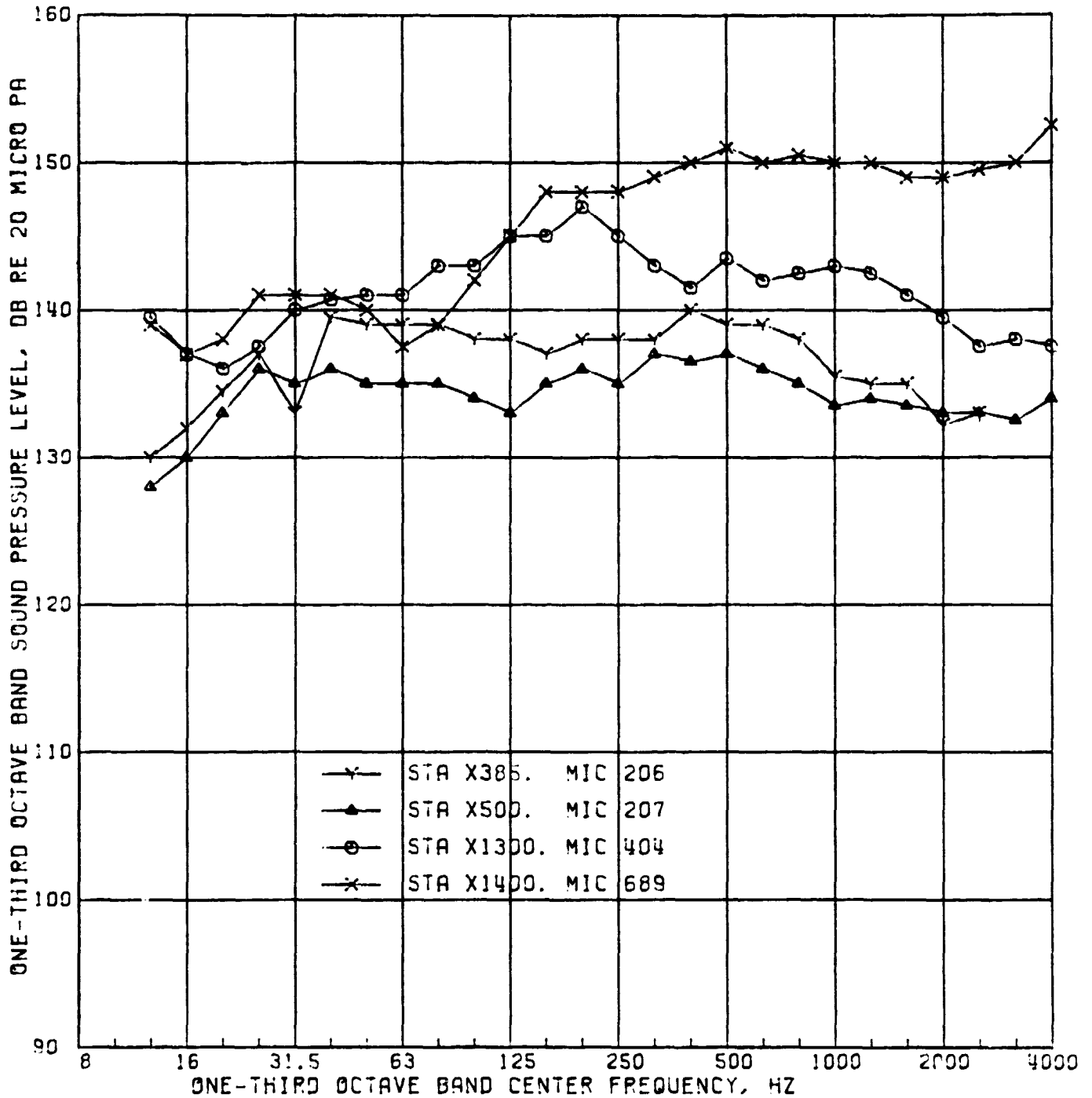

FIGURE 16. SOUND LEVELS ON MID-FUSELAGE BOTTOM STRUCTURE (STS-2)

ORIGINAL PAGE IS  
OF POOR QUALITY

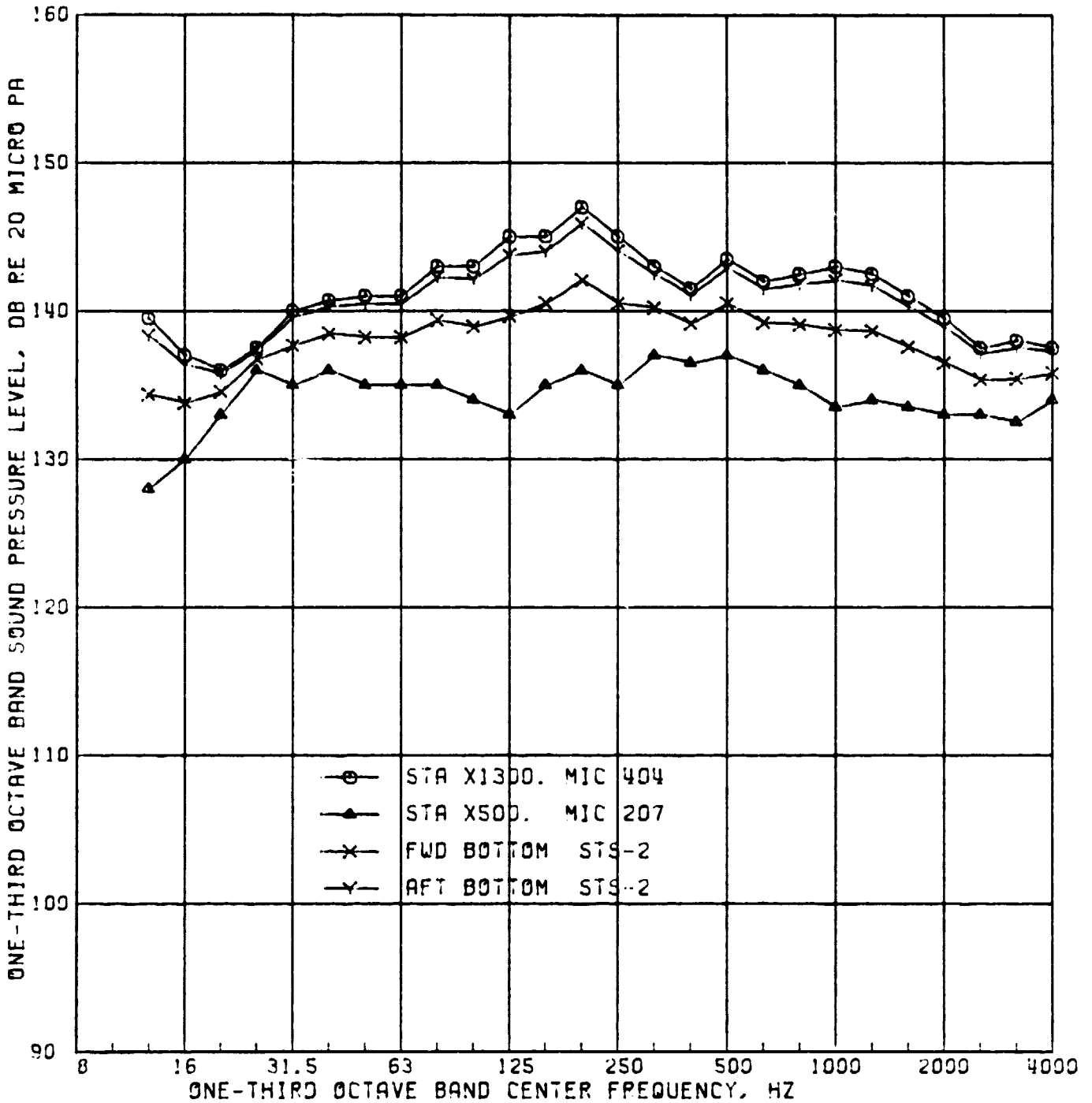

FIGURE 17. SOUND LEVELS ON MID-FUSELAGE BOTTOM STRUCTURE (STS-2)

ORIGINAL PAGE IS  
OF POOR QUALITY

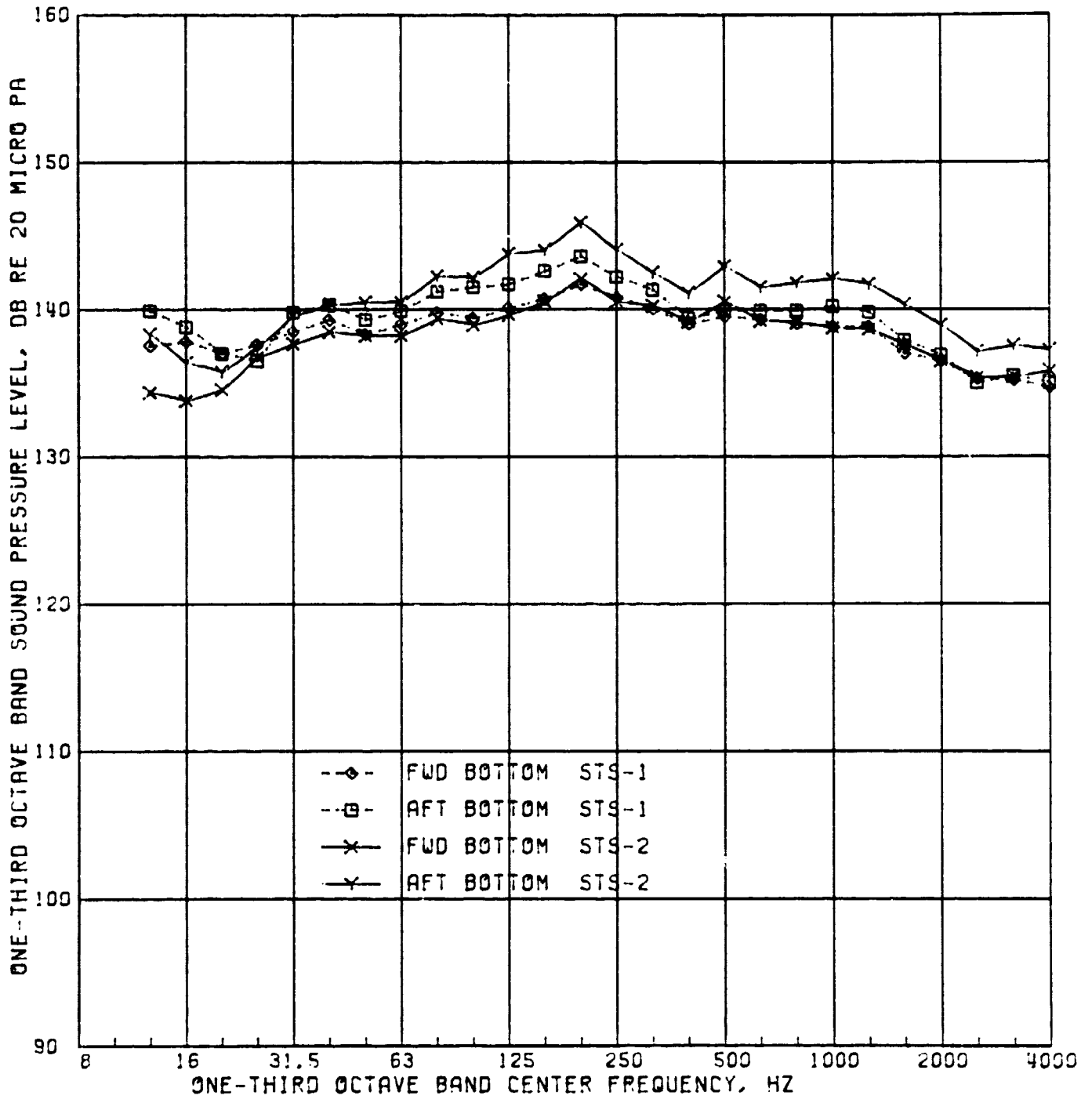

FIGURE 18. SOUND LEVELS ON MID-FUSELAGE BOTTOM STRUCTURE (STS-1 AND STS-2)

location 692 are shown in Figure 19 for both STS-1 and STS-2. The spectra are similar except at 80 Hz and 100 Hz.

#### 5.4 Data Input for PACES

The space-average sound levels calculated for the six structural regions bounding the Space Shuttle payload bay are required as data input for the PACES computer program in order to calculate interior sound levels for STS-2 lift-off. The six one-third octave band spectra, contained in Figures 12 through 19, are collected together in Figure 20 and tabulated in Table 8.

The STS-2 spectra in Figure 20 can be compared with the STS-1 spectra in Figure 21. The STS-2 levels show an increase of 1 to 1.5 dB at frequencies above 100 Hz, but otherwise the levels are similar.

ORIGINAL PAGE IS  
OF POOR QUALITY.

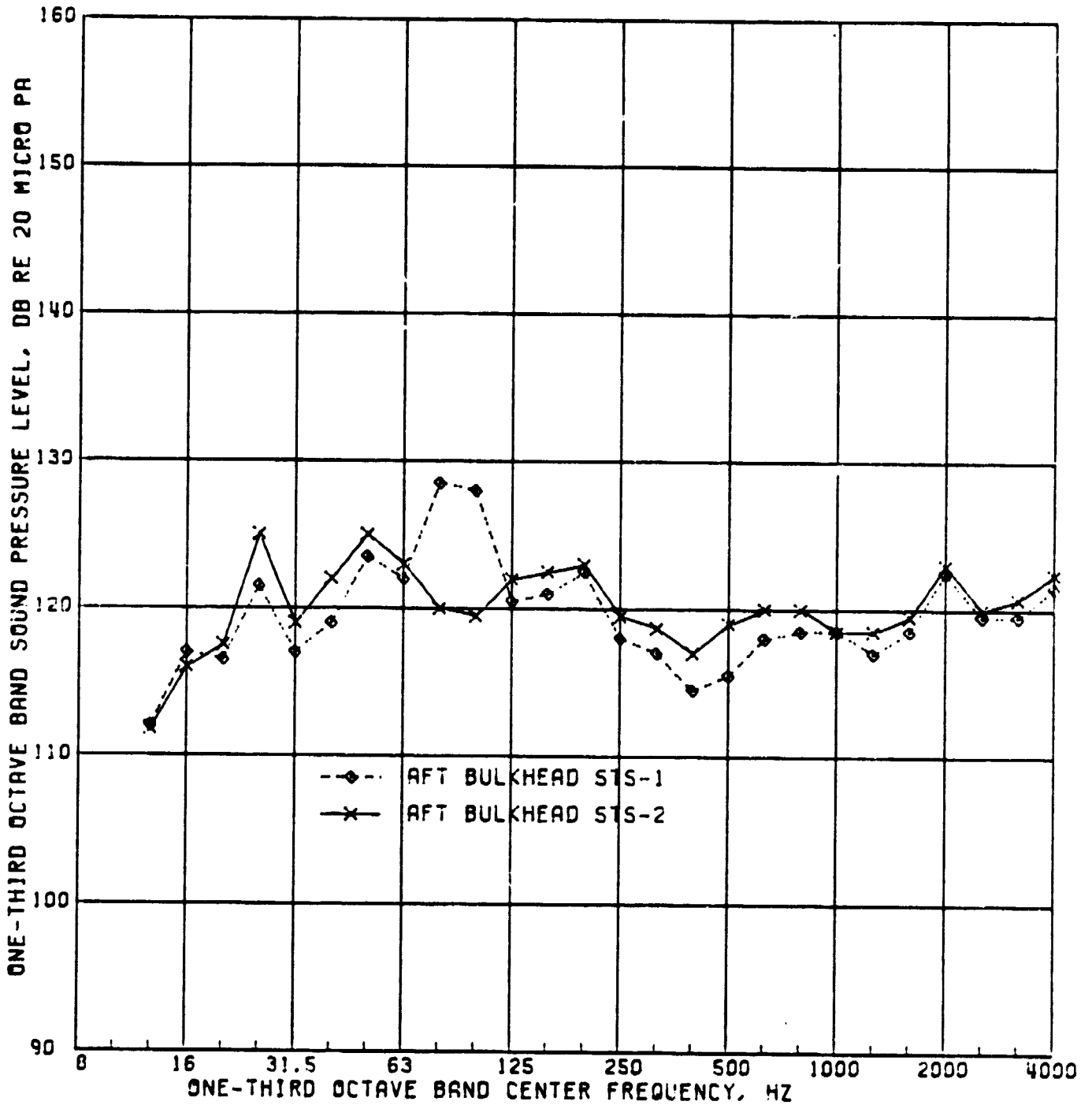

FIGURE 19. SOUND LEVELS ON PAYLOAD BAY AFT BULKHEAD (STS-1 AND STS-2)

ORIGINAL PAGE IS  
OF POOR QUALITY

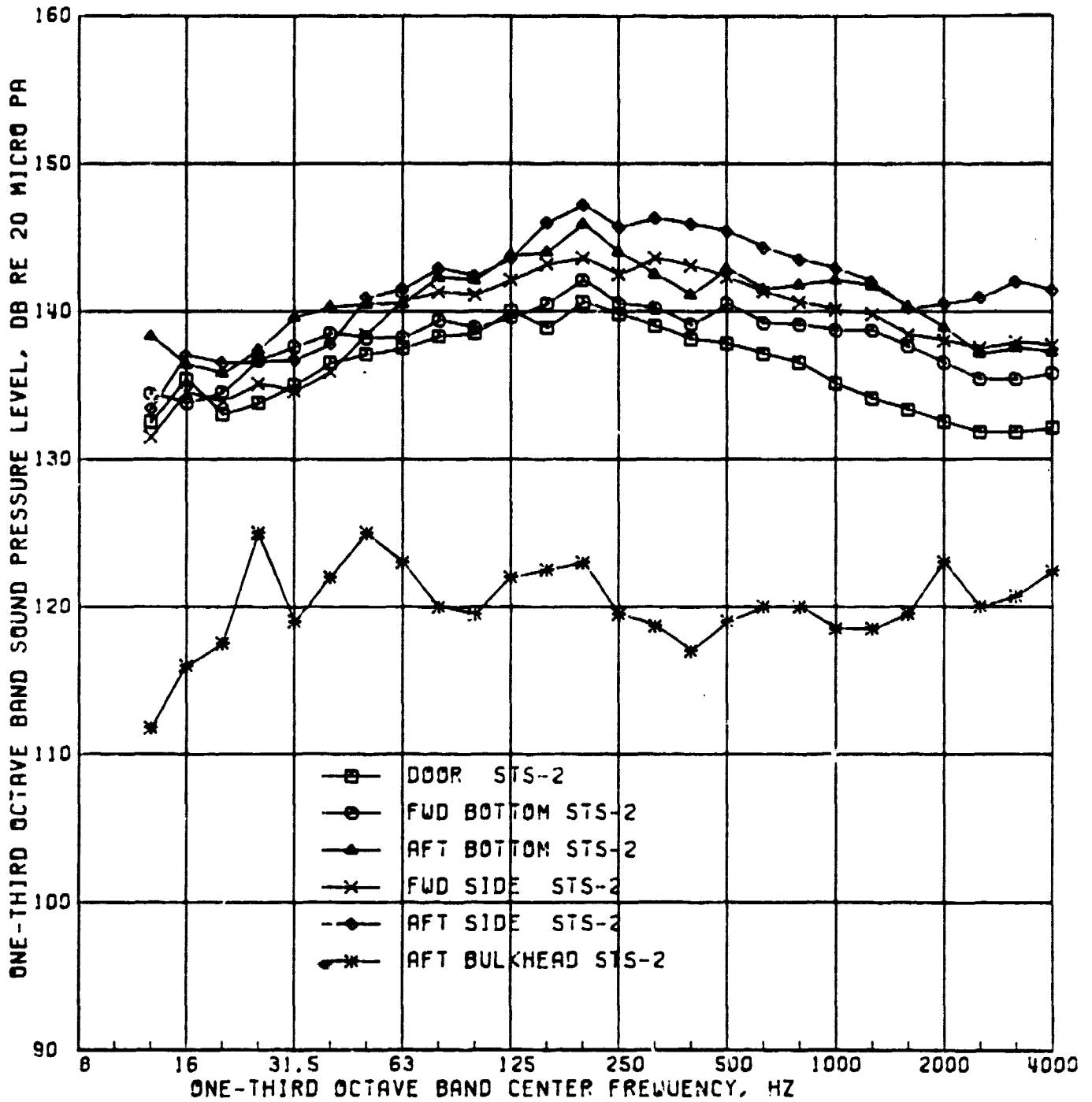

FIGURE 20. SPACE-AVERAGE SOUND LEVELS FOR EXTERIOR OF PAYLOAD BAY ESTIMATED FROM STS-2 DATA

ORIGINAL PAGE IS  
OF POOR QUALITY

Table 8. Exterior Space-Average Sound Pressure  
Levels for STS-2 (dB re 20  $\mu$ Pa)

Frequency Hz	Door	Bottom		Sidewall		Aft Bulkhead
		STA 582 -1191	STA 1191 -1307	STA 582 -1040	STA 1040 -1307	
12.5	132.5	134.4	138.3	131.5	133.4	111.8
16.0	135.4	133.8	136.4	134.5	137.0	116.0
20.0	133.0	134.5	135.8	133.9	136.5	117.5
25.0	133.8	136.7	137.4	135.1	136.6	125.0
31.5	135.0	137.6	139.6	134.6	136.7	119.0
40.0	136.5	138.5	140.3	135.9	137.8	122.0
50.0	137.1	138.2	140.5	138.4	140.9	125.0
63.0	137.5	138.2	140.5	140.7	141.5	123.0
80.0	138.3	139.4	142.3	141.3	142.9	120.0
100.0	138.5	138.9	142.1	141.1	142.4	119.5
125.0	140.0	139.6	143.8	142.1	143.6	122.0
160.0	138.9	140.5	144.0	143.2	146.0	122.5
200.0	140.6	142.1	145.9	143.6	147.2	123.0
250.0	139.8	140.5	144.0	142.5	145.7	119.5
315.0	139.0	140.2	142.5	143.6	146.3	118.7
400.0	138.1	139.1	141.1	143.1	145.9	117.0
500.0	137.8	140.5	142.9	142.3	145.4	119.0
630.0	137.1	139.2	141.5	141.3	144.3	120.0
800.0	136.5	139.1	141.8	140.6	143.5	120.0
1000.0	135.1	138.7	142.1	140.1	142.9	118.5
1250.0	134.1	138.7	141.7	139.8	142.0	118.5
1600.0	133.3	137.6	140.3	138.4	140.2	119.5
2000.0	132.5	136.5	138.9	138.0	140.5	123.0
2500.0	131.8	135.4	137.1	137.5	140.9	120.0
3150.0	131.8	135.4	137.5	137.9	142.0	120.7
4000.0	132.1	135.8	137.2	137.7	141.4	122.4



ORIGINAL PAGES  
OF POOR QUALITY

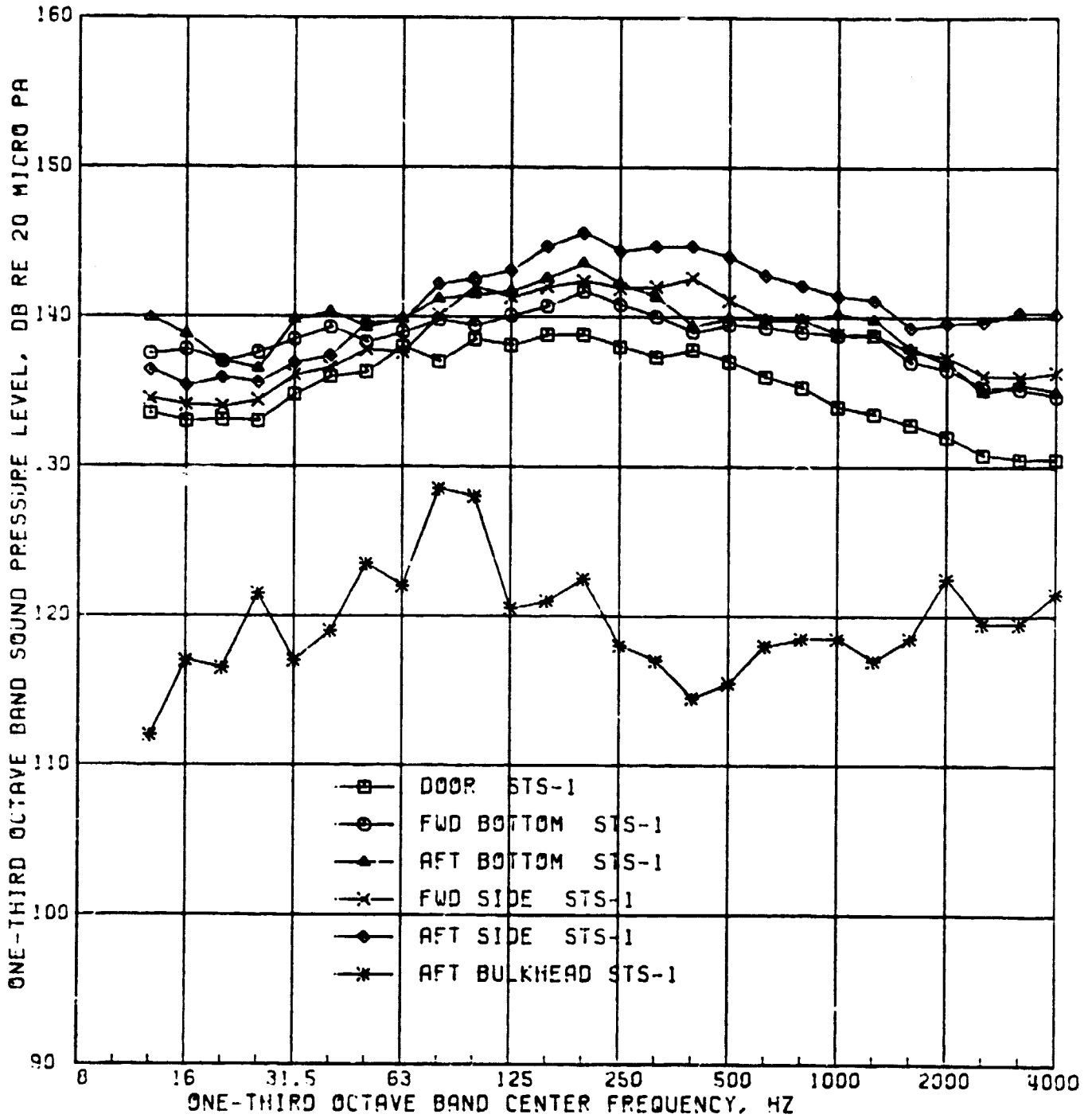

FIGURE 21. SPACE-AVERAGE SOUND LEVELS FOR EXTERIOR OF PAYLOAD BAY ESTIMATED FROM STS-1 DATA

## 6.0 PACES CALCULATIONS

### 6.1 Interior Space-Average Sound Levels

The STS-2 space-average exterior sound levels plotted in Figure 20 have been used as input data to the PACES computer program in order to predict space-average sound pressure levels in the payload bay at lift-off. Three different payload bay configurations have been considered. In the first case the bay was considered to be completely empty. Then, for the second case, the COSTA-1 and DFI payloads were modeled as a single volume-displacing (non-bounding) payload, such as that described in Volume II of [1] for the DSP/IUS payload. Finally, in the third case, the bay was modeled as two subvolumes with the DFI payload forming the bounding surface between the two regions. The COSTA-1 payload was modeled as a volume-displacing payload in the forward subvolume.

These three cases were considered in order to explore the effects of the different idealizations and to provide a reasonable simulation of launch conditions. The results from the analyses are contained in the following three sections.

### 6.2 Empty Bay Representation

In [3] the space-average sound levels in the payload bay for STS-1 were estimated under the assumption that there was no payload in the bay. Thus the DFI payload was assumed to have zero volume and zero sound absorbing area. As the payload size increases from STS-1 to STS-2, the assumption loses its validity. However, for comparison with the STS-1 results, the first prediction for the STS-2 launch assumes again that there is no payload in the bay. Acoustic absorption coefficients for the payload bay surfaces are those given in Table 9, which includes TCS material on the fore and aft bulkheads. The calculated space-average

Table 9. Estimated Absorption Coefficients for Payload Bay

Frequency (Hz)	Door	Bulkhead	Sidewall & Bottom (Base)	Sidewall with TCS		Bottom with TCS		TCS Beneath	Payload
				STA582-919	Average	STA582-919	STA919-1307		
12.5	0.100	0.040	0.040	0.040	0.040	0.040	0.040	0.040	0.175
16		0.043	0.040	0.040	0.054	0.043	0.065	0.054	
20		0.041	0.040	0.090	0.068	0.045	0.068	0.068	
25		0.048	0.040	0.114	0.081	0.048	0.114	0.081	
31.5		0.050	0.040	0.140	0.095	0.050	0.140	0.095	
40		0.055	0.040	0.140	0.098	0.060	0.140	0.100	
50		0.060	0.040	0.145	0.103	0.065	0.145	0.105	
63		0.065	0.040	0.150	0.108	0.075	0.155	0.115	
80		0.075	0.050	0.165	0.120	0.095	0.170	0.133	
100		0.085	0.050	0.180	0.133	0.110	0.195	0.153	
125		0.100	0.050	0.200	0.150	0.125	0.230	0.178	
160		0.105	0.050	0.240	0.173	0.140	0.280	0.210	
200		0.115	0.050	0.280	0.198	0.165	0.375	0.270	
250		0.125	0.050	0.370	0.248	0.220	0.480	0.350	
315		0.210	0.050	0.460	0.335	0.310	0.540	0.425	
400		0.305	0.050	0.505	0.405	0.415	0.565	0.490	
500		0.400	0.050	0.525	0.463	0.480	0.615	0.525	
630		0.400	0.050	0.530	0.465	0.505	0.570	0.538	
800		0.400	0.050	0.530	0.465	0.520	0.570	0.545	
1000		0.400	0.050	0.520	0.460	0.530	0.565	0.548	
1250		0.400	0.050	0.510	0.455	0.535	0.560	0.458	
1600		0.400	0.050	0.505	0.453	0.535	0.550	0.543	
2000		0.400	0.050	0.490	0.445	0.535	0.540	0.538	
2500		0.395	0.050	0.470	0.433	0.525	0.530	0.525	
3150		0.390	0.050	0.455	0.423	0.520	0.520	0.520	
4000		0.390	0.050	0.430	0.410	0.510	0.510	0.510	

ORIGINAL COPY OF POOR QUALITY

interior sound levels for STS-1 and STS-2 launches are compared in Figure 22. Differences in predicted interior levels can be attributed mainly to the changes in the door exterior sound pressure levels shown in Figure 13, since the transmission through the door dominates the predicted spectrum.

### 6.3 Representation with a Single Payload

In this representation the DFI and OSTA-1 payloads are modeled as a single volume-displacing payload with non-bounding surfaces. This is the representation recommended in Volume II of [1] for a payload whose volume is small relative to the volume of the payload bay. This idealization is discussed in Volume II of [1] with reference to the DSP/IUS payload. It is estimated that the total sound-absorbing area of the DFI and OSTA-1 payloads is about 77.4 sq.m (120,000 sq.in) and the total volume is about 21.1 cu.m (1,288,000 cu.in). This volume represents less than 5% of the volume of the total bay.

Absorption coefficients presented in Table 9 for typical payloads were obtained [1] from test data for several shrouded and unshrouded spacecraft. In the particular case of the STS-2 launch, however, it was noted that a large part of the payload area was covered with TCS material. Thus it was consistent to assume that the acoustic absorption properties of the TCS material should be applied to the payload as well as to the payload bay surfaces. Furthermore it was considered reasonable to assume that at low frequencies the absorption coefficients should be typical of relatively flexible spacecraft structures. The resulting composite absorption coefficient spectrum is given in Table 10.

ORIGINAL PAGE IS  
OF POOR QUALITY

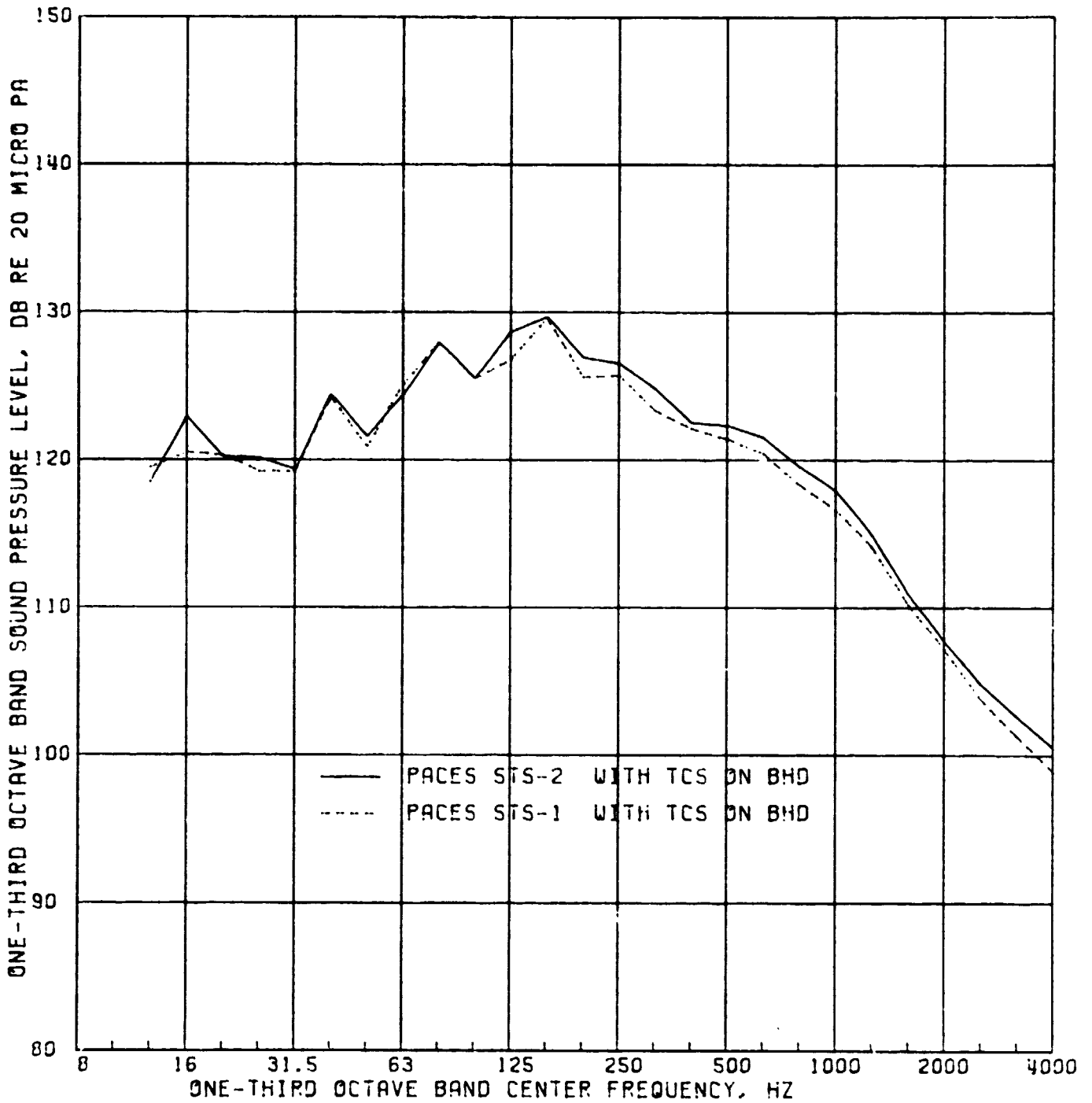

FIGURE 22. PREDICTED SPACE-AVERAGE SOUND PRESSURE LEVELS IN EMPTY PAYLOAD BAY AT LIFT-OFF (STS-1 AND STS-2)

Table 10. Assumed Absorption Coefficients for STS-2 Payload Surfaces

Frequency (Hz)	12.5	16	20	25	31.5	40	50	63	80
Absorp. Coeff.	0.175	0.175	0.175	0.175	0.175	0.175	0.175	0.175	0.175
Frequency (Hz)	100	125	160	200	250	315	400	500	630
Absorp. Coeff.	0.175	0.175	0.175	0.175	0.220	0.310	0.415	0.480	0.505
Frequency (Hz)	800	1000	1250	1600	2000	2500	3150	4000	
Absorp. Coeff.	0.520	0.530	0.535	0.535	0.535	0.525	0.520	0.510	

The inclusion of a volume-displacing payload causes a reduction in the predicted space-average sound pressure levels in the bay of about 1 dB throughout the frequency range of interest. This reduction can be seen in Figure 23 where predicted space-average spectra are compared for the cases of an empty payload bay and a bay with a single volume-displacing payload. The main factor in this noise reduction is the increase in sound absorption within the bay.

#### 6.4 Representation with Two Subvolumes

When payloads have small volumes, the PACES computer program procedure recommends that the payloads be modeled as volume-displacing payloads in a single volume. Such an idealization is discussed in Section 6.3. One important reason for adopting such an idealization is that any arbitrary selected subvolume around a small payload would artificially create acoustic modes which could not occur in practice. These modes distort the PACES predictions. However, it is of interest for STS-2 to assume that the payload bay is divided into two subvolumes, with the DFI

ORIGINAL PAGE IS  
OF POOR QUALITY

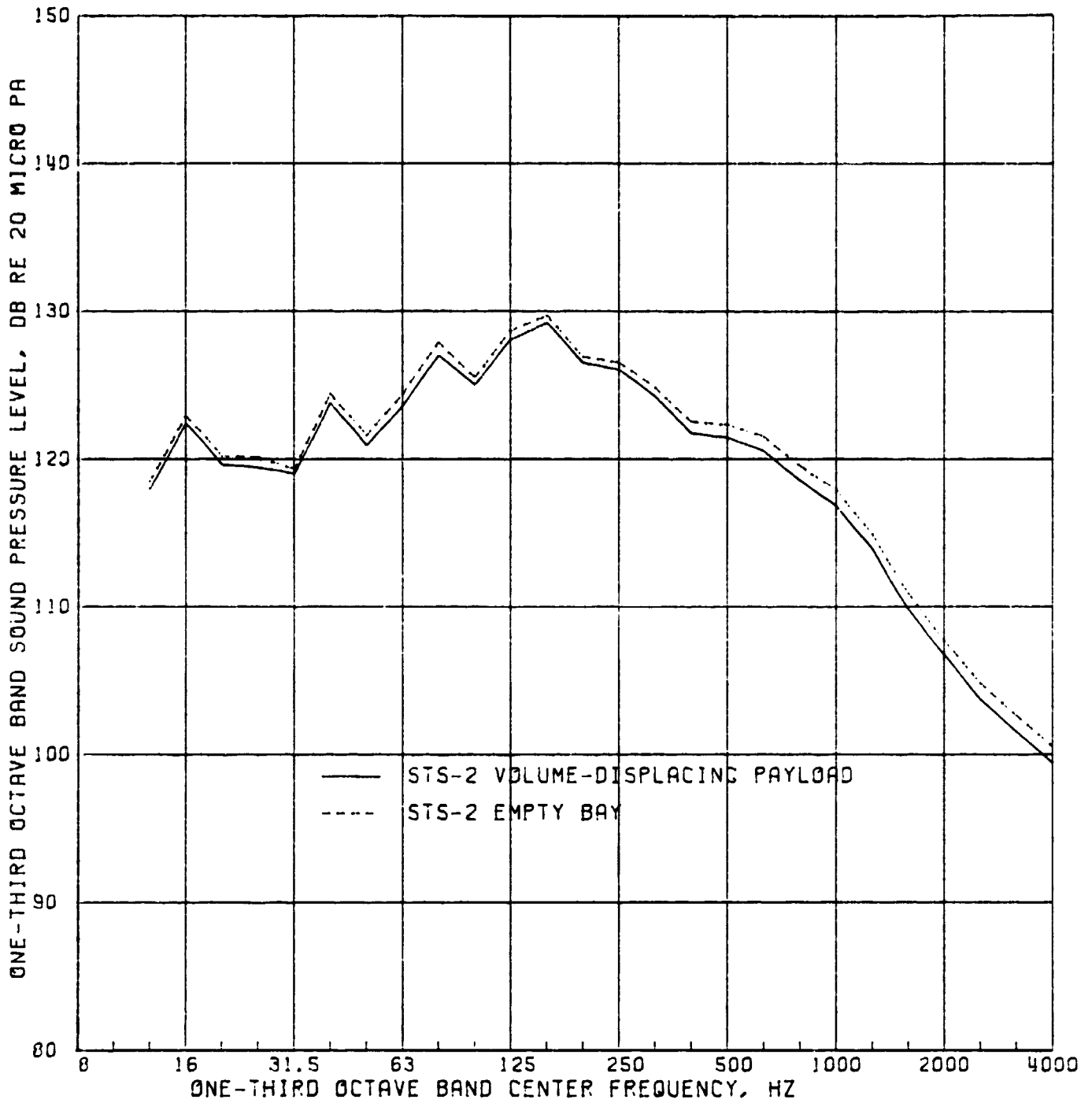

FIGURE 23. PAYLOAD BAY SOUND LEVELS PREDICTED BY PACES FOR SINGLE VOLUME REPRESENTATIONS WITH AND WITHOUT VOLUME-DISPLACING PAYLOAD

payload forming the boundary between the two regions. In this manner it may be possible to investigate fore-and-aft spatial gradients in sound pressure level.

To achieve this idealization without the introduction of spurious modes, the DFI payload was represented as a 0.16m (40 inch) inward deformation to the rear x-surface ( $X = 1184$ ) of the forward subvolume and a similar inward deformation to the forward x-surface ( $X = 1184$ ) of the aft subvolume. In this manner the DFI payload volume was introduced without forming a small subvolume around the payload. The OSTA-1 payload was modeled as a volume-displacing payload in the forward subvolume. (Approximate area and volume of the payload were 51.6 sq.m or 80,000 sq. in, and 10.7 cu.m or 652,000 cu.in). Acoustic absorption coefficients used for the DFI and OSTA-1 payload surfaces are the same as those given in Table 10.

The predicted space-average sound level spectra for the two subvolumes are plotted in Figure 24, where the results are compared with those calculated on the basis of a single volume with a volume-displacing payload (described in Section 6.3). There are only small differences in predicted sound level between the two payload idealizations, but the general trends are interesting. Firstly, with the exception of one or two frequency bands, the sound levels predicted for the two-subvolume idealization are equal to, or lower than, the corresponding levels predicted for the single-volume representation. Secondly, for the two-volume idealization the sound pressure levels are higher in the forward subvolume than in the aft; the differences are small, however, being only 0.7 dB on the average, with a maximum of 1.5 dB.

### 6.5 Comparison with Measured Data

The space-average sound pressure levels predicted in Section 6.3 for a payload bay with a volume-displacing payload can be



ORIGINAL PAGE IS  
OF POOR QUALITY

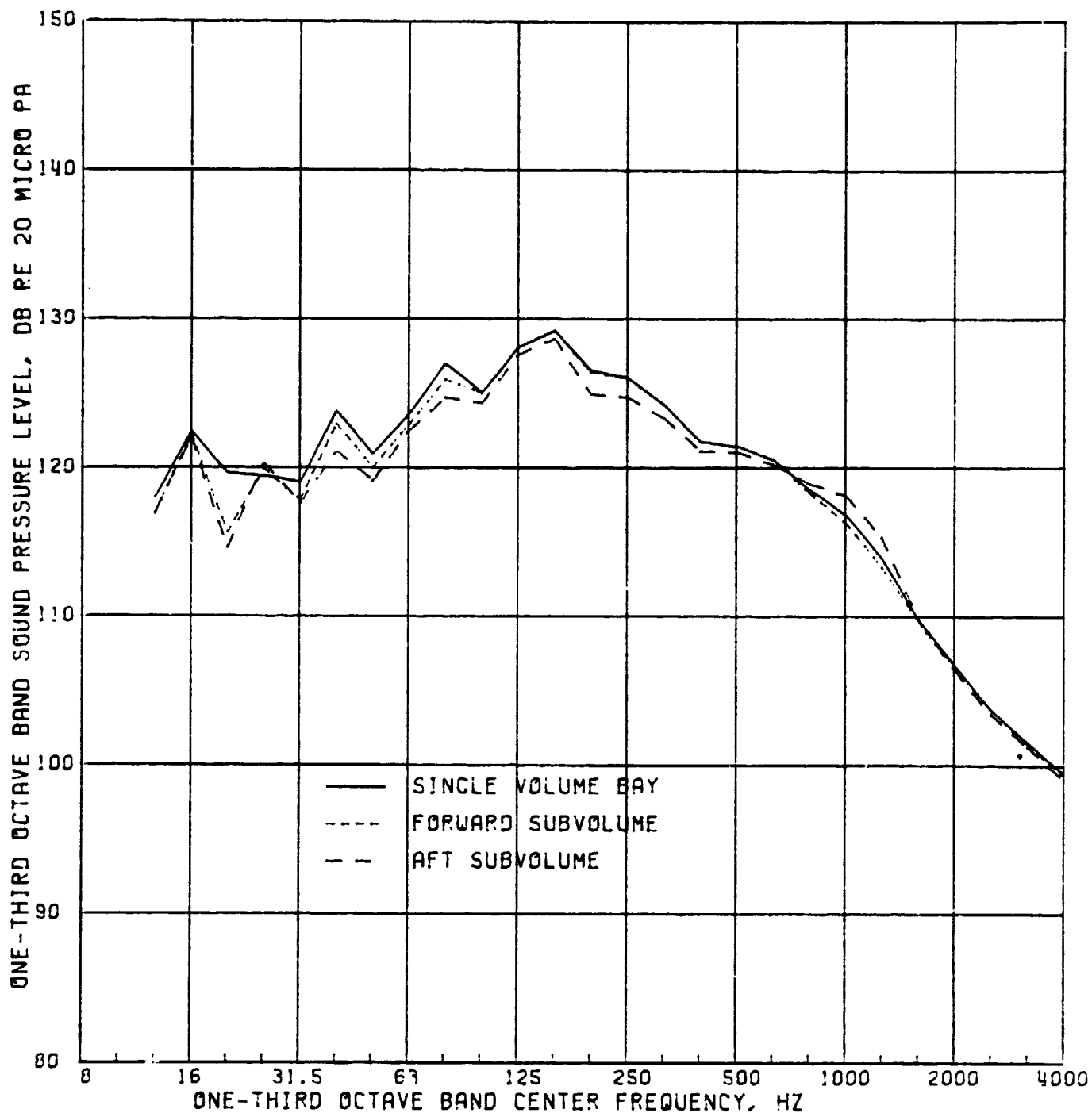

FIGURE 24. PAYLOAD BAY SOUND LEVELS PREDICTED BY PACES FOR SINGLE VOLUME AND TWO-SUBVOLUME REPRESENTATIONS WITH VOLUME-DISPLACING PAYLOADS

compared with corresponding levels determined from the STS-2 launch measurements. In the present case there are two alternative values of the "measured" space-average sound pressure level, as is discussed in Section 4.0. The first "measured" spectrum is based on the bias error correction method of [5], as described in Section 4.1. This spectrum, with associated 95% confidence limits, is compared with the PACES predicted spectrum in Figure 25. A similar comparison is shown in Figure 26, where the measured values are now based on the four-volume average described in Section 4.3.

In both cases the spectrum levels predicted by PACES are slightly higher than the corresponding measured values, with the predictions showing better agreement with the four-volume average than with the average based on the bias error correction method. For example, if the differences between measured and predicted space-average one-third octave band sound pressure levels are averaged for the frequency range 12.5 Hz to 1000 Hz, the PACES program predicts sound levels which are about 2 dB higher than measured values based on four-volume averaging, and 3.5 dB higher than those obtained following the bias error correction method of [5]. Above 1000 Hz the comparison is poor due to contamination of the test data by instrument background noise.

The comparisons can be carried further by considering the predictions for the two-volume idealization. In this case the agreement is quite close for the forward subvolume. For example when the one-third octave sound pressure levels predicted for the forward subvolume are compared with the space-average levels based on measurements in the forward three measurement regions (regions A through C of Table 4), the average difference is only 1 dB. In contrast, the agreement between measurement and prediction is poor for the aft subvolume. These comparisons should be treated with caution, however, since the two-volume idealization is not necessarily appropriate for such a small payload.

ORIGINAL PAGE IS  
OF POOR QUALITY

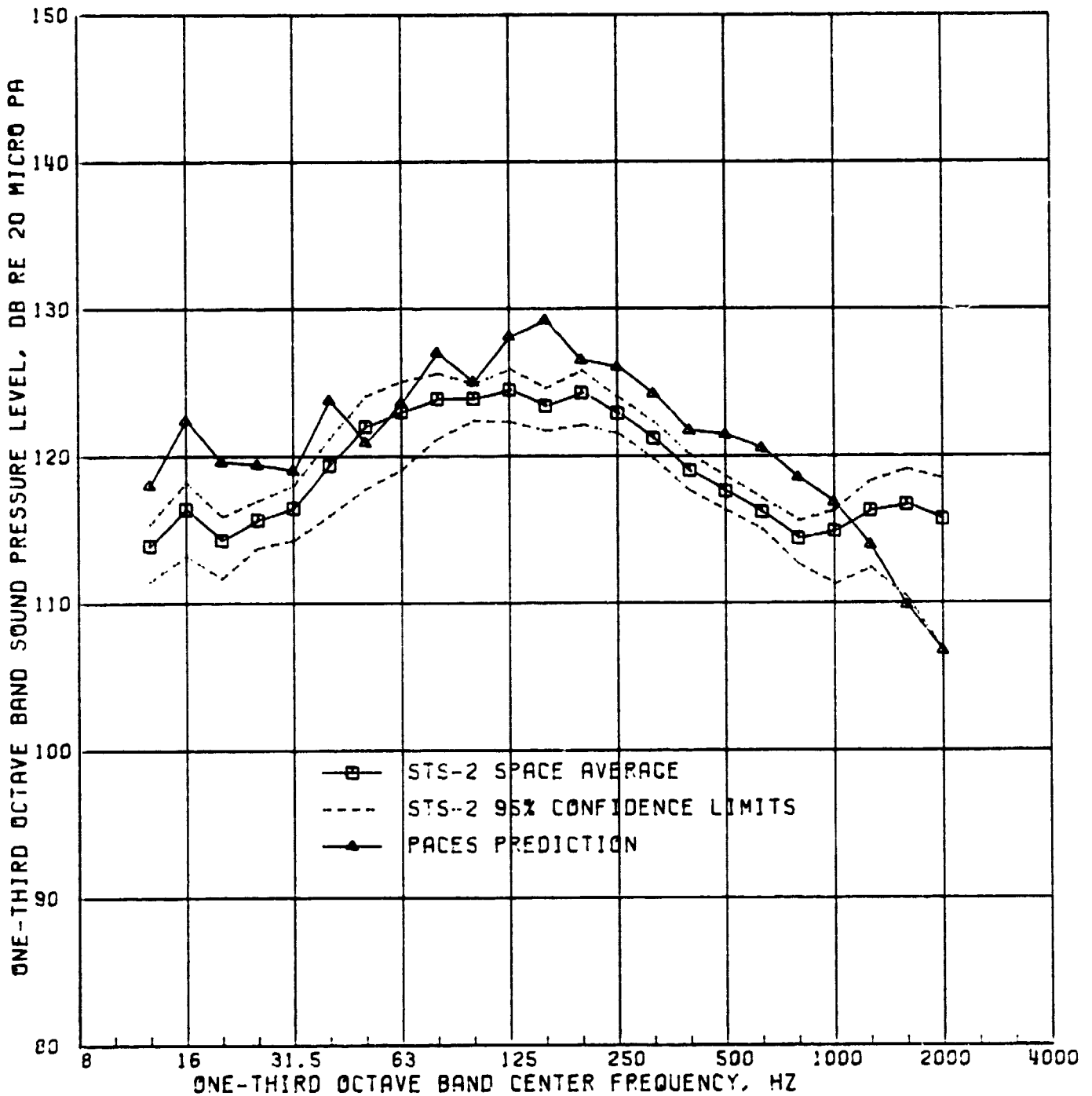

FIGURE 25. COMPARISON OF PREDICTED (SINGLE VOLUME WITH PAYLOAD) AND MEASURED (BIAS ERROR CORRECTION METHOD) SOUND LEVELS

ORIGINAL PAGE IS  
OF POOR QUALITY

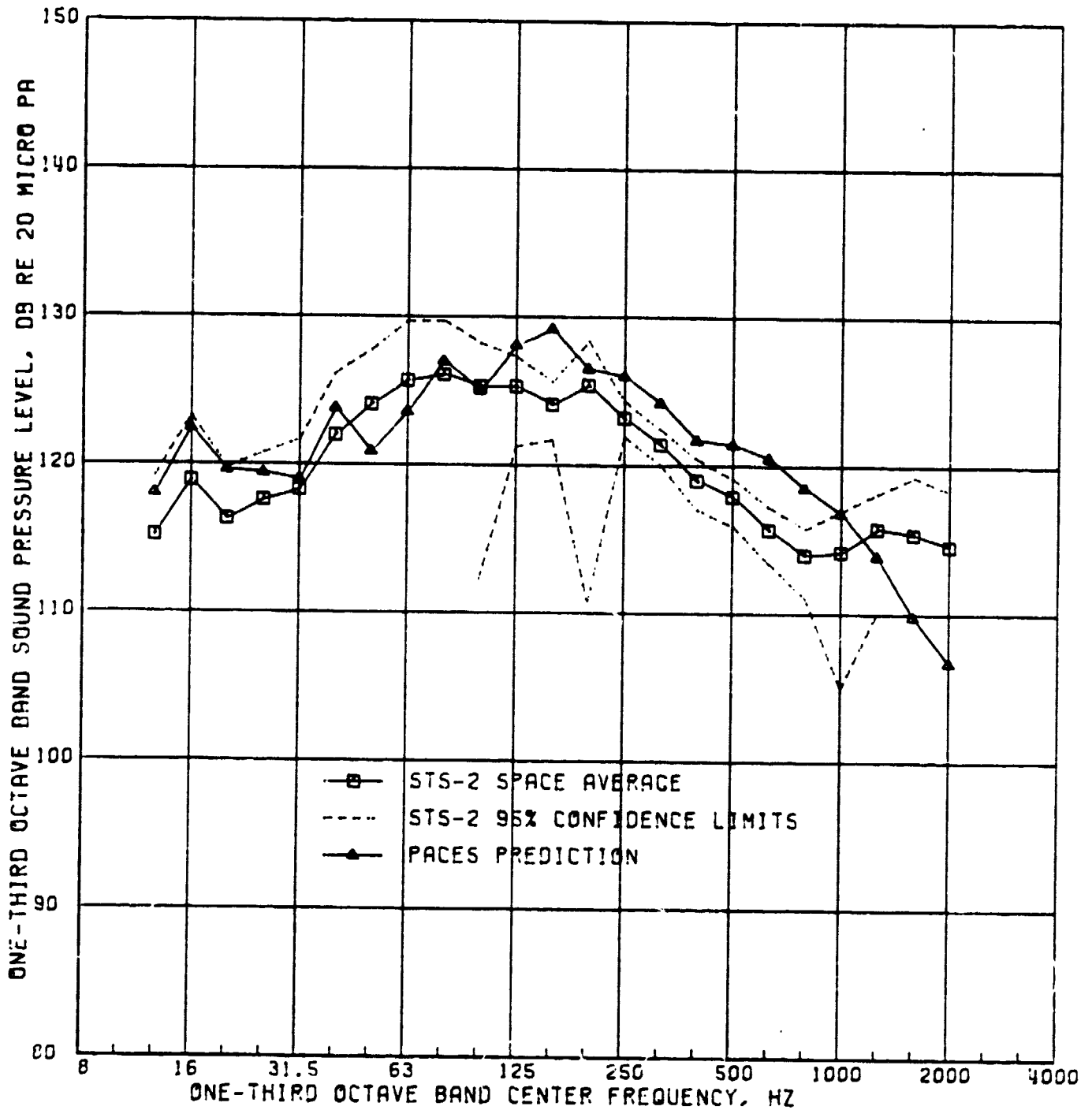

FIGURE 26. COMPARISON OF PREDICTED (SINGLE VOLUME WITH PAYLOAD) AND MEASURED (FOUR-VOLUME AVERAGE) SOUND LEVELS

## 6.6 Influence of Vents

In the analysis of STS-1 data [3], a crude model was developed to represent the noise transmission through the open vents. The effect of the open vents was to increase the acoustic power flow into the bay and, consequently, increase the space-average sound levels in the bay. However, since the model is crude and the accuracy of the estimates for the exterior sound pressure levels at the vent locations is poor, no PACES predictions have been made for STS-2 payload bay interior sound levels with vents open. It is highly desirable that measurements be made in the payload bay to determine the acoustic power being transmitted through the open vent. This is particularly important for large diameter payloads.

## 7.0 CONCLUSIONS

Space-average sound pressure levels computed from measurements at 18 locations in the payload bay of the Space Shuttle orbiter vehicle during the STS-2 launch have been compared with predicted levels obtained using the PACES computer program. The comparisons have been performed over the frequency range 12.5 Hz to 1000 Hz, since the test data at higher frequencies are contaminated by instrumentation background noise.

In general the PACES computer program tends to over-predict the space-average sound levels in the payload bay, although the magnitude of the discrepancy is usually small. Furthermore the discrepancy depends to some extent on the manner in which the payload is modeled analytically, and the method used to determine the "measured" space-average sound pressure levels. Thus the difference between predicted and measured sound levels, averaged over the 20 one-third octave bands from 12.5 Hz to 1000 Hz, varies from 1 dB to 3.5 dB.

One important factor in the evaluation of the PACES computer program is the spatial variation of the measured sound pressure levels in the payload bay. The data show higher sound levels in the forward part of the bay than in the aft. This is in contrast to the spatially-uniform data from the OV-101 and one-quarter scale tests on which the bias error correction procedure [5] was based. To compensate for the spatial variation and the biased distribution of microphone locations, an alternative procedure was introduced whereby the bay was divided into four subvolumes and space-average sound levels determined for each subvolume. A final averaging was then performed to obtain space-average sound pressure levels for the bay as a whole. The resulting sound levels showed closer agreement with PACES predictions than did the data obtained from the bias error correction approach of [5].

Because the present analysis still leaves some questions unresolved, no changes have been made to the PACES computer program. It is proposed that such changes, if any, should await analysis of results for STS-3. Then the analyses of STS-1, STS-2 and STS-3 launch data can be consolidated and any required modifications made to PACES.

References

1. A. G. Piersol et al, "Space Shuttle Payload Acoustics Prediction Study," NASA CR-159956 (5 volumes), NASA Goddard Space Flight Center, Greenbelt, Maryland, March 1980.
2. A. G. Piersol and J. F. Wilby, "An Evaluation of Space Shuttle FRF Acoustic Data," BBN Report 4733, Bolt Beranek and Newman Inc., Canoga Park, California, October 1981.
3. J. F. Wilby et al, "An Evaluation of Space Shuttle STS-1 Payload Bay Acoustic Data and Comparison With Predictions", BBN Report 4738, Bolt Beranek and Newman Inc., Canoga Park, California, November 1981.
4. A. F. White, J. A. Garba, et al, "Payload Bay Acoustic and Vibration Data From STS-2 Flight," DATE Report 003, NASA, January 1982.
5. A. G. Piersol, "Bias Error Corrections For Acoustic Data From Space Shuttle FRF and STS-1 Through STS-3," BBN Report 4547, Bolt Beranek and Newman Inc., Canoga Park, California, December 1981.
6. I. Guttman, S. S. Wilks and J. S. Stuart, Introductory Engineering Statistics, 2nd ed., John Wiley, New York, 1971.
7. M. R. Schroeder, "Effect of Frequency and Space Averaging on The Transmission Responses of Multimode Media," Journal of the Acoustical Society of America, Vol. 46, No. 2 (Part 1), pp 277-283, 1969.
8. A. G. Piersol et al, "Space Shuttle Payload Bay Acoustic Prediction Study, Volume V, Verification of Analytical Model (with Payload), and Overview of Study." NASA Contractor Report 159956 (1980). See Table A-2.