

NASA Contractor Report 166004

NASA-CR-166004
19830005976

A PROPOSED CONFIGURATION FOR A STEPPED
SPECIMEN TO BE USED IN THE SYSTEMATIC
EVALUATION OF FACTORS INFLUENCING WARPAGE
IN METALLIC ALLOYS BEING USED FOR CRYOGENIC
WIND TUNNEL MODELS

D. A. Wigley

KENTRON INTERNATIONAL, INC.
Hampton Technical Center
Hampton, Virginia 23666

UNIVERSITY OF SOUTHAMPTON (SUBCONTRACTOR)
Department of Mechanical Engineering
Southampton, England



Contract NAS1-16000
September 1982

LIBRARY COPY

DEC 1 1982

LANGLEY RESEARCH CENTER
LIBRARY, NASA
HAMPTON, VIRGINIA

NASA

National Aeronautics and
Space Administration

Langley Research Center
Hampton, Virginia 23665

A Proposed Configuration for a Stepped Specimen to be used in
the Systematic Evaluation of Factors Influencing Warpage

by D.A. Wigley
Department of Mechanical Engineering
University of Southampton
Southampton, England.

1. Introduction

In order to obtain the maximum amount of valid data from wind tunnel tests, it is necessary for the dimensions and profile of the model to be measured accurately. Furthermore, it is equally important that the model then retains these known characteristics during subsequent testing cycles. For room temperature wind tunnels a considerable body of knowledge and expertise has been built up over many decades of testing and for most purposes methods have been found to fabricate dimensionally stable models.

The advent of cryogenic wind tunnels has, however, added a further constraint for the model maker in having to ensure that the model is able to maintain dimensional stability during thermal cycling between room temperature and its cryogenic operating environment. This, together with the further requirements of high strength needed to withstand the loads developed during high Reynolds number tests in pressurized tunnels, and the mandatory demand of adequate toughness to avoid brittle fracture at cryogenic operating temperatures, reduces severely the range of materials and fabrication techniques available for producing aerodynamic models for testing in cryogenic wind tunnels.

Much experience has been built up at NASA Langley Research Center on choice of materials and fabrication techniques for models used in the 0.3 meter Transonic Cryogenic Tunnel. Nevertheless, problems have been encountered and one in particular, the warpage of a 15-5PH stainless steel model, led to the author being asked to help diagnose and solve the problem as well as to give advice generally in the fields of Materials and Cryogenic techniques likely to be of interest for testing models in cryogenic wind tunnels. The results of the more general aspects of these studies were presented to the Cryogenic Models

Workshop held at LaRC in May 5-6, 1982, in a paper entitled "The Problem of Dimensional Instability in Airfoil Models for Cryogenic Wind Tunnels." (Ref.1). A further paper on problems encountered with the metallurgical structure of the material chosen for the fabrication of Pathfinder I, entitled "The Metallurgical Structure and Mechanical Properties at Low Temperature of Nitronic 40, with Particular Reference to its Use in the Construction of Models for Cryogenic Wind Tunnels", was also reported at this Workshop (Ref.2).

Many different types of specimen were used by LaRC personnel and the writer to obtain information on the various microstructural and dimensional characteristics of the materials under examination. In some cases LaRC used fully profiled models in order to record their dimensional changes, in other cases wedge shaped specimens were utilised with the thinly tapered portion being representative of the dimensions of the trailing edge of a typical airfoil model. In view of the large number of possible combinations of material, heat-treatment, machining technique and other relevant fabrication processes that need to be evaluated if a firm data base is to be built up, the writer suggested that a simplified, yet representative, stepped specimen configuration should be adopted for the cryogenic airfoil model project.

This report describes in detail this proposed configuration, together with the results of an initial set of machining and measurement cycles carried out by the Gas Bearings Advisory Service of the University of Southampton on a maraging steel, Vascomax 200. Simple thermal cycle tests were also carried out by alternately immersing the sample in liquid nitrogen and then warming to room temperature using a hot air blower. These tests showed Vascomax 200 to possess excellent dimensional stability during cryocycling. An indication of the stress levels generated during machining is also presented, together with suggestions for possible further development of the technique and measuring equipment.

2. Recommended Configuration of a Proposed Standard Specimen for Warpage Experiments

As noted above, one of the prime considerations for the specimen was that it should be simple, and therefore inexpensive to machine, yet capable of yielding accurate and meaningful data relevant to the fabrication of cryogenic wind tunnel models. The recommended configuration for such a specimen is shown in Figure 1.

By limiting the maximum thickness to 12mm it is possible to fabricate a specimen if necessary from $\frac{1}{2}$ -inch thick plate, yet still have enough material to use for a standard 10mm square Charpy V notch specimen should the need arise. Furthermore, the choice of 60mm width x 60mm length also limits the amount of material required to a reasonable quantity.

The proposed configuration allows the use of the flat underside as a reference plane for subsequent measurement as well as providing a firm support for the machining operations carried out on the top face. Furthermore, by adopting a stepped configuration with parallel ledges it is possible to make use of the simple x or y feed mechanisms likely to be fitted to most milling, grinding or other machining equipment. The specimen has 5 different thicknesses in its final form, each step being half that of its predecessor, thus giving thicknesses of 12, 6, 3, 1.5 and 0.75mm respectively. The thinnest 0.75mm (0.030in) step is representative of the trailing edge of many typical airfoil models and gives the most sensitive region of the specimen for observing the effects of fine finishing cuts. Depending on the time available and the specific objective of any particular series of experiments, some of the thicker steps may be machined before creation of the reference flat and the start of the measurement sequence. For example, in the Vascomax 200 specimen the 6mm and 3mm steps were cut before the final heat-treatment that put the material in the required metallurgical condition.

It is also envisaged that the same specimen configuration could be used to evaluate some of the other aspects of cryogenic model making technology that have not yet been satisfactorily resolved. For example, instrumentation, particularly plumbing of the pressure sensing orifices, often requires holes to be drilled, slots milled, and soldering or brazing operations to be carried out, and the effect of these operations on the metallurgical and dimensional stability needs to be checked. Furthermore, many different types of filler material will be required with expansion coefficients compatible to those of the model materials. Some of these fillers will be required to last the lifetime of the model, while others, such as those used to fair up the gaps in models with movable control surfaces will need to be able to withstand a few cryogenic temperature cycles, yet be easily removable when the flap positions need to be changed. Much screening work on potentially suitable materials could be carried out using the proposed stepped sample or possibly scaled down versions with half or one quarter of the width of the standard specimen.

3. Machining and Heat-Treatment Schedule used for Vascomax 200 Sample

Vascomax 200 is a maraging steel with considerable potential for the manufacture of models and other highly loaded components, such as the sting in a cryogenic wind tunnel. Its yield strength of 1860 MPa (270 ksi) at 77K (-320F) makes it one of the strongest of the candidate materials and, although it only absorbs 39 Joules (28ft.lb) in a Charpy impact test at 77K, its toughness is just acceptable for the NTF according to current selection criteria. Furthermore, it behaves extremely predictably during heat-treatment with only small and reproducible changes in dimensions.

Accordingly, it was decided that initial evaluation of the proposed specimen configuration would be carried out on Vascomax 200 and Table 1 gives the schedule of machining, heat-treatment and measurement stages agreed with LaRC personnel.

Table 1

- (a) Rough cut to shape 60mm x 60mm x 12mm
- (b) Machine out 6mm and 3mm steps to leave 3mm step 36mm in length.
- (c) Heat-treat for 4½ hours at 480C (900F): Check macro and microhardness.
- (d) Prepare 60mm x 60mm unstepped face to reference standard.
- (e) Carry out appropriate measurement and mapping.
- (f) Use 0.5in diameter ball end mill to reduce thickness of end 24mm to 1.5mm in 4 stages each removing 375 microns (.015in) with liberal use of fluid to keep workpiece cool.
- (g) Remeasure and map reference surface after each milling stage.
- (h) Recheck microhardness of milled surface (and microstructure?).
- (i) Grind end 18mm to final thickness of 1.5mm, using a maximum depth of cut of 10 microns (.0005in) with liberal use of water based emulsion for cooling and giving a 32 microinch surface finish.
- (j) Remeasure and map reference surface.
- (k) Grind end 12mm step in 3 stages, each of 250 microns (.010in) using a maximum depth of cut of 10 microns (.0005in), same lubrication system and surface finish as for step i).
- (l) Remeasure and map reference surface after each of the 3 steps.
- (m) Recheck microhardness of ground surface (and microstructure?).

4. Details of the Machining and Measurement Techniques Utilized

Material used for the specimen was taken from a piece (4x3x0.5in) given to the writer by LaRC personnel for metallurgical tests. After rough machining to size the specimen was held down for the milling and grinding stages using a magnetic chuck. This technique would obviously be unsuitable for non-magnetic materials such as the 300 series austenitic stainless steels and Nitronic 40. Furthermore, it has been suggested subsequently by LaRC personnel that the use of magnetic hold down chucks has been found by LaRC to encourage warpage, not minimise it, and hence the choice of the most suitable gripping technique will have to be reconsidered for subsequent work.

As received the material was in the annealed condition and Vickers pyramid hardness measurements using a 20kg load gave an average of 304 VPN, which is equivalent to about 32 Rockwell C. The sample was left approximately .020in oversize prior to heat-treatment, which was carried out at 480C (900F) for 4½ hours in an air furnace. Some slight surface discolouration occurred during heat treatment but it was not of serious consequence. Further hardness measurements using 20kg load gave an average of 435 VPN, equivalent to 44Rc, for the heat-treated condition.

The reference surface was then ground flat and finally hand lapped to give a flatness of better than 40 microinches over the whole surface. The specimen was mounted on a specially developed support cradle which enabled it to be supported at 3 points and levelled to establish a datum plane.

(Note: a total of 25 sheets of readings are included as an appendix to the top copy of this report in case further analysis may be needed at some future date. Other copies only have selected readings and collated data).

Measurements were made while traversing the inverted specimen beneath the head of a capacitance probe. The support carriage was mounted on an air bearing and was moved in the longitudinal direction by a motor driven lead screw. Lateral movement was achieved by a hand operated cross feed screw. The ultimate sensitivity of the capacitance probe, which had been made for gas bearing work in the University of Southampton laboratories, was 5 microinches. The output from the probe was digitized for display on a digital meter and it could also be reconverted into an analogue voltage to drive one axis of a pen recorder. Apart from initial

use of the digital meter to set up the levels, output was usually obtained as continuous traces on the pen recorder chart. In most measuring cycles, six longitudinal traces were recorded at intervals of approximately 10mm across the width of the specimen. As far as was possible traces recorded during subsequent measurement were taken at the same positions to allow direct comparison between measurement. As noted in the previous section, measurements were made after each separate stage of milling and grinding so that the progress of the deformation could be monitored.

5. Deflections Created by Ball End Milling and Surface Grinding

A typical set of longitudinal traces is shown in Figure 2 (Trace 2L) as taken after the first 375 micron (.015in) milling cut made with a new 0.5in diameter ball ended cutter inclined at an angle of 15 degrees to the vertical. The sensitivity of the plot is .001in per cm on the graph paper, and at this sensitivity the original out-of-flatness of the reference surface (<40 microinches) would be less than the width of the pen recorder trace. As can be seen, all the traces shown an upward curvature towards the thinner end at the right hand side of the figure. The curves are essentially flat and parallel to each other for the first 36mm, which corresponds to the unmachined portion of the specimen, and they then bend up in a circular arc in the machined region. It should be noted that, as the specimen was inverted, an upward deflection of the reference surface implies the generation of a compressive stress in the machined face.

The other feature noticeable on these traces is the general downward slope from left to right in Figure 2. This occurred because two of the supporting points were located along the 12mm thick unmachined edge at the left hand side, while the third was near the extreme right hand end. An upward deflection of this end therefore created a general downward movement of the reference plane. In later measurements this bias was removed by locating the third point of support at about 30mm from the thick end, at a point virtually unaffected by the various machining operations.

The effect of 4 milling cuts of 375 microns (.015in) on the end 24mm, one 75 micron (.003in) grind over the end 18mm and 3 grinding stages each of 250 microns (.010in) over the end 12mm of the sample are all collated together in Figure 3, together with a profile of the resultant stepped specimen. The

traces are inverted as compared with Figure 2 because it makes it easier to assimilate the results in the context of the schematic profile shown above the traces. Two representative sets are illustrated from the six actually measured, one along the centre span of the sample and the other along its extreme right hand edge.

The effect of the successive ball end milling operations is strikingly evident as the traces are progressively lower. Once again, the sensitivity of the measurements is such that the original out of flatness errors are less than the thickness of the trace. The two sets of traces are generally similar but those on the extreme right hand side seem to start slightly nearer the unmachined end than those at the center.

The effect of the first 75 micron (.003in) grinding stage is even more dramatically illustrated by the traces. The maximum deflection at the end of the sample drops from about 125 microns (.005in) to 75 microns (.003in) at centre span and from about 175 microns (.007in) to 50 microns (.002in) at the extreme right. The characteristic shape of the trace also alters, from the smooth circular arc formed after ball end milling to a distinct change of slope between two almost linear sections, the change of slope coinciding almost exactly with the end of the ground portion of the specimen.

Although it is not very easy to pick it out in the collated traces of Figure 3, it is possible to see that after the final grinding operation on the end 12mm of the specimen, the trace reverses its slope slightly inferring the presence of tensile stresses in the ground surface.

There are two possible explanations for this change in character from ball end milling to grinding. In one, grinding would be held to induce tensile stresses into the surface which partially offset the compressive stresses that had been introduced previously by the ball end milling. Alternatively, it may be that the localised heating created by grinding, even with liberal water cooling, caused a partial annealing of the previously induced compressive stresses. Simple experiments in which all the profiling were achieved by grinding should help to decide which of these explanations is most likely.

It is also of interest, and possible practical significance, that these results indicate that it might be possible to control warpage by a judicious

mixture of ball end milling and grinding. Introduction or relief of compressive or tensile stresses in the appropriate locations might minimise or even correct unwanted distortion.

A further set of traces was generated in each measuring cycle by traversing the specimen laterally beneath the head of the capacitance probe. As the cross feed screw was hand operated, it was difficult to ensure reproducibly scaled traces on the pen recorder. As can be seen from Figure 4 (trace 2W), the ends of each trace do not lie at the same positions although each was created by a complete traverse across the 60mm wide specimen. Accordingly it is necessary to rescale the traces from each series of measurements so that they can be compared directly. The maximum deflection of the end of the specimen along the centre span can be measured from the longitudinal traces such as those in Figure 2. Once this is established the positions of the other points on the lateral traces can be determined by scaling.

The collated and rescaled lateral traces of the deflections created by the various ball end milling and grinding operations are given in Figure 5, together with a schematic end view of the stepped specimen. It can be seen that the ball end milling operations cause the corners to be deflected downwards even more strongly than the centre, giving the sample an anhedral effect. This effect is indicative of compressive stresses having also been introduced in a lateral direction across the width of the sample. Once again the dramatic effect of the subsequent grinding operation is clearly demonstrated by a reduction in the deflection at the center of the end of the specimen. Furthermore, the corners are now at a higher level than the center giving the sample a dihedral effect and also inferring the presence of tensile stresses in the ground surface.

6. Results of Simple Cryocycling Tests

In order to get as much information from this specimen as quickly as possible, the microhardness and microstructure checks were omitted and a series of simple cryocycle tests carried out between room and liquid nitrogen temperatures. A 4BA tapped hole was positioned centrally in the 12mm thick end face so that the specimen could be supported on a thin steel rod. A full series of remeasurements was carried out at this stage and they confirmed that no

dimensional changes had taken place due to possible mishandling of the specimen between the end of the previous series of tests and the start of the cryocycling tests.

For the first test, the specimen was held just above the liquid nitrogen surface for a few minutes to minimise its cooling rate when subsequently immersed. It was then held in liquid nitrogen until bubble evolution ceased, thereby indicating that it had reached thermal equilibrium with the liquid nitrogen. The specimen was then withdrawn from the liquid nitrogen and allowed to warm slowly to ambient temperature. A full series of measurements was then carried out and their results showed that there had been no measurable dimensional changes as a result of the cryogenic temperature cycle. All traces taken before and after the cryocycle could be superimposed to an accuracy of better than the thickness of the pen recorder trace.

Encouraged by this initial success, a more brutal series of cryocycles followed in which the specimen was plunged into liquid nitrogen until bubble evolution ceased, then warmed rapidly to room temperature using ambient temperature air from a blower. A complete cooling and warming cycle took approximately 10 minutes, and a total of 18 such cycles were carried out before a further series of measurements were undertaken. Comparison with the previous set of traces showed that even this treatment caused no movement - an impressive demonstration of the stability of Vascomax 200 in a cryogenic environment.

7. Approximate Calculation of the Stresses Induced by Ball End Milling

As noted earlier, the compressive stresses induced by ball end milling forced the end of the specimen to deflect downwards in an approximately circular arc. If it is assumed that the arc is circular a rough indication of the stresses involved can be calculated from standard beam theory.

Referring to Figure 6, if the length of the chord is $2c$, and the central deflection is a , then the skin stress F is given by

$$F = \frac{E.t.a}{a^2+c^2} = \frac{E.t.a}{c^2} \quad \begin{array}{l} E \text{ is the Elastic Modulus} \\ t \text{ is the beam thickness.} \end{array}$$

In the case of the four cuts made with the ball end mill, the machined length was 24mm, hence $2c \approx 24\text{mm}$. Working from the original traces gives values of a of 10, 16.5, 22.5 and 30 microns respectively after the four cuts, the corresponding thicknesses being 2.62, 2.25, 1.87 and 1.5mm respectively. These results are collated in Table 2, together with the calculated stresses in Ksi and MPa/m^2 for the skin stress.

Table 2
Data and Calculations for Stresses Induced by
Ball End Milling

	Unit	Number of Cuts			
		1st	2nd	3rd	4th
Deflection, a	microns	10	16.5	22.5	30
Thickness, t	mm	2.625	2.25	1.875	1.5
$a.t$ ($\times 10^{-2}$)	mm^2	2.625	3.71	4.22	4.5
c^2	mm^2	144	144	144	144
$a.t/c^2$ ($\times 10^{-4}$)	-	1.82	2.58	2.93	3.12
Modulus, E ($\times 10^6$) psi	psi	-----		29	-----
$F = E.a.t/c^2$	ksi	5.3	7.5	8.5	9.0
Modulus, E	GN/m^2	-----		200	-----
$F = E.a.t./c^2$	MN/m^2	36	52	59	62

It can be seen that the induced compressive stresses appear to build up progressively as the number of cuts increases and that the increasing deflections are not just a result of the steady decrease in beam thickness. The magnitudes of the stresses calculated are, of the order of $35\text{--}65 \text{ MPa/m}^2$ ($5\text{--}9\text{Ksi}$) are of the same order as those reported in the literature of reference 1.

Because of the change in characteristic shape of the traces after grinding, away from an arc of a circle to a change of slope between two almost linear sections, it is not possible to use this method to calculate the residual stresses in the specimen.

8. Possible Future Developments in the Measuring Technique and Use of the Stepped Specimen

The only piece of equipment made specifically for this project was the supporting frame on which the inverted specimen was mounted. As noted earlier, the longitudinal traces were produced in an easily reproducible manner because the supporting frame was motor driven in this direction. The first obvious logical development of the equipment would be to fit a similar motor drive to replace the hand operated lead screw for transverse measurements so that they too were more reproducible and directly comparable.

If an extensive programme of work were to be considered worthwhile, it would also be worth considering the development of a computer controlled system in which the traces were measured under software control. This would cut down the man-hours required for each series of measurements, as with the present system measurement is timeconsuming and therefore expensive.

A further extension, which would only be justified if a considerably larger programme of work were to be considered, would be to store the already-digitised output from the capacitance probe in the computer memory. This would enable a complete survey of the sample surface to be stored in the form of (x co-ordinate, y co-ordinate deflection) array variables which could be subsequently recalled and processed to generate maps of the contours on the reference plane, or other sophisticated forms of data display.

Although such developments would not be inexpensive, they would enable much worthwhile data to be generated from a properly coordinated and controlled programme on warpage in candidate model materials. Such a programme should be able to generate a database which would help to remove much of the present uncertainty and mystique from the causes of dimensional instability in high precision airfoil models. Much of the potential value of such a programme would, however, be lost if it were fragmented and unco-ordinated to such an extent that the results from different materials and machinery techniques could not be systematically evaluated and meaningfully compared.

9. Conclusions

(i) A proposed configuration for a stepped specimen for use in the systematic evaluation of warpage is presented in detail.

(ii) The initial results from a sample of Vascomax 200 show that the configuration and measuring technique are capable of giving high quality, quantitative results.

(iii) Ball end milling induces compressive stresses into the machined surface of magnitude $35-65 \text{ MPa/m}^2$ (5-9Ksi).

(iv) Subsequent surface grinding either anneals some of the previously induced compressive stresses, or introduces tensile stresses which partially compensate for the compressive stresses induced by ball end milling.

(v) Cryogenic cycling between room and liquid nitrogen temperatures does not create any further dimensional changes in Vascomax 200.

(vi) A co-ordinated programme of work using the proposed stepped specimen configuration could enable a useful data base of information to be generated on the effects of various machining and heat-treatment cycles on a range of candidate materials for cryogenic wind tunnel models.

(vii) The stepped specimen, or sub-standard sizes, could also be used for evaluating other factors of interest to cryogenic wind tunnel models - for example the compatibility of filler materials with substrates.

10. Acknowledgments

Mr. R. Woolley and Mr. D. Whyard of the Gas Bearings Advisory Service, University of Southampton, for the machining and metrology carried out on the prototype stepped specimen.

11. References

1. Wigley, D.A. "The Problem of Dimensional Instability in Airfoil Models for Cryogenic Wind Tunnels". NASA High Number Contractor Report No. CR 166003 . Also presented at the Cryogenic Models Workshop, LaRC, May 5-6th 1982.
2. Wigley, D.A. "The Metallurgical Structure and Mechanical Properties at Low Temperature of Nitronic 40, with Particular Reference to its Use in the Construction of Models for Cryogenic Wind Tunnels". NASA High Number Contractor Report No. CR165097, April 1982. Also presented at the Cryogenic Models Workshop, LaRC, May 5-6th 1982.

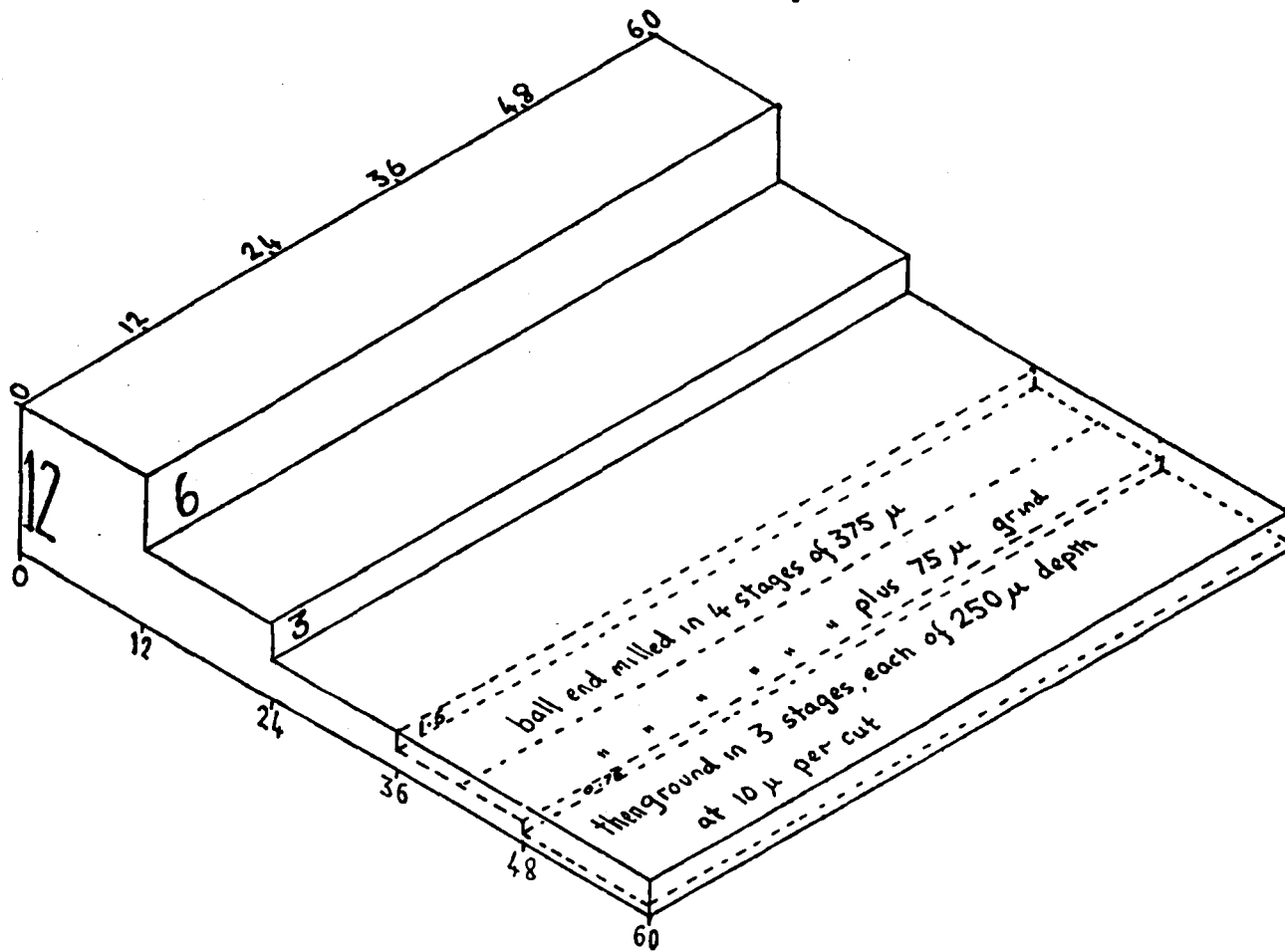

Figure 1: Recommended Configuration of Proposed Standard Specimen for Warpage Experiments. (Dimensions in mm.)

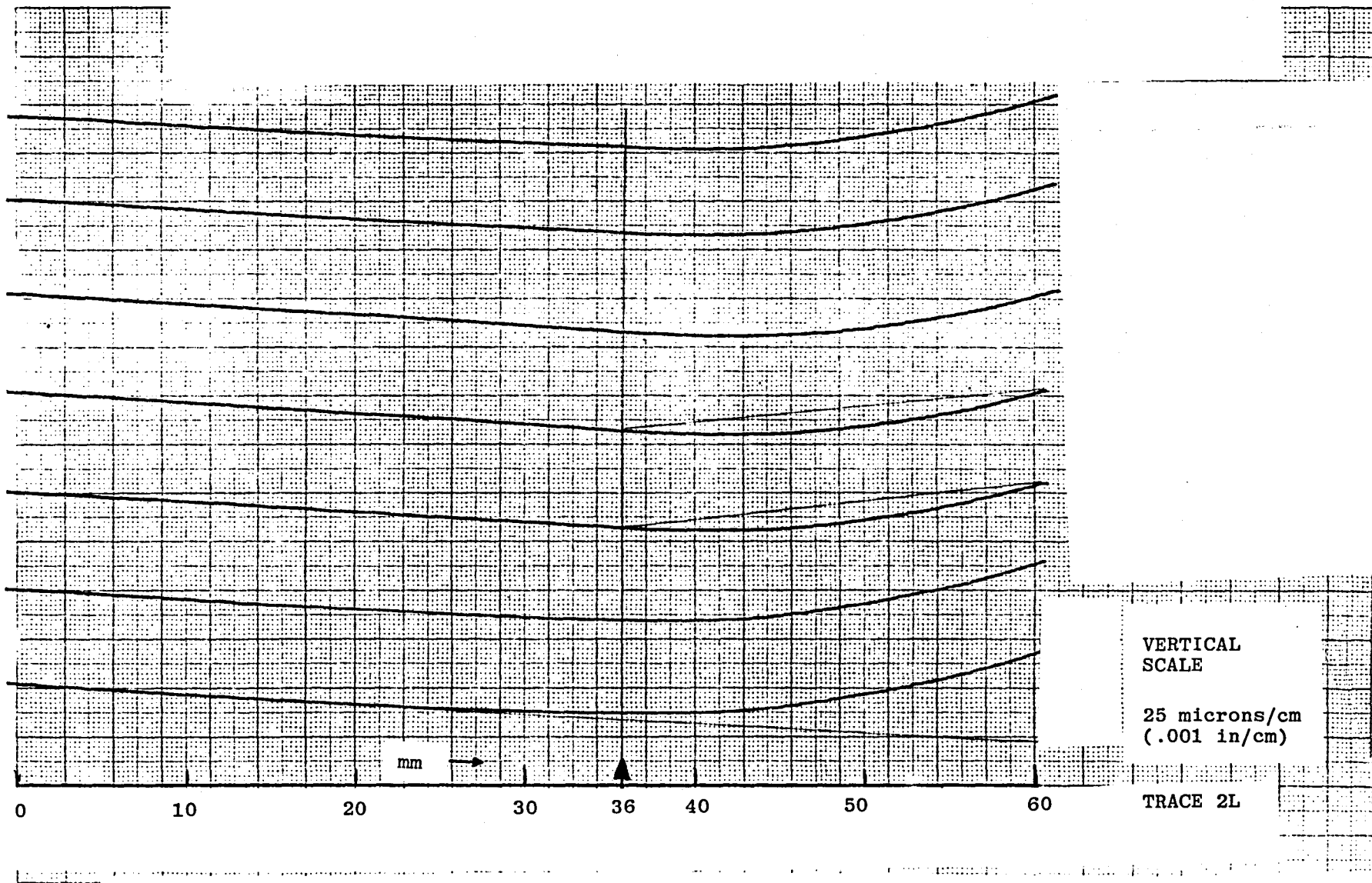
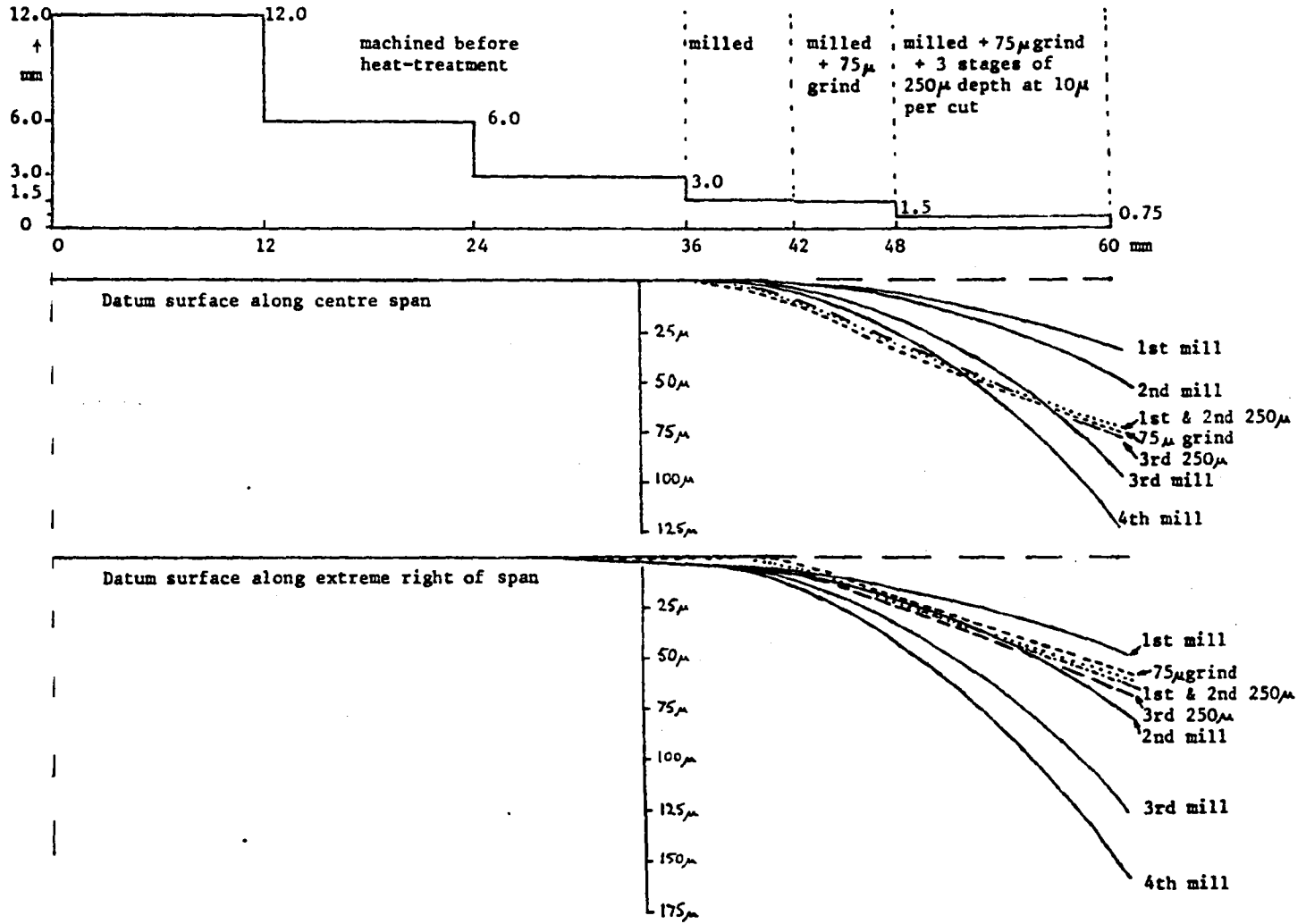

FIG. 2. FIRST 375 MICRON (.015 in.) CUT WITH BALL END MILL.

Figure 3 Longitudinate profiles of machined Vascamax 200



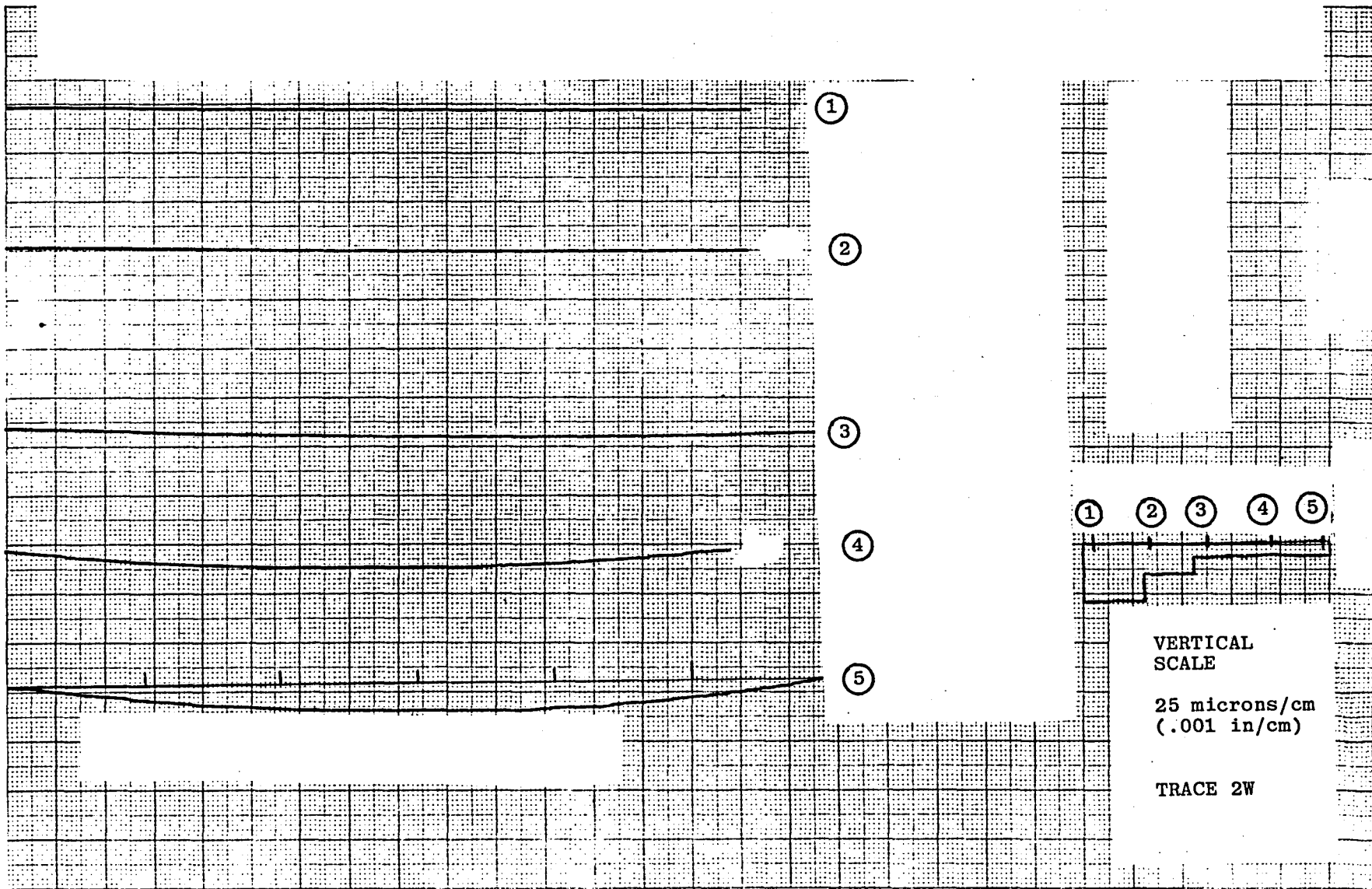

FIG. 4. FIRST 375 MICRON (.015 in.) CUT WITH BALL END MILL

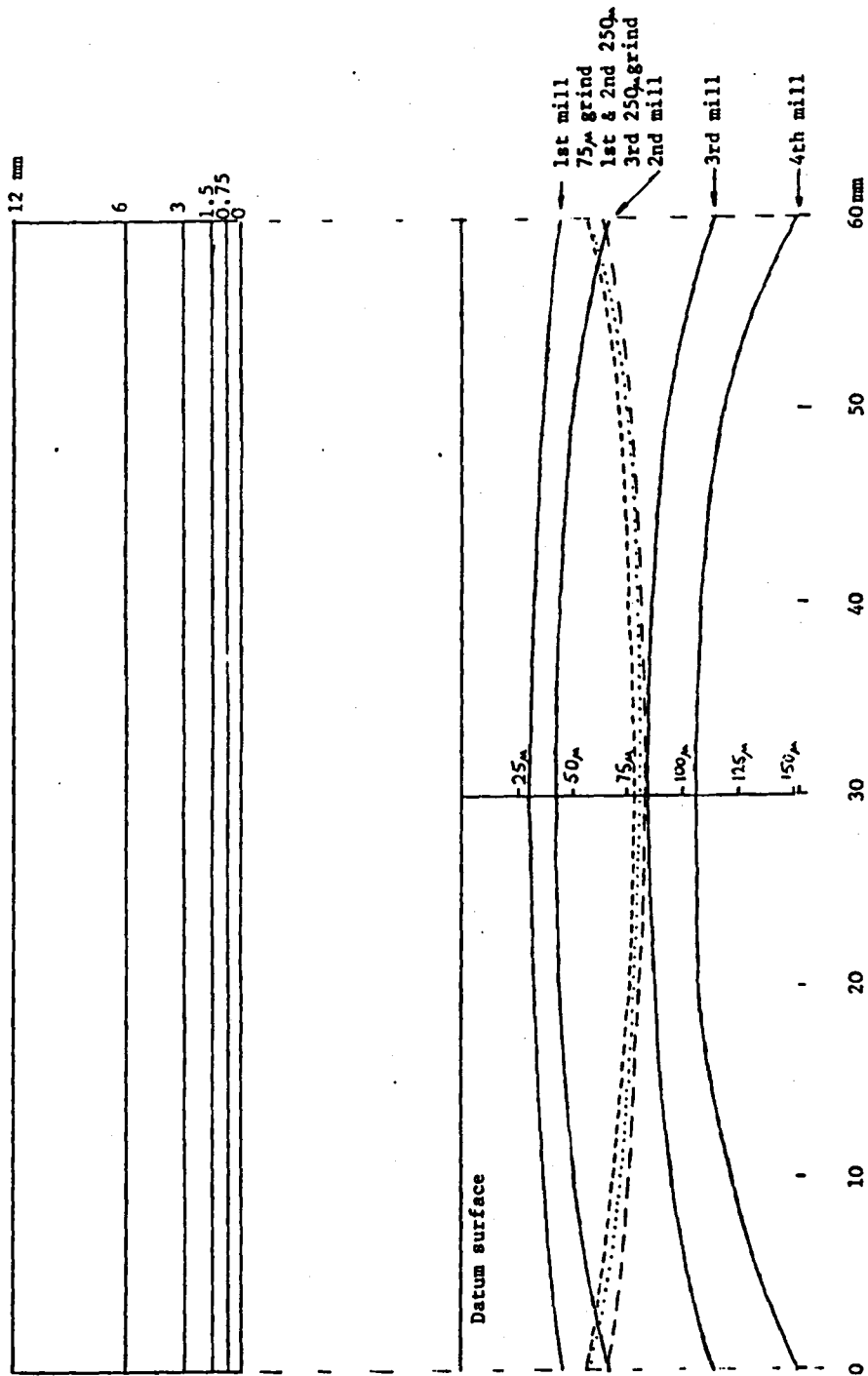

Figure 5 Transverse profiles of machined Vascomax 200

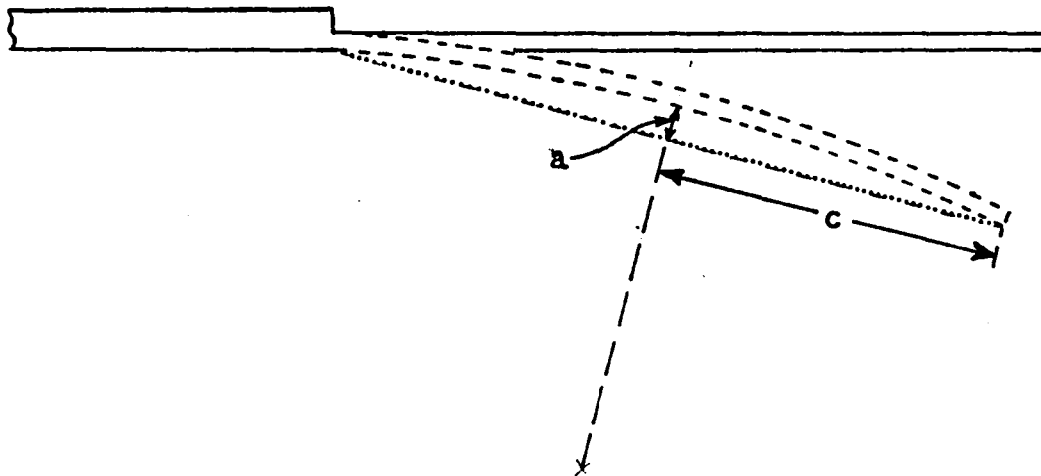

Figure 6: Relevant Dimensions for Calculation of Skin Stresses Induced by Milling.

1. Report No. NASA CR-166004		2. Government Accession No.		3. Recipient's Catalog No.	
4. Title and Subtitle A PROPOSED CONFIGURATION FOR A STEPPED SPECIMEN TO BE USED IN THE SYSTEMATIC EVALUATION OF FACTORS INFLUENCING WARPAGE IN METALLIC ALLOYS BEING USED FOR CRYOGENIC				5. Report Date September 1982	
				6. Performing Organization Code	
7. Author(s) WIND TUNNEL MODELS D. A. Wigley				8. Performing Organization Report No.	
				10. Work Unit No.	
9. Performing Organization Name and Address Sub-Contractor: Kentron International Inc. The University of Southampton Hampton Technical Center Department of Mechanical Eng'g 3221 North Armistead Avenue Southampton Hampton, VA 23666 England				11. Contract or Grant No. NAS1-16000	
				13. Type of Report and Period Covered Contractor Report	
12. Sponsoring Agency Name and Address National Aeronautics and Space Administration Washington, DC 20546				14. Sponsoring Agency Code	
15. Supplementary Notes Dr. D. A. Wigley is a lecturer in the Department of Mechanical Engineering, the University of Southampton, England. Langley Technical Monitor: Dr. Clarence P. Young, Jr.					
16. Abstract A proposed configuration for a stepped specimen to be used in the system evaluation of mechanisms that can introduce warpage or dimensional changes in metallic alloys being used for cryogenic wind tunnel models. Considerations for selecting a standard specimen are presented along with results obtained from an investigation carried out for VASCOMAX 200 maraging steel. Details of the machining and measurement techniques utilized in the investigation are presented. Initial results from the sample of VASCOMAX 200 show that the configuration and measuring techniques are capable of giving quantitative results.					
17. Key Words (Suggested by Author(s)) Cryogenic Wind Tunnel Models Dimensional Instability Specimen Cryogenic Materials Residual Stresses Machining Effects on Metallic Alloys			18. Distribution Statement Star Category - 26 Unclassified - Unlimited		
19. Security Classif. (of this report) Unclassified	20. Security Classif. (of this page) Unclassified	21. No. of Pages 20	22. Price A02		

End of Document