

NASA Contractor Report 168344



Design Study for a Ground Microwave Power Transmission System for Use with a High-Altitude Powered Platform

(NASA-CR-168344) DESIGN STUDY FOR A GROUND
MICROWAVE POWER TRANSMISSION SYSTEM FOR USE
WITH A HIGH-ALTITUDE POWERED PLATFORM Final
Report (Raytheon Co.) 136 p HC A07/MF A01

N83-32180

Unclass

CSG 10B G3/44 28492

W. C. Brown

June 1983



National Aeronautics and
Space Administration

Goddard Space Flight Center
Wallops Flight Facility
Wallops Island, Virginia 23337

NASA Contractor Report 168344

**Design Study for a Ground Microwave
Power Transmission System for Use
with a High-Altitude Powered Platform**

W. C. Brown

**Raytheon Company
Microwave Power Tube Division
Waltham, Massachusetts 02154**

Prepared Under Contract No. NAS6-3200



**National Aeronautics and
Space Administration**

**Goddard Space Flight Center
Wallops Flight Facility
Wallops Island, Virginia 23337**

TABLE OF CONTENTS

<u>Section</u>		<u>Page</u>
0	SUMMARY	
1.0	INTRODUCTION	1.1
2.0	BACKGROUND DATA AND OTHER FACTORS CONSIDERED IN THE DESIGN OF THE GMPTS	2.1
2.1	Assumptions Specified by the Work Statement	2.1
2.1.1	Choice of 2.45 GHz (12.26 cm) as the Frequency	2.2
2.1.2	Power Density of the Microwave Beam Impinging Upon the Rectenna on the LTA Vehicle- 175 watts/ meter ² Originally but Revised to 400 watts/meter ²	2.2
2.1.3	Linear Polarization of the Transmitting Antenna and Control of the Polarization Alignment Between the Transmitting Antenna and the Rectenna by the Rotation of the Transmitting Antenna	2.4
2.1.4	The Vehicle Shall Always Be in the 3 dB Antenna Beamwidth of the Ground Antenna	2.6
2.2	Design Considerations Imposed Upon the GMPTS by the Design of the LTA-HAPP Vehicle and Its Flight Characteristics	2.10
2.2.1	Impact of the High Peak Power Requirements of the LTA-HAPP Vehicle Upon GMPTS Design	2.10
2.2.2	Impact of the Assignment of the Rectenna to a Specific Area of the LTA-HAPP Upon GMPTS Design	2.11
2.2.3	Impact of the Flight Characteristics of the LTA- HAPP Vehicle Upon GMPTS Design	2.13
2.3	Availability of Component Technology for Design- ing and Construction of a System in the Near Time Frame	2.14
2.4	Background of Component and System Technology from Which GMPTS Design Was Selected	2.15
2.4.1	Microwave Antenna Technology	2.15
2.4.1.1	Discussion of Various Antenna Approaches	2.15
2.4.1.2	Technology for the Radiating Module	2.17
2.4.1.3	Method for Fabricating Low-Cost Slotted Wave- guide Modules from Thin Gauge Aluminum Sheet	2.17

PRECEDING PAGE BLANK NOT FILMED

TABLE OF CONTENTS (CONTINUED)

<u>Section</u>	<u>Page</u>
2.4.2 Technology for Microwave Power Generation and Amplification, Control of Amplitude and Phase of Microwave Output, and Interface with the Source of DC Power	2.23
2.4.2.1 General Discussion	2.23
2.4.2.2 Potential Long Life of the Magnetron in the GMPTS	2.30
2.4.3 Beam Steering and Phasing Control System	2.33
2.5 Cost Minimization Procedures	2.38
2.5.1 Introduction	2.38
2.5.2 Derivation of Expression for Minimum Life-Cost of the GMPTS	2.38
2.5.3 Microwave Power Density at the Transmitting Antenna Face for Minimum Life Cycle Cost and as Given Uniquely by the Ratio of the Cost Parameters a and $m + bc/n_1$	2.44
2.5.4 Limitations on Applications of Analysis in 2.5.2	2.45
2.5.5 Using the Expressions of Cost for Sensitivity Analysis	2.45
2.6 Conversion of 60-Cycle Power into Filtered DC Power	2.50
2.7 RFI-FMI Considerations	2.51
2.8 Thermal Design	2.52
2.9 Mechanical Design	2.53
3.0 DESIGN OF THE GROUND-BASED MICROWAVE POWER TRANSMISSION SYSTEM GMPTS	3.1
3.1 Introduction	3.1
3.2 Design for Microwave Beam Pointing, Focussing, and Retaining Polarization Alignment with Rectenna Rotation	3.7
3.2.1 Interface of the Phase Control Matrix with the Radiating Module	3.8
3.2.2 Phasing Information Generation and Distribution	3.10
3.2.2.1 The Determination of the Amount of Phase Control by the Interferometric Tracking of the Pilot Signal; Pilot Signal Transmitter	3.10
3.2.2.2 Digitizing and Distribution Phase Change Information - Mathematical Modeling	3.14

TABLE OF CONTENTS(CONTINUED)

<u>Section</u>		<u>Page</u>
3. 2. 2. 3	Distribution of Clock Phase Reference and Bore-Sighting	3. 18
3. 2. 3	Retaining Polarization Alignment with Rectenna Rotation	3. 24
3. 2. 4	Zoom Lens Capability	3. 26
3. 2. 5	Correction for Expansion of the Array	3. 27
3. 3	Microwave Power Generation and Distribution System	3. 30
3. 3. 1	Introduction	3. 30
3. 3. 2	Configuration of the Microwave Driver and Final Amplifier Chain	3. 31
3. 3. 3.	Details of Microwave Drive Power	3. 33
3. 3. 4	Design of the Microwave Subarray	3. 35
3. 3. 4. 1	The Slotted Waveguide Array Subassembly	3. 36
3. 3. 4. 2	The Power Distribution and Phasing Subassembly	3. 39
3. 3. 4. 3	The Magnetron Directional Amplifier Subassembly	3. 41
3. 3. 4. 4	Magnetron Starting, Stopping, and Protection from Arcing	3. 42
3. 4	The Conversion of 60-Cycle Power at the Utility Connection Into DC Power for the Magnetrons and for Other Power Requirements	3. 45
3. 5	Estimated Costs for the GMPTS and Their Significance	3. 48
4. 0	EXPERIMENTAL DATA FOR CRITICAL AREAS	4. 1
4. 1	Uniformity of Phase Over the Central Portion of a Single Radiation Module with Single Excitation	4. 1
4. 2	Adapting the Commercially Available Microwave Oven Magnetron to the GMPTS by Repackaging It	4. 3
4. 2. 1	Fitting the Commercially Available Magnetron with a Buck-Boost Coil	4. 4
4. 2. 2	Setting the Tube on Frequency and Increasing the Coupling	4. 8
5. 0	ADDENDUM	5. 1

LIST OF ILLUSTRATIONS

<u>Figure No.</u>		<u>Page</u>
1. 1	Artist's Sketch Illustrating Modularized Transmitting Antenna for Transmitting Power to the Rectenna on the Underside of a Lighter-Than-Air Vehicle Flying at 70,000 Feet Altitude	1. 3
1. 2	Diagram Showing Relationship Between the Phased-Array Transmitting Antenna and the Airborne Vehicle	1. 4
2. 1	Transmission Efficiency - Molecular Absorption and Rain	2. 3
2. 2	Decrease in the Density of the Microwave Beam as a Function of Off-Axis Pointing	2. 8
2. 3	1 TA-HAPP Power Requirements as % of Total Operating Time	2. 12
2. 4	Method for Precision Forming and Assembly of Low-Cost, Thin-Walled, Slotted Waveguide Radiating Modules	2. 19
2. 5	Back View of the 8 x 8 (8 Slots in Each of 8 Waveguides) Slotted Waveguide Array as Constructed from 0.020 Inch Aluminum Sheet Throughout and Assembled by Means of Spot Welding	2. 20
2. 6	Front View of the 8 x 8 Slotted Waveguide Array	2. 21
2. 7	Antenna Pattern for 64 Slot Radiating Module That is Directly Applicable to the GMPTS Requirements	2. 22
2. 8	Schematic Showing How the Phase and the Amplitude of the Magnetron Directional Amplifier Output are Controlled by Phase and Amplitude References and Feedback Control Loops	2. 25
2. 9	Amplitude Tracking Data with Series Resistance of 100 ohms to Simulate Operation From a Hard Voltage Bus	2. 26
2. 10	Conventional Microwave Oven Magnetron that has been Modified by the Addition of a Buck-Boost Coil	2. 27
2. 11	Schematic Diagram Indicating the Principle of the Magnetron Directional Amplifier	2. 29
2. 12	Life of the Microwave Oven Magnetron as a Function of Microwave Power Output. Shown also are the Filament Temperatures at Three Operating Points	2. 31
2. 13	Experimentally Observed and Theoretically Predicted Relationship Between Cathode Temperature and Anode Current for Two Magnetrons with Optical Windows for Viewing Cathode Temperature	2. 32
2. 14	Interferometer Approach to Tracking of the HAPP Vehicle. Interferometer Tracks Vehicle by Nulling on Pilot Signal Emitted from Center of Rectenna in Open Loop Mode. Tracking Loop is closed by Amplitude Sensors at Edges of Rectenna. If pickup is not Equal, an Error Signal is Telemetered to the GMPTS Tracking System.	2. 35

LIST OF ILLUSTRATIONS (Continued)

<u>Figure No.</u>	<u>Page</u>	
2.15	Diagram Showing the Interrelationships Between the GMPTS Parameters of Radiating Module Size, Overall Transmitting Antenna Area, and Emitted Microwave Power and Microwave Power Density Received by HAPP Vehicle as Function of Altitude and Off-Axis Location	2.41
2.16	Value of the Cost Multiplier Factor M (Equation 11) as a Function of the Side Dimension of the Radiating Module and the Off-Axis Location of the HAPP Vehicle. Off-Axis Angle is expressed in Terms of Radians. 0.05 Radian is 2.87 Degrees and Corresponds to an Off-Axis Location of 1 Kilometer at an Altitude of 20 Kilometers. A Value of \$100 was used for Both a_1 and a_2 in Equation (11).	2.47
3.1	Reference Design of the Ground-Based Microwave Power Transmission System (GMPTS) for the LTA-HAPP Vehicle Showing the Modularized Construction and the Microwave Drive Chain. The GMPTS Consists of 1352 Subarrays Each of Which Consists of a Magnetron Directional Amplifier with its Associated Components and Four Slotted Waveguide Radiating Modules Whose Phase and Amplitude are Controlled.	3.2
3.2	Diagram Indicating the Flow of Information Between the GMPTS and the LTA-HAPP Vehicle and How This Information is Used to Control the Pointing of the Beam, to Maintain Polarization Alignment of the GMPTS and the Rectenna, and to Control the Level of Microwave Power Density Upon the Rectenna.	3.5
3.3	Interface of the Phase Control Matrix with the Radiating Module	3.9
3.4	Principle of Operation of the Microwave Interferometer Used to Track the Position of the LTA-HAPP Vehicle. Two Interferometers are used, One Tracking the LTA Around the Y-Axis of the GMPTS and the Other Around the X-Axis of the GMPTS	3.12
3.5	Phase Control Matrix Diagram Showing that Two Numbers a and b, Derived from Interferometer Tracking Data are Sufficient to Control the Pointing of the Array. Response of Array is Therefore Very Fast. Phase Control Matrix System can also be used to Approximate a Zoom Lens and to Make Corrections for Dimensional Changes Caused by Temperature Changes.	3.15
3.6	Diagram Showing: (1) Distribution of Clock-Phase Reference, and (2) Arrangement for Use of Laser Beam to Boresight the Antenna.	3.19

LIST OF ILLUSTRATIONS (Continued)

<u>Figure No.</u>		<u>Page</u>
3.7	Diagrams showing the Details of the Calibration Procedure in which All of the Radiating Modules are made to Radiate with the Same Phase. This is Equivalent to Boresighting the Antenna for Focus at Infinity. Focussing the Antenna on a Closer Point is made Possible by the Use of the Phase Shifter in the Laser Transmitter.	3.21
3.8	Schematic of Microwave Power Subsystem Showing Final Stage and Two Driver Stages as deployed on the X-Axis of the GMPTS in Figure 3.1	3.34
3.9	Subarray Assembly as Viewed from the Back (Non-Radiating) Side	3.37
3.10	Schematic Showing (1) How Directional Amplifier Functions to adapt Itself to a Changing Line Voltage while producing a Prearranged Amount of Microwave Power Output, and (2) How It is wired into a Common DC Power Bus.	3.43
3.11	Circuit Diagram of Centralized DC Power Supply for GMPTS	3.47
4.1	Exploded View of Microwave Oven Magnetron fitted with a Buck-Boost Coil. Mounting Plate has been removed from Magnetron Tube as It is now manufactured in order to insert Buck-Boost Coil into the Tube's Magnetic Circuit. Buck-Boost Coil, as shown in Picture, is a Small Coil consisting of 200 Turns of Copper Wire.	4.5
4.2	Reassembled Tube after Buck-Boost Coil has been Added	4.6
4.3	Experimental Data indicating the Relationship between Ampere Turns in the Buck-Boost Coil and the Operating Voltage of the Tube and the Power required for the Buck-Boost Coil	4.7

SUMMARY

This study was concerned with the design for a ground microwave power transmission system (GMPTS) for use with a high altitude powered platform (HAPP). It may be considered as a companion study to an earlier study that involved the airborne portion of the system as applied to a lighter-than-air (LTA) HAPP vehicle. However, the results of both studies also have broad application to other types of atmospheric microwave powered platforms, such as the airplane or the helicopter, and even to earth-to-space power transmission systems.

The requirement imposed upon the study of the GMPTS was that it should focus and point a microwave beam of the required power density upon a receiving array attached to an LTA that was flying at an altitude of 20 kilometers and that was free to move within a confinement circle of 1.5 kilometers in diameter. The required power density varied from a few watts per square meter to a maximum of 500 watts per square meter, depending principally upon the wide variability in the winds. Likewise, the total power delivered could vary from a few kilowatts to as much as 250 kilowatts.

The active phased array approach was chosen for the general design approach. The resulting design is a 38 x 76 meter transmitting antenna made up of a mosaic of 1352 subarrays each 1.5 meters square. Each subarray contains four slotted waveguide radiating modules whose output phase is individually controlled. Each subarray also contains one microwave generator together with suitable means to distribute the microwave power and to control its output.

The transmitting array is free to rotate in azimuth but not in elevation. It tracks the rotation of the LTA-HAPP by mechanical rotation; it tracks any lateral displacement of the vehicle by electronically steering the beam. Electronic steering is achieved by two microwave interferometers that track the elevation of the LTA-HAPP around the X and Y axes of the GMPTS by nulling the signal received from a pilot beam in the HAPP vehicle. The angular displacement of these interferometers is used to control the individual output phase of each of the 5408 radiating modules and therefore the beam pointing through a digitized phase control matrix.

The design approach to the GMPTS takes advantage of the fixed frequency and limited angular scan requirements of the application to produce a unique electronically-steerable phased array technology that is characterized by its low cost relative to other kinds of phased arrays. The GMPTS design also makes use of readily available components in critical design areas.

The design arrived at in this study should be considered as a reference design only. It is the result of an incomplete series of design reiterations and therefore subject to subsequent changes as new data is accumulated and the design is reiterated further. The physical size of the array and its power consumption were influenced by cost minimization techniques developed during the early part of the study period to minimize the sum of the initial installation cost and the cost of energy consumed during the life of the system. However, any estimates of GMPTS cost made in this study carry with them a high degree of uncertainty because of the lack of cost experience with this kind of phased array and an uncertainty as to how costs will be influenced by further reiteration and study.

Note on Addendum

After the submission of the draft of the final report, it was discovered that it would be possible to both simplify and improve the performance of the design concept with the use of a phase-locked high gain magnetron directional amplifier.

However, incorporation of the principle into the text and illustrations of the final report would involve much additional effort. It is therefore discussed in a short Addendum at the end of the report.

1.0 INTRODUCTION

The concept of a high altitude powered platform (HAPP) that receives the power that it needs for propulsion and payload from a microwave beam, and that can stay on station for long periods of time performing useful communication and surveillance functions is not a new concept.^{(1.1)*} However, the development of this concept as a system was preempted by the rapid development and success of the geosynchronous satellite. Two major factors are now reviving interest in the HAPP concept. The first factor is major breakthroughs in the technology associated with microwave power transmission^{(1.2) (1.3)} and the second is the recognition that high altitude atmospheric platforms can complement the use of geosynchronous satellites, and indeed for some applications may be more suitable.^(1.4 through 1.10)

The subject matter of this report is the design of the ground-based microwave power transmission system (GMPTS) for a lighter-than-air (LTA) vehicle that is kept on station at an altitude of 20 kilometers by power derived from a microwave beam. The study has been useful from a number of points of view. First, it has better defined the factors that are critical in interfacing the microwave beam with the air vehicle. Secondly, it represents the first attempt to apply a large data base and body of knowledge to the design of a ground-based transmitting antenna for the specific purpose of supporting a microwave powered HAPP in the earth's atmosphere. Some of this data base, notably the experimental data on the radiating module and subarray, is of recent origin and greatly enhances the credibility of the concept. Third, it has developed a method for addressing the life cycle cost that is applicable not only to LTA-HAPP's but to other kinds of vehicles as well.

Although this report relates directly to the LTA vehicle and more particularly to one in which the form and size of the receiving array on the LTA have been well defined, the broad conceptual design of the GMPTS is equally applicable to heavier-than-air (HTA) vehicles.

* References are given at the end of each report section.

The general concept of the LTA HAPP system is shown in Figure 1.1. In this concept the transmitter on the ground converts ordinary 60-cycle electrical power into microwave power and radiates this energy in the form of a well-controlled microwave beam which is focussed upon the rectenna that is located on the underneath side of the balloon. The transmitting antenna in the illustration rotates as the heading of the LTA vehicle changes to maintain maximum power transfer.

The specific interface that exists between the microwave power transmission system for an airplane or a balloon of conventional configuration is shown in Figure 1.2. The balloon or airplane maneuvers in a region directly above the transmitting antenna, denoted as the "vehicle containment space." The vehicle may be circling, doing a figure 8 or executing other maneuvers if the wind is changing direction or is below a certain critical value for the vehicle. If the wind velocity is high enough, the vehicle can fly directly into the wind and remain stationary with respect to the earth.

Regardless of where the vehicle is within this containment space, the microwave beam must be kept focussed upon the air vehicle. The peak power density within this focal spot is determined by the needs of the aircraft while the diameter of the spot and the total power within it is determined by the desire to keep the cost of the microwave power transmission system to a minimum.

The beam is kept focussed upon the aircraft by an electronically steerable transmitting array that reacts to a change in the position of a microwave beacon that is located in the center of the rectenna of the vehicle and that also reacts to telemetered signals from amplitude sensors located at the extremities of the rectenna. The guidance system changes the phase of the microwave outputs of the radiating modules in the transmitting antenna with respect to each other and it is this that determines the pointing direction of the beam.

The transmitting antenna can thus be viewed as a phased array, but the conceptual design of the array is greatly different from that of the phased array

~~ORIGINAL PAGE
COLOR PHOTOGRAPH~~

ORIGINAL PAGE IS
OF POOR QUALITY

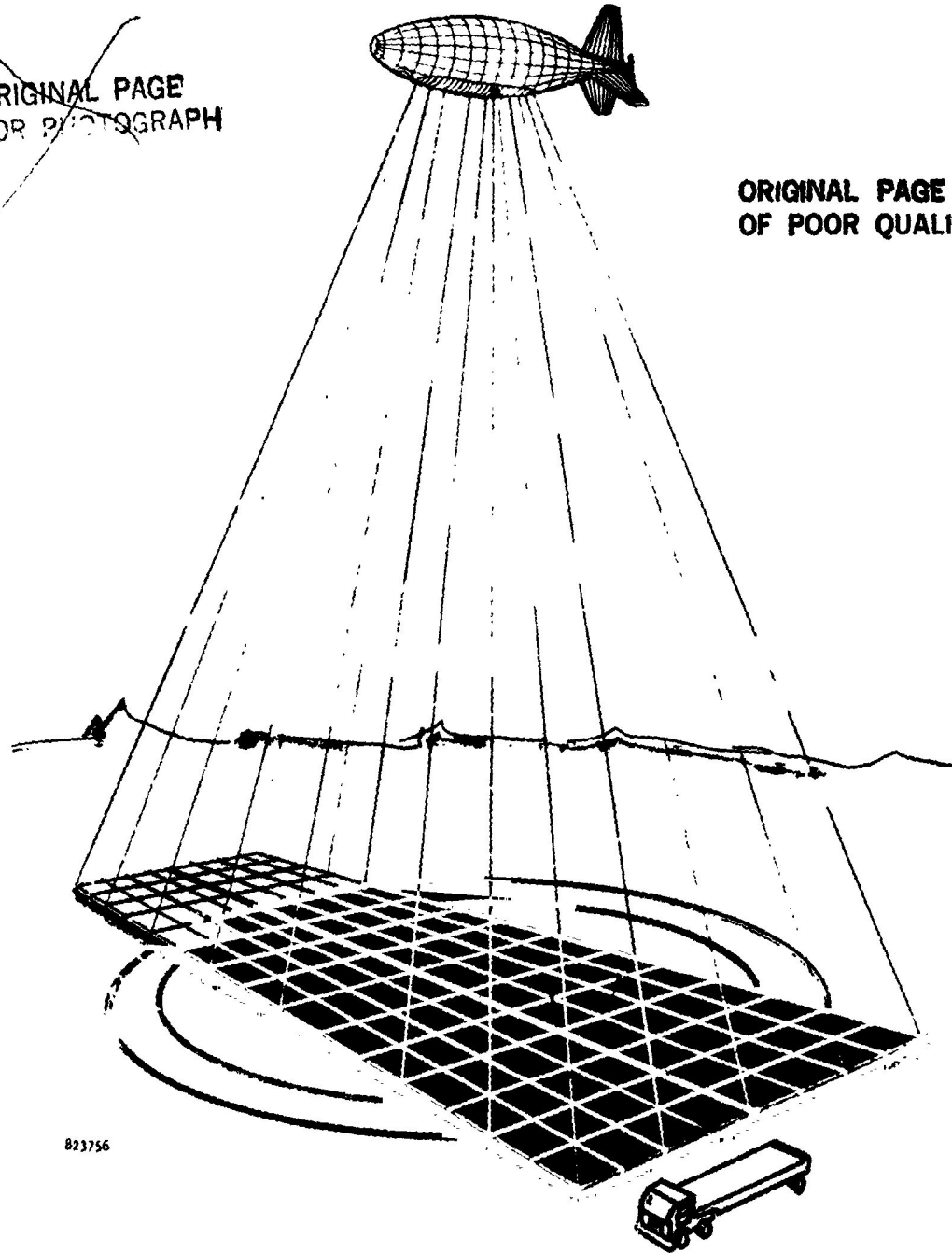

Figure 1.1 Artist's Sketch Illustrating Modularized Transmitting Antenna for Transmitting Power to the Rectenna on the Underside of a Lighter-Than-Air Vehicle Flying at 70,000 Feet Altitude

~~ORIGINAL PAGE
COLOR PHOTOGRAPH~~

ORIGINAL PAGE IS
OF POOR QUALITY

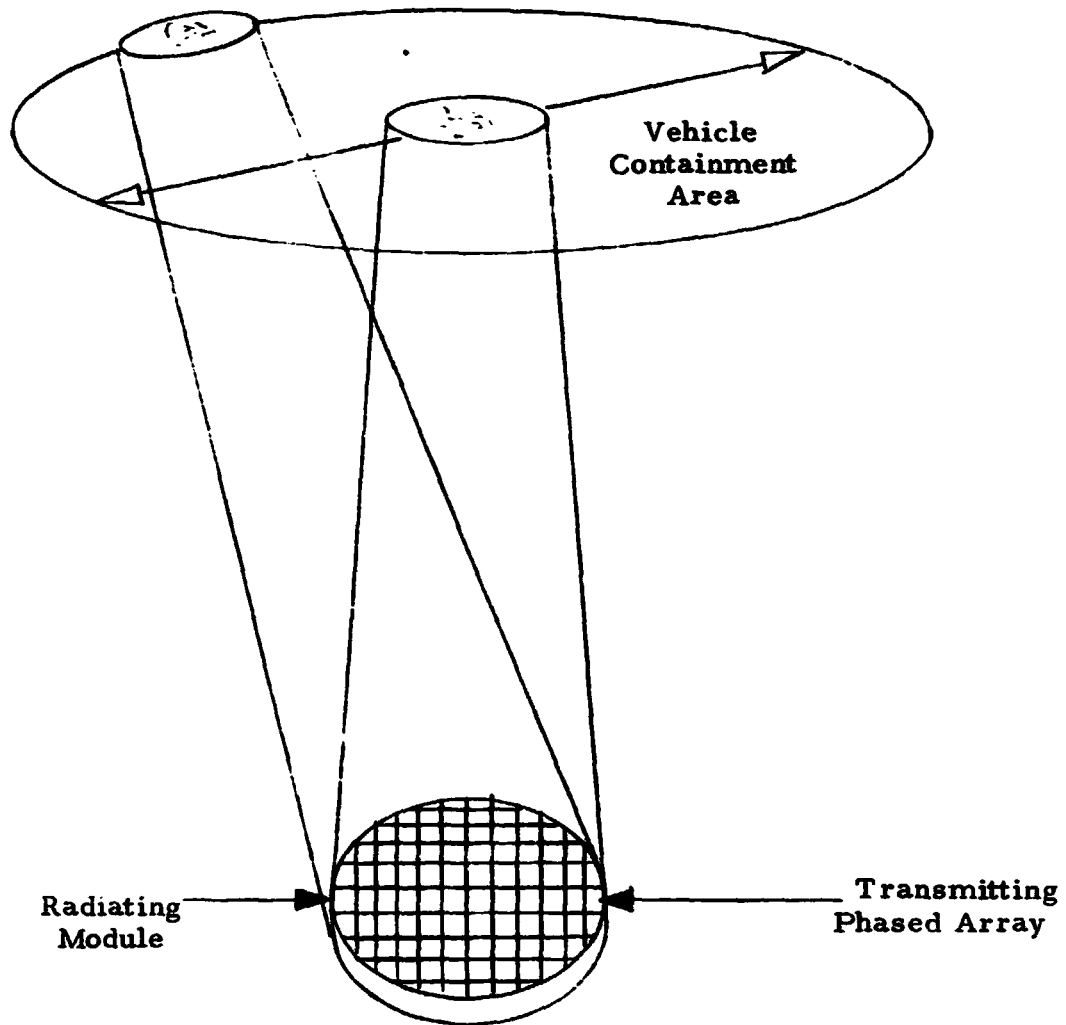

Figure 1.2 Diagram Showing Relationship Between the Phased-Array Transmitting Antenna and the Airborne Vehicle

ORIGINAL PAGE IS
OF POOR QUALITY

used for most radar applications. In the conventional phased array, the phase of each radiating element (half wave dipole or waveguide slot) is controlled individually to allow the beam to cover any point in a cone with an angle typically of 90° . In the transmitting antenna for a microwave powered atmospheric vehicle, this cone angle is reduced to 6° . This means that a large number of adjacent radiating elements, typically 50 to 200, can be grouped together to radiate at the same phase. This reduces the cost of the array because of a reduction by a factor of 50 to 200 in the number of phase shifting components needed.

The phased array for a microwave power transmission system is simplified and made more economical in other respects as well because it is a fixed frequency system. Because of this, it is possible to use a simplified phase reference system and to use very low cost and highly efficient but relatively narrow band microwave generators for the relatively large amounts of microwave power that is to be radiated.

Although the elements of reduced angle coverage and single frequency greatly reduce the cost of the transmitting antenna, the problem still remains of how to design the GMPTS for minimum cost. Fortunately, the elements referred to in Figure 1.2 can be mathematically related to each other and the cost can be modelled in terms of these relationships (Section 2.5). Then the cost model can be mathematically manipulated to minimize either the initial cost or the life cycle cost. Although cost models have been previously used for microwave power transmissions systems, the cost model developed in this study for the first time takes into account the cost of energy used during the life of the system, and the tradeoff between the increase in cost of the phase control electronics and the increase in the power density at the edge of the containment area as the size of the radiating module is decreased.

The GMPTS study has produced a "reference" design which is described in considerable detail in Section 3.0. Still, the design must be considered as conceptual in nature with the design detail and reiteration severely restricted by the support level for the contract. As a result, the study has given priority

**ORIGINAL PAGE IS
OF POOR QUALITY**

first to the microwave aspect, secondly to the non-microwave electronic aspect, third to the interface of the 60-cycle source of power with the GMPTS, and little priority on the mechanical design of the supporting structure and its mechanical rotation. The study has given high priority to uncovering and removing any problems peculiar to the kind of phased array approach used. For example, considerable effort was spent on the details of how the array could be boresighted. Considerable thought was also given to adapting the microwave oven magnetron, purchased as a shelf item, to the GMPTS. These special investigations are described in Section 4.0.

It should be realized that the "reference" design can not be considered as the final conceptual design for the LTA-HAPP system for several reasons. The first reason has to do with changes in the specifications of the peak wind velocity which the LTA may encounter. A change upward in this velocity to reflect conditions often encountered in the higher latitudes and whose impact is reflected in this study increased the power demands from the microwave power transmission system by a factor of four over those previously considered. ^(1.8) However, systems to be used in the lower latitudes could be designed at much more moderate power levels. The second reason has to do with changes caused by reiteration of the design with its subsequent impact upon estimated costs, a process that often suggests simplification, integration, or substitution that impacts the design.

The study has failed to get a narrow-range cost estimate for a production unit whose cost would reflect additional reiteration of the design from that of the reference design, as well as the learning experience acquired from building a number of units of established design. Under these circumstances, the best perspective on the cost problem may be that given by the cost sensitivity analysis in Section 2.5.5. However, it is believed that the cost estimates in Section 2.5.5 do not adequately reflect the cost of the supporting structure and the installation of the network of services required by the subarrays. Because of these uncertainties, the estimate of the production cost of the stationary GMPTS in 1982 dollars varies from a low of \$1,500,000 to as much as \$3,500,000. To this must be added the cost of being able to rotate the structure for those applications where it is necessary to do so.

Likewise, the study has failed to get an estimate of the costs to build the first engineering model for reasons that the reference design is neither mature enough nor detailed enough to use for this purpose. In addition, the cost of the first engineering model is highly dependent upon the manner in which the development is organized. A very rough estimate would place the engineering model cost at about three times the production stage cost, but only if a logical development program is followed.

It is believed that key elements in a properly conceived development program would be:

- (1) Develop the subarray prototype with major considerations being given to designing it for minimum production cost.
- (2) Build a scaled-down version of the array and use either a beam riding helicopter or a tall overhead crane with necessary modifications to check out the performance of the scaled down GMPTS. This could be an array of area 100 to 200 square meters.
- (3) Proceed to build a full scale GMPTS that is consistent with an LTA-HAPP vehicle whose power requirements could have been substantially modified because of being tailored to a particular operational site.

Because of the unique nature of both the purpose and the conceptual approach to the GMPTS, a special effort was made in Section 2.0 of this report to provide background in the form of applicable technology and also in the form of explanations for certain assumptions that were made in the work statement and which limited the generality of the study.

In concluding the Introduction, it is noted that this study is closely related to a previous study on the receiving array or rectenna for the LTA-HAPP (1.12) and an ongoing study of the design of the vehicle itself. (1.8)

REFERENCES FOR SECTION 1.0

- 1.1 W. C. Brown, "Experiments Involving a Microwave Beam to Power and Position a Helicopter," IEEE Trans. on Aerospace and Electronic Systems, Sept. 1969, pp. 692-702.
- 1.2 W. C. Brown, "Status of the Microwave Power Transmission Components for the Solar Power Satellite," IEEE Trans. Microwave Theory and Techniques, Vol. MTT-29, No. 12, Dec. 1981, pp. 1319-1327.
- 1.3 R. Dickinson, "Evaluation of a Microwave High-Power Reception-Conversion Array for Wireless Power Transmission," JPL Tech. Memo 33-741, Sept. 1975.
- 1.4 S. W. Fordyce, "Applications of Free-Space Microwave Power Transmission," Astronautics and Aeronautics, Sept. 1979.
- 1.5 J. W. Sinko, "High Altitude Powered Platform Cost and Feasibility Study," Stanford Research Institute, Report 5655-502, Oct. 1977.
- 1.6 M. B. Kuhner, et al, "Applications of a High Altitude Powered Platform (HAPP)," Battelle Report BCLQATFR-77-5, Sept. 1977.
- 1.7 N. J. Mayer, H. C. Needleman, "NASA Studies of a High Altitude Powered Platform (HAPP)" AFGL-TR-79-0053, AFGL Scien. Balloon Symp., Hanscom Air Force Base, August 21-23, 1978.
- 1.8 H. C. Needleman, R. W. Weis, W. C. Brown, "Recent Studies on a Lighter-Than-Air High Altitude Platform," AIAA Lighter-Than-Air Systems Technology Conference, Annapolis, Maryland, July 8-10, 1981.
- 1.9 "User Definition and Mission Requirements for Unmanned Airborne Platforms," NASA CR 156861, Dec. 1979.
- 1.10 N. J. Mayer, "High Altitude Airships, Performance, Feasibility, Development," EASCON 1979 Conference, Oct. 11, 1979, Washington, D. C.
- 1.11 S. W. Strganac, "Wind Study for High Altitude Platform Design," NASA RP1044, December, 1979.
- 1.12 Design Definition of a Microwave Power Reception and Conversion System For Use on a High Altitude Platform. NASA Contractor Report 156866, May, 1981.

2.0 BACKGROUND DATA AND OTHER FACTORS CONSIDERED IN THE DESIGN OF THE GMPTS

The design of the ground array reflects the consideration of many diverse input factors. This section will discuss those factors in considerable detail. It may also serve as a reference section to Section 3.0 in that it will answer many questions of "why was it done this way" nature.

This section also responds to the contractual work statement, which specifies (1) a set of assumptions limiting the scope of design selection, and (2) a set of design considerations which the study should address. It responds by discussing the underlying reasons for the set of initial assumptions, and provides the technology background for addressing the specified design considerations.

The discussion in this section is organized as follows.

- 2.1 Initial assumptions specified in the work statement.
- 2.2 Design considerations imposed by the HAPP vehicle.
- 2.3 Availability of component technology for designing and constructing a system in the near-time frame.
- 2.4 Component technology, to be discussed in the following categories:
 - 2.4.1 Microwave antenna technology.
 - 2.4.2 Technology for microwave power generation and amplification, control of amplitude and phase of the microwave output, and interface with source of dc power.
 - 2.4.3 Beam steering and phasing control system.
- 2.5 Cost minimizing procedures.
- 2.6 Conversion of 60 cycle power into filtered dc power.
- 2.7 RFI/EMI considerations
- 2.8 Thermal design.
- 2.9 Mechanical design.

2.1 Assumptions Specified by the Work Statement

There were a number of assumptions listed in the work statement which limited the scope of the transmitter design and which determined major elements

of the design approach. The reason for these assumptions varied, ranging from such obvious items as a choice of wavelength to avoid the attenuation caused by heavy rainstorms, to the recognition of limitations of some of the microwave power transmission technology. These assumptions, because of their importance in determining the design are discussed below.

2.1.1 Choice of 2.45 GHz (12.26 cm) as the Frequency

It is broadly recognized that at low microwave frequencies there is virtually no attenuation of the microwave beam as it travels in a vertical direction through the atmosphere even with very bad weather conditions. On the other hand, it is recognized that at high microwave frequencies the attenuation is nearly 100% because the attenuation for a given rainfall condition varies as the 4th power of the frequency. The conclusion is that for continuous operation under all weather conditions the frequency should be under 4 GHz. ^(2.1) This conclusion is supported by Figure 2.1. The choice of 2.45 GHz as the specific frequency was heavily weighted by the fact that it is at the center of the ISM band (Industrial Scientific Medical) band which is reserved for non-communication type uses of the spectrum, such as the microwave oven, medical diathermy, etc. It is also the frequency where critical microwave components such as microwave generators are readily available at low cost.

Although a 20% higher frequency would reduce the size of the transmitting antenna by the same percent, a change to such a frequency would introduce serious perturbations into the estimated costs and construction time. Taking all things into account, 2.45 GHz appears to be an excellent compromise.

2.1.2 Power Density of the Microwave Beam Impinging Upon the Rectenna on the LTA vehicle - 175 watts/meter² Originally but Revised to 500 watts/meter²

The value of 175 watts/meter² was originally selected because it appeared that this would be a properly conservative value at which to operate the rectenna. ^(2.2) However, during a subsequent technology development of the thin film printed circuit rectenna, it was found that improvements in the efficiency and the use of an improved film material would justify a much higher value. ^(2.3)

ORIGINAL PAGE IS
OF POOR QUALITY

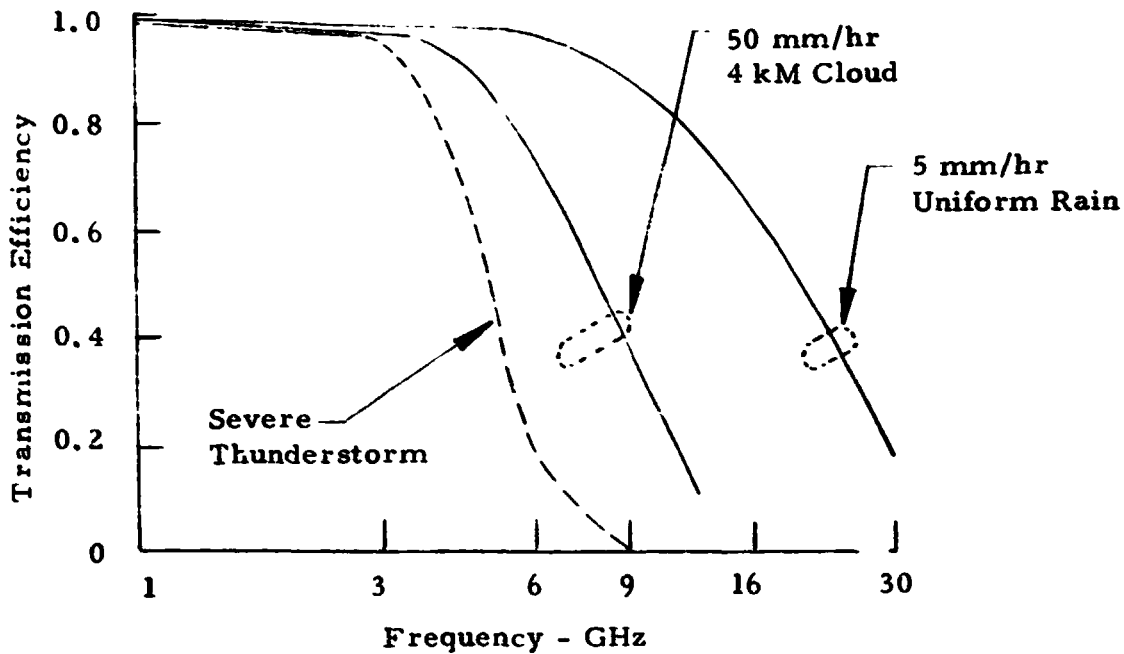

Figure 2.1 Transmission Efficiency - Molecular Absorption and Rain

From additional studies of high altitude winds it was also concluded that the HAPP vehicle should be able to cope with winds of higher speed and that as much as 200 kilowatts would be required for the highest wind speeds to be expected at an altitude of 20 kilometers (65,000 feet). But there was no place on or in the balloon to position a rectenna large enough to produce 200 kilowatts of power output if the dc power density were limited to $175 \text{ watts/meter}^2$.

It was therefore agreed that the assumption of dc power density from the rectenna would be changed from $175 \text{ watts/meter}^2$ to $400 \text{ watts/meter}^2$.

The most notable impact of this specification change upon the transmitting antenna is that it would increase the cost of it by a factor of 1.5, since the minimum cost of the antenna is proportional to the $1/2$ power of the incident power density at the reception point. (See Section 2.5.5.) Other impacts of the increased power density are minimal.

2.1.3 Linear Polarization of the Transmitting Antenna and Control of the Polarization Alignment Between the Transmitting Antenna and the Rectenna by the Rotation of the Transmitting Antenna

The major reason for assuming and specifying linear polarization was the fact that both the thin-film printed circuit rectenna as developed for the LTA HAPP^(2.2) and the transmitting-antenna radiating module as developed under contract NAS8-33157^(2.4) were both linearly polarized. The developments to convert these components to make them circularly polarized so that there would be no physical alignment problems would be long and expensive, and in the case of the rectenna would most likely invalidate the two-plane rectenna (foreplane and reflecting plane) configuration for which the thin-film, etched circuit is well suited and which is so attractive from the weight and cost point of view.

The difficulty presented by conversion to a circularly polarized format is the presence of the dc conducting busses in the foreplane which become good reflectors of the incident microwave power when the E vector is aligned with the conductors. A change to a three-level rectenna construction to accommodate circular polarization would result in a much more massive and expensive construction.

In principle it would be possible to have two separate rectennas on the HAPP LTA, with their directions of polarization oriented 90° from each other. But the high power requirements of the HAPP LTA negates this approach because of the lack of space for attaching two separate rectennas, each of which would have to be full size, since each rectenna at some time would have to handle the full power. Further, when the two rectennas were oriented at a 45° angle with respect to the ground transmitter, both would have to be simultaneously illuminated with full power from the ground to produce full output dc power. The resulting spot size of the beam would have to be large and operate at full power density. The resulting level of radiated power from the transmitter would be economically unattractive.

ORIGINAL PAGE IS
OF POOR QUALITY

It should be noted that it is possible to operate a linearly polarized rectenna from a circularly polarized beam, but the maximum capture efficiency drops to 50%.

It would appear that the best way out of this dilemma is to mechanically rotate the transmitting antenna. But there would be strong motivation to do this any way in the HAPP LTA because of the need to match the shape of the microwave beam to the elongated shape of the rectenna to retain power-transfer efficiency. The rectenna shape is effectively a long oval with the axial length about twice its width. To generate this pattern the ground transmitter has to be of approximately the same shape but with the major axis 90° with respect to that of the HAPP LTA. If the transmitter geometry is so configured, it will have to rotate if the LTA vehicle changes its heading.

Because of the generic nature of microwave power transmission, and the possible use of the GMPTS for other forms of aircraft, notably the airplane and the helicopter, it may be of interest to discuss the relationship of the ground transmitter to these other vehicles. Presumably, in the case of airplanes, the rectenna would be placed underneath the wings, and the shape of the rectenna would be even more oblong than it is in the case of the HAPP LTA. However, the airplane does not require nearly the power that the balloon does to propel it at a speed that enables it to cope with any wind speed to be expected at 20 kilometers. The airplane with a small payload of 150 kilograms would require only 20 kilowatts of power rather than 200 kilowatts. It could, therefore, operate inefficiently from a fixed transmitter of the same area and power level as the GMPTS but which could be circular in shape. In this example, a circularly polarized transmitting antenna and circularly polarized rectenna would be desirable to prevent having to rotate either the rectenna or the transmitter as the airplane changes its heading. However, in the longer range picture, it may be desirable to build much larger airplanes with correspondingly larger wing areas to support heavier payloads. The needs of the airplane and the HAPP LTA for a rotating transmitter to sustain high transmission efficiency then become very similar. Again, circular polarization would not be needed or desired.

Because the transmitting antenna will be large, questions arise with respect to its rotation: (1) can it be accelerated and decelerated rapidly enough to accommodate the flight patterns of the HAPP vehicle? (2) can it maintain its mechanical shape as it rotates, or if it distorts can this be taken into consideration by suitable means? The first question is discussed in Section 3.2.3. In summary, the mass that is involved in the transmitting antenna modules is relatively low, and if the mass of structure that support them can be held to within a factor of two or three times that of the modules, then the moment of inertia of the structure can be held within reasonable bounds. With the modest demands from the turning vehicle for angular acceleration of the transmitting antenna, the power requirements for acceleration and the braking requirement for slowing the antenna rotation will be modest.

The second question can be answered in the affirmative if the rotating antenna is supported by rolling it on rails whose height can be accurately adjusted with precise surveying and levelling techniques.

The helicopter, as contrasted to the airplane and the HAPP LTA, does not have a polarization problem and it has other advantages. It can keep directly above the transmitter, which allows larger radiating modules to help reduce the cost of the antenna and it could simplify the launch and retrieval complexity by being able to take off and land on a pad directly above the antenna. However, in its conventional format, it has a very severe limitation on the amount of lift that can be achieved from a given amount of received power as compared with the airplane, and the drag of an ancillary antenna, while quite acceptable at 20 kilometers, is likely to be excessive as it traverses the high winds with comparatively high air densities in the 6 to 10 kilometer region.

2.1.4 The Vehicle Shall Always Be in the 3 dB Antenna Beamwidth of the Ground Antenna

This provision could read as either a constraint upon vehicle design or upon the transmitter design. From a practical point of view, it is a joint restraint. The vehicle excursion, as measured from a vertical line passing

through the center of the transmitter, should be as little as possible. But there will be a lower limit in the case of the HAPP LTA, and this excursion is then passed on as a constraint upon the transmitter design.

The constraint placed upon the transmitting antenna concerns the size of the radiating module. Figure 2.2 shows the decrease in the intensity of the beam as a function of off-axis pointing and as a function of the side dimension of the radiating module. As the size of the module is increased, the degradation of the beam to off-axis pointing increases rapidly. On the other hand, the cost of the transmitting array rapidly increases as the size of the radiating module decreases. This is because the number of radiating modules in the total array is inversely proportional to the square of the side dimension of the radiating module. Because the cost of the components to change the phase of each array element is substantial, the cost of these components for the total array becomes a major element of cost as the dimensions of the radiating module become small. This is discussed further in Section 2.5.2.

The data shown in Figure 2.2. is generated by a consideration that the antenna pattern (normalized to unity at $\theta = 0$) as given by one of the individual modules is

$$g \theta = \frac{\sin \left(\frac{\pi l}{\lambda} \sin \theta \right)}{\frac{\pi l}{\lambda} \sin \theta}$$

where l = side dimension of radiating module

λ = wavelength

θ = off-axis angle (See Figure 2.15.)

ORIGINAL PAGE IS
OF POOR QUALITY

ORIGINAL PAGE IS
OF POOR QUALITY

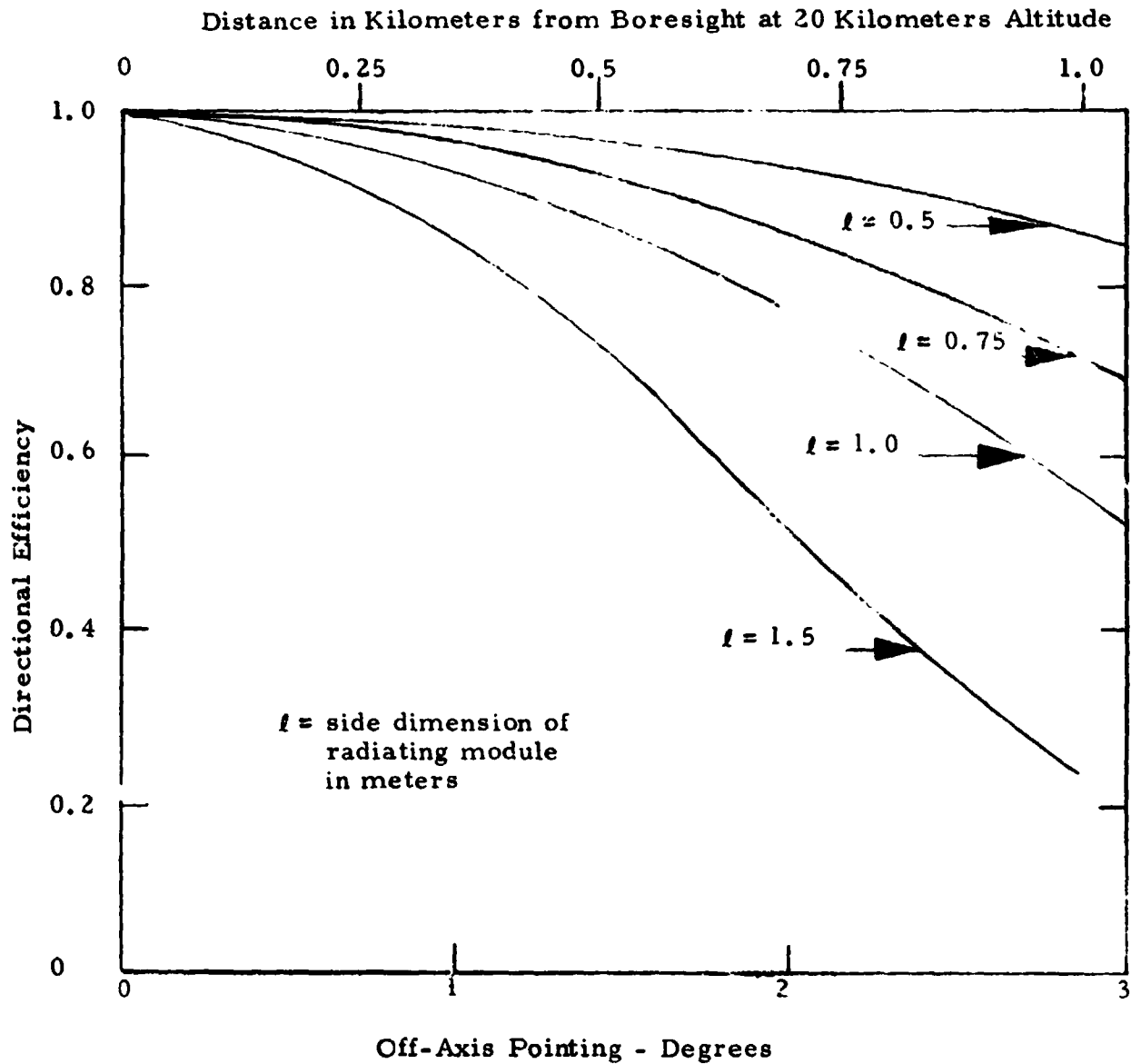

Figure 2.2 Decrease in the Density of the Microwave Beam
as a Function of Off-Axis Pointing

The power density is proportional to the square of $g(\theta)$. Figure 2.2 follows this relationship:

In Section 2.2 it is estimated that the circling flight of the HAPP LTA can be contained within a diameter of 1.5 kilometers. The side dimension of the radiating module selected for the conceptual design of the transmitting antenna is 0.75 meter. Figure 2.2 indicates that for that size module and an off-axis pointing corresponding to a flight radius of 0.75 kilometer, the beam power density will be 0.84 of the on-axis intensity. The loss of 16% or 0.075 dB is well within the 3 dB loss specified but nevertheless represents a significant decrease in power. The power loss of 16% can be compensated for by an increase in the cost of the transmitting antenna by about 8%.

2.2 Design Considerations Imposed Upon the GMPTS by the Design of the LTA HAPP Vehicle and Its Flight Characteristics

Three aspects of the design of the LTA HAPP vehicle and its flight characteristics have considerable impact upon the design of the GMPTS. These are (1) the high peak power requirements of the LTA HAPP vehicle, (2) assignment of the rectenna to a specific area of the balloon, and (3) flight characteristics of the LTA HAPP vehicle. A discussion of the impact of these aspects follows:

2.2.1 Impact of the High Peak Power Requirements of the LTA HAPP Vehicle Upon GMPTS Design

Subsequent to the activation of contractual study on the GMPTS but in accord with the intent to make changes in the initial assumptions if found to be necessary, the maximum power requirement of the LTA was raised to 200 kilowatts of dc power to supply propulsive power to compensate for the greatly increased drag associated with very high wind-speed peaks of 95 knots that were found to exist infrequently at some geographical locations. The rectenna's ability to handle power density was raised to 400 watts of dc power output per square meter.

This increase in total power and power density requirements has had considerable impact upon the GMPTS design and its cost. First, the initial cost has gone up in proportion to the one-half power of the increase in microwave power density at the rectenna. However, the average power demanded from the transmitter has gone up very little because the high peak winds occur for only a small proportion (less than 1%) of the total time.

In its investigation of the average propulsive power required to counteract the drag of the wind on the LTA HAPP vehicle over a period of a year and sampling many locations in the continental United States, ILC Dover found this figure to be four kilowatts. This corresponds to about five kilowatts out of the rectenna on the vehicle. Yet this same rectenna has to supply as much as 200 kilowatts of power under unusual and rare circumstances.

ORIGINAL PAGE IS
OF POOR QUALITY

This situation is shown graphically in Figure 2.3 where the power requirement from the rectenna is plotted against percentage of elapsed time. The fraction of time that any interval of power exists may be found by extending that interval horizontally on the chart, noting the two points where the interval intersects the curve, and then reading of the interval of percentage of time on the horizontal scale. Without expanded scales on the graphs this is difficult to do graphically, and the purpose of the figure is to indicate the very large variation in power requirements that exists.

An additional impact of the increased peak power requirements for the GMPTS then is that it must contend with a much larger range of power. In effect, this has resulted in not having to use the final power stage in the amplifier chain more than about 20% of the time, and then in using it most of the time at a low value of gain. Fortunately, the basic design of the transmitter can contend with that arrangement in a satisfactory manner.

For many geographical regions the peak wind velocities of 95 knots do not exist and so the GMPTS designed in this study may be considerably over designed for some geographical areas.

2.2.2 Impact of the Assignment of the Rectenna to a Specific Area of the LTA HAPP Upon GMPTS Design

As the result of the greatly increased power requirements for the LTA, and even though the rectenna dc power density has been increased to 400 watts/meter², the required rectenna area has had to be increased to a projected area of 500 square meters. The only available area that is part of the natural streamlined configuration of the LTA is along its undersurface, and there the resulting configuration of the rectenna is an elongated oval, approximately twice as long as it is wide. The impact of this upon the design of the GMPTS is to configure the transmitting antenna to a similar geometry to maximize the power transfer efficiency. The resulting GMPTS configuration is a rectangle, twice as long as it is wide.

ORIGINAL PAGE IS
OF POOR QUALITY

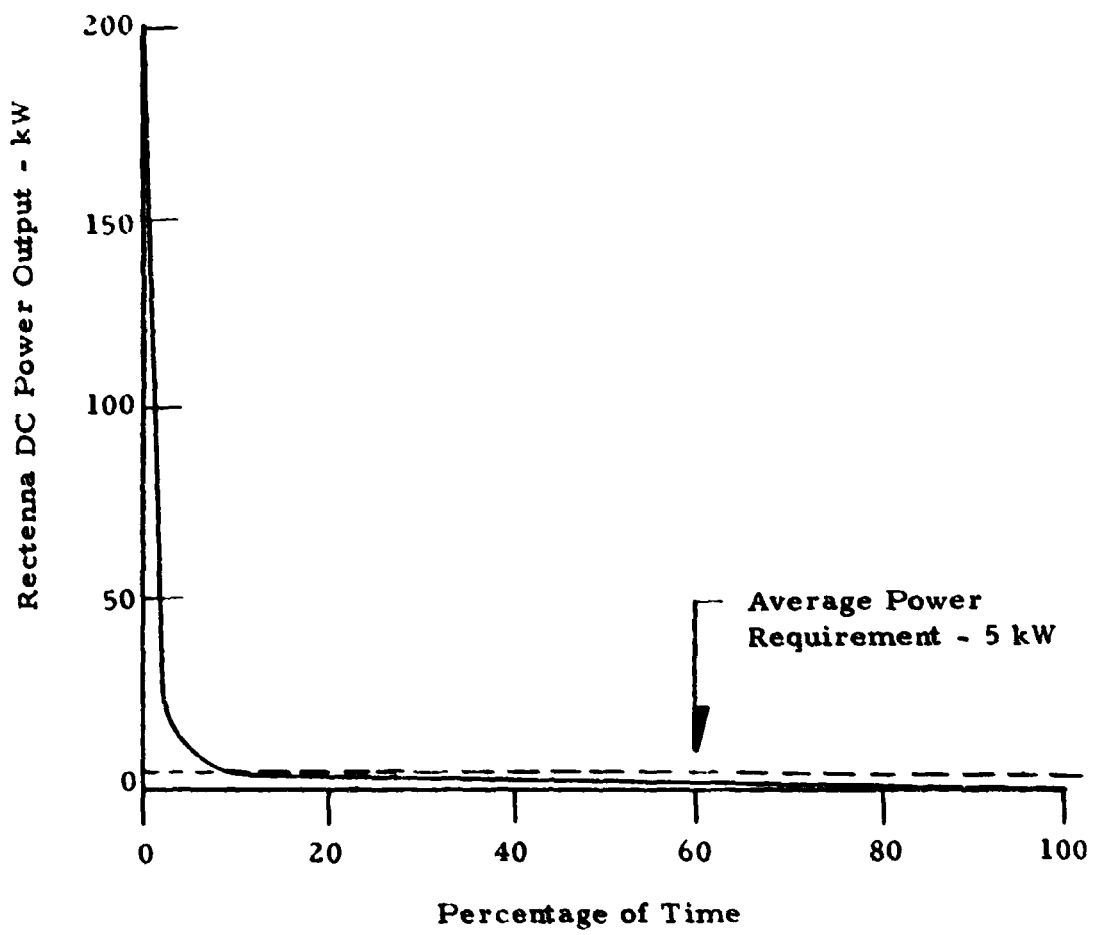

Figure 2.3 LTA-HAPP Power Requirements as % of Total Operating Time

The large area of rectenna required also effectively eliminated a potential solution to the maintenance of polarization alignment without having to rotate the transmitting antenna. The solution that had been examined was two separate rectennas, one behind the other on the balloon's undersurface and with their polarization directions at right angles to each other.

2.2.3 Impact of the Flight Characteristics of the LTA Upon GMPT^c Design

Studies of the effects of daytime heating and night time cooling of the LTA indicated first that it would be necessary to move the LTA in circular flight to enable it to develop positive lift at night and negative lift in the daytime. More recently, it has been found that aluminizing the fabric of the balloon and other modifications will minimize the diurnal problem, so that circular flight may no longer be necessary, or if it is necessary, so that it can be made at slow speed and in a comparatively small diameter. The LTA, of course, has to remain pointed into the wind if it is not circling. Currently, these changes in direction are made by changing the thrust vector of the tail motor which is mounted on a swivel post.

The space required to effect these lifting operations if they are necessary and the maneuvering operations to turn into the wind when not circling are very important in determining the cost of the array as discussed in Section 2.1.4 and Section 2.5.5. However, the space required to accommodate these flight functions has not been clearly defined. From the viewpoint of maneuvering, it is known that the wind changes direction and speed at that altitude very slowly, and it is also known that the response time of the vehicle to a step function of drag may be of the order of a minute. Presumably, this would be considerably faster than any change in the slope of the wind speed change (second derivation of wind speed) so that the control loop should be straightforward and stable.

It is possible that an optimization of the vehicle design to minimize need for auxiliary lift and to give it an ability to turn about its vertical axis without displacing that axis appreciably would allow it to confine itself within a very small circle. In the meantime, it is the consensus that the vehicle can remain within

a diameter of 1.5 kilometer, and that has been the basis of the proposed transmitting antenna design.

2.3 Availability of Component Technology for Design and Construction of a System in the Near-Time Frame

It is stated in the Work Statement that the design shall include state-of-the-art hardware and procedure where possible, but that new technology is acceptable if it is considered feasible within one year of design completion. This statement reflects the desire to be able to complete the detailed design of the transmitter and to fabricate it without appreciable delay caused by having to develop some of the components. This provision has been adhered to in the conceptual design study, but it does not exert a hardship upon the design because the desirable components and design procedures are readily available.

These state-of-the-art components and procedures will be discussed more fully in Section 2.4, but it may be worthwhile to point out how fortuitous it is that some of them do exist. Perhaps the most fortuitous item is the microwave generator in the form of the microwave oven magnetron, which has all of the qualifications needed, including low cost and long life, for this application. If such a tube did not exist, it would be necessary to consider the long delay occasioned by new tube developments and the uncertainty of predicting their performance after development.

It is also fortuitous that the conceptual design and subsequent construction and testing of the radiating module has been accomplished. Such testing assures us of the ability of the unit to follow both a phase and amplitude reference, and the electrical stability of the interface of the magnetron directional amplifier with the slotted waveguide radiator, etc. For this module, a new method of fabricating a low-cost slotted waveguide radiator was developed and tested.

**ORIGINAL PAGE IS
OF POOR QUALITY**

2.4 Background of Component and System Technology From Which GMPTS Conceptual Design Was Selected

The conceptual design of the GMPTS has been established after review of the applicable background of component and system technology. This background will be discussed under three groupings:

- (a) Microwave antenna technology.
- (b) Technology for microwave power generation and amplification, control of amplitude of the microwave output, and interface with source of dc power.
- (c) Beam steering and phase control technology.

2.4.1 Microwave Antenna Technology

The purpose of this section is to discuss microwave antenna technology in general terms and then to specifically address the kind of antenna selected for the conceptual design of the GMPTS. This section will not address the subject of beam focussing and steering of the active phased array which is the subject of Section 2.4.3.

2.4.1.1 Discussion of Various Antenna Approaches

During the early part of this proposal, a number of different approaches to designing the transmitting antenna were examined. One obvious approach was a parabolic reflector, modified in this case to an ellipsoidal reflector, illuminated from a point source by a high powered microwave generator. From the viewpoint of a near term demonstration of a microwave powered air vehicle at a high altitude of 20 kilometers, the installation at Arecibo in Puerto Rico and the Mars transmitter at the Goldstone facility of JPL could be used to good advantage.

The Arecibo installation has a 420-kilowatt source of CW power at 2380 MHz and an effective aperture diameter of 700 feet. This would provide an illumination of 2360 watts per square meter on a vehicle flying in a fixed position at 20 kilometers, and for that matter 23.6 watts per square meter on a space craft at a distance of 200 kilometers from the earth.

The Mars transmitting antenna at Goldstone has a 67-meter diameter aperture with a nearly identical source of CW power. With an aperture illumination efficiency of 67%, it would provide an illumination of 233 watts per square meter on a vehicle flying at 20 kilometers.

But aside from the value of these installations from a demonstration point of view, they do not appear to be cost effective in their present format in the type of application for which the microwave powered vehicle is being considered. The Arecibo installation is unique in that it takes advantage of an unusual geological configuration in the earth's surface. It is also much larger than is necessary. The Mars installation comes very close to being able to supply the 500 watts of incident microwave power now being used as the design criteria for the LTA HAPP vehicle. It has, however, a mechanical arrangement for steering the beam and in its present form would be much too expensive.

A much more tractable approach is to adapt the reflector approach to the GMPTS by eliminating the mechanical steering of the large reflector and to mechanically change the position of the feed horn.

The contractual support for this study was not sufficient to investigate the details of what would be involved in adapting the technology as exemplified in the Mars transmitter to the GMPTS. A principle argument made for the active phased array approach, as applied to the high altitude vehicle, is that it appeared to be more cost effective, basically because of the modular approach that employed low cost components and technology. The modular approach takes advantage of the economics to be achieved by mass production, and it also allows the relatively straightforward expansion of an existing facility while the reflector installation does not. Expansion, in terms of an orderly procedure in the development of the first prototype, or in subsequent modification of an existing commercial facility, is considered to be an important aspect.

In concluding this general discussion, the author believes that since it is difficult to predict the circumstances under which the high altitude microwave

powered vehicle will come into existence as an operating entity, it is impossible to rule out the conventional parabolic reflector with its associated conventional illumination from a high power point source. For example, if a national emergency should come into being and whose exigencies could be served by a microwave powered platform, a proven installation such as the Mars facility could serve as a prototype and would probably be made use of in that format. Using the limited resources of this study to concentrate on the conceptual design of a phased array transmitter specifically for a microwave powered high altitude vehicle has significantly advanced an understanding of what is involved in that approach and in preparing for the next step of a logical development program for such a transmitter.

2.4.1.2 Technology for the Radiating Module

The format for the radiating element in a conventional phased array used for radar purposes is a single dipole or the open end of a single section of waveguide. To minimize the cost of the phase control electronics in the GMPTS, it is essential that many of these radiating elements be grouped together. Under these circumstances, the radiating module with a much larger aperture can take a more complex form. For example, it could be the end of a rectangular horn, or a helical coil, or a lens.

Fortunately, it was not necessary to compare these various approaches because this had already been done in the investigations that took place in connection with the Solar Power Satellite study.^(2.1) That study concluded that the slotted waveguide array was much superior electrically because its radiation efficiency approached 100% as compared with low efficiency for the other approaches, 70% for a rectangular horn, for example.

2.4.1.3 Method for Fabricating Low-Cost Slotted Waveguide Modules from Thin Gauge Aluminum Sheet

It was also known prior to this study that a new low cost method had been worked out for the fabrication of slotted waveguide arrays from relatively thin

gauge aluminum sheet.^{2.6} Arrays made with this technique were checked out on the JPL antenna range and found to have acceptable patterns. In fact, a major advantage of the fabrication method is that close mechanical tolerances can be held to provide reproducible electrical performance.

The specific arrays made for JPL were designed for 2.45 GHz frequency and are directly applicable to the GMPTS. Their side dimension is 0.75 meter, which seems to be also the best compromise in the size of the radiating module for the GMPTS design.

The slotted waveguide array, as shown in Figure 2.4, consists basically of a folded top plate whose corrugations contribute the three sides of the waveguide and a bottom plate into which the radiating slots are punched. The two sections then flow together and are joined to each other by resistance spot welding or by laser beam welding to form the finished assembly shown in Figure 2.4.

The holes which are punched into the material are spaced accurately from each other and serve to accurately locate the material in the bending fixture which is also accurately machined and ground. The holes also serve to jig the top and bottom halves to each other for accurate assembly.

The individual slotted waveguides in the array are fed from a feed waveguide shown in Figure 2.5 as the transverse waveguide. Transfer of energy is made through diagonal slots between the feed waveguide and radiating waveguides. A front view of the configuration is shown in Figure 2.6. The radiating module has 64 slots in it and the output phase of all of these slots is uniform (within the tolerances prescribed) and determined by one set of phase control electronics rather than 64 as in a conventional phased array.

The H-plane antenna pattern, taken at the antenna range of the Jet Propulsion Laboratory, is shown in Figure 2.7. This and the E-plane pattern were considered to be good patterns. However, the edge effects of such a structure degrade the pattern from what it would be if identical arrays were contiguous to each other.

ORIGINAL PAGE IS
OF POOR QUALITY

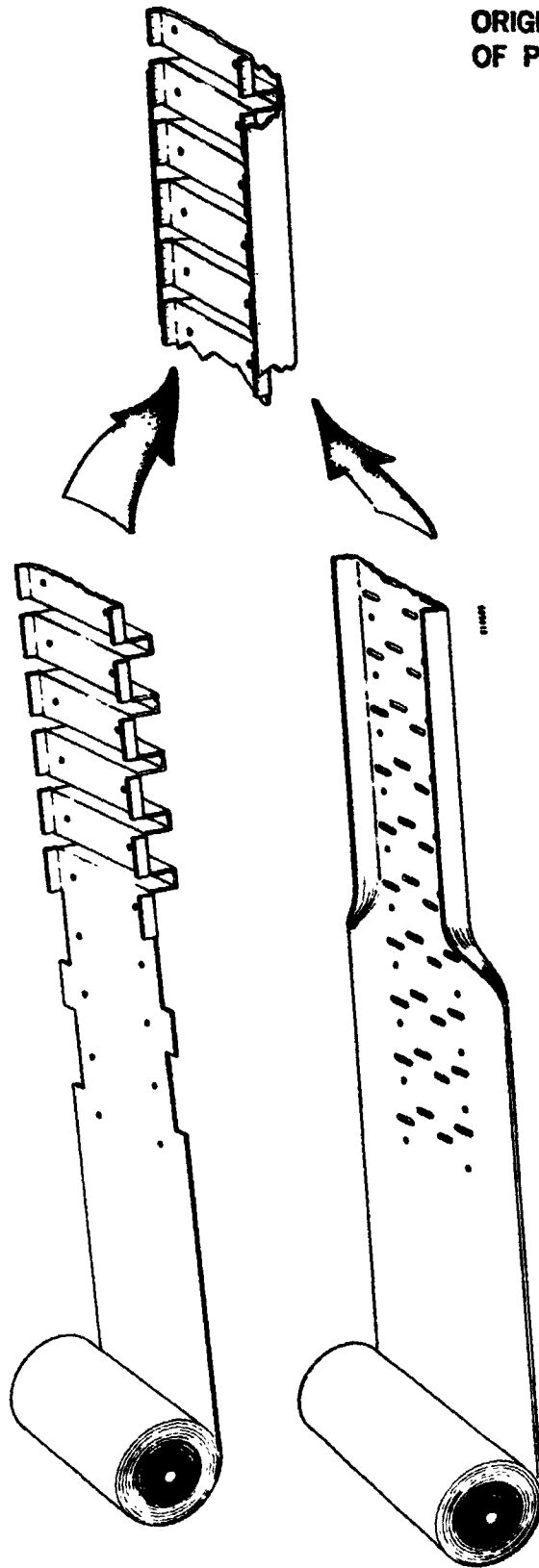

Figure 2.4 Method for Precision Forming and Assembly of Low-Cost,
Thin-Walled, Slotted Waveguide Radiating Modules

ORIGINAL PAGE IS
OF POOR QUALITY

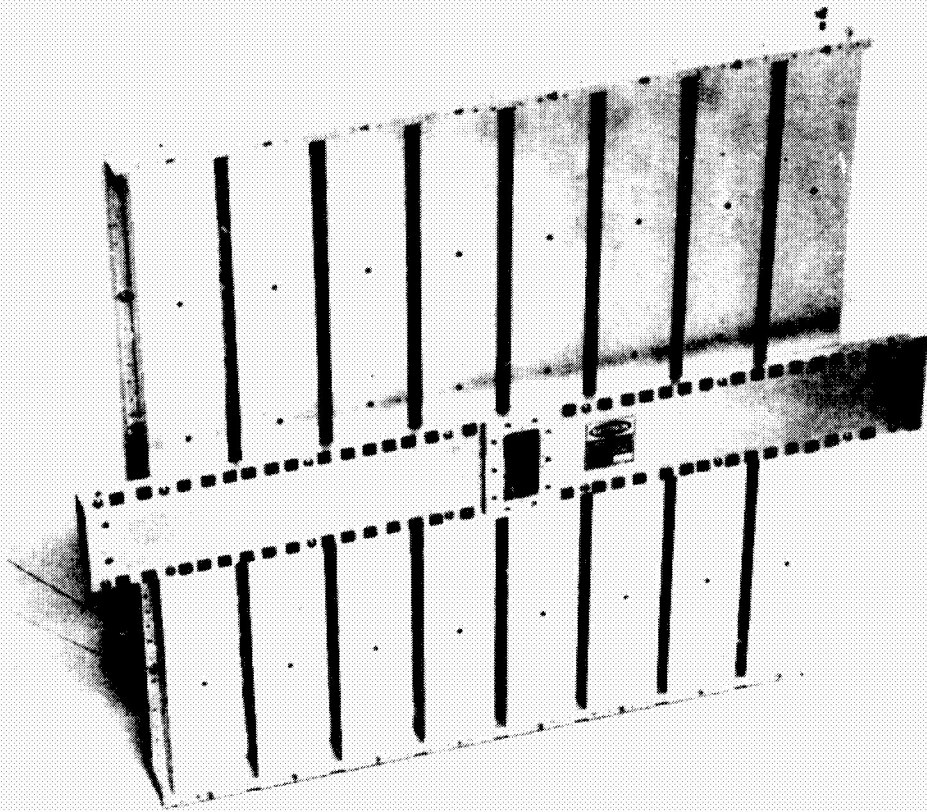

Figure 2.5 Back View of the 8 x 8 (8 Slots in Each of 8 Waveguides)
Slotted Waveguide Array as Constructed from 0.020
Inch Aluminum Sheet Throughout and Assembled by
Means of Spot Welding

ORIGINAL PAGE IS
OF POOR QUALITY

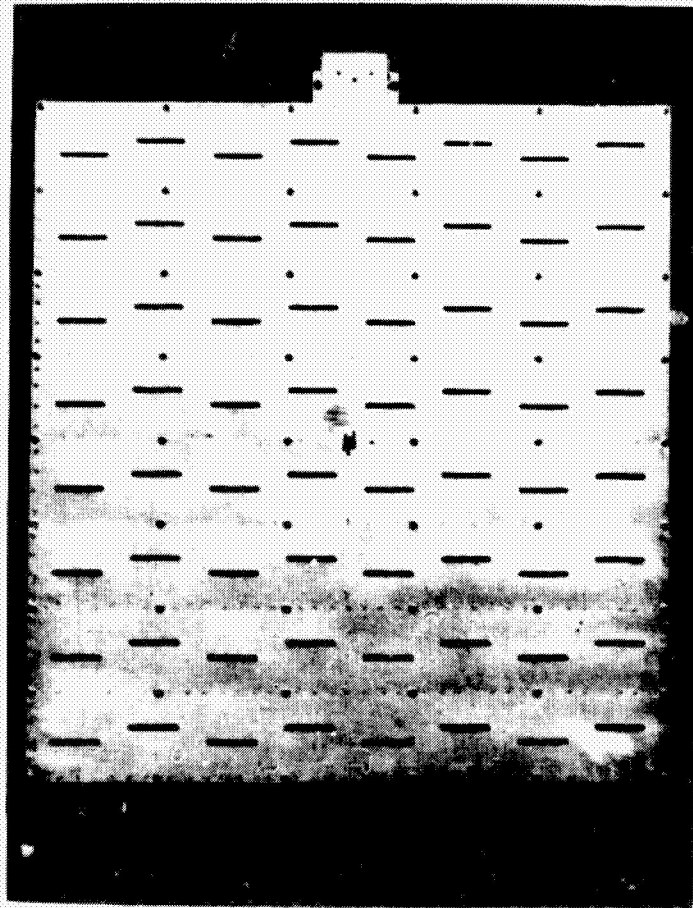

Figure 2.6 Front View of the 8 x 8 Slotted Waveguide Array

ORIGINAL PAGE IS
OF POOR QUALITY

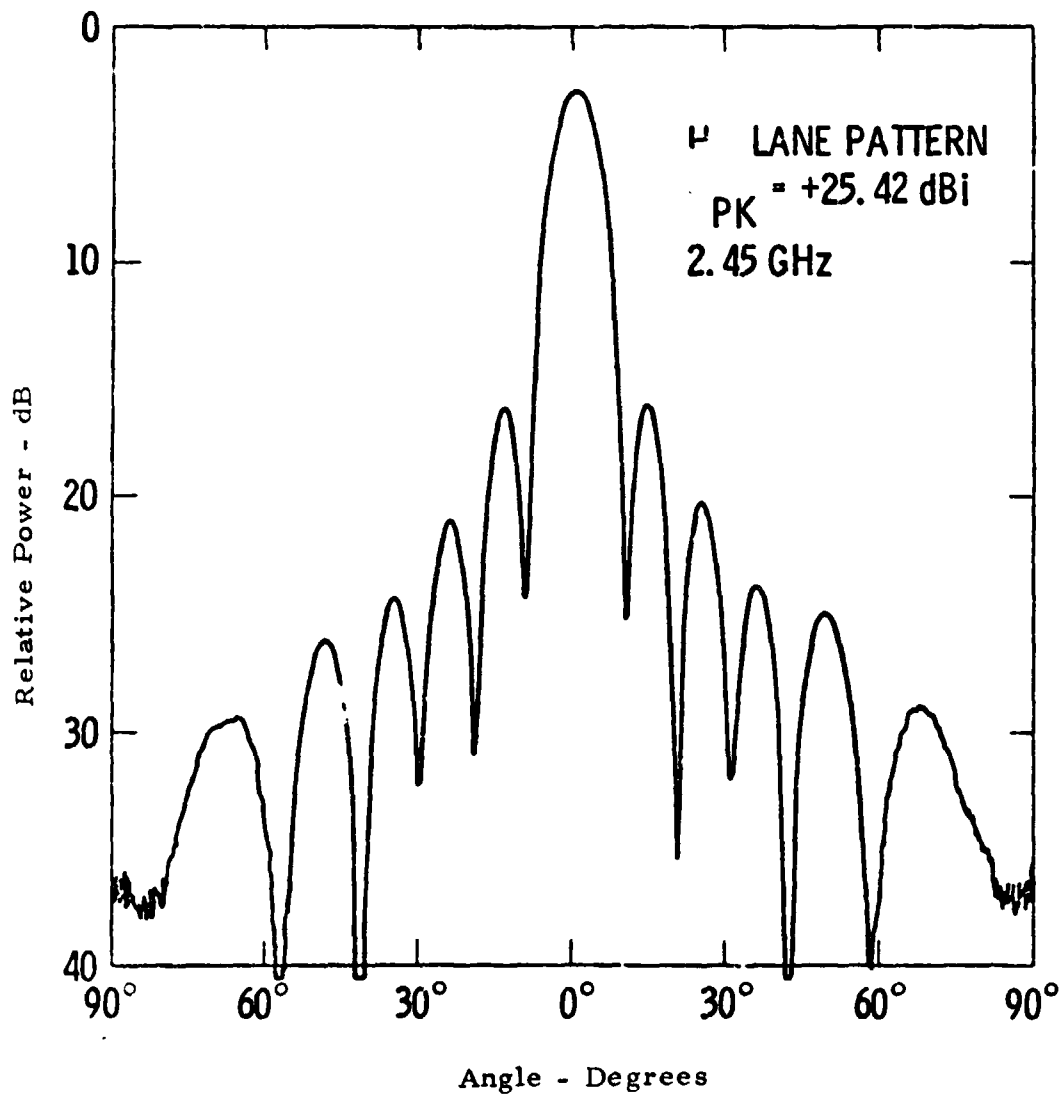

Figure 2.7 Antenna Pattern for 64 Slot Radiating Module
that is Directly Applicable to the
GMPTS Requirements

One of the outstanding advantages of this structure is the relatively small amount of aluminum used in it, which implies both weight and cost advantages. The complete structure, as shown, weighs 2.6 kilograms. This corresponds to a weight of 4.6 kilograms per square meter of array area, so that the amount of aluminum in the complete transmitting antenna is less than 14,000 kilograms. At current costs of \$2.00 a pound for thin gauge aluminum, the corresponding material cost is less than \$60,000 for the GMBTS.

The structure, because of its box like construction, is also exceptionally strong, and more than adequately sturdy for the intended application. For example, a knife edge load of 80 kilograms along the center of the antenna module shown in Figure 2.5 and supported at two edges caused a deflection of only one millimeter at the center. (2.6)

2.4.2 Technology for Microwave Power Generation and Amplification, Control of Amplitude and Phase of Microwave Output, and Interface with the Source of D. C. Power

2.4.2.1 General Discussion

The technology grouped together in the above title is the outgrowth of an assessment of the potential role of the magnetron in the Solar Power Satellite concept and is described in reference 2.4. The technology is backed up by extensive experimental verification as described in that reference and in reference 2.6. In addition to the subjects included in the title of this section, these experimental investigations also examined extensively the signal to noise ratio and the potential life of the microwave generator.

The procedure that was followed in the assessment of the magnetron as a potential candidate for the generator in the SPS was to convert the magnetron, which is normally a free running oscillator, into a directional amplifier by adding a passive directional device in the form of a ferrite circulator. To this directional amplifier were then added feedback control loops which controlled the phase

and amplitude of the output so that they tracked phase and amplitude references. Then it was shown that the amplitude control feature also permitted the microwave generators to be operated in parallel from a common bus with no more power conditioning interface than a small resistor and a high voltage fuse, even though the voltage level of the bus was varying over a wide range.

The basic circuit arrangement of the magnetron directional amplifier and its amplitude and phase control loops is shown in Figure 2.8. How well this arrangement works is illustrated in Figure 2.9. This figure illustrates how well the level of microwave power output is controlled despite wide variations in the voltage level of the power supply when only a 100 ohm resistor is inserted between the power supply and the magnetron directional amplifier. (Such a resistor dissipates less than 1% of the power going into the microwave generator.) In Figure 2.9 the heavy lines, running diagonally downward from left to right, show how the magnetron directional amplifier reacts to a change in power supply voltage when the amplitude control reference is set at a specific value. For example, when the amplitude reference is set at 700 watts and the power supply voltage is varied from 3500 to 4500 volts, the microwave power output varies only from 687 watts to 716 watts or less than $\pm 3\%$.

As suggested in the schematic of Figure 2.8, the amplitude control of the output of the magnetron directional amplifier is made possible by the buck boost coil, which adds or subtracts to the residual magnetic field established by the permanent magnets which are part of the magnetron package. In effect, the value of the magnetic field controls the flow of current into the magnetron and therefore the microwave power output.

It is proposed that this amplitude control arrangement be used almost directly on the GMPTS. One of the special projects of this study has been to examine what would be involved in retrofitting a conventional microwave oven magnetron with a buck boost coil that would be an integral part of the magnetron package. Figure 2.10 illustrates the results of this study. It has been found that the top plate on the magnetron package can be removed and that there is room for the insertion of a small but adequate buck boost coil. Then the top

ORIGINAL PAGE IS
OF POOR QUALITY

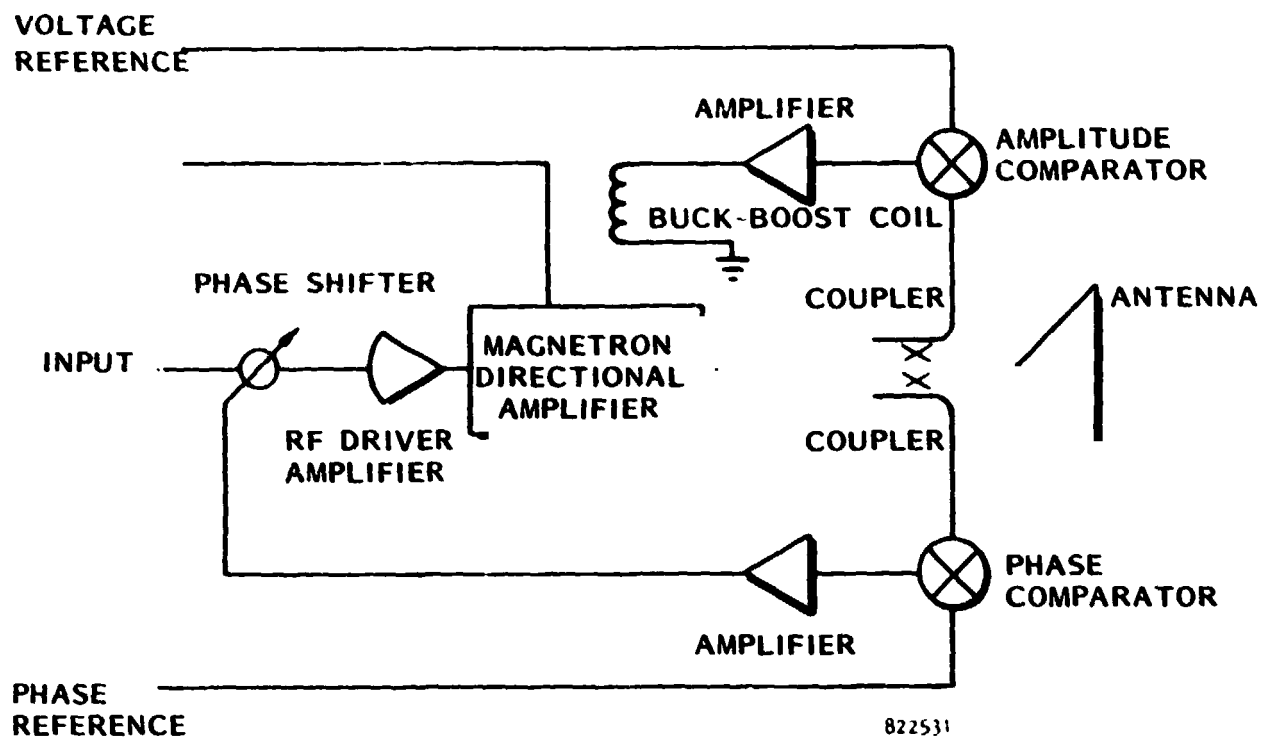

Figure 2.8 Schematic Showing how the Phase and the Amplitude of the Magnetron Directional Amplifier Output are controlled by Phase and Amplitude References and Feedback Control Loops

ORIGINAL PAGE IS
OF POOR QUALITY

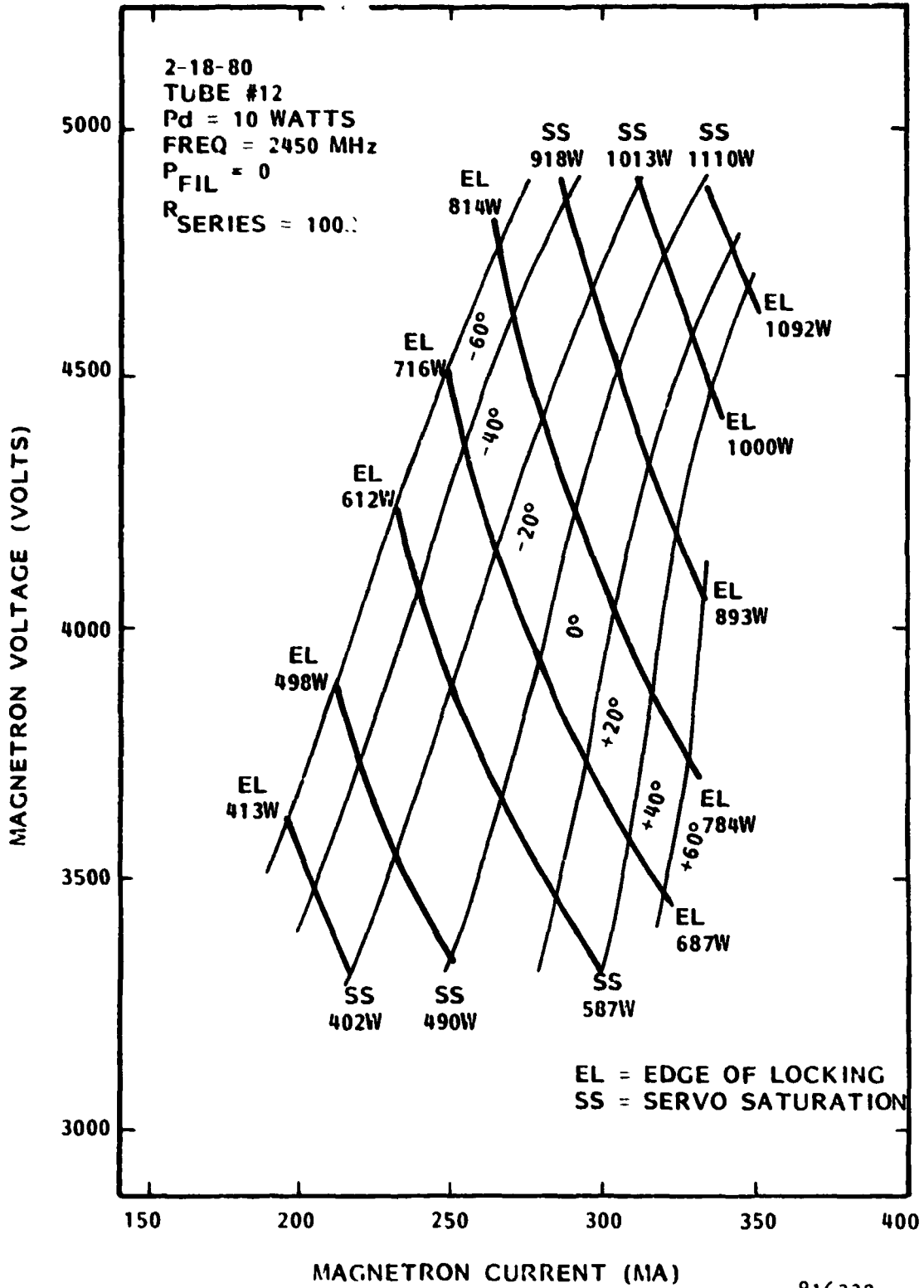

Figure 2.9 Amplitude Tracking Data with Series Resistance of 100 ohms to Simulate Operation from a Hard Voltage Bus

ORIGINAL PAGE IS
OF POOR QUALITY

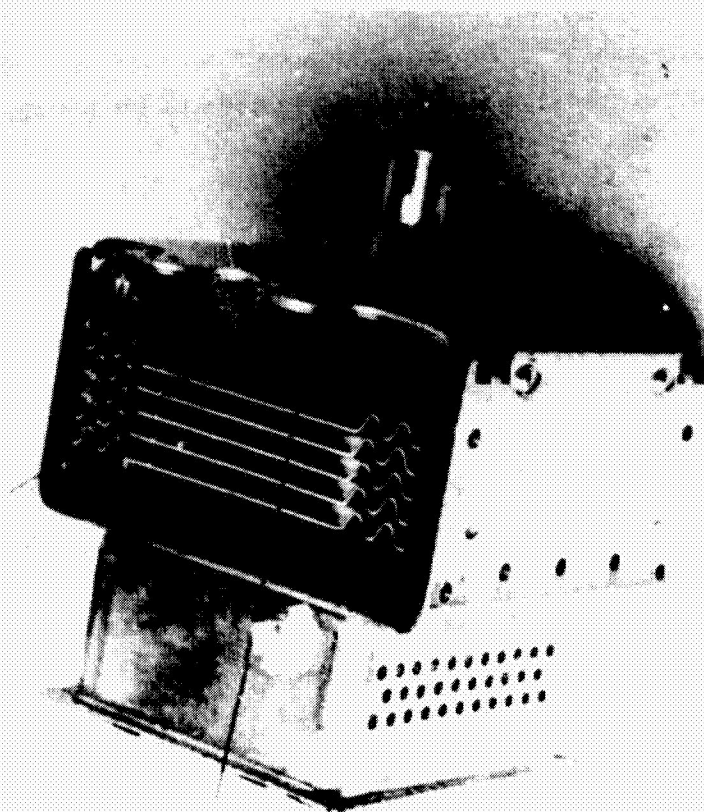

Figure 2.10 Conventional Microwave Oven Magnetron That Has Been Modified by the Addition of a Buck-Boost Coil

plate is replaced with the resulting appearance in Figure 2.10.

The characteristics of the tube with this coil is examined further in Section 4.0. It is important to note that the response time of the control circuit is very fast, which means that the amplitude control circuitry can function also to reduce the amount of passive filtering that needs to be added to the source of dc power.

Figure 2.9 can also be used to examine what is happening to the phase shift within the magnetron directional amplifier itself as the voltage and current through it is varied. This phase shift that is taking place is largely the result of what would be a change in frequency of operation of the magnetron if the drive power were completely removed and it were allowed to run as an oscillator. The phase shift through the device is theoretically and experimentally observed to be proportional to the difference between the drive frequency and the natural frequency of oscillation of the tube at that particular point of voltage and current. But it is also inversely proportional to the one-half power of the drive signal. The data of Figure 2.9 was taken with a drive power of only 10 watts. If the drive power had been forty watts, the range of current over which the tube operated would have been much greater.

In the experimental work with the magnetron directional amplifier, the phase shift through the magnetron directional amplifier was compensated for by a phase shifter shown in Figure 2.8 to be on the input side of the amplifier. The phase shifter was part of a feedback control loop that kept the phase of the output locked to the phase reference within about one degree. In the GMPTS, because one magnetron directional amplifier supplies power to four radiating modules whose emitted phase must be individually controlled, the arrangement is different.

In concluding this discussion, it should be pointed out that the concept of the magnetron directional amplifier as a combination of a magnetron and a passive directional device such as the ferrite circulator is not a new concept. Rather, its theory has been well established (2.7). The general principle is often used in connection with solid state amplifiers. The arrangement of magnetron and

ferrite circulator to form the directional amplifier is shown in Figure 2.11. In the application of this arrangement to the GMPTS, both the magnetron and the ferrite circulator are readily available and at very low cost.

ORIGINAL PAGE IS
OF POOR QUALITY

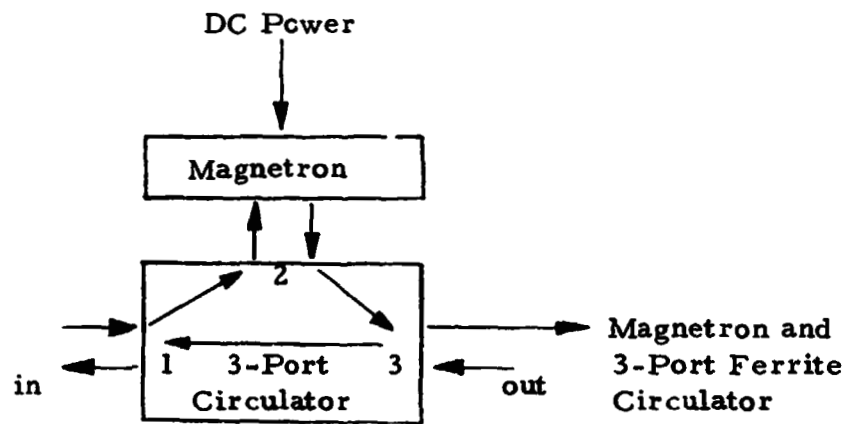

Figure 2.11 Schematic Diagram Indicating the Principle of the Magnetron Directional Amplifier

2.4.2.2 Potential Long Life of the Magnetron in the GMPTS

The life of a microwave electron tube is characteristically limited by the life of the cathode, which in turn is associated with its operating temperature, a lower temperature being associated with longer life. Fortunately, the life of the magnetron in the GMPTS application is potentially very long because of a self regulating cathode temperature mechanism which allows the cathode to operate at the low temperatures that are associated with long life while still providing the electron emission needed for the generation of microwave power.

Based upon experimental observations of the cathode temperature as a function of the anode current which in turn is proportional to microwave power output, and well understood properties of the life of the carburized thoriated tungsten cathode as a function of both temperature and depth of the carburization, the expected life of the microwave oven magnetron as a function of power output has been prepared and presented in Figure 2.12. The corresponding operating temperature of the cathode for several values of life and power output are also shown on Figure 2.12. It is clear that the life is highly dependent upon temperature---a difference of 200°K makes a difference of approximately 100 to 1 in life. Because of the critical dependence of life upon cathode temperature, it is fortuitous that there is an internal mechanism inside of the magnetron that regulates the cathode temperature. This regulating mechanism is clearly shown in Figure 2.13 where the observed temperature as a function of anode current (the power output is proportional to anode current) is shown. Superimposed upon this experimental curve is the Richardson-Dushman equation for temperature limited emission as a function of temperature. The slope of the predicted and experimental curves is very nearly the same.

ORIGINAL PAGE IS
OF POOR QUALITY

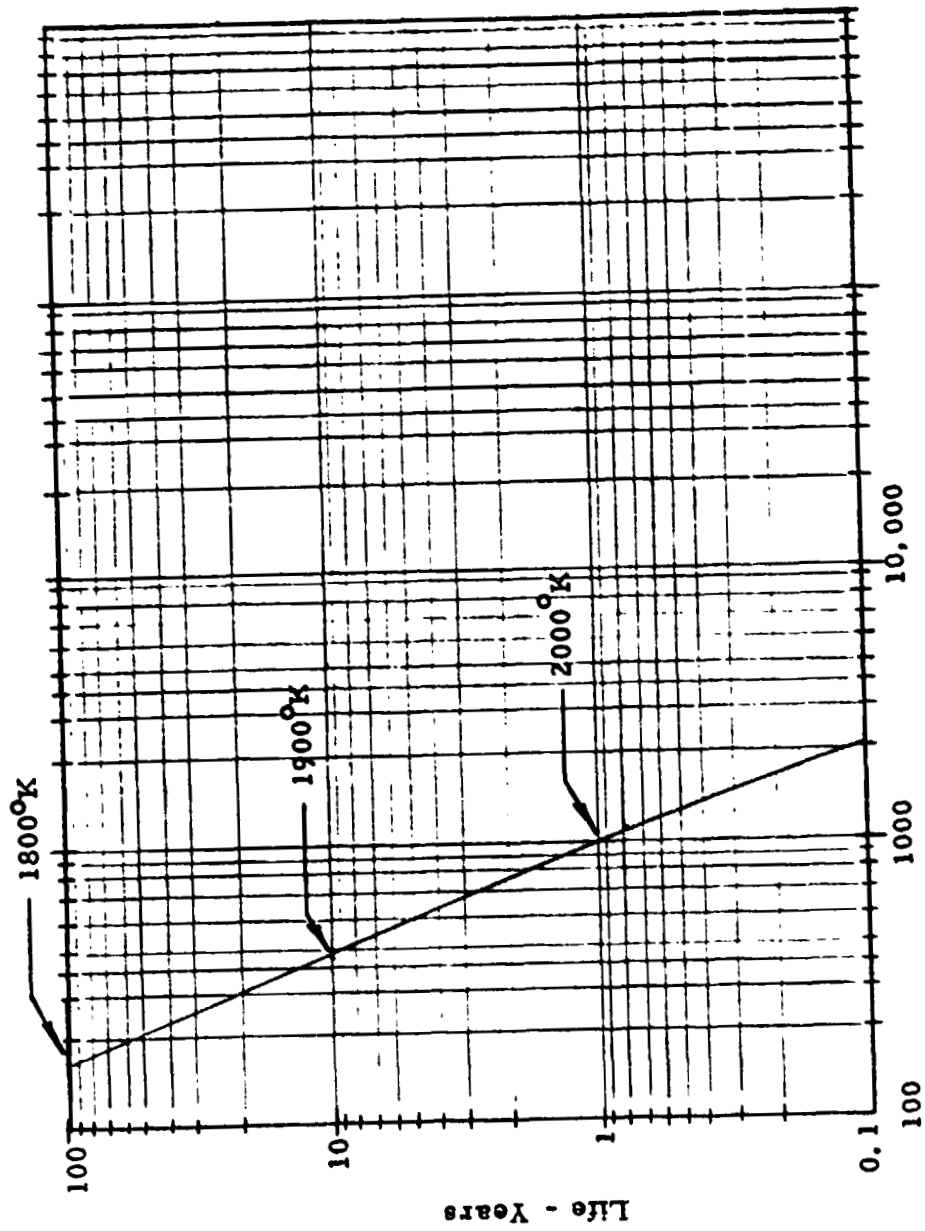

Microwave Power Output - Watts
Figure 2.12 Life of the Microwave Oven Magnetron as a Function of Microwave
Power Output. Shown also are the Filament Temperatures at
Three Operating Points

ORIGINAL PAGE IS
OF POOR QUALITY

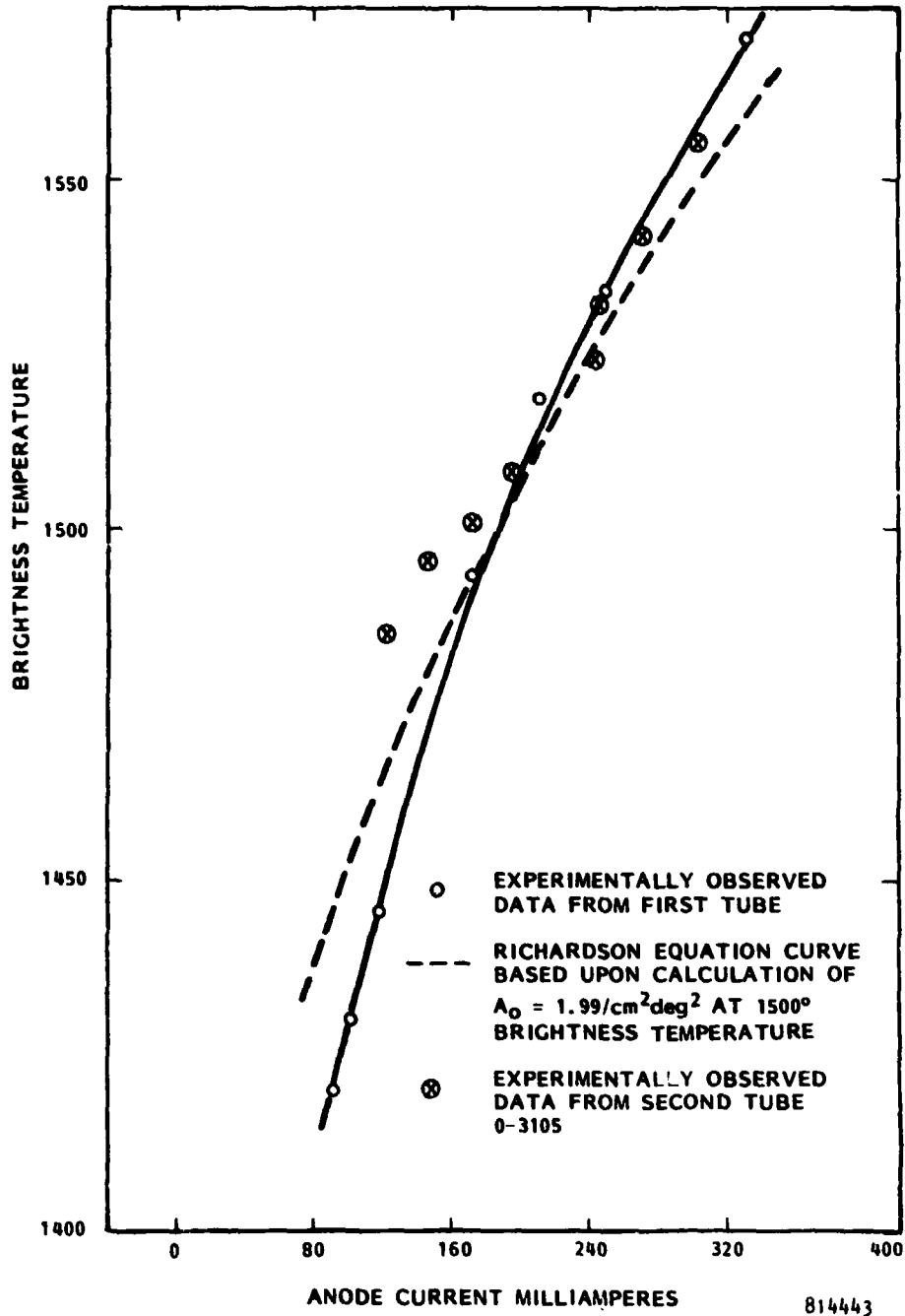

Figure 2.13 Experimentally Observed and Theoretically Predicted Relationship Between Cathode Temperature and Anode Current for Two Magnetrons with Optical Windows for Viewing Cathode Temperature

2.4.3 Beam Steering and Phasing Control System

Targeting the microwave beam on the rectenna is a primary requirement jointly imposed upon the microwave power transmission system and the vehicle. There are two primary ways to approach this problem. The first is to make the vehicle captive to the microwave beam---that is, the vehicle is a beam riding device with sensors, feedback loops, and propulsion that keep it on the beam. This was successfully demonstrated on a beam-riding helicopter in 1968 (2.8). The second approach is to make the microwave beam captive to the vehicle. This approach would appear to be necessary for an airplane and for an aerostat of conventional design that must change its heading as the wind shifts direction. It is the second approach that we will want to deal with here, keeping in mind that the vehicle must have some kind of position reference to keep it approximately over the microwave beam.

In examining the interface between the vehicle and the transmitting antenna, we note that there are two aspects to controlling the beam. First, it must be focussed to as small a spot diameter as possible at the required altitude, and secondly, it must be pointed in the correct direction. If the antenna is self-focussed, as with a mechanically steerable parabolic reflector, only pointing need be considered. In that case, the simplest way to control the pointing is with a closed loop system, in which two amplitude sensors are located on the X-axis at the extremities of the rectenna, and two amplitude sensors are located on the Y-axis extremities. The sensors are balanced against each other, and any imbalance results in a telemetered signal to the transmitting antenna to change its pointing direction to produce a balance or null.

When the transmitting antenna is an active phase array (the microwave generators are distributed throughout the array), a beacon at the center of the rectenna can be used to both focus and point the beam. However, this is not a closed loop system for pointing purposes and should be supplemented with the arrangement described in the previous paragraph to make trimming adjustments to the beam so that it will be kept on the target.

The focussing of the microwave beam may be brought about by the use of the beacon in the center of the rectenna in two ways. It can be brought about with the use of the version of the retrodirective array concept (2.9) in which the phase front of the beam from the beacon is compared at the receiving point of each subarray with a clock phase which originates at the center of the array and is communicated to phase comparator locations in the subarrays (2.9). The phase difference between these two references is measured and then conjugated to provide the reference phase for the transmitted signal from each subarray. The output of the slotted waveguide radiators then tracks this reference phase. This is the approach that was used for the SPS (Solar Power Satellite) and is believed to be essential in that system because of mechanical distortion that would take place in the transmitting antenna in space.

A second arrangement that may be used if the transmitting surface does not mechanically distort or if it distorts in a predictable manner is the use of the phase front of the wave emitted by the beacon to acutate a two-axis phase comparator or interferometer arrangement at the center of the transmitting antenna. Preferably, the two interferometers, one for each axis, would be nulling devices.

As suggested by Figure 2.14, the interferometers would be mechanically rotated around the two axes by a feedback control system to produce a null in their outputs. The mechanical rotation would establish voltage outputs from precision potentiometers which would then be sent to a central processor which would send out digital signals to each subarray location, and through the use of a solid state phase shifter add or subtract appropriate phase deviations to the clock phase reference.

The accuracy with which the beam was both focussed and pointed would depend upon the accumulative tolerances in the system. Their impact upon pointing would be more serious than upon focussing. It would be expected that some form of feedback control on the pointing would be necessary. Figure 2.15 shows a monitoring arrangement on the vehicle itself which will send back to the ground by a telemetering arrangement an error signal if the beam is not centered on the rectenna. This error signal is used as an input to the microprocessor to adjust

ORIGINAL PAGE IS
OF POOR QUALITY

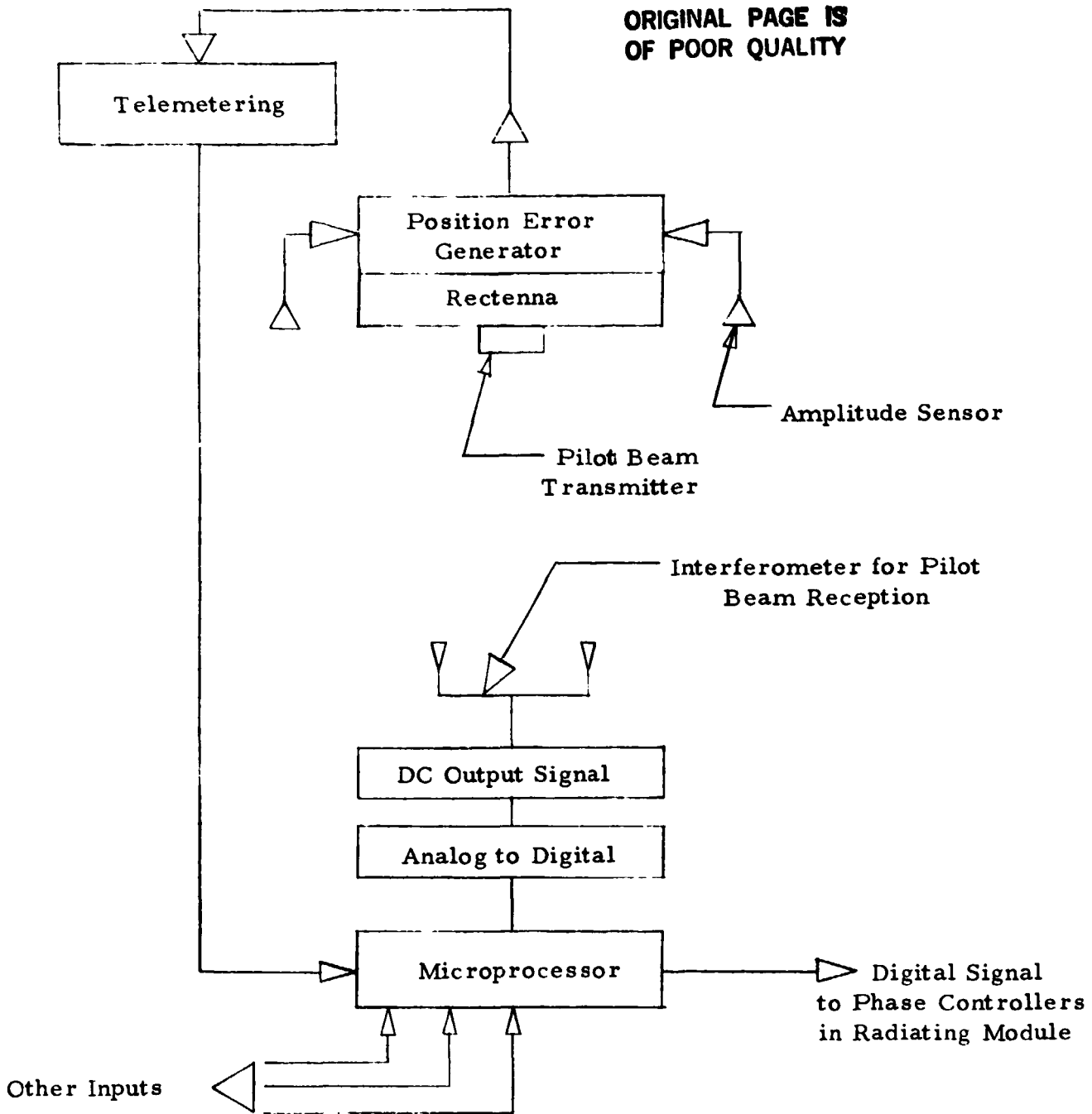

Figure 2.14 Interferometer Approach to Tracking of the HAPP Vehicle. Interferometer Tracks Vehicle by Nulling on Pilot Signal Emitted from Center of Rectenna in Open Loop Mode. Tracking Loop is closed by Amplitude Sensors at Edges of Rectenna. If Pickup is not Equal, an Error Signal is Telemetered to the GMPTS Tracking System.

the digitized phase information sent out to the phase references. This arrangement, in which a precision open loop tracking arrangement is updated by a sensitive monitoring system of the rectenna, is expected to keep the beam focussed on the center of the rectenna.

It is noted that both the arrangement just described and the one employing conjugation of the phase of the pilot beam signal require a method of assuring that the reference "clock" phase which emanates from the center of the transmitting array is precisely known at each phase comparator point. In the case of the system that uses phase conjugation, the reference or clock phase must be set precisely at some integral multiple of a wavelength (or 360°) at each of the phase comparators. In the case of the second system, the reference phase is set at each phase comparator to produce a vertical beam with a spherical wave front whose radius is approximately 20,000 meters. After this "boresighting" operation the reference phase at each phase comparator is then shifted as required to point the beam in the desired direction.

It should be noted that although the boresighting is done to focus the beam at 20,000 meters, it is possible to subsequently insert instructions into the microprocessor to adjust the focus, analogously to a "zoom lens" adjustment.

The second approach, or the one that uses the interferometers, was selected for the design of the GMPTS. Comments on this decision follow:

1. The "conjugation" approach uses a special component of considerable complexity and one which is not completely developed at this time. Yet it must be used in large numbers corresponding to the total number of radiating modules. The cost of such a system, although potentially modest in the long range, would be very high in the near term.
2. The "interferometer" approach eliminates the use of an unpredictable component without introducing other elements with the exception of the two interferometers and microprocessor at the center of the array.

3. In the "conjugation" approach backscatter from the transmitting antenna at its radiating frequency may cause interference with the beacon signal which would have to be at a frequency not far removed from 2.45 GHz, but whose power density would be many orders of magnitude lower than the density of the outgoing power beam. Adequate filtering would have to be carried out at each of the thousands of radiating modules. In the second approach, filtering is necessary at only one location at the two interferometers.

4. The "conjugation" approach eliminates the impact of mechanical distortion while the "interferometer" or preferred approach does not. However, it is believed that the structure, although rotated on tracks, will not bend nor distort sufficiently while it is being rotated to be a major factor in the proper phasing of the outgoing beam. To reach this conclusion, it is necessary to assure that the tracks will not deviate from a plane by more than $\pm 0.25''$. Precision leveling procedures that have an accuracy expressed in feet of $0.02 \sqrt{\text{distance in miles}}$ can be used in conjunction with vertically adjustable tracks to maintain this accuracy.

5. Allowance is being made in the design to permit retrofitting the system to use the conjugation system if that should become desirable at some later date, for example, to check out the components for the SPS (Solar Power Satellite).

2.5 Cost Minimization Procedures

2.5.1 Introduction

It is known a priori that the life cycle cost associated with the cost of the structure and equipment that will form the microwave beam and the cost of the 60 cycle electrical energy needed to operate the system over its assumed life-time will represent a substantial portion of the life cycle cost of the HAPP system which includes the vehicle. In this section we will present an analysis which will minimize the life cycle cost of the microwave power transmission system, where life cycle cost is defined as the sum of the initial cost of the GMPTS and the cost of prime 60 cycle energy consumed during the life of the system. The cost minimization procedure will be the principle determinant of the physical and electrical size of the GMPTS.

As background to this section, it should be pointed out that minimization of the cost of the microwave transmission system as a whole without the restrictions introduced by the vehicle would involve the size and power density of the rectenna as variables in the analysis.* However, the physical size and power density of the rectenna have been set by the demands of the HAPP vehicle which has now been reasonably well defined. This limits the cost minimization procedure to the initial cost of the GMPTS and the cost of energy consumed by it.

In this section the cost minimization procedure will first be developed. The reader who is interested in only the results should refer to Section 2.5.5 where the resulting equations are discussed.

2.5.2 Derivation of Expression for Minimum Life Cycle Cost of the GMPTS

Life cycle cost is defined as follows:

$$\text{Life Cycle Cost} = \text{Antenna Cost} + \text{Power Cost} + \text{Energy Cost (1)}$$

* See Section 2.0 of reference 2.2 for such an analysis based on initial cost only.

The antenna cost and the power cost determine the initial cost of generating the microwave beam while the third term represents the cost of the energy taken from a public utility or other source during the useful life of the system.

The terms in expression (1) can be expressed in terms of interrelated parameters as follows:

$$C = aA_t + mP_t + \frac{bcP_t}{n_1} \quad (2)$$

C = Life cycle cost.

A_t = Transmitting antenna area.

a = Antenna cost per unit area.

P_t = Total radiated microwave power.

m = Cost of equipment to convert 60 cycle power to microwave power per kilowatt of radiated microwave power.

b = Total number of hours in life cycle multiplied by duty cycle to allow for variation in output power level.

c = Cost of 60 ~ energy per kW-hr.

n_1 = Conversion efficiency from 60 ~ power to microwave radiated power.

As previously indicated, the first two terms in (1) and (2) represent the initial cost of the system. The first term represents the cost of the antenna structure while the second term represents the cost of the equipment and components to convert raw 60 cycle power into radiated microwave power.

The setting up of equation (2) assumes that the production of similar systems has reached the point where the transmitting modules which contain both antenna and power components have reached a standard cost level so that the

antenna cost is linearly proportional to its area and that the power cost is proportional to the transmitted microwave power P_t . This assumption is reflected in the proportionality constants a and m in the first and second terms of expression (2).

Now P_t in equation (2) may be expressed in terms of the peak dc power density P_d at the center of the rectenna, the wavelength λ used for transmission, the distance h between the transmitting antenna and the rectenna, and the overall rectenna efficiency n_2 by using the expression for the gain of a uniformly illuminated transmitting aperture. * P_d / n_2 is the microwave power density at the center of the receiving aperture

$$P_t = \frac{P_d h^2 \lambda^2}{A_t n_2} \quad (3)$$

This relationship is made more clear by reference to Figure 2.15. Equation (3) gives the power density at the rectenna in terms of the other parameters, at a point directly above the antenna. The received power density at the outside of the containment area, however, is reduced as shown, and this reduction and how it is accounted for in the cost equation will be discussed later.

When the value for P_t in equation (3) is substituted into equation (2), equation (4) below is obtained.

$$C = aA_t + \frac{K}{A_t} \left(m + \frac{bc}{n_1} \right), \quad K = \frac{P_d h^2 \lambda^2}{n_2} \quad (4)$$

The object is to find the transmitting antenna area A_t that gives minimum cost. To do this (4) is differentiated with respect to A_t and the resulting expression set equal to zero. If this is done A_{tm} is found to be

* Slightly better performance can be predicted from a more involved analytical procedure, but the additional complexity is not warranted by the small difference in results.

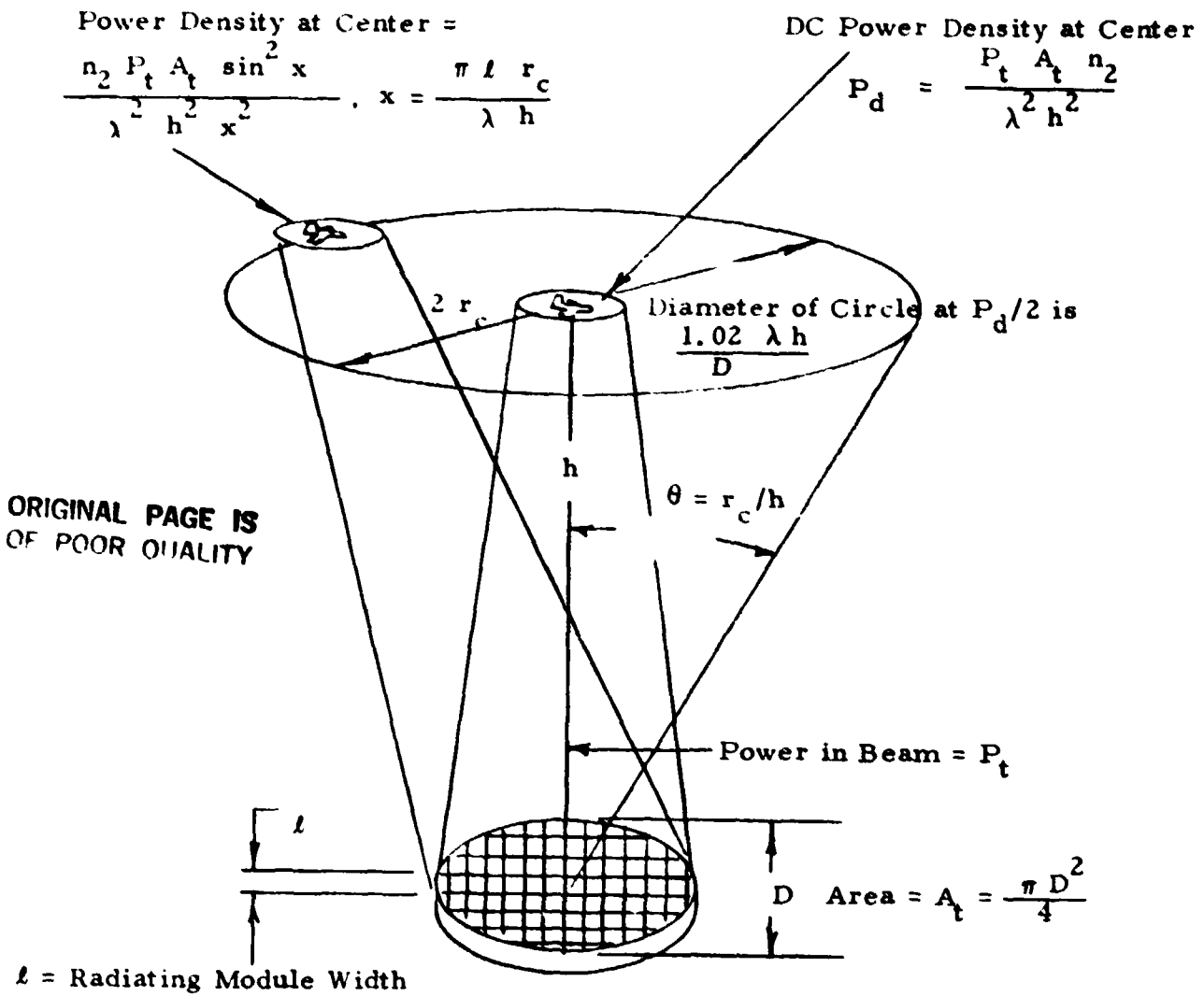

Figure 2. 15 Diagram showing the Interrelationships Between the GMPTS Parameters of Radiating Module Size, Overall Transmitting Antenna Area, and Emitted Microwave Power, and Microwave Power Density received by HAPP Vehicle as Function of Altitude and Off-Axis Location

ORIGINAL PAGE IS
OF POOR QUALITY

$$A_{tm} = \lambda h \left[\frac{P_d}{an_2} \left(m + \frac{bc}{n_1} \right) \right]^{1/2} \quad (5)$$

If (5) is substituted into equation (2), the minimum cost, C_m , is found to be

$$C_m = 2h \lambda \left[\frac{aP_d}{n_2} \left(m + \frac{bc}{n_1} \right) \right]^{1/2} \quad (6)$$

If b is set to 0, then the minimum initial cost is:

$$C_{mi} = 2h \lambda \left(\frac{am P_d}{n_2} \right)^{1/2} \quad (7)$$

Then the ratio of minimum life cycle cost C_m to minimum initial cost C_{mi} is:

$$\frac{C_m}{C_{mi}} = \left(\frac{m + \frac{bc}{n_1}}{m} \right)^{1/2} \quad (8)$$

The value of the constant "a" and therefore the "minimum cost" in the previous equations is dependent upon the area required to contain the maneuvering of an LTA or the circling of an airplane. Presumably the HAPP vehicle would still need the same requirement for power density from its rectenna at the edge of the containment area, but the power density is down from that at zenith by the factor $(\sin x/x)^2$, where x is dependent on the radiating module width as shown in Figure 2.15, so the power radiated from the transmitter and therefore P_d would have to be increased by the factor $(x/\sin x)^2$. The required increase in power may be reduced by decreasing the size of the radiating module. However, this introduces an additional cost because the cost of the phase control electronics for the radiating module remains fixed regardless of the size of the module, at least over the

range of sizes that are of interest.

The impact of the physical size of the module may be taken into account by breaking the factor a , the unit area cost of the antenna, into two principle components, designated a_1 and a_2 . a_1 is the cost associated with the material and fabrication cost of the slotted waveguide sections. It tends to remain constant and therefore the total cost of the slotted waveguide sections may be obtained by multiplying a_1 by A_t . a_2 is associated with the costs of the phase control electronics, associated mechanical components, and their interfacing with the rest of the antenna system. Its cost for each radiating module tends to be the same regardless of the size of the radiating module so that the total cost in the transmitting array is equal to $k_1 A_t / \ell^2$ where k_1 is the cost of the components for each radiating module and ℓ is the side dimension of the radiating module; that is $a_2 = k_1 / \ell^2$.

The equations (6) and (7), modified for flight radius r_c , then become

$$C_{m, r_c} = 2h\lambda \left[(a_1 + a_2) \left(\frac{P_d}{n_2} \right) \left(\frac{x}{\sin x} \right)^2 \left(m + \frac{bc}{n_1} \right) \right]^{1/2} \quad (9)$$

$$C_{mi, r_c} = 2h\lambda \left[(a_1 + a_2) \left(\frac{P_d}{n_2} \right) \left(\frac{x}{\sin x} \right)^2 m \right]^{1/2} \quad (10)$$

The ratio of C_{m, r_c} to C_{mi, r_c} remains the same as in equation (8).

**ORIGINAL PAGE IS
OF POOR QUALITY**

In equations (9) and (10) the correcting terms involving the size of the radiating module increase the cost of the transmitter and this increasing cost becomes most significant if the angular deviation of the beam from zenith becomes more than about 3°. However, the increase in cost may be minimized for each value of angular deviation by a suitable choice of the size of the radiating module.

The combined additional cost of the phase control electronics and the additional radiated power required to bring the rectenna power up to full level when the aircraft is at the edge of the containment area is represented by the multiplication factor

$$M = \frac{x}{\sin x} \sqrt{\frac{a_1 + \frac{k_1}{l^2}}{a_1}} \quad (11)$$

This important factor M can be minimized by a tradeoff between the cost of additional radiated power output and the cost of additional electronics for more radiating modules once the containment area of the HAPP vehicle is specified. The minimization of M will be discussed in some detail in Section 2.5.5.

2.5.3 Microwave Power Density at the Transmitting Antenna Face for
Minimum Life Cycle Cost and as Given Uniquely by the Ratio
of the Cost Parameters a and m + bc/n₁

If the expression \bar{P}_t for the radiated power from the transmitting antenna (equation 3) is divided by the transmitting antenna area A_{tm} for minimum cost, then we obtain the microwave power density at the transmitting antenna face which is of general interest. Moreover, it is found that the power density for minimum cost is equal to the ratio of the cost parameter a to the sum of the power cost parameter m and the energy used during the life cycle. The expression follows:

$$\begin{array}{l} \text{Power density at the transmitting antenna} \\ \text{face for minimum life cycle cost} \end{array} = \frac{a}{m + bc/n_1} \quad (12)$$

This is a rather remarkable result and follows from the fact that the expression for power density is the same as equation (3) except that A_t in the denominator is changed to A_t^2 . When equation (5) is inserted into equation (3), the substitution results in cancelling out all of the terms except those in equation (12). So the power density for minimum cost of the transmitter is independent of wavelength, distance between the transmitter and rectenna, and the dc power density output and efficiency of the rectenna.

2.5.4 Limitations on Applications of Analysis in 2.5.2

The analysis of cost in 2.5.2 is made possible by the use of the gain expression for an antenna from which the ratio of peak power density P_d at the center of the antenna pattern to the total power radiated from an aperture area A_t may be found. For many applications, the receiving area is sufficiently small so that the average power density over the receiving area approximates closely the peak power density at the center. Even though the rectenna area for the lighter-than-air vehicle is large, the equations derived in Section 2.5.2 still give approximately correct results. This is particularly true if the shape of the transmitting antenna on the ground approximates the shape of the rectenna, as is the case of the design of the GMPTS for the lighter-than-air high altitude vehicle.

2.5.5 Using the Expressions of Cost for Sensitivity Analysis

The cost equations bring together all of the important design parameters into simple formulae that reveal by inspection how the parameters affect the cost. Some of the relationships are nonintuitive. For example, the minimum cost varies linearly with the separation distance h and the wavelength λ and not as the square as is suggested by an intuitive application of the inverse square law.

The cost varies as the one half power of the "a", "m", and "bc" cost parameters and thus the cost is not as sensitive to these parameters as might be intuitively thought.

There are some relationships, however, that deserve further discussion. An examination of equation (6) for minimum life cycle cost indicates the importance of the energy term bc/n_1 . m is typically \$200 while bc/n_1 would amount typically to \$730 in only one year if the facility were operated at full duty cycle. Hence, under the assumption of full duty cycle use, the cost is much more sensitive to the energy that the GMPTS requires than to the construction of the power portion of the facility.

However, as suggested by Figure 2.3, the duty cycle for the LTA is very low if it is not necessary for the vehicle to cruise to maintain altitude. But, because the complete system including the LTA and the GMPTS is designed to operate most efficiently when the rectenna is producing 200 kilowatts of power, it is found that both the rectenna and the GMPTS will work at comparatively poor efficiency when the microwave power transmission system is required to operate with five kilowatts of power output from the rectenna. Consequently, the effective duty cycle will be considerably higher than that derived directly from Figure 2.3.

It is obvious, however, that the microwave-power-transmission-system life cycle cost for an LTA system, which requires power only to counteract the drag effects of the wind, will be considerably less than for an airplane or a helicopter system.

Another area that needs further discussion is the cost related to the containment area required by the air vehicle for maneuvering, because the costs are very sensitive to this containment area. The increased cost factor is given by equation (11). In Figure 2.16, M in equation (11) is plotted as a function of l , the side dimension of the radiating module, for three different values of off-zenith angle, 0.1, 0.05, 0.025 radians (5.72, 2.86, and 1.43 degrees). Assumptions for cost of a_1 and k are \$100 each. k includes the cost of the phase control electronics for each module and the cost of integrating them into the phase control system. Figure 2.16 indicates that the minimum cost of a system that allows for an off-axis angle of 5.72 degrees is twice that of a system that needs only 1.43 degrees of off-zenith operation.

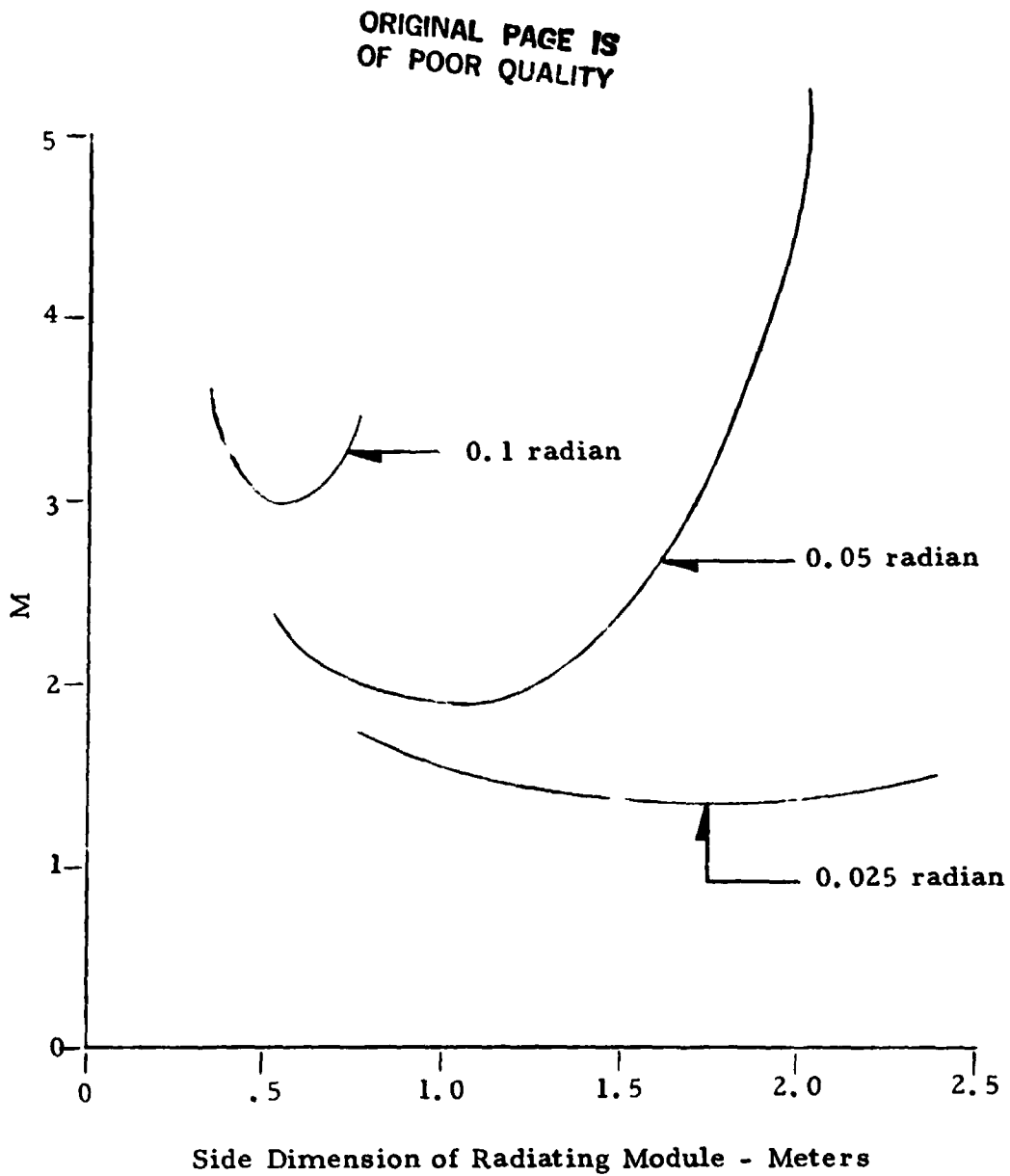

Figure 2.16 Value of the Cost Multiplier Factor M (Equation (11)) as a Function of the Side Dimension of the Radiating Module and the Off-Axis Location of the HAPP Vehicle. Off-Axis Angle is expressed in Terms of Radians. 0.05 Radian is 2.87 Degrees and Corresponds to an Off-Axis Location of 1 Kilometer at an Altitude of 20 Kilometers. A Value of \$100 was used for Both a_1 and a_2 in Equation (11).

Table 2.1 has been prepared to show the cost sensitivity to substantial variations in the various factors that go into the cost equations. The life cycle cost of the system is remarkably insensitive to substantial errors in estimating any one factor. For the LTA HAPP system, the range of the life cycle cost is about two to one.

Table 2.1 also shows a number of other interesting costs and technical characteristics, including antenna, power, and energy costs, antenna area, maximum radiated power, aperture to aperture efficiency, maximum radiated power density, and maximum radiated power per magnetron. This latter characteristic is of particular importance and indeed is found to be a principal determinant of the final dimensions or scale of the reference system, as described in Section 3.0.

Parameter Varied	Factor	P_d kW/m ²	n_2 %	a_1 \$/m ²	k_1 \$	f m	a_2 \$/m ²	θ Radians	*** m	bc/n ₁ \$/kW	Min. Life Cycle Cost in \$1000's	Max. Radiated Power at $\theta = 0$ kW	Antenna Area in m ²	Antenna Cost in \$1000's	Power Cost in \$1000's	Energy Cost in \$1000's	Aperture to Aperture Effic. at $\theta = 0$	Max. Radiated Power Density kW/m ²	Max. Radiated Power Per Magnetron kW
None		0.4	80	100	100	0.75	178	.0375	200	200	1,262	1577	2268	630	316	316	18.8%	0.695	1.56
bc/n ₁	x 2	0.4	80	100	100	0.75	178	.0375	200	400	1,545	1287	2788	772	257	515	23.1%	0.46	1.04
k ₁	x 2	0.4	80	100	200	0.75	356	.0375	200	200	1,615	2020	1770	887	403	403	17.5%	1.14	2.56
bc/n ₁	x 25	0.4	80	100	100	0.75	178	.0375	200	5000	4,504	441	8101	2,252	86.5	2,165	NA	0.054	0.122
P _d	x 0.5	0.2	80	100	100	0.75	178	.0375	200	200	895	1110	1610	447	222	222	13.4%	0.689	1.55
f	x 1.33	0.4	80	100	100	1.00	100	.0375	200	200	1,148	1434	2870	574	287	287	24%	0.499	1.99
θ	x 2.00	0.4	80	100	100	0.75	178	.0750	200	200	1,675	2097	3010	837	419	419	25%	.696	1.56
f	x 1.33	0.4	80	100	100	1.00	100	.0375	200	5000	4,139	398	290	10347	93	1,700	NA	.038	0.153
bc/n ₁	x 25	0.4	80	100	200	1.00	200	.0375	200	5000	5,069	487	355	8449	2,535		NA	.057	0.231
bc/n ₁	x 25	0.4	80	100	200	1.00	200	.0375	200	5000	5,069	487	355	8449	2,535		NA	.057	0.231
P _d	x 1.33	0.4	80	100	200	1.00	200	.0375	200	5000	5,069	487	355	8449	2,535		NA	.057	0.231

ORIGINAL PAGE IS OF POOR QUALITY

Table 2.1 Sensitivity Analysis of Minimum 10-Yr Life Cycle Cost *

* Assumptions Development Costs are assumed to be Written Off and Some Production Experience Accumulated

** Reference System

*** m is cost of power per unit - elsewhere in table m is symbol for "meter"

2.6 Conversion of 60-Cycle Power Into Filtered DC Power

The conversion of 60-cycle power into filtered dc power is a straightforward technology. It simply involves a three-phase full-wave rectifier and the necessary filtering components to reduce the ripple to the needed level. However, if the dc power must be supplied within a narrow voltage range, it would ordinarily be necessary, because of the variability in the supply 60-cycle voltage, to use the equivalent of a 60-cycle transformer with a varying turns ratio or to introduce a varying resistance in series with the dc load. It is presumed that the buck-boost coil located in the magnetron package and controlled by the error signal resulting from a comparison of the actual output with an output reference would eliminate the need for such procedures.

Normally, the cost of the inductance and capacitance to achieve a well filtered dc output would be considerable. Again, the buck-boost coil promises to eliminate a considerable amount of filter inductance and capacitance by varying the magnetic field at a sufficiently rapid rate to keep the power output constant. However, this will introduce a small amount of internal phase change in the magnetron directional amplifier with which the relative slow response of the corrective circuitry cannot cope. The question that is raised is how much phase modulation can be tolerated in a non-communication system where the phase ripple would have the effect of only a minor distortion of the beam.

2.7 RFI-EMI Considerations

Radio frequency interference, or in a larger sense electromagnetic interference, from the GMPTS is solely associated with the microwave generators.

The low noise level found in the common microwave oven magnetron was an important discovery encountered in the assessment of the magnetron directional amplifier for the SPS. It was found that the ordinary microwave oven magnetron selected at random and run from a well-filtered dc power supply and with the external source of filament power removed after it was used to start the tube operation characteristically had a spectral noise density (noise in 1-Hz bandwidth) that was 160 dB below the carrier at all frequencies removed from the carrier by more than 20 MHz (other than the harmonic frequencies) (2.4, 2.6).

This was also found to be the case when the magnetron was combined with a ferrite circulator and operated as a directional amplifier. The noise level found is so low that the GMPTS should not be a source of interference to uses of the frequency spectrum outside of the ISM (Industrial Scientific Band) band that extends from 2.4 to 2.5 GHz. The ISM band is reserved for such non communications-applications of the spectrum as the microwave oven, medical diathermy, and scientific investigations, etc.

It was also found that, based upon measurements of harmonic output from the magnetron directional amplifier (2.6, 2.10) and upon further attenuation of the harmonic radiation by the slotted waveguide array (2.10) that the radiated harmonic energy would probably be so low that it would not be a source of interference. Direct measurement of harmonic output from the magnetron indicated that these were 70 dB to 90 dB down from the carrier. From the measurements in reference 2.10 there appeared to be a further reduction of the harmonic level by 30 dB.

In the event that there should still be some residual harmonic interference, it is possible to put additional filtering into the output of the magnetron and reduce the level further by 30 to 40 dB, as was done experimentally in Section 8.0 of reference 2.4.

Although low noise very close to the carrier is not considered essential for this application, measurements of this noise were found to be low. For example, the noise in a 1 kHz band 10 kHz removed from the carrier is 110 dB below the carrier level. (2.6)

2.8 Thermal Design

The thermal design of the GMPTS is relatively straightforward and simple. All the components that may need cooling, such as the magnetron directional amplifiers and possibly the input 60-cycle transformers, are air-cooled. Each magnetron has its own cooling fins as an integral part of the package. A small blower fan is used to cool each individual magnetron. If for some reason the fan becomes inoperative and the magnetron overheats, the temperature rise is sensed and the buck-boost coil is given an input which provides a high magnetic field which reduces the anode current flow in the magnetron to near zero. This eliminates the backheating of the filament so that the filament cools off in a few seconds. Then when the magnetic field in the buck-boost coil is restored to its normal value, the cold filament prevents the tube from starting until programmed to do so.

The expansion and contraction of the entire array with temperature is a factor that must be taken into consideration in focussing the microwave beam, but the correction for this can be easily made, as discussed in Section 3.2.5.

2.9 Mechanical Design

The details of the mechanical design of the GMPTS are addressed to varying degrees depending upon the area of interest. The designs of the radiating module and the subarray are dealt with in considerable detail, while the design of the supporting structure for the subarrays is minimally discussed.

The principal thrust in this study has been the conceptual design of the microwave portion of the GMPTS. The major interface of this design with the mechanical design of the GMPTS is through an estimate of the weight of the microwave subarrays, and with imposing tolerances on the flatness of the bed upon which the antenna rotates.

No attention has been given to the subject of a radome or other environmental protection which the GMPTS may need in many geographical locations.

REFERENCES FOR SECTION 2.0

- 2.1 "Microwave Power Transmission System Studies, " Volume II, Pages 3-8
NASA CR-134886 - Raytheon Co., Dec 1975. NASA Contract NAS3-17835.
- 2.2 W. C. Brown, "Design Definition of a Microwave Power Reception and
Conversion System For Use on a High Altitude Powered Platform, " NASA-
CR-156866.
- 2.3 W. C. Brown and J. F. Triner, "Experimental Thin-Film, Etched-Circuit
Rectenna, " Paper k-4, 1982 IEEE MTT-S International Microwave Sym-
posium Digest, Dallas, Texas, June 14-17, 1982, Associated Contract is
NASA LeRC NAS3-22764.
- 2.4 W. C. Brown, "Satellite Power System (SPS) Magnetron Tube Assessment
Study, " NASA Contractor Report 3383, Feb, 1981, NAS8-33157.
- 2.5 Same as 2.1 except page reference is 6-17.
- 2.6 W. C. Brown, "Microwave Beamed Power Technology Improvement, "
Final Report JPL Contract Number 955104, Raytheon PT-5613, May, 1980.
- 2.7 E. E. David, "Phasing by R. F. Signals, " In Okress "Crossed Field Micro-
wave Devices, " Academic Press 1961, Vol II, pp. 375-399.
- 2.8 W. C. Brown, "Experiments Involving a Microwave Beam to Power and
Position a Helicopter, " IEEE Trans. on Aerospace and Electronic Systems,
Sept, 1969, pp. 692-702.
- 2.9 IEEE Trans. Antennas and Propagation (Special Issue on Active and Adap-
tive Antennas) Vol. AP-12, pp. 140-246, March, 1964.
- 2.10 R. M. Dickinson, "Beamed Microwave Power Transmitting and Receiving
Subsystems Radiation Characteristics, " JPL Publication 80-11, June 15,
1980.

3.0 DESIGN OF THE GROUND-BASED MICROWAVE POWER TRANSMISSION SYSTEM - GMPTS

3.1 Introduction

Based upon the discussions in Section 2.0 that includes some discussion of decisions that were made prior to the study covered by this report, it has been concluded that the GMPTS design will be an active phased array that will be electronically steerable to focus the microwave beam upon the rectenna in the HAPP (High Altitude Powered Platform). It will also be mechanically rotatable on a flat horizontal plane on the earth's surface to keep the linearly polarized rectenna aligned with the linearly polarized transmitting antenna.

To help understand the basic design concept of the GMPTS, it is helpful to visualize its physical construction or appearance as being of a modularized nature, consisting of a hierarchy of two modules. The smallest module is the radiating module which consists of a section of slotted waveguide radiator, 0.56 square meter in area, and its phase control circuits. Four of these radiating modules ("RM's") are gathered together into a subarray which adds the functions of microwave power generation, power amplitude control, and microwave power distribution to the radiating modules. 1352 of these subarrays, ("SA's") are assembled to compose the 39 x 78 meter GMPTS, which adds the functions of beam steering, microwave excitation circuitry, and the source of the dc power. The overall composition of the GMPTS is shown in Figure 3.1. Table 3.1 gives additional data on the transmitter design.

It should be understood that the specific areas of the individual radiating module and of the entire transmitting antenna are not necessarily those that would be arrived at if it were determined to go ahead with a system. For example, if the system were built in Florida, it would not be necessary for the system to withstand 95 knot winds and so the system would be considerably smaller. And because it is not now known with a high degree of certainty how much room will be required for maneuvering or circling flight of the LTA HAPP, the costs would be different than those obtained by assuming a maximum off-zenith excursion of 0.75 kilometer. And if the GMPTS were to be used for a system in which the

ORIGINAL PAGE IS
OF POOR QUALITY

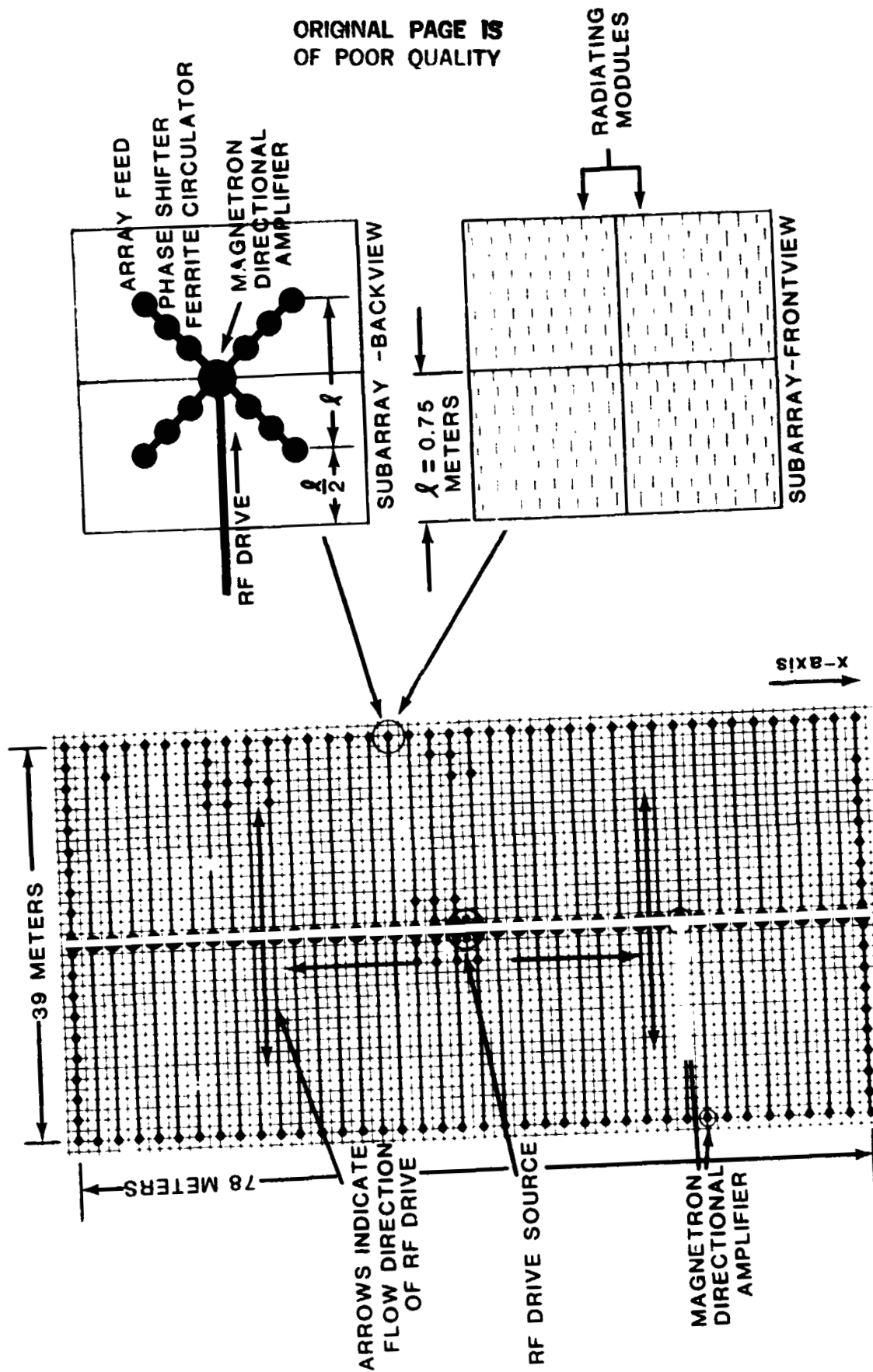

Figure 3.1 Reference Design of the Ground-Based Microwave Power Transmission System (GMPTS) for the LTA-HAPP Vehicle Showing the Modularized Construction and the Microwave Drive Chain. The GMPTS Consists of 1352 Subarrays Each of Which Consists of a Magnetron Directional Amplifier with Its Associated Components and Four Slotted Waveguide Radiating Modules Whose Phase and Amplitude are Controlled.

Table 3.1

DATA ON GMPTS

Total area of the transmitting antenna	3042 meters ²
Dimensions of the transmitting antenna	39 x 78 meters
Wavelength of radiation	0.1226 meter
Microwave power density on rectenna at distance of 20 kilometers	500 watts/meter ²
Radiated microwave power when pointed at zenith	988 kilowatts
Radiated power when pointed at edge of confinement area	1176 kilowatts
Maximum 60 cycle power taken from utility	1960 kilowatts
Number of subarrays in antenna	1352
Number of radiating modules	5408
Normal range of scan angle	\pm 4 degrees in all directions
Microwave power source	Microwave oven magnetron operated as directional amplifier
Method for tracking translational position of vehicle	Microwave interferometer aided by amplitude sensors on vehicle
Beam pointing control	Digital phase-shifting matrix that controls phase at radiating module level
Method for tracking angular position of vehicle	Yaw sensors on vehicle controlling mechanical rotation of GMPTS

vehicle was an airplane, a larger transmitting antenna to increase the transfer efficiency of energy would be desirable.

Additional understanding of the broader aspects of the GMPTS may be obtained by examining its interaction with the LTA-HAPP vehicle. This is done with the aid of Figure 3.2. As Figure 3.2 indicates, there is considerable flow of information between the LTA HAPP vehicle and the GMPTS.

The GMPTS is concisely defined in Figure 3.2 as a means of (1) generating a microwave beam of varying power level, (2) pointing and focussing the beam on the rectenna and (3) maintaining alignment of the polarization of the microwave beam with that of the LTA-HAPP. The GMPTS is essentially slaved to the position and angular attitude of the LTA and to its power requirements.

Data send from the yaw sensor in the LTA and telemetered to the GMPTS controls the mechanical rotation of the GMPTS.

In cooperation with a pilot microwave beam mounted at the center of the rectenna in the LTA, microwave interferometers in the GMPTS track the position of the LTA and provide data for pointing the microwave beam at the LTA. The output data from the interferometer can also be used to define the coordinate position of the LTA and these coordinates are telemetered to the navigation system internal to the LTA.

Because the control of the microwave beam pointing by the interferometers is not a closed loop system, amplitude sensors are added to the front, back, and two sides of the rectenna and their outputs interconnected to produce error signals if the microwave beam is not centered on the rectenna. These error signals are telemetered to the ground and used as a vernier adjustment of the beam pointing.

The microwave power output from the GMPTS is controlled by a telemetered signal from the navigation control center on the LTA. The navigation control system reacts to any position change of the vehicles, as relayed to it from the

ORIGINAL PAGE IS
OF POOR QUALITY

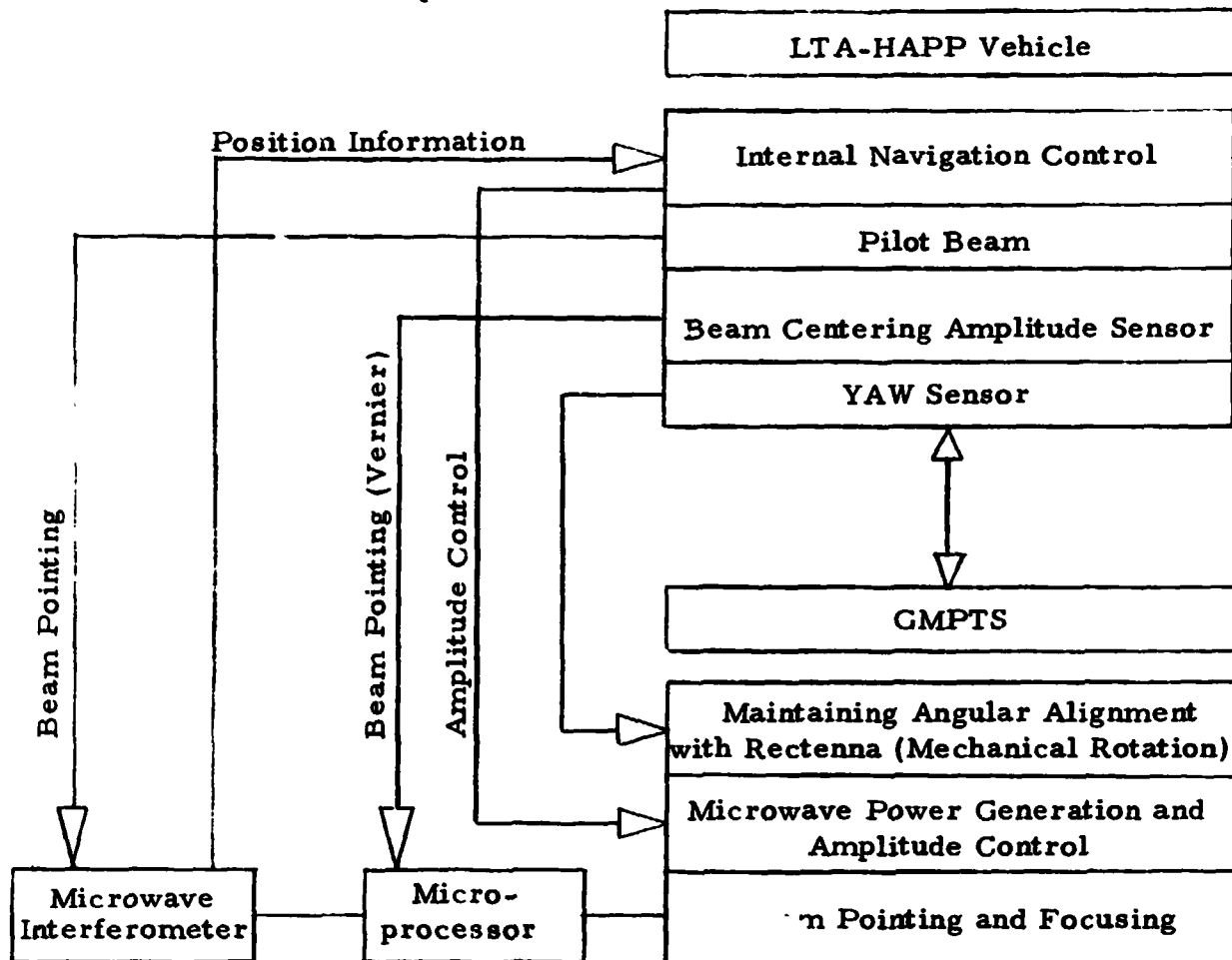

Figure 3.2 Diagram Indicating the Flow of Information Between the GMPTS and the LTA-HAPP Vehicle and How This Information is Used to Control the Pointing of the Beam, to Maintain Polarization Alignment of the GMPTS and the Rectenna, and to Control the Level of Microwave Power Density Upon the Rectenna.

microwave interferometers on the GMPTS, by calling for a change in microwave power radiation.

The design of the interferometer tracking system calls for a two-axes gimbal mount of the interferometers so that the plane established by the ends of the four horns is parallel to the plane of the phase front of the pilot beam. The gimbal mount itself is rigidly attached to the rotating GMPTS structure so that the interferometer X and Y axes remain aligned with the X and Y axes of the GMPTS as it rotates. This arrangement results in the microwave beam always being pointed at the rectenna although the longitudinal axis of the rectenna and the latitudinal axis of the GMPTS may not be precisely aligned as the result of a delay in the rotational tracking response of the GMPTS to a change in LTA heading. However, a misalignment will result in readings of position coordinates that will need to be corrected before telemetering to the guidance system in the LTA.

When the axes of the GMPTS and the rectenna are aligned, the interferometer gives readings of the coordinates of a vector drawn from the zenith to the position of the pilot beam transmitter with respect to the longitudinal and latitudinal axes of the rectenna. The relationship to points of the compass has been lost. However, it is possible to relate the rotation of the GMPTS to the earth's fixed coordinate system, and thus process the data to that coordinate system before relaying to the LTA-HAPP.

Although this brief discussion may be helpful in visualizing the physical composition of the GMPTS and its interface with the LTA-HAPP vehicle, an understanding of how the conceptual design meets the set of requirements imposed upon it must be based upon a consideration of various subsystem functions. These subsystems may be grouped as (1) microwave beam pointing and focussing, and maintenance of polarization alignment, (2) microwave power generation, distribution and control of its amplitude, and (3) conversion of 60-cycle power into dc power. The discussion in this section of the report, therefore, will follow that breakdown.

A description and discussion of the design that follows will become rapidly more complex as the details of the major subsystems and their interactions with each other are examined. The electrical complexity is caused in large measure because the transmitting antenna is an active phased array and each radiating module must be given instructions with respect to the phase and amplitude of its output power which it must then obey. However, this array with its function of transmitting power, is much less complex and costly than the conventional phased array used for radar purposes, chiefly because the output phase of each radiating element (dipole or slot) does not have to be individually controlled. In the GMPTS design, 64 such radiating elements are combined into one radiating module. On the other hand, the power transmission array handles much more average power, putting a premium upon disassociating the information and power functions of the system from each other as much as possible.

The discussion will start with the subject of microwave beam pointing and focussing.

3.2 Design for Microwave Beam Pointing, Focussing, and Retaining Polarization Alignment with Rectenna Rotation

The microwave beam in the GMPTS has three requirements imposed upon it:

- (1) It must be focussed to as small a diameter as possible at the rectenna location.
- (2) It must be able to follow changes in the rotational attitude of the vehicle.
- (3) It must be able to follow changes in the translational position of the vehicle.

The focussing of the antenna is achieved through boresighting it at zenith and providing it with a spherical phase front centered upon the rectenna at 20 kilometers. Subsequently, it is possible to change the focal point to give the array a "zoom lens" capability by digital programming.

The ability of the GMPTS to track the LTA-HAPP in angular rotation is achieved by the mechanical rotation of the transmitting antenna in response to telemetered information from the HAPP vehicle as it changes its angular position.

The translational position of the air vehicle as measured from the X and Y axes of the GMPTS is achieved by using two interferometers which sense the angular position of the vehicle with respect to the X and Y axes of the GMPTS. The angular position readout is converted into digital information that changes the reference phase in each of the 5408 radiation modules.

From the viewpoint of complexity, keeping the microwave beam pointed at the rectenna on the HAPP vehicle is the most difficult requirement. Before starting the discussion of this subject it may be helpful to refer to Section 2.4.3 which will provide additional insight into the advantages and disadvantages of the "interferometer" approach and why it was chosen as the preferred approach.

3.2.1 Interface of the Phase Control Matrix with the Radiating Module

As shown in Figure 3.3, the phasing control at the module level consists of two inputs. One is the reference clock phase derived from the clock phase distribution matrix. The second phase input is that derived from the change in position of the HAPP vehicle and the tracking of that change by the interferometer. The second phase input, also derived from a distribution matrix, is added to the clock phase reference through a digital phase shifter. This function is performed at a low power level so that there is no need to develop phase shifters that operate at high power level for this application. A five bit phase shifter---one that has a resolution of 11.5° ---is proposed.

The resulting phase shift is used as an input to the phase comparator which compares the reference phase with the phase of the output of the radiating module. If there is a difference, the difference will activate a mechanical phase shifter on the output side of the microwave generator, through suitable control circuitry^{2,3}, to reduce the difference to near zero.

ORIGINAL PAGE IS
OF POOR QUALITY

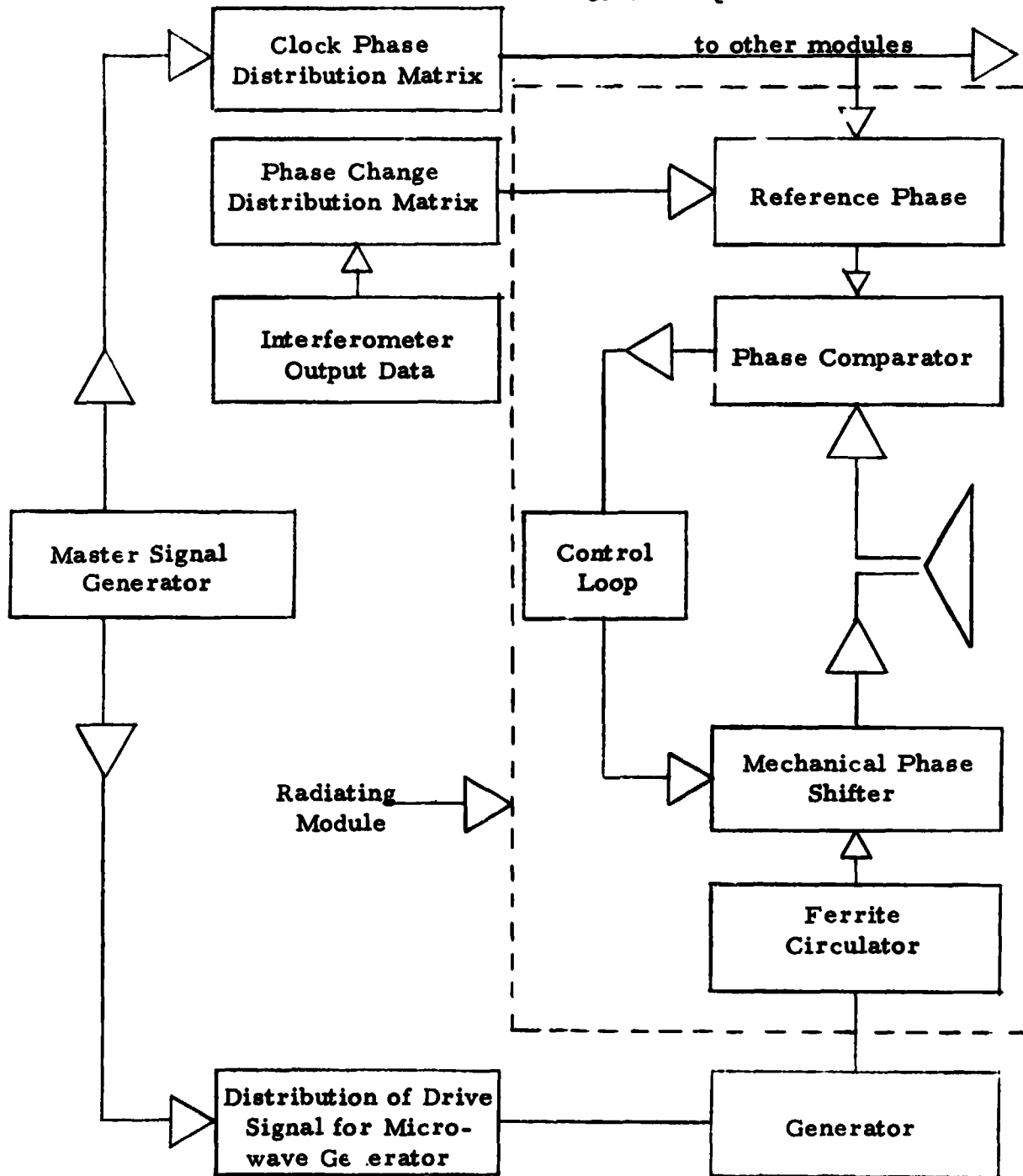

Figure 3.3 Interface of the Phase Control Matrix with the Radiating Module

A mechanical phase shifter can be used in this application because the phase changes demanded from the system are very slow. The advantage of the mechanical phase shifter is that it can operate at high power levels and within the waveguide structure (as indicated in Figure 3.9).

In the proposed design, the reference phase is independent of the phase of the output of the microwave generator (before the phase shifter), except that the clock phase and the rf drive for the microwave power generation system must stem from the same master 2.45 GHz signal generator as shown in Figure 3.3. This independence is made possible by providing the mechanical phase shifter with a $\pm 180^\circ$ phase shifting capability to cover all situations.

3.2.2 Phasing Information Generation and Distribution

This system consists essentially of three parts: (1) the determination of the amount of phase control by the interferometric tracking of the pilot signal, (2) the digitizing and distribution of the phase information to the phase reference sites in each radiation module, and (3) the distribution of the clock phase reference to each site and the boresighting of the array. These will be discussed in that order.

3.2.2.1 The Determination of the Amount of Phase Control by the Interferometric Tracking of the Pilot Signal: Pilot Signal Transmitter

As explained in Sections 2.4.3 and 3.1, and in Figures 2.14 and 3.2, the position of the HAPP vehicle is tracked by two microwave interferometers in combination with a pilot transmitter located at the center of the rectenna. The two interferometers, one indicating rotation around the X axis of the GMPTS and the other around the Y axis of the GMPTS, are mounted on a common gimbal mount so that the plane of the mouths of the four horns is parallel to the phase front of the signal coming from the pilot beam transmitter.

The operating principle of a microwave interferometer can perhaps be best presented by a description of the device itself. As shown in Figure 3.4, there are two horn collectors at the ends of two waveguide arms attached to two ports of a "Magic T". The arms differ in length by one quarter of a wavelength as measured in the waveguide. Under these circumstances, when the two horns are aligned with the phase front of the beam radiated by the pilot transmitter in the HAPP vehicle, equal amounts of power are collected in the E and H arms of the "Magic T". These powers can be converted to potentials which can be subtracted from each other to produce a null in the signal output. This null must take place when the pilot signal is effectively located on a vertical line running through the center of the transmitting antenna. More about boresighting procedures will be discussed later.

Now, when the position of the pilot beam changes, the phase front of the beam will arrive at one of the horns before the other and the power in the E and H arms will change, decreasing in one and increasing in the other, and giving an error signal with either a negative or positive polarity, depending upon the direction of the position change of the HAPP vehicle and its associated pilot beam. The error signal will be used in a control loop to rotate the interferometer around its axis to again produce a null (or near null). The mechanical rotation will be used to produce an analog voltage which then becomes the basis of changing the phase of the outputs of the radiating modules, as discussed in Section 3.2.2.2.

The sensitivity or the ability of the interferometer to resolve the angular displacement of the plane of the horn ends from the plane of the incoming wave is very great. However, its accuracy will depend upon how well it is calibrated or boresighted. The boresighting can be done on an antenna range, but it is essential to recognize that the boresighting on the antenna range must be translated into a boresighting at vertical zenith when the interferometer is positioned on its mount on the GMPTS.

ORIGINAL PAGE IS
OF POOR QUALITY

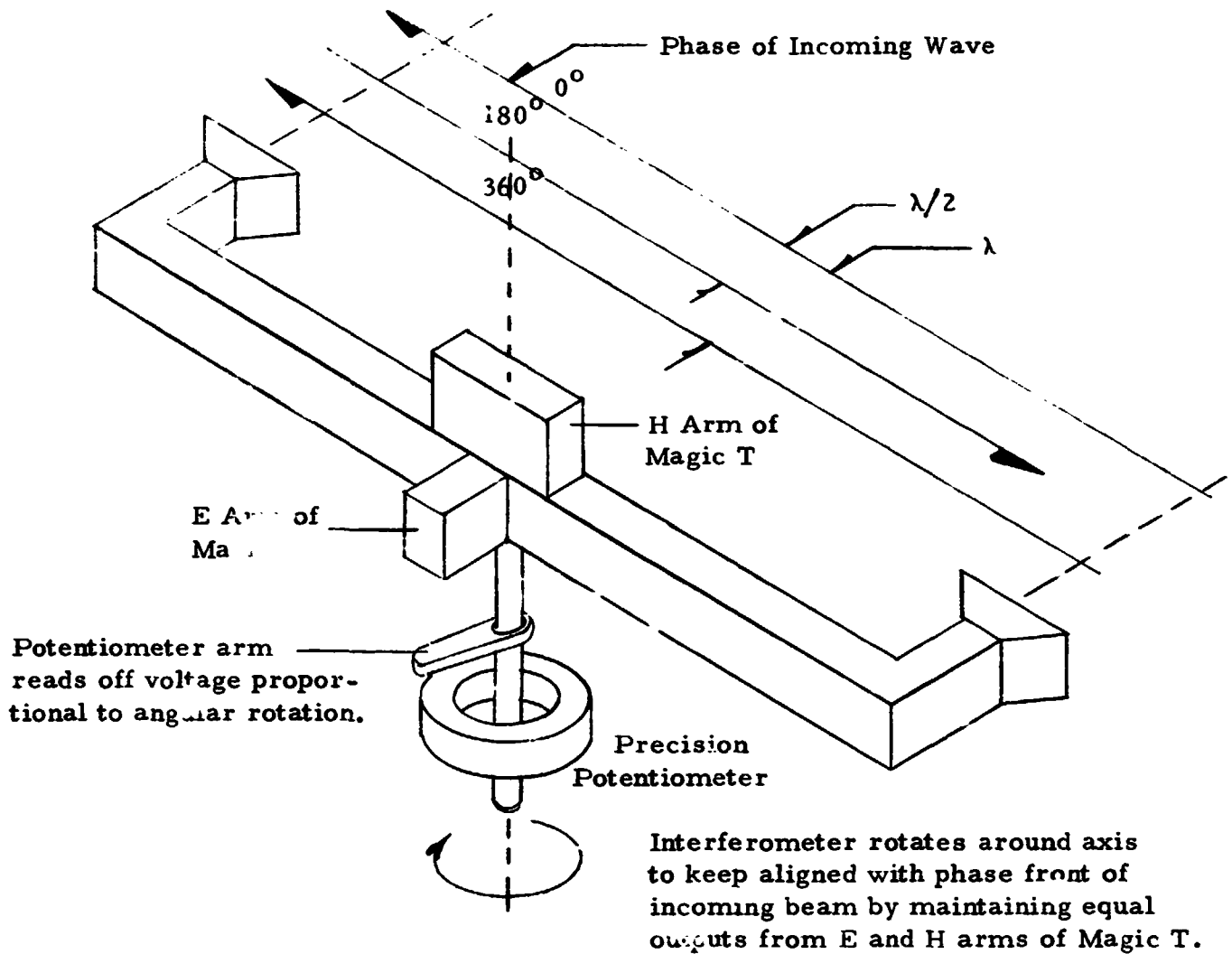

Figure 3.4 Principle of Operation of the Microwave Interferometer Used to Track the Position of the LTA-HAPP Vehicle. Two Interferometers are used, One Tracking the LTA Around the Y-Axis of the GMPTS and the Other Around the X-Axis of the GMPTS.

The degree of sensitivity achievable depends upon the noise level of the receiver and the power level of the arriving signal. Calculations that have been made indicated that, for a resolution of one meter at 20,000 meters, a signal output of about eight watts in the pilot transmitter is adequate. Calculations were based upon the theoretical noise level of a receiver with a bandwidth of 100 kHz, much wider than actually necessary for the highly stabilized frequency of the transmitted signal generator. For this computation, an effective aperture of $4\lambda^2$ for each of the horns, and a distance between the horns of one meter were assumed. The transmitter was assumed to have an aperture area of 0.25 meter^2 which would place its half power points at ± 6 degrees, and provide it with a gain of approximately 300. If there is extensive rolling or pitching of the HAPP vehicle, it may be desirable to mount the pilot transmitter on a gimbal and have it point directly towards the GMPTS at all times, using the phase front of the 2.45 GHz power beam as a phase front reference. ^(2.8) Under these circumstances, the aperture area of the transmitting antenna could be substantially increased with a resulting substantial reduction in the amount of radiated power.

In Section 2.4.3 it was explained that one of the distinct advantages of the interferometric approach over that of the retrodirective array system employing conjugation at each of the 5408 radiation modules was the ability to attenuate out any 2.45 MHz signal arriving at the horn faces by using the waveguide itself in the interferometer as a cutoff filter. By selecting a pilot beam frequency of 3500 MHz, that is within the range of frequencies allocated for radiolocation applications, and then selecting a waveguide whose cutoff frequency is 3200 MHz, it is calculated from readily available expressions that the attenuation of a 2.45 GHz signal would be 374 dB per meter or 187 dB in each half-meter arm of the interferometer. In addition, it is computed that the directivity of the horn as well as the directivity of the outgoing beam would limit the pickup of the outgoing 2.45 MHz signal to about one milliwatt in each of the horns. On the other hand, of the eight watts of power at 3500 MHz radiated by the pilot transmitter, only about 2×10^{-8} milliwatts will be collected by each of the interferometer horns. But nearly all of this will reach the "Magic T" while the 2.45 MHz one milliwatt signal will be attenuated to 2×10^{-19} milliwatts. The ratio of the two signals then is over 100 dB.

From the foregoing discussion and specific design scenario, it is evident that the interferometer arrangement and the associated pilot beam are relatively straightforward. A detailed design of the interferometer and pilot beam, however, would have to take many different parameters into account to optimize the design. Some of these parameters would be frequency and power level of the source of microwave power for the pilot beam, the area of the pilot beam antenna, the size and design of the receiving horns, and the length of the interferometer arms.

3.2.2.2 Digitizing and Distributing Phase change Information-Mathematical Modeling

The coupling of the output of the interferometers to the portion of the phase control system that distributes phase change information to the phase comparators in each of the 5408 radiating modules is shown in Figure 3.5.

The output of the two interferometers is in the form of a dc voltage corresponding to their respective angular positions around the X and Y axis. The dc voltages are derived from precision potentiometers. The dc voltages are changed to digital signals that correspond to one-half the amount of phase shift that should take place between any two adjacent radiating modules in the X direction and in the Y direction to recenter the beam on the target.

These two digital signals, a and b, are distributed along the X and Y axes where they are multiplied by a whole number m ($2^{-1}/|m|$) or n ($2^{-1}/|n|$) corresponding to the row or column number, m or n , with $m = n = 0$ defining the Y and X axes. These signals are then sent along their respective rows and columns and at each radiating element where they converge are added together to become a change to the input of the digital phase shifter. The resulting phase change in the output of the digital phase shifter is then added to the clock phase reference to become the input to the phase comparator (Figure 3.3).

ORIGINAL PAGE IS
OF POOR QUALITY

HOW THE PHASED ARRAY IS STERED

Inputs to the X and Y microprocessors from the ground-based interferometers and the air vehicle-based position sensors are used to generate incremental phase shifts which must occur between successive columns and rows of radiating elements to steer the beam. These incremental phase shifts in digital form are multiplied by an integral number corresponding to the position of the row or column of the processing elements located along the X and Y axes. The resulting phase shifts in digital form are sent along the respective rows and columns. Another processing element located in each radiating element adds the two incoming phase shifts. The resulting digital signal is converted to an analog phase by means of a low-power 4-bit phase shifter and added to the "clock" or "boresighted" reference phase to provide a new reference phase by which the phase of the power emitted from the radiating element is controlled.

Although the phase shift increment between centers of adjacent radiating modules is of prime concern, the physical symmetry of the antenna around X and Y axes requires that the phase shift signal to the first radiating module correspond to only half a radiating module width, so that the sequence of phase shifts is a, 3a, 5a, and b, 3b, 5b, etc.

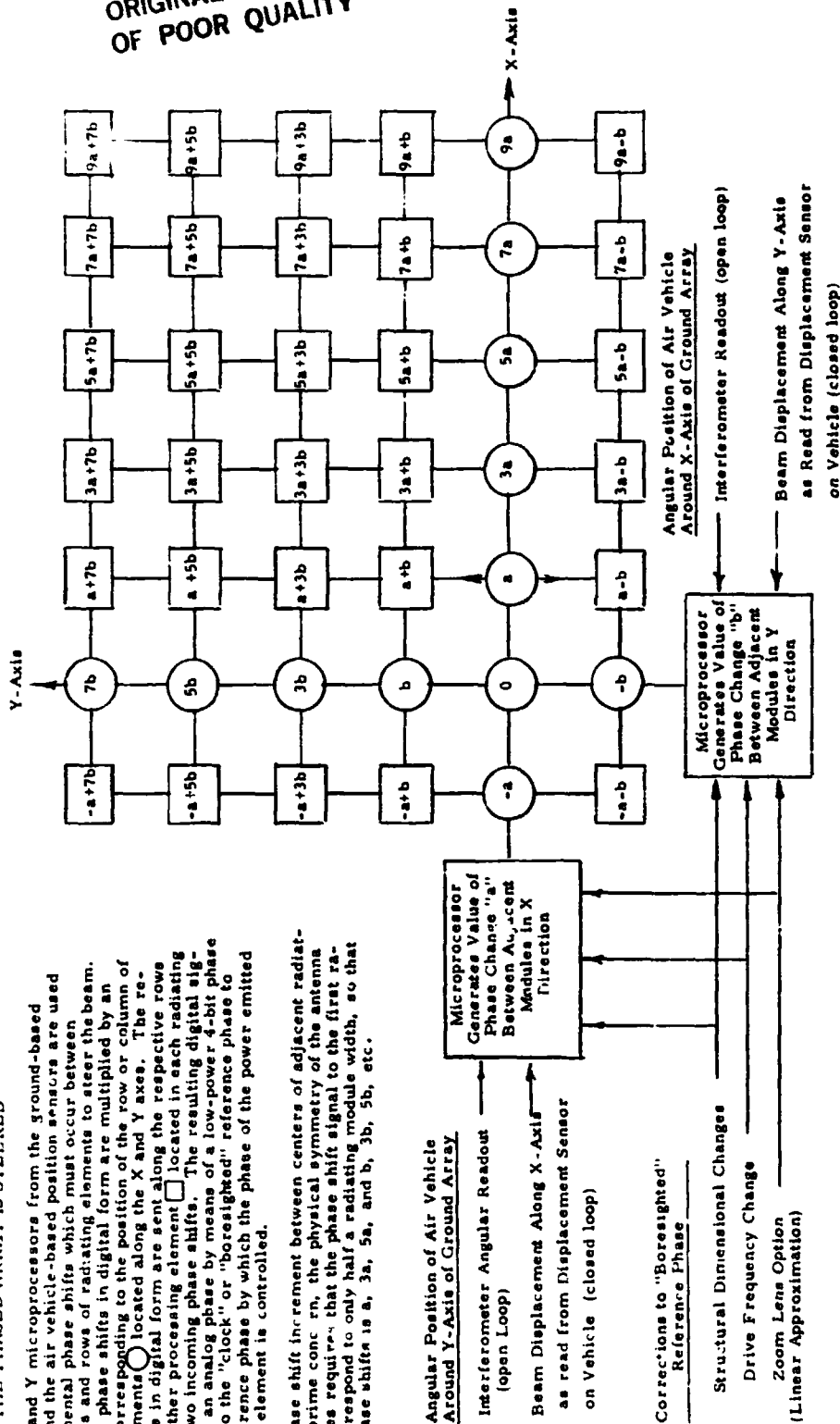

Figure 3.5 Phase Control Matrix Diagram Showing that Two Numbers, a and b, Derived from Interferometer Tracking Data, are Sufficient to Control the Pointing of the Array. Response of Array is Therefore Very Fast. Phase Control Matrix System can also be used to Approximate a Zoom Lens and to Make Corrections for Dimensional Changes Caused by Temperature Changes.

The arithmetic operations that occur at each radiating module could presumably be easily integrated into the digital phase shifter so that an additional, separate component for this operation would not be necessary.

It is recognized that the digitized phase reference signal will need frequent updating that corresponds to a changing position of the HAPP vehicle. However, the updating procedure is very fast because only two digitized signals, a and b, corresponding to changes in the two interferometer positions around the X and Y axes, respectively, are involved. Each radiating module does its own rapid arithmetic on the phase references. If the vehicle is moving at 20 meters per second, then the speed of updating need be no more than 20 times a second which could be easily handled by the proposed system.

The digitizing and distribution of the phase change information to the radiating modules may be mathematically modelled, as follows:

Let X be the long axis of the array

Let Y be the short axis of the array

Let n be the number assigned to the position of the radiating module on either side of the X axis and m be the number assigned to the position of the radiating module on either side of the Y axis. In the specific GMPTS design being proposed as a "reference" design, m runs from - 52 to +52, and n runs from -26 to +26.

Let α_m be the phase related to the column of modules parallel to the Y axis caused by tracking HAPP vehicle around the Y axis.

Let α_n be the phase related to the row of modules parallel to the X axis caused by tracking the HAPP vehicle around the X axis.

Then the phase of the mn th module is

$$\alpha_{mn} = \alpha_m + \alpha_n \quad (1)$$

The digitized phase shift signal, a , which travels along the X axis is given by

$$a = \frac{2\pi}{\lambda} \frac{l}{2} \theta_y \quad (2)$$

where θ_y is the rotation of the interferometer around the Y axis, and l is the separation distance between radiating module centers. The reason that $l/2$ rather than l is used is because the edges of the first module $m = 1$ and $n = 1$ are on the center lines (Y and X axes) of the array.

Likewise, the digitized phase shift signal, b , which travels along the Y axis is given by

$$b = \frac{2\pi}{\lambda} \frac{l}{2} \theta_x$$

where θ_x is the rotation of the interferometer about the X axis.

It follows then that the phase shift for $m = 1$ is a ; for $m = 2$ it is $3a$; for $m = 3$ it is $5a$; for $m = -1$ it is $-a$; for $m = -2$ it is $-3a$; etc.

This can be expressed mathematically as

$$\alpha_m = m \left(2 - \frac{1}{|m|} \right) a, \quad -52 < m < 52 \quad (3)$$

Likewise

$$\alpha_n = n \left(2 - \frac{1}{|n|} \right) b, \quad -26 < n < 26 \quad (4)$$

$$\alpha_{mn} = \alpha_m + \alpha_n \quad (5)$$

It will be recalled from Figure 3.3 that the phase of the power emitted by the mn th radiating module is the sum of the clock phase reference and the phase shift derived from the digital phase shift bus. Hence, any perturbation of the clock phase caused by temperature shift or other sources will impact the radiated phase and must be taken into account. Likewise, changing the focus of the beam will also change the outgoing phase. These two topics are handled in Section 3.2.5 and 3.2.4 respectively.

3.2.2.3 Distribution of Clock Phase Reference and Boresighting

One of the most interesting problems in this design study was how to implement the clock phase reference at each phase comparator site in the radiating module. Carrying this out in an appropriate manner is equivalent to boresighting the emitted microwave beam from the leveled face of the transmitting antenna on a focal point at 20 kilometers located at zenith.

This boresighting should be carried out so that it eliminates the effect of mechanical tolerances in the construction of each radiating module. In effect this means carrying out the calibration by comparing the calibrating reference phase with the phase of the emitted signal above the face of the radiating module. If possible, the calibration should also compensate for any vertical irregularities in the mechanical structure of the array, which implies that the output phase of the array be compared with the calibrating reference phase in an imaginary flat plane above the array. This flat plane can be established by a laser beam or other method.

The proposed calibration procedure makes use of the observation that the phase of the emitted power from a slotted waveguide module with an 0.75 meter side dimension is substantially uniform over a large part of its central area. That is, a probe mounted a short distance above the surface can be moved several wavelengths from the center without appreciable change in the phase of the emitted signal that it picks up. To check this, out phase measurements were made at a distance of 25 centimeters above the surface of the proposed radiating module shown in Figure 2.6 for a distance of 30 centimeters along both the vertical and horizontal axis and found to vary less than $\pm 5^\circ$. These measurements are further described in Section 4.0.

The second principle that is used, in combination with the constant phase above a radiating module described in the previous paragraph, is the use of a laser beam that is modulated with a 2.45 GHz signal. This modulated laser beam is emitted from a location at the center of the array and is aimed at a reflector mounted above one of the radiating modules, as shown in Figure 3.6 and in more

ORIGINAL PAGE IS
OF POOR QUALITY

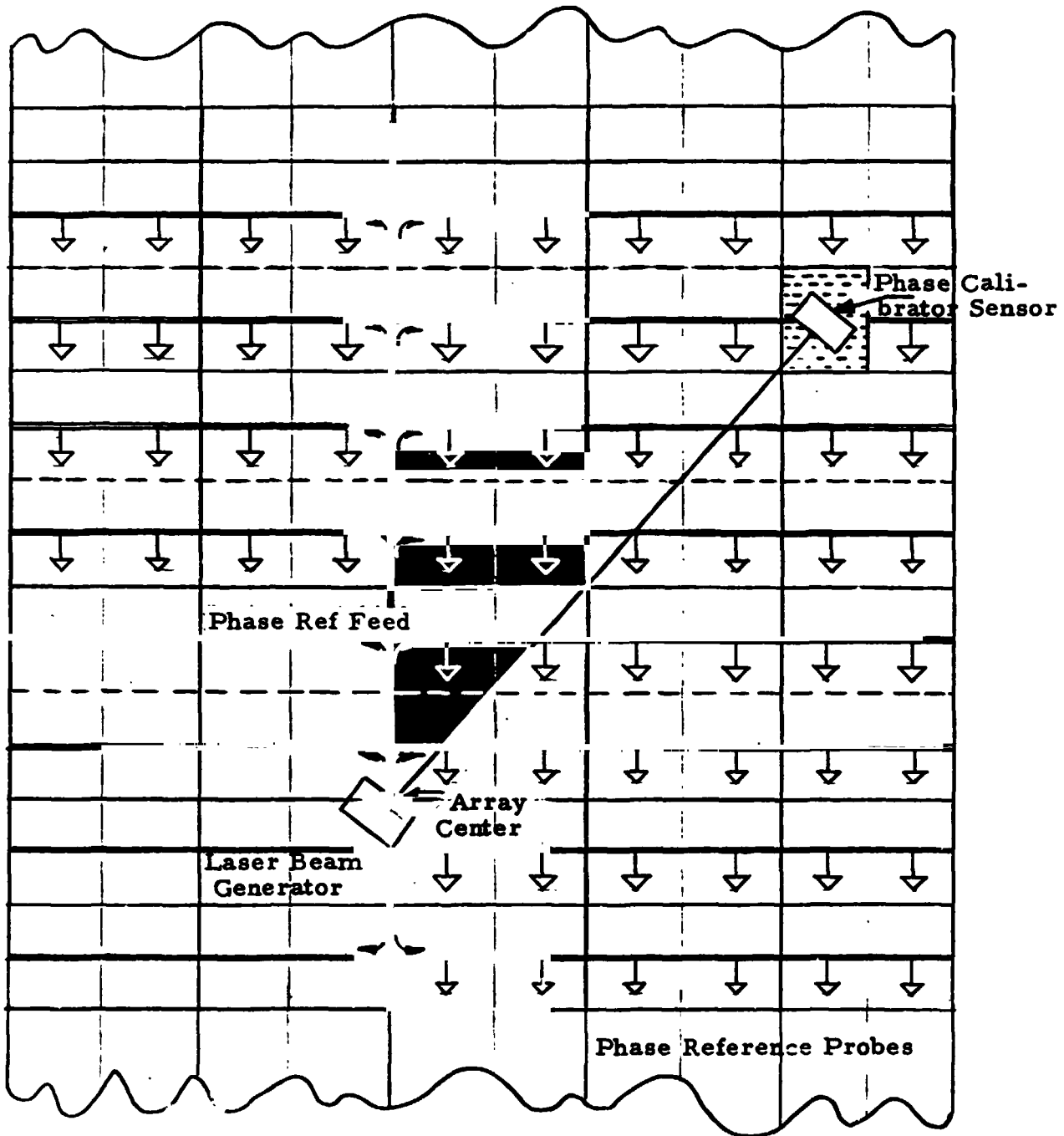

Figure 3.6 Diagram Showing: (1) Distribution of Clock-Phase Reference, and
(2) Arrangement for Use of Laser Beam to Boresight the Antenna.

detail in Figure 3.7. Most of the laser beam signal is reflected from the reflector to be demodulated at the origin of the laser beam but a small amount is coupled off at the reflector site and demodulated to become the calibrating reference signal. As shown in Figure 3.7, the reflector is moved in position until a null is obtained in a phase comparator which compares the phase of the 2.45 GHz modulating signal applied to the outgoing laser beam and the 2.45 GHz demodulated signal from the reflected portion of the beam.

If this same procedure is followed when moving the reflector from one radiating module to another, then all of the modules should receive the same calibrating reference phase for the phase comparison that will take place in a phase comparator located above the slotted waveguide array surface. This phase comparator is identified as phase comparator B in Figure 3.7.

The relationship between the calibrating reference phase obtained from the laser beam and the permanent clock reference phase is shown in Figure 3.6. The clock phase originates from the center of the array and is distributed by waveguide to all of the 5408 radiating modules. No attempt is made for mechanical precision in this distribution, but it is essential that once installed there is no lengthening or shortening of the distribution system without repeating the bore-sighting procedure. (Lengthening or shortening from temperature change can be compensated for; see Section 3.2.5.)

It is also convenient to have the laser transmitter at the center of the transmitting antenna although this is not essential. It is essential, however, that the face of the laser transmitter and receiver be placed over the center of rotation of the laser transmitter module and that it be close to the center of the radiating modules. (It is probable that in practice the laser will transmit and receive through the same port.) It is also essential during the calibration procedure that the source of a 2.45 GHz signal for the clock reference phase also be used for the 2.45 GHz modulating signal for the laser and that the 2.45 GHz transmission line length to the laser module be held constant throughout the calibration procedure.

ORIGINAL PAGE IS
OF POOR QUALITY

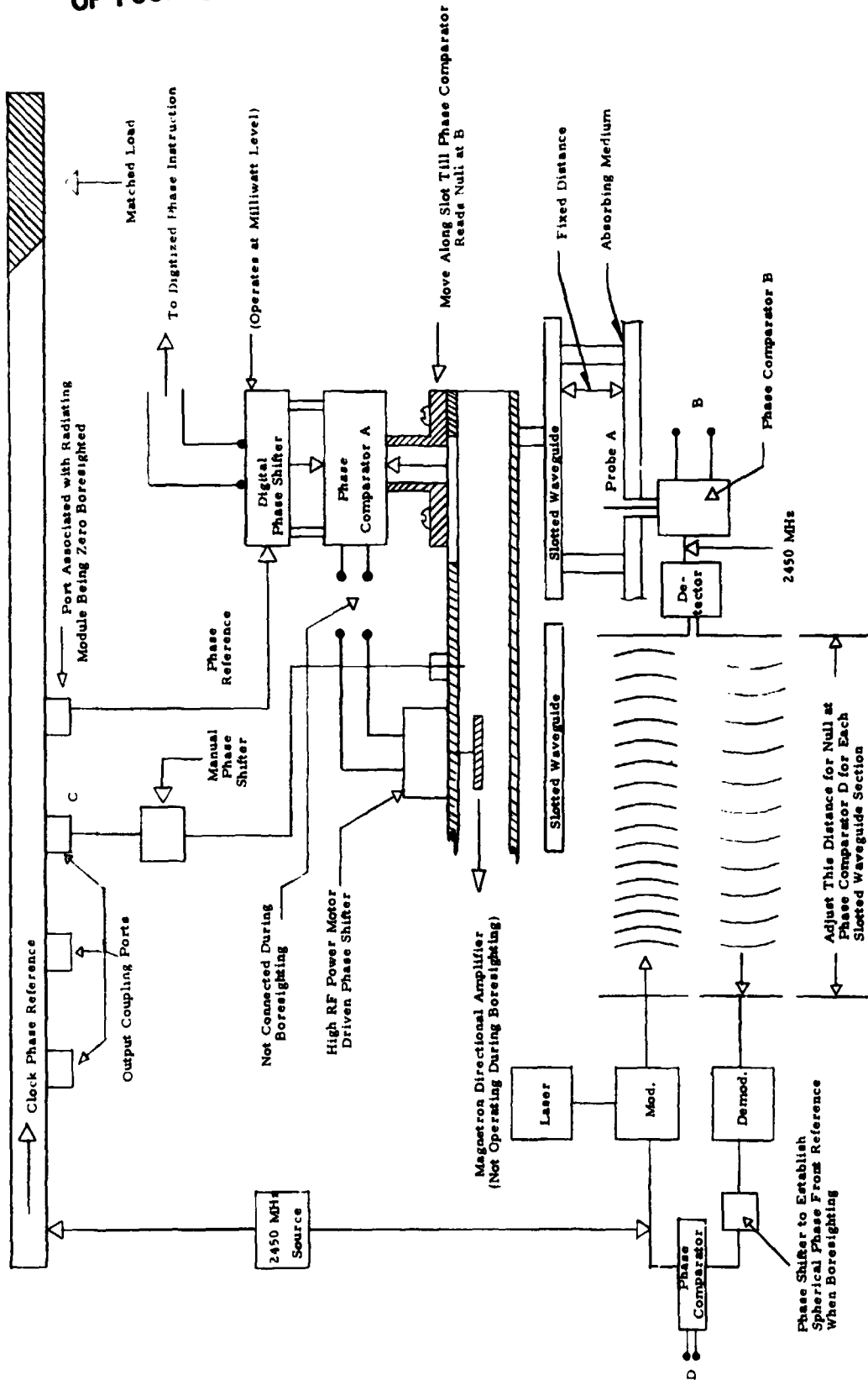

Figure 3.7 Diagrams Showing the Details of the Calibration Procedure in which All of the Radiating Modules are made to Radiate with the Same Phase. This is Equivalent to Boreighting the Antenna for Focus at Infinity. Focussing the Antenna on a Closer Point is made Possible by the Use of the Phase Shifter in the Laser Transmitter.

With the laser beam calibration reference system operating and the source of the clock reference signal turned on, we are now in a position to proceed with the boresighting. The calibration is accomplished without turning on the microwave power generation and distribution system. Instead, the clock phase reference distribution channel is used as a convenient source of 2.45 GHz signal, as denoted by the takeoff connection "C" in Figure 3.7 at the adjacent radiating module. A mechanical phase shifter is inserted in cascade with the cable connected to "C" and the other end of the cable is connected to a port in the waveguide that excites the radiating module and at a location which is after the mechanical phase shifter but before the probe to the phase comparator A that samples the phase of the power going into the slotted waveguide array.

The phase of the input signal from takeoff "C" is then adjusted by means of the auxiliary phase shifter to give a null signal in phase comparator B located in front of the slotted waveguide array. The final step in the boresighting is to then move phase comparator A along the waveguide so that there is a null in the output of phase comparator A. The phase comparator A is then locked in position. During this time the digital phase shifter is not excited.

An alternative to mechanically moving the phase comparator A would be to utilize a permanent memory in the digital phase shifter, and to introduce into this permanent memory a phase shift that would tend to null the output of the comparator. But a five-bit phase shifter has a resolution of 11.25° as compared to about 1° for the mechanical motion.

The calibration is then performed on the next radiating module until all 5204 have been phase calibrated and the entire array "boresighted". Although the procedure as described may seem involved, a three-man team could perform the boresighting rather rapidly. One man would aim the laser and read the 2.45 GHz signal null. Another, moving on the face of the transmitting antenna, would move the reflector and read the null in comparator B, while a third man, underneath the antenna would perform the necessary functions there.

The procedure just described, which would focus the antenna at infinity, needs a modification to establish the spherical phase front that is essential for focussing the beam at 20 kilometers. The spherical phase front is established in the boresighting procedure by the use of the phase shifter between the demodulated 2.45 GHz signal and the phase comparator, as shown in Figure 3.6. A relationship between the setting of the phase comparator and the radial distance of the radiating module from the center of the array can be easily established. The phase of the most outboard radiating module at $\sqrt{18.5^2 + 39.0^2}$ or 43.2 meters from the center needs to lead the phase at the center of the array by 137° so the correction is an important one.

The boresighting procedure has an ambiguity in it because the distance between the laser transmitter and reflector must be an integral multiple of λ or 0.1226 meter while the null indication from phase comparator D in Figure 3.7 will occur at integral multiples of $\lambda/2$. However, a surveying ranging instrument would resolve this ambiguity without difficulty.

This boresighting procedure can also compensate for surface distortions or irregularities if a laser leveling instrument is used to vertically locate phase comparator B in a flat plane above the surface of the transmitting antenna. This should not be necessary in a new structure but could be useful at later stages.

It may be useful to discuss the distortion of the phase front of the microwave beam as a function of the rotational position of the transmitting antenna. These distortions would come about as the result of a non level condition of the rails upon which the structure rests. Although the rails would be leveled before the structure was placed over it, they may need releveling at a later date. Then the overhead structure would prevent a direct releveling of the rails. However, the rails can be relevelled indirectly with the use of a laser leveling device and some point of reference on the superstructure of the transmitter located directly above the rails. This point should remain at the same absolute elevation for all angular positions of the transmitting antenna and the rails can be relevelled to bring this about.

The question arises as to the use of the laser calibration system during active operation of the transmitting antenna, when some part of the system has to be replaced, for example, the whole subarray which is the smallest unit that can be plugged in or removed. The question arises as to noise introduced into the laser system and the biological impact upon a man on the surface of the transmitting antenna.

It is first noted that the presence of men and the calibration equipment on the face of the antenna, and the non-operating status of the subarray will introduce a negligible perturbation into the performance of the system because of the large physical size of the array. As to the exposure of the individual to microwave power, the power density of the emitted beam will normally be quite low, consistent with a time averaged emitted microwave power level of between 40 and 100 kilowatts. At 100 kilowatts of radiated power, the power density would be 55 watts per square meter or only 5.5 milliwatts per square centimeter, about one half of the present continuous exposure value. If this value was felt to be too high, the operators could wear protective clothing. With respect to the calibrating equipment, the laser beam itself would be immune to microwave interference, and so it would be necessary only to adequately shield the 2.45 GHz portions of the calibrating equipment.

3.2.3 Retaining Polarization Alignment with Rectenna Rotation

Section 2.1.3 has reviewed the issue of maintaining polarization alignment between the transmitting and receiving antennas. The issue was resolved by assuming mechanical rotation of the transmitting antenna.

With this assumption, the retaining of polarization alignment with rectenna rotation consists of three parts. The first part is sensing when the linearly polarized microwave beam emitted by the GMPTS is not optimally aligned with the linearly polarized microwave rectenna. The second part is relaying the associated error signal from the sensor to the GMPTS. The third part is rotating the GMPTS to minimize the error signal.

The first part is simply done.^(2.8) Two dipole rectenna elements are mounted on the rectenna so that the dipoles are rotated 90° with respect to each other, and rotated 45° with respect to the dipoles in the rectenna array. The dc outputs from the rectenna elements are connected in a bucking or difference mode. When the polarization of the beam from the GMPTS is aligned with the rectenna, a null signal will result. If not aligned, an error signal is produced and this will be relayed to the ground station by a telemetering arrangement.

In the ground station the error signal will be used to rotate the transmitting antenna in a direction to realign the angular position of the transmitting antenna with the angular position of the rectenna.

In defining the overall control system, it is important to know the angular rate of rotation of the rectenna and the moment of inertia of the GMPTS. It is expected that the angular response time of the LTA-HAPP vehicle to any step function of force tending to rotate the vehicle will be relatively slow and also that there are no abrupt changes in the direction of the wind which would require a fast response time. The most rapid angular change would probably be when the vehicle would fly in circles to generate positive or negative lift, if that were required. Assuming the flight speed was 20 meters per second (approximately 40 knots), the angular rotation rate would be 0.0267 radian per second if the diameter of the flight path were 1.5 kilometers. The ground transmitter would be required to rotate once every 235 seconds or once about every four minutes.

It has been estimated that each subarray weights about 28 kilograms or about 12 kilograms per square meter. Hence, the entire GMPTS radiating and power generating structure weights 32,500 kilograms or 32.5 metric tons. A reasonable assumption would be that the supporting structure would weigh the same amount, for a total of 73,000 kilograms.

The radius of gyration of the structure, assuming evenly distributed mass, is 25.17 meters. The energy stored in the rotating mass at an angular velocity of 0.0267 radian per second to match the LTA circling speed is 16,384 Joules, or only 0.00455 kilowatt hours. Or, looking at the continuous power required to

accelerate the structure from rest, one kilowatt of power applied at 100% efficiency would accelerate the structure to full rotational speed in 16 seconds. It therefore appears that there are no significant technical problems or costs involved in providing the needed acceleration and deceleration of the transmitting antenna to retain polarization alignment with the rectenna.

3.2.4 Zoom Lens Capability

It may be desirable for a number of reasons to add a "zoom lens" capability to the active phased array. Among these reasons are (1) an ability to control the amount of power reaching the rectenna, independent of the level of microwave power radiated from the GMPTS (2) to maximize the aperture to aperture transfer efficiency, particularly if the flight level of the HAPP vehicle should change substantially for some reason and (3) for flexibility and adaptability of the GMPTS. These reasons will be explored in more detail.

In the GMPTS for the LTA-HAPP vehicle, the range of power required in the LTA varies by a huge factor. For a number of reasons it may be desirable at the lower power requirements to have the GMPTS radiate a fixed amount of power. If the focus of the GMPTS were fixed, then the excess power reaching the rectenna would have to be dissipated at the LTA in some manner. Although this should not be difficult, an alternative procedure is to defocus the microwave beam so that the power reaching the rectenna will be reduced to the point where no dissipation of power at the LTA is necessary.

With respect to maximizing aperture to aperture transfer efficiency, the LTA-HAPP vehicle which flies at nearly a fixed altitude would have little need of a zoom lens for this purpose. However, other HAPP vehicles could have a very definite need for a zoom lens capability. A helicopter, flying off a landing pad immediately over the GMPTS, would have the greatest need. But an airplane normally flying at 20 kilometers may find it desirable to seek appreciably higher altitudes during periods of high wind speeds to reduce its power requirements. This option is not available to LTA's because the displacement lift drops off so rapidly with altitude.

Finally, a zoom lens capability on the GMPTS would provide a standard GMPTS design with a high degree of flexibility in application that it would not otherwise have. This is especially important in the application of a new general technology area where the interactions of the various components of the system cannot be clearly foreseen.

The remarkable feature of the zoom lens capability in the conceptual GMPTS design is that it can be added at virtually no cost. As Figure 3.5 indicates, the zoom lens option consists of just an additional numerical input to the microprocessor. This input is processed by the microprocessor to create two multipliers of the outgoing digital signal that controls the phase of the radiating modules. One multiplier is slightly greater than unity while the other is slightly less than unity. If it is desired to focus the beam on a target at less than 20 kilometers distance (the antenna was boresighted for this distance), then the multiplier greater than unity is applied to the positive values of phase shift, which exist on one side of both the X and Y axes, while the multiplier less than unity is used to multiply the negative values of phase shift on the other side of the X and Y axes. The result is to increase the curvature of the outgoing phase front. On the other hand, if it is desired to focus the beam at a point greater than 20 kilometers away, the opposite procedure is used to decrease the curvature of the radiated beam.

It is noted that changing the focus of the antenna by this means provides only a first order correction, and that it may not be suitable for operating over a very wide range of focal distances, for example on a helicopter at close range. But it is probably quite satisfactory in optimizing the focussing of the beam on the LTA-HAPP vehicle and certainly as a means of defocusing the beam.

3.2.5 Correction for Temperature Expansion of the Array

An antenna of this physical size will be subject to sizeable dimensional changes as a function of the temperature of the array. If the supporting structure is steel, and the temperature range is 65^o centigrade, then the change in dimension from the center of the GMPTS to the furthest point from the center is 3.0 centimeters.

If the structure is boresighted at the center temperature of the 65° range, then the distortion that will have to be taken into account is ± 1.5 cm.

This expansion and contraction of the antenna will impact the phase reference because the conduit which propagates it will also expand and contract. However, its expansion and contraction will be slightly different because the reference signal is trunked along the Y axis with the side takeoffs running parallel to the X axis. Hence, we find that the maximum path length of the reference signal is the sum of 19.5 meters in the Y direction plus 39 meters in the X direction or 58.5 meters and the \pm change in length is 2.09 centimeters rather than 1.5 cm. This amounts to a $\pm 60^\circ$ shift in the emitted phase, rather than $\pm 44^\circ$ if thermal expansion were used directly.

To judge the impact of the shift in the reference phase caused by a temperature change upon the performance of the array, it is recalled, as noted in Figure 3.3, that the output phase of the radiating module tracks the sum of the reference phase and the digitized phase shift resulting from the tracking of the vehicle by the interferometer.

The change in the reference phase due to expansion or contraction from a temperature change is

$$\phi_m = |m| \left(2 - \frac{1}{|m|} \right) \frac{2\pi}{\lambda} \frac{l}{2} T_c \Delta t, \text{ where} \quad (1)$$

T_c is the coefficient of expansion for each degree of temperature increase, Δt is the temperature change, l is the dimension of the module, and m is defined in Section 3.2.2.2.

The expression for phase shift associated with interferometer tracking (expression 3 in Section 3.2.2.2) is

ORIGINAL PAGE IS
OF POOR QUALITY

ORIGINAL PAGE IS
OF POOR QUALITY

$$\alpha_m = m \left(2 - \frac{1}{|m|} \right) a, \text{ where } a = \frac{2\pi}{\lambda} \frac{l}{2} \theta_y \quad (2)$$

It is therefore possible to correct for ϕ_m by measuring the temperature of the array and making a calculated change in a equal to

$$\frac{2\pi}{\lambda} \frac{l}{2} T_c \Delta t$$

However, this correction will be subtracted from a on the positive side of the λ axis and added on the negative side of the X axis. Note that the sign of ϕ_m is independent of whether m is positive or negative but it is dependent upon the sign of the temperature change. Note also that the correction can be made by two multipliers, one slightly greater than unity and one slightly less.

If left uncorrected the impact of a positive temperature change is to focus the antenna at a nearer point while a negative temperature change focusses the antenna further away. The pointing will not be impacted.

In conclusion, it should be noted that the performance of the system, if left uncorrected, may not be seriously impacted by reasonable variations in the ambient temperature.

3.3 Microwave Power Generation and Distribution System

3.3.1 Introduction

The microwave power generation and distribution system is shown in schematic form in Figure 3.1. As indicated in Section 3.1, the array is made up of 1352 subarrays, each of which contains a microwave power amplifier and four radiating modules each with its own phase control. At full dc power output of 200 kW from the rectenna, the GMPTS is radiating 988 kilowatts of power when pointed at zenith, or 1176 kilowatts of power when pointed at the edge of 1.5 kilometer diameter confinement area for the LTA HAPP vehicle. This latter condition corresponds to a radiated power of 870 watts from each subarray or 217 watts from each radiating module.

However, the demand of the LTA-HAPP vehicle for such power is very infrequent and its average power requirements for propulsion may be only five kilowatts of dc power, corresponding to 25 kilowatts of radiated power. And for a substantial portion of time it may need even less for propulsion. These predictions are based on the assumption that the vehicle is not required to fly in circles to maintain altitude. There is therefore a need for a very wide dynamic range of power output of the transmitting array.

In the conceptual design, a dynamic range of at least ten can be obtained by programming the amplitude reference level in the 1352 magnetrons in the subarrays, although at the lower end of this range some external heater power to the filaments may have to be programmed. At the lower end of this level, the 1352 magnetrons in the subarrays may be turned off and a significant radiated power level maintained by feed through from the 104 magnetron directional amplifiers that are used as drivers. These 104 directional amplifiers operate with 500 watts of power output each for a total power of 52 kilowatts. However, waveguide losses and feedthrough losses in the ferrite circulators may cut the radiated power down to about 30 kilowatts. As we shall see later in the discussion, these driver amplifiers are being operated at the power gain level of about 50 so that their dynamic range is limited.

It is not possible to say at this time how smooth a transition there would be in the power output from all the 1352 final stages operating to all 1352 stages not operating. However, there are a number of options for making a smooth transmission over a very wide range of power demand. One of these is the use of the "zoom lens" feature of the transmitting antenna to diffuse the microwave beam at the rectenna. Another option is shutting off sections of the transmitting antenna which would further diffuse the beam. And, of course, it should be possible to dissipate excess dc power at the LTA in a comparatively simple manner.

It should also be noted that the lighter-than-air vehicle is unique among air vehicles in its ability to operate for much of the time at low powers. Airplanes and helicopters probably would not have more of a dynamic range than two to one, which would be adequately served by the control of output power in the final 1352 stages.

In the following discussion we will assume that the radiating of power in the range of 200 to 1176 kilowatts is the dominant element in the design of the transmitting antenna.

3.3.2 Configuration of the Microwave Driver and Final Amplifier Chain

For reasons having to do with matching the dynamic power range of the microwave oven magnetron to the microwave power radiating densities recommended by cost minimization procedures (Section 2.5.3), and for reasons having to do with the maximum permissible physical size of the radiating module that is related to the loss of power density of the microwave beam as it follows the HAPP vehicle off zenith (Section 2.5.5 and Figure 2.16), it was found necessary

to have one magnetron directional amplifier drive four radiating modules. Thus, Figure 3.1 shows one magnetron directional amplifier represented by a dot, for a set of four radiating modules. Spreading the area represented by one subarray over four radiating modules each with its own phase control reduces the power density loss at a 3° angle off zenith from 68% to 28% (Figure 2.2). Using one magnetron over the complete subarray area allows it to operate properly over a much wider dynamic range than if one magnetron were used for each radiating module.

Having established the number of final-stage magnetron directional amplifiers (one for each of the 1352 subarrays), it is necessary to consider how they will be driven. In particular, it is desired to know the number of stages of amplification that will be necessary. This depends to a large extent upon the amount of power gain that can be obtained from each stage of amplification which in turn depends upon the power output range over which the magnetron directional amplifier will be required to operate.

The 1352 magnetron directional amplifiers in the final stage of amplification are required to operate over a wide range of power output. Under these circumstances, as described in Section 2.4.2.1, the amplifiers should operate at low power gain. It would be logical then to have thirteen magnetron directional amplifiers, the number that appear on each side of the X axis centerline of the transmitting antenna, driven by one magnetron directional amplifier. For good life considerations (Section 2.4.2.2 and Figure 2.11), the drivers should operate at 500 watts of power output, supplying 35 nominal watts of power to each final amplifier. Under these conditions, the final amplifiers could operate over a very wide dynamic range, with one kilowatt of power output being the top of the range. Although the life expectancy of the microwave oven tube, as discussed in Section 2.4.2.2, would be 8000 hours at the kilowatt level, the LTA vehicle would require such power only infrequently. At a likely level of average power, the life would be ten years or more. As Section 2.4.2.2 points out the magnetron automatically adjusts the temperature of its cathode for maximum life at any level of microwave power demanded from the tube.

Unlike the final stage of amplification, the intermediate levels of amplification can be operated at constant power output and therefore at a relatively high gain level. Each of the intermediate stages should be able to operate at a power gain of 100 or 20 dB, if the power output is held constant at 500 watts, as it would be with the amplitude control system described in Section 2.4.2.1. Thus, it is possible to excite the 52 drivers on either side of the Y-axis centerline of the structure with one amplifier.

The amplifier chain then takes the form shown in Figure 3.8. It is noted that only three stages of amplification are necessary. If each first stage is driven with a very conservative value of 20 watts, then the total power gain when the system is radiating its maximum power of 1176 kilowatts is 29,400 or 44.7 dB.

The redundancy aspect of the active phased array is a great advantage. If one of the final amplifiers is lost, the overall performance deteriorates only slightly, and the amplifier may be replaced at leisure. Even if one of the 2nd stage amplifiers fails and along with it the 13 tubes in the associated final stage, the overall performance will not degrade markedly and the amplitude power control circuit can instantaneously make the necessary adjustments to keep the rectenna supplied at the pre-existing power level.

However, if one of the 1st stage amplifiers fails, the power density at the rectenna will decline by a factor of at least four. Therefore, it is necessary from a reliability point of view to have standby 1st stage amplifiers, and of course a standby exciter.

3.3.3 Details of Microwave Drive Power

Figure 3.1 shows that the 52 2nd stage amplifiers are all driven from power flowing down a long transmission line. If equal power is supplied to each 2nd stage amplifier, and if the transmission line is terminated at its output end with a matched load, there will be an exponential decay of power along the length of the guide. If directional couplers are used as a conventional means to divert

ORIGINAL PAGE IS
OF POOR QUALITY

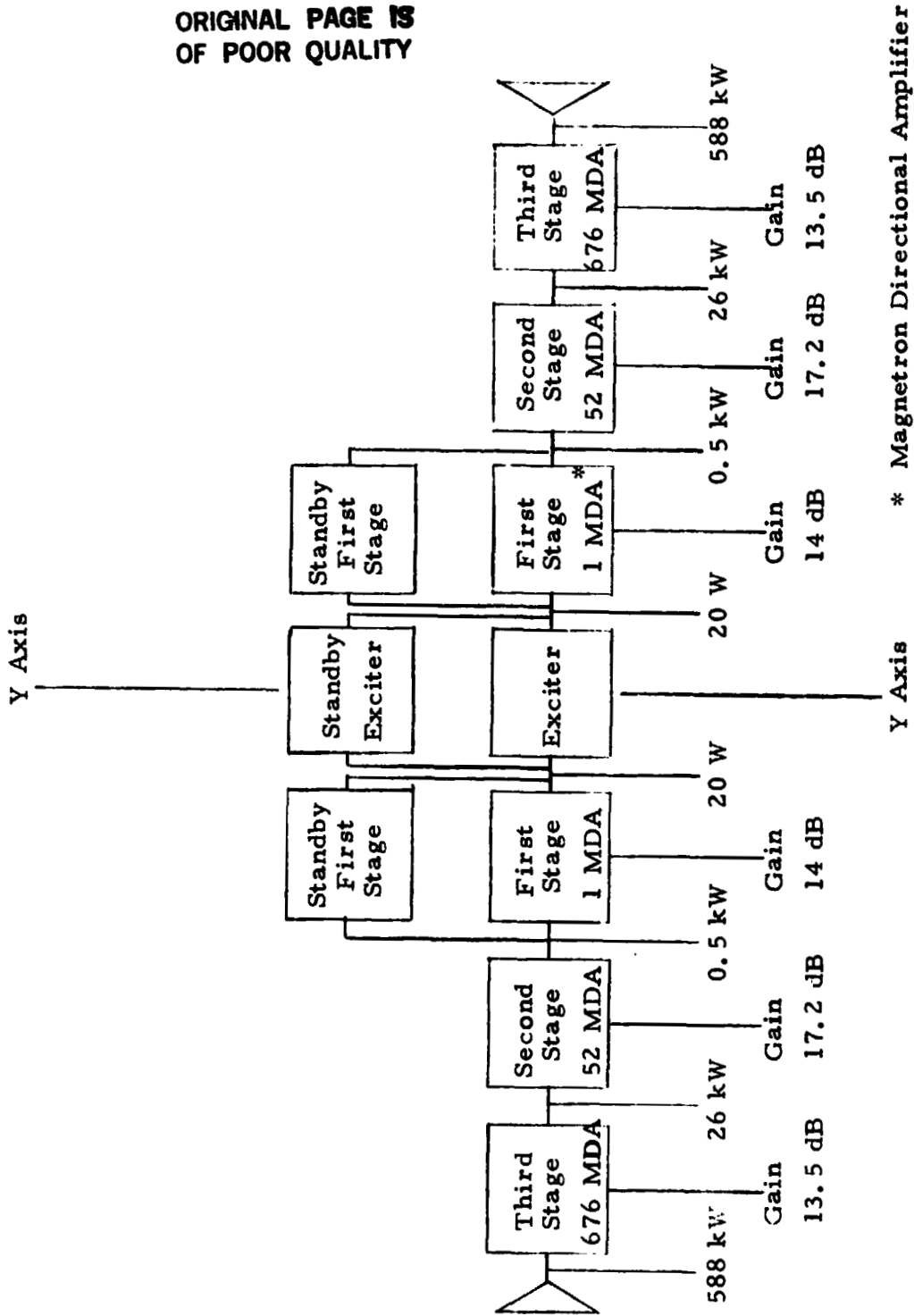

Figure 3.8 Schematic of Microwave Power Subsystem Showing Final Stage and Two Driver Stages as Deployed on the X-Axis of the GMPTS in Figure 3.1

the power from the main guide, then it would be logical to make the last coupler a 3 dB coupler to split the remaining power in the line between it and the termination. On the other hand, the first coupler would divert 25 watts from the initial 500 watts to feed the first two stage amplifiers (one on either side of the X axis). It would therefore be a 13 dB coupler. Because the excitation level of the second stage amplifiers is not critical, 20 different couplers with 20 different coupling values would not be necessary. The level of detailed design in this study is not sufficient to optimize the selection of directional couplers.

It should be emphasized that the phase of the power coupled out is not important as long as it does not vary rapidly in time, or more specifically, at a rate faster than the mechanical phase shifters in the radiating modules can compensate for the phase change. Intuitively, there should be no reason for phase change since the system operates at one single highly stabilized frequency and the directional couplers eliminate most of the impact of reflected power, which in any case should be minimal because of the high degree of impedance match that can be maintained, again because of the single frequency nature of the system.

As Figure 3.1 also shows, each of the 2nd stage amplifiers drives a number of final amplifiers (ten in Figure 3.1 but actually 13 in the reference design). Each of the final amplifiers is excited from a long waveguide transmission line, also through a directional coupler and in a manner similar to the excitation of each of the second stage amplifiers.

To guard against the impact of a change in the position of the mechanical phase shifters upon the magnitude and phase of the reflected power at the terminal end of the power distribution chain, the phase shifters in the radiation modules are buffered by ferrite circulators with a load termination on the third arm to absorb any reflected power.

3.3.4 Design of the Microwave Subarray

The subarray, for a number of reasons, is one of the principal focal points of the design. Here, the support functions of clock phase reference,

digitized information to change pointing direction, microwave drive, and dc power are integrated into the purposeful functions of microwave power generation, and the control of its output phase and amplitude in accord with overall system needs. Here is the principal element of hardware cost in the transmitting antenna, and an opportunity to examine the details of this cost, and how they can be minimized from a mechanical design point of view.

At the conceptual level of design, the design of the subarray is well defined. With one exception, it is ready for the next step in design, that of making detailed drawings and constructing a subarray for testing and experimental evaluation. The one exception is the design of the mechanical phase shifter to be discussed later.

Because it is so far advanced conceptually, the best manner in which to discuss the subarray and its connections with outside services is from a mechanical structure point of view. When looked at in this manner, it is found that the principal subassemblies are the (1) slotted waveguide arrays subassembly, (2) the power distribution and phasing subassembly, and (3) the magnetron directional amplifier subassembly. These subassemblies and the overall subarray will be discussed with the aid of Figure 3.9 and Table 3.2.

Table 3.2 is useful in indicating the components that go into the three subassemblies and to what supporting services external to the subarray the components interface with. This same table will be useful in estimating the cost of the subarray. The three different subassemblies will be discussed individually in the following material.

3.3.4.1 The Slotted Waveguide Array Subassembly

This assembly consists of four slotted waveguide sections of a design that was jointly developed by Raytheon and JPL^(2,6). The electrical design is essentially that of JPL, slightly modified by Raytheon to adapt it to a novel fabrication method devised by Raytheon to produce slotted waveguide assemblies from folded thin sheet metal at very low cost. Slotted waveguide arrays made

ORIGINAL PAGE IS
OF POOR QUALITY

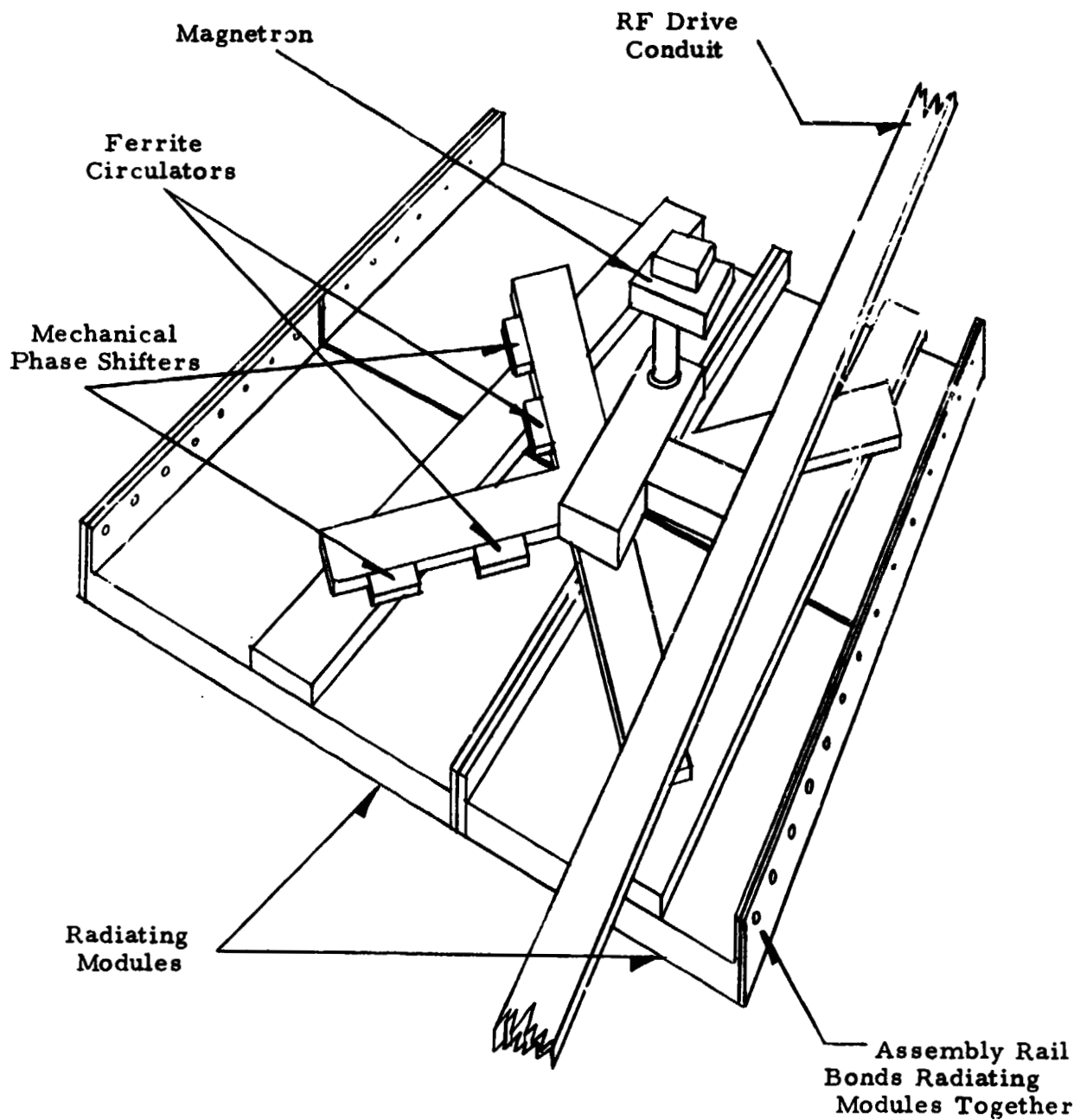

Figure 3.9 Subarray Assembly as Viewed from the Back
(Non-Radiating) Side

TABLE 3.2

Major Subassemblies in Subarray	Major Components of Subassemblies	Number of Components	Service Functions External to Subarray	
Slotted Waveguide Array Assembly	Slotted Waveguide Sections	4	None	
Power Distribution and Timing Subassembly	X-Waveguide Fabrication	1		
	Ferrite Circulator Parts	4		
	Phase Shifter Parts	4	Fixed Phase Reference Matrix (Clock Phase)	
	Phase Comparators	4	Digitized Beam Steering Matrix	
	Operational Amplifiers	4	± 12 volts dc for control circuits	
	Digital Phase Shifters	4		
	Arithmetic and Informator Storage Unit	4		
Directional Amplifier	Modified Magnetron	1		
	Ferrite Circulator with Resistive Load	1	Microwave Drive Matrix for Magnetron Amplifiers	
	Amplitude Comparator	1	3500 Volt dc Power Matrix for magnetron power	
	Operational Amplifier	1	Amplitude Instructional Matrix for Microwave Power Control	
	Filament Transformer	1	± 12 volts dc for control circuits	
	Cooling Fan	1	60 cycle - 110 volts for filament	
	Magnetron Start-Stop Logic	1		
	Fuse	1		
	100 Ohm Resistor	1		

ORIGINAL PAGE IS OF POOR QUALITY

by this method were checked by JPL on their antenna range and found to be quite satisfactory. Somewhat by coincidence, the size of this array (0.75 meter on each side) meets the requirements imposed upon the radiating module area by the HAPP vehicle application. (See Section 2.1.4.) We have therefore used it directly in the conceptual design.

The method by which the slotted waveguide sections are made is discussed in Section 2.4.1.2 and illustrated in Figures 2.4-2.7. Both the material cost and the labor cost are low in this fabrication method. The weight of the total amount of 0.020-inch thick aluminum used in one of the sections is 2.6 kilograms. This corresponds to 4.6 kilograms per square meter or 14,000 kilograms for the 39 by 78 meter array. The cost of the material at 1982 prices would be approximately \$20.00 per square meter or \$60,000 for the entire antenna. With the degree of tooling that is consistent with making such sections in very large quantities, the labor per section could be held to about one hour per square meter. As indicated in Figures 3.1 and 3.9, four sections are needed for one subarray. These can be readily assembled into a self-supporting structure by taking advantage of the rolled over lip shown in the assembly in Figure 2.4, to which an angle or strap is attached, as shown in Figure 3.9.

3.3.4.2 The Power Distribution and Phasing Subassembly

The purpose of this assembly is to distribute the power from one magnetron among four radiating modules, and to change the output phase of each radiating module in accordance with the demand of the vehicle to repoint the microwave beam. It is necessary to have this assembly because of the assumed distance of 0.75 kilometer that the vehicle may be off zenith when it repoints itself into the wind or when it has to fly in circles to compensate for the diurnal variation in the lift of the vehicle. If this required distance were halved, then one magnetron could serve one radiating module and the power distribution and phasing subassembly could be completely eliminated and there would be substantial cost savings, as indicated in the cost analysis procedure in Section 2.5.5.

As shown in Figure 3.9, this subassembly consists of an X-shaped section of waveguide into which various functions are inserted. The X-shape is fed in the middle by a probe from the magnetron directional amplifier. Each of its four arms are terminated with a section of slotted waveguide. In each arm of the X there is a motor driven mechanical phase shifter buffered by a ferrite circulator whose function is to prevent any reflected power from the phase shifter from getting back into the microwave drive system.

The assembly discussed in the previous paragraph is engineered as a single component to eliminate what would otherwise be a costly assembly of four separate mechanical phase shifter components, four separate ferrite circulators, and a power divider. Such an assembly of separate components would involve sixteen waveguide flanges alone. In addition to very large cost savings in construction, the integrated structure will simplify testing procedures. The expected cost of these units is included in Section 3.5 but the technology associated with the ferrite circulator and phase shifter should be discussed here.

The ferrite circulator design proposed is based upon a very low cost design that has been used successfully in commercial (as distinguished from home) microwave ovens. It is the Microwave Associates 3K315 D72007-1. As a separate component it has sold for a price below \$20. But the critical parts, small ferrites and small permanent magnets would represent only a fraction of the total cost of the ferrite circulator and these would be mounted directly in the X structure.

In contrast to the "immediate" availability of the ferrite circulator design, the mechanical phase shifter would have to be designed, although it is believed that the approach is reasonably well defined. In this approach, a substance with a high dielectric constant is moved parallel to the wide dimension of the guide. In its position at the side of the guide it is out of the electric field in the guide so that it has little effect, but in the center of the guide it can have a very large effect and will shorten the guide wavelength dramatically. The minimum amount of phase shift that is necessary is 360° , so that it is desirable to use a material that has a high dielectric constant to keep the length of the waveguide section

devoted to the phase shifter to a minimum. The use of such a material may provide matching problems at the input to the phase shifter so that some power may be reflected. A major purpose of the ferrite circulator is to absorb any such reflected power.

A small dc motor is required to change the position of the dielectric in the waveguide. This motor is a component in the phase control system that involves the phase comparator and a feedback loop to excite the motor to change the position of the phase shifter to cause a null to be reached in the phase comparator.

The feedback control system that accomplishes the phase control was thoroughly tested out in the effort under contract NAS8-33157 and is described in reference 2.4. This testing included the use of a motor driven mechanical phase shifter, but the phase shifter was of a coaxial trombone type and would not be suitable in this application.

It may also be pointed out that the maximum power flow through the phase shifter would be only 217 watts. This fact allows a wide selection of materials to be considered for the dielectric.

3.3.4.3 The Magnetron Directional Amplifier Subassembly

As shown in Table 3.2, the magnetron directional amplifier assembly consists of a modified commercial microwave oven magnetron, a ferrite circulator, an amplitude comparator, operational amplifier, a filament transformer, a cooling fan, and a magnetron start-and-stop logic center.

The ferrite circulator is of a low cost design previously referred to and identified as the Microwave Associates 8K315 D72002-1. The magnetron is a conventional off-the-shelf low cost microwave oven magnetron which has been externally modified (vacuum not broken) to (1) couple it tighter to the load, (2) place it on frequency exactly at 2.45 GHz, and (3) equip it with a small buck-boost

coil for (a) control of its microwave output power level and (b) for assisting with filtering of the rectified dc power. Because of its importance in establishing the credibility of the use of the magnetron directional amplifier, a special effort was made under this contract to experimentally modify and then test the microwave oven magnetron. This successful effort is reported upon in Section 4.0 of this report. The resulting modified tube is shown in Figure 2.10.

The magnetron directional amplifier is wired into the system, as shown in Figure 3.10. It makes nearly direct contact with the dc power bus through a high voltage fuse and a 100-ohm 50-watt resistor. It thus avoids the power losses and the costs involved in a conventional power conditioning unit. The conventional power conditioning is replaced by a more flexible system which allows the tube to adjust itself automatically to a change in applied dc voltage or allows it to respond to a command calling for a change in power output. This feedback control loop makes use of a power sensor, which converts a few milliwatts of the power output into a low voltage which is then compared with a reference voltage. If there is a difference, an error voltage is introduced into an amplifier whose output changes the current in a buck-boost coil, which in turn adds or subtracts to the field established by the permanent magnet. The power required for the buck-boost coil is less than ten watts, so the requirement imposed upon the operational amplifier is minimal.

Detailed data on the operation of the magnetron tube specifically modified for potential use in the GMPTS is discussed in Section 4.0.

3.3.4.4 Magnetron Starting, Stopping and Protection from Arcing

During normal operation of the magnetron, the filament of the tube is heated indirectly by electron bombardment and so it does not require an external source of heater power during normal operation. However, it does require external power for about five seconds to heat up the filament during start-up operations. But during that time, anode voltage should not be applied because there is a tendency to arc if the filament is not supplying adequate emission, and because the noise level could be relatively high during the start cycle.

ORIGINAL PAGE IS
OF POOR QUALITY

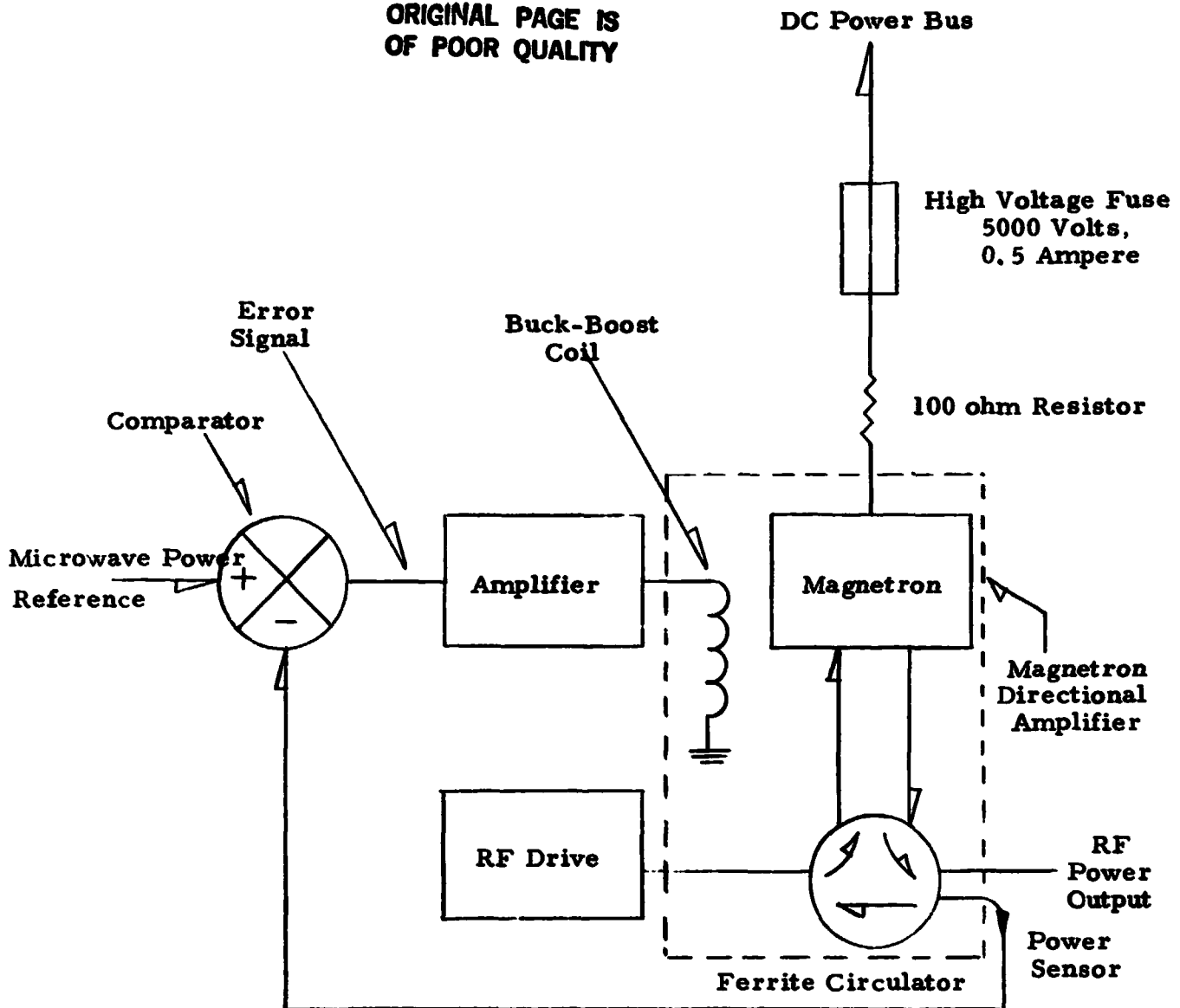

Figure 3.10 Schematic Showing (1) How Directional Amplifier Functions to Adapt Itself to a Changing Line Voltage While Producing a Prearranged Amount of Microwave Power Output, and (2) How It is Wired into a Common DC Power Bus.

Therefore, the starting sequence that is used and which has been experimentally evaluated as being satisfactory (Page 3-1 of reference 2.4) is as follows:

(1) The dc voltage is applied to the magnetron which has a cold cathode and cannot be started in that condition.

(2) The magnetic field on the tube is elevated by an artificial reference voltage to a value that will not allow the tube to draw anode current and start when the filament is turned on and heated.

(3) The filament power supply is then turned on to heat up the filament. About five seconds is required.

(4) The filament and artificial reference voltage are then turned off and simultaneously the reference voltage that controls the steady state amplitude of the microwave power output is applied.

(5) The resulting transient period to achieve normal operation is of the order of a few milliseconds.

Attention is called to the use of a representative commercially available high voltage fuse, rated at 4800 volts and 0.5 ampere, which is used to take care of the situation in which there is a sustained arc in the tube. This fuse is the "Shawmut" type PT fuse., Cat. No. A480T 1/2 E. Although arcing in well processed and evacuated tubes is not anticipated, there may be situations in which the tube may have a slow vacuum leak in it and eventually reach the point where an arc will occur. Under these circumstances it is necessary to remove the tube from the dc line.

3.4 The Conversion of 60-Cycle Power at the Utility Connection into DC Power for the Magnetrons and for Other Power Requirements

This discussion will concentrate upon the conversion of 60-cycle power into dc power suitable for use by the magnetron directional amplifiers. Although 60-cycle power is used for other purposes, such as cooling fans and to supply filament power to the magnetrons on start up, these requirements are not central to the conceptual design of the GMPTS.

One of the issues that could arise in a situation where there are many relatively small microwave generators distributed throughout a large array is whether to run the 60-cycle power to the individual tube sites (or to a conclave of such tubes) and there convert the 60-cycle into dc power or whether to have a centralized source of dc power and bus the dc power to the various sites. In the example of hundreds of magnetrons used in some microwave industrial processing equipments, each magnetron has its own power supply which operates from a 110-volt, 60-cycle ac bus. This approach was taken for a number of reasons but largely because a 60-cycle, 110-volt plug-in power supply for the home microwave oven was already in large volume production and had reached a very low unit cost. Further, the supply took care of a considerable line voltage variation without causing unreasonably large variations in microwave power generation. The rectifier is a half-wave rectifier so that the output power is essentially interrupted dc power. But this is acceptable for a home microwave oven and for industrial processing.

Such a supply, however, is not suitable for the GMPTS application because any variation in current through the magnetron directional amplifier is converted into a variation in the phase of the output, so that the GMPTS requires a continuous dc power source with relatively low ripple. Such a source appears to be much more easily achieved by having a central source of dc power with relatively low ripple achieved by means of a three-phase full-wave rectifier and a wave filter to reduce the ripple. The use of a common dc bus for all magnetrons operating in parallel from it is made possible by use of the amplitude comparator circuit in the output of the magnetron and a feedback control system that utilizes a buck-boost coil that allows the tube to accommodate itself to a dc bus that is seen as a highly regulated constant voltage power source by an individual tube. The use

of this arrangement is discussed in Section 2.4.2.1.

Although the centralized dc power supply had been selected for the reference design of the GMPTS, cost estimates that were made in the latter stages of the study relative to the cost of a centralized dc power supply are several times larger per kilowatt of microwave power generated than the cost utilizing a microwave oven power supply. In fact, the estimates which were provided by a professional power engineer are so much greater as to upset the design as well as the cost of the GMPTS, which were essentially based upon the cost of the power supply and tube for the microwave oven with a substantial amount added for a ripple filter. The impact, using cost minimization procedures, is to increase the area of the transmitting antenna and to reduce the amount of microwave power radiated by the transmitting antenna and the amount of 60-cycle power used.

This disparity in estimated costs has the effect of reopening the issue of centralized versus decentralized 60-cycle to dc power conversion. Another reason for reopening the issue is that if a centralized dc power source is used, 60-cycle power still has to be distributed throughout the array for other purposes such as cooling fans, heater power, and electric lights. An alternative procedure would be to distribute all 60-cycle power at about the 480-volt level.

If this alternative option were studied, then it is possible to visualize a three-phase, full-wave rectifier power supply for each magnetron with its low ripple output, a procedure now impossible for the home microwave oven because of the unavailability of three-phase power in homes. Such an arrangement would reduce the ripple to the point where minimum passive filtering would be required because of the active filtering that the buck-boost coil and its associated amplitude control circuit provides.

A simplified diagram of the components and their interconnections for a centralized dc power supply is shown in Figure 3.11.

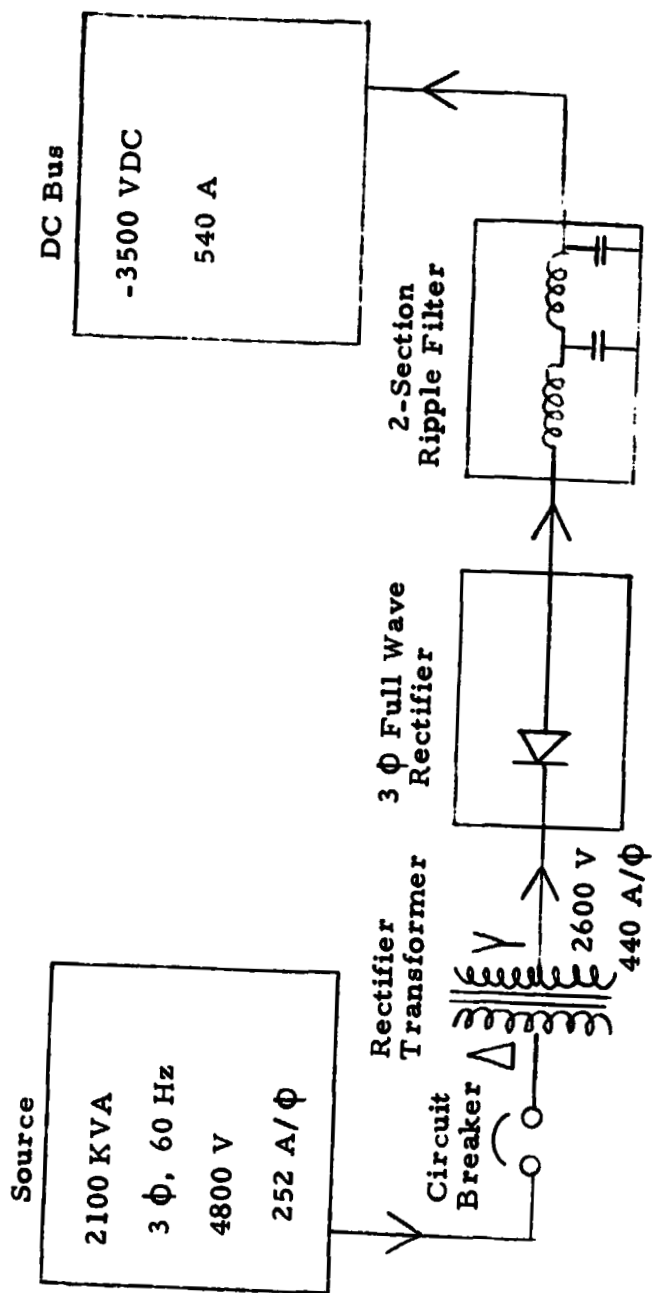

Figure 3.11 Circuit Diagram of Centralized DC Power Supply for GMPTS

3.5 Estimated Costs for the GMPTS and Their Significance in Design Reiteration

For discussion purposes, how can the estimated costs associated with the GMPTS be characterized? First and foremost they are important. They are important in helping to determine whether the system will be competitive with other approaches to providing the same functions and therefore whether developing an initial system will be worthwhile. Secondly, they are characterized by their dependence upon the general technical approach that is taken. Third, they are influenced greatly by how the details of the general technical approach are carried out and this in turn involves a great deal of recycling of the design details to achieve economies through integration, elimination, scale of production, etc. Fourth, and finally, understanding their significance has a strong dependence upon the use of mathematical modelling and cost minimization techniques.

In the context of the foregoing discussion, the design of the first iteration of the GMPTS was based upon mathematical modelling and cost minimization techniques and initial assumptions that were made with respect to the components of cost going into the equations. This section estimates the costs based upon that design which can then be used for a reiteration of the design, although that reiteration was not undertaken.

The costing of an entity is usually done in terms of its physical structure and components. The equations for cost minimization, on the other hand, are expressed either in terms of the cost of components and substructure to generate the microwave power, or in terms of the cost of the structure and components that form the microwave beam. To reconcile the two procedures, it is necessary to decide what items of structures and components go into the two categories of cost. Although the decision is usually clear cut, that is not always the case. For example, the subarrays contain individual items of both categories that can be easily separated out, but the assembly of these components into the subarray represents a cost allocation problem. Disregarding such fine structure of cost allocation, the assignment of sources of costs to the two cost categories are given Table 3.2.

When this classification is performed, it is found that in each category there are some fixed-cost elements that do not vary with the size of the antenna

CLASSIFICATION OF GMPTS COST ITEMS

<u>Cost of Forming Microwave Beam</u>	<u>Cost of Generating Radiated Microwave Power</u>
Position of Subarray Associated with "a"	Portion of Subarray Associated with "m"
Slotted Waveguide Radiators	Magnetron Directional Amplifier
Waveguide Phase Shifters	Ferrite Circulators
Digital Phase Shifters	Cooling Fan
Phase Comparators	Filament Transformer
Operational Amplifiers	Resistor and Fuse
Arithmetic and Storage Unit	Waveguide Plumbing
Vehicle Tracking and Beam Pointing Instruction	Conversion of 60 Cycle Power to DC Power
Interferometers and Tracking Loops	Distribution of DC Power and Other Power
Analog to Digital Conversion	Radio Frequency Drive Matrix
Digitized Phase Distribution Matrix	Amplitude Control Matrix
Clock Phase Reference Distribution Matrix	
Supporting Structure (Non-Rotating)	
Site Preparation	

Table 3.2

or the amount of microwave power used. For example, the cost of the interferometers and associated gear is independent of the size of the antenna.

With the qualification that the individual estimates of cost are far from accurate in many cases, Table 3.3 provides cost estimates for these two categories of cost in a production unit as defined in Table 3.3. The two categories of cost are found to be approximately equal, and the total production cost is \$2,647,800.

If the values of "a" and "m" are then computed on the basis of the antenna area and maximum microwave radiated power of the GMPTS design as given in Table 3.1, these values of a and m are found to be \$440/meter² and \$1,110/kW. These values of a and m, particularly that for m, are considerably higher than the values assumed in Section 2.5.5, and may be interpreted as the findings of the costing of the first design iteration. Before proceeding to rationalizing these differences and their implications for a design reiteration, it may be noted that if these values for a and m are substituted into equation (5) of Section 2.5.2, it is found that the antenna area A_{tm} is equal to 2746 meters² or approximately that of 3042 meters² for the GMPTS reference design of 3042 meters². This area was originally arrived at, however, on a life cycle basis where some energy cost has been included.

It is obvious from the findings of these cost estimates that the production cost of less than \$50 for the microwave power supply in a microwave oven, even after it is multiplied by a factor of 4 cannot be used as a guide to the cost of the GMPTS power system. On the other hand, a cost of \$1,110 per kilowatt for power seems excessive. This matter is discussed further in Section 3.4. It seems clear that any design reiteration should give high priority to alternative approaches to the 60-cycle to dc power conversion and power distribution which represents nearly half of the cost of the microwave power.

With respect to the cost of forming the microwave beam, the digital phase shifters, phase comparators, and digitized phase distribution network are important elements of cost. The number of these devices and matrix complexity can be cut down by a factor of four by sampling output phase in only one of the four

TABULATION OF MAJOR GMPTS PRODUCTION COST ITEMS * **

<u>Cost of Forming Microwave Beam</u>		<u>Cost of Generating Radiated Microwave Power</u>	
Subarray Portion	\$540, 800	Subarray Portion	\$507, 000
Vehicle Tracking and Beam Pointing Instruction	\$150, 000	Conversion of 60 Cycle Power to DC Power	\$400, 000
Clock Phase Reference Distribution Matrix	\$ 50, 000	Distribution of DC Power and Other Power	\$200, 000
Supporting Structure (Non-Rotating)	\$500, 000	Radio Frequency Drive Matrix	\$150, 000
Site Preparation	\$100, 000	Amplitude Control Matrix	\$ 50, 000
Total	\$1, 340, 800		\$1, 307, 000
Total for GMPTS	\$2, 647, 800		

* Production model is defined as one which is free of developmental engineering charges and for which there has been considerable prior learning production experience.

** Construction costs of the GMPTS at the site are contained in the above costs.

Table 3.3

radiating modules and the use of a microprocessor to supply proper dc voltages as position references for the operation of the motorized waveguide phase shifters in the feeds to the other three radiating modules in the subarray.

This suggestion for cost cutting is especially interesting for those applications where energy cost over the lifetime of the system is important. Under those conditions, the antenna becomes larger and the radiation density becomes much less, as given by equation (12) of Section 2.5.3. One microwave oven magnetron could then easily feed nine radiating modules, with the one in the middle being the only section with a phase comparator in it. In this case, the cost reduction in digital phase shifter, phase comparators, and digitized phase distribution network would be a factor of nine, while the interferometer and other fixed costs are reduced to a small portion of the total cost.

It was also the desire of the study to provide an estimate of the costs of constructing the first engineering model of the GMPTS within a relatively narrow cost range. But the reference design is neither mature enough nor detailed enough to use for this purpose. In this context the middle-range of detail in the conceptual design should be reiterated before any close cost estimating is attempted. And here it may be found that some of the cost cutting approaches need some experimental backup.

The cost of the first engineering model is also highly dependent upon how the development program is organized and carried out. It would appear that going directly to a full scale prototype would be more costly and certainly represent more risk than a staged program. In such a staged program, the first stage would be to develop the subarray prototype with major consideration being given to designing it for minimum production cost. The second stage would be to build a scaled-down version of the array and use either a beam riding helicopter or a tall overhead crane with appended instrumentation to check out the performance of the system. This could be an array with an area of from 100 to 200 square meters. Then the next stage would build a full scale GMPTS that is consistent with an LTA-HAPP vehicle whose power requirements could have been substantially modified because of being tailored to a particular operational site.

4.0 EXPERIMENTAL DATA FOR CRITICAL AREAS

In Section 1.0, it was indicated that a number of experiments were performed to provide facts to support assumptions in certain critical technological areas or to demonstrate the quantitative results of the application to the GMPTS of principles that had been established elsewhere.

These experiments had to do with experimental confirmation of the validity of a procedure used in the boresighting of the transmitting array and with external modifications of the conventional microwave oven magnetron to utilize it in the GMPTS.

4.1 Uniformity of Phase Over the Central Portion of a Single Radiation Module with Single Excitation

In Section 3.2.2.3, it was pointed out that the zero boresighting procedure was dependent upon the assumption that the phase remained constant over the central portion of a single radiating module when it alone was excited with microwave power at its input port. Although it is clearly evident that the slots radiate in phase with each other, it is not immediately clear that a region above the module can be found where the phase remains constant as a probe is moved up or down across the face of the radiating module at a fixed distance from the face.

An area where this favorable situation existed was found and data was taken and recorded. The experimental arrangement to obtain this data is described and then the recorded phase data is given in Table 4.1.

The test made use of the radiating module described in Section 2.4.1.3 and shown in Figure 2.6. The phase measuring probe was a commercial WR 430 waveguide to coaxial transition unit. The flanged face of the waveguide was mounted parallel to the face of the radiating module (Figure 2.6) at a distance of 25.4 cm. The flange was then moved first horizontally and then vertically from a centered position while maintaining the distances of 25.4 cm from the radiating module. During this movement, the phase of the pick-up by the waveguide probe was compared with the phase of the signal at the input port to the radiating module by means of the Hewlett Packard 8410B network analyzer.

Table 4. 1

Phase Variation with Lateral Position of Waveguide Probe

Horizontal Potion of Probe as Measured in λ's from Center	Phase Shift Degrees
- 1. 24	0
- 1. 04	+3
- 0. 83	+2
- 0. 62	0
- 0. 41	-1
- 0. 21	0
0. 0	0
+ 0. 21	0
+ 0. 41	0
+ 0. 62	0
+ 0. 83	+1
+ 1. 04	+6
+ 1. 24	+8

Vertical Position of Probe as Measured in λ's from Center	Phase Shift Degrees
- 0. 81	0
- 0. 58	0
- 0. 38	0
- 0. 23	-3
0. 0	0
+ 0. 21	+4
+ 0. 42	+3
+ 0. 62	0
+ 0. 85	+9
+ 1. 04	+15

**Data Showing Phase Variation as a Function of Lateral Position
of a Pick-Up Probe**

The data in Table 4.1 indicates that there was very little variation, only a few degrees, over a sizeable area considerably larger than a wavelength on each side. The small spread in the phase data is particularly interesting because some error is introduced in reading the network analyzer (0.5°), and in reading the horizontal separation variation ($\pm 1^\circ$).

In summary, the data indicates that calibrating the reference phase (equivalent to boresighting the antenna) at each radiating module is independent of the lateral position of the calibrator on the face of the radiating module as long as it is within a wavelength of the geometrical center of the module.

4.2 Adapting the Commercially Available Microwave Oven Magnetron to the GMPTS by Repackaging It

The commercially available microwave oven magnetron has three deficiencies for operation in the GMPTS that can be remedied by external modifications. These deficiencies are (1) it has no integral buck-boost coil, (2) it is under-coupled, and (3) it may not be precisely on 2.45 GHz frequency.

The first of these deficiencies requires an addition to the tube. The second and third deficiencies can be corrected by either external modification or by making internal changes to the tube. Although the internal changes are very simple, they would have to be made before the tube is sealed-in and pumped. Therefore, such tubes would be special tubes, and would cost more. It is possible, however, that since several thousands of tubes would be necessary, the additional premium for the tube would cost less than purchasing the standard tube and modifying it. The likelihood of this possibility becomes greater when considered in the context that adding the buck-boost coil requires negligible labor in an original assembly, while a standard tube would have to be disassembled and the coil added. Nevertheless, the option of reoperating an available shelf tube has been examined and found to be relatively straightforward.

4.2.1 Fitting the Commercially Available Magnetron with a Buck-Boost Coil

As shown in Figures 4.1 and 4.2, the mounting plate can be removed from a conventional microwave oven magnetron and a buck-boost coil can be slipped into a vacant space between the top ceramic magnet and the magnetic pole piece of the magnetron and the tube reassembled. The buck-boost coil then becomes a part of the closed magnetic circuit, and when excited with current, adds or subtracts to the permanent field created by the ceramic magnets. When the buck-boost coil is inserted into a properly designed feed back control circuit, it holds the power output of the tube nearly constant despite wide variations in the applied voltage to the tube, as shown in Figure 2.9, for example, and as described in Section 2.4.2.1.

The coil shown in Figures 4.1 and 4.2 was specially made for a preliminary evaluation of a modified tube for the GMPTS. Figure 4.3 is a plot of the magnetron operating voltage and power consumption of the buck-boost coil as a function of current in the coil. The data is experimentally obtained. The data indicates that the operating voltage of the magnetron and therefore the voltage of the dc power supply can vary over a range of 3330 to 3950 volts with a maximum power dissipation in the coil of eight watts. With a voltage range half of this, which would be consistent with the regulation provided by public utilities for such an operation, the maximum power consumption would be two watts. Coil power can be further reduced by using heavier wire, which would require a change in the packaging design to accommodate a larger coil.

The coil contained 200 turns of 0.038 cm diameter copper wire. Nominal resistance is 8 ohms and inductance with coil in place in circuit is 2.10 millihenries. The inductance is sufficiently low to assure very fast response time of the circuit with the high probability that it can be used to reduce the filtering requirement on the dc power supply.

ORIGINAL PAGE IS
OF POOR QUALITY

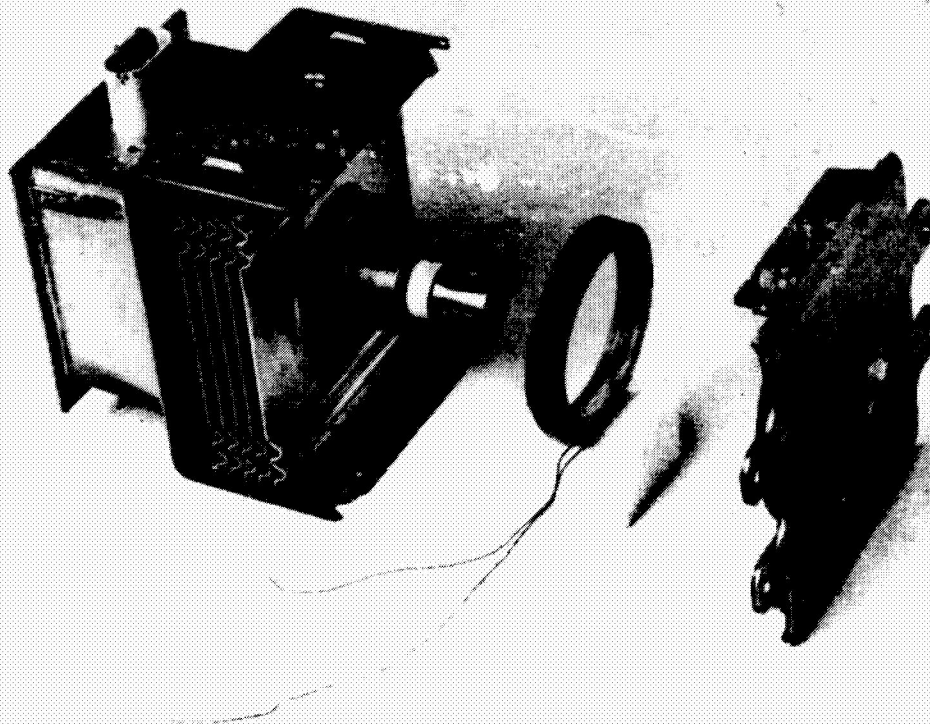

Figure 4.1 Exploded View of Microwave Oven Magnetron Fitted With a Buck-Boost Coil. Mounting Plate has been Removed from Magnetron Tube as It is Now Manufactured in order to Insert Buck-Boost Coil into the Tube's Magnetic Circuit. Buck-Boost Coil, as shown in Picture, is a Small Coil Consisting of 200 Turns of Copper Wire.

ORIGINAL PAGE 13
OF POOR QUALITY

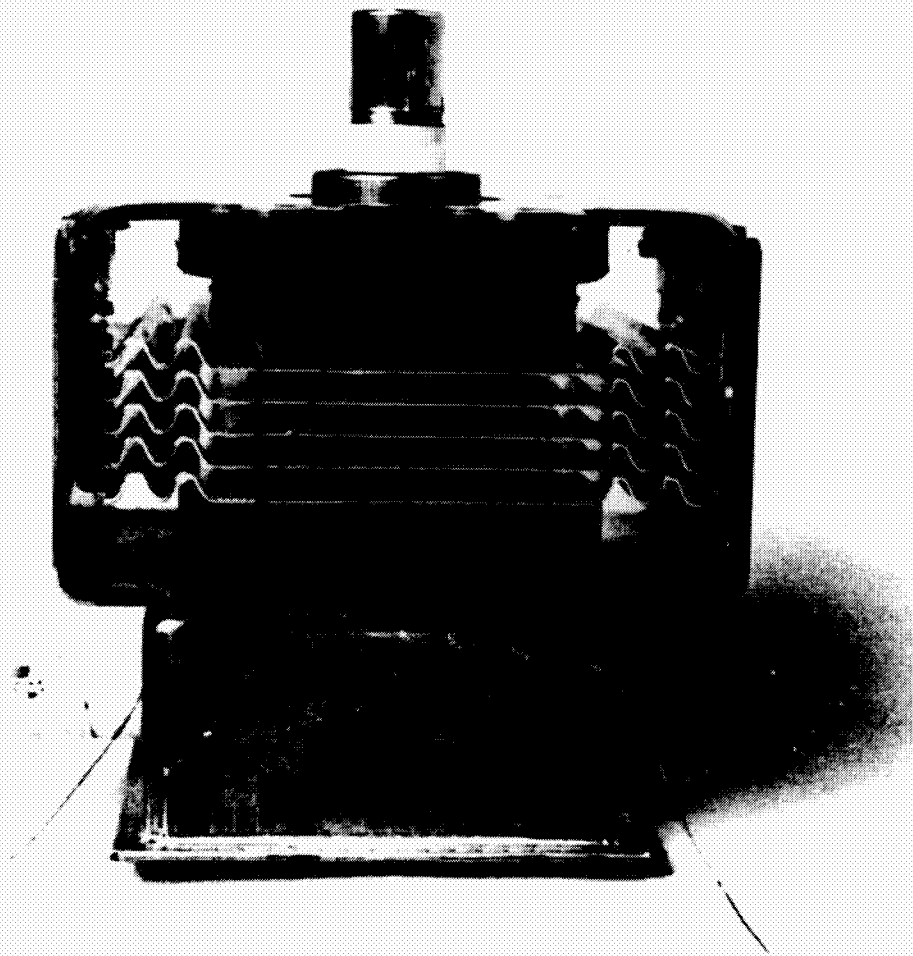

Figure 4.2 Reassembled Tube After Buck-Boost Coil Has Been Added

ORIGINAL PAGE IS
OF POOR QUALITY

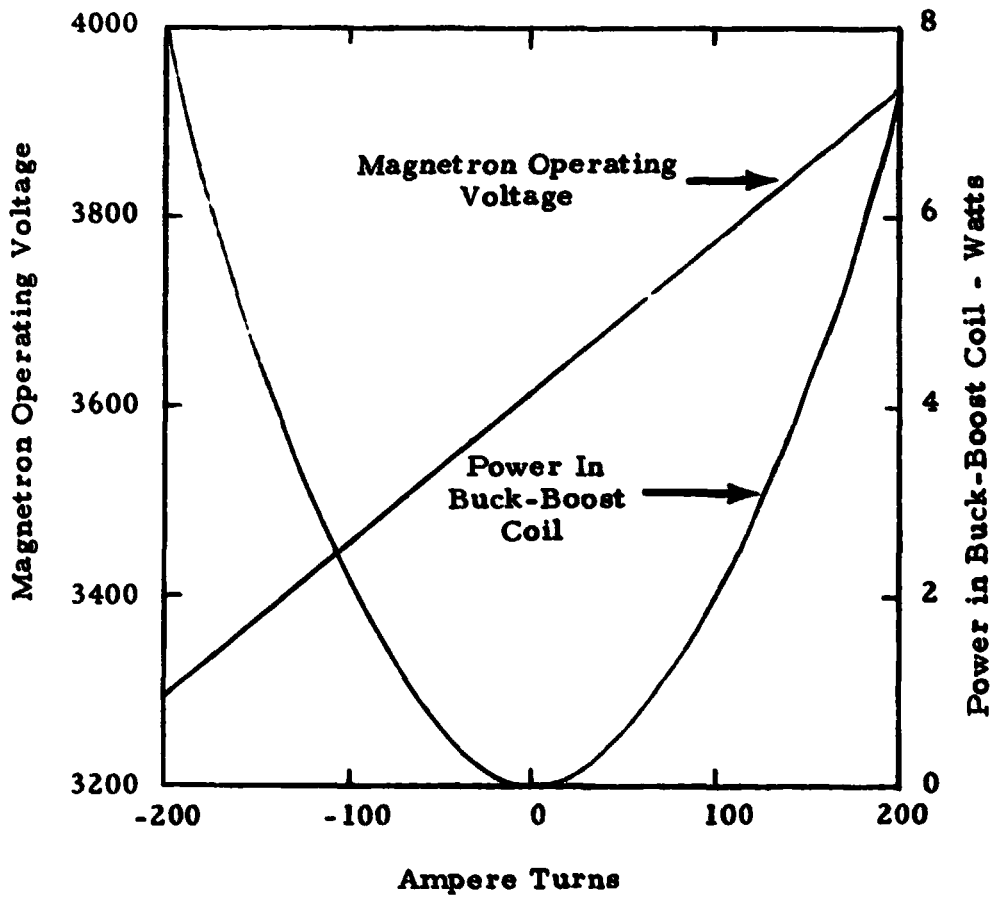

Figure 4.3 Experimental Data Indicating the Relationship Between Ampere Turns in the Buck-Boost Coil and the Operating Voltage of the Tube and the Power Required for the Buck-Boost Coil

4. 2. 2 Setting the Tube on Frequency and Increasing the Coupling

It is essential that the free running frequency of the magnetron be close to 2.45 GHz at the most probable operating point of the tube, where "operating point" is defined by a value of anode voltage and anode current. It is also desirable that the magnetron be coupled more tightly to the external circuit than it normally is in the microwave oven. This allows an external driving source to control the operating frequency of the magnetron over a much wider range of frequencies, and over a much wider range of environmental disturbances such as tube operating temperature. Fortunately, these two things can be done simultaneously by special circuitry between the tube and the point where the tube couples into the waveguide system.

In the experimental arrangement that was used, the output probe of the tube which normally couples directly into the waveguide, was coupled instead into a section of coaxial line which was terminated in a matched waterload so that power measurements as well as frequency measurements could be made. A moveable quarter wavelength transformer in the form of a cylindrical section of teflon was inserted between the inner and outer conductors of the coaxial line, and moved to the point that combines closer coupling and operation at 2.45 GHz. The coupling was increased by a factor of approximately 2.4.

This experiment demonstrated that the desired frequency centering and increased coupling could be brought about simultaneously under well controlled and understood conditions. A coaxial adaptor could be made to be inserted between the tube and the waveguide which must be used to accommodate the ferrite circulator. It is probable, however, that similar and desirable changes could be brought about by changing the geometrical arrangements in the coax to waveguide transition unit in which the magnetron antenna assumes the role of the coaxial probe. If this were found to be possible, it would almost certainly require that the transition unit itself become part of the magnetron package.

From a longer range viewpoint, it is believed that the magnetron directional amplifier should be an integrated structure that would consist of (1) an internally

modified magnetron that would couple tightly to the external load and that would be tuned to a preselected frequency that would correlate closely with an operating frequency of 2.45 GHz when it is tested as an operating tube, (2) a packaging of the magnetron that would include a buck-boost coil as part of the magnetic circuit, (3) an attached coax to waveguide transition unit that will have a screw-driver type of adjustment to put the tube precisely on frequency when it is being tested as a free running oscillator at the selected "operating point" of anode current and voltage, (4) a ferrite circulator which would consist of a small amount of ferrite and permanent magnet material incorporated into the waveguide, and (5) a probe attached to the waveguide for sampling the magnitude of rf power output and converting it into a dc voltage for feeding into one of the inputs of an operational amplifier. An additional option would be to mount the operational amplifier, which is essentially one solid state device, and any other portions of the amplitude feedback control loop on the package.

The following material is being inserted into this final report to provide the reader with information on a concept that came into being after the contract performance had been completed and after the drafting of the final report. In some respects the concept may be considered as a breakthrough in improving the performance of the GMPTS, and in simplifying it and reducing its cost.

The improvement came about as the result of looking at the application of the GMPTS as described in the final report to a microwave powered platform in the form of an airplane. It was observed that the mechanical phase shifters on the periphery of the antenna structure would have to operate rapidly to follow the circling airplane. Further, they would have to frequently and abruptly recycle, i. e., the phase-shifter would suddenly have to jump from $+180^{\circ}$ to -180° , or vice versa, depending on the flight direction of the airplane. This mode of operation is expecting too much from a mechanical phase shifter. While GMPTS design might be compatible with a balloon, particularly if it were not involved in circular flight, it is certainly a situation where a search for other approaches which would either eliminate the mechanical phase shifter or use it in a mode in which it would move only slowly and never have to abruptly recycle is desirable.

A considerable effort has gone into finding these approaches with the result that two technologies were found that could be of great help in solving the problem, and even in eliminating the mechanical phase shifters altogether. The first technology---and this is a new one, it is believed---is to convert the magnetron directional amplifier into a high-gain 30 dB amplifier with a phase-locked feedback loop form of operation. This makes it possible to drive the magnetron directional amplifier from a low level signal supplied by the phase reference and eliminate the present chain of magnetron directional amplifiers that originate at the center of the array. The second technology is that of the ferrite phase shifter which probably can be substituted for the mechanical phase shifter, perhaps up to 250 watts of power handling capability, but certainly much beyond what can be handled by a diode phase shifter and what has been considered before.

The phase locked mode of operation is achieved by using the error signal from the phase comparator at the output of the amplifier to change the current in the buck boost coil. The buck boost coil changes the operating current level of the magnetron in such a direction as to cause the free running frequency of the magnetron to match the driving frequency. Under these circumstances zero phase shift is achieved through the amplifier. The phase locking is achieved at the expense of some change in the power output level.

The phase locked high gain amplifier has the advantage that it preserves zero phase shift through the amplifier and therefore does not need an additional phase shifter at its input to compensate for phase shift which results from a change in operating characteristics of the tube or a change in line voltage. However, when the magnetron directional amplifier is operated in this mode, there is no control over the amplitude of the output during the operation of the system although there is some initial control over the amplitude by mechanical adjustment of the magnetron external load circuitry before it is inserted into the system.

To achieve freedom to vary the amplitude of the power radiated by the antenna, the high gain phase-locked amplifier may be used to drive another magnetron directional amplifier stage with both an amplitude and phase comparator in its output circuit. As well documented in the NASA Contractor Report 3383 "SPS Magnetron Tube Assessment Study," the output of the amplitude comparator is attached to the buck boost coil and the output of the phase comparator is now attached to a low level electronic phase shifter which is placed ahead of the input to the first magnetron directional amplifier. From the viewpoint of control system theory, the phase locked amplifier is just an internal control loop within a larger control loop.

The resulting two-stage amplifier now has the capability of a value of power output that ranges from the output of the first stage which would be in the range of 200 watts to an output limited only by the life of the filament of the microwave oven magnetron. In the case of the I.TA-HAPP, where high power is called for only infrequently, this could be two kilowatts. Now the subarray could consist of nine radiating modules with the phase reference identified with the central module.

The other modules would be satellite modules with power supplied them by the two-stage amplifier and with phasing programmed in an open loop manner from the logic element which is attached to the two-column digitized phase control matrix. Phasing control of the satellite radiating modules would be in the form of a voltage amplitude sent to an operational amplifier which is coupled in a position feedback control mode to a mechanical phase shifter or to a ferrite phase shifter. In the new format, the phase shifter, even on the periphery of the transmitting antenna, could operate within a $\pm 60^\circ$ phase shift with no recycling necessary. This relaxation of performance requirement is of great importance in reducing costs.

If this arrangement were used in the GMPTS, it would eliminate the present arrangement of three levels of directional amplifiers with its complication of waveguide transmission lines and directional couplers. Enough power would be put into the clock phase reference to act as a one watt (or less) drive to each subarray. The arrangement would also reduce the complexity of the row-column digitized phase control system by a factor of nine, and the number of digitally controlled phase shifters by the same factor. This simplification would be offset to some degree with the additional logic that would have to be built into each subarray to control the phase shift in the eight peripheral radiating modules in the subarray.