

TIME TRANSFER BETWEEN THE GODDARD OPTICAL RESEARCH FACILITY
AND THE U.S. NAVAL OBSERVATORY USING 100 PICOSECOND LASER PULSES*

C. O. Alley, J. D. Rayner, C. A. Steggerda, J. V. Mullendore, L. Small
and S. Wagner

Department of Physics and Astronomy
University of Maryland
College Park, Maryland 20742

ABSTRACT

A horizontal two-way time comparison link in air between the University of Maryland laser ranging and time transfer equipment at the Goddard Optical Research Facility (GORF) 1.2 m telescope and the Time Services Division of the U.S. Naval Observatory (USNO) has been established. Flat mirrors of 25 cm and 30 cm diameter respectively have been placed on top of the Washington Cathedral and on a water tower at the Beltsville Agricultural Research Center since direct line of sight transmission is not possible. The bent path has a one-way distance of 26 km. Two optical corner reflectors at the USNO, identical to those placed on the Moon during the Apollo program, reflect the laser pulses back to the GORF.

Light pulses of 100 ps duration and an energy of several hundred microjoules from a neodymium-YAG laser, frequency-doubled to a wavelength of 532 nm (green) are sent at a rate of 10 pulses per second. The detection at the USNO is by means of an RCA C30902E avalanche photodiode and the timing is accomplished by an HP 5370A computing counter and an HP 1000 computer with respect to a 10 pps pulse train from the Master Clock.

The reflected light is detected back at the 1.2 m telescope at the single photoelectron level and the epoch of reception is recorded by a University of Maryland designed event timer attached to a NOVA 2/10 minicomputer. About 100 detection events are recorded for 1000 pulses transmitted. The outgoing pulses have their epoch of transmission recorded by the same event timer, which is driven by an HP cesium beam frequency standard.

* This work has been supported by the U.S. Naval Observatory and the Office of Naval Research under contract N000 14-78-C-0338. The following members of the Time Services Division of the USNO have participated actively in the experiments: G.M.R. Winkler, W. Klepczynski, K. Putkovich, A. Kubik, P. Wheeler and D. Chalmers.

The Einstein prescription is used to relate the epoch of the received event at the USNO to the midpoint between the transmitted and received events at the GORF. This procedure is independent of the delays introduced by the atmosphere. The standard deviation for 100 comparisons is typically 200 to 400 ps. The corresponding standard deviation of the mean is 20 to 40 ps. We are still working on the calibration accuracy which at present is 1 to 2 ns, established by a portable clock trip.

The link was to have been a near real time connection with the USNO during our planned participation in the LASSO experiment. The link is also serving to provide experience for the high accuracy short pulse laser time transfer part of the Space Time and Frequency Transfer (STIFT) experiment to be discussed at this PTTI meeting.

INTRODUCTION

There have been two major purposes for the experiments described in this paper.

1) To gain additional practical experience with the short laser light pulse technique of time comparison between remote clocks. The method was pioneered in atomic clock experiments with aircraft which measured the effect of gravitational potential on time.¹ It will be used in both the Laser Synchronization from Stationary Orbit (LASSO)² and the Space Time and Frequency Transfer (STIFT)³ experiments, if these are carried out. The technique offers the most accurate practical means of remote time comparison.

2) To provide a link to the USNO from the GORF 1.2 meter telescope to facilitate time comparison with Western Europe during the LASSO experiment. The failure on 20 September 1982 of the third stage of the ARIANE rocket carrying the SIRIO-2 satellite with the LASSO instrumentation has prevented this experiment from being performed. The LASSO participants have been informed by P. Berlin, the project manager for the SIRIO-2 satellite, and B.

¹ C. O. Alley, "Relativity and Clocks", Proceedings of the 33rd Annual Symposium on Frequency Control, U.S. Army Electronic Research and Development Command, Fort Monmouth, NJ, pp. 4-39A (1979). Copies available from Electronic Industries Association, 2001 Eye Street, N. W. Washington, D. C. 20006.

² B.E.H. Serene, "Progress of the LASSO Experiment," Proceedings of the Twelfth Annual Precise Time and Time Interval (PTTI) Applications and Planning Meeting; NASA Conference Publication 2175. pp 307-327, December 2-4, 1980.

³ R. Decher, D.W. Allan, C.O. Alley, C. Baugher, B.J. Duncan, R.F.C. Vessot, and G.M.R. Winkler, "High-Accuracy Global Time and Frequency Transfer with a Space-Borne Hydrogen Maser Clock", Proceedings of the Fourteenth Annual Precise Time and Time Interval (PTTI) Applications and Planning Meeting, November 30 - December 2, 1982. To be published as a NASA Conference Publication.

Serene, the project manager for LASSO, that there is active consideration now being given within the European Space Agency to flying a new SIRIO-2B satellite with LASSO instrumentation, using existing engineering test equipment. If the decision is favorable, and another ARIANE launch can be arranged, perhaps the LASSO experiment can be performed in about two years.

THE SHORT LIGHT PULSE TIME TRANSFER TECHNIQUE

Einstein's Prescription

The idea of using short light pulses to compare the readings of separated clocks is one of the conceptual foundations of relativity contained in Einstein's original paper.⁴ It is remarkable that the advent of lasers with their ability to produce very short pulses of light has allowed the method to be implemented as perhaps the most accurate means of remote time comparison.

The method is illustrated in the spacetime diagram of Figure 1. In an inertial system in the absence of an atmosphere, the speed of light is

$$c \approx 2.9979 \times 10^8 \text{ m/s} \approx 30 \text{ cm/ns}, \quad (1)$$

so that for the units shown, the light lines have a slope of 45° for an outgoing pulse and -45° for an incoming pulse, representing the same velocity in each direction.* If a pulse is sent out at time t_1 , reflected from a distant point at time t , and received back at time t_3 , then t_2 , the midpoint in time between t_1 and t_3 , is to be identified with t , according to Einstein:

$$t_2 = t_1 + (t_3 - t_1)/2 = (t_1 + t_3)/2 = t. \quad (2)$$

Also, the distance x is given by the radar equation from the difference between measured epochs t_1 and t_3 :

$$x = (t_3 - t_1) c/2. \quad (3)$$

The effect of the atmosphere is to reduce the speed of light from c to c/n , where n is the index of refraction. (The detailed physics leading to this result is rather complex and not widely known, but will not be discussed here.) The value of n depends on the frequency of the light, the atmospheric pressure, the temperature, and the composition of the atmosphere, including

⁴ A. Einstein, "Zur Elektrodynamik Bewegter Körper," *Annalen der Physik*, 17, 1905. A translation into English is available: "On the Electrodynamics of Moving Bodies," in The Principle of Relativity, a Collection of Original Papers on the Special and General Theory of Relativity, translated by W. Perrett and G. B. Jefferey, Dover Publications, Inc., New York, 1952.

* In a coordinate system attached to the surface of our rotating Earth, which is not an inertial system, the speed in the East-West direction differs from that in the West-East direction by about 3×10^{-6} at the equator. In the present experiment, the effect might be barely detectable as the calibration is refined.

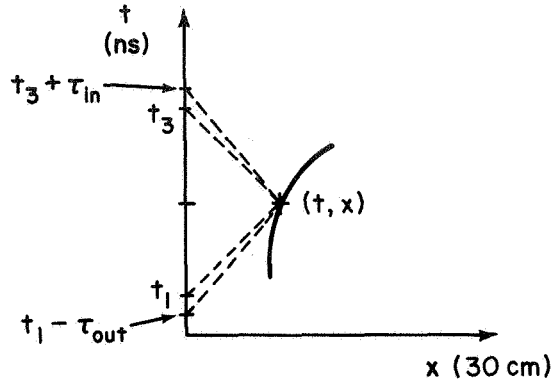

Fig. 1. The Einstein Prescription.

the partial pressure of water vapor. (The dependence on water vapor is far smaller for optical frequencies than for microwave and radio frequencies.) The atmosphere thus produces an additional time delay for the light pulse on the way out, τ_{out} , and a corresponding delay on the way in, τ_{in} , as shown in Figure 1. The Einstein prescriptions for determining the coordinates (t, x) of the reflection event as expressed in equations (2) and (3) now become

$$t = [(t_1 - \tau_{out}) + (t_3 + \tau_{in})] / 2 = (t_1 + t_3) / 2 + (\tau_{in} - \tau_{out}) / 2 \quad (4)$$

nearly cancel

$$x = [(t_3 + \tau_{in}) - (t_1 - \tau_{out}) - (\tau_{in} + \tau_{out})] c / 2 \quad (5)$$

measured round trip time additive

Note that for the time determination in equation (4), the atmospheric delays, τ_{out} and τ_{in} , occur as a difference. They are essentially the same and will nearly cancel. The Einstein prescription for determining the time of a distant event by the midpoint in time between the emitted and the received (reflected) pulse is essentially unaffected by the atmosphere.

This is to be contrasted with the effect of the atmosphere on the distance determination, equation (5), in which the sum of the delays τ_{out} and τ_{in} must be subtracted. An accurate distance measurement requires that the atmospheric delays be known.

An added advantage of the light pulse method of determining the time of a distant clock with respect to a local clock is that the motion of the distant clock does not have to be considered in the comparison between the local midpoint event and the distant reflection event. There are no Doppler effect complications.

However, if the distance between the clocks is not changing, one can use the radar delay to determine the one-way time difference. This is helpful when the returned light pulse is so weak that single photo-electron detection

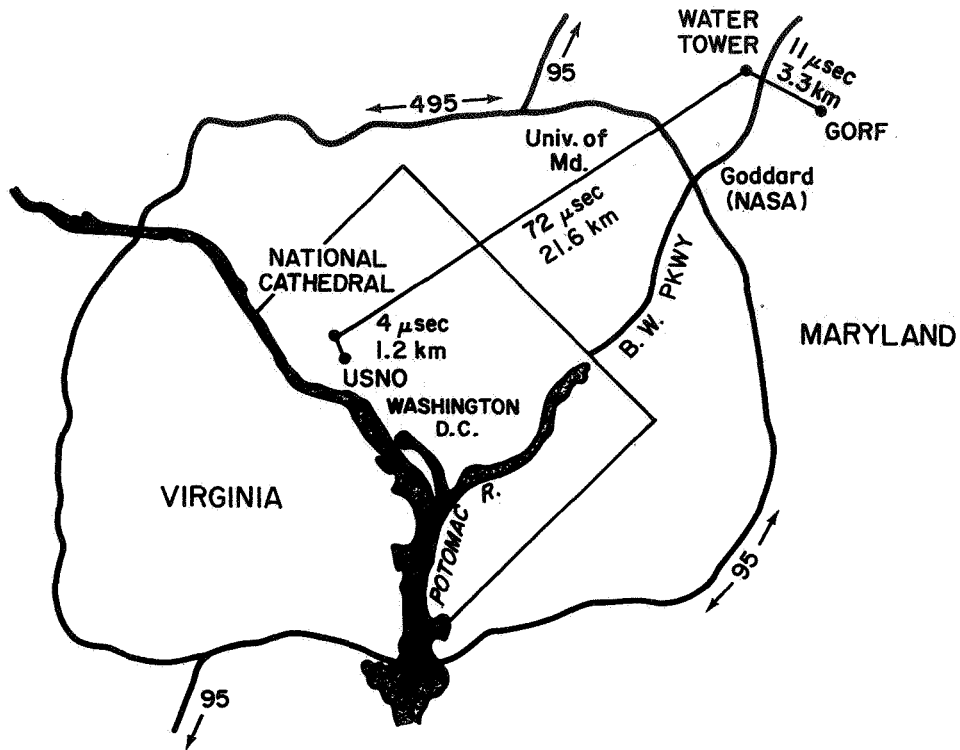

Fig. 2. The path of the laser beam across Washington.

is required. Under these circumstances the reflected pulse at t_3 will not be recorded for each shot, but only with a certain probability, perhaps one in ten. This will be discussed in the later section on the analysis of typical data.

Path Across Washington and Atmospheric Effects

The actual path of the light pulses from the 1.2 m telescope at the Goddard Optical Research Facility to the dome on the roof of the Time Services Building at the U.S. Naval Observatory where two lunar type corner reflectors and a detector are located is shown in Figure 2. A direct line of sight is not possible because of the topography of the Washington area, but a 30 cm flat mirror on a water tower at the Beltsville Agricultural Research Center and a 25 cm flat mirror on the top of the National Cathedral (the highest point in the Washington area) allow a connection. The approximate light travel times and distances for the several legs are given on the map. The total one-way light travel time is 87 microseconds corresponding to a total one-way distance of 26 km. The value of the atmospheric index of refraction⁵ for green light of 532 nm wavelength from the frequency-doubled neodymium YAG

⁵ C.W. Allen, Astrophysical Quantities, the University of London Athlone Press, London, Second Edition, 1955, pp 119f. This reference contains many useful tables and formulas for the optical index of refraction.

laser, for a pressure of 760 mm of Hg, for a temperature of 15° C, and for water vapor pressure of 4 mm of Hg is given by

$$n - 1 = 0.000277 \quad (6)$$

and produces a one-way atmospheric delay of 24 nanoseconds. This does not matter for the Einstein prescription, as discussed above. Other atmospheric effects do cause experimental troubles, however.

If the "visibility" as quoted for the Washington National Airport is less than five or six miles, we cannot detect reflected light over the 52 km round-trip path even at the single photo-electron detection sensitivity for our several hundred microjoule pulses of green light.

Instabilities in the atmosphere associated with a changing vertical temperature gradient, which often occur a cloudless cold night after a warm day, require frequent adjustment of the pointing of the 1.2 m telescope to keep the narrow laser beam on the water tower mirror. This bending of the light is similar to mirage effects. The laser beam is about 2 cm in diameter as it leaves the telescope, expanding to about 45 cm over the 3.3 km path to the water tower. At the cathedral the beam is 200 to 300 cm wide and scintillations are observed - a changing mottled pattern - caused by the non-uniformity of the atmosphere in the transverse dimension of the beam during the 21.6 km path to the cathedral. Changing vertical temperature gradients also require occasional angular adjustment of the water tower mirror to keep the beam on the cathedral mirror. At the USNO the laser beam has a horizontal extent of about 15 cm and a vertical extent of about 25 cm, the projected dimensions of the cathedral mirror as it intercepts the beam.

Methods of Aligning the Mirrors

It has proven necessary during a time transfer to have people at the various locations to make the initial mirror alignments and to maintain them: one person at the USNO, one person at the cathedral, and two persons at the water tower. Three persons are needed at the telescope to operate it, the laser, and the computer, and to coordinate all the activities. A telephone has been installed at each location and a conference call is arranged during each time transfer exercise to allow the necessary communications.

The most difficult adjustment is the initial alignment of the water tower and cathedral mirrors. A very elegant and fast method of accomplishing this was finally devised by D. G. Currie, J. V. Mullendore, C. A. Steggerda, and C. O. Alley, at the University of Maryland. The idea derives from methods used to direct narrow laser beams to a specific location on the Moon.⁶ The method uses a high quality 38 mm diameter circular corner reflector identical to

⁶ C.O. Alley, "Laser Ranging to Retro-Reflectors on the Moon as a Test of Theories of Gravity," in Quantum Optics, Experimental Gravitation, and Measurement Theory, edited by P. Meystre and M.O. Scully, Plenum Publishing Corporation, New York (1983).

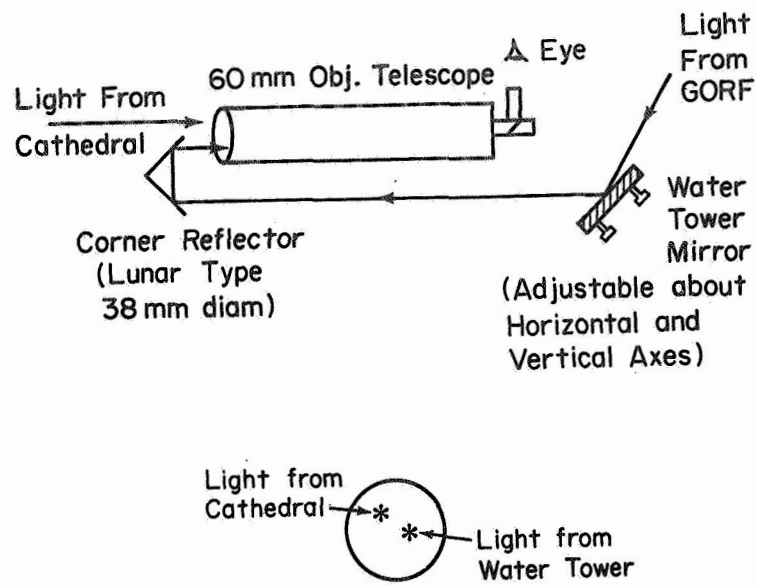

Fig. 3. Optical arrangement for the telescope which looks forward and backward at the same time.

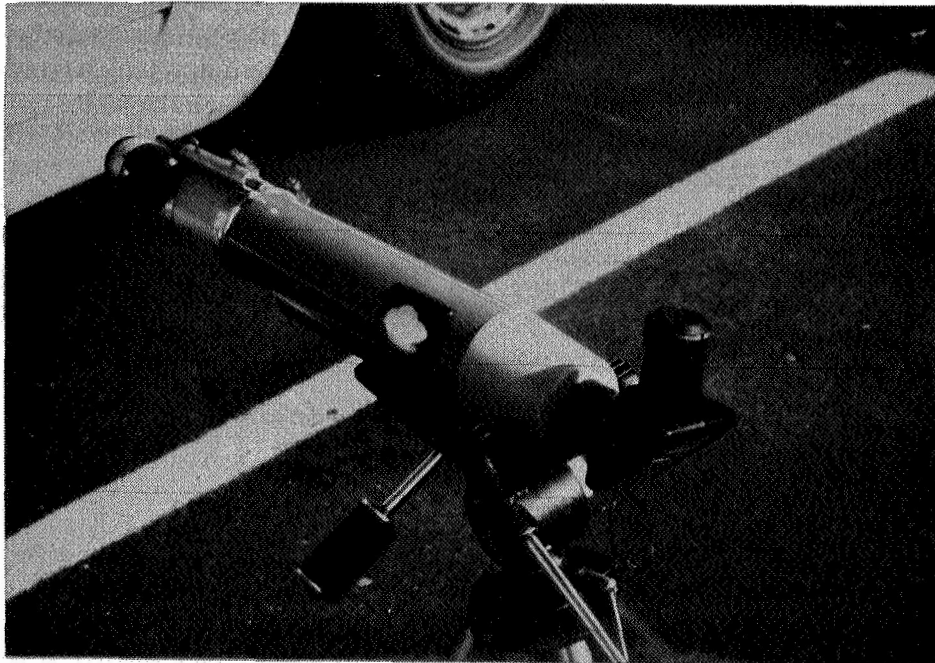

Fig. 4. Picture of the forward and backward looking telescope.

those placed on the Moon, together with an Edmund Scientific Company Celestial/Terrestrial 60 mm objective refracting telescope. Figure 3 shows the arrangement. It allows one to look forward and backward at the same time. A corner reflector has the property that an entering ray of light is reflected three times at three orthogonal mirrors, emerging at a diametrically opposed point with a reversed propagation vector. When the reflector is mounted as shown, halfway across the entrance pupil of the telescope, the view from behind is superposed on the normal field of view of the telescope. Coarse adjustment of the mirror is achieved by viewing the cathedral and the GORF telescope dome during daylight, bringing the telescope dome into coincidence with the corner of the cathedral spire. Fine adjustment is done at night by superposing the image of the attenuated laser beam on the image of an incandescent light placed at the cathedral mirror. Once this is done, the laser beam is guaranteed to hit the cathedral mirror. An even finer angular adjustment can now be accomplished by temporarily placing a corner reflector at the cathedral mirror and observing the reflection from it in the 60 mm telescope (after rotating its corner reflector out of the way) adjusting the water tower mirror to maximize the intensity. A picture of the forward and backward looking telescope is shown as Figure 4.

For the water tower mirror, this procedure with the two-way telescope and lights must be done before each time transfer exercise since the alignment does not stay constant. We believe that both the changing water level in the tank and the temperature changes in the structure cause the angular changes in the mirror. Carrying the equipment to the top of the tower, setting it up, and making the adjustments usually requires about a half-hour. For the cathedral mirror, the two-way telescope is used only rarely since the mounting of the mirror is very stable, and the optical "lever arm" to the USNO is only 1.2 km. Usually, an adjustment of only 30 to 60 cm in translation is needed. This is accomplished by observing the position of the green light from the laser on the back of the dome, and adjusting the cathedral mirror until the detector/reflector combination casts a shadow in the middle of the green spot. The propagation vector reversal of the corner reflectors adjacent to the detector at the USNO causes the reflected light to retrace the path back to the telescope at the GORF.

DESCRIPTION OF THE EQUIPMENT

Laser and Timing Instrumentation at the GORF

At the 1.2 m telescope a frequency doubled neodymium YAG laser produces 100 picosecond duration pulses of green light at 532 nm, each with an energy of about 0.5 millijoule. For the time transfer experiments the repetition rate is set at 10 pps to match the 10 pps master clock pulse train at the USNO, although the laser is capable of operating at 30 pps. This laser is described in detail in a recent paper⁷ and is the same one that was used in

⁷ C. O. Alley, "Proper Time Experiments in Gravitational Fields with Atomic Clocks, Aircraft, and Laser Light Pulses." in Quantum Optics, Experimental Gravitation, and Measurement Theory, edited by P. Meystre and M. O. Scully, Plenum Publishing Corporation, New York (1983).

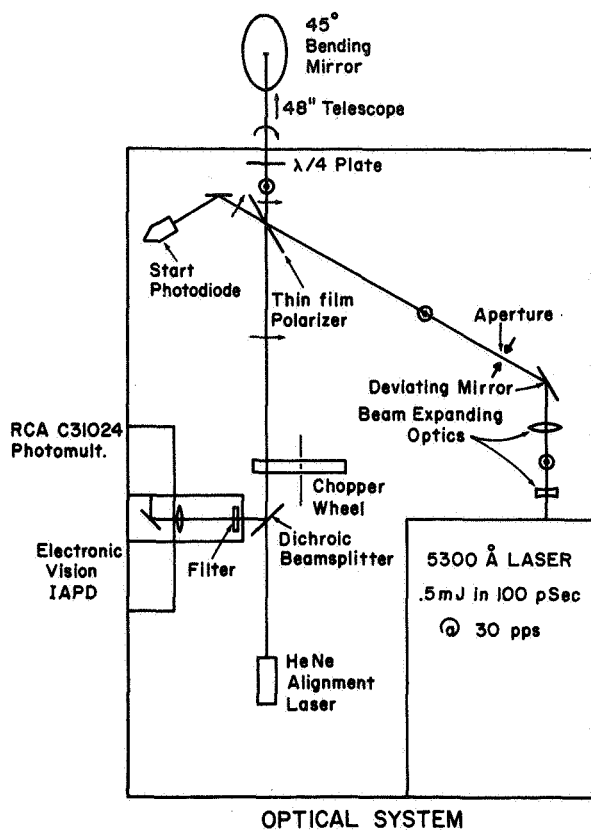

Fig. 5. Coupling of laser and detector to the telescope.

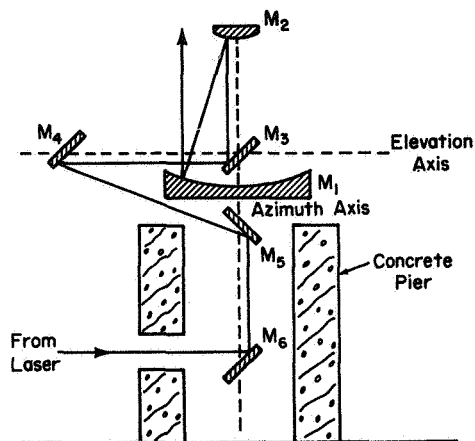

Fig. 6. Path of the laser beam through the telescope.

the aircraft atomic clock relativity experiments (reference 1). The optical system for coupling the laser to the telescope and for detecting the reflected light is shown in Figure 5. The pulse from the laser is linearly polarized with the electric vector vertical. It therefore reflects from the multi-layer thin film polarizer and passes through a quarter-wave plate which converts the linear polarization to circular polarization. The pulse is reflected off-center from a 45° bending mirror (M_6 in Figure 6), allowing it to proceed through the telescope optics as shown in Figure 6, emerging with a diameter of about 2 cm from the annular region between the edge of the primary mirror M_1 and the edge of the secondary mirror M_2 .

The returning light has suffered some depolarization, but is still mainly circularly polarized in the opposite sense. On passing through the quarter-wave plate the light becomes linearly polarized in the horizontal plane and therefore passes through the thin film polarizer. A rotating chopper wheel carries a vane which blocks the light which has been scattered back from the telescope optics and nearby atmosphere. The chopper wheel is phased to be open when the return light appears after the 174 micro-second round trip time. The light is reflected from a dichroic beam splitter through a 10 Å spectral filter and through neutral density filters (variable from zero

attenuation up to N.D. 12). The return light is then focussed to a small spot on the photocathode of an RCA 31024 photomultiplier tube. The neutral density filters allow the simulation of the single photo-electron detection which will be needed in the LASSO experiment (the satellite will be in synchronous orbit). They also allow the equipment to be checked at the single photoelectron level by ranging to a corner reflector located on the water tower. An excellent review article by S. K. Poultney gives many details on the techniques of accurate time measurements with single photoelectrons.⁸

The electronic timing equipment is shown in the block diagram of Figure 7. The start pulse is obtained from a fast photodiode responding to leakage light from the multilayer thin film polarizer. A standard NIM pulse is formed by an Ortec discriminator and passes through an 'or' circuit and a clean up discriminator to an event timer/computer combination which records the epoch of the outgoing pulse with a resolution of 50 ps. The single photoelectron pulse from the photomultiplier is amplified by two Hewlett-Packard wide band amplifiers and goes to an Ortec 473 constant fraction discriminator which minimizes the "walk" in time associated with amplitude fluctuations. A range gate is provided by an adjustable width pulse activated by an "alarm clock pulse" from the event timer/computer combination. The E G & G fast trigger is open only when activated by the adjustable width pulse. The return pulse then passes through the same 'or' circuit as the start pulse and on to the event timer where its epoch is recorded in the NOVA 2/10 computer. The equipment above the dashed line is located in the telescope dome and that below the dashed line is in a trailer adjacent to the dome.

The event timer is basically a clock which can be read with a resolution of 50 ps without stopping it. It can handle up to 100 pulses per second, a limit currently imposed by the associated computer. The operation of the event timer is illustrated schematically in Figure 8. A 5 MHz external reference frequency (currently an HP 5061 cesium standard; for the LASSO experiment a hydrogen maser was to have been used) is doubled to 10 MHz inside the event timer and operates a synchronous counter. An incoming NIM pulse latches the synchronous counter to provide the epoch to 100 ns. The 0.05 ns resolution is achieved by a dual slope integrator in which the pulse also starts a capacitor charging until it is stopped by an appropriate pulse in the 10 MHz train. The capacitor is then discharged in a time 250 times longer than the charging time, and the discharge time is measured with an 80 MHz oscillator to the nearest cycle. Details of the basic circuits are given in a University of Maryland Technical Report.⁹ (A new type of event timer is being developed at the University of Maryland by C.A. Steggerda with a resolution of 10 to 20 ps.)

⁸ S. K. Poultney, "Single Photon Detection and Timing: Experiments and Techniques," in Advances in Electronics and Electron Physics, vol. 31, edited by L. Marton. Academic Press, New York and London (1972).

⁹ C.A. Steggerda, "A Precision Event Timer for Lunar Ranging," University of Maryland Technical Report 74-038, November, 1973.

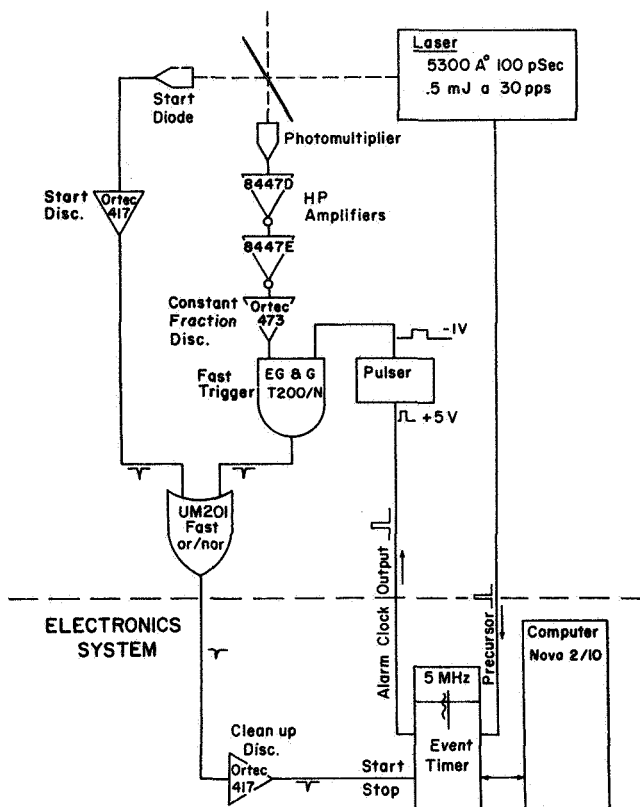

Fig. 7. Electronic timing equipment at the 1.2 m telescope.

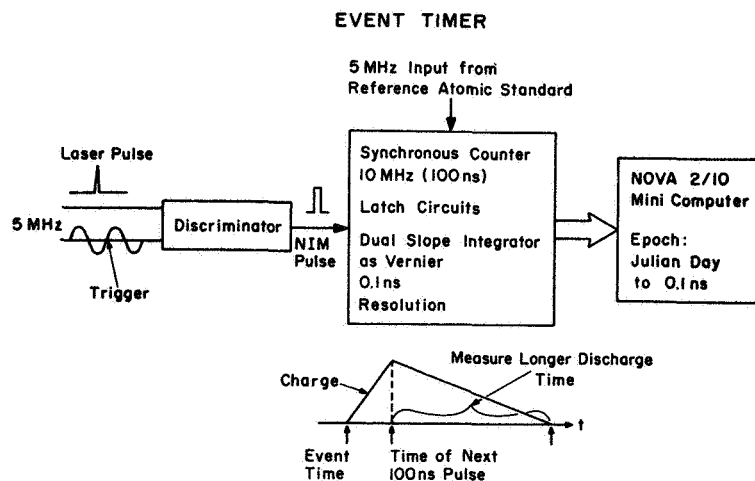

Fig. 8. Operation of the event timer.

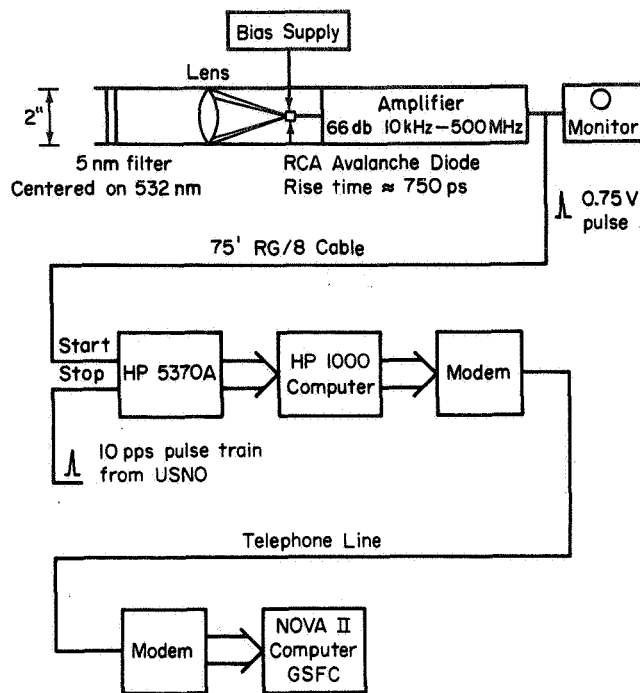

Fig. 9. Instrumentation at the USNO.

Instrumentation at the USNO

Figure 9 is a block diagram of the equipment installed at the Time Services Division of the USNO. The detector is an RCA C30902E silicon avalanche photodiode of the same type used in the LASSO instrumentation (reference 2). It has a rise time of 500 ps. We chose it rather than a faster detector in order to gain experience with the expected performance of the LASSO equipment. A 5 nm band pass spectral filter precedes a 2-inch diameter lens which focusses light on the diode. Provision is made for adding neutral density filters. The fluctuations in amplitude of the laser pulses reaching the detector are quite large due to scintillation effects in the 26 km air path across Washington. (It is interesting to note that in transmitting to space, the vertical scale height of the atmosphere is only 7 km). The wide band amplifier, similar to that in the LASSO equipment, produces a rise time of about 750 ps, and drives a typical 0.75 v pulse down 75 feet of low loss RG/8 cable to start a HP 5370A computing counter. The stop pulse for the counter comes from the 10 pps train of the USNO Master Clock. The measured arrival time of each laser produced pulse at the counter with respect to the Master Clock can be stored in an HP 1000 computer. This computer can be accessed by telephone connection from the NOVA computer at the GORF site and instructed to create a data file which is then transferred from the USNO. These are the times "t" to be compared with the times "t₁" and "t₃" defined above in the description of the Einstein Prescription. This analysis is done by the computer at the GORF site.

ANALYSIS OF TYPICAL DATA

The expected return from the LASSO retro-reflectors on the SIRIO-2 satellite in synchronous orbit was at the single photo-electron level. That is, not every firing of the laser would produce a detected return event, and one must treat the returns in a statistical way, there being only a probability of detection for each shot. To simulate this condition we are able to add neutral density filters in front of the photo-multiplier. This is necessary only when the visibility is very good -- on the order of 15 to 20 miles. For poorer visibility the single photoelectron detection must be used with zero attenuation. We try to simulate the LASSO return with a probability of about one detection in ten shots.

Under these conditions it is convenient to take advantage of the constant distance for the horizontal timing link. (The distance to a synchronous satellite is also approximately constant for short times; for longer times one could fit a smooth curve to the measured range). We measure first the two-way time delay (range) in a statistical way. Then one half of this value is taken as the one-way time delay and used to identify "matches" between the epoch t_1 of the sending event and the epoch t of the pulse arrival at the USNO. This allows a determination of the time difference between the clock at the GORF and the Master Clock at the USNO. A typical time transfer is carried out with 1000 transmitted pulses, requiring 100 seconds at the 10 pps firing rate. Midway into the run, the HP1000 computer is instructed to record epochs of arrival of pulses at the USNO for the next 100 transmitted pulses and to transmit these back to the NOVA computer, creating a data file. (Because of scintillations at the USNO detector, a few of the pulses are not detected.)

Some analyzed results from time transfers carried out 14 minutes apart during the evening of 2 July 1982 are shown in Figures 10 and 11 (draftsman's copies of the display on the Tektronix graphics terminal attached to the NOVA 2/10 computer). The top histogram in each figure shows the distribution of the round trip time measurements. In our earlier notation, the measured quantity is

$$(t_3 + \tau_{in}) - (t_1 - \tau_{out}).$$

The bottom histogram in each figure shows the distribution of the measured time difference between the USNO and the GORF. In our earlier notation, the measured quantity is

$$t - [(t_1 - \tau_{out}) + \langle (t_3 + \tau_{in}) - (t_1 - \tau_{out}) \rangle_{AV}].$$

For each of the time transfers, an attenuation of the returned signal by N.D. 3.5 (approximately 3×10^3) was imposed to obtain single photoelectron detection.

For the earlier time comparison of Figure 10, 55 returns were recorded out of 1000 shots yielding a measured round trip time of 174.3291 μ s with a standard deviation of 690 ps. The spread in the distribution is caused primarily by the jitter in the transit time in the photomultiplier detector

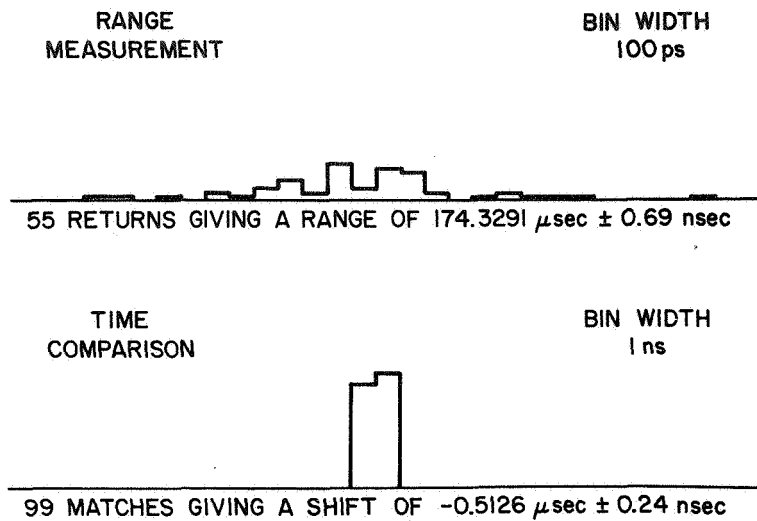

Fig. 10. Time Transfer on 2 July 1982 at 04:32 UTC.

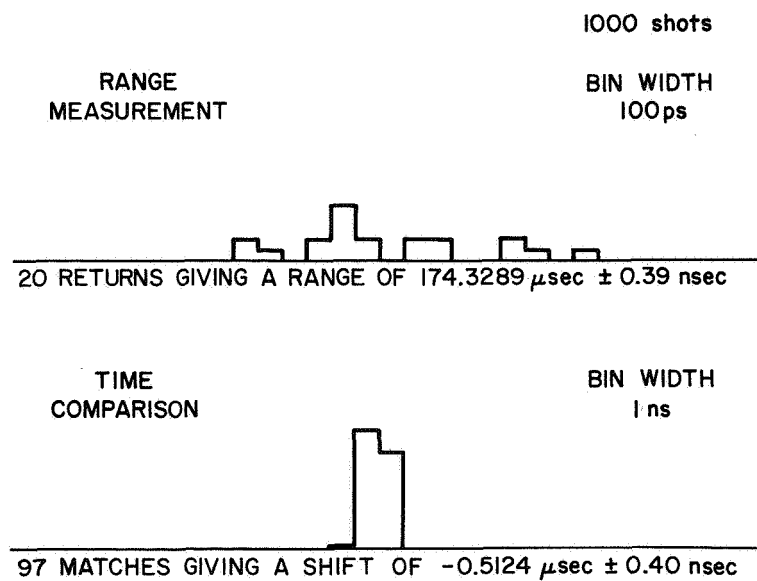

Fig. 11. Time Transfer on 2 July 1982 at 04:46 UTC.

operating at the single photoelectron level. The spread in the distribution of time comparisons is somewhat tighter since no single photoelectron detection is involved. For 99 matches, the standard deviation is 240 ps about a mean time difference of -512.6 ns.

For the later time transfer, shown in Figure 11, atmospheric conditions had deteriorated somewhat and only 20 returns were detected out of 1000 shots. The measured round trip time was 174.3289 μ s with a standard deviation of 390 ps. There were 97 time comparisons, giving a mean time difference of -512.4 ns with a standard deviation of 400 ps. The two measurements are consistent.

The standard deviations of the mean for the two time comparisons are 24 ps and 41 ps respectively. Most of the spread in the distributions is thought to be caused by the detector electronics at the USNO as influenced by the scintillation induced intensity fluctuations in the light pulses. We intend to install a faster detector and circuits whose delay is less sensitive to amplitude changes. Also in the future, we intend to replace the photomultiplier detector with another photomultiplier having faster response, less jitter, and higher quantum efficiency.

If the Einstein prescription for time comparison were used directly with the above data, only 55 comparisons in the first run and 20 in the second run would be possible. This would not matter if the measured distributions had very small dispersions, but with the present detectors the incorporation of the measured round trip time is desirable. In addition, use of the Einstein prescription would have required that the arrival times at the USNO be recorded for each of the 1000 transmitted pulses and sent back to the GORF instead of recording and sending back the 100 pulses in the middle of the sequence.

Calibration of the laser timing link has been accomplished so far only by a clock trip of about 30 minutes duration between the USNO and the GORF. The portable clock was compared directly with the USNO Master Clock at the HP5370A computing counter and by means of the event timer at the GORF with the HP cesium beam clock at that site. These are the basic reference points for the time comparison. The stability of the clock during the trip, estimated at 1 to 2 ns, gives the level of calibration. We plan to make measurements of the actual delays between the optical detectors and the basic reference points. It is hoped that these delays can be determined to 0.1 ns. The laser pulse link alone could then establish synchronization at this level which would require allowance for the East-West asymmetry in the speed of light mentioned earlier as a footnote to the discussion of the Einstein prescription for time comparison.

PHOTOGRAPHS OF THE EQUIPMENT

The details of experimental equipment are often best shown by actual photographs, which also convey impressions not achievable with words and drawings. The following series of pictures traces the path of a photon participating in the light pulse time transfer as the photon itself might

see it.

Figure 12 is a cutaway artist's drawing of the 48-inch (1.2 m) precision tracking telescope at the GORF.* The optical path through the telescope shown in Figure 6 can be better understood by comparing it with Figure 12. The computer controls for directing the telescope are in the room to the left. Our event timer and related equipment are located in a trailer parked adjacent to the dome on the right.

Figure 13 shows the Newport Research optical table on which the equipment of Figure 5 is located. The electronic equipment of Figure 7 is in the rack under the table. The enclosure on top of the table contains filtered air to protect the optics.

Figure 14 shows the water tower on the horizon 3.3 km from the telescope as seen through the dome opening.

Figure 15 is a picture of the water tower. The 30 cm mirror mount can be seen on the left inside the catwalk. The ladder for climbing the tower is hidden by the trees.

Figure 16 is a view of the water tower mirror mount with the front removed from the aluminum box which protects the mirror from the weather. The finely adjustable mirror mount was made by Aerotech. The micrometers for rotating about the horizontal and vertical axes can be seen at the bottom of the mount.

Figure 17 is a picture of the National Cathedral as seen on the horizon from the water tower. Because the cathedral is on a hill, the top of its tower is slightly higher than the Washington Monument.

Figure 18 is a picture of the cathedral tower taken from the ground showing the parapets between which the laser pulses enter and leave. The mirror mount cannot be seen from the ground.

Figure 19 shows the mirror mount on top of the brick stairwell enclosure. This is a very solid structure containing a spiral staircase. The adjustable mount for the mirror is identical to the one on the water tower but houses a 25 cm (10 inch) flat mirror. The reason for the difference in sizes is that these mirrors were available from the beam directing optics used in the aircraft relativity experiments with atomic clocks performed in 1975 and 1976, described in references 1 and 7, and also at the last PTTI meeting.¹⁰

* We are very grateful to Michael Fitzmaurice, John Degnan, and others of the Optical Instrumentation Branch of the Goddard Space Flight Center for kindly allowing us to use this excellent facility.

¹⁰ C.O. Alley, "Introduction to Some Fundamental Concepts of General Relativity and to Their Required Use in Some Modern Timekeeping Systems," Proceedings of the Thirteenth Annual Precise Time and Time Interval (PTTI) Applications and Planning Meeting; NASA Conference Publication 2220, pp. 687 - 724, December 1 - 3, 1981.

Figure 20 shows the domes of the USNO framed between parapets with the Kennedy Center and Potomac River in the background. The small dome in the center is on top of the Time Services Building and contains the detector and corner reflectors. Spectacular views of Washington are seen from the top of the cathedral.

Figure 21 shows the dome on the roof of the Time Serves building. The detector/reflector combination is mounted on an unused telescope mount in the center, as seen in Figure 22. The detector/amplifier assembly shown in Figure 9 is in the cylinder at the top left. The two corner reflectors are at the top right. They are the same ones used in the aircraft time transfer experiments described in references 1, 7 and 9 and are mounted in the housings constructed for the outside of the aircraft. The lower panel of reflectors was lent by the Marshall Space Flight Center as part of the studies for the STIFT experiment. It is not presently used.

Figure 23 shows the top of the cathedral above the trees as seen from the roof of the Time Services Building. The green laser flashes come from between two smaller parapets at the right.

Figure 24 looks toward the water tower from the top of the cathedral. Since the water tower does not project above the horizon it is not distinguishable at its distance of 21.6 km in this daytime photograph. However at night, when the laser beam is correctly pointed, the green flashes are by far the brightest light in the whole Washington area.

The final picture in the series, Figure 25, is a reflection in the water tower mirror of the many domes at the Goddard Optical Research Facility. The large dome on the right, just to the left of the dome on a tower, contains the telescope where the trip began, which is also the final destination for the photon.



Fig. 12. Transmit/Receive telescope at the GORF.



Fig. 13. Optical and electronic equipment for transmitting and receiving laser pulses.



Fig. 14. Water tower seen from the telescope.

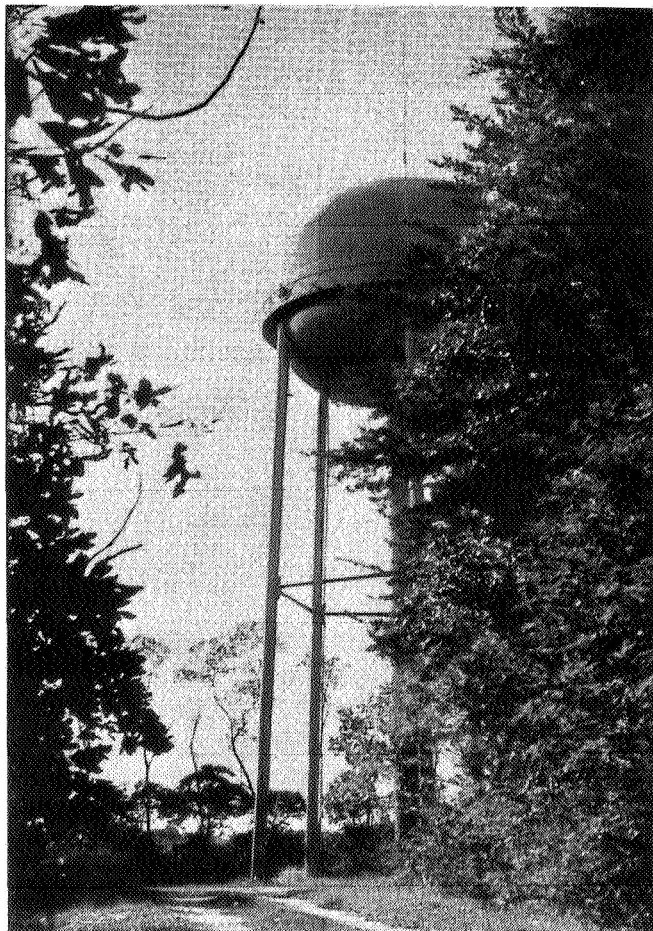

Fig. 15. Water tower seen from near its base.

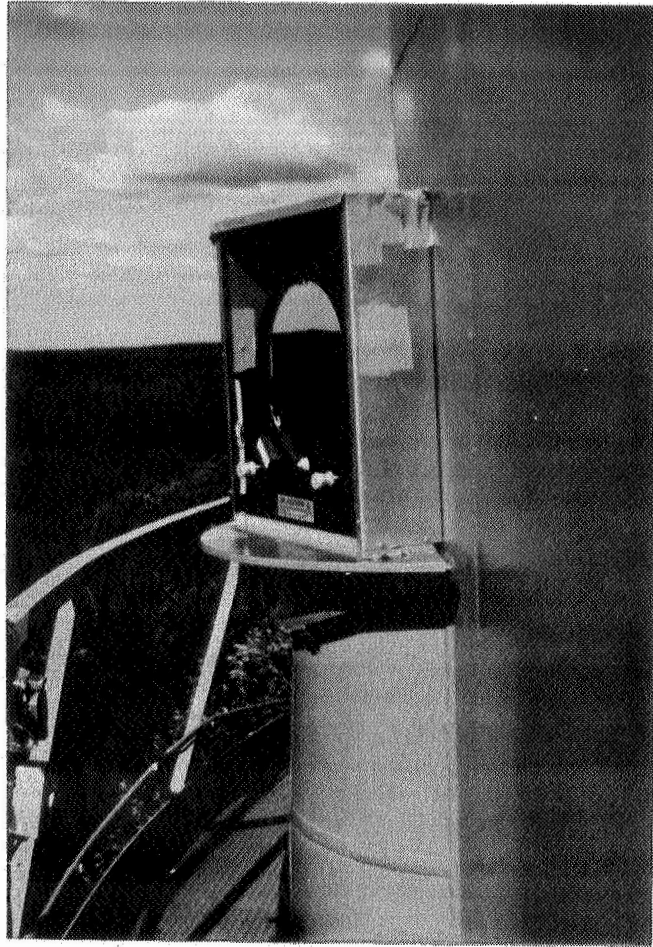

Fig. 16. 30 cm mirror on the water tower.

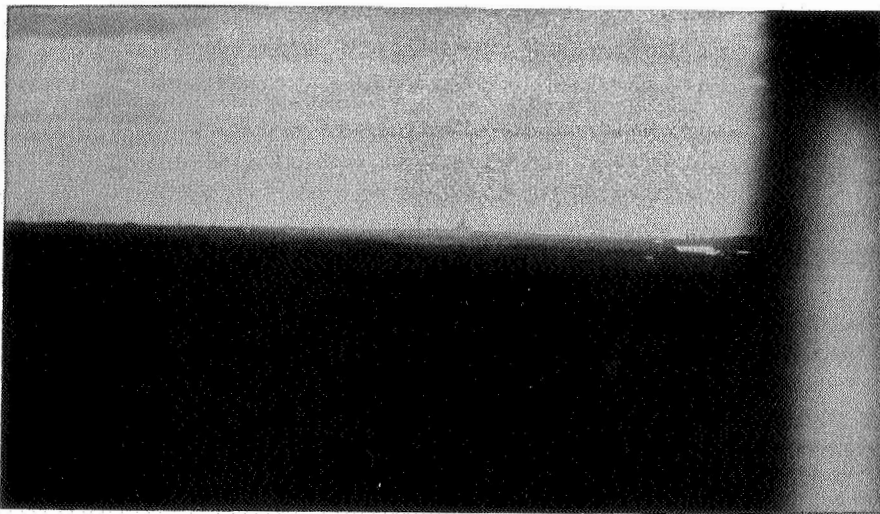

Fig. 17. National Cathedral on the horizon as seen from the water tower.

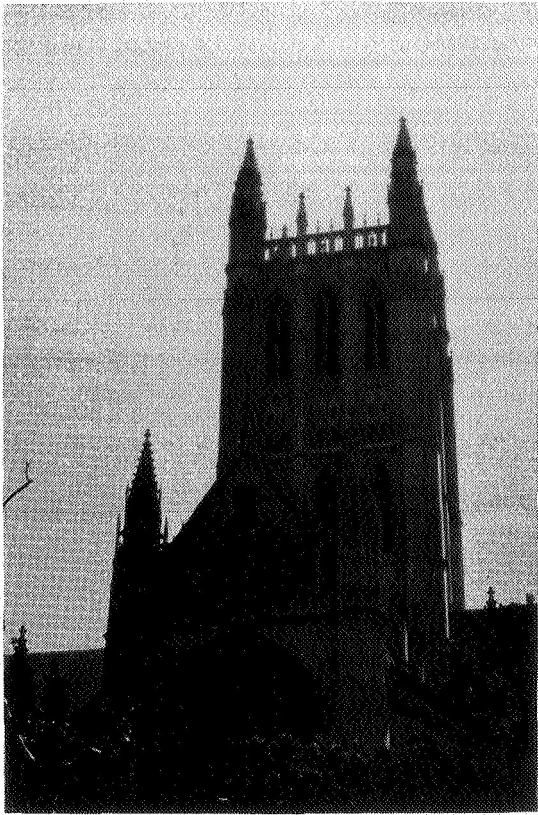

Fig. 18. Cathedral tower

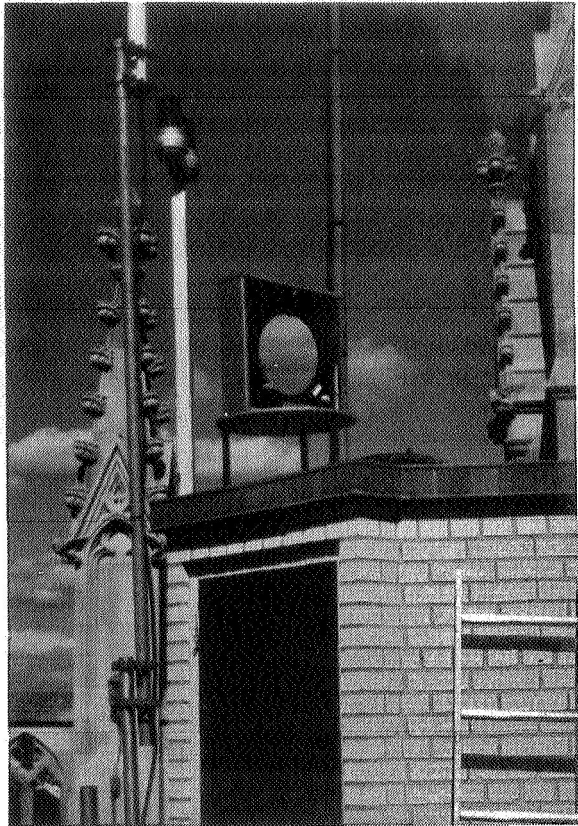

Fig. 19. Mirror on Cathedral tower.



Fig. 20. The USNO from the Cathedral tower.

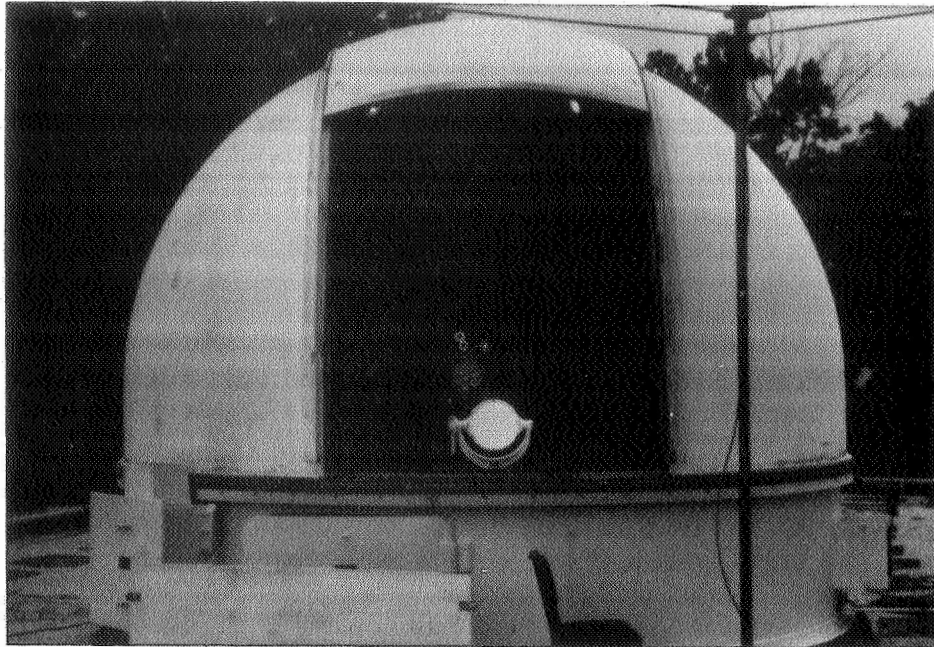

Fig. 21. Dome on the roof of the USNO Time Services Building.

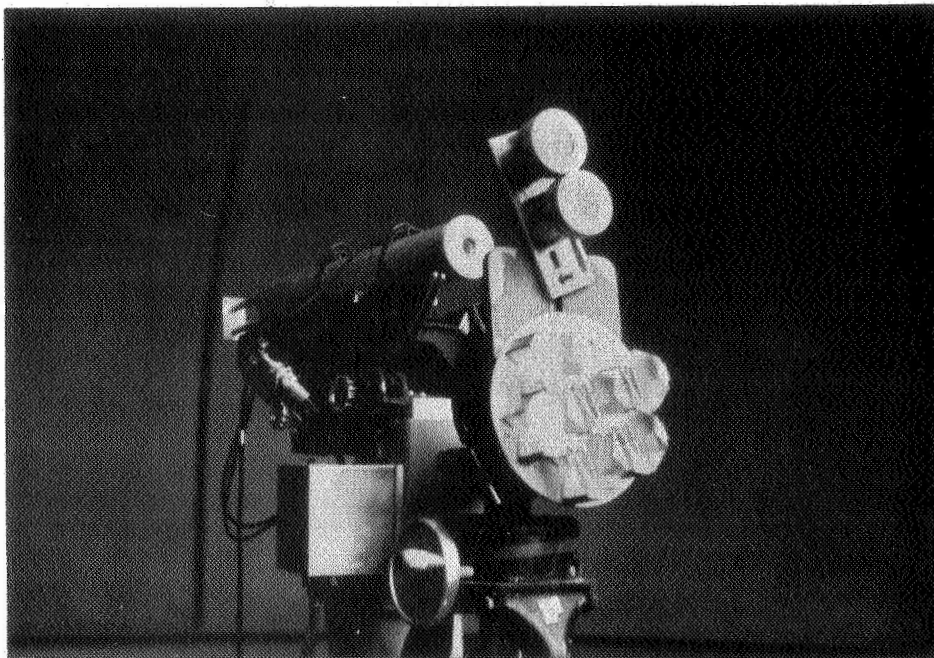

Fig. 22. Detector/reflector assembly at the USNO.

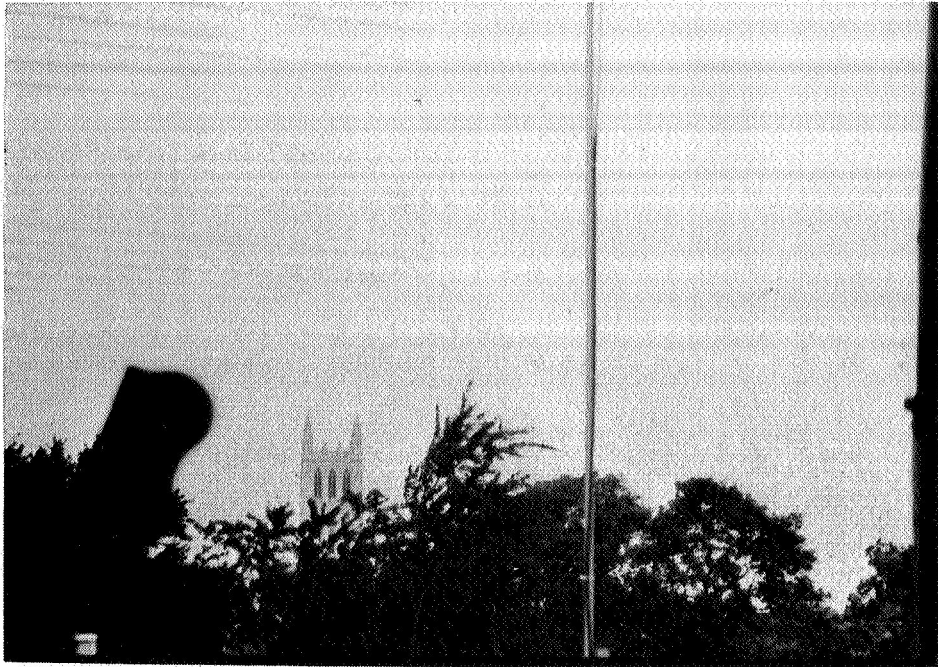

Fig. 23. Top of the Cathedral seen from the roof of the Time Services Building.

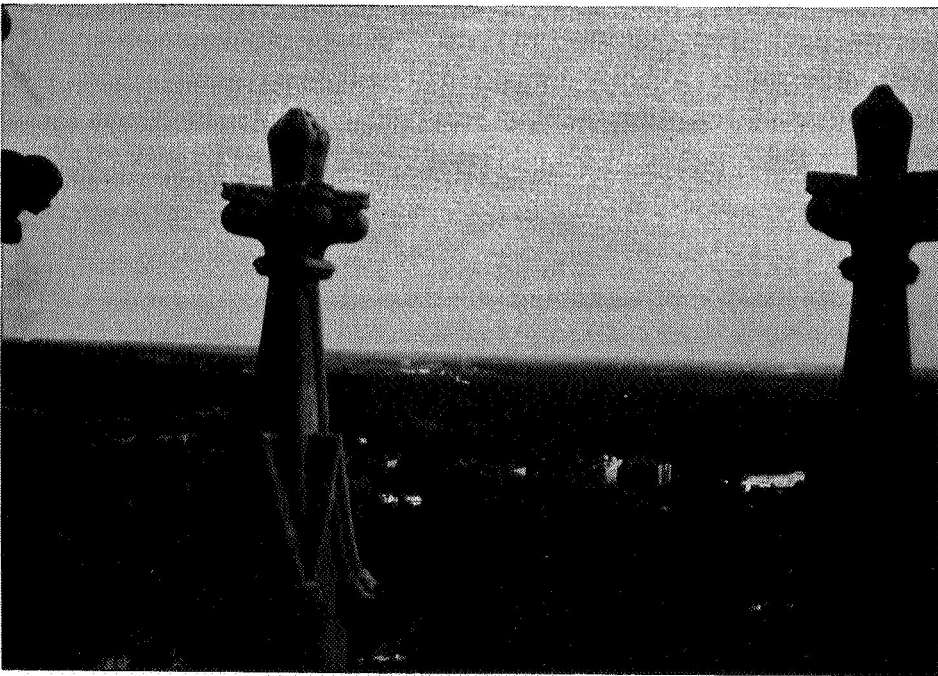

Fig. 24. Looking toward the water tower from the Cathedral.



Fig. 25. Domes of the Goddard Optical Research Facility reflected in the water tower mirror.

QUESTIONS AND ANSWERS

DR. KELLOGG:

What's the time constant for aligning the two mirrors that are at D?

PROFESSOR ALLEY:

Oh, No! Our electronics engineer, Mr. Steggerda is also an expert at lining that up and he can do it in a matter of 5 or 10 minutes, I guess. It takes a little longer than that to get all the equipment up on the water tower, and so on. But we typically can get a number of measurements done during an evening's run of several hours, provided the weather permits. We don't have to have freedom from cloud cover. In fact cloud cover is good because it stabilizes these vertical temperature gradients.

MR. KAHAN:

Can you work in rain?

PROFESSOR ALLEY:

No! No!

I should say that we checked with the airport forecasters -- visibility however they define it, and I don't know quite how they define it, but if it's less than 6 miles, we begin to get into trouble. We like to work with visibility of 15 to 20 miles but we can work with 5 or 6 miles. But we cannot work in rain or fog.

DISCUSSION ON GODDARD SATELLITE TIME TRANSFER

DR. WINKLER, The United States Naval Observatory

I think the discussion will take place. I should like to invite a few people here to join me at the table, certainly Dr. Decker, the project team leader of STIFT, and Mr. Starker, if he is willing to come up here. He has given us an excellent discussion of the German projects and could we ask somebody who's familiar with GPS time transfers to volunteer?

Nobody wants to volunteer? Yes, please, would you join us. I would also like to invite Professor Alley to come up and I think that we would have a little group and discuss the various aspects and summarize and ask questions. I would like the audience to be as active as possible.

Let me begin by giving you best regards from our European colleagues Dr. Bernard Serene; I talked with him yesterday morning to get some new information on the status of the LASSO project, and he regrets that he was unable to come, obviously, but on the news we received it appears as Professor Alley has already mentioned, that the LASSO is not dead.

In fact it's a very good chance that it might be a series of two successors, which will either be on a SERIES-2 type satellite, two experiments of course, or where it will be on METEORSAT as a piggyback effort. And then as mentioned by Professor Alley what we will expect, so that we will have to find out what is going to happen.

In looking over the papers which we have heard today and some of the papers which are still to come, and we have again the two classes of experiments of techniques: The one-way time transfers using a navigation system such as GPS, or such as TRANSIT and two-way transmission, using a communication satellite or using the ranging signals which are available on some of the other satellites, in the piggyback fashion.

I was very much intrigued by the slide shown by Mr. Starker today, about unscheduled and completely passive of comparison between Washington and PTB in Germany using completely different GPS receivers and achieving as we have heard a standard deviation of, something like 20 nanoseconds over a period of 10 days which includes all of the variations in the two clocks, in all the circuits and everything. And it includes the uncertainty of the GPS time transfer.

And just from that, but also when these experiences have been reported by David Allan and the NBS group and others. It is obvious that today we have the capability to synchronize any two clocks to about 20 nanoseconds wherever they are. Using the system which, in its original purpose, was far from being operational, but for a time transfer it is more than operational because we have five satellites which can be used and are being used.

Now, may I ask a couple of leading questions? We have heard today about the laser microwave time transfers and these super precision experiments and I would like to ask maybe anyone to answer here, how they see the future, and what role the laser is going to play in lets say 5 or 10 years from now, is it going to be a calibration tool or maybe it will become an operational tool?

PROFESSOR ALLEY:

The laser has the immediate disadvantage of not being able to go through clouds, at least in the powers available to civilian users. But, I think as a calibration technique it could play a very important part in the future.

I would think, for example, if we could calibrate using 1/10 nano-seconds laser pulses, the GOES positioning satellites are few, and the GOES positioning satellites were as they were tied directly to a master clock, for example, at the Naval Observatory then using the conventional readouts, one could improve on the global time transfer from the ten nano-second level down to the precision of which the GPS is capable which is at the one nanosecond, or perhaps even better.

DR. WINKLER:

That is certainly an interesting comment, because we hear about developments of clocks which are capable of keeping time down to the 10th of a nanosecond and it is a question what utility they would have without a better readout capability. That question has been raised several times, and I think it has not been answered satisfactorily.

I would like to ask Dr. Decker about his estimate, I mean that may be an indiscrete question; but it is a planning meeting and we ought to discuss these things as candidly as possible.

What is your present assessment of this STIFT experiment?

DR. DECKER:

Well, at the present time, this is a study place, so it's not an approved colloquium. And it is rather difficult to start any new program today because all agencies are suffering from budgetary problems.

The system, as presently studied by NASA, would be of benefit to a large outside user group and in order to get something like this going, I think one needs the support or the expression of interest from outside users to NASA to support the start of such a program.

So, at the present time, we do not have any committed start or start of the development of this STIFT system.

DR. WINKLER:

And so it is a concept, essentially, which is still looking for sponsors for support?

DR. DECKER:

That's right.

DR. WINKLER:

And as I heard, Mr. Starker, today, your experiment is apparently going in full force, is that true?

MR. STARKER:

Yes, you are right. It is in full force and it can be, and there is no doubt that it is a decision of great determination.

And to your question about laser or microwave links, I come from a microwave Institute, and I think that microwave links will be the operational tool for time transfer and laser will be used as a calibration tool, perhaps. And for us, not the highest experiencing is our aim in this first experiment with dual links. We find that the experimental technique to use a computer and a noise code as time signals, is a very important thing which can be used with communication satellites or with low-orbiting satellites, as well. And this is our aim and we made some experiments to offer as proof and we got also precisions of smaller than 1 nanosecond.

DR. WINKLER:

Your presentation presented us with such a wealth of interesting information and interesting details, I really think you should look very carefully through your panel paper.

But it appears to me that in Europe the schedules-- that it may be very wise for ESA to establish much closer relationships with this European group and find out how we could possibly participate --- what possibilities still exists? As we have heard, one of the main driving objectives in the German experiment is to gain experience in using clocks in space.

DR. DECKER:

I have a question. Do you have any plans in the future for this particular experiment? You said it was the first one?

MR. STARKER:

We would like to do it, but we have no plans, up to now.

DR. WINKLER:

Well, we can change the subject, in that this panel member say something about whose point of view they have in GPS satellites and time transfers.

MR. TALLEY:

Well, I guess there's at least one comment with regard to the laser and that's probably contrary to Dr. Alley's interest, we have never had a lot of interest trying to do laser tracking of one of our satellites in order to separate the ephemeris from our clock information. We recognize that as data base line, and many of us who are involved in clocks, are involved in the ephemeris evaluation are interested in that.

There has been considerable reluctance on the part on the program officers to sponsors such an activity. And they are still working it they are interested in NRL doing that, and the groundwork has been laid, and I --- well it hasn't happened yet.

DR. WINKLER:

Right now, I think there are two aspects which I don't think have been sufficiently emphasized. One is that the laser propagation is, from a physics point of view, a cleaner one. That you do not have to be this unknown dispersion; there is no noticeable, or not as large in the texture coming from the tropospheric water vapor. And the same thing is true from any atmospherics. True in principle, that's very interesting.

But there is a second aspect which I think that we should not forget, that it is intrinsically an ultra secure way of accessing a well-known object. It is much more secure than any microwave system ever is going to be. And I think that the program office has not considered that aspect yet. But I think it would be a very powerful motive to investigate the use of lasers for special purposes, in conjunction with very high precision calibration.

MR. TALLEY:

Would you like to have some status for the general audience as to where our GPS clocks are?

DR. WINKLER:

I think that would be most useful.

MR. TALLEY:

We have six navigation developmental satellites in orbit and four of those actually have the atomic clocks all running, two of which have the rubidium clocks and two of them cesium clocks running. We have NAVSTAR 1 and 2 radiating in L Band controlled by a crystal clock. NAVSTAR 1 is still being tracked with the KALMAN filter and it is being updated and has a NAV message that can be tracked. We have several satellites that are ready to be launched and are only waiting for a stage vehicle to put them up.

We actually have three vehicles in storage and the fourth one going into thermal vac tests this week. The development of the satellites themselves are almost done as far as the contractor is concerned for the first demonstration phase.

We are about 18 months late in launching our next one. We had a rather drastic propulsion failure in December of last year, just about a year ago now, and so that was a significant setback in getting them on orbit and now we have a heavier version of the satellite with what we call the secondary payload and we have to have a new stage vehicle. And that stage vehicle has had difficulties in terms of its nozzle. If and when that is solved we will be launching, but not before June of '83. The data that was shown on GPS comparison was not from a cesium clock but from a rubidium clock, which was on NAVSTAR 3.

DR. WINKLER:

That is a very interesting comment. Just by looking at the observatory data, its clock is performing extremely well and if it were not for the need to re-set it frequently because it has such a large rate due to its aging but it can be modeled as a quadratic state extremely well and over 10 days has residuals less than 10 nanoseconds using a quadratic model.

Unfortunately, you can't do it longer for about 14 days because then you see the recycle 500,000 microseconds the other way and change the frequency and your model needs to be picked up again because you don't know what actually happened to that clock, but the rubidium has the capability in space, in that particular case to give extra ordinarily good service.

Well, maybe we should invite some questions from the audience. Yes sir, could you please give your name for the record.

DR. ROBERT VESSOT, Smithsonian

I don't think that in the past there has been as great a discrepancy or difference between the alleged accuracy of the atomic clocks and the means by which this accuracy can be conveyed about the world?

I have a suspicion that the technology of clocks are out running our means for comparison at a greater rate now than ever before. I wonder if you care to discuss this point and the fact that at some point in time some action is likely to be needed, what action can be taken?

DR. WINKLER:

Any comments?

MR. TALLEY:

I have one comment with regard to GPS in this area. As far as our observation in orbit is concerned, from the GPS program point of view, it is through KALMAN filter observations at the master control station and if we look at two of the clocks one of which has a temperature coefficient on the rubidium and one has a suspicion of a variation in beam current in the cesium, the KALMAN doesn't show the diurnal effect. Yet we are highly suspicious that the clocks have these variations.

I think that the ability to look at the clocks on the ground has deteriorated to some extent.

We are working to try to separate that.

DR. WINKLER:

I happen to completely agree with him on his comments, that this is true. That, in fact, years from now, we're not going to have any means to utilize much better clocks which we can expect to have. I think that there are definite gaps in our planning and development. We are talking about many experiments but now not one of them will be useful at the one nanosecond level with the possible exception of the GPS system, but this will require some doing.

Further discussion on the clocks?

MR. WHITWORTH, JHU/APL

I'd like to ask what determinations have been made as to what sort of timing accuracy can be delivered to user spacecraft by GPS?

MR. TALLEY:

Well, it's a little out of my field, but I'll attempt to comment. I assume that we can, with the proper equipment on board, that we can approach the units nanoseconds transfer capability.

I think that that will take some special equipment that's not presently on board in satellites but it seems to be within the capability range.

DR. WINKLER:

I would like to add to that that I completely agree that we have to remember that we're still in the developmental stage and the learning phase and the operators who make the adjustments to operate the system are making deliberate changes from time to time and in order to gain experience.

I think some operational changes will be required to reach that but in my opinion, it's entirely possible to obtain the one nanosecond.

PROFESSOR ALLEY:

I'd like to address a question to Mr. Talley in relation to the question from the audience. I've heard that the GPS is now considering spacecraft to spacecraft communication and synchronization. Is it possible, tell us more about this plan.

MR. TALLEY:

Well, you've heard right. There is a significant study in that area. It is not to improve the performance that we've been demonstrating in this phase one, it is addressing a survivability question, an autonomy out beyond 14 days; up to, like, 180 days. It is true that it is being worked and studied. It would require considerably more computational capability on board the spacecraft than is currently available but it does appear to be feasible in concept form.

PROFESSOR ALLEY:

Do the antennas permit this sort of thing or will new antennas be required?

MR. TALLEY:

I believe that the antennas would be satisfactory.

DR. WINKLER:

Are there any more questions?

MR. ALLAN:

Mr. Starker, I'd like to also congratulate him on an excellent paper but my one comment in regard to that is that between his site and PTB there's a very short baseline and using GPS in common view you could probably appreciate about one nanosecond because of the large removal of the ephemeris error and we would of course, be extremely interested in that tie. In the February time frame, we will loan one of the NBS type receivers to the PTB and you would be able to conduct such an experiment. This would give you a tie to PTB at the one nanosecond level.

DR. WINKLER:

Can I repeat? One of the results which you reported at the Frequency Control Symposium that over a period of 2 or 3 weeks the residuals in common view mode between NBS and Washington using precisely the same satellites, the time difference in data, was on the order of 2 nanoseconds.

MR. ALLAN:

That's correct.

MR. STARKER:

We would be very interested in such measurements and as soon as the PTB would have the GPS receiver, we would have also the possibility to calibrate our receiver which is delayed up to now.

PROFESSOR ALLEY:

I'd like to return to our earlier discussion, Mr. Starker. I don't want to leave the impression that the STIFT planners have not had that kind of mutual interest but they did not find anyone within the NASA organization.

DR. WINKLER:

Not up until now. Any more question, please? I would like to ask about GPS denial of access to time?

MR. TALLEY:

Well, again, this is not something that I worry about and talk about every day. But it does border on a classified type of discussion. I personally suspect that before the system goes operational there will be contamination of the GPS signal as we know it today. I think it will not be such that -- recognized users would still be able to decode it and make it available in a sense that it would still be useful.

DR. WINKLER:

Maybe we can shorten the discussion if we say -- I should have mentioned that the paper which was given, I believe one or two years ago, at this conference by somebody from the GPS Program Office. I think it was Capt. Tennant. I want to know whether any significant change has occurred?

MR. TALLEY:

I don't recall exactly his position, I was here when he gave the paper; gave his talk. I believe that he did give some assurance that the signal would not be contaminated and I believe that that is not correct and that is how things stand today.

I believe that Dave Allan is aware of the type of contamination that is expected and maybe he would care to comment on how civilian users would react to the contamination.

MR. ALLAN:

Basically, I think we cannot talk about these kinds of techniques, but the common view approach would eliminate some of the problems that would be encountered and I think this will allow us to still use the system even under some disturbed circumstances.

So, I think that the system will be continued.

DR. WINKLER:

Instinctively, I have a feeling that the system is of very great use right now.

On the other hand, we have to be prepared. Not one of the systems can be guaranteed to work when we need it and there is nothing more important in time systems than to have a common interface to allow us to get time from one of the other many coordinated systems.

That's the whole purpose of coordination.

Well, I think, Mr. Chairman, that we have finished now and I thank you very much.

MR. KAHAN:

I would like to thank all of these speakers this afternoon.