

NEW AUTO-TUNING TECHNIQUE FOR THE HYDROGEN MASER

R. L. Sydnor and L. Maleki
Jet Propulsion Laboratory
California Institute of Technology
Pasadena, California

ABSTRACT

Auto-tuning of the maser cavity compensates for cavity pulling effect, and other sources of contribution to the long term frequency drift. Schemes previously proposed for the maser cavity auto-tuning can have adverse affects on the performance of the maser. In this paper we propose a new scheme based on the phase relationship between the electric and the magnetic fields inside the cavity. This technique has the desired feature of auto-tuning the cavity with a very high sensitivity and without disturbing the maser performance. Some approaches for the implementation of this scheme and possible areas of difficulty are examined.

Introduction

The dominant cause of the long term frequency drift in the hydrogen maser is the slow change in the dimensions of the high Q cavity. Since the dimensions of the cavity must be held stable to approximately one angstrom to maintain the frequency of the maser to one part in 10^{15} , it is difficult to directly measure and control. This dimensional change must be overcome in some indirect manner which senses the cavity frequency offset and tunes the cavity back to resonance. Aside from overcoming the cavity pulling effect, auto-tuning can also enhance the performance of the maser by reducing the sensitivity to pressure variations, and compensating for anomalous frequency shifts often encountered in the hydrogen maser.

A number of techniques have been previously proposed for cavity auto-tuning.¹⁻⁴ These techniques are essentially based on either the modulation of the atomic line width, or the sensing of the cavity resonance. The technique proposed in this paper is based on the latter effect, and utilizes the phase relationship between the electric and the magnetic fields in a finite Q cavity.

In the remainder of this paper brief discussions of cavity auto-tuning methods based on atomic line width modulation and on resonance sensing will first be presented. The description of the auto-tuning scheme based on phase detection will then be given. Finally, a discussion of the potential advantages and disadvantages, and possible means of the implementation, of the method will be made.

Cavity Auto-Tuning Techniques Based on Line Width Modulation

The line width modulation technique is based on the influences of the quality factor, Q , of the atomic line, the Q of the maser cavity, and the mistuning of the cavity on the output frequency, f_0 of the maser. Designating the deviation of the oscillator frequency from true resonance by Δf_0 , the cavity frequency mistuning by Δf_c , and the cavity and line quality factors by Q_c and Q_1 , respectively, we may write,

$$\Delta f_0 = (Q_c / Q_1) \Delta f_c \quad (1)$$

According to equation (1), the mistuning of the cavity may be determined by changing the atomic line width. There are several ways in which this may be accomplished. In the first, and most common way, it is accomplished through the controlled modulation of the atomic beam flux, which in turn influences the contribution of the spin exchange effect to the line width.¹

The modulation of the atomic flux may be accomplished in a number of ways, including the modulation of the input power of the hydrogen gas dissociator. The most popular method for atomic beam flux modulation however involves the chopping of the beam and thus controlling the number of atoms which enter the maser storage bulb in the cavity. The resulting change in the maser output frequency is detected and used to determine the cavity mistuning and thus to control the effect of the cavity drift. While this method has the advantage of simplicity and effectiveness, it nevertheless suffers from a number of problems including reproducible control of the beam chopper and adverse influence on the performance of the maser due to periodic alteration of the signal-to-noise ratio in the maser and the effect of the varying output power on the phase transfer function of the electronics.

Another technique for varying the width of the atomic line that has been attempted is the introduction of inhomogeneities in the magnetic field in the maser cavity. The resulting frequency change in the maser output frequency would be detected and used as above. This technique has not been used because of the difficulty in achieving the proper kind of controlled inhomogeneity.

Cavity Resonance Sensing Technique

A number of techniques have been devised, in connection with the development of the passive hydrogen maser,² to auto-tune the cavity by sensing the cavity resonance. One such technique² involves the injection of a signal which has been square-wave frequency modulated by an amount approximately equal to the band-width of the cavity, and is centered on the atomic line. If the cavity is not tuned correctly, the two signals will be attenuated by different amounts as they traverse the cavity. This modulation of the amplitude of the injected signals is then used to generate an error signal which corresponds to the difference between the cavity resonance frequency, and the frequency of the injected reference signal.

A somewhat similar technique employs a signal centered on the atomic line which has been modulated by a sine wave to produce two side-bands

approximately one cavity band-width apart, with a carrier suppressed far enough to not perturb the maser operation.³ The modulation of the amplitude is again used to generate an error signal which is used to tune the cavity to resonance. Finally, in yet another technique⁴, the cavity center frequency is square wave modulated about the hydrogen line frequency. The modulation of the amplitude is again used to measure the frequency offset.

While all three techniques mentioned above are effective in cavity auto-tuning, they nevertheless involve either the introduction of a signal in the cavity, or modulation of the cavity frequency. In either case it is difficult to prevent the introduction of noise in the cavity and modification of the maser performance. Furthermore, these techniques are difficult to implement, and require the use of low noise and high performance electronic components which are difficult to develop.

Cavity Resonance Sensing by Phase Comparison

In a resonant cavity the energy is stored in both the electric and the magnetic fields. For a cavity of infinite Q, the **E** and **H** fields are in temporal and spatial quadrature. For a lossy cavity the temporal phase becomes an arccotangent function of the fractional frequency offset of the signal frequency from the cavity center frequency, normalized to the cavity bandwidth. This fact is illustrated by the input impedance of the cavity shown in the Smith chart of Figure (1). The cavity input impedance is small far from resonance, and complex near resonance. At resonance, the input impedance is real. This, too, implies that the phase of the electric and the magnetic fields may be used to determine the cavity resonance.

The development of a cavity auto-tuning system based on the ideas sketched above can be illustrated by the following, not necessarily optimum, technique. Two co-located, weakly coupled probes, one loop and one dipole, can be used to detect the magnetic and the electric fields in the cavity. Signals from each probe may be compared in phase in a manner similar to that illustrated in figure (2). A deviation of phase from 90 degrees as detected by the phase detector in figure (2) will then signal the departure of the cavity from resonance condition. The signal from the phase detector may be used in conjunction with the varactor to auto-tune the cavity back to resonance.

The sensitivity of this technique in tuning the cavity may be illustrated by a simple calculation. Let us assume typical values of 35000 for the Q of the maser cavity, and 10^9 for the hydrogen line Q. Designating BW for the cavity bandwidth we have $BW=40571$ Hz with these parameters. The cavity bandwidth corresponds to a phase shift of 90 degrees. Assuming a sensitivity of 1×10^{-6} radian for the phase detector, the technique will be sensitive to a fractional frequency deviation of 4.6×10^{-16} .

The implementation of the phase sensing of the cavity resonance will require careful design of the probes and their location, as well as low noise amplifiers for the detection of the signal. Nevertheless, this method, unlike the other cavity sensing techniques mentioned above, dispenses with

the need of injecting signals in the cavity and therefore does not adversely affect maser performance.

Summary

We have examined a sensitive technique for auto-tuning of the hydrogen maser cavity. The technique is based on detecting the phase relationship between the magnetic and the electric fields in the cavity with appropriate probes to maintain the resonance condition.

Because of dispensing with the need of signal injection in the cavity, or modulation of the cavity frequency, the proposed scheme has the apparently attractive feature of auto-tuning the cavity without adversely influencing the maser performance. It is clear, however, that the implementation of this technique in the hydrogen maser requires care to insure effective tuning without disturbance of the maser performance. In particular, light coupling of the **E** and **H** probes requires low noise amplifiers with little sensitivity to temperature variations. The position of the probes in the cavity, and with respect to each other, should also be carefully chosen to ensure maximum signal with minimum disturbance to the maser power.

Preliminary investigations in our laboratory, however, has yielded promising results for this technique. We are also investigating probe configurations and sensing schemes that will enable the implementation of this technique effectively, in newly designed and existing masers.

Acknowledgements

This paper presents the results of one phase of research carried out at the Jet Propulsion Laboratory, California Institute of Technology, under contract sponsored by the National Aeronautics and Space Administration.

REFERENCES

1. Kleppner, D., Goldenberg, H. M. and Ramsey, N. F., Phys. Rev. 126, 603 (1962).
2. Audoin, C., Revue Phys. Appl. 16, 125 (1981).
3. Wang, H. T. M., Proc. 34th An. Symp. on Freq. Control, (Philadelphia, PA, 1980) p. 364.
4. Peters, H. E., Proc. 36th An. Symp. on Freq. Control, (Philadelphia, PA, 1982) p. 240.

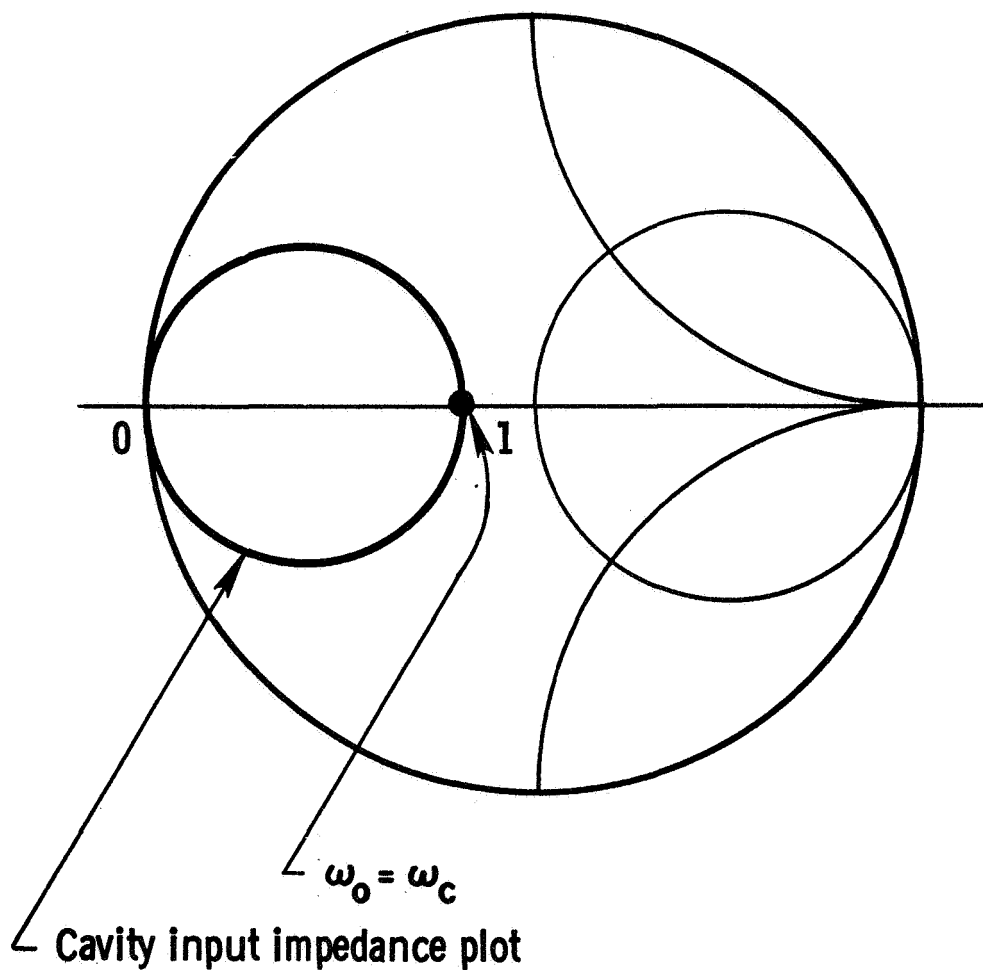
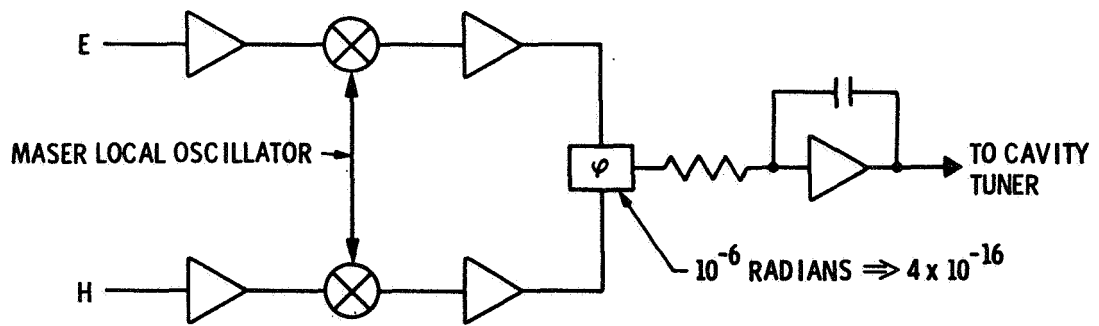

Fig. 1 Normalized cavity input impedance versus frequency presented on a Smith chart.



ELECTRONIC BLOCK DIAGRAM

FIGURE 2