

PERMANENT-MAGNET MOTORS AND GENERATORS FOR AIRCRAFT

E. F. Echolds

AiResearch Manufacturing Company
Torrance, California 90509

This presentation covers electric motors and generators that use permanent magnets to develop their flux fields. Most of the discussion is on the rotating machinery, but aspects of control and power conditioning are also considered. The discussion is structured around three basic areas: rotating machine design considerations presents various configuration and material options, generator applications provides insight into utilization areas and shows actual hardware and test results, and motor applications provides the same type of information for drive systems.

ROTATING MACHINE DESIGN CONSIDERATIONS

Permanent magnets can be used in a variety of configurations. Most applications are radial air-gap designs. The high-energy permanent magnets (fig. 1) that are in use today have very low tensile strength. Structural support is typically accomplished through the use of a shrink sleeve, which assures a continuous compression load on the magnets at all rotational speeds and temperature extremes. The sleeves can be of nonmagnetic or bimetallic material. The rotor with the radial magnets is the lowest cost construction method. Construction using tangential magnets allows a larger number of poles and a higher flux density since two magnets feed one pole piece.

The development of permanent-magnet alloys combining rare earths and cobalt, principally samarium cobalt, over the last 10 years has produced materials of more than twice the energy product of earlier magnets like AlNiCo 9. In addition, the coercive strength, or resistance to demagnetization of samarium cobalt, makes it ideal for motor and generator applications. It can work effectively into relatively large air gaps and will not permanently demagnetize when subjected to overload currents. The demagnetization curves are shown in figure 2 for two grades of samarium cobalt and AlNiCo 9 for comparison.

High-speed or high-performance electromagnetic machinery operating with samarium-cobalt magnets will often be limited in design by the ability to cool the stator assembly. Air cooling is the simplest method of stator cooling. Air can be directed through the machine, over the housing, or both. A more sophisticated method is liquid cooling by means of a housing heat exchanger. The maximum effectiveness is reached in a "wet" winding configuration, where the coolant is brought into direct contact with the stator copper. Stator cooling types are shown in figure 3. Fluid cooling is more effective than air cooling, and the liquid-cooled housing is the most reliable of the cooling methods shown.

To optimize a machine for any application, a large number of variables must be assessed. AiResearch Manufacturing Co. has developed a program, called BIGMAG, that is capable of operating in either a motor or generator mode. When given the desired machine power and speed, the program can optimize the design around any desired parameter, such as weight or efficiency, while operating within prescribed design constraints, such as machine reactance or rotor tip speed. The output from the program provides a complete description

of the stator and the rotor as well as the loss distribution and input and output power at a variety of load conditions.

GENERATOR APPLICATIONS

The voltage and frequency of a permanent-magnet generator are directly proportional to speed. Most generator applications require operation over a significant speed range. Since the output is at constant volts per hertz, some of the unconditioned power can be used directly. Where regulated and conditioned power is required, ac, dc, or a combination can be achieved with power semiconductors. The control can be done either at the generator or at the utilizing equipment, depending on the transmission considerations and the environment or space available in the specific situation.

A samarium-cobalt permanent-magnet generator built by AiResearch for the Naval Air Development Center is shown in figure 4. The power-conditioning electronics, in brassboard form, are packaged beneath the rotating machine. Thyristors are used for the control capability over a 9000- to 18 000-rpm generator speed range.

The 8-pole rotor assembly shown in figure 5 displays the significant features of a tangentially oriented magnet configuration. The steel pole pieces have holes for weight reduction. The rotor support sleeve is beryllium copper. Extensions of the nonmagnetic center hub complete the rotor shaft.

One of the key features of the permanent-magnet generator is the transient voltage response to step load changes (fig. 6). There is no electromagnetic field time constant to delay the flux field correction. The inherent regulation of the machine controls the maximum voltage excursion on application or removal of load. The terminal voltage is electronically corrected by changing the control thyristor firing angles to achieve the desired steady-state voltage. The test data taken on the 270-V dc generator show the unit capability in comparison with specification requirements under a full 100-percent step load change.

The dimensions and weights of the 45-kW, 270-V dc generator are shown in figure 7. The generator includes a quick disconnect, which is essential in a permanent-magnet machine. Because the generator excitation cannot be removed in case of an internal fault, it is necessary to disconnect the generator from the drive pad in order to interrupt the fault current. This disconnect has been tested and therefore represents actual sized hardware. The final package size for the control electronics is also represented in the figure. The weights shown in the figure represent a design of 3 or 4 years ago and could be reduced in a new design.

One interesting area of application for the permanent-magnet rotating machine is its dual use as a main engine starter and generator. With more sophistication added to the control logic, the power thyristors can be used to commutate the unit as an engine starter motor and then to switch mode when the engine is up to speed to provide aircraft electric power. AiResearch performed a design study for a 150-kW starter-generator. The higher frequency results in a smaller machine, but for large aircraft transmitting power at high frequency presents voltage drop problems. For smaller (fighter type) aircraft with shorter cable runs, the high-frequency machine might still be attractive. For commercial airliners and large military aircraft, the low-frequency option appears to be preferable. The high- and low-frequency options are compared in table I. It should be noted that the high-frequency, high-speed machine has a significant advantage in electromagnetic weight over the low-frequency, low-speed machine.

Permanent-magnet motors provide considerably more flexibility than conventional 400-Hz motors. Because there is no inherent speed constraint, the motor can be matched to the drive requirement rather than forcing the driven equipment off optimum design. When full-power output from a pump, fan, or compressor is not required, the drive motor speed can easily be reduced by the control electronics to reduce energy consumption. The controller also permits limitation of inrush currents on startup. Even current limited, the starting torque of a permanent-magnet motor tends to exceed that of an induction motor of equivalent size. The disadvantage is that the power is handled through solid-state devices. The ultimate goal is energy savings.

The application of permanent-magnet motors in aircraft systems is quite broad and includes variable-speed compressors, primary and secondary flight controls, variable-speed fuel pumps, variable-speed fans, and other actuation and motor systems. Key areas are those in which the high-speed and variable-speed features are useful. In addition, permanent-magnet motors are ideal for servoapplications in flight control systems. The high torque-to-inertia ratio and control characteristics are ideal for servosystems. General actuation and drive motor uses such as landing gear actuation and valve position drives are also suitable.

Motor converters can use thyristors, transistors, or a combination of the devices in their power-switching circuits. In general, for higher power levels, thyristors become more attractive because a single thyristor can handle more power than a single transistor. Paralleling of devices has been done successfully, but it does affect system complexity and cost. A good example of a thyristor system would be a double-bridge arrangement where the variable-speed generator output would be rectified, voltage would be controlled by the first three-phase thyristor bridge, and the motor-switching commutation would be done in a second thyristor bridge. For power applications of 60 hp or less, transistors can be used with only two transistors per leg. Control and commutation in one bridge circuit would be provided by modulating the six transistors in the system when they were conducting during their commutation function. Transistors, because of their superior control characteristics and growing power-handling capability, will be used in most aircraft converter applications.

AiResearch continuously monitors state-of-the-art power transistors suitable for power-conditioning equipment. Internally funded research programs allow for both testing and evaluation of such devices. As part of the research programs, AiResearch has designed and built a special high-power transistor test console, shown in figure 8. The console provides an effective tool for complete device characterization in both chopper and inverter modes of operation. This is a necessary effort to determine how transistors will operate in the final circuit.

Performance testing has been completed on a 26-kW, 26 000-rpm samarium-cobalt motor driven from a dc line. The control approach uses a series transistor chopper feeding a thyristor bridge. The efficiency of the motor is shown in figure 9 over a 4:1 speed range and a 4:1 shaft torque range. The excellent efficiency characteristics show the potential for energy savings where variable speed is desired.

AiResearch has also developed a primary flight-control actuator under a contract from the Air Force Flight Dynamics Laboratory at Wright-Patterson Air Force Base. This design, shown in figure 10, uses two samarium-cobalt motors, since a completely redundant system was required. The motors are six-pole machines with tangential magnet orientation operating at 9000 rpm at the full 270-V dc input. The performance characteristics of this actuation system are

summarized on the figure. The motor alone is approximately 3.5 in. in diameter and 8 in. long.

High horsepower can be achieved in relatively small machines if high-speed operation is acceptable. However, small motors operating at high speeds introduce significant cooling considerations. In addition, the maximum horsepower that can be achieved at a given speed is limited by the rotor diameter and the rotor length-to-diameter ratio because of critical speeds and other dynamic problems. Figure 11 illustrates a safe operating region for machines designed with radial magnets and shows the general characteristics of the power limitation with respect to speed. The absolute power limit for a given speed is dependent on application details. This curve can be improved by using other design techniques; however, the basic message is that for large horsepower machines, the speed will be limited.

TABLE I. - COMPARISON OF 150-kw GENERATOR-STARTER MOTORS

	<u>HIGH FREQUENCY</u>	<u>LOW FREQUENCY</u>
SPEED	18,990	14,250
POLES	8	4
FREQUENCY	1266	475
DIAMETER	5.81	8.27
LENGTH	9.38	12.88
ELECTROMAGNETIC WEIGHT	50.88	84.50

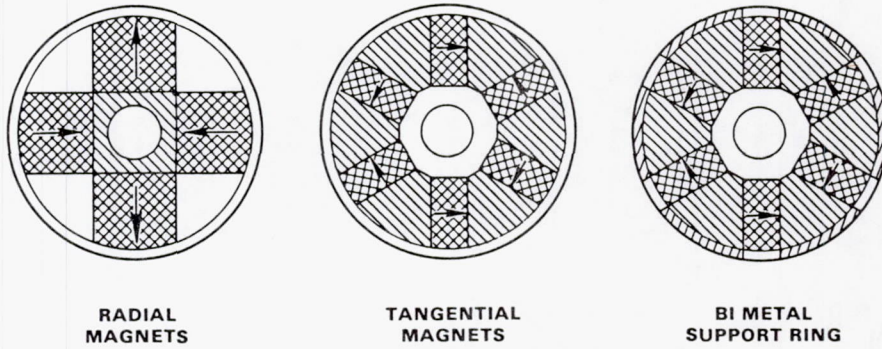

Figure 1. - Permanent-magnet rotor types.

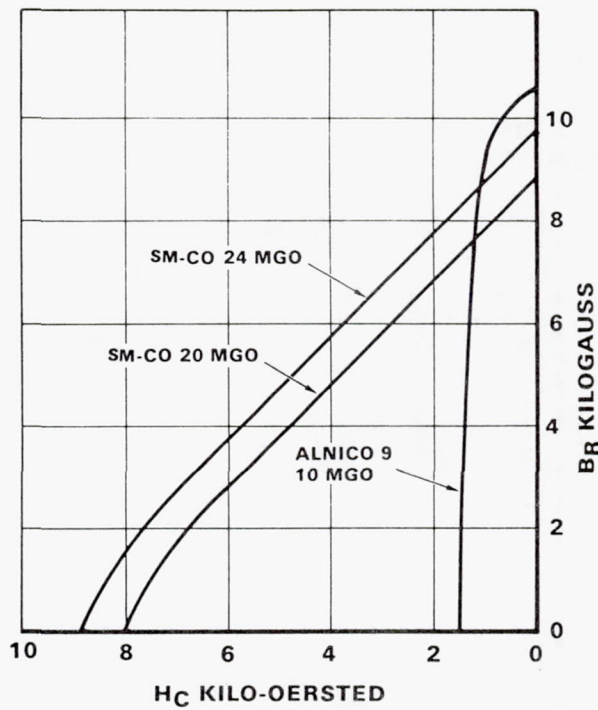

Figure 2. - Permanent-magnet alloy improvements.

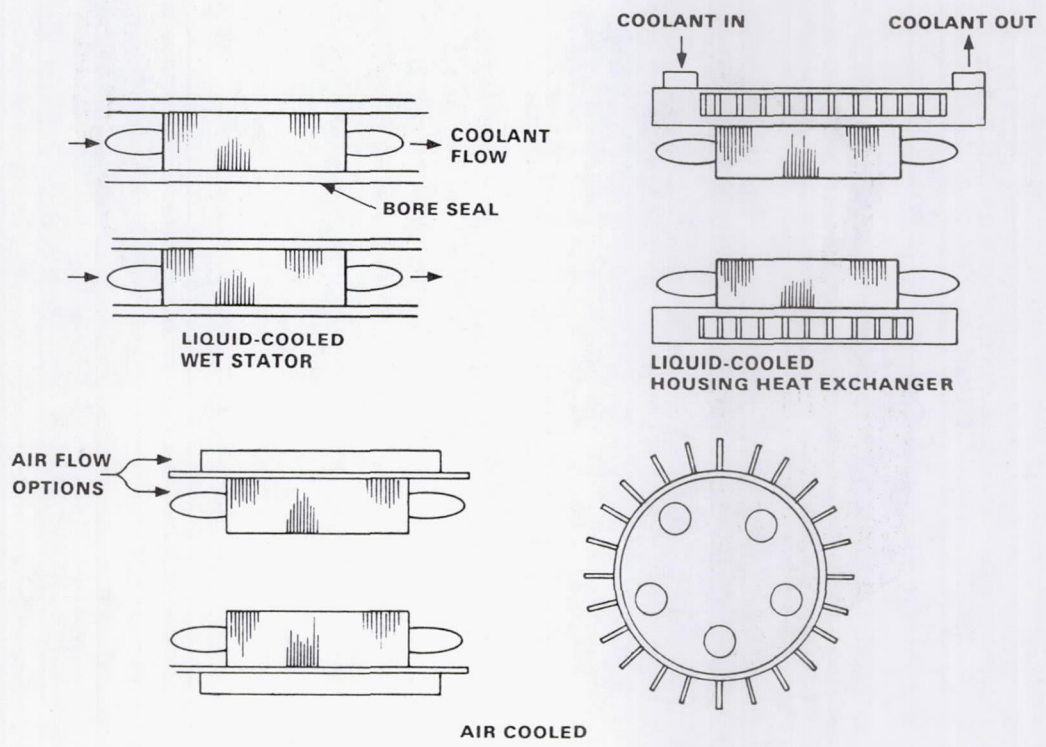

Figure 3. - Stator cooling types.

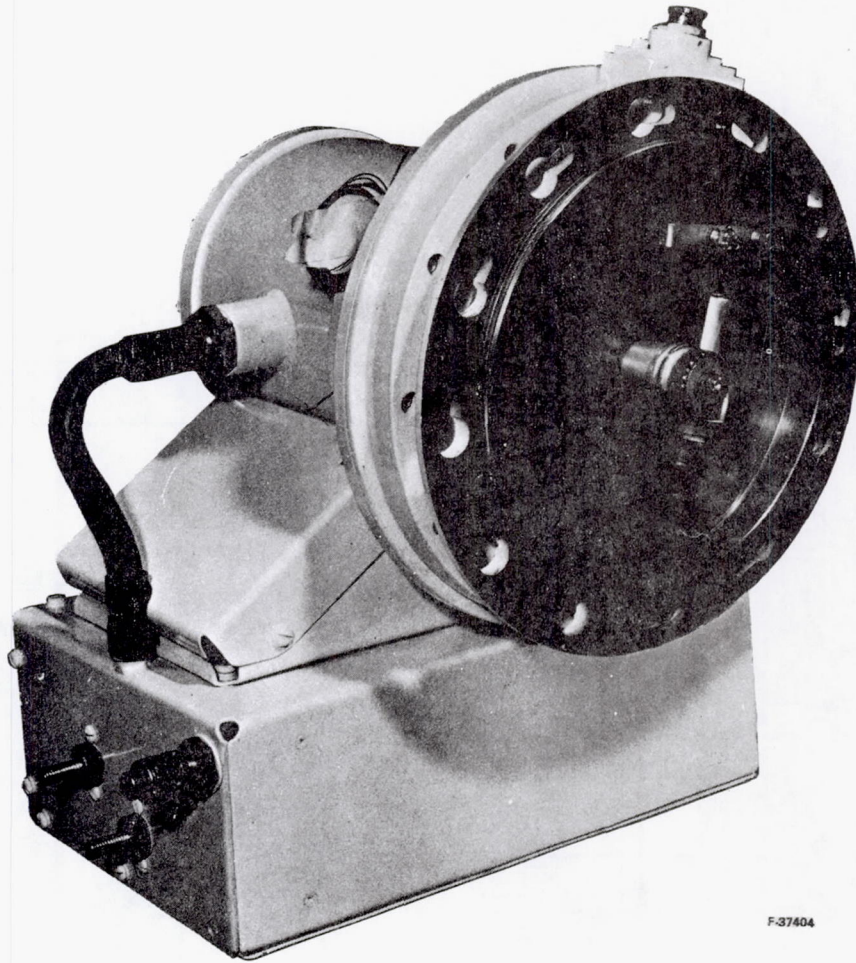

Figure 4. - 270-V dc, 45-kW permanent-magnet generator.

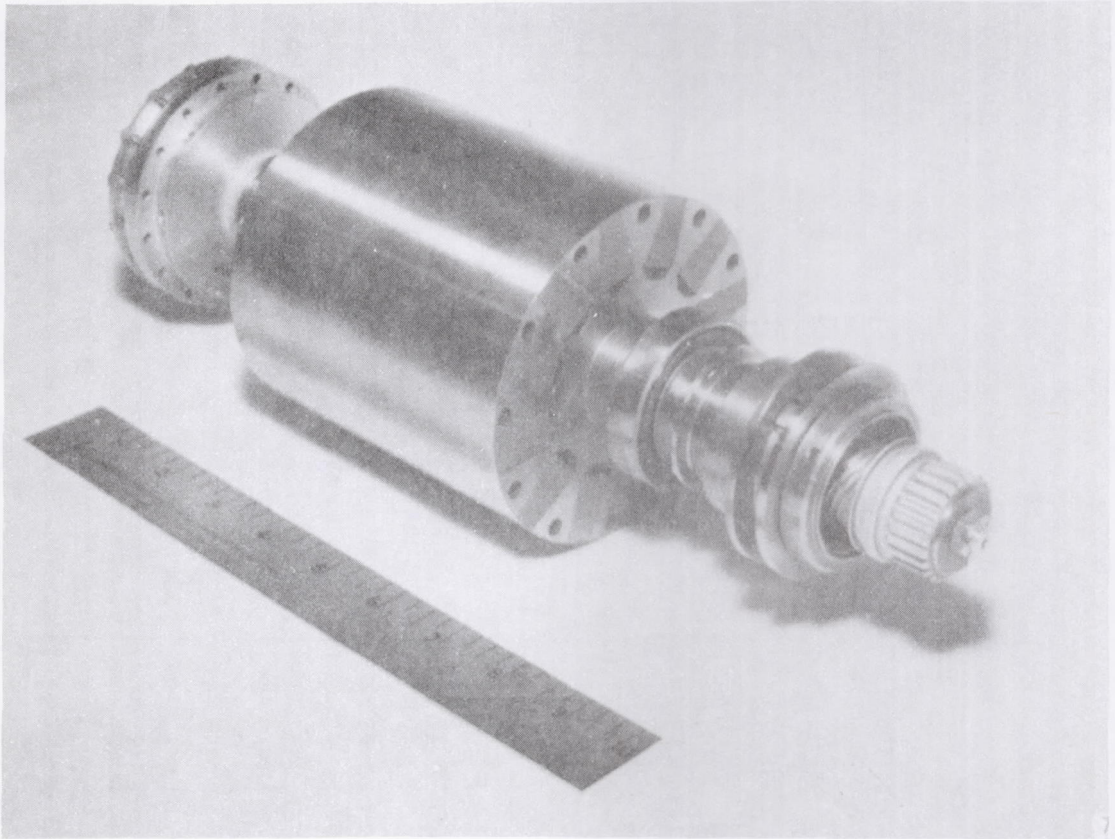

Figure 5. - 270-V dc generator rotor assembly.

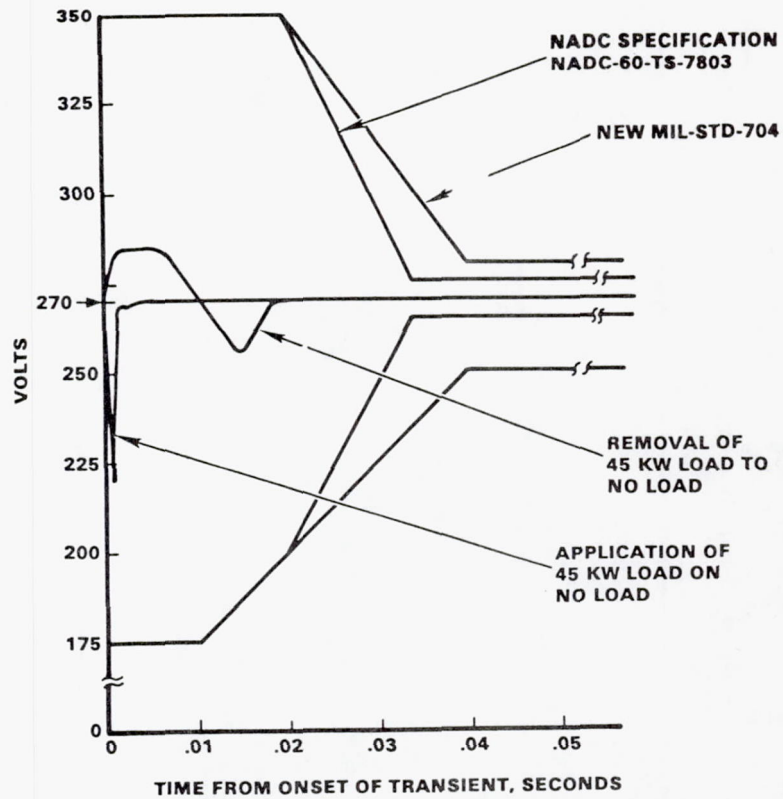

Figure 6. - Transient response of 270-V dc generator system.

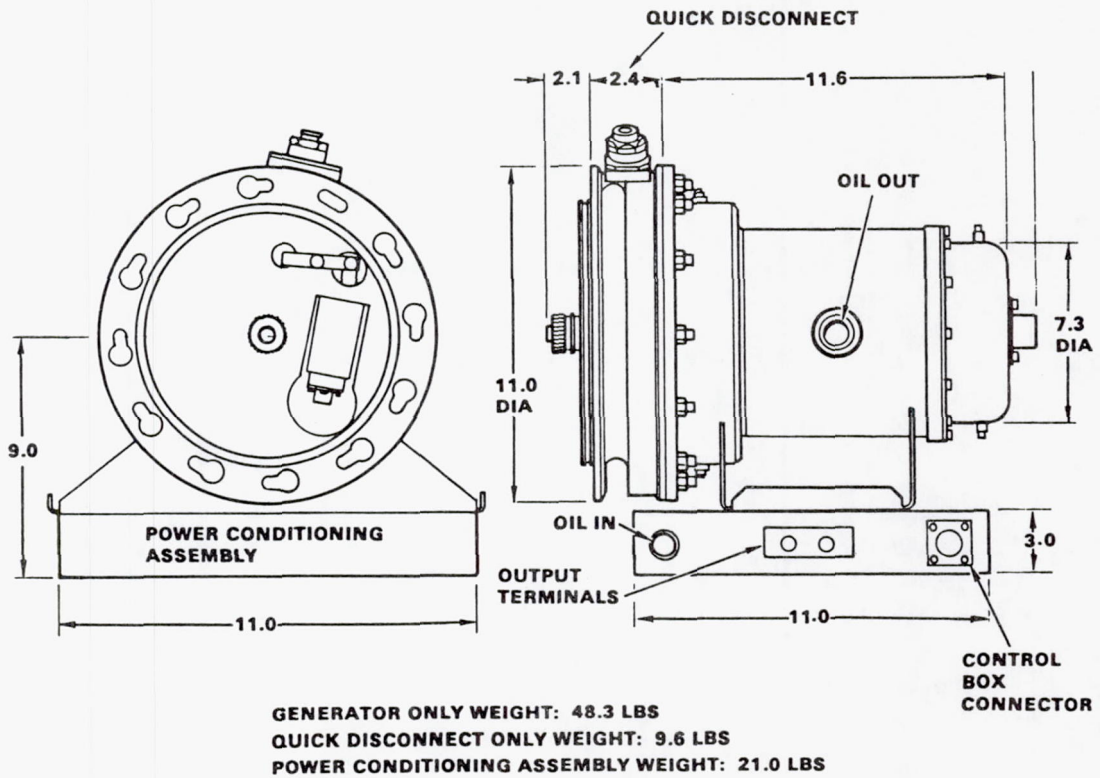
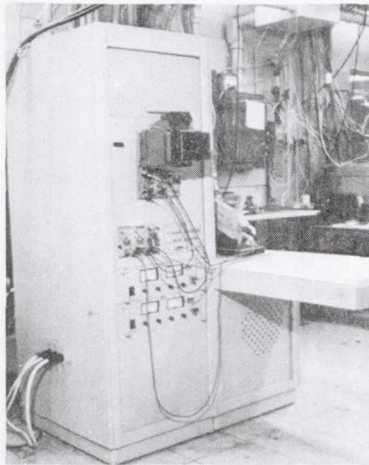

Figure 7. - 270-V dc, 45-kw generator and power conditioner assembly.

- DESIGNED AND BUILT BY AIRESEARCH
- EFFECTIVE DEVELOPMENT TOOL



TEST CAPABILITIES

- DEVICE CHARACTERISTICS
- COMPLETE CHOPPER EVALUATION
- COMPLETE INVERTER EVALUATION

RATINGS

- 0-600VDC @ 300A INPUT
- 0-2000ADC LOAD CAPABILITY
- 0-100KHZ FREQ CAPABILITY

Figure 8. - High-power-transistor tester.

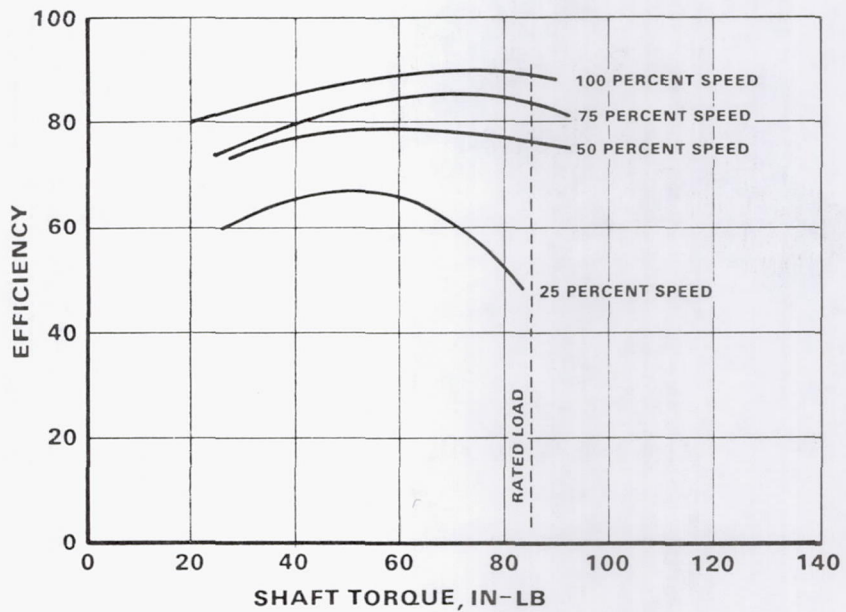

Figure 9. - Typical performance of variable-speed motor.

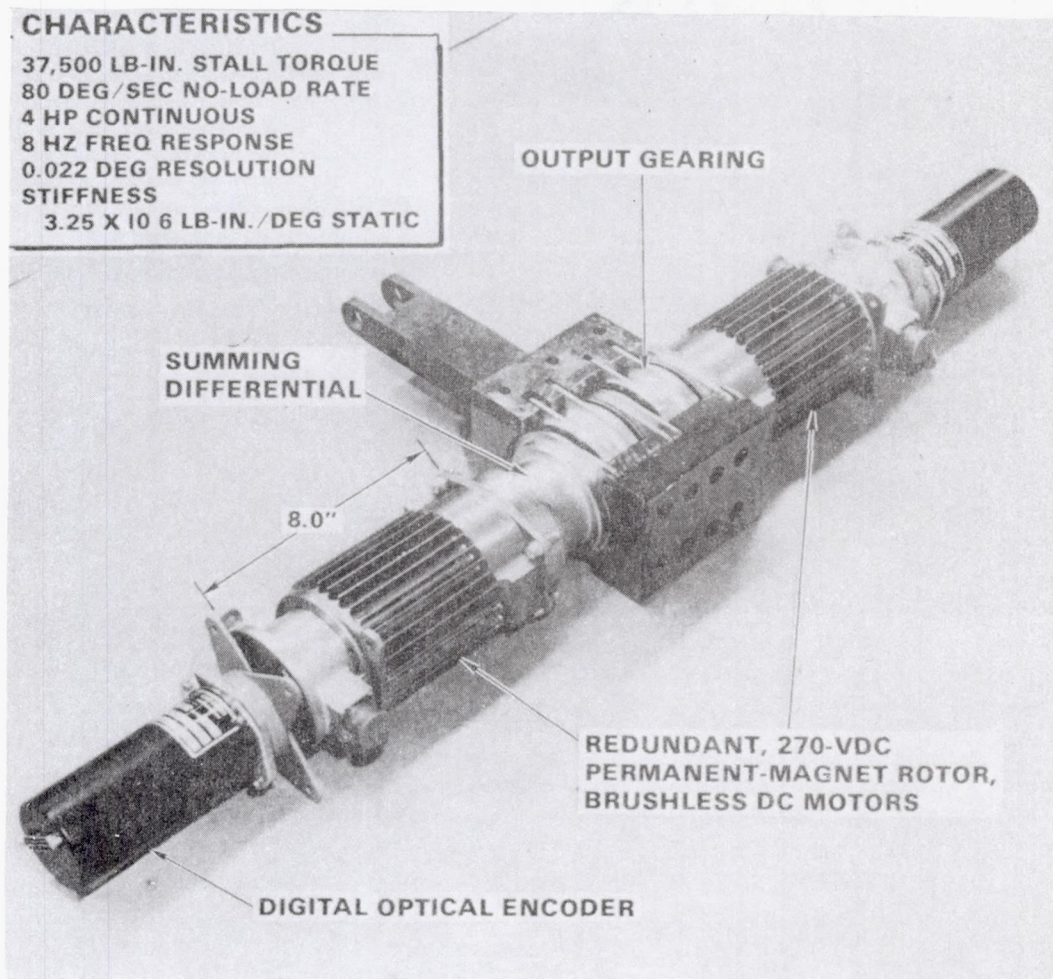

Figure 10. - EMA flight-configured hingeline actuator.

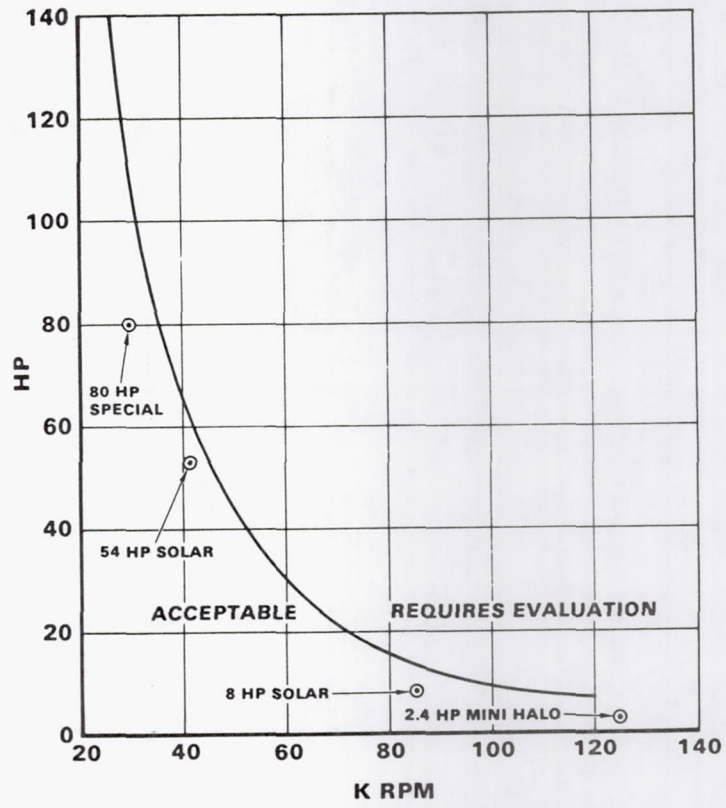

Figure 11. - Horsepower as a function of speed (radial magnet orientation).