

General Disclaimer

One or more of the Following Statements may affect this Document

- This document has been reproduced from the best copy furnished by the organizational source. It is being released in the interest of making available as much information as possible.
- This document may contain data, which exceeds the sheet parameters. It was furnished in this condition by the organizational source and is the best copy available.
- This document may contain tone-on-tone or color graphs, charts and/or pictures, which have been reproduced in black and white.
- This document is paginated as submitted by the original source.
- Portions of this document are not fully legible due to the historical nature of some of the material. However, it is the best reproduction available from the original submission.

Temp # 42357

NASA Technical Memorandum 83489

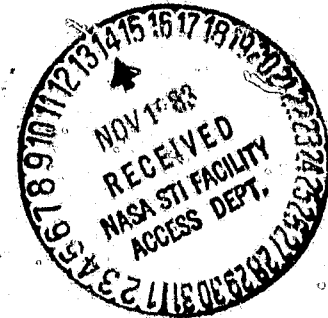

Resistojet Propulsion for Large Spacecraft Systems

(NASA-TM-83489) RESISTOJET PROPULSION FOR
LARGE SPACECRAFT SYSTEMS (NASA) 32 p
HC A03/MF A01 CSCL 21H

N84-11206

Unclas
G3/20 42357

Michael J. Mirsich
Lewis Research Center
Cleveland, Ohio

Presented at the
Sixteenth International Electric Propulsion Conference
cosponsored by the American Institute of Aeronautics and Astronautics,
the Japan Society for Aeronautical and Space Sciences,
and Deutsche Gesellschaft für Luft- und Raumfahrt
New Orleans, Louisiana, November 17-19, 1982



RESISTOJET PROPULSION FOR LARGE SPACECRAFT SYSTEMS

Michael J. Mirtich

National Aeronautics and Space Administration
Lewis Research Center
Cleveland, Ohio

SUMMARY

Resistojet propulsion systems have characteristics that are ideally suited for the on-orbit and primary propulsion requirements of Large Spacecraft Systems. These characteristics which offer advantages over other forms of propulsion are reviewed and presented. The feasibility of resistojets has been demonstrated in space whereas only a limited number of ground life tests have been performed. The major technology issues associated with these ground tests are evaluated. This paper also summarizes the past performance of resistojets, looks into the present day technology status and presents the material criteria, along with possible new concepts, needed to attain high performance resistojets in the near future.

INTRODUCTION

The on-orbit and primary propulsion requirements for Large Spacecraft Systems (LSS), will be more demanding than those of present day space satellites.

Resistojet propulsion systems have characteristics that are ideally suited for LSS. These characteristics include specific impulses (I_{sp}) greater than twice those obtainable with chemical propulsion and values of thrust-to-power ratio greater than four times that of ion propulsion. Resistojet propulsion systems also have extremely simple designs and interfaces when compared with alternate high performance propulsion concepts, as well as the ability to operate on many propellants, including products of biowaste systems, hydrogen, and space storables, such as ammonia.

Resistojets were demonstrated in space between 1965 and 1971 with 20 flights of over 50 thrusters, using N_2 , NH_3 and N_2H_4 propellants. Throughout the 1960's there was a strong technology program that was discontinued in the early 1970's, when efforts on the Manned Orbital Research Laboratory (MORL) were discontinued. A wide variety of propellants and a range of thrust levels varying from 0.045 to 6.5 newtons were demonstrated. Hence, the feasibility of the resistojet concept was shown. However, only a limited number of life tests were performed at the time. The major technology issues for resistojets were determined to be materials, heat transfer/fluid dynamics, and propellant management; these issues are reviewed and presented in this paper.

An evaluation of resistojet concepts has been initiated at LeRC with the objectives of providing on-board propulsion for manned and unmanned LSS. The efforts are broad in scope and include programs to establish mission requirements, identify focused technology objectives, and define performance potentials and constraints. Key technology efforts in the program include:

materials evaluation at high temperature in relevant propellant environments; design and testing of efficient rugged and reliable heat transfer concepts; evaluate all energy and propellant management concepts, and evaluation and control of effluents. This research and technology effort is germane in many aspects to other electrothermal propulsion concepts such as arc jet, free radical, laser, nuclear, and solar thermal propulsion.

This paper summarizes the past performance of resistojets, looks into the present day technology status and presents some of the material criteria, along with possible new concepts, needed to attain high performance resistojets in the near future.

LARGE SPACECRAFT SYSTEM (LSS) REQUIREMENTS

The on-orbit auxiliary and primary propulsion requirements for LSS will be more demanding than those of present day satellites. On-orbit propulsion for LSS must address the impacts of gravity gradient, aerodynamic and solar pressure caused forces and torques, which for LSS will result in propulsion requirements far more demanding than those of today's small, dense, spacecraft (refs. 1 to 5). As a consequence, propulsion system specific impulse will have significantly greater mission impact than in the past. Figures 1 to 4 show some examples of LSS requirements which imply significant benefits through the use of advanced resistojet propulsion systems.

Presented in figure 1 is the effect of solar pressure on geosynchronous stationkeeping mission velocity increment for LSS. The solar pressure effect is altitude insensitive and is specified by an opaque area to mass ratio in meters² per kilogram. From the figure it can be seen that low density systems have greater on-orbit requirements than those of high density systems.

A replot of figure 1 is shown in figure 2 where the ratio of the propellant mass to the final spacecraft mass (M_p/M_f) for an ammonia hydrogen resistojet with an I_{sp} of 406 sec is plotted as a function of the area to mass ratio (A/M). Figure 2 assumes a hardware mass of zero and is for a seven year N-S and E-W stationkeeping mission. Also shown in the figure for comparison sake are a monopropellant of $I_{sp} = 220$ sec and a bipropellant of $I_{sp} = 320$ sec. This figure not only shows the trends for futuristic LSS, but more obviously the large benefits to be gained by use of a high I_{sp} , ammonia resistojet for high area to mass large spacecraft systems.

The space station, considered by NASA for the 1990's, must also address the problem of aerodynamic drag. Shown in figure 3 is a plot of the drag on the Science and Applied Manned Space Platform (ref. 5) (SAMSP) as a function of altitude for various atmospheric density models that include dayside/solar maximum and the nightside solar minimum. These models are included to show the range in drag on the SAMSP (average area = 290 m²) and hence, the variability of the requirements. This variation in drag implies propulsion systems for LSS that are extremely flexible. Any proposed space station, like the Space Operations Center (SOC) (ref. 4), would show a similar variation in drag. As will be pointed out in the next section resistojets do fulfill this need for flexibility.

An important issue to be considered for a manned space station is that of propellant resupply. Shown in figure 4 is the propellant resupply weights

required for the MFSC/McDAC Space base (ref. 6), using various types of propellants such as mono-propellant, bipropellants, H-O, H₂ resistojet and a biowaste resistojet. This figure shows both the benefits of use of high I_{sp} resistojets and the major benefit on a manned station of the use of the residual gases of the environmental control and life support systems (EC/LSS) where no resupply is necessary.

RESISTOJET CONCEPT AND CHARACTERISTICS

Figure 5 is a schematic of a typical resistojet design concept. A propellant is progressively heated as it passes over an electrically heated, heat exchanger. The propellant as it nears the thruster exit approaches the maximum temperature in the heat exchanger. The hot propellant is then accelerated in a nozzle. Propulsion is thus obtained by a thermodynamic process. Very low thermal losses can be achieved through effective thermal insulation and regenerative flow passages making a resistojet a highly efficient thruster.

Listed in table 1 are the salient characteristics of resistojets. These characteristics include: multi (gaseous) propellant capability, the ability to operate at low thrust with thrust to power ratios less than 0.2, large operating range, capability to trade performance for lifetime, a small volume and mass, simplicity of design and simple interfaces, and specific impulses to 1000 sec. Shown in figure 6 is a test history envelope of resistojets run on various propellants over a range of propellant temperatures. The figure indicates the multipropellant capability of resistojets and the range of experimental specific impulses attained to date for a given propellant. This range in operating temperatures suggests performance/lifetime trades. Another important operational aspect of resistojets is that if the heater should fail, the gaseous propellant is still available for thrust at cold gas specific impulses (H₂ = 294 sec, N₂ = 80 sec, NH₃ = 110 sec, etc.). The figure also implies that resistojets can operate on propellants which are noncontaminating and nonreactive with space system elements, which should simplify integration with the Space Transportation System (STS). Resistojets have a characteristic thrust to power ratio that is less than 0.2. Plotted in figure 7 is the thrust to power ratio, in lb/kW, for various resistojet thrusters as a function of I_{sp} for different propellant gases. The solid symbols are experimental data and the open symbols theoretical upper limits for a particular gas assuming frozen flow conditions. The lowest thrust/power is for H₂ at specific impulses approaching 1000 seconds and the highest thrust/power is for what are considered biowaste gases (CH₄, CO₂, H₂O, N₂).

Figure 8 presents performance envelopes obtained with hydrogen, ammonia, and nitrogen propellants at various power/thrust ratios. These data were taken at TRW using the TRW high performance electrothermal hydrazine thruster (HIPEHT) (refs. 7 to 9). The figure shows the range of specific impulse that can be attained for a given propellant. This I_{sp} range could be expanded by a larger variation of the heater temperature (i.e., power), or by varying the injection pressure.

Figures 9 and 10 show the variation in thrust, for fixed design resistojets (refs. 7 and 10) that can be obtained by varying the injection pressure. The data in figure 9 were taken using the HIPEHT thruster at a heater temperature of 2090° C, using ammonia as the propellant. The data in figure 10 were

taken with a concentric cylinder design resistojet (ref. 10) using hydrogen as the propellant. The data of figures 9 and 10 show that for a fixed design resistojet the thrust can be throttled over a 5 to 1 range and the specific impulse can be varied from 100 to 900 depending on the propellant and gas temperature (figs. 6 and 8).

Another characteristic innate to resistojets includes small volume and mass. The resistojet thrusters life tested by Marquardt (ref. 11) for 8000 hr using H₂ and NH₃, shown in figure 11 are only 7.5 cm long and each one weighs only 0.27 kg (0.6 lb).

The small mass characteristic of resistojets is shown in figure 12 where the dry mass of a resistojet system and the resistojet thruster mass are plotted as a function of power. The solid curve in this figure was obtained by the use of the following relationship developed by D. Byers (ref. 12).

$$M_{RS} = (M_T + M_{ppu} + M_{TH}) (1 + S) \quad (1)$$

where:

M_{RS} = resistojet system dry mass

M_T = thruster mass = $0.7P^{0.65}$

P = power, kW

M_{ppu} = power processor mass =
 $2.5P^{3/4} + 1.8P^{1/2} + 0.1P + 3$

M_{TH} = thermal rejection mass
 (PPU = 88 percent efficient)
 = $4.2P$

S = 20 percent assumed allowance for structure, feed lines, etc.

The equations for M_{ppu} and M_{TH} were obtained from reference 13. The equation for M_T was derived by Byers from resistojet thruster data (refs. 11 and 14). Substituting for the values of M_T , M_{ppu} , M_{TH} , and S equation (1) becomes

$$M_{RS} = (4.3P + 2.5P^{3/4} + 0.7P^{0.65} + 1.8P^{1/2} + 3) 1.2 \quad (2)$$

and is plotted as the solid curve in figure 12. The magnitude of a resistojet system dry mass is shown in figure 12. At large power levels the resistojet system dry mass becomes linear since the thermal rejection mass term in equation (2) becomes dominant. If, however, the resistojet is designed such that a power processor is not needed, then equation (2) becomes

$$M_{RS} = M_T = 0.7P^{0.65} \quad (3)$$

The resistojet thruster mass of equation (3) is also shown in figure 12 and is such a small fraction of the LSS mass that it may be desirable, for some missions where reliability is of importance, to have more than one resistojet onboard and have resistojet redundancy.

A basic resistojet system design has no moving parts except for an on/off valve for the propellant. Once the design is fixed the resistojet can be used with a wide variety of propellants over a large range of thrust levels, or specific impulse range. In fact, a prime attribute of a resistojet system is the flexibility of a fixed resistojet design which facilitates in matching propulsion systems to mission and vehicle requirements. Resistojets have been shown to operate on many gaseous propellants (refs. 11, 15, and 17), that range from the residual (EC/LSS) gases (CO_2 , H_2O , CH_4 , H_2 , N_2), to storables (NH_3), to space transportation systems and orbit transfer vehicle (STS/OTV) propellants (H_2). Resistojets, unlike chemical propulsion, use only one propellant at a time. Hence, resistojet systems require only one feed line.

The electrical interface of a resistojet is also simple. Only one power supply at low voltage (28 V or less) is required for resistojets. Once the power level is known, the resistance of the heat exchanger is usually chosen to accommodate the bus voltage of the spacecraft. However, a power conditioner can be used, to allow the resistojet designer latitude in designing the heat exchanger to fit the mission needs (ruggedized, long life vs. high performance).

PREVIOUS WORK

Ground Technology Program - 1960's

Throughout the 1960's a large resistojet technology effort¹⁸⁻²⁵ was conducted. This early program was followed by a concentrated effort in the 1970's on the development of hydrazine electrothermal decomposition thrusters. The following will discuss some of the more prominent types of thrusters designed, fabricated and tested in the 1960's and 70's. Two survey papers in references 18 and 19 summarize most of the results of this work effort and contain many, invaluable references, most of which will not be included in the reference list of this paper. However, some of the data contained in these references will be reiterated for completeness.

Various types of thruster concepts were built in the 1960's. One of these thruster concepts is one employing a concentric tube electric resistance-heated three pass heat exchanger, designed by Marquardt (ref. 11), for use with H_2 and NH_3 . This thruster was modified by Marquardt (ref. 15) for use with CO_2 , CH_4 , and H_2O . Relative to a single tube resistojet the concentric-tube design has the advantages of high thermal efficiency for low power consumption and a final gas temperature close to maximum wall temperature, for high specific impulse. The NH_3 and H_2 resistojet thrusters used rhodium for the heating element and thioated platinum and platinum alloy for use with biowastes. The British Rocket Propulsion Establishment (ref. 26) developed with ARTCOR (refs. 27 and 28) a five pass concentric tube heat exchanger using H_2 at 2500 K. This thruster attained a thrust level of 0.65 N (150 mlb) using 3.2 kW of power.

Two nitrogen resistojets were developed by TRW (ref. 18) for the Vela-3 and Advanced Vela spacecraft. These resistojets were similar in concept, but different in configuration. The Vela-3 resistojet had a single tube flow passage and the Advanced Vela resistojet had a three tube flow passage.

In 1960 at NASA Lewis Research Center, Jack and Spiez (ref. 21) designed and built the laboratory model resistance-heated resistojet thruster shown in figure (ref. 13). This H₂ resistojet was designed to attain a thrust of 5 N with an I_{sp} = 1000 sec, using 30 kW of power. It attained an I_{sp} of 710 secs with an estimated thrust of 4.25 N. Ducati, et al. (ref. 25) built a 30 kW H₂ resistance-heated thruster and attained a thrust level in the laboratory of 6.5 N.

Another type of thruster design, is one that has a large thermal inertia. Electrical power is continuously supplied to the heat exchanger. The energy to heat the propellant is taken from the thermal capacity of the thruster mass. Thus, high duty cycles or continuous operation of this type thruster severely degrade the thruster temperature, and hence the specific impulse. General Electric built a thermal storage resistojet that used a swaged heater element. The heat exchanger through which the propellant flowed was annular. This thruster was flown in space in a Navy Satellite using NH₃ as a propellant. It attained a specific impulse of 230 sec and used 30 W of power.

A lightweight fast-heat-up resistojet was a thruster design using a heating element of minimum thermal capacity. The TRW vortex thruster (ref. 18) was based on this design concept for use on small spacecraft, where power needs were limited. This thruster was tested in the laboratory using N₂, NH₃, Freon, and several other propellants. Gas is introduced tangentially to a coiled bare wire, whose axis coincides with the nozzle. The cool layer of gas on the cavity wall results in very low heat losses without the need of thermal insulation. The thermal time response is about one second when the power and propellant flow are activated simultaneously for thrust.

Avco also built some fast-heatup thrusters that were flown on the ATS-series spacecraft using NH₃ as the propellant (ref. 29). The thrusters were of very simple construction: a single rhenium tube with an integral nozzle served as both the heater and heat exchanger. After three years in orbit aboard ATS-E, two of these thrusters were successfully operated.

Another type of resistojet design concept started in the 1960's was the hydrazine electrothermal decomposition thruster. TRW designed a nominal 25 mlb thruster that was heated by a swaged heater that was wrapped around and brazed to the cylindrical portions of the thrust chamber. This tubular heater element was the thermal source for the hydrazine decomposition. TRW (ref. 30) reported that several electrically-heated, thermal decomposition hydrazine thrusters were tested in the 5 to 70 mlb thrust range. With 5 W of input power, pulsed specific impulses of between 165 to 215 sec could be attained depending on the duty cycle.

Avco also developed an electrothermal decomposition thruster in the late 1960's that was flown on a Navy spacecraft in 1971 (ref. 31).

During this era a variety of propellants (refs. 18 and 19) (H₂, NH₃, N₂H₄, N₂, CH₄, CO₂) and a wide range of thrust levels (0.01 to 1.0 lb) were

demonstrated. However, only a few life tests (refs. 6, 11, 26, and 32) were conducted with mixed results. Only one lifetest lasted as long as 8000 hr. This lifetest was conducted with H₂ and NH₃ propellants using a concentric tube heat exchanger resistojet designed and tested at Marquardt (ref. 11). The six 10 mlb resistojets shown in figure 11 were simultaneously tested, four with NH₃ and two with H₂. A 50/50 duty cycle - one cycle per hour with the thrusters in two groups, two NH₃ and one H₂ thruster per group was used. Table II summarizes the results of this lifetest. The four NH₃ thrusters were cycled in excess of 8000 hr. Anomalies occurred with the H₂ thruster S-1 and S-2 which were attributed to experimental fabrication techniques and not associated with the hydrogen propellant. S-1 developed a leak and was left in the lifetest to obtain temperature data, however, thruster S-2 was removed from the lifetest after 1426 hr. B-2 was substituted for S-2 and successfully completed 6023 hr of operation with hydrogen at which time the lifetest was terminated with over 8000 hr of cyclic operation on the NH₃ thrusters.

Some very interesting conclusions were drawn from these lifetests. Considering the fact that these thrusters were experimental units, assembled without the benefit of any production tools, there were no changes in performance level for the four ammonia thrusters after 8000 hr of cyclic operation and for the one hydrogen thruster after 6023 hr of cyclic operation. The pre-test and post-test calibrations were in acceptable agreement. There was no discernable throat erosion or deposition. It was concluded that sublimation, erosion and deposition were not life determining factors using Rhenium for the heater element at 1900° C. The inner and outer element touching (which occurred infrequently) was attributed to creep (ref. 11). Metallographic examinations of the heating elements of the life tested thrusters showed an adverse temperature distribution, existed in the concentric tube heat exchanger. These adverse temperature distributions resulted in a lower efficiency and higher power consumption than for the same Isp in a thruster with a favorable distribution. It was felt by the authors of reference 11 that a contoured heating element would have provided a more favorable temperature distribution.

After this long term life test, Marquardt fabricated three "ruggedized" thrusters (ref. 32). Two thrusters were run with NH₃ and one with H₂. Two thrusters were subjected to, and passed environmental structural testing to specifications considered applicable to launch and space environmental considerations. The thrusters accrued 720 operating life test cycles in good condition, structurally integral and capable of indefinite further operation.

The manned orbiting research lab (MORL) and space station (ref. 24) studies indicated that resistojets offered great benefits to manned space stations. However, as the effort on MORL was discontinued and priorities for space research changed in the late 1960's the resistojet programs sponsored by the government were discontinued around 1971.

TECHNOLOGY PROGRAMS - MID 1970's to 1983

Electrothermal Hydrazine Thrusters

An electrothermal hydrazine thruster contains two major sections: a propellant decomposition chamber and a high temperature heat exchanger. Hydrazine is fed into the decomposition chamber where it is vaporized and

decomposed to produce a hot gas mixture of nitrogen, hydrogen, and ammonia at temperatures in the range of 871° to 982° C. In a conventional resistojet thruster the thermal energy of the gas is then converted to kinetic energy by expulsion through the nozzle. In an electrothermal hydrazine thruster, a heat exchanger is used to increase the gas to higher temperatures (2000° C). This allows a further increase in the specific impulse of approximately 30 to 40 percent.

In the mid to late 1970's concentrated efforts involving electrothermal hydrazine thrusters were started in the U.S.A., Germany, and Great Britain. In the U.S.A. Rocket Research Co., TRW, and Hughes Aircraft, started active programs involving electrothermal hydrazine thrusters (refs. 8, 9, 14, 30, and 36). In Germany, starting in 1978, an augmented electrothermal hydrazine thruster (AEHT) (ref. 37) program was started by the German Ministry for Research and Technology for fundamental research in the areas of thermochemistry, high temperature materials technology and nozzle theory. Beginning in 1974, British Aerospace carried out a program to investigate the design and operating principles of a Electrothermal Hydrazine Thruster (EHT) (ref. 38).

Rocket Research Company (RRC) is building electrothermal hydrazine thrusters for R.C.A. to be used for north/south stationkeeping on their G STAR, RDA, SATCOM, and Spacenet communication satellites. An artists drawing of this thruster is shown in figure 14. Two of these type of thrusters are currently on board the RCA SATCOM G satellite. The thruster has a specific impulse of 290 sec and is capable of thrust levels between 40 to 80 mlb. Shown conceptually in figure 15 is the radiation coupled augmentation heater element. The advantages of this heater concept is that the heater is not exposed to the fluid. Also, the wire size and coil spacing can be large. The major disadvantage is a large element to gas temperature difference.

The High Performance electrothermal hydrazine thruster (HiPEHT) developed by TRW for Ford Aerospace and Communications Company is operational on the Intelsat V spacecraft (ref. 8). The HiPEHT thruster configuration is shown conceptually in figure 16. The thruster contains two major sections: a propellant decomposition chamber and a high temperature vortex heat exchanger TRW has limited the heater element temperatures to about 2093° C to afford design margin. The thrust levels of HiPEHT range between 178 to 490 mN (40 to 110 mlb).

The Hughes Aircraft Hydrazine Electrothermally Augmented Thruster (HEAT) (ref. 36) concept involves integrating a zirconia ceramic augmentation heater to a standard hydrazine catalytic decomposition chamber. The incorporation of the catalytic decomposition chamber eliminates the need of the initial decomposition heaters used in other designs. The HEAT concept was successfully demonstrated in 1978 in a 63 hr test. It had a thrust level of 27 mlb, an Isp of 270 sec, and used 290 W of power.

The AEHT program in Germany, supported by the European Space Agency (ESA), contains a decomposition chamber and an electrically resistive heating element within a heat exchanger downstream of the decomposer. The details of this design are presented in reference 37. The design specifications of this thruster is to have a specific impulse greater than 300 sec and a thrust level between 50 to 200 mN (11 to 45 mlb). Its design mission life is 7 years with the total operating time of 200 hr at 200 mN and 800 hr at 50 mN.

Beginning in 1974, British Aerospace carried out under ESTEC a program to investigate the design and operating principles of the Electrothermal Hydrazine Thruster (EHT) (ref. 38). In phase B of this multiphase program six engineering model thrusters were built and of these four were tested. These tests provide the British with some useful performance data, but in each case problems were encountered, mainly with injectors fracturing or becoming contaminated which curtailed the test program before the scheduled tests were completed.

FLIGHT HISTORY

Resistojets have a strong flight history. Between 1965-1971 over 50 thrusters were flown on 20 spaceflights. A summary of this flight history is shown in table III along with the TRW hydrazine thrusters which are currently (1981-1983) being flown on Intelsat V and the RRC hydrazine thruster on the STATCOM G satellite. The typical propellant used on the space flight thrusters were nitrogen, ammonia and hydrazine.

Table IV lists the thrust level, specific impulse and required power for the flight resistojets listed in table III. The earlier resistojets were of the low thrust variety with power requirements of less than 100 W.

TECHNOLOGY ISSUES

The development of a reliable high performance resistojet system is a multifaceted, multidisciplined problem requiring the expertise of many contributors. This, of course, implies the involvement of many technical issues. Technology issues of basic importance to high performance resistojets include materials evaluation at high temperature in propellant environments, efficient heat transfer concepts, fluid physics and atomic phenomena, energy and propellant management and evaluation of background pressure effects during ground testing.

Thruster/Materials

Shown in figure 17 is a plot of the maximum specific impulse as a function of propellant temperature for H_2 and NH_3 for both equilibrium and frozen flow conditions (ref. 33). Large gains in resistojet propulsion performance (I_{sp}) can be attained if propellant temperature levels are increased beyond the temperature/performance levels attained during life-testing of H_2 and NH_3 resistojets (shown in the figure) in the late 1960's (ref. 17).

To attain high gas temperatures in resistojets it is necessary to design heat exchangers that have a high thermal efficiency. It is also important to attain gas temperatures that are at, or near the maximum heat exchanger temperature just as the propellant is about to enter the nozzle. To obtain high thermal efficiency and high gas temperature a concentric cylinder resistojet concept using rhenium as the heat exchanger material was designed by the R.J. Page Co (ref. 34). Four concentric cylinder resistojets are being designed for the thrust level, specific impulse, power and propellants shown in table V. These resistojet designs are similar to the resistojets run by the British (ref. 26) in the early 1970's. The design of the two 150 mlb thrusters indicate that the gas temperature at the throat of the nozzle are within 50° C of

the maximum tube temperature. This is made possible by the use of regenerative heating of the gas, high thermal efficiency and an auxiliary coil heater. In the high performance resistojets, if limited spacecraft power is available, the recovery of the dissociation and ionization losses is a technical issue to be solved.

A major issue that, at the moment, prevents resistojets from reaching the performance levels (i.e., high i_{sp}) presented in figure 17 is that of materials. This issue alone is the life determining factor in long life/high performance resistojets. There are many potential problems to be addressed and combinations thereof, some of which are the following: There must not be thermal expansion incompatibilities between the heater and the rest of the resistojets structure; there must be chemical compatibility of propellants and the chamber surfaces in order to resist the formation of reaction products with the propellant. Since resistojets can be used in a cyclic mode of operation, cyclic fatigue must be addressed. Other potential problems include grain growth in heaters and resistance stability of the heaters. Grain growth inhibition (ref. 11), creep, fatigue, shock resistance, sublimation and erosion rates, and resistance stability enhancement at high temperature/propellant environments must also be addressed. Materials that have extremely high melting points and thus are candidate heat exchanger material are refractory carbides, nitrides, borides, and oxides of hafnium, molybdenum, niobium, tantalum, titanium, tungsten and zirconium. These refractory compounds were exposed to a static hydrogen environment between 2481° and 2759° C for one hour (ref. 35). The results of these tests show that some of these compounds were stable in a hydrogen environment.

Materials used for electrical insulation within the resistojets must maintain its insulating integrity in high temperature reducing gas streams. In the past boron nitride was used for electrical insulation. However, significant materials advancements have occurred in the past decade in the use of high purity alumina for electrical insulation.

The propulsion needs of the Space Station⁴ and the availability of the EC/LSS gases (CO_2 , CH_4 , H_2O) indicate the need to develop a near term resistojets operating on biowaste propellants at propellant temperatures up to 1300° C (see fig. 6). These oxidizing, carbonizing gases at cyclic temperatures present another difficult set of materials problems. A heater material selection study for a biowaste resistojets suggests the use of noble metals (refs. 39 and 40).

POWER PROCESSOR

A degree of freedom that can be given to the resistojets designer to guarantee long life resistojets is the ability to power adapt, and not compromise the design of the thruster by having to incorporate voltage characteristics of the power system onboard the spacecraft. This necessitates the use of a custom designed power processor with the ability to provide low voltage, high current, A.C. power. The power processor to be used in this system is unique since flight resistojets in the past were designed to operate directly off spacecraft power. This custom designed power processor should be low weight, highly efficient, low cost, highly reliable and be able to provide for the power needs of various types of resistojets thrusters.

TRW has used a boost line voltage regulator that was inserted between the spacecraft power source and HiPEHT on the INTELSAT V satellites (ref. 8). By continuously adjusting input voltage during blowdown, the HiPEHT heat exchanger can be kept close to its maximum allowable operating temperature, and hence, maximum specific impulse.

Propellant Management

Propellant management is not a technical issue with storables (NH_3 , N_2 , etc.), but becomes a major issue when a non-storable such as H_2 is used at the propellant. Then cryogenic storage and zero gravity effects must be addressed. If hydrazine (N_2H_4) is the propellant, then the deleterious effects of the nonvolatile residuals (NVR) innate to hydrazine feed systems must be corrected to insure long resistojet lifetime. Propellant impurities are probably an issue with all propellants.

Vacuum Pressure Effects

Resistojet nozzles are small, they have low Reynolds numbers, and hence, boundary layer effects are large. It was shown in previous studies (ref. 26) that nozzle design predictions were not met in laboratory tests. It was also found that facility interactions (high background pressures during thruster operation) can lead to degraded performance levels (ref. 9).

Shown in figures 18(a) and (b), are the background pressure effects on the specific impulse for the lifetest thrusters shown in figure 11. This data was taken at Marquardt (ref. 17) Co., with the thrusters run on hydrogen and ammonia propellants. These tests show improved performance of the thruster as the background cell pressure is decreased. Nozzle performance peculiar to flows at low Reynolds number, account for the improvement of the thruster at low cell pressures. Test cell flow recirculation effects were also found, during the Marquardt tests, to be influential in the measurement of thrust.

These background pressure effects will have to be addressed and evaluated in order to obtain realistic thruster data.

Long Life-Ruggedized High Performance Resistojet Concept

It might be possible to drastically reduce or eliminate the need for thermal insulation and heater material/propellant compatibility problems through the use of the porous media, multipass heat exchanger concept shown in figure 19. This concept conceived by Mirtich, Sovey, Zavesky, Byers, and Marinos, of Lewis, uses a textured, high emissivity heater element that radiatively transfers heat to the inner wall of the hollow cylinder, that is ion beam morphologically controlled for high absorptivity. This, in turn, raises the temperature of the particles, that are sized to allow efficient gas-particle heat transfer and not be clogged by the impurities of the propellant. A major advantage of this system is increased lifetime, for the heater is not exposed to the propellant flows. The use of porous materials makes this heat exchanger very efficient and extremely rugged, whose fabrication does not depend on close tolerances, thus implying a very inexpensive device.

CONCLUSIONS

The on-orbit auxiliary and primary propulsion requirements for large spacecraft systems will be more demanding than those of present day satellites. Significant benefits can be gained through the use of advanced resistojet propulsion systems. The use of residual gases of the environmental control and life support system (EC/LSS) eliminates the need of propellant resupply associated with mono or bipropellant systems.

Resistojets have characteristics that include: simplicity of design and interfaces, low thrust to power ratios, multi (gaseous) propellant capability, the capability to trade performance for lifetime, small volume and mass, and large operating envelopes.

The resistojet concept has been demonstrated. Resistojets have a strong ground program and a successful flight history (25 flights to date). A large resistojet technology effort throughout the 1960's was sponsored by NASA, DOD, and industry. This early effort was followed by a concentrated program in the 1970's on the development of hydrazine electrothermal decomposition thrusters. The hydrazine thruster development has led to the use of these thrusters for N/S stationkeeping on Intelsat V and SATCOM G communication satellites.

Technology issues of basic importance to the development of long life/high performance resistojets include: material evaluation at high temperature in propellant environments, efficient heat transfer concepts, propellant management when nonstorables are used as the propellant and the need to evaluate the effects of background pressure during ground testing.

REFERENCES

1. Smith, W. W. and Clark, J. P., "Study of Electrical and Chemical Propulsion Systems for Auxiliary Propulsion of Large Space Systems" - Boeing Aerospace Company, Seattle, Wash., D180-25956-3-VOL-1, Nov. 1981. (NASA CR-165502-VOL-1.)
2. "Large Space Systems/Low-Thrust Propulsion Technology," NASA CP-2144, July 1980.
3. Maloy, J., Smith, W. W., and Machles, G. W., "Auxiliary Propulsion Requirements for Large Spacecraft Structures," NASA TM-83388, June 1983.
4. "Space Operations Center (SOC) System Analysis Study Extension," Boeing Aerospace Research, Seattle, Wash., D180-26785, Jan. 1982. (NASA CR-167555.)
5. "Evolutionary Space Science Concept Study," McDonnell-Douglas Astronautics Company, Huntington Beach, Calif., MDC-H0072, May 1982. (NASA CR-170829)
6. Pisciotta, A., "Report on The Development of the Manned Orbiting Research Laboratory, MORL System Improvement Study," Douglas Aircraft Co., Santa Monica, Calif., SM-48819B, Jan. 1966.

7. Zafran, S. and Jackson, B., "Electrothermal Thruster Diagnostics," TRS Defense and Space Systems group, Redondo Beach, Calif., TRW-39152-6011-UE-00, 1983. (NASA CR-168174)
8. Zafran, S., Murch, C. K., and Grabbi, R., "Flight Applications of High Performance Electrothermal Thrusters," AIAA Paper 77-965, July 1977.
9. Sackheim, R. L., Fritz, D. E., and Macklis, H., "The Next Generation of Spacecraft Propulsion Systems," AIAA Paper 79-1301, June 1979.
10. Donovan, J. A., and Lord, W. T., "Performance Testing of a 3Kw Hydrogen Resistojet," Electric Propulsion of Space Vehicles, IEE Conference Publication, No. 100, Institution of Electrical Engineers, 1973, pp. 151-155.
11. Yoshida, R. Y., Halbach, C. R. and Hill, C. S., "Life Test Summary and High Vacuum Tests of 10 mlb Resistojets," AIAA Paper 70-1136, Apr. 1970.
12. Byers, D., "Private Communication," Feb. 1983.
13. Byers, D., "Characteristics of Primary Electric Propulsion Systems," NASA TM-79255, Oct. 1979.
14. Dressler, G. A., Morningstar, R. E., Sackheim, R. L., Fritz, D., and Kelso, R., "Flight Qualification of the Augmented Electrothermal Hydrazine Thruster," AIAA Paper 81-1410, July 1981.
15. Halbach, C. R., "10 mlb Biowaste Resistojet Performance," AIAA Paper 71-687, June 1971.
16. Page, R. J., and Short, R. A., and Greco, R. V., "Definition of a Resistojet Control System for the Manned Orbital Research Laboratory" Volume V, Douglas Aircraft Co., Van Nuys, Calif., DAC-58134, May 1968. (NASA CR-66604).
17. Yoshida, R. Y., Halbach, C. R., Page, R. J., Short, R. A., and Hill, C. S., "Resistojet Thruster Life Tests and High Vacuum Performance," Marquardt Corp., Van Nuys, Calif., TMC-S-974, July, 1970. (NASA CR-66970.)
18. Greco, R. V., Bliss, J. R., Murch, C. K., Clark, K. E., and Kelly, A. J., "Resistojet and Plasma Propulsion System Technology," AIAA Paper 72-1124, Nov. 1972.
19. Finke, R. C., and Murch, C. K., "Current Technology in Ion and Electrothermal Propulsion," AIAA Paper 73-1253, Nov. 1973.
20. Jack, J. R., "Theoretical Performance of Propellants Suitable for Electrothermal Jet Engines," NASA TN D-682, Apr. 1961.
21. Jack, J. R., and Spisz, E. W., "NASA Research on Resistance-Heated Hydrogen Jets," AIAA Paper 63023-63, Mar. 1963.
22. Jack, J. R., "Regenerative and Radiation Cooling of Electrothermal Thrust Generators. Preprint 61-97-1791, American Rocket Society, June 1961.

23. Page, R. J., Short, R. A., and Greco, R. V., "Definition of a Resistojet Control System for the Manned Orbital Research Laboratory," Final Report, Volumes I-V, Douglas Aircraft Co., Huntington Beach, Calif., DAC-58134, May 1968. (NASA CR-66604).
24. "Space Station Executive Summary," McDonnell-Douglas Astronautics Co., Huntington Beach, Calif., MDC-G2727, Apr. 1972 (NASA CR-123719); "Space Station (Modular) Mission Analysis, Vol. 1, Mission Analysis," MDC-G2684-Vol-1, Nov. 1971 (NASA CR-121077); Vol. 2, Appendix, MDC-2684-Vol-2, Nov. 1971 (NASA CR-121078).
25. Ducati, A. C., Muehlberger, E., and Todd, J. P., "Resistance Heated Thruster Research," Giamini Scientific Corporation, Santa Ana, Calif., Technical Report AFAPL-TR-65-71, July 1965. (AD-469203)
26. Donovan, J. A., Lord, W. T., and Sherwood, P. J., "Fabrication and Preliminary Testing of a 3Kw Hydrogen Resistojet," AIAA Paper 72-449, Apr. 1972.
27. Page, R. J., Halbach, C. R., Short, R. A., "3Kw Concentric Tubular Resistojet Performance," Journal of Spacecraft and Rockets, Vol. 3, No. 11, Nov. 1966, pp. 1669-1674.
28. Page, R. J., Short, R. A., "Design of High Performance Resistojet for Advanced Spacecraft," AIAA Paper 71-195, Jan. 1971.
29. Pugmire, T. K., and Davis, W. S., "ATS-III Resistojet Thruster System Performance," Journal of Spacecraft and Rockets, Vol. 6, No. 7, July 1969, pp. 790-794.
30. Murch, C. K., and Hunter, C. R., "Electrothermal Hydrazine Thruster Development," AIAA Paper 72-451, Apr. 1972.
31. Enos, G. R., Pugmire, T. K., and Shaw, R., "Applied Resistojet Technology," AIAA Paper 70-211, Jan. 1971.
32. Pfeifer, G. R., "Technology Development and Demonstration of a Low Thrust Resistojet Thruster," Marquardt Company, Van Nuys, Calif., NASA CR-112160, July 1972.
33. Schaefer, J. W., and Feranti, J., "Analytical Evaluation of Possible Noncryogenic Propellants for Electrothermal Thrusters," NASA TN D-2253, Mar. 1964.
34. Page, R. J., and Stone, W. A., "The Design and Technology Development for a 150 mlb Resistojet for H₂ or NH₃," AIAA Paper 82-1949, Nov. 1982.
35. May, C. E., and Hoskstra, P. D., "Stability of Refractory Compounds in Hydrogen between 4500°F. and 5000°F. and their Compatibility with Tungsten," NASA TN D-844, May 1961.
36. Finston, R., Meese, R. A., "Hydrazine Electrothermally Augmented Thruster (HEAT), AIAA Paper 79-1332, June 1979.

37. Schmitz, H. D., and Steenborg, M., "Augmented Electrothermal Hydrazine Thruster (AEHT) Development," AIAA Paper 81-1409, July 1981.
38. Taylor, C. B., "Electrothermal Hydrazine Thruster," British Aerospace Dynamics group, Stevenage, England, BAE-RPT/EHT/40212-VOL-1, 1981.
39. Halbach, C. R., and Yoshida, R. Y., "Development of a Biowaste Resistojet," Journal of Spacecraft and Rockets, Vol. 8, No. 3, Mar. 1971, pp. 273-277.
40. Halbach, C. R., Page, R. J., McCaughley, O. J., and Short, R. A., "Investigation of Biowaste Resistojets for Space Station Application," Advanced Rocket Technology, Irvine, Calif., NASA CR-112159, July 1972.

TABLE I. - RESISTOJET PROPULSION
CHARACTERISTICS

o	Multi (gaseous) propellant capability
o	Low thrust $\frac{T(\text{lb})}{P(\text{kw})} \leq 0.25$
o	Large operating envelope
o	Performance/lifetime trade available
o	Small volume and mass
o	Simplicity of design and simple interfaces
o	Specific impulses to ≈ 1000 seconds

TABLE II. - SPACE PROPULSION DIVISION

[Marquardt lite test thrusters]

Thruster serial no.	S-1	S-2	B-2	S-3	S-4	S-5	S-6
Propellant	H ₂	H ₂	H ₂	NH ₃	NH ₃	NH ₃	NH ₃
Test duration, hr	7858	1426	6023	8048	8152	8052	8134
I _{sp} , sec	660	670	670	320	320	320	320
Electric power, W	258	220	222	131	189	145	145
Thrust, mlb	11.7	10.0	10.5	9.2	11.9	10.6	10.5

TABLE III. - RESISTOJET FLIGHT HISTORY

Spacecraft	First flight	Total flights	Propellant	Manufacturer	Function
Vela	1965	2	N ₂	TRW	Orbit adjustment
Advanced Vela	1967	4	N ₂	TRW	Orbit adjust/ attitude control
Navy satellite	1965	5	NH ₃	GE	Attitude control and orbit control
ATS-A,C	1966	2	NH ₃	AVCO	Experiment
ATS-D,E	1968	2	NH ₃	AVCO	Attitude control
Navy satellite	1971	4	NH ₃	AVCO	Operational system
Navy satellite	1971	1	N ₂ H ₄	AVCO	Experiment
INTELSAT V	1981	4	N ₂ H ₄	TRW	N/S station keeping
Flights (1-4) RCA SATCOM G	1983	1	N ₂ H ₄	RRC	N/S station keeping

TABLE IV. - OPERATING CONDITIONS AND RESULTS OF FLIGHT TESTS

Spacecraft	Thrust, mlb	Isp, sec	Power, W	Comment
Vela	42	123	92	First operational resistojets. No failures
Advanced Vela	20	132	30	Two 3 nozzle thrusters per spacecraft. No failures
Navy satellite problems	20	230	30	Flight systems encountered some valve leakage
ATS-II, III	4	150	3.6	ATS-A system failed, ATS-C system was partial success
ATS, IV, V	4	150	3.6	Both systems successful. D system successfully activated after 3 years in orbit
Navy satellite	10-80	235	3	Unsuccessful orbital demonstration
INTELSAT V	50-110	280	(300-660)	Successful flight operation
SATCOM G	40-30	295	450	On board

TABLE V. - ELECTROTHERMAL PROPULSION
RESISTOJETS CONCENTRIC CYLINDER DESIGNS

	Thrust, mlb	Specific impulse, sec	Power, kW	Propellant
(1)	150	828	3.5	H ₂
(2)	150	406	2.1	NH ₃
(3)	10	757	.27	H ₂
(4)	10	375	.17	NH ₃

ORIGINAL PAGE IS
OF POOR QUALITY

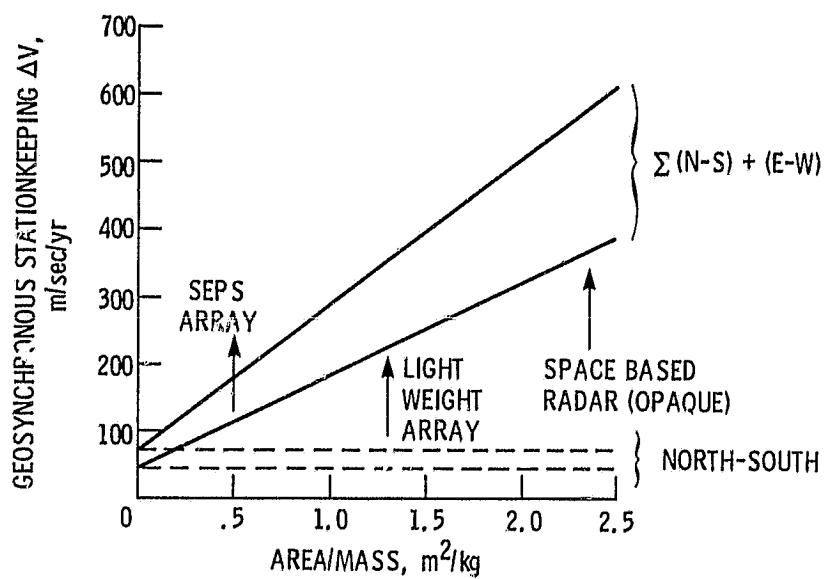

Figure 1. - Effect of solar pressure on LSS.

ORIGINAL PAGE IS
OF POOR QUALITY

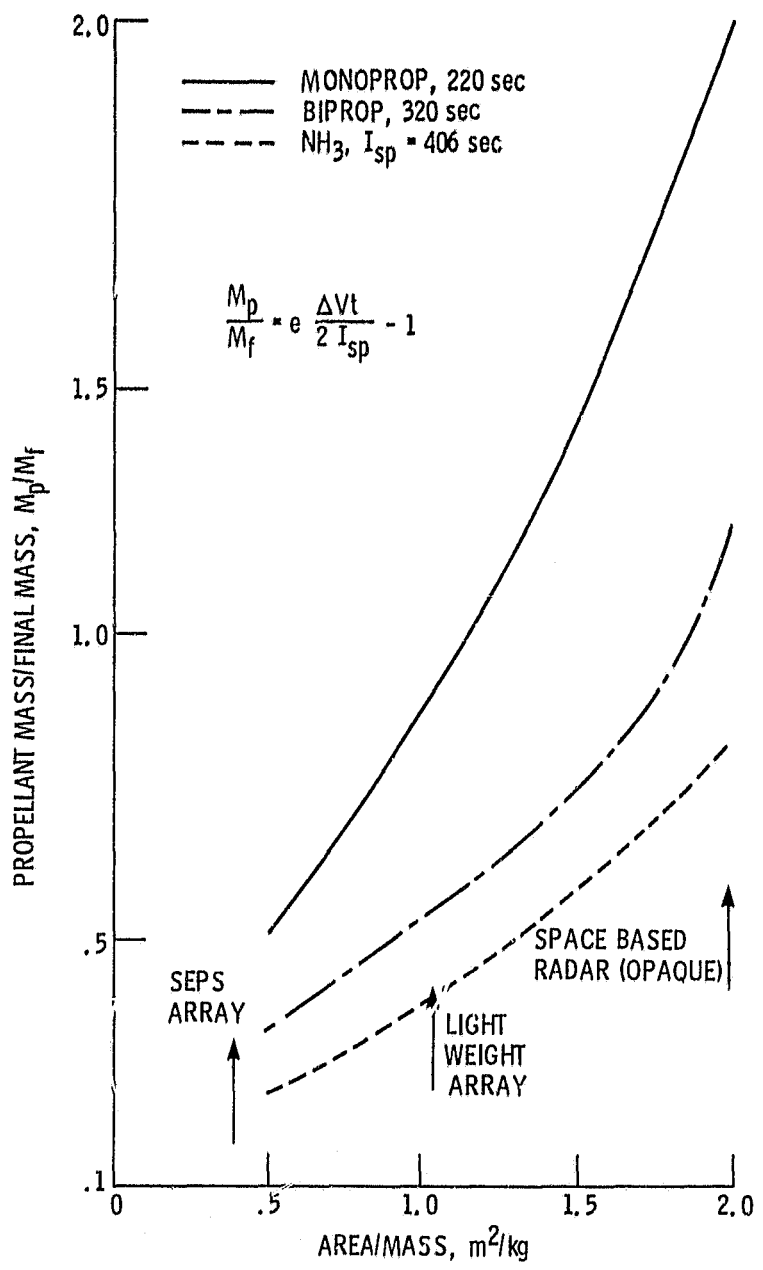

Figure 2. - Ratio of propellant mass to final mass versus area to mass ratio for H₂ resistojet and bipropellants assumes a hardware mass of zero.

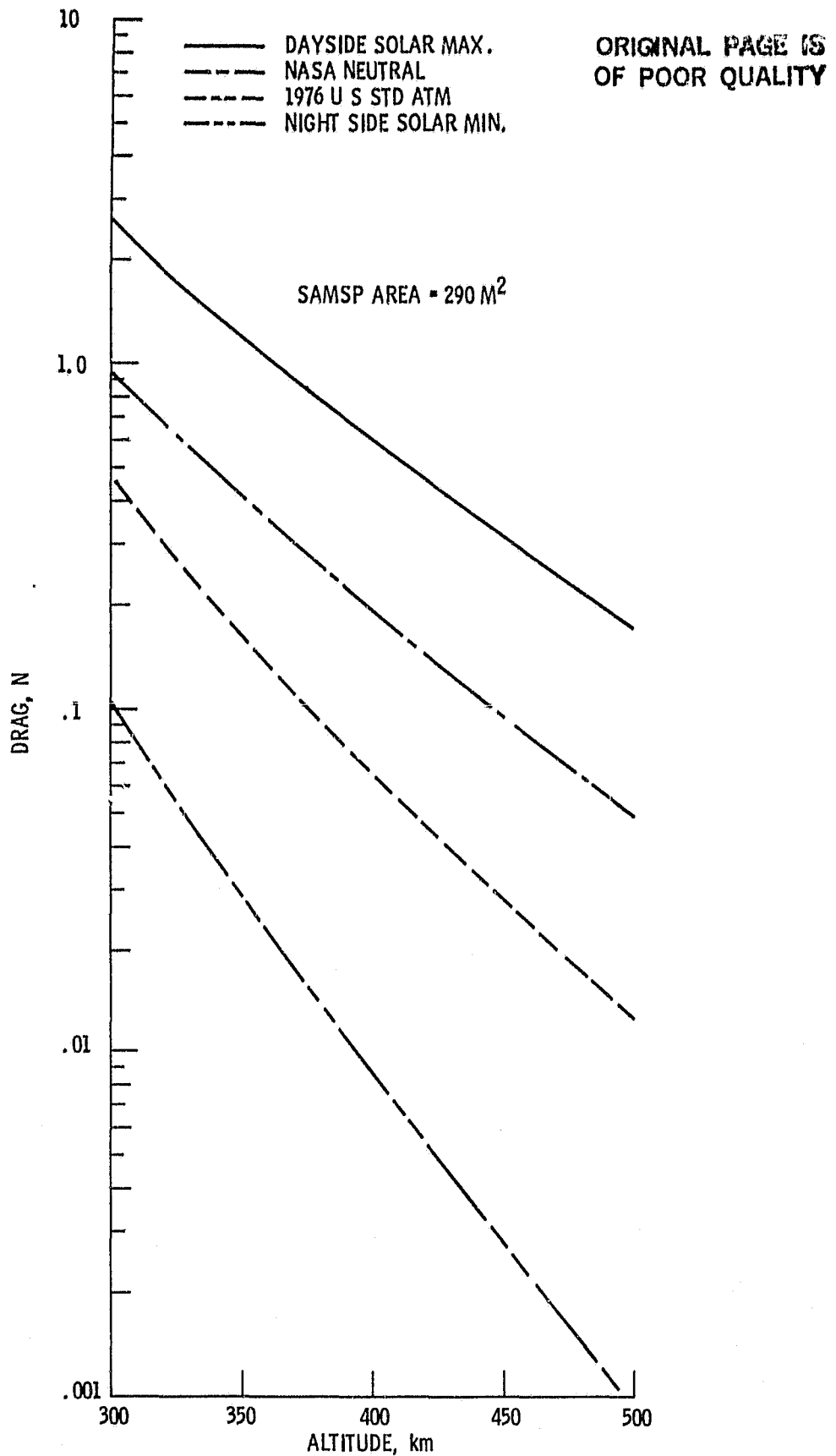

Figure 3. - Drag on the science and applied manned space platform (SAMSP) as a function of altitude for various atmospheric density models.

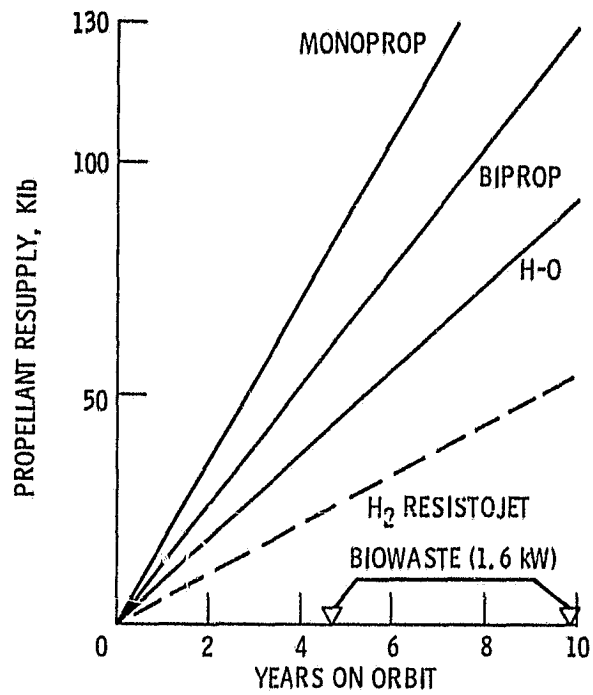

Figure 4. - MFSC/McDAC space base propellant resupply.

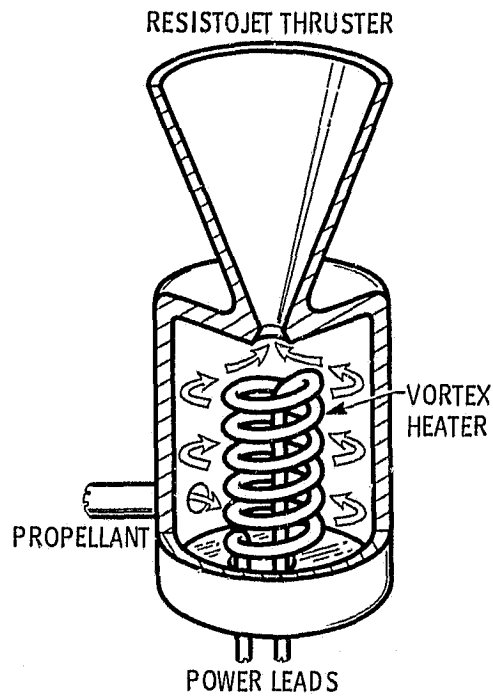

Figure 5. - Typical resistojet design concept.

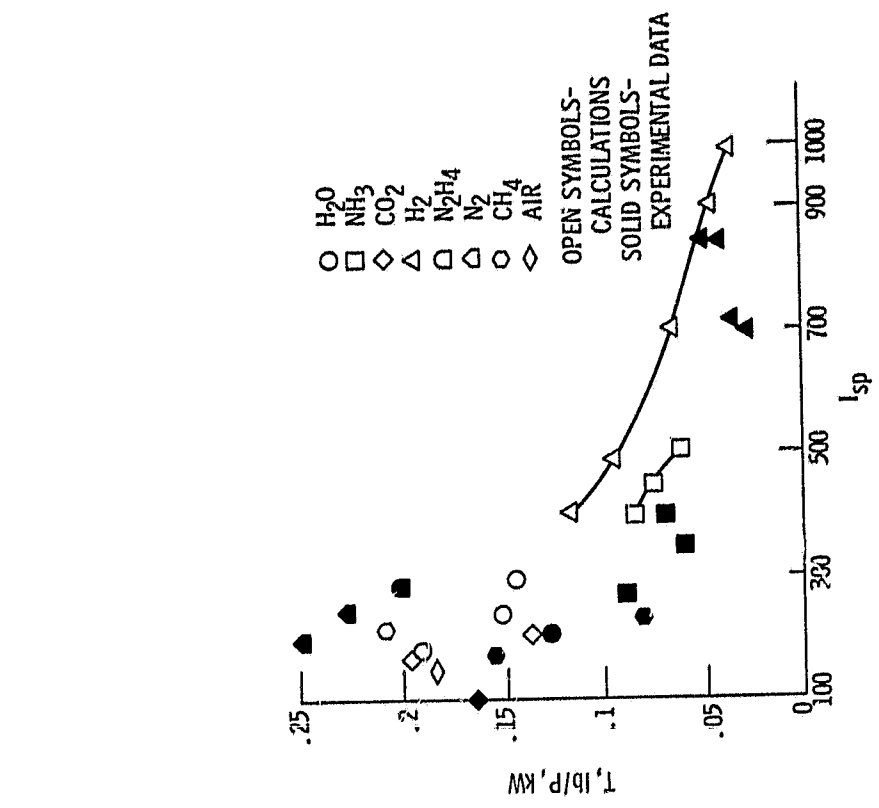

Figure 7. - Thrust to power ratio for various resistojet thrusters as a function of I_{sp} for different propellant gases.

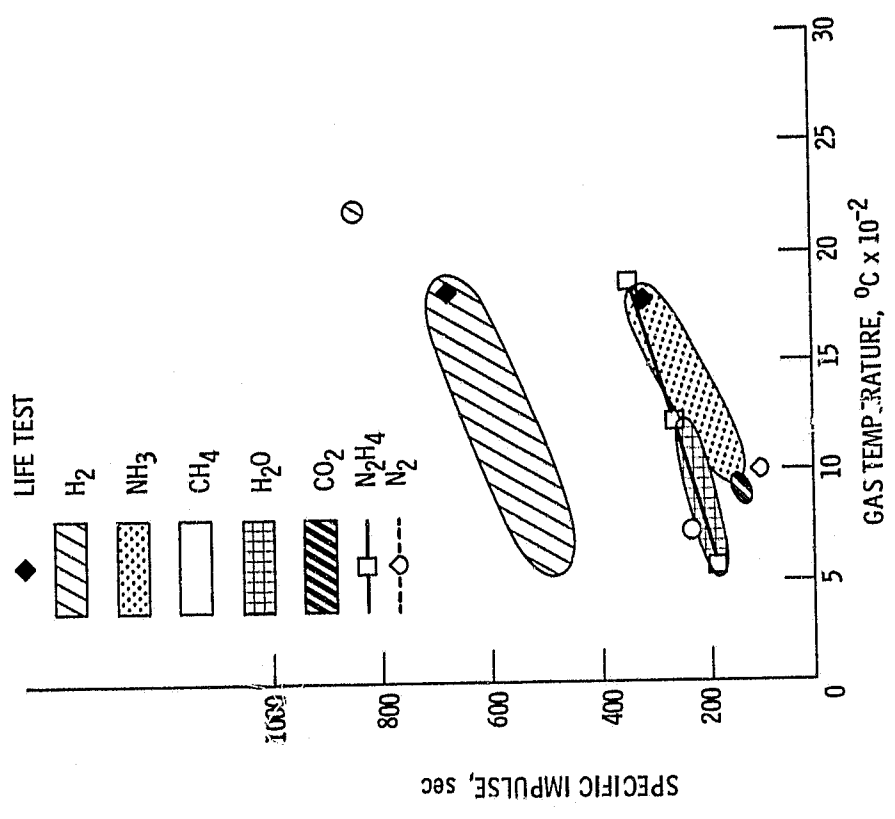

Figure 6. - Resistojet test history, indicating the multipropellant capability of resistojets and the range of experimental specific impulses attained to date for a given propellant.

ORIGINAL PAGE IS
OF POOR QUALITY

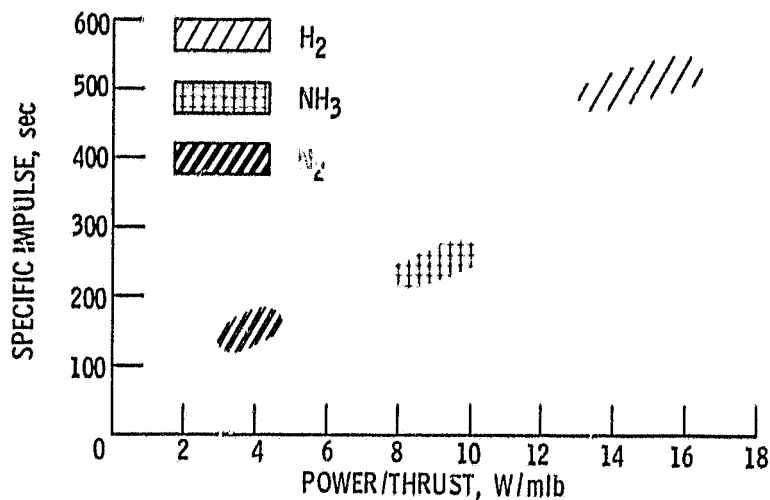

Figure 8. - Performance envelopes obtained with hydrogen, ammonia, and nitrogen gases at various power to thrust ratios. TRW DATA.

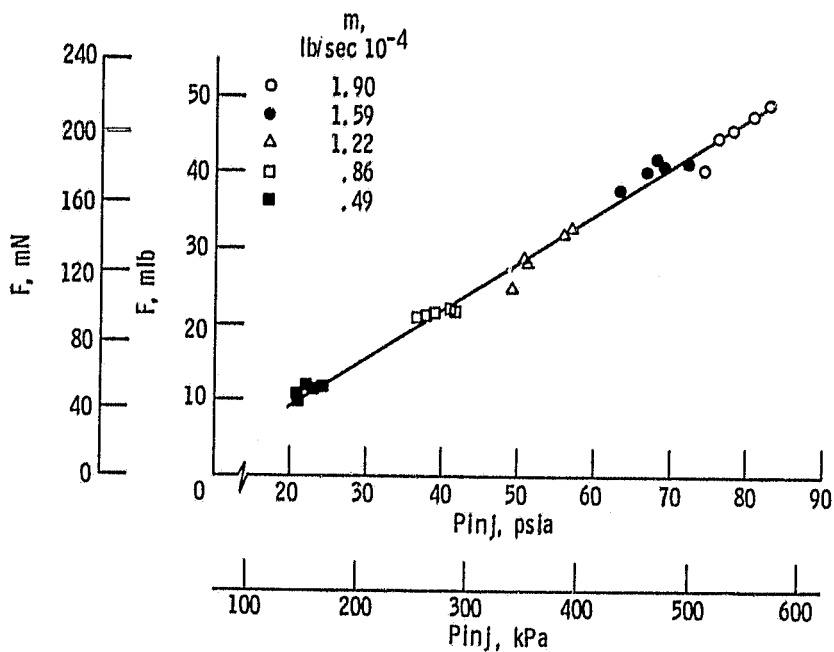

Figure 9. - Thrust versus injection pressure, ammonia propellant, for a heater temperature of 2090° C, using the HIPEHT thruster.

ORIGINAL PAGE IS
OF POOR QUALITY

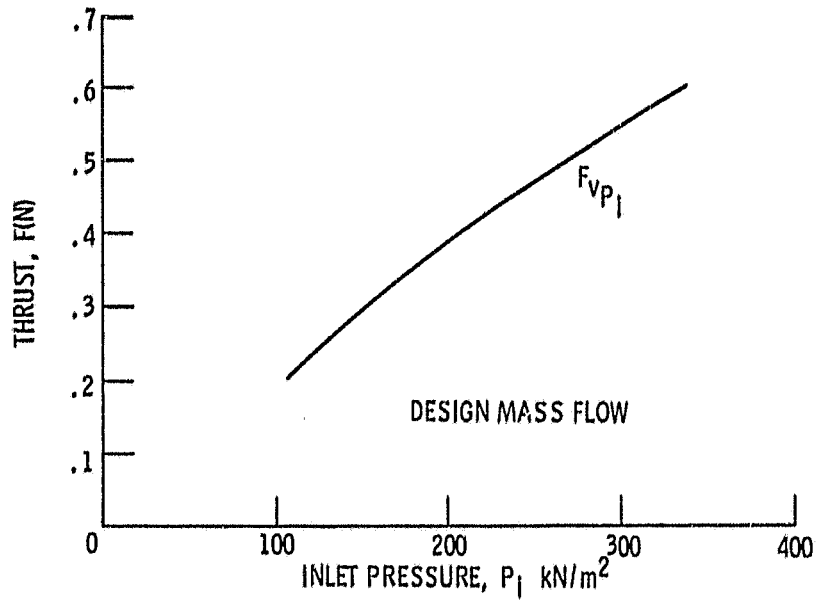
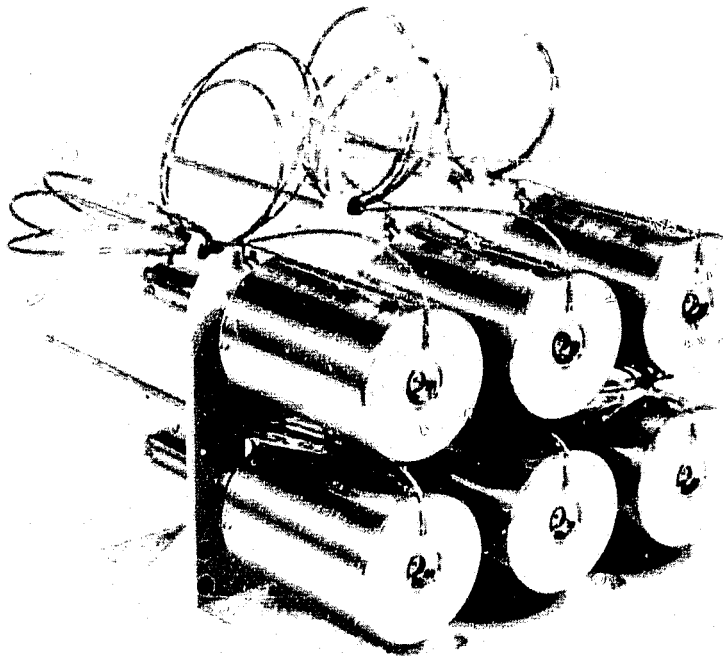

Figure 10. - Thrust versus inlet pressure for a concentric cylinder resistojet using a hydrogen propellant.



C-82-1061

Figure 11. - Resistojet thrusters life tested by marquarot for 8000 hr.

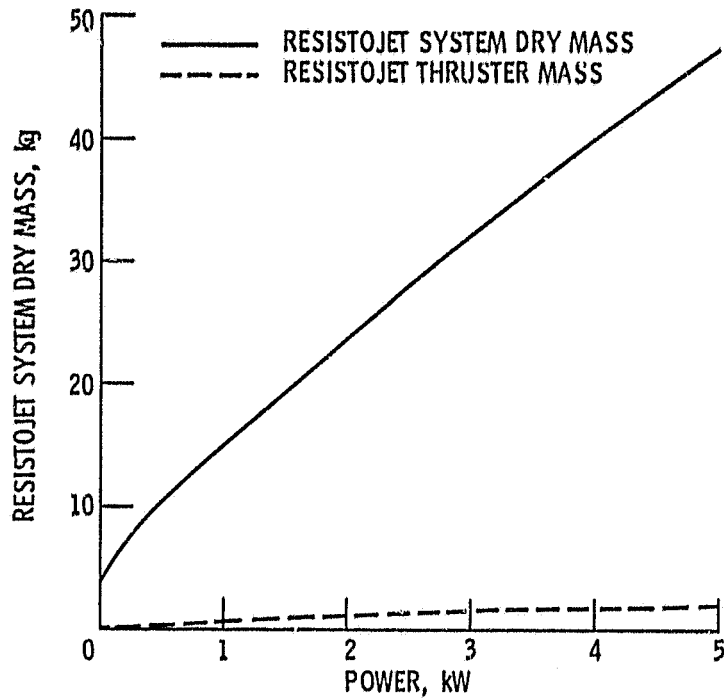

Figure 12. - Resistojet system dry mass and thruster mass as a function of power.

ENGINE DIMENSIONS

HEAT EXCHANGER; LENGTH, 5 in.
INSIDE DIAMETER, 1 in.
NOMINAL THICKNESS, 0.03 in.
NOZZLE THROAT DIAMETER, 0.21 in.
OVERALL; LENGTH, 17 in.
DIAMETER, 4 in.

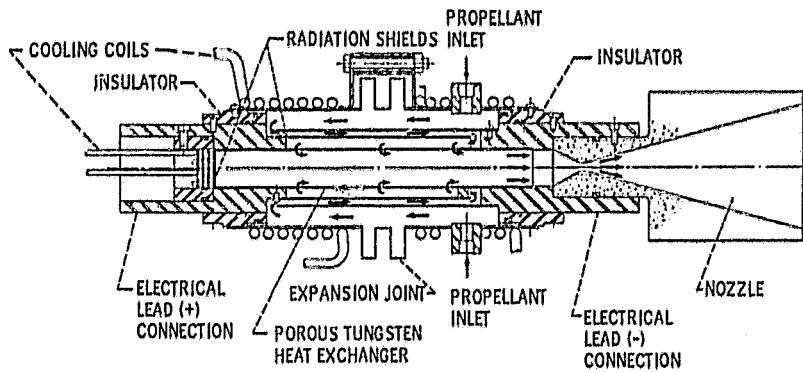

Figure 13. - Jack and Splisz resistance-heated hydrogen engine.

ORIGINAL PAGE IS
OF POOR QUALITY

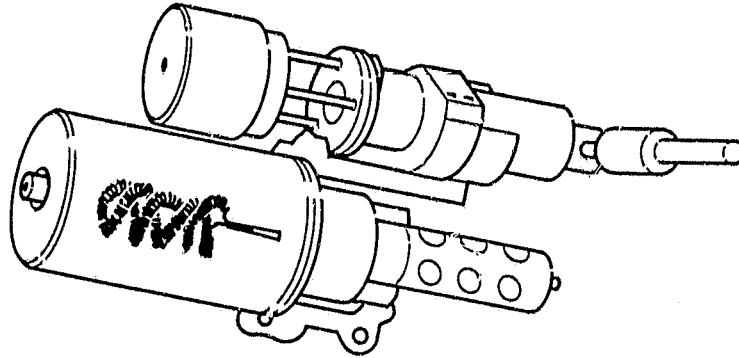
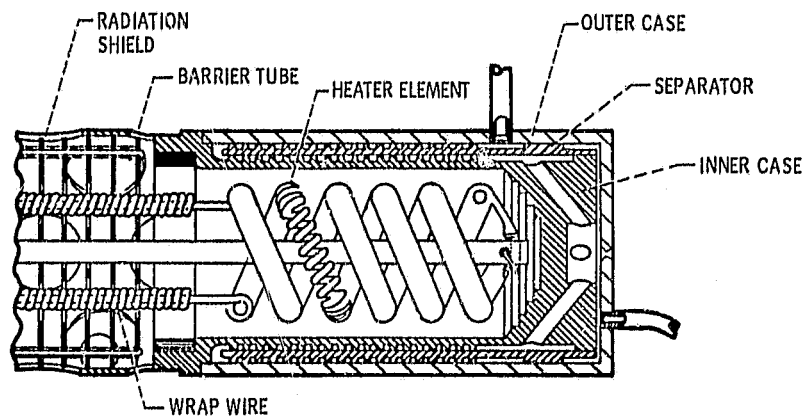

Figure 14. - Artists drawing of the Rocket Research Company (RRC) electrothermal hydrazine thruster.



ADVANTAGES

HEATER ELEMENT IS NOT
EXPOSED TO FLUID
WIRE SIZE AND COIL SPACING
CAN BE LARGE

DISADVANTAGES

LARGE ELEMENT TO GAS ΔT
WIRE ELEMENTS MUST BE SUPPORTED
LARGE PHYSICAL SIZE

Figure 15. - Shown conceptually is the radiation coupled augmentation heater element for the RRC thruster.

ORIGINAL PAGE IS
OF POOR QUALITY

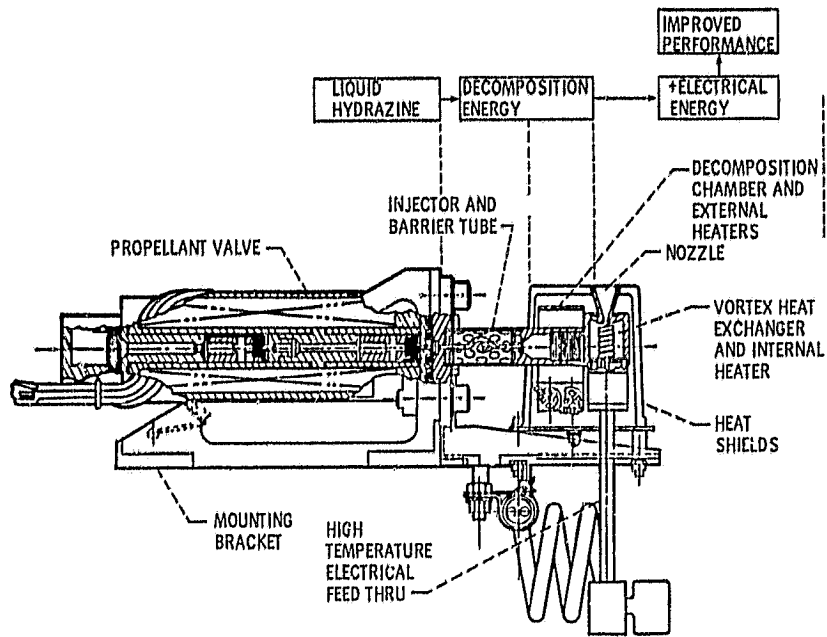

Figure 16. - HIPEHT concept and flight thruster configuration.

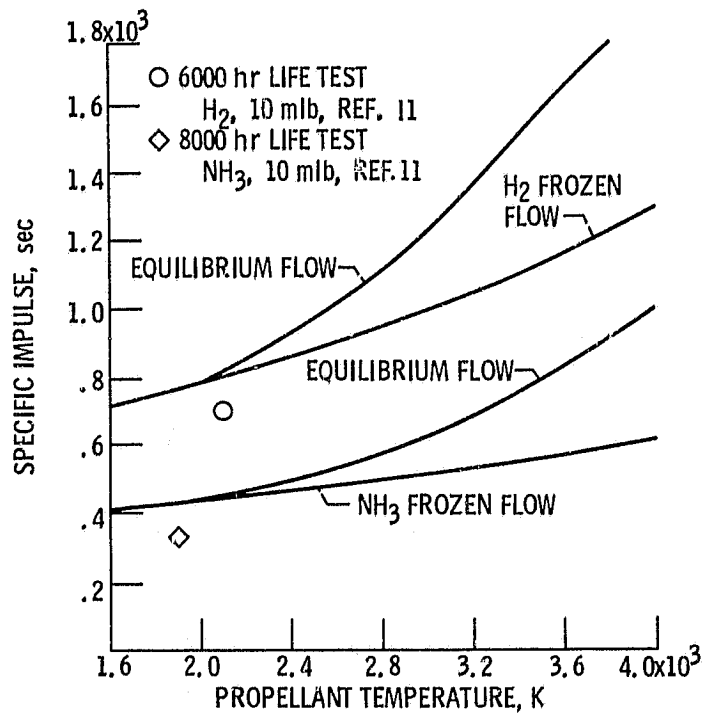

Figure 17. - Plot of specific impulse as a function of propellant temperature.

B-2 THRUSTER
M₂ FLOW = 0.00690 g/sec
POWER = 220 W
CELL PRESSURE VARIED WITH H₂
MAY 26, 1970
RUN 30

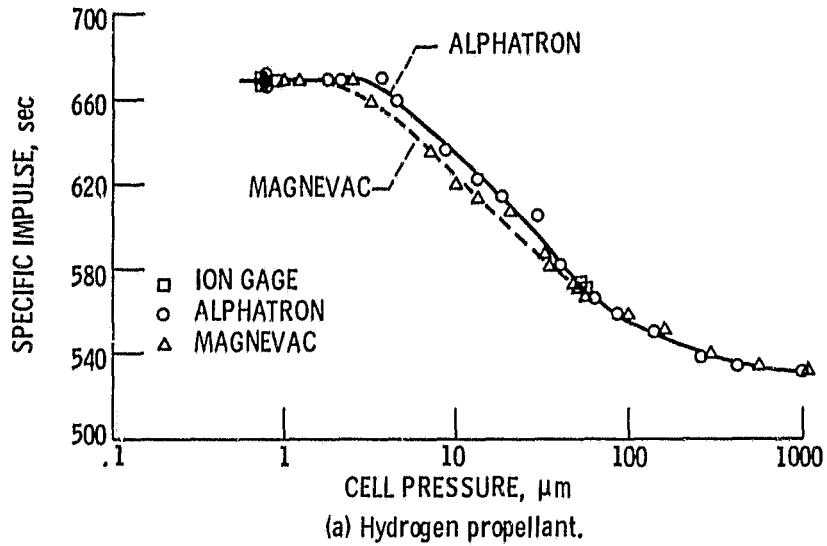

Figure 18. - Background pressure effect. Data taken at Marquardt.

B-2 THRUSTER
NH₃ FLOW = 0.0140 g/sec
POWER = 140 W
MAY 25, 1970
RUN 29

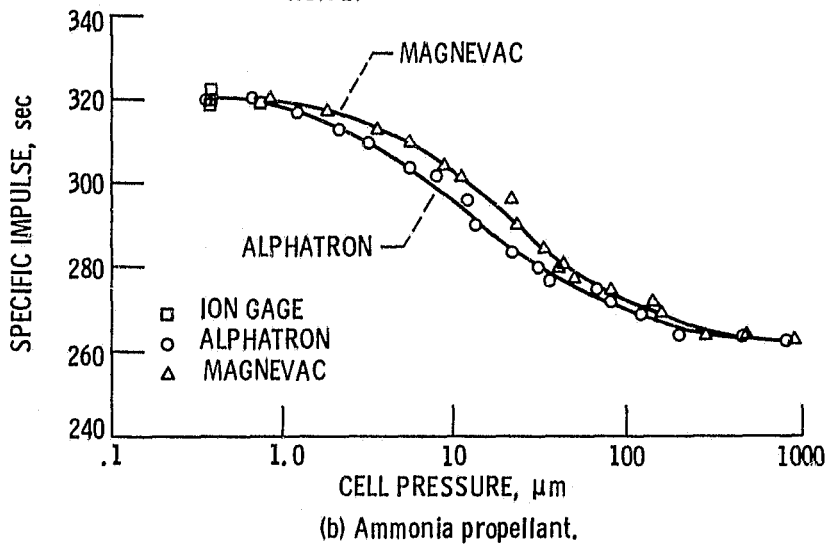

Figure 18. - Concluded.

ORIGINAL PAGE IS
OF POOR QUALITY.

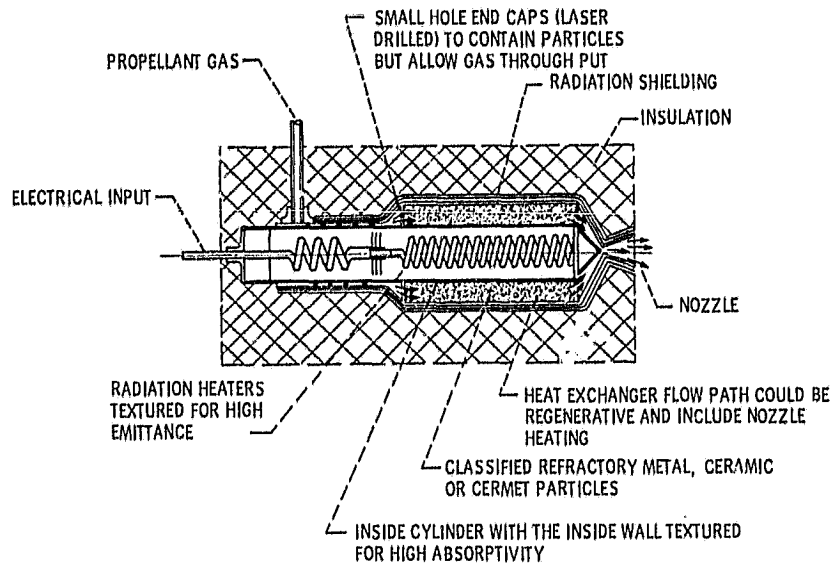

Figure 19. - LeRC porous media heat exchanger/resistojet.