

D13

N84 13414

A Study of the Charged Particle Calibration Requirements for the Deep Space Network

S. A. Townes

Communication Systems Research Section

This report presents a study made of the DSN charged particle calibration requirements. The effects of charged particles on navigation and timing systems were reviewed and it was proposed that a system based upon the Global Positioning System satellites be used to measure the charged particle content of the ionosphere. The system would be required to measure the total electron content of the ionosphere to the order of 10^{16} electrons/meter². Two types of systems were suggested as possible candidates for making these measurements.

I. Introduction

This report details the charged particle calibration requirements and reviews systems available for performing the calibration function for the Deep Space Network (DSN). It will be shown that a calibration system based upon the Global Positioning System (GPS) capable of measuring the ionospheric total electron content (TEC) to the order of 10^{16} electrons/meter² (el./m²) (1σ) every 60 seconds will provide the needed accuracy.

It is well known (Refs. 1,2) that radio signals traveling through a region of charged particles, like the earth's ionosphere or interplanetary plasma, can be corrupted by these particles in many ways. The DSN relies upon radio signals traversing these regions not only for data transmission but also for spacecraft orbit determination, and time and frequency synchronization. It is then necessary to determine the charged particle effects upon these signals and adequately calibrate them out to maintain the required accuracy.

Each flight project (Galileo, Voyager, etc.) has its own requirements for navigation accuracy, and time and frequency synchronization. The specifications are usually made in terms of range and velocity (or Doppler) measurement error, and synchronization accuracy requirements. In some cases, requirements for charged particle calibration are explicitly detailed but this is not necessarily a standard practice. Where it is done, the method of specification varies. It would be good practice in the future if each flight project would specify its charged particle calibration requirements. These requirements should be specified in a standard form such as TEC.

The Frequency and Timing System of the DSN currently uses a GPS based system as well as VLBI techniques for maintaining frequency and time synchronization. The GPS system will be used here although the same requirements apply to the VLBI system. The DSN requirements levied upon this system must also be considered since charged particles affect the signals from the GPS satellites.

The requirements detailed here are gleaned from many DSN documents and conversations with people in the navigation, tracking, and frequency and timing areas.

II. Proposed DSN Charged Particle Calibration Requirements

The proposed DSN charged particle calibration requirements have been determined from the navigation, and frequency and timing requirements of the Voyager, Galileo and International Solar Polar Mission (ISPM) projects as well as the requirements on the Frequency and Timing System. The requirements are first stated in these terms and then the required TEC measurements are derived.

The strongest requirement on range accuracy is that of Voyager. It requires 3 m or less (3σ) ranging noise at S-band for a 10 minute integration time at the 64 m dish ("Voyager-Uranus/Interstellar Mission, Support Instrumentation Requirements Document," PD 618-502, JPL internal document). If we ignore the 10 minute integration time, thus making it a tougher specification, the 3 m requirement at 2295 MHz translates to a TEC of 3.9×10^{17} el./m² (3σ). This comes from the fact that the effective range change, ΔR , is (Ref. 3),

$$\Delta R = \frac{AI}{f^2} \quad (1)$$

where $A = 40.3$ in MKS units, I is the TEC in el./m² and f is the frequency in Hz.

The ISPM requires the ability to measure velocity, hence Doppler, to 1 mm/s (assumed 3σ) for a 60 s count ("International Solar Polar Mission - Mission Requirements Document," Pub. 628-51, JPL internal document). This is the tightest specification of all of the projects. At 2295 MHz, this radial velocity imparts a frequency shift of approximately

$$f_D = -\frac{\dot{\rho}}{c} f_T = -7.65 \text{ MHz} \quad (2)$$

where $\dot{\rho}$ is the radial velocity, c is the speed of light and f_T is the transmitted frequency. This amount of Doppler at 2295 MHz due to charged particles would be caused by a changing TEC of 5.2×10^{15} el./m²/s. Here the effective frequency change is related to the TEC by (Ref. 3)

$$\Delta f = \frac{-A}{4\pi^2 fc} \cdot \frac{dI}{dt} \quad (3)$$

Over a 60 s interval this is a total TEC change of 3.1×10^{17} el./m² if we assume a constant rate.

The Frequency and Timing System performs time and frequency synchronization functions via the GPS signal at 1575.42 MHz (L_1). The proposed time synchronization accuracy is 10 ns (1σ) ("Deep Space Station [Mark III-77] and Deep Space Communications Complex [Mark IVA] Subsystem Requirements - Frequency and Timing Subsystem [1981-1986]," Pub. 824-13, JPL internal document). A 10 ns delay at the L_1 frequency would be caused by a TEC of 1.85×10^{17} el./m². The frequency synchronization is required to be known to $\pm 3 \times 10^{-14}$ $\Delta f/f$. Since this measurement is based upon a number of GPS time measurements the question is whether the 10 ns accuracy on the time measurements is sufficient. It can be shown that for a sufficient number of measurements over a length of time (e.g., 2 measurements a day for 10 days), the 10 ns requirement is good enough assuming that the only error in the measurements is due to charged particles.

In summary then, if the charged particle errors were the only errors measurement accuracy on the order of 10^{17} el./m² would be sufficient. Table 1 presents a summary of the individual requirements. Since charged particle errors are not the only ones in the navigation or frequency and timing systems it would be nice to keep these down even lower - say by a factor of ten. This would require the ability to measure TEC to 10^{16} el./m² every 60 s. The next section will address the feasibility of making such a measurement.

III. Charged Particle Calibration Systems

A. Introduction

The charged particle calibration system can be integrated into the spacecraft for navigation purposes or it can be independent of it. The charged particle information necessary for the time and frequency functions can be determined from the GPS satellite signals or independently of them. Each of these possibilities has its advantages and disadvantages.

The spacecraft borne systems, their performance and hardware implications are adequately discussed in Refs. 5 and 6. Suffice it to say that an onboard dual frequency ranging transponder is the best for navigation requirements. Spacecraft borne systems have the advantage that the charged particle measurements are made in the direction of the spacecraft so no mapping is required. The measurements also include the effects of all charged particles between the spacecraft and the tracking site. The range error over a pass has been estimated to be 0.5 m using this method (Ref. 6). A primary disadvantage of the type of system is the cost of the additional hardware for the spacecraft and ground systems. The use of such a system as the main charged particle calibration system for the DSN would also require that the ranging function be performed more often than is necessary for navigation purposes alone.

**ORIGINAL PAGE IS
OF POOR QUALITY**

Since this would require the use of one of the large dish antennas, it could be a severe inconvenience. With regard to the time and frequency measurements via GPS, a mapping would be needed of this charged particle data to the line of sight to the satellites (approximately 5% error).

The best general purpose approach to charged particle calibration then is one that is spacecraft independent. This reduces the necessity for costly hardware onboard the spacecraft and for continuous ranging. There are many methods to perform the calibration function but currently all but one can be ruled out. Ionospheric sounding techniques are not as accurate as needed by the DSN (Ref. 7) and a thorough job of top and bottom sounding as often as needed could be an expensive process. The VHF satellite beacons currently being used for making Faraday rotation measurements are becoming unavailable at the DSN tracking sites through the demise or relocation of the satellites. While this is certainly an accurate technique, there are no replacement satellites being planned for the foreseeable future. This leaves the dual frequency measurement technique as the most likely candidate. It has the capability of providing all of the accuracy required, and the GPS satellites are configured to provide the dual frequency signals exactly for this purpose.

The GPS satellites produce signals at 1575.42 MHz (L_1) and 1227.6 MHz (L_2) that are modulated with identical ranging codes (P-code). The TEC can be determined by measuring the difference in arrival times of these codes at the receiver as can be derived from Eq. (1). Information about the derivative of the TEC can also be determined from the Doppler on the carrier frequencies if needed as can be derived from Eq. (3).

There are two basic types of systems for determining the TEC via the GPS satellites. One requires a knowledge of the P-code and the other does not. There are advantages and disadvantages to each approach.

B. Delay-Lock Loop

The conventional approach requires a knowledge of the ranging code and tracks this code via some form of delay-lock loop (DLL) (Ref. 8). A generalized expression for the variance of the measurement noise in a DLL (in s^2) can be written (Ref. 9):

$$\sigma^2 = \left[\frac{K_1 B_n}{(C/N_0)} + \frac{K_2 B_i B_n}{(C/N_0)^2} \right] \cdot T^2$$

where

C/N_0 = carrier-to-noise density ratio,

B_n = one-sided code tracking loop noise bandwidth,

B_i = IF bandwidth for noncoherent code tracking loops,

K_1, K_2 = loop mechanization constants,

T = bit period.

It should be noted that this system is relatively complex and requires some time for initial acquisition. A coherent DLL is shown in Fig. 1.

C. Delay and Multiply

The second approach uses the standard delay and multiply technique (Ref. 8) for recovering the 10.23 MHz clock signal of the P-code. This is done at the L_1 and L_2 frequencies and the difference in clock phases is used to measure the delay due to the TEC. Note that if the difference is more than one clock cycle (97.75 ns) there is an ambiguity problem but this can usually be resolved in software.

Consider the baseband delay and multiply circuit with non-return to zero pulses, a 1/2 bit delay and a first order Butterworth low pass filter of bandwidth B followed by a phase lock loop of bandwidth B_L centered at 10.23 MHz, as shown in Fig. 2. The variance of the measurement noise (in s^2) is as follows (Ref. 10 and "TOPEX Notes," private communication to B. Crow from B. K. Levitt):

$$\sigma^2 = \frac{N B_L}{P} \cdot \frac{T^2}{4\pi^2}$$

$$P = \frac{2 S^2 \eta^2}{K^2} \left[\frac{K^2 (1 - \beta)^4 (2 + \beta)^2 + 16\eta^2}{C_1 C_2} \right]$$

$$N = U + V$$

$$U = \frac{2 S N_0 \eta^2}{C_1} \left[1 - \frac{(3 - \beta^2)(1 - \beta^2)(K^4 + K^2 \eta^2 + 6\eta^4)}{2\eta C_1 C_2} \right]$$

$$V = \frac{N_0^2 \eta^3 (1 - \beta^2)}{2T C_2}$$

where

$$\eta = 4BT$$

$$\beta = e^{-2BT}$$

$$K = 2\pi$$

$$C_1 = K^2 + \eta^2$$

$$C_2 = K^2 + 4\eta^2$$

The equations presented above are for single measurements but each delay measurement involves measurements at L_1 and L_2 . The variance of the delay measurement for equal power at L_1 and L_2 is then

$$\sigma_T^2 = 2\sigma^2$$

A simple comparison can be made between the delay and multiply system and the DLL as discussed. The delay and multiply circuit is shown in Fig. 1 and has an input bandwidth B such that $BT = 1.1$ and the phase-locked loop noise bandwidth is $B_L = 1$ Hz. The coherent (2Δ) DLL shown in Fig. 2 has a noise bandwidth $B_n = 1$ Hz also for comparison. Figure 3 presents the standard deviation of the delay measurement, σ_T versus the carrier power-to-noise power density ratio, C/N_0 . The important point to notice is that while the performance of the DLL is in general superior to that of the delay and multiply, in the region of interest ($\sigma_T = 0.35$ ns) there is about a 5 dB difference in the required C/N_0 . Note that for the large enough C/N_0 the performance of the two systems is essentially equivalent.

To put these results in perspective, the GPS P-code signal at L_2 has a received power of -166 dBW (-163 dBW at L_1), and a receiver with a noise temperature of 100 K would produce a C/N_0 of 43 dB-Hz. Reducing the receiver noise enough to meet the C/N_0 requirements for the delay and multiply and DLL would require noise temperatures of 4 K and 12 K respectively. This would require significant and expensive cooling. An alternative to reducing the noise temperature is adding an antenna with gain. The minimum gains required for the DLL and delay and multiply would be 10 dB and 16 dB respectively. The disadvantage of using an antenna with gain is the inherent directivity this implies. Ideally one would want the capability of receiving all visible satellites at one time but this does not appear to be possible. The best compromise would be some sort of electronically steerable array that could sequence through the visible satellites. The logistics of this would have to be considered in terms of how fast this could be accomplished in conjunction with taking the required readings from each satellite signal and locating each satellite in the sky with software. Some compromises must be made while still making most efficient use of the system.

One final point concerning the use of the GPS satellites needs to be considered. The time difference between the L_1 and L_2 P-codes onboard the satellite is specified to be no larger than 1.5 ns. This 1.5 ns translates to 4.3×10^{16} el./m² such that the ultimate limitation on TEC measurement may be this figure. It is not known currently what the delays really are for each satellite but this may in fact be something that can be measured and calibrated at a later date.

IV. Currently Available Equipment

The currently available commercial equipment uses the conventional DLL code tracking technology. The delay and multiply technique is used in development systems with the intent of future production.

The major manufacturers of the DLL based systems are Stanford Telecommunications Inc. (STI), Texas Instruments (TI), Magnavox and Rockwell-Collins. Examples of equipment that could perform the ionospheric calibration task are the STI 5010 and the TI-4100. The basic equipment price without any modification that might be required is on the order of \$150,000 for each of these units.

The delay and multiply based systems are currently under development at JPL and International SERRIES Technology Applications Corp. The JPL versions are the SERIES-X receiver and the Satellite L-Band Ionospheric Calibration (SLIC) system (Ref. 11). Current accurate prices are not known for this equipment but it is conceivable that it could be less expensive than the DLL based receivers.

V. The Ideal System and Minimum Requirements

The ideal charged particle (ionospheric) calibration system based upon the GPS satellites would have the following characteristics:

- (1) The ability to monitor all visible satellites simultaneously (continuously).
- (2) The ability to measure L_1/L_2 P-code time of arrival differences to 0.350 ns (1σ) at least every 60 s providing a TEC measurement accuracy of 10^{16} el./m².
- (3) The ability to measure L_1/L_2 Doppler to 1 MHz (equivalent to a changing TEC of 5.16×10^{14} el./m²/s which in turn is equivalent to 0.1 mm/s velocity at 2295 MHz).
- (4) A mapping/modeling capability for determining the line of sight charged particle information from the GPS data.

This may prove expensive since 4 or 5 complete L_1/L_2 single satellite receivers would be needed in addition to four antennas. What then are the minimum requirements?

- (1) The ability to monitor at least one of the visible satellites.
- (2) The ability to measure the L_1/L_2 P-code (or P-code clock) time of arrival differences to 0.350 ns (1σ) every 60 s providing a TEC measurement on the order of 4×10^{16} el./m² or less.

- (3) A mapping/modeling capability for determining the line of sight charged particle information from the GPS data.

The technology is currently available for the ideal system as well as the minimum system. Any of the previously discussed available systems could meet these minimum requirements.

VI. Conclusion

The GPS system has been recommended as a viable means of providing charged particle calibration for navigation and timing purposes. It is capable of providing the near earth calibration data needed and at the accuracy required.

The one possible problem with this system is that the Department of Defense controls it and may choose to change the P-code or otherwise degrade the system accuracy. The SLIC system is felt to have an advantage in this area since it

does not require knowledge of the P-code. The likelihood of this event arising, however, is felt to be remote and thus should not constitute a major consideration.

The use of a GPS based calibration system should not preclude other systems. In fact, the DSN is encouraged to continue requesting beacons on geostationary satellites for making Faraday rotation measurements. A Faraday rotation system is an inexpensive (ground segment) back up or supplement to the GPS system. Calibration systems aboard deep space probes, etc. can also provide information about interplanetary charged particles that the GPS based system cannot.

The DSN should also make an effort to make its ionospheric/charged-particle measurements available to the radio science community. These data will be of use to those investigating ionospheric phenomena and this in turn will ultimately benefit the DSN. Through a better understanding of the ionosphere, better mapping and modeling can be accomplished thus improving navigational and timing accuracy.

References

1. Lawrence, R. S., Little, C. G., and Chivers, H. J. A., "A Survey of Ionospheric Effects Upon Earth-Space Propagation," *Proceedings of the IEEE*, Vol. 52, no. 1, pp. 4-27, January 1964.
2. Davies, K., *Ionospheric Radio Propagation*, Dover Publications, Inc., New York, 1966.
3. Yip, K. W., and Mulhall, B. D., "A system analysis of error sources in the technique used for ionospheric calibration of deep space probe radio metric data," *JPL Tech. Report 32-1526*, Vol. XVIII, pp. 48, December 15, 1973.
4. Yuen, J. H., Ed., *Deep Space Telecommunications Systems Engineering*, JPL Pub. 82-76, July 1982, p. 60.
5. Mulhall, B. D., "Charged-Particle Calibration System Analysis," *JPL Space Programs Summary 37-64*, Vol. II, pp. 13-21.
6. von Ross, O. H., and Mulhall, B. D., "An Evaluation of Charged Particle Calibration by a Two-Way Dual-Frequency Technique and Alternatives to this Technique," *JPL Technical Report 32-1526* Vol. XI, pp. 42-52, October 15, 1972.
7. Garriott, O. K., da Rosa, A. V., and Ross, W. J., "Electron content obtained from Faraday rotation and phase path length variations," *J. Atmos. and Terr. Physics*, Vol. 32, pp. 705-727, 1970.
8. Spilker, J. J., *Digital Communications by Satellite*, Prentice-Hall, Inc., Englewood Cliffs, N. J., 1977.
9. Martin, E. H., "GPS User Equipment Error Models," *Global Positioning System*, Institute of Navigation, Washington, D. C., 1980, pp. 109-118.
10. McCallister, R. D., and Simon, M. K., "Cross-Spectrum Symbol Synchronization," *ICC Conference Record 1981*, pp. 34.3.1-34.3.6.
11. MacDoran, P. F., Spitzmesser, D. J., and Buennagel, L. A., "SERIES: Satellite Emission Range Infrared Earth Surveying," *Proceedings of the Third International Geodetic Symposium on Satellite Positioning*, Las Cruces, New Mexico, February, 1982.

Table 1. DSN requirements used for determining proposed charged particle calibration requirements

Requirement	Error	TEC equivalent (electron/m ²)
Range ^a	3 m (3 σ)	3.9×10^{17}
Velocity ^a	1 mm/s (3 σ)	3.1×10^{17} (over 60 s)
Time sync ^b	10 ns (1 σ)	1.8×10^{17}
Frequency sync	$\pm 3 \times 10^{-14} \Delta f/f$	-

^a2295 MHz
^b1575.42 MHz

ORIGINAL PAGE IS
OF POOR QUALITY

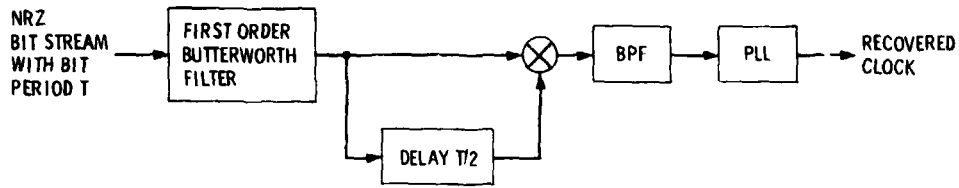

Fig. 1. Baseband delay and multiply circuit

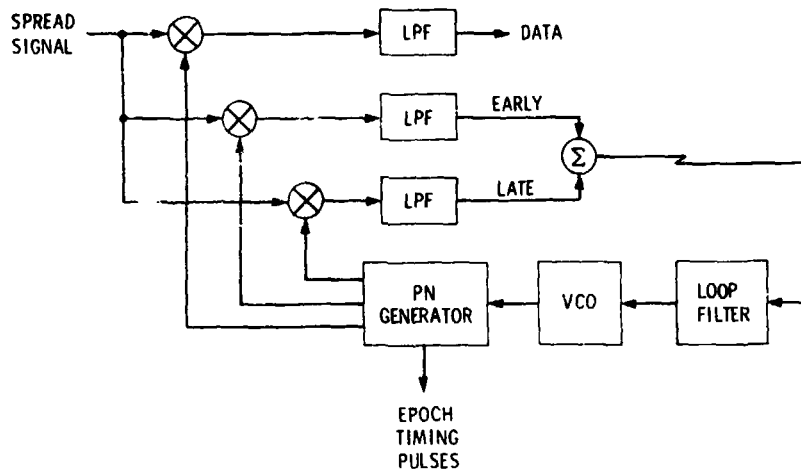

Fig. 2. Coherent delay-lock loop (DLL)

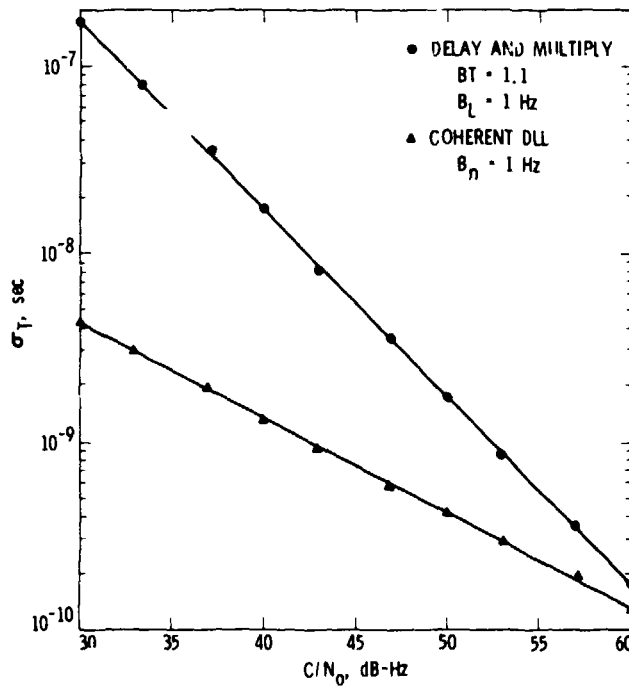

Fig. 3. Comparison of delay-lock loop and delay and multiply circuit