

NASA Conference Publication 2304

NASA-CP-2304 19840013335

NASA Administrative Data Base Management Systems—1983

FOR INFORMATION

Administrative Data Base Management Systems

*Proceedings of a conference held at
NASA Goddard Space Flight Center
Greenbelt, Maryland
May 25-26, 1983*

NASA

NASA Conference Publication 2304

NASA Administrative Data Base Management Systems—1983

James D. Radosevich, *Editor*
NASA Headquarters

Proceedings of a conference held at
NASA Goddard Space Flight Center
Greenbelt, Maryland
May 25-26, 1983

NASA

National Aeronautics
and Space Administration

**Scientific and Technical
Information Branch**

1984

FOREWORD

This Technology Conference is the second such conference which the NASA Headquarters ADP Management Branch has sponsored. The first conference had the same theme (NASA Administrative Data Base Management Systems), and it was held at the Jet Propulsion Laboratory on May 26 and 27, 1982. The proceedings of the first conference were published as NASA Conference Publication 2254.

The purpose of these conferences is to provide an open forum for constructive exchange of information among NASA technical Automatic Data Processing (ADP) personnel. The theme for each conference is selected by conducting a survey of NASA ADP personnel. The theme for each conference is selected by conducting a survey of NASA ADP personnel through the NASA Inter-Center Committee on ADP.

James D. Radosevich, NASA Headquarters ADP Management Branch (Code NXD-2), was conference chairman. The conference was held at the Goddard Space Flight Center (GSFC) on May 25 and 26, 1983. Conference arrangements at GSFC were the responsibility of Paul H. Smith, Head, Information Management Branch of the Applications Directorate; Joseph L. Barksdale, Assistant Director for Center ADP Planning; and Donna M. Smith, Information Management Branch.

Presentations were made by 15 of the 73 people who attended. In addition the attendees had the opportunity to tour several GSFC data processing facilities and to attend a dinner meeting at which a presentation was made by Barry E. Jacobs, Assistant Professor of Computer Science at the University of Maryland.

CONTENTS

	<u>Page</u>
FOREWORD	iii
CONTENTS	v
AGENDA	vi
List of Participants and Attendees	ix
PRESENTATIONS AND PAPERS	
NASA's EMERGING PRODUCTIVITY PROGRAM	1
ACTION INFORMATION MANAGEMENT SYSTEM (AIMS): A USER'S VIEW	9
AUTOMATED RTOP MANAGEMENT SYSTEM	13
RAMIS DBMS Update	19
INTERCENTER PROBLEM REPORTING AND CORRECTIVE ACTION SYSTEM (PACAS)	31
INTEGRATING MICRO-COMPUTERS WITH A CENTRALIZED DBMS: ORACLE, SEED, & INGRES	55
QUANTITATIVE EVALUATION OF THREE DBMS: ORACLE, SEED, & INGRES	75
AUTOMATED ADMINISTRATIVE DATA BASES	85
METHOD FOR ACCESSING DISTRIBUTED HETEROGENEOUS DATABASES	89
NASA SCIENTIFIC AND TECHNICAL INFORMATION SYSTEM (STI) AND NEW DIRECTORY OF NUMERICAL DATA BASES	105
SPECIFICATIONS FOR A FEDERAL INFORMATION PROCESSING STANDARD DATA DICTIONARY SYSTEM	121
NASA-WIDE STANDARD ADMINISTRATIVE SYSTEMS	145
DBMS AS A TOOL FOR PROJECT MANAGEMENT	153
USE OF DBMS IN MULTI-STEP INFORMATION SYSTEMS FOR LANDSAT	159

Administrative Data Base Management System
Technology Conference
May 25-26, 1983
AGENDA

May 25, 1983

- 9:00 Opening Remarks and General Announcements
(GSFC/Paul Smith and NXD/Jim Radosevich)
- 9:15 NASA's Emerging Productivity Program
(NAD/David Braunstein)
- 9:45 Office Automation Overview (NXD/Wallace Velander)
- 10:00 Action Information Management System (AIMS)
(EE-8/Michael Wiskerchen)
- 10:25 Break
- 10:35 Automated RTOP Management System
(RP-4/Phyllis Hayes)
- 11:30 RAMIS DBMS Update (GSFC/James Head)
- 12:00 Intercenter Problem Reporting and Corrective
Action System (PRACAS) (KSC/Georgia Brock)
- 12:30 Lunch
- 1:15 Integrating Micro-Computers with a Centralized
DBMS (LaRC/Jerry Hoerger)
- 2:00 Quantitative Evaluation of Three DBMS: Oracle,
Seed, & Ingres (GSFC/Regina Sylto).
- 2:30 Break
- 2:40 Automated Administrative Data Bases
(GSFC/Susan Reising and Michele Marrie)
- 3:15 Open Discussion on Administrative DBMS Problems
led by Jack Hodge of GSFC
- 3:45 Tours of GSFC Facilities
- Vector Processor
- Massively Parallel Processor
- Pilot Climate DBMS Demonstration
- LANDSAT System
- 5:30 Cocktail Hour and Dinner Meeting
Guest Speaker: Barry Jacobs
Topic: Method for Accessing Distributed
Heterogeneous Data Bases

Administrative Data Base Management System
Technology Conference
May 25-26, 1983
AGENDA

May 26, 1983

- 9:00 NASA Scientific and Technical Information System (STI)
and New Directory of Numerical Data Bases
(NIT/John Wilson)
- 9:45 Specifications for a Federal Information Processing
Standard (FIPS) Data Dictionary System
(NBS/Alan Goldfine)
- 10:30 Break
- 10:40 NASA-Wide Standard Administrative Systems
(GSFC/Paul Schneck)
- 11:30 Lunch
- 1:00 DBMS as a Tool for Project Management
(GSFC/Henry Linder)
- 1:40 Use of DBMS in Multi-Step Information Systems
for LANDSAT (GSFC/(Carey Noll)
- 2:15 Tours of GSFC Facilities
- Network Control Center
- Science and Applications Computing Center
- 4:15 Adjourn

Administrative DBMS Technology Conference
May 25-26, 1983

PARTICIPANTS AND ATTENDEES

Headquarters

Joseph L. Bishop (TS)
David R. Braunstein (NAD)
Janelle Brown (C)
Lawrence P. Chambers (EBF-3)
R. V. Cortez (TS)
Nancy Evans (EL-4)
John A. Glaab (EZ-7)
Dana L. Hall (DE)
Phyllis A. Hayes (RP-4)
Robert C. Karpen (DR)
Charles E. Mason (NX-2)
Doug Pearson (NXD-2)
James D. Radosevich (NXD-2)
Russell S. Rice (NXD-2)
Harry C. Sperry (NXI-2)
Robert R. Stephens (T)
Wallace Velandar (NXD-2)
Al Weaver (NXD-2)
Carl K. Wilbert (NHC)
John Wilson (NIT-42)
Michael J. Wiskerchen (EE-8)

Goddard Space Flight Center (Cont.)

Julie Kipper (923)
Henry Linder (931)
Candace D. Livingston (201)
C. H. Looney (700)
Michele D. Marrie (901)
Kenneth H. McIntosh (532.2)
Carey E. Noll (931)
Alice E. Rector (732)
Susan A. Reising (901)
Mary G. Reph (931.2)
Rolland M. Ridgeway (206.2)
Damian R. Romano (206)
Paul Schneck (900)
Paul H. Smith (931)
Regina Sylto (931)
Barbara A. Walton (200.6)

Jet Propulsion Laboratory

Nellis C. Adams
Michael D. Martin (168-514)

Ames Research Center

David Durbin (233-3)
Janet Konrath (233-3)
Michael Romiez (200-14)

Marshall Space Flight Center

Ross B. Zorn [BCSS]

National Space Technology Laboratory

Patricia G. Penton (HA-41)

Lewis Research Center

Jack Kovacs (142-3)
Donald R. Packe (142-2)

Johnson Space Center

John Arnold (FD-64)

Langley Research Center

Jerome C. Hoerger [PRC] (179)
Iris B. Russell (179)
Fred Waynick (179)

Kennedy Space Center

Jim Akin (SI-CSD)
Georgia H. Brock (TI-LPS-2)
James J. Paley [CSC-913]

Goddard Space Flight Center

Joseph D. Barksdale (200.6)
John H. Berbert (931)
Diane Bittner (206)
Ronald G. Brunner (206)
Lloyd Carpenter (200.6)
Kenneth W. Davidson (191.0)
John Emond (151.1)
Joseph P. Fonte [Pacer Sys] (920)
James L. Head (206)
John E. Hodge (901)
Larry G. Hull (532.2)
Joyce Jarrett (901)

CSC

Pearson C. Caldwell
Lawrence A. Vance
John W. Wood

Planning Research Corporation

David Lavery
Patricia M. Michel

Administrative DBMS Technology Conference
May 25-26, 1983

PARTICIPANTS AND ATTENDEES
(Continued)

Systems and Applied Sciences Corp.

Edwin P. Cutler

National Bureau of Standards

Alan Goldfine

David K. Jefferson

(Mail Code)

[Contractor Name]

1. NASA'S EMERGING PRODUCTIVITY PROGRAM

David R. Braunstein
Executive Director, Special Project
National Aeronautics and Space Administration
Washington, D.C.

ABSTRACT

NASA, as one of the nation's foremost research and development agencies, has established a reputation for superior R&D management. Recognizing that severe budgetary and manpower constraints are likely to become the conditions under which we operate in the years ahead, NASA formed a Productivity Steering Committee to develop an agency-wide approach to productivity and quality. This approach would provide, in the long term, the best possible work at the highest level of quality under the constraints of a constant work force and tighter budget. The chairman of this committee is the NASA Administrator and the membership includes key Headquarters Administrators and all Center Directors.

NASA's agency-wide effort, established less than one year ago, is focused on seven strategic goals and is decentralized in its implementation and centrally coordinated by the Steering Committee. No centralized productivity staff is contemplated. Instead, part-time productivity coordinator networks and working groups have been formed at Headquarters and at the centers to begin specific initiatives for the seven goals. Under these goals several agency-wide tasks have been initiated, which include reducing paperwork, cutting procurement leadtime, increasing contractors' productivity, developing common administrative ADP, promoting office automation, initiating NASA Employee Teams, and reducing impediments to productivity.

As evidence of management's commitment to productivity, the Agency recently published its eight top goals; prominent among them is to "Establish NASA as a leader in the development and application of advanced technology and management practices which contribute to significant increases in both Agency and national productivity."

Productivity Program at NASA

NASA has become engaged in a new high-payoff productivity program that is quite different from its normal projects. It is similar in that it involves an ambitious objective, major unknowns and difficult measurements, but instead of an aircraft or a satellite development, the application is to people and the management process. One might classify the program as "high-tech" management because of the similarity in "difficult to overcome" issues

between the productivity program and other NASA hardware development projects. In productivity the development issues involve beueaucratic processes, congressional, organizational and contractor planning and control, and the built-in constraints in Government approaches to doing business. Our Administrator's goal is for NASA to become a leader in the development and application of productivity and quality concepts at every level of NASA management. The program is called PIQE for Productivity Improvement and Quality Enhancement, and we usually refer to it as simply the Productivity or PIQE program (productivity and quality going together and being equally important).

Productivity is important to NASA fundamentally because we have many more good ideas that need funding than we have dollars and people available to support them. Consequently, in a very tight budget environment it is in our own best interest to become as effective as possible in increasing our Agency output relative to the people and dollar resources appropriated to us by Congress. In addition we are an aggressive organization with very high morale and have a relatively low tolerance for program failures and bu-reaucratic nonsense. We take great pride in our creative environment and our technical and management reputation and see the productivity program objective as a means to focus our management attention on initiatives to further improve the working environment for NASA employees and to increase its organizational effectiveness. As implied in the figure below productivity and creativity are closely linked in an R&D environment.

Controls: That Discourage Variation from Norm

Budgets: Without Leeway for Discretion

Concensus/Committee: Emphasis Leading Toward Too
Much Uniformity

Recognition System: Encouraging Low Risk for Rewards

Centralization Management: Resulting in Layering, Too
Many People Who Can Say No

Credit Due Limits: Failure to Give Recognition for Unusual
Ideas in a Person's Job, Tendency to
Forget Individual and Reward Supervisor

Figure 1-1. NASA PIQE Program Factors That Hamper
Productivity and Creativity.

Besides NASA's own self-interests, productivity is important to the nation because of the impact it can have in maintaining a competitive technical and business position in the United States. Over the last five years productivity increases in the United States have been around zero. For most of the post-World War II period it was about three and a half percent. This is in sharp contrast to other major industrial nations which are enjoying larger positive productivity increases so that our productivity trend is widely recognized as an issue of national concern. Many corporations see it as a "survival" issue since other countries, notably Japan and Germany, are perceived to produce much better quality products and seem to have overtaken the U.S. in some rather basic and important industries such as steel, automobiles, and some high-volume electronic equipment. As an important R&D Agency in the United States, NASA and its contractors have an opportunity to make a significant contribution by determining we can improve our productivity, measure the results, and institutionalize its methods and approaches for long-term continuous pay-off.

Challenges of a Credible Government Program

Over the last several years, industry has taken an active interest in productivity because of the basic issues of maintaining competitiveness and economic survival. There are many signs of this interest in the press, in trade journal articles, and in the growth of professional organizations. For example, the American Productivity Management Association has grown in the last 2 years from only 15 members to over 250 by word-of-mouth. Attesting to the importance of productivity to corporations, most productivity directors report to the corporation president or chief-executive officer, and productivity goals are part of the corporation's strategic planning.

However, at NASA the challenge of maintaining interest in productivity will be more difficult. Unlike our corporate counterparts, we don't face the same economic issue. Where is our competition? Can you see NASA going out of business? Thus, while many of the very same issues of productivity in the organization exist in industry and in NASA, the sense of urgency or importance is different and the commitment will be more difficult to sustain.

NASA's Administrator and its top executives recognize that productivity is a national problem and believe we can do something about it at NASA. They recognize that there is both a payoff for the employee in a better, more satisfying job, and a payoff for the organization, using streamlined planning and execution processes, and encouraging a greater team-like environment. In order to signal the importance of productivity to the NASA community, a top-level steering committee was formed. NASA is not being naive about the challenges in maintaining a credible program, but it recognizes the need to develop one. Its top management is committed to make it successful.

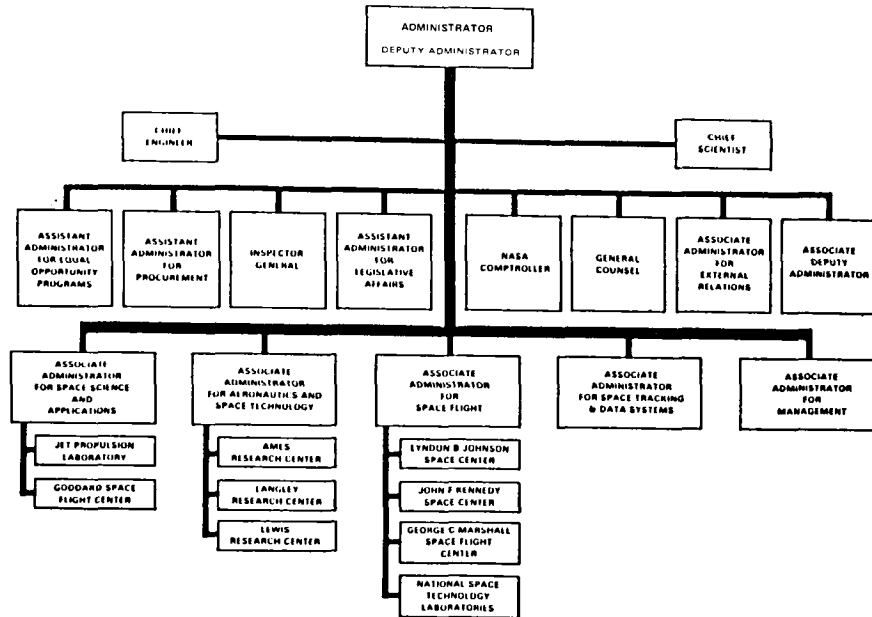

Figure 1-2. NASA Productivity Steering Committee.

Elements of NASA Program

NASA is a unique R&D organization regarded by many in Washington as one of the best-run government agencies. The approach NASA adapted in planning its productivity program was to build on what is believed to be its inherent strengths, by emphasizing a program that focused on its people and a creative environment. To this end, efforts were undertaken to increase employee involvement in the decisionmaking process and to examine approaches to provide greater recognition and rewards for successful efforts. The productivity program aims to streamline the paperwork and control processes to permit a more creative, less burdensome work environment and to free the professional work force to spend greater time on project planning and execution.

- **STREAMLINE MANAGEMENT PROCESS, REDUCE IDENTIFIED IMPEDIMENTS**
- **INCREASE CAPABILITIES, COMMITMENT, MOTIVATION OF STAFF**
- **STIMULATE INDIVIDUAL AND GROUP INITIATIVE TOWARD PRODUCTIVITY IMPROVEMENTS**
- **PROMOTE THE INTRODUCTION OF EFFECTIVE MANAGEMENT APPROACHES, ADVANCED TECHNOLOGY, AND INSTITUTIONAL MODERNIZATION**
- **INCREASE TIME AVAILABLE FOR PROFESSIONAL STAFF TO BE CREATIVE**

Figure 1-3. NASA PIQE Program Key Objectives.

Further, the productivity program involves a long-term commitment by top management. This has been important so that middle management support would evolve. Initial management reaction in the early stages of the program planning at NASA was similar to that of other successful corporations starting a productivity and quality improvement program: "Productivity seems to be more political than real, and I only have time available to spend on initiatives that are really important." It was necessary to overcome the basic feelings that "productivity was just another Washington fad." Mr. James Beggs, our Administrator, dealt with these initial reactions by first taking NASA's top managers to Westinghouse Corporation's Productivity Center for an orientation. There, the Associate Administrators and Center Directors heard, first-hand, what convinced Westinghouse that productivity was an important strategic goal which needed special emphasis. Then, a series of briefings, lectures and workshops were initiated to raise the consciousness level of our management and to allow them to develop their own interests and ideas. Finally, in order to help plan our program, we surveyed the NASA Headquarters Center Program Managers and NASA contractors to determine their perspectives on impediments to productivity. Based on these comments, we are starting to develop suggestions as to what NASA should do to improve its productivity. The results provide insights into what we could do to simplify our management planning, budgeting, coordinating, and controlling. Focal points for productivity were identified at the major NASA organizational elements, and teams of managers from different parts of the organization have been formed to look into the issues raised and to recommend approaches to simplify the project manager's job.

Initial Thrusts

In initiating the NASA Productivity Program, efforts were focused in seven strategic areas. Several short-term initiatives were immediately undertaken in response to the "impediment surveys" taken of NASA Project Managers in our field centers. The key initial objectives were to streamline the planning and budgeting process, reduce paperwork, promote office automation, and cut down procurement leadtime since these areas were frequently mentioned by the professional staff as impediments to their productivity. Task teams were formed to recommend corrective action that could alleviate the perceived problems. We expect to impact management practices with these investigations and to encourage new approaches and the use of new technology into the NASA management process.

- HEIGHTENING MANAGEMENT AND EMPLOYEE KNOWLEDGE AND AWARENESS
- ENCOURAGING PIQE MANAGEMENT PRACTICES AND NEW TECHNOLOGY TO INCREASE PRODUCTIVITY
- BROADENING EMPLOYEE PARTICIPATION IN MANAGEMENT DECISION-MAKING
- ESTABLISHING PROCESSES FOR DEFINING PRODUCTIVITY GAUGES AT EACH ORGANIZATIONAL LEVEL
- IDENTIFYING PIQE IMPEDIMENTS AND OPPORTUNITIES FOR GREATER PRODUCTIVITY
- DEVELOPING APPROACHES AND INCENTIVES FOR PROJECT AND CONTRACTOR PIQE ADVANCES
- SHARING OBJECTIVES AND RESULTS OF CENTER PIQE EFFORTS WITH OUR PEOPLE

NASA HQ HEAD 10011
470

Figure 1-4. NASA PIQE Program SEVEN TASK FOCUS.

Key initiatives started and aimed at promoting participative management and increasing employee involvement in the NASA's decisionmaking processes are 1) NASA Employee Teams, 2) Nominal Group Technique Training for supervisors, and 3) revitalization of our employee suggestion system. Our NASA Employee Teams involve training employees in the "quality circle" processes that provide insight and techniques in participative management and team problem solving. Similarly, we initiated the nominal group technique training and a new employee suggestion program to increase our employee participation in addressing ways to increase our organizational and operational effectiveness.

Productivity trends measurement for our agency is being pursued on a decentralized level. We recognize the need to engage our employees in the goal-setting process and feel that meaningful productivity measures should be decided at the branch level. Consequently, our approach has been to decentralize the measurement process to the point at which groups of employees can agree on their own objectives and measurements of their own progress. In this way we expect to build in the process of productivity awareness and take advantage of the pride and natural desire of the staff to improve their efforts. The objective will be to increase results and accomplishments at each level relative to costs in terms of manpower and dollar investment.

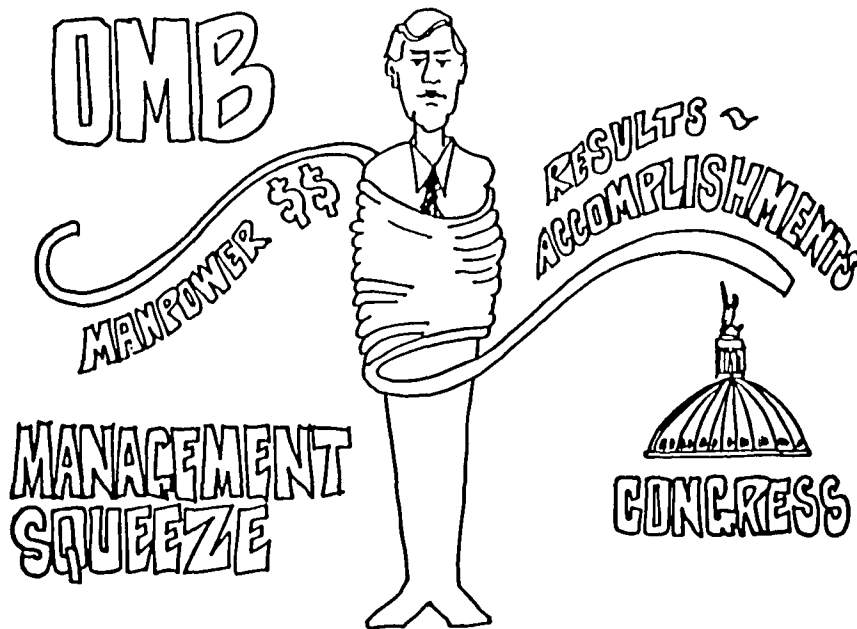
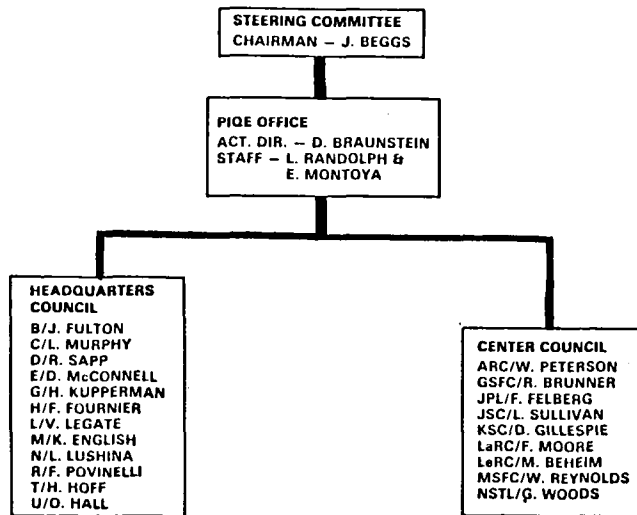

Figure 1-5

Finally, we will hold periodic conferences and briefings to allow each NASA organization activity and our contractors to discuss their respective programs and ideas to improve productivity. Our objective here is simple. We recognize the motivation for the organization to learn and develop its own techniques and approaches, and we have facilitated this learning process by providing a forum for discussion. In order to provide a continuous structure for this process, a productivity council consisting of representatives from the various NASA organizations has been set up, and we have initiated meetings with our contractors.

Overall Strategy

We recognize that for NASA the key to achieving productivity improvement is through employee involvement, both civil servant and contractor, in all phases of our activities. While NASA's leadership role in research and development demands increased investment in technological advances, technology alone is not sufficient unless supported by motivated and dedicated people. It takes people to put this new technology to work, people who are challenged and willing to accept change and embrace new ideas.



NASA HQ MAR 1986 11
9 11 82

Figure 1-6. PIQE Coordination Network.

Our industrial contractors, concerned with their competitive edge, and NASA's own concern with our nation's aerospace preeminence, dictates that we must strive to improve our individual, organizational, and national productivity. By encouraging and rewarding increased productivity through the use of advanced technology and management innovation, NASA will be in a position to make a significant contribution to the nation's productivity in both the public and private sector.

In our productivity briefings, we have found that NASA's employees and our contractor community are receptive to this challenge. One need only examine NASA's accomplishments over its brief 25-year history to be assured that the talent and the capability exist in our combined organizations. The NASA team expects to provide the continued leadership in aeronautics and aerospace, and in addition, to make new strides in productivity improvement and quality enhancement.

2. ACTION INFORMATION MANAGEMENT SYSTEM (AIMS): A USER'S VIEW

Michael Wiskerchen
Office of Space Science and Applications

The AIMS project at NASA Headquarters has now reached its fourth year of life. It was born out of the frustrations and needs of the technical management staff of NASA Headquarters. The complex management tasks connected to NASA's flight programs demanded modern information technology tools. The traditional batch mode data processing office did not fulfill the needs of this emerging user group. It is important at this time to reflect on the successes and failures of this project to satisfy the needs of this technical management group.

The primary objective of the AIMS project was to establish a user-defined information system to fulfill "user needs" at NASA Headquarters. I specifically stated user needs and not user requirements. The difference between needs and requirements is significant. Since none of the potential users had experience with such systems, any stated requirements could only be perceived from limited knowledge. A requirements study at that early stage could only be the summation of our total ignorance. From our technical backgrounds we knew that certain baseline conditions should be met. A systems engineering approach must be used. Our experience with flight system hardware and software also dictated an approach. The architecture of the system should be an interactive distributed system available to all Headquarters users. The system should possess a user-friendly query language data base and all software should be commercially available to reduce development and maintenance costs.

The methodology used to establish the project was driven by both engineering and political considerations. A dedicated user team was set up with membership from each principal office. The project was established as an R&D pilot activity. This was essential because it was our traditional means of doing technical projects, and also it avoided the usual hassles involved with procuring management ADP equipment. It was called a pilot and developed as a pilot to avoid the pressures of having to have a development system that was used on our mandatory daily tasks. If any particular part of the system did not work as expected, it could be modified or dropped without undue difficulty. We hired contractors to work with us on program development and training of our personnel. The central computer in the system was obtained by using a flight mission computer at Goddard Space Flight Center, and the necessary commercial software was put on it. The Headquarters peripheral equipment was either purchased or leased.

Over the past several years we have learned a great deal from this project. The most important effect of the AIMS project was the establishment of a close-knit team of users across the Headquarters offices. The success will be evidenced by the presentation of Phyllis Hayes following this talk. I will concentrate the rest of my presentation on some of the failures of the AIMS pilot. For one thing, NASA Headquarters is not suitably organized to carry out all of the required tasks of an R&D project. It was clearly recognized that in other R&D projects NASA Headquarters plays a significant management role but depends completely on field center project support for all engineering tasks. Because of this Headquarters inexperience, full project status was never achieved. Insufficient contract personnel were hired; no Headquarters personnel were directly assigned to the project, and no integrated training program was established. This also led to hardware and software procurements always being behind schedule.

Even with all of these difficulties, the AIMS pilot project found the road to success. This was primarily due to a dedicated group of users from Codes E, N, R and T who would not let the project fail. Ames Research Center was designated as the lead field center to work with Headquarters. ARC gave the AIMS pilot full project status with the necessary personnel assigned to it. Key milestones and tasks were established for the project. The first results, the RTOP system, will be demonstrated to you in the following talk. This RTOP system can be seen as a true success and something that should be emulated in future tasks.

In conclusion I think several things should be recognized. NASA should always work from its organizational strengths as a Headquarters-Center partnership. The strong teamwork and friendships developed during this effort should be utilized and encouraged by the Agency for establishing future management systems.

- USER DEFINED SYSTEM TO FULFILL "USER NEEDS" AT NASA HEADQUARTERS
 - INTERACTIVE DISTRIBUTED SYSTEM AVAILABLE TO ALL HQ USERS
 - "USER FRIENDLY" QUERY LANGUAGE DATA BASE
 - COMMERCIALY AVAILABLE SOFTWARE

Figure 2-1. Aims Objectives.

- FORM HEADQUARTERS USER TEAM
- ESTABLISH R & D PILOT PROJECT
 - USE EXISTING FLIGHT PROJECT COMPUTER AT GSFC
 - BUY OR LEASE PERIPHERAL EQUIPMENT FOR HEADQUARTERS USERS
 - BUY COMMERCIALY SUPPORTED SOFTWARE
 - EMPLOY CONTRACTOR DEVELOPMENT SUPPORT
- ESTABLISH FULL TRAINING PROGRAM

Figure 2-2. Initial Methodology.

- HEADQUARTERS UNPREPARED TO CONDUCT ALL ASPECTS OF R & D PILOT PROJECT
 - PROJECT STATUS FOR PILOT NEVER REALIZED
 - CONTRACT PERSONNEL INSUFFICIENT
 - NO HEADQUARTERS PERSONNEL DIRECTLY ASSIGNED TO PROJECT
 - INTEGRATED TRAINING PROGRAM NEVER ESTABLISHED
 - HARDWARE & SOFTWARE PROCUREMENTS BEHIND SCHEDULE
 - TRADITIONAL CENTER INVOLVEMENT LACKING

Figure 2-3. Lessons Learned.

- NEVER-SAY-DIE USERS
- FULL CENTER INVOLVEMENT (AMES RESEARCH CENTER)
 - FULL PROJECT STATUS
 - KEY MILESTONES ESTABLISHED
 - POSITIVE RESULTS (RTOP SYSTEM)
- METHODOLOGY MUST INCLUDE ORGANIZATIONAL STRENGTHS

Figure 2-4. Road to Success.

3. AUTOMATED RTOP MANAGEMENT SYSTEM

Phyllis Hayes
Headquarters Code RP-4

FY 1983

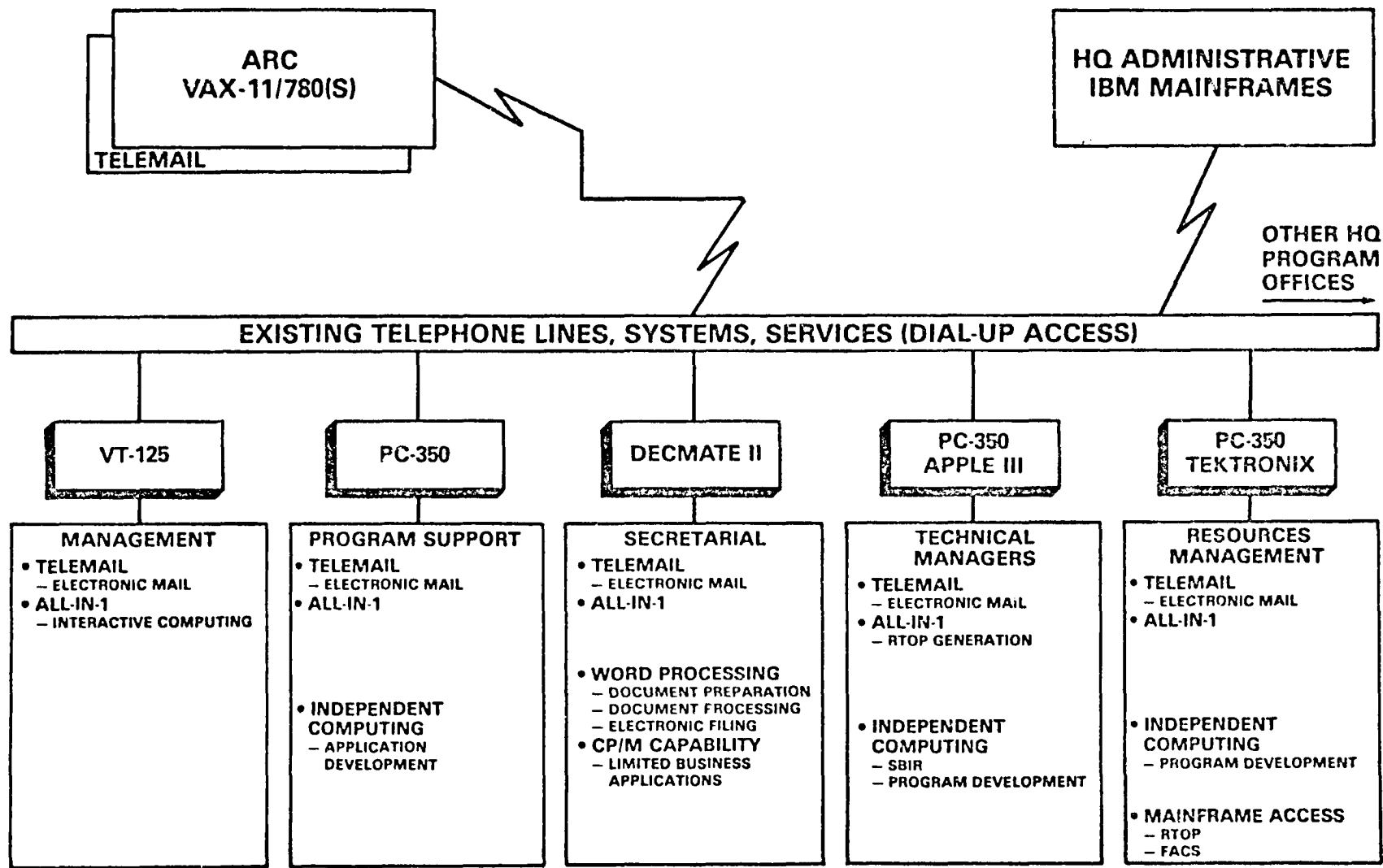

14

NASA

Figure 3-1. OAST Electronic Information Systems Network.

OAST HQS-RP23-1036(1) 1/16/83

FY 1983, FY 1984

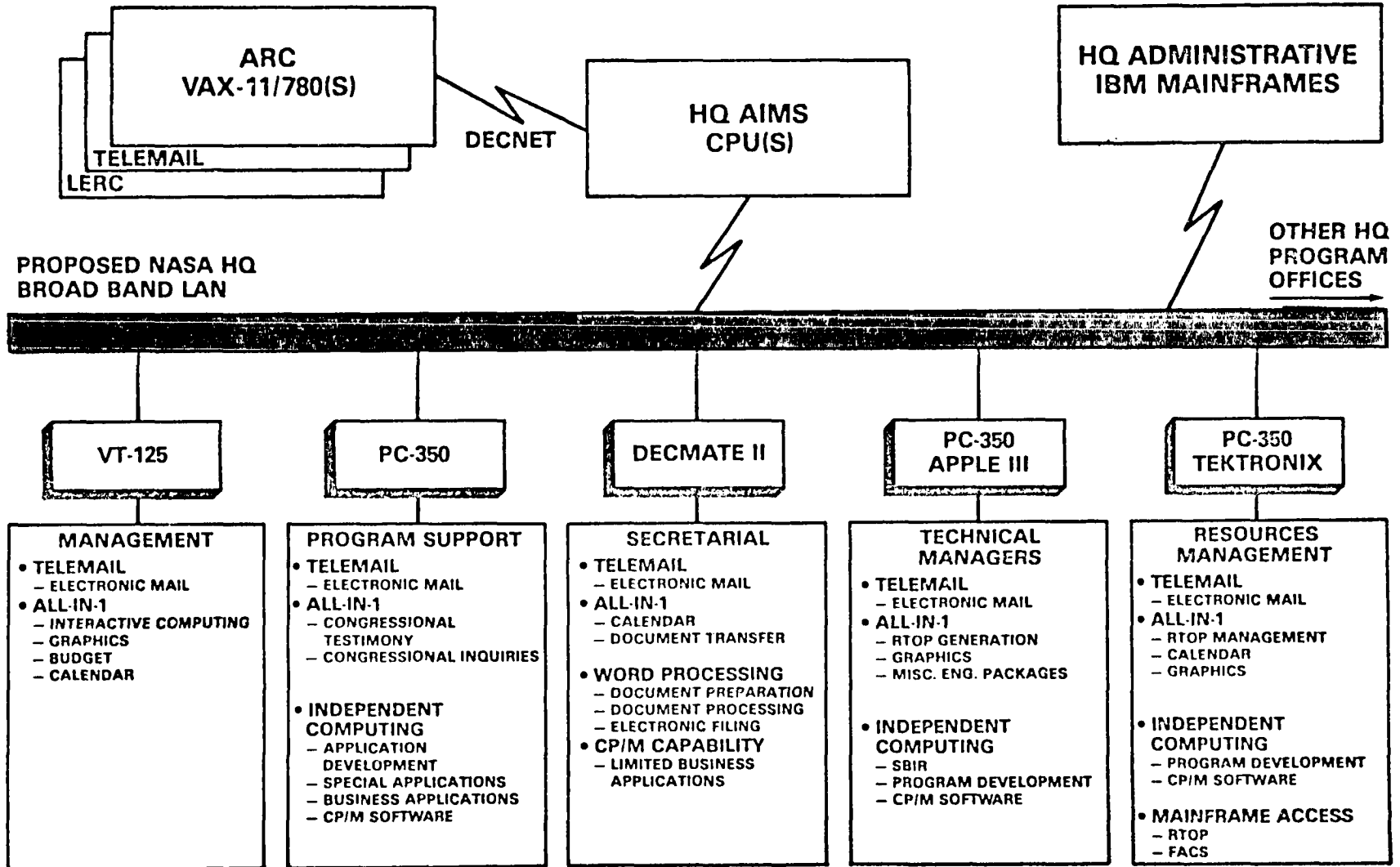

15

NASA

Figure 3-2. OAST Electronic Information Systems Network.

OAST HQS-RP13-1036(1) 1/16/83

FY 1983, FY 1984, FY 1985

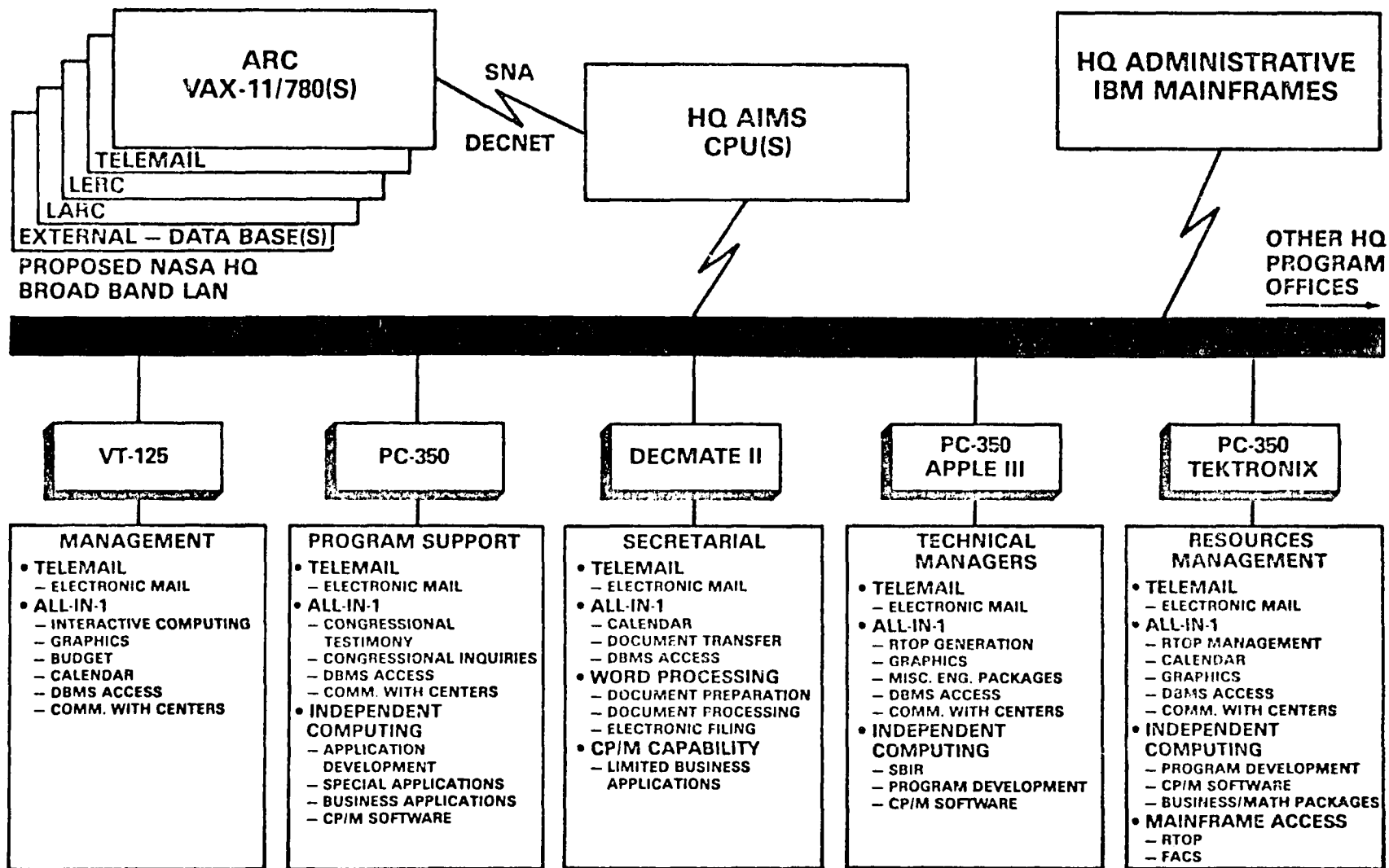

16

NASA

Figure 3-3. OAST Electronic Information Systems Network.

OAST HQS-RP83-1038(1) 1/16/83

COMPUTERIZED COVER SHEET AND RESOURCES FORMS
ELECTRONIC SIGNATURE AND TRANSMISSION
DATA-BASED INFORMATION SYSTEM
GRAPHICS
INTERCENTER COMMUNICATIONS
MANAGEMENT INFORMATION
TEXT EDITING

Figure 3-4. RTOP Automated System.

TAKES ADVANTAGE OF EXISTING HARDWARE, SOFTWARE, AND EXPERTISE

MINIMAL DEVELOPMENT TIME AND COSTS

-PROJECT INITIATION 9/82
-SYSTEM DEVELOPMENT 12/82
-FIRST TEST TRANSMISSION 3/83
-LIMITED SYSTEM 6/83

COORDINATED WITH HEADQUARTERS EFFORTS IN CODES R, E, AND T

Figure 3-5. Prototype System Development at Ames
Research Center.

USER INVOLVEMENT

....ALL PERSONNEL INCLUDING PROGRAM MANAGERS, MANAGEMENT
AND CLERICAL STAFF AT CENTER

....HEADQUARTERS BUDGET AND AIMS PROGRAM OFFICE REPRESENTATIVES

USE OF EXISTING COMPUTATIONAL EQUIPMENT

....VAX 780 COMPUTER CENTER AT ARC

....AIMS DEC EQUIPMENT AT HQS

COMPREHENSIVE APPROACH TOWARD RTOP SIMPLIFICATION AND STANDARDIZATION

....REVIEW OF ACTIVITIES

....MANAGEMENT INSTRUCTION

USE OF EXISTING SOFTWARE

....ALL-IN-ONE

....DEVELOPMENT EMPHASIS BY ON-BOARD CONTRACTOR SUPPORT

PILOT TESTING

....INVOLVES EVERYONE WILLING

....SHORT-TERM SCHEDULE

Figure 3-6. Approach.

4. RAMIS DBMS Update

James Head
Goddard Space Flight Center

I recently returned from a roundtable in Chicago of our DBMS. We had three and a half days of presentations, discussions and demonstrations. We had no less than six guest speakers, and I would like to share with you some of my notes on the topics germane to this presentation.

The first speaker, John F. Rockart, is Director, CISR, and Senior Lecturer of Management Science from the Sloan School of Management, M.I.T. He spoke on "Managing End-User Computing." John Gantz from International Data Corporation, of which Computerworld is a part, spoke on "IBM Strategies." Richard H. Cobb of Mathematica Products Group, our host for the roundtable, spoke on the "Evaluation of Fourth-Generation Languages." On a similar subject, Donald G. Ross of Database Research Group spoke on "Software Innovation, New Directions."

John F. Rockart had some eye-opening statistics and observations derived from an in-depth study of 271 organizations, most of which were in the Fortune 1000. Since his talk lasted an hour and a half and summarized the study, I will make a few observations only. The first three slides represent where we've been as an industry.

Figure 4-1.

The first chart is the traditional "Fast Calculator" application. It is almost always an accounting function (usually payroll) repetitive and unchanging.

COBOL, in this era, was a new tool destined to free the programmer from machine languages. The programming staff would now have plenty of time to expand systems into other areas.

Figure 4-2.

The highlights of the 1960s include the decentralization of computing facilities. Distributed processing was the buzzword. Minis began to appear.

Figure 4-3.

With the advent of large and powerful hardware combined with generalized software for applications development we saw a resurgence of centralized computing. It was the beginning of the DBMS. It was a rush into areas where angels fear to tread.

I don't think that there is anything surprising in any of these first three slides, but Rockart's observations of the 1980s are rather interesting. The growth rate in the 1950s and 1960s was generally in the 15 to 20 percent bracket. In the 1970s and projected for the 1980s is a growth rate of 50 to 100 percent. This growth rate is predicated on the availability of a user-friendly DBMS. In fact, if you have had a DBMS installed for five years or more, the projection will approach 75 percent.

Programming in the 1980s can be broken into six major categories:

Figure 4-4.

Why this explosion in end-user programming?

- o Vastly improved end-user software
- o New generation of computers
- o Micros/PCs
- o Hardware costs down

- o User frustration/demand
- o Programmer availability
- o Availability of external data bases
- o Availability of internal data bases

Figure 4-5

Richard Cobb, President of Mathematica Products Group, spoke on the "Evaluation of Fourth-Generation Languages." He said that:

- o COBOL is not yet a dead language, but it is clear that it is dying .
- o Forty percent of all programming is being done by end-users in the leading companies.
- o Five percent end-user computing by the trailing companies .
- o By decade's end 75 percent of all computing will be done by 4GL.
- o Problem: 50 million office workers supported by 625,000 computer specialists.
Solution: teaching the computer to speak a language that is closer to the language that people use every day.

Mr. Cobb believes that we have gone through five evolutions of computer languages:

- o Machine language
- o Assembler language
- o Higher level languages (COBOL, FORTRAN, etc.)
- o Programming aids (DBMSs, report writers, etc.)
- o Nonprocedural languages

Some of the key points in defining a nonprocedural language include the following: "Taking the programmer out of the loops." This is a slight play on words. Assembler programs have an instruction register that controls the flow of a program. In COBOL the control register is still present but not directly controlled by the programmer. The order, or careful control of the loops, is still very much a requirement. The nonprocedural language removes this concern. For the fourth generation language to be truly effective, it must contain data base management capability as an integral component. The ones that prove most effective are the ones that respond interactively in the form of an ongoing dialog to the questions the user poses.

Ronald G. Ross of Database Research Group, Inc. continued the theme in his presentation: "Fourth Generation Languages: A Definition."

One interesting observation is that DP organizations are getting better in implementing applications and yet the backlog of applications is growing at a faster rate. Experts agree that a crisis exists in computer productivity, and most agree that the solution is to get end-users, as much as possible, into their own special processing. The tools may very well be available on today's market. Products like RAMIS, FOCUS, and INTELLECT provide the nonprocedural, user-friendly language necessary for this approach to the backlog dilemma.

Ross presented 10 defining criteria for 4th generation languages.

Figure 4-6

I would like to take these 10 criteria and compare them to our DBMS, RAMIS.

Figure 4-7

Criteria

1. Result-oriented programming
 - o Nonprocedural language
 - o English-language processor
 - Did at least four customers order pumps in March?
 - How many units of each product have we sold?
 - Which customers purchased more than 5000 units?

The English Language Processor uses three dictionaries:

- o General dictionary of the English language
- o RAMIS II file dictionary
- o File Specific dictionary

Figure 4-8

2. Common Language/Demand Level Adaptability

- o Programmer and the user community speak a common language.
- o Numerous defaults for the end-user, program development tools for application development.
- o Macros and menus for the end user.
- o Formatted screens: define executive functions for the experienced programmer.

Figure 4-9

3. Application Expansion

- o Growth in capability
- o Growth in usage
- o The "Relate" component allows access RAMIS, QSAM, VSAM, ADABAS and other file structures to be combined for information processing.
- o RPI allows access via COBOL, FORTRAN, Assembler, etc.
- o Concatenation of databases (up to 16)
- o Database Information System – Central Dictionary Component

4. User/Machine Insulation

RAMIS offers complete portability between different system environments. For example, a RAMIS II application running under CICS with 3380 disk drives could be transferred to another machine running TSO using 3330 disk drives with 2 commands – one command to unload the database and one command to reload to the new environment.

5. Work Station Environment

The ability to store current tasks and recall them with ease is an important requirement in the work station environment. In addition, the capability of building onto existing prior efforts, or incorporating standard routines into the current process is vital in the development process. RAMIS II solves this problem with a number of features. In the interactive environment, procedures can be stored via a catalog command. RAMIS has its own editing capabilities called Interactive Request Modification Requests, which can be copied and merged on command.

Data files or requested subsets of files can be retained by the "HOLD" command, often called a "scratch pad." These files can become permanent files by requesting the "HOLD" file to be "ALTERED" to a permanent file. RAMIS will create the proper dictionary for the new file.

Figure 4-10

6. Comprehensive Software Toolkit

The RAMIS system has an excellent supply of software aids or features for the experienced programmer. For example REF provides an external file interface to sequential, ISAM, or VSAM files. In addition RAMIS can "TALK" to other DBMS files such as DL/1, TOTAL, IDMS, and ADABAS. The "RELATE" feature will combine any of these file types into a data base for reporting purposes or for permanent storage. RAMIS has a simple yet powerful high resolution graphics capability. A simple table request can turn into graphics with one command, i.e., "PLOT PIE."

7. Integrating Perspective on Computing and Data Resources.

Figure 4-11

For the end user or the non-data-processing user, the system must operate in a consistent and friendly fashion. Access to data must be the same regardless of how the data is stored. RAMIS provides this for the end user through its query language facility. A single access strategy is automatically provided for any query.

8. End User Data Base Capability

With the recent product announcement of "ENGLISH," RAMIS has joined "INTELLECT" in being the only two products based on artificial intelligence technology. RAMIS II English learns through the dialogue process. As the user responds to questions posed by English, the systems knowledge base is automatically and dynamically enriched, improving fluency.

The existing query language of RAMIS II is a very powerful tool for all users. With this announcement the product is as good as anything on the market today.

When you consider the relational capabilities, access to many varied file structures and high resolution graphics, all driven by an English-like language, you have a very powerful software tool regardless of the experience level of the end user.

9. Accessible Dictionaries

RAMIS II provides access to the dictionaries via canned queries. Users may write queries against any dictionaries since they are stored in a RAMIS II file.

RAMIS II also has a central repository of dictionary information available for use. This particular feature is another product of the system.

10. User Assistance/Facility Coordination

Figure 4-12

RAMIS II has a number of tools in this area, the most direct being a hot line in Mathematica called RAMIS Technical Assistance (RTA). Canned queries are also available. For example, the RAMHELP query is menu-driven to provide information, structure, and examples for most areas of their product. RAMERROR provides information about error conditions, and if possible, solutions to the problem.

RAMLEARN is a new product that assists the new user via computer dialogue. The computer will remember where the user stops for the day and will continue from that point. It will also allow the user to return to previous segments or the experienced user to browse for key points.

Figure 4-13

New features and product enhancements are also available as a RAMIS II data base and is menu-driven.

The 1980s will be a very interesting era. We have speech synthesizers on home computers now. By decade's end someone will surely have speech recognition as part of a DBMS.

I also see more intelligence in our end-user community in using this common language. We are communicating, and they are asking—not if, but when—we will have full screen capabilities and when graphics will be available. We are seeing demand "pull" rather than technology push. We now have the horse before the cart, and we had better be in the cart.

ERA	1950 s
APPLICATION	ACCOUNTING
HARDWARE	CENTRAL COMPUTER BATCH PROCESSING
I/S TOOLS	ASM, COBOL PROJECT MANAGEMENT CAPACITY MANAGEMENT
MANAGEMENT	LINE

Figure 4-1

ERA	1960 s
APPLICATIONS	OPERATIONS ORDER ENTRY MANUFACTURING CONTROLS
HARDWARE	DECENTRALIZED MINI'S ON-LINE
I/S TOOLS	COBOL PROJECT MANAGEMENT CAPACITY MANAGEMENT
MANAGEMENT	MATRIX

Figure 4-2

ERA	1970 s
APPLICATION	INFORMATION DECISION SUPPORT SYSTEMS EXECUTIVE SUPPORT SYSTEMS COMPUTER CONFERENCING END-USER COMPUTING ELECTRONIC MAIL
HARDWARE	CENTRAL & DECENTRALIZED ON-LINE
I/S TOOLS	DATA BASE MANAGEMENT SYSTEMS RAMIS, FOCUS, ADABAS
I/S MANAGEMENT	MATRIX STAFF SUPPORT

Figure 4-3

1. NON PROGRAMMING END-USER
 - o MENU
2. UNSOPHISTICATED
 - o HIGH LEVEL USER FRIENDLY
3. END-USER PROGRAMMER
 - o SOLVING OWN PROBLEMS
4. FUNCTIONAL PROGRAMMER
 - o SOPHISTICATED USER
 - o SUPPORT PERSONNEL
 - o ONE OF A GROUP
5. CENTRALIZED END-USER COMPUTING SUPPORT
 - o INFORMATION SUPPORT
 - o SMALL DEDICATED GROUP
 - o USER ASSISTANCE
6. TRADITIONAL I/S SUPPORT

Figure 4-4

END-USER DEVELOPMENT	
o INTERDEPARTMENTAL	15%
o DEPARTMENTAL	52%
o PERSONAL	32%
SOURCES OF DATA	
PRODUCTION SYSTEMS	36%
KEYED FROM REPORTS	31%
USER GENERATED	17%
PROCESS CONTROL	4%
OTHER	12%
FREQUENCY OF USE	
DAILY	6%
WEEKLY	12%
MONTHLY	10%
AS REQUIRED	66%
ONE SHOT	6%
NON-PROGRAMMER END-USER	55%

Figure 4-5

- o RESULT-ORIENTED PROGRAMMING
- o COMMON LANGUAGE/DEMAND LEVEL ADAPTABILITY
- o APPLICATION EXPANSION
- o USER/MACHINE INSULATION
- o WORKSTATION ENVIRONMENT
- o COMPREHENSIVE SOFTWARE TOOLKIT
- o INTEGRATING PERSPECTIVE ON COMPUTING AND DATA RESOURCES
- o END-USER DATABASE CAPABILITY
- o ACCESSIBLE DICTIONARIES
- o USER ASSISTANCE/FACILITY COORDINATION

Figure 4-6. Ten Defining Criteria for Fourth Generation Languages.

```

table
file pe-active
count entries and row-total and column-total across skl1 by dir
STATEMENT ERROR ... TYPE RP0140
AKL1
ACTION?(QUIT,CHANGE,FROM,REPLACE,EDIT)
skl1
COUNT ENTRIES AND ROW-TOTAL AND COLUMN-TOTAL ACROSS SKL1 BY DIR
end
  RP0808: NUMBER OF RECORDS IN TABLE=   3948  LINES=   10
  PAGE
  1
    SKL1
    100    200    300    500    600    700    900
  DIR  COUNT  COUNT  COUNT  COUNT  COUNT  COUNT  COUNT  TOTAL
-----
  000      8      0     120     32     20      80      0     260
  100      0      4      0      70     62      6      0     142
  200     150     20     161     198    339     22      2     892
  300      0      0      21     10      5      80      0     116
  400      0      3      3      48     91     194      0     339
  500      0      2      12     32     26     155      0     227
***
  600      1      0      54     28     21     207      0     311
  700      0      1     246     49     30     422      0     748
  800      0      1      31     55    116     218      0     421
  900      1      4      40     56     37     354      0     492
  TOTAL
      160     35     688     578     747    1738      2    3948
  >

```

Figure 4-7

```

USE
DATABASE
CODEPRC
END
OFFLINE
EXEC DBADEFINE 304
END
TABLE
RIGHT-JUSTIFY
'DATA BASE ADMINISTRATION REPORT: DBA05'
' '
CENTER
'* * * * * DAILY & WEEKLY PRODUCTION DATA SETS * * * * * '
' '
CENTER'
'FOR !PACK-USE! PACK: !VSI  MOUNT IS: !MOUNT!  BACKUP IS: !BACKUP!'
' '
FOOTNOTE
CENTER
'DATA BASE AS OF OCTOBER 31, 1981'
FILE DBA
SPACE 1
SUM SID AS 'SYSTEM, ID' AND FREQUENCY AND TA AS 'TRACKS, ALLOCATED'
AND ATU AS 'TRACKS, USED' AND ATF AS 'EXCESS, TRACKS'
AND UC AS 'USE, COUNT' AND CD AS 'DATE, CREATED' AND LU AS 'LAST, USED'
AND AGE AND DSORG AND REASON
AND PACK-USE NO-PRINT AND MOUNT NO-PRINT AND BACKUP NO-PRINT
BY VS NO-PRINT PAGE-BREAK BY F NO-PRINT BY DSN AS 'DATA SET NAME'
ON F SUB-TOTAL
IF TYPE NE C
IF F EQ D OR W
END
RETYPE

```

Figure 4-8

```

RELATE
PROJECT JOBS USING EACH JOBNAME
BY EMPNUM
RUN
PROJECT LANGUAGES USING EACH LANGUAGE
BY EMPNUM
KEEP THE INTERSECTION NAMED JOBSKILLS1
WITHOUT COMBINATIONS
END

```

JOBSKILLS1

EMPNUM	JOBNAME	LANGUAGE
1001	ACCOUNTING SYSTEMS	RAMIS II
1056	INVENTORY SYSTEMS	COBOL
1056		RAMIS II
2634	ACCOUNTING SYSTEMS	RAMIS II
2634	FINANCIAL PLANNING	
3154	INVENTORY SYSTEMS	COBOL
3154	FINANCIAL PLANNING	RAMIS II
4231	FINANCIAL PLANNING	ASSEMBLER
4231		COBOL
4582	ACCOUNTING SYSTEMS	ASSEMBLER
4582	FINANCIAL PLANNING	PL/I
4582		RAMIS II
5000	FINANCIAL PLANNING	ASSEMBLER
5000		RAMIS II

Figure 4-9

ramhelp new

Section Menu for Release 83.1 of RAMIS II

- 1 Reporting Extensions
- 2 Formatted Screen Manager
- 3 RELATE
- 4 Automatic Interface to IDMS
- 5 Integrated Terminal Communications (ITC)
- 6 DataBase Information System (DBIS)
- 7 New Executive Features
- 8 VALIDATE Function
- 9 ICCF Procedure
- 10 RAMXEDIT Procedure
- 11 RAMOFFLK User Exit
- 12 Other New Features
- 13 Efficiency
- 14 Upward Compatibility in Release 83.1

Enter number for section desired; MAIN for main menu;
STOP to exit; or press enter key to redisplay section menu.

Figure 4-10

ERROR DESCRIPTION FOR DATABASE MGMT ERROR CODE DM0120 (64)

TEXT: ERROR IN VIRTUAL SEGMENT DESCRIPTION IN FILE 'FILENAME'
TEXT: AT FIELD F
ACTION: AN ERROR HAS BEEN DETECTED IN THE LINKAGE
ACTION: CHARACTERISTICS AS THEY RELATE TO THE ASSOCIATED
ACTION: FILE. ANY COMBINATION OF THE FOLLOWING CONDITIONS
ACTION: HAS BEEN DETECTED FOR THE FIELD SHOWN IN THE MESSAGE.
ACTION: 1. A KEY LEVEL IN THE CROSS LINK IS GREATER THAN
ACTION: THE DATA LEVEL.
ACTION: 2. THE NUMBER OF KEYS ON A GIVEN LEVEL IN THE
ACTION: ASSOCIATED FILE AS DEFINED BY THE CROSS LINK
ACTION: EXCEEDS THE NUMBER OF FIELDS IN THAT LEVEL.
ACTION: 3. THE NUMBER OF FIELDS SPECIFIED IN THE RAMKEY
ACTION: FOR THE ASSOC. FILE EXCEEDS THE NUMBER OF
ACTION: ENTRIES DEFINED IN THE CROSS LINK.
ACTION: 4. THE DATA LEVEL IN THE CROSS LINK IS GREATER THAN
ACTION: THE NUMBER OF LEVELS IN THE ASSOCIATED FILE.
ACTION: 5. AT LEAST ONE OF THE LEVEL SPECIFIED IN THE
ACTION: CROSS LINK FOR KEY OR DATA IS A VIRTUAL
ACTION: LEVEL IN THE ASSOC. FILE.
ACTION: 6. THE RAMASTER DICTIONARY DOES NOT CONTAIN A
ACTION: DESCRIPTION FOR THE ASSOCIATED FILE NAMED.
DM0316: MSGLEVEL OPTION SET AT 0

Figure 4-11

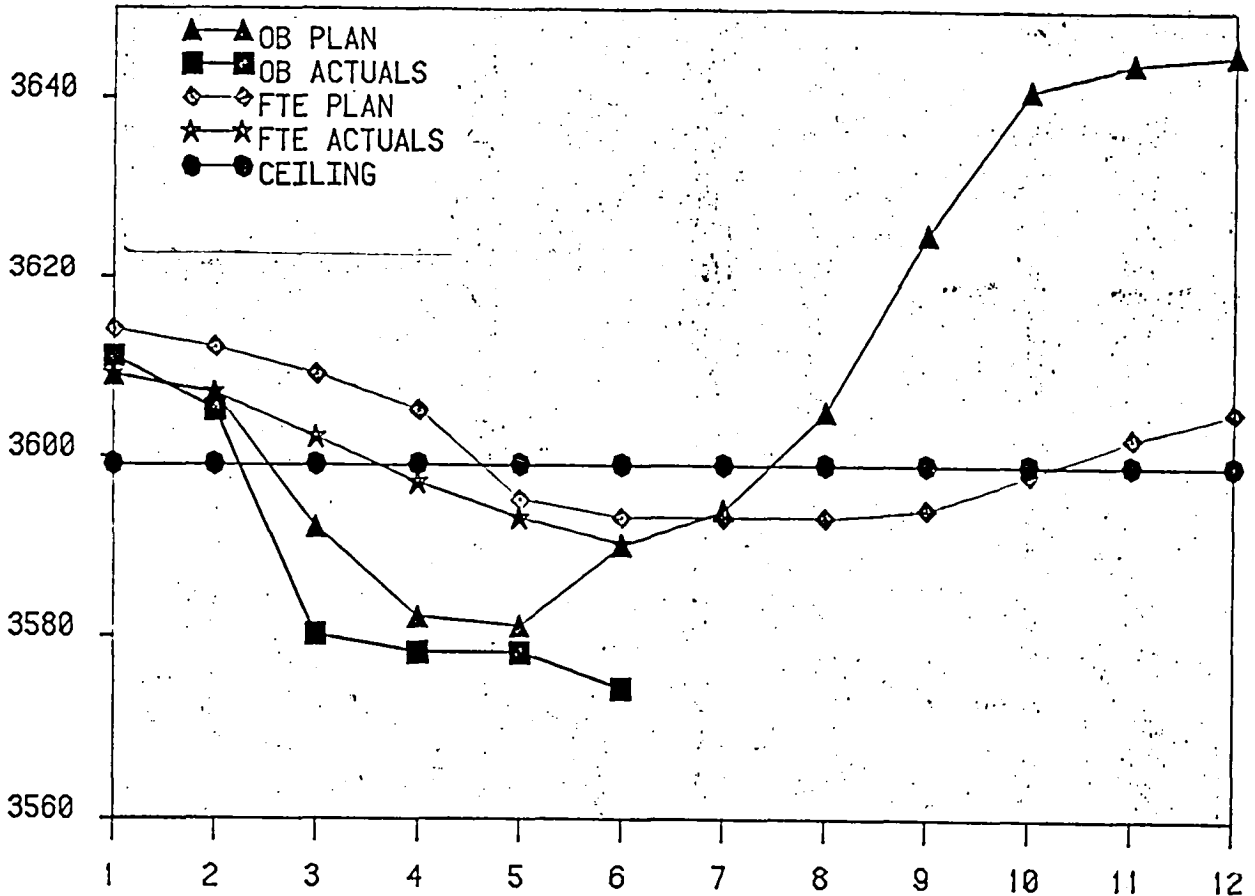

Figure 4-12. FTE Manpower, Center Summary.

THOUSANDS

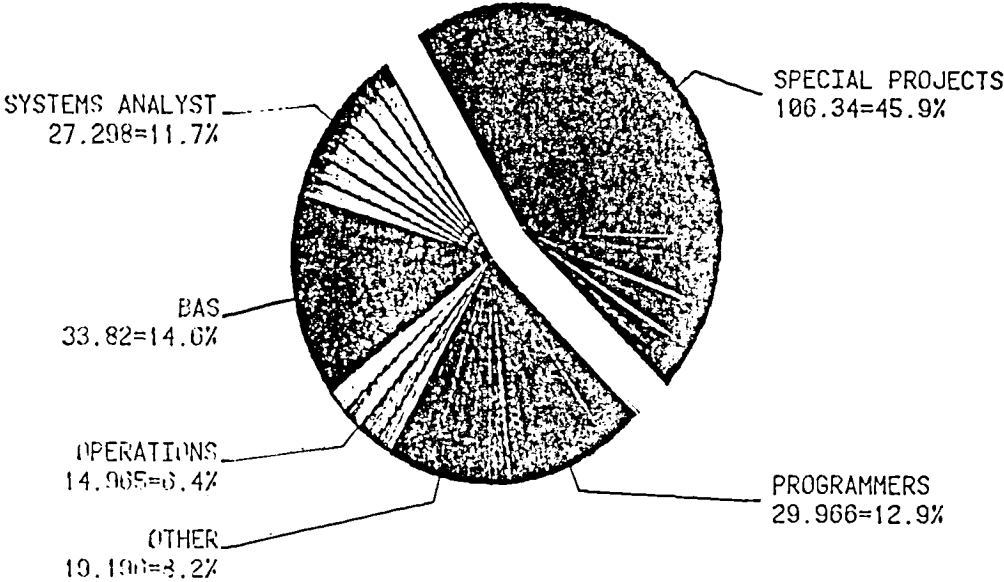

Figure 4-13. TSO Usage by Function.

5. INTERCENTER PROBLEM REPORTING AND
CORRECTIVE ACTION SYSTEM
(PRACAS)

Georgia H. Brock, NASA
James J. Paley, CSC
John F. Kennedy Space Center (KSC)

ABSTRACT

Accelerated launch schedules have magnified the need for rapid exchange of information concerning open problems and historical engineering data that contributes to problem resolution. The Kennedy Space Center has begun work to transform the PRACA Batch Automatic Data Processing (ADP) System of today into a fully integrated data base with on-line update and retrieval capabilities. The present manual system of reporting (Datafax, mail, and telephone) to the off-site design and engineering organizations will be replaced by direct access to the most current information as it accrues at KSC or VAFB. Two major goals of the Intercenter PRACA are to provide a single data depository for both launch sites and to fully integrate the problem data with engineering data as well as other relevant information. The resulting ADP system will provide a closed loop system for problem reporting, corrective action and recurrence control that should serve the engineering community as well as reliability and quality assurance at the launch sites, KSC and VAFB, and at the design centers, JSC and MSFC.

I. INTRODUCTION

The Level II Change Request S21701 charges KSC with the responsibility for conducting an optimum data system study to establish PRACA requirements for Space Transportation Systems (STS) Operations at JSC, MSFC, VAFB, and KSC. The study addresses the STS operational era needs of two-week orbiter turnaround and defines a phased transition from the era of STS Design, Development, Test, and Evaluation (DDT&E). Computer Sciences Corporation is conducting a top-down study which will define the intercenter PRACA development cycle up to the preliminary design phase of a structured systems development methodology. Upon completion of the study in August 1983, and resolution of any variances discovered during the review cycle in September 1983, the study will be offered for final review and acceptance by the Level II Space Shuttle Program Requirements Control Board in October 1983. This paper will include a definition of the PRACA discipline, the background and management of the ADP development, and the current and proposed

PRACA ADP Systems. The proposed system will be defined within the context of the Kennedy Data Management System (KDMS), the KSC-wide Information Management System, and broken into phases. The KSC system has been approved through implementation, but the Intercenter system is subject to approval by Level II prior to the detailed design phase. For this reason the schedules are coordinated but are kept separate.

II. THE PRACA DISCIPLINE

Problem Reporting and Corrective Action (PRACA) is one of the major functions of the STS Safety, Reliability and Quality Assurance (SR&QA) program. The discipline represents a structured system for the identification, analysis, correction, and prevention of recurrence of hardware and software nonconformances. A nonconformance reflects a condition of any article, material, or service where one or more characteristics do not conform to requirements due to a failure, discrepancy, defect, or malfunction. Nonconformances are generally categorized as problems or discrepancies. A problem is defined as any nonconformance that falls into category (a) or (b) as follows:

- (a) A failure or unsatisfactory condition that occurs during or subsequent to production acceptance testing.
- (b) A failure or unsatisfactory condition that occurs prior to acceptance testing that will or has the potential to adversely affect safety, contribute to schedule impact or launch delay, or result in a design change.

A discrepancy is a nonconformance that does not affect form, fit, or function; or that can be corrected by using previously approved instructions, and does not require recurrence control.

The life cycle of the PRACA process begins with the detection of a nonconformance, largely as a result of performing planned work activities, such as tests and operations, maintenance, inspections, assembly/disassembly, etc. Upon detection, the nonconformance is reported and documented in a prescribed manner. At KSC a standardized form (KSC 2-151) has been developed for reporting the three classifications of nonconformances. Prior to engineering analysis, the nonconformance is initially classified as an interim problem report (IPR). During analysis, using the criteria defined above, the final classification is either a Discrepancy Report (DR) or a Problem Report (PR).

Once analyzed and classified, the remedial action is delineated by the responsible engineer with instructions to accomplish the resolution. This action is referred to as a disposition and includes, in addition to instructions, a designation of the skill level of the personnel, and the material and facilities required to perform the work. Upon completion of all required tasks, the work is inspected by the responsible engineering and quality personnel and an approval is effected. At this point the nonconformance is closed and relegated to the historical information file.

With this oversimplification of the PRACA process, it is essential to highlight the three alternatives to the nonconformance resolution: (1) a local remedial action could completely resolve the condition, (2) a local remedial action which resolves the condition could warrant further action to prevent a recurrence of the condition (recurrence control), and (3) only recurrence control action could resolve the condition.

Recurrence control is a design engineering activity. It includes failure analysis and redesign when required. Recurrence control for Ground Support Equipment (GSE) is performed by engineering components at the launch sites. For flight equipment, it is performed within the various element contractors' organizations.

Figure 1 is a logical depiction of the PRACA System at KSC. The form numbers shown in the boxes relate to the standardized documents used at KSC. By way of clarification, KSC 2-151 is the document used to report and track Interim Problems, Problems, and Discrepancies. This document also serves as a work authorization document to perform remedial action tasks. KSC 2-155 is a continuation sheet for KSC 2-151. KSC 2-154 Corrective Action Assistance Request (CAAR) is employed when recurrence control is required.

PRACA is one of eight major functional disciplines that require data base management at the KSC and VAFB launch centers. While many of these functional disciplines are strongly interconnected, PRACA is directly related to (1) Mission Planning; (2) Work Control; (3) Safety, Reliability, and Quality Assurance; (4) Resource Management; (5) Operations and Maintenance Directives; (6) Facilities, Systems, and Equipment Management; and (7) Configuration Management. Figure 2 graphically depicts these relationships. By following uniform procedures, the quality assurance function ensures that each nonconformance is properly corrected by engineering and is approved. The process results in (1) a record of malfunctions traceable to individual parts and vendors, (2) a traceable link to the design engineering organizations when design

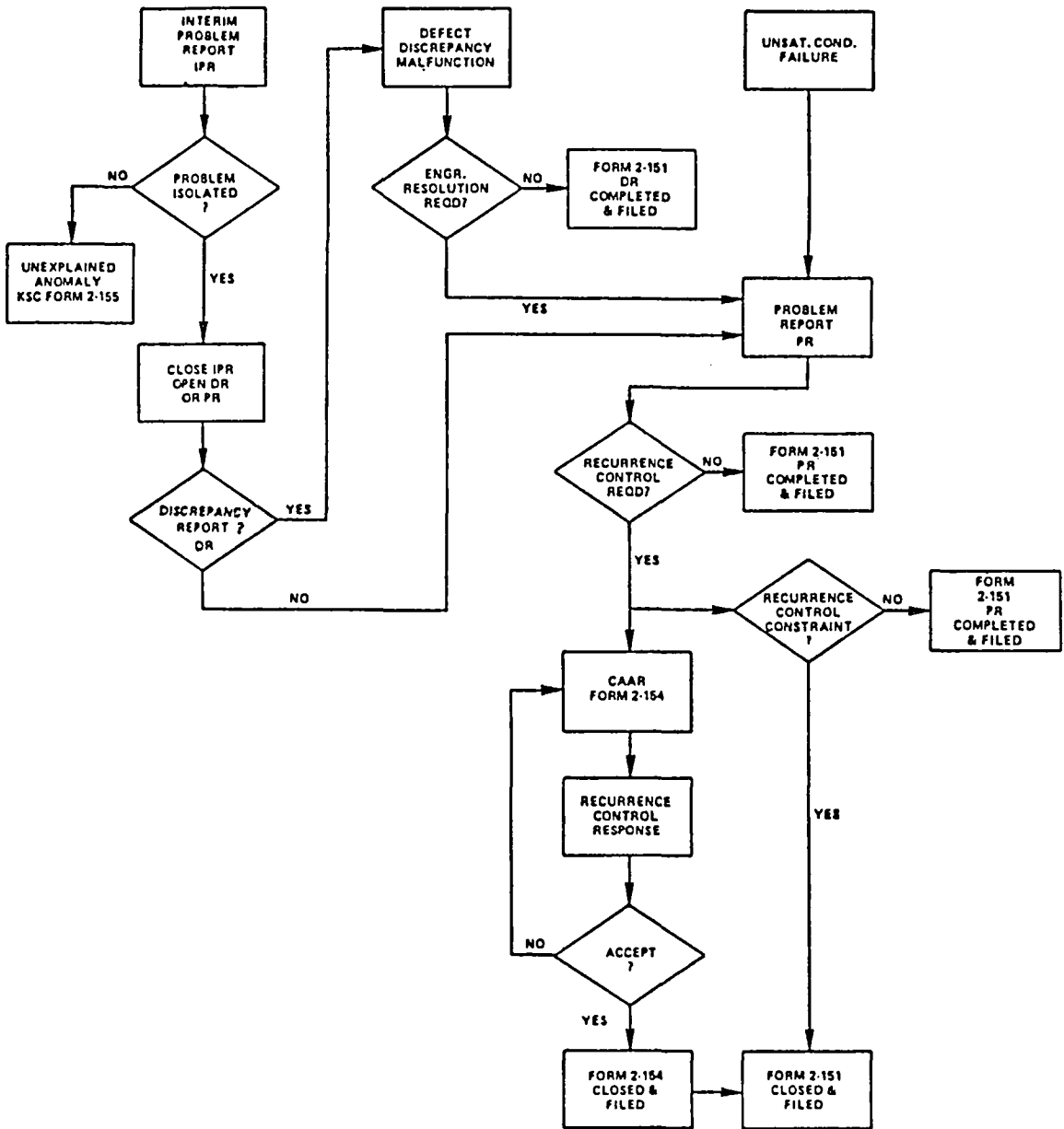

Figure 5-1. Nonconformance System Basic Logic Flow.

errors are suspected, (3) a trail of well-documented solutions - some by trial and error, (4) a central repository of detailed information about open problems that must be worked, and (5) a central repository of closed problems that provide trends and statistics for recurrence control activities.

The information in the PRACA data base is useful to engineers concerned with operations, design, safety, and reliability and to managers concerned with various levels of the engineering disciplines and quality assurance. The technical problem report analysis is concerned with documentation, remedial action, recurrence control, failure analysis, and hardware disposition while the management problem analysis is concerned with visibility, status, and decision support. For instance, an engineer looking for a solution to an open problem can query the PRACA data base for prior occurrences and solutions of the problem; his manager can status open problems for work planning activities; and the quality assurance inspector can ascertain system reliability. Key data elements can be combined into well-formatted reports to serve a variety of purposes within the PRACA discipline and reports from the various systems can be combined to analyze data across disciplines. This necessity to combine data across disciplines by manual methods emphasizes the requirement for a fully automated system that integrates information electronically.

The addition of the intercenter requirements to the KSC system will serve to close the loop in tracking a nonconformance from the time of detection through the remove and replace cycle and on to the resolution and recurrence control. The KSC PRACAS has always been a closed loop problem reporting and corrective action system for ground support equipment (GSE), but for flight elements, the problem report is sent to the JSC and MSFC design centers and their element contractors where the problem tracking, analysis, and resolution task is performed independently of the KSC PRACA System. With the intercenter requirements, the system will become a uniform closed loop system for all flight, ground support equipment (GSE), and government furnished equipment (GFE; i.e., space suits, manned maneuvering device, etc.). The PRACA intercenter relationships are shown in Figure 3.

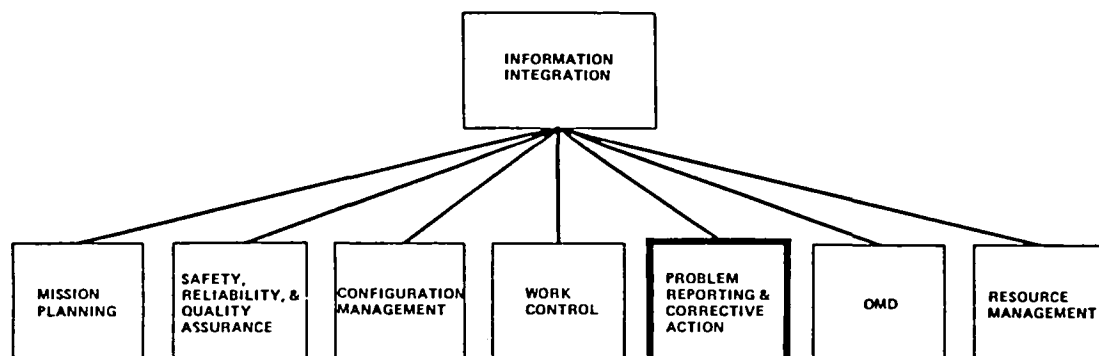

Figure 5-2. PRACA Functional Perspective.

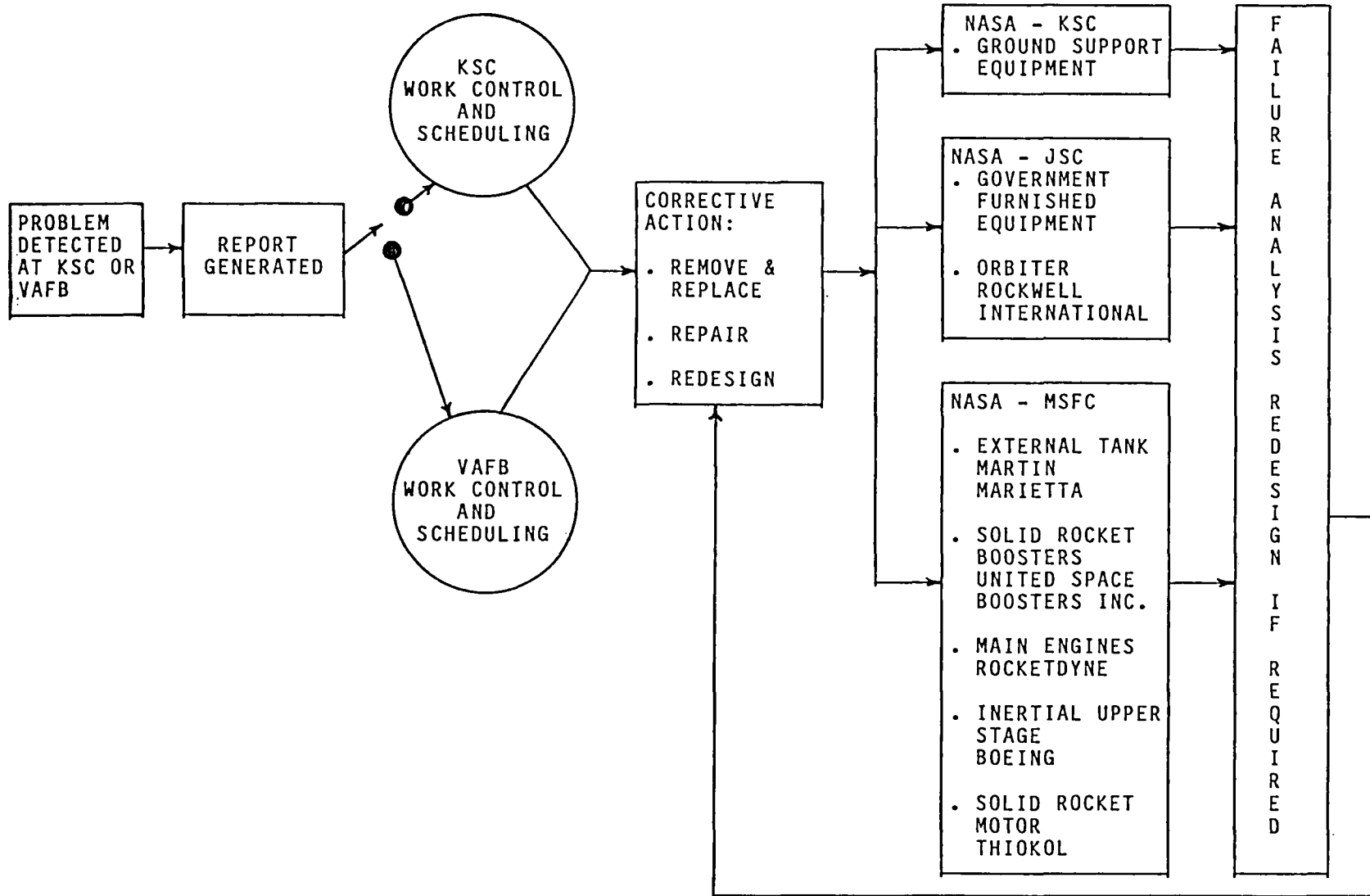

Figure 5-3. Uniform Closed Loop PRACAS.

III. BACKGROUND AND MANAGEMENT OF THE INTERCENTER OPTIMUM DATA SYSTEMS STUDY

The genesis of the intercenter PRACA Optimum Data Study dates back to 1980. At that time JSC, under the direction of NASA Headquarters, conducted a study to determine the functional requirements of the PRACA discipline in the operational era of the STS Program. In the following year, a series of meetings was held to analyze this basic information and to refine the requirements. NASA Headquarters, JSC, MSFC, VAFB, and KSC were represented in these discussions. As an outgrowth of these meetings, it became evident that due to the time constraints of the STS operational era, the centers would need to share the PRACA information efficiently in order to support accelerated operations and a broadened management decisionmaking process. It is the major goal of the Optimum Data Systems Study to determine the most effective means to provide this capability.

KSC has been designated as the NASA center with the responsibility for conducting the study. As the major launch site, KSC has broad horizons in the PRACA discipline. These include reporting and recording all nonconformances detected during launch processing of the flight hardware and software systems as well as ground support equipment. Further, there is a detailed interest and involvement in all nonconformances that occur at KSC, and there is responsibility for transferring and exchanging open item data with VAFB on shared orbiter and common facilities and ground support equipment. Moreover, KSC has the recurrence control functional responsibility for all ground support equipment at both KSC and VAFB.

KSC is currently defining the requirements for a significantly upgraded KSC PRACA ADP capability to become operational in December 1983. This system could become an integral component of any proposed intercenter system. The functional capabilities to be provided will be determined within the study.

KSC will coordinate requirements definition and direct ADP system development while JSC, MSFC, VAFB, and KSC representatives provide requirements and review/approve specifications. The direction of the intercenter PRACA system requirements development is stratified into two levels of guidance. The PRACA Working Group at KSC provides the direction for the KSC on-line ADP system development and advice for intercenter development methodology. A program-wide steering committee with representatives from each center regulates the course of NASA and USAF priorities and requirements for the intercenter PRACA ADP System. The Intercenter Steering Committee reports to the Level II IMS Panel at JSC.

Various provisions have been made for monitoring the progress of the CSC software development team. The KSC PRACA Working Group as a whole or key representatives of the group meet with CSC weekly for joint working sessions to define requirements, or to name key field representatives for information gathering or to discuss organization, methodology, status, or management of the project. There is also an informal status briefing for the KDMS Manager at his weekly user group meeting. At each major milestone in the CSC Digital Systems Development Methodology (see Figure 4), a formal briefing is held for the KSC PRACA Working Group. On the intercenter level, the informal status reports will be forwarded via the telemail feature of the JSC Office Automation System and through conference calls to MSFC and VAFB. The formal briefings will be delivered through the Kennedy Management Information System, KMIS, which enables viewgraphs to be transmitted to JSC, MSFC, and VAFB as the presentation is made through the conference call network.

Reducing the cost of STS processing is a major program goal as we move into the fully operational era of two-week Shuttle turnaround. The centralized PRACAS serving KSC, VAFB, JSC and MSFC is projected to save time and money by reducing the existing manual interfaces and eliminating duplicate functions. A plan for tracking the cost benefits is in work at Level II. The budget expenditures for intercenter PRACAS are accounted for at KSC and will be combined with cost savings across centers to produce the bottom line cost reduction. Other significant cost savings might be realized if more complete and reliable data are available for analyzing failures. Failure analysis is often quite costly. The centralized data base will provide more accurate up-to-date information to support decisions for reducing the frequency of failure analysis. The same accurate up-to-date information will also support the total recurrence control function for increased STS reliability and cost effectiveness.

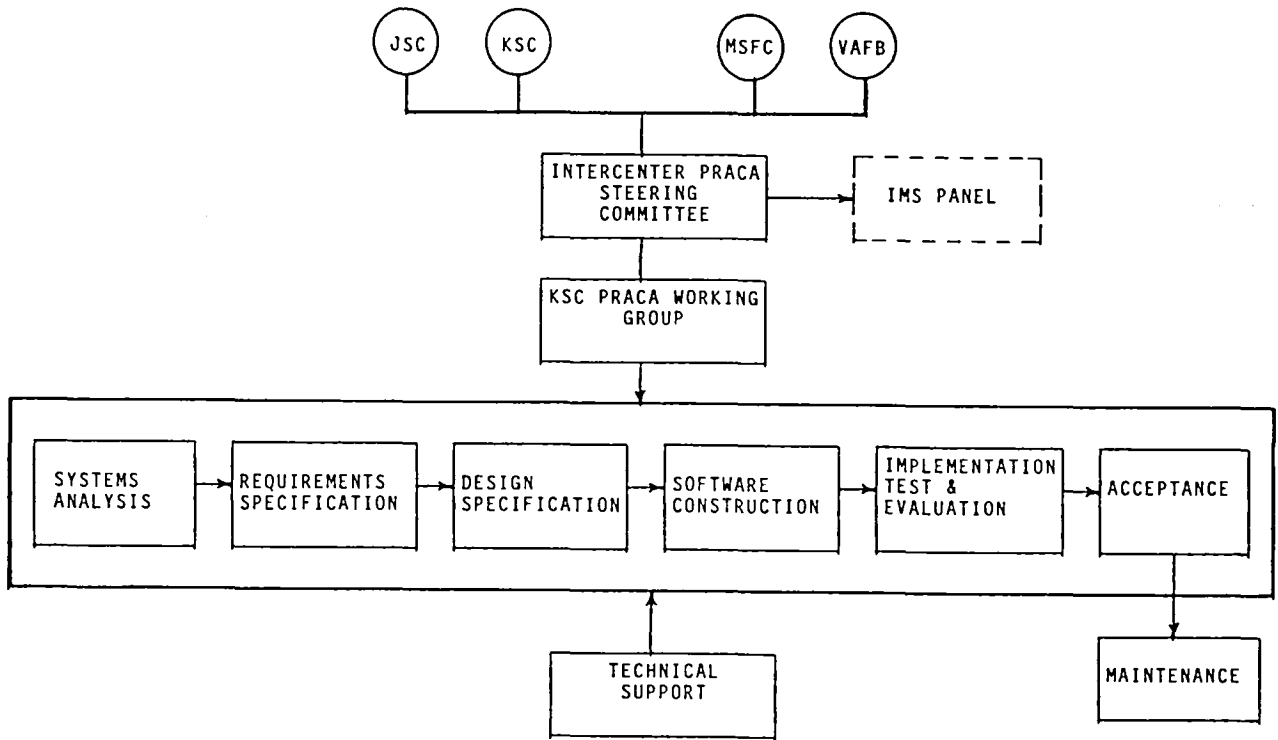

Figure 5-4. PRACA ADP System Development.

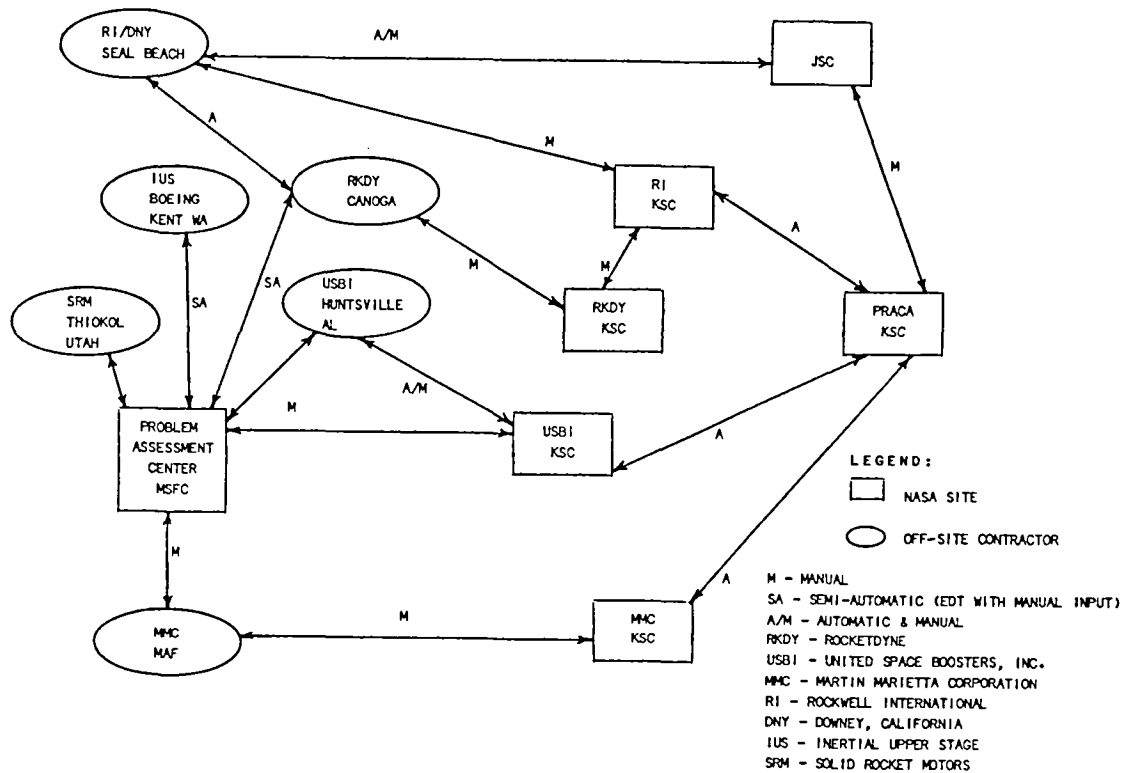

Figure 5-5. Current Shuttle Problem Reporting Interfaces.

IV. CURRENT INTERCENTER PRACAS FUNCTIONS

The day-to-day activities within the PRACA function are focused on the two broad areas of remedial action and corrective action. A remedial action can be an interim or final resolution to a nonconforming condition present in a system, an item, or a material. A corrective action which is directed toward prevention of a recurrence of a nonconformance is synonymous with recurrence control. Failure analysis and/or redesign constitute corrective actions.

At the program level, the remedial action function is preeminent at the launch centers (KSC/VAFB). Here the emphasis is on expeditiously resolving nonconformances discovered during launch processing relative to flight-or launch/flight-related equipment. If an identified nonconformance cannot be resolved or can be resolved on an interim basis only, a request for recurrence control is made. If it relates to ground support equipment, the request is transmitted to KSC Design Engineering. If it relates to flight hardware or software, it is transmitted to the local offices of the element contractors where it is then forwarded to their respective design engineering counterparts for action.

Monitoring and statusing of corrective actions by the element contractors is the responsibility of the safety, reliability, and quality assurance functions at JSC and MSFC. At JSC this responsibility includes the orbiter and government furnished equipment. At MSFC this includes the external tank, solid rocket booster, solid rocket motors, main engines, and inertial upper stage. The computer support at the two design centers varies. JSC utilizes a Control Data Corporation Cyber-74 computer for tracking and statusing open recurrence control problems at Rockwell International's Downey, California facility (orbiter) and at the various government furnished equipment vendor plants. MSFC utilizes an Alpha Micro Mini-computer to store the open problems at the Thiokol plant in Utah (solid rocket motor), the Boeing plant in Kent, Washington (inertial upper stage), the Rocketdyne facility in Canoga Park, California (main engines), the USBI facility in Huntsville, Alabama (solid rocket boosters), and the Martin Marietta Corporation's Michoud Assembly Facility (MAF) in Mississippi (external tank). Both centers receive data from the contractors in their unique formats which are edited and reformatted into the NASA data bases at JSC and MSFC. Some data from the contractors is sent electronically through communication networks, but at present, is not directly connected to either NASA data base. Gleaning the NASA-required data from the contractor's reports is largely a manual function that is difficult to automate. Figure 5 portrays the current program-wide interfaces. The data at the vendor sites is mostly computerized, utilizing vendor generated software systems that support non-STS work at the plant.

The KSC PRACAS operates on a Honeywell DPS-8 computer. On-line status and tracking of open problems is provided through the Automated Scheduling System. Open recurrence control problems and historical data are stored in the PRACAS data base weekly from time sharing collector files built by the quality organizations. Various batch reports spawned weekly or on demand provide open problem lists for operations and maintenance functions and for recurrence control on ground support equipment. Other batch reports provide visibility into trends that consider location of the failure, failed part numbers, vendors, and malfunction classifications. Ad hoc reports are available by request with one-day turnaround. Figure 6 represents the current batch PRACAS.

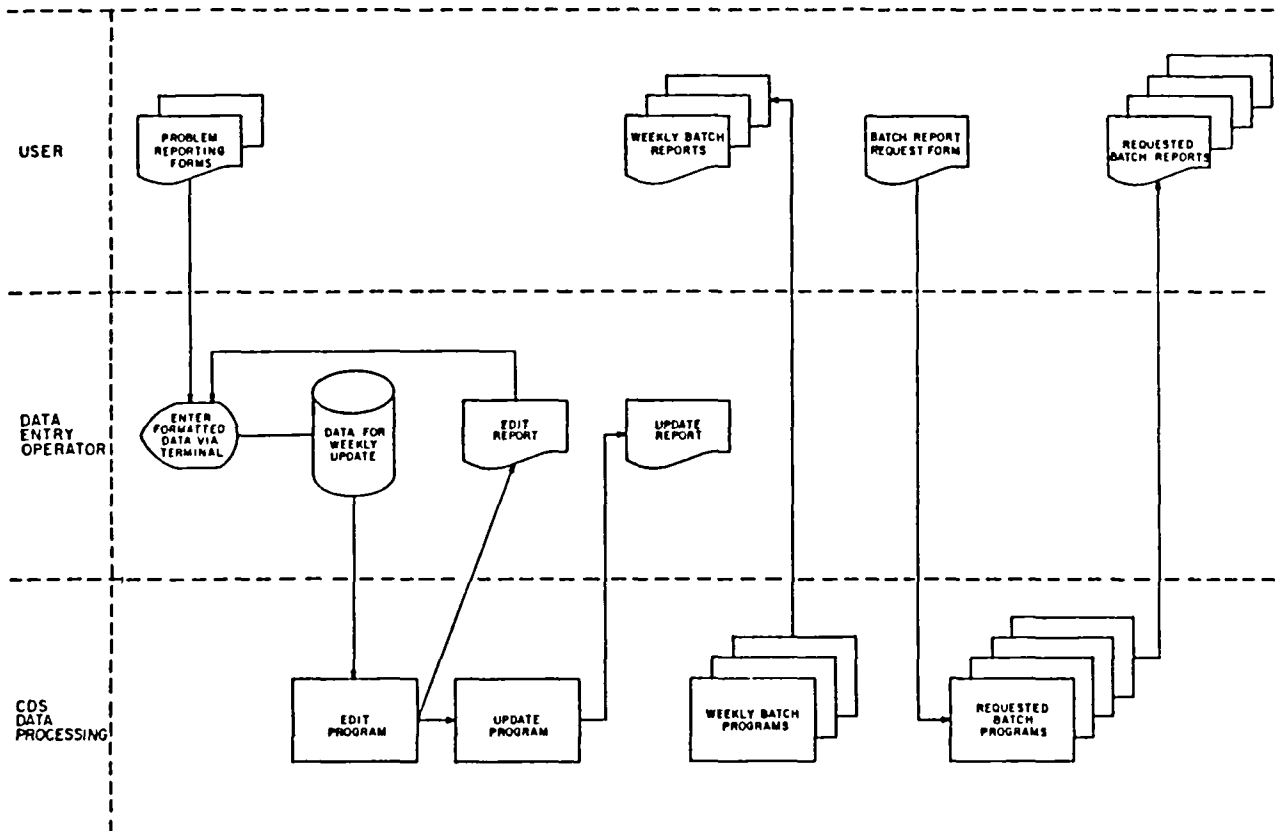

Figure 5-6. PRACA Current ADP Functional Flow Diagram.

V. THE PROPOSED KSC ON-LINE SYSTEM

The KSC PRACAS requirements are defined and are currently in the review cycle. The intercenter requirements are generally known but have not been fully analyzed and lack some detail. For these reasons, the KSC and intercenter system descriptions will be separated to provide for dissimilar levels of detail. The total integration of the KSC and intercenter requirements is planned, but the details are still in analysis.

A. The KSC On-Line System

The fully automated PRACA System depicted in Figure 7 will greatly reduce the need for paper flow and will improve the action required response time of organizations processing the nonconformance. The identified nonconformance will be entered into the PRACA data base immediately by a conveniently located terminal operator using easy forms mode. For inconvenient or restricted locations such as white rooms, the data are transmitted to the terminal operator by telephone or head set. Automatic notification begins once the data are entered. Once the responsible engineering office is determined and notified, the system will designate a qualified engineer to disposition the nonconformance. During troubleshooting, the engineer may require that certain steps from an Operations and Maintenance Instruction (OMI) be used to troubleshoot/disposition the nonconformance. By stating the OMI number and steps involved, the PRACA System can obtain the information from the OMI data base and include it as part of the disposition block. Upon completion of the disposition by the engineer, the quality organization identifies inspection points and if hazardous operations are involved, the safety organization identifies safety control. The work package will be completed with information obtained through the Automated Work Control System which will have interfaces to documented standard tasks, employee training and certification, configuration control and logistics. The work package will be directed to the appropriate work station, worked by the assigned technician, closed through PRACAS with automatic termination of the work control task accompanied by automatic notification of the appropriate personnel. If recurrence control is determined necessary, the appropriate design or sustaining engineering organization will be notified off site as well as at KSC. System security will provide for authorized approval and operations and maintenance statusing capability. If the problem report results in the generation of an Engineering Support Request, then the PRACAS will interface with the Modification Management System for tracking and statusing.

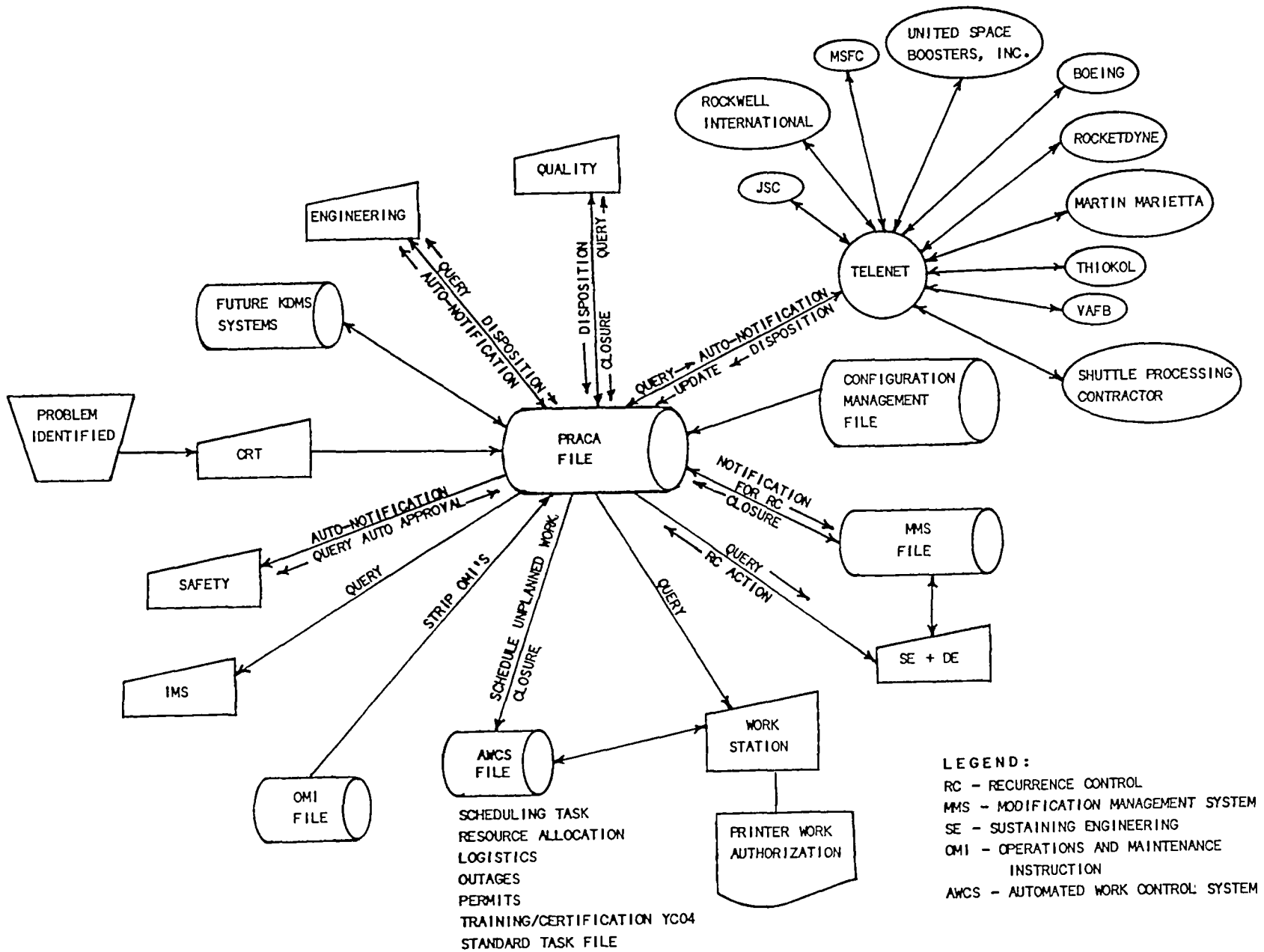

Figure 5-7. PRACA Conceptual ADP Functional Flow Diagram.

The fully automated PRACAS is an ambitious project depending on the future generation of automatic interfaces between currently stand-alone Kennedy Data Management Systems (KDMS), some on separate computers. Also, the intercenter requirements will not be fully defined until later this year. For these and other reasons, the implementation of PRACAS is defined as an initial phase (Phase I) and an open-ended continuation phase (Phase II) that must be correlated to the KDMS development cycle and revised to include intercenter requirements as they become available.

B. The Optimum Data Study for the Intercenter System

From the intercenter viewpoint, very generally, the objectives of the program are to track problems at the vendors that potentially impact missions and schedules, to track problems at the launch sites through remedial action, and to track all recurrence control failure analysis requests originating at the launch sites or the test facilities. The data and the structure of the flow of information is as follows.

The launch sites, KSC and VAFB, track all nonconformance interim problem reports, discrepancy reports, and problem reports. These reports are written against ground support equipment, government furnished equipment, and flight hardware and software. The design centers, JSC and MSFC track only those problems that require failure analysis for recurrence control. Ten percent of the problems at the launch sites require recurrence control with the remainder of requests for recurrence control originating at the test facilities. The recurrence control for the ground support equipment is managed at KSC by the Design Engineering Directorate. The recurrence control for the orbiter and government furnished equipment is managed by JSC, and the recurrence control for the solid rocket motors, main engines, external tank, inertial upper stage, and solid rocket boosters is managed by MSFC.

The information for tracking and statusing nonrecurrence control failures at KSC and VAFB will be in the KSC central data base and will be worked from reports obtained directly from data by people who are located at the launch sites. Although JSC and MSFC and their contractors require all of the data generated at KSC about problems requiring recurrence control, the data generated by the design center contractors and by the NASA problem assessment centers is new data requiring data elements that are different from the KSC/VAFB data elements. The recurrence control functions at JSC and MSFC are worked by centralized problem assessment centers that manage

the recurrence control performed by the element and government furnished equipment contractors and subcontractors. All problems that require recurrence control are of sufficient criticality to require detailed quality engineering assessment, detailed NASA engineering evaluation, and complete summary reporting to the responsible NASA management offices. It is not clear at this point in the intercenter PRACA requirements analysis whether some computerized data management should be provided at JSC and MSFC. The three choices for data base design are to have all data at KSC, provide for recurrence control data to be at JSC and MSFC, or to have the JSC recurrence control data at KSC and the MSFC recurrence control data at MSFC. Response time requirements, cost, and equipment availability at the design centers will be major factors in these decisions. MSFC already has some mini-computer support but the JSC hardware support will be discontinued by next year.

The KSC on-line system and the Optimum Data Study schedules are shown in Figures 8 and 9. The intercenter requirements, as defined in the Optimum Data Study, are subject to Level II approval prior to actual implementation; therefore the schedule does not extend beyond the review cycle.

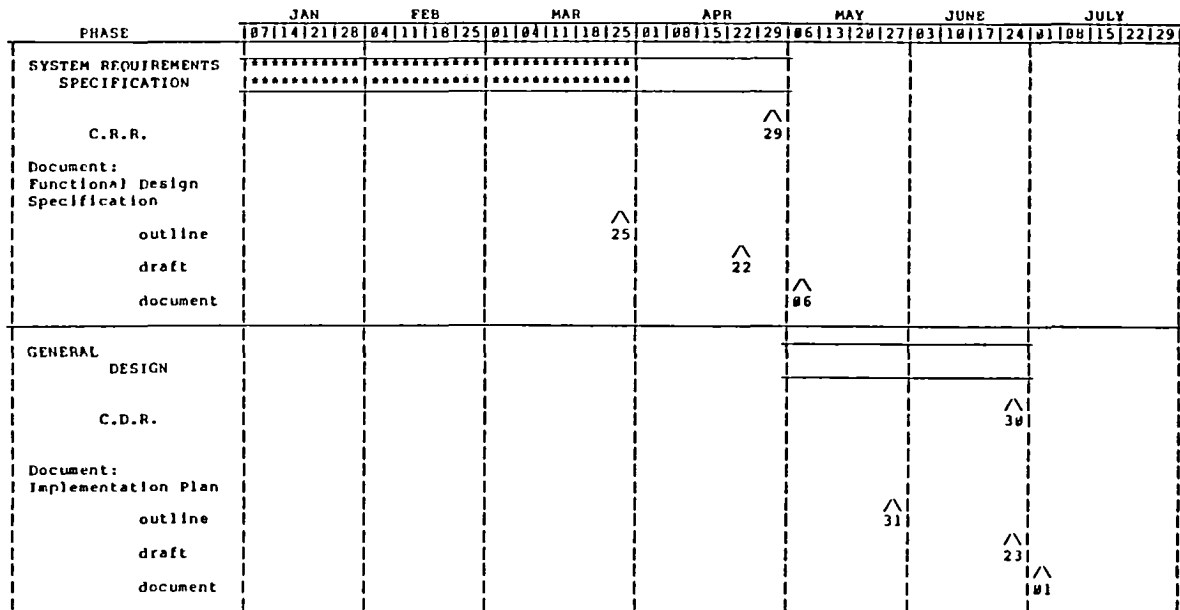

Figure 5-8. PRACA On-Line ADP System Development Schedule.

PHASE	1983																														
	JULY			AUG		SEPT		OCT		NOV		DEC		JAN																	
	01	08	15	22	29	05	12	19	26	02	09	16	23	30	07	14	21	28	04	11	18	25	02	09	16	23	30	06	13	20	27
DETAIL DESIGN																															
P.R.				^ 29		^ 26				^ 30		^ 21																			
Document: As-Built Specs.																															
outline																															
draft																															
document																															
SYSTEM INTEGRATION																															
I.T.																															
T.P.R.																															
U.A.T.																															
Documents: User's Guide																															
outline																															
draft																															
document																															
Operations & Maint. Manual and Validation Document																															
outline																															
draft																															
document																															

NOTES: ^ - Milestones
P.R. - Progress Review Review
I.T. - Integration Testing begins
T.P.R. - Test Progress Review
U.A.T. - User Acceptance Testing

The number appearing next to the Milestone indicates the completion or review date.

Figure 5-8. PRACA On-Line ADP System Development Schedule (Continued)

PHASE	1983																															
	MAR				APR				MAY				JUN				JULY				AUG				SEPT							
	01	08	15	22	01	08	15	22	05	12	19	26	03	10	17	24	01	08	15	22	05	12	19	26	02	09	16	23	01	08	15	22
SYSTEM REQUIREMENTS DEFINITION	*****																															
Site visits:																																
JSC																																
MSFC																																
VAFB																																
C.R.R.:																																
DESIGN CONCEPT																																
Reviews:																																
KSC Level III																																
MSFC Level III																																
VAFB																																
JSC Level II																																
Document: Recommended Implementation Plan																																
outline																																
draft																																
document																																

NOTES: ^ - Milestones
The number appearing under the milestone indicates the completion or review date.

C.R.P. - Critical Requirements Review
A list containing the requirements from all sites will be mailed out to each center by June 17.

Figure 5-9. Problem Data System-Optimum Data System Study Schedule.

PROGRAM OBJECTIVES

- o TO SUPPORT STS OPERATIONAL ERA TURNAROUND REQUIREMENTS.
- o TO REDUCE STS PROCESSING COSTS.

APPROACH

- o CENTRAL DATA DEPOSITORY.
- o ACCOMMODATION OF ENGINEERING REQUIREMENTS.
- o ACCOMMODATION OF RELIABILITY AND QUALITY ASSURANCE REQUIREMENTS.

Figure 5-10. Intercenter PRACAS.

- o PROBLEM REPORTING.
 - INTERIM PROBLEM REPORT.
 - DISCREPANCY REPORT.
 - PROBLEM REPORT.
- o CORRECTIVE ACTION.
 - REMEDIAL ACTION (LAUNCH SITES)
 - . REMOVE AND REPLACE.
 - . REPAIR.
 - RECURRENCE CONTROL (DESIGN CENTERS)
 - . FAILURE ANALYSIS.
 - . REDESIGN.
 - . REVISE PROCEDURES.

Figure 5-11. Intercenter PRACAS-The PRACA Discipline.

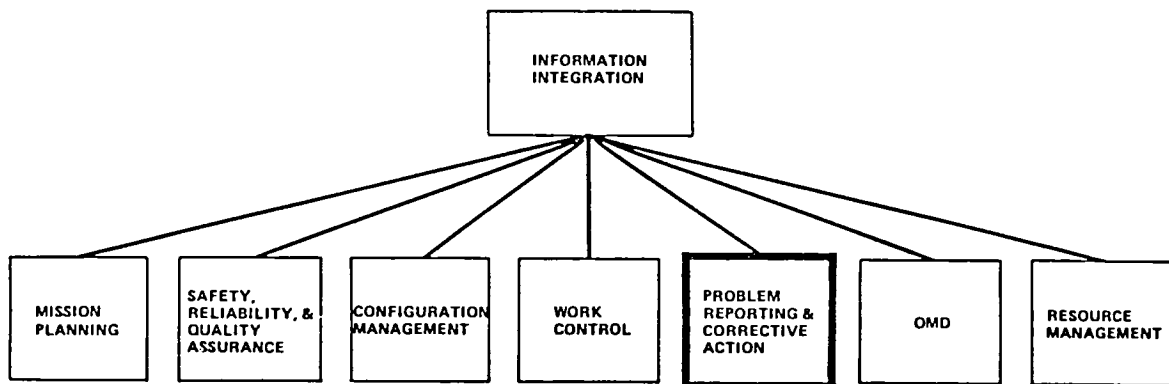

Figure 5-12. PRACA Functional Perspective.

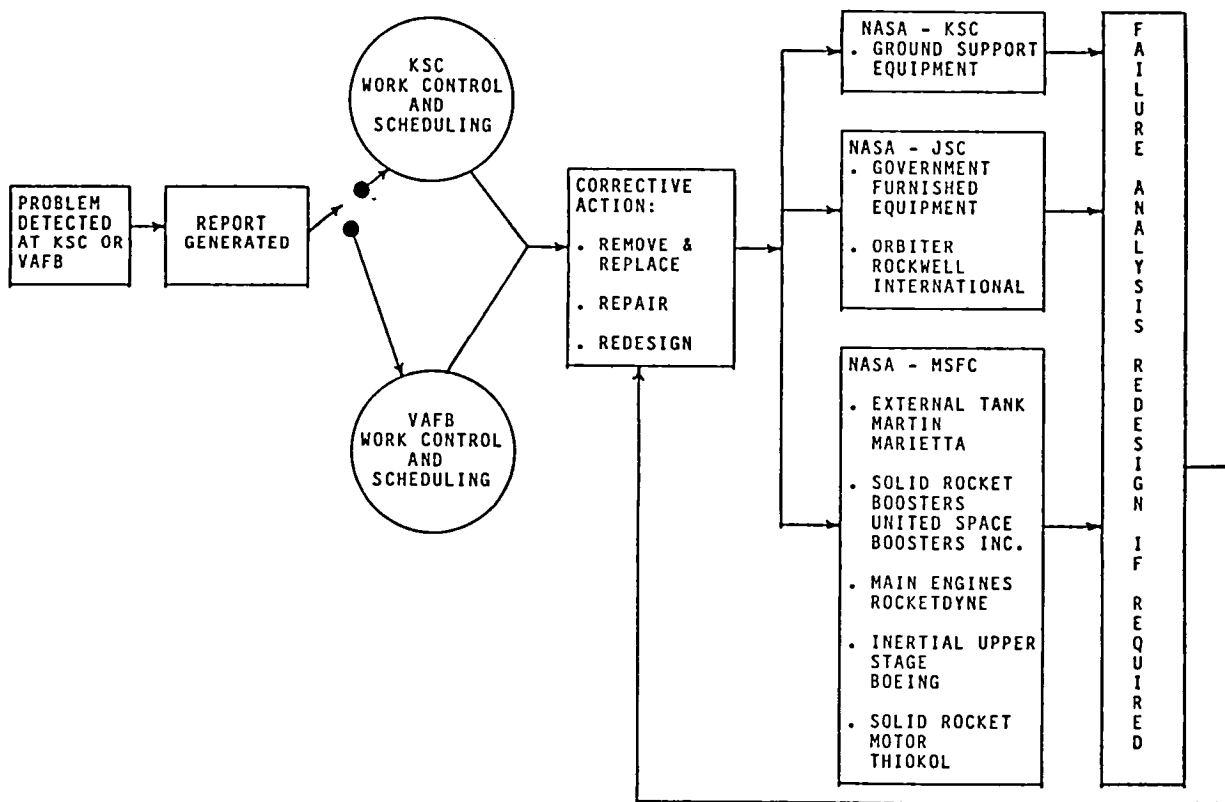

Figure 5-13. Uniform Closed Loop PRACAS.

- 1980 - NASA HEADQUARTERS DIRECTED JSC TO STUDY THE PRACA REQUIREMENTS FOR THE STS OPERATIONAL ERA.
- 1981 - INTERCENTER MEETINGS TO DISCUSS REQUIREMENTS.
- 1982 - EVALUATION OF SINGLE POINT DEVELOPMENT RESPONSIBILITY.
 - o KSC SELECTED.
 - REPORTS ALL NONCONFORMANCES.
 - TRANSFERS SHARED DATA.
 - HAS RECURRENCE CONTROL RESPONSIBILITY FOR GSE AT KSC AND VAFB.

Figure 5-14. Intercenter PRACAS-Background and Management.

RESPONSIBILITIES

- o KSC COORDINATES REQUIREMENTS SPECIFICATION AND DIRECTS SYSTEM DEVELOPMENT.
- o JSC, VAFB, AND KSC PROVIDE REQUIREMENTS AND REVIEW/APPROVE SPECIFICATIONS.

DIRECTION

- o KSC PRACA WORKING GROUP/INTERCENTER STEERING COMMITTEE.
 - COORDINATE DEVELOPMENT ACTIVITIES.
 - REVIEW PROGRESS.
 - RESOLVE PROBLEMS.

OBJECTIVE

- o DEFINE A PRACA ADP SYSTEM THAT WILL SATISFY THE PROBLEM REPORTING AND CORRECTIVE ACTION FUNCTIONS COMMON TO ALL STS PROGRAM CENTERS WITH EMPHASIS ON OPERATIONAL ERA TURNAROUND OBJECTIVES, RELIABILITY, AND COST EFFECTIVENESS.

Figure 5-14. Intercenter PRACAS-Background and Management (Continued).

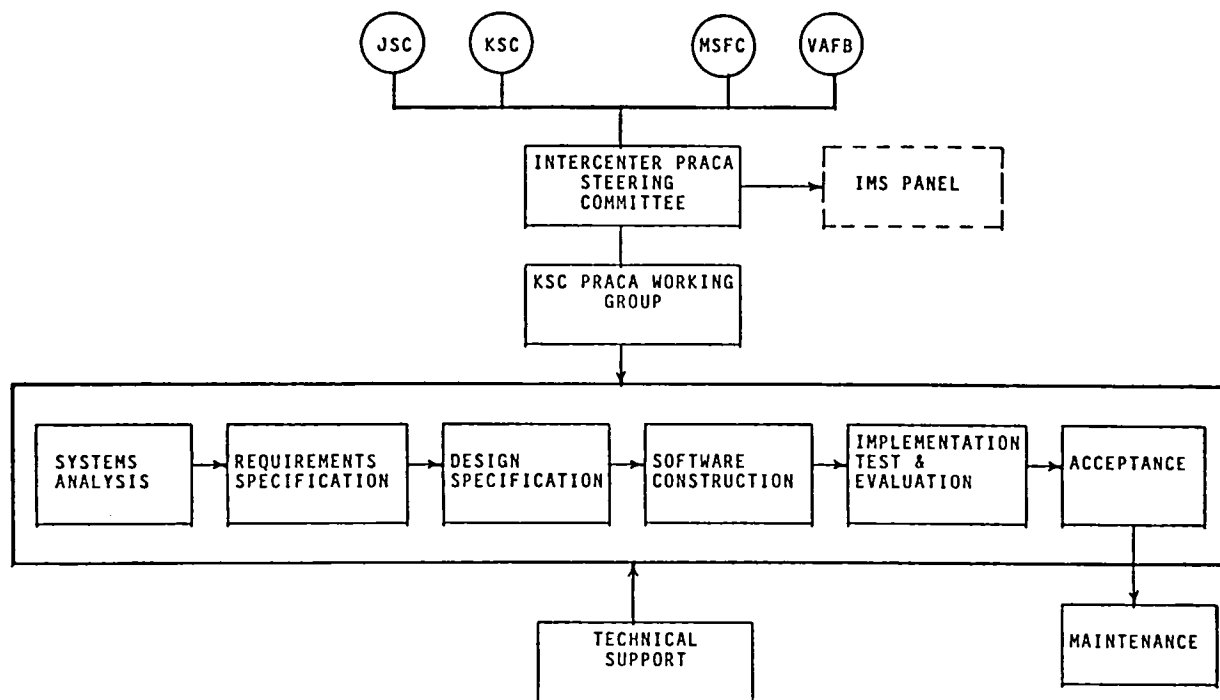

Figure 5-15. PRACA ADP System Development.

REMEDIAL ACTION

- o PERFORMED AT LAUNCH CENTERS (KSC/VAFB).
 - KSC PRACAS OPERATES ON HONEYWELL DPS-8 COMPUTER.
 - . OPEN PROBLEMS - ON-LINE STATUS PROVIDED BY SCHEDULING SYSTEM.
 - . CLOSED PROBLEMS - BATCH UPDATING AND REPORTING.

CORRECTIVE ACTION

- o PERFORMED AT DESIGN CENTERS (JSC/MSFC).
 - MSFC PRACAS OPERATES ON ALPHA MICRO MINI-COMPUTER.
 - WELL-DEVELOPED CENTRALIZED PROBLEM ASSESSMENT CENTER.
 - . CONTRACTOR CORRECTIVE ACTION REPORTS SENT TO MSFC BY MAIL, DATAFAX, OR COMMUNICATIONS NETWORK.
 - . MSFC MANUALLY GLEANS NASA REQUIRED DATA FROM CONTRACTOR'S REPORTS.
 - JSC PRACAS OPERATES ON CDC CYBER-74 COMPUTER.
 - . CENTRALIZED PROBLEM ASSESSMENT CENTER.
 - VERY SIMILAR IN FUNCTION TO THE MSFC PROBLEM ASSESSMENT CENTER.
 - PLANS TO PHASE OUT THE CDC CYBER-74 COMPUTER SUPPORT.

Figure 5-16. Intercenter PRACAS-Current Intercenter PRACAS Functions.

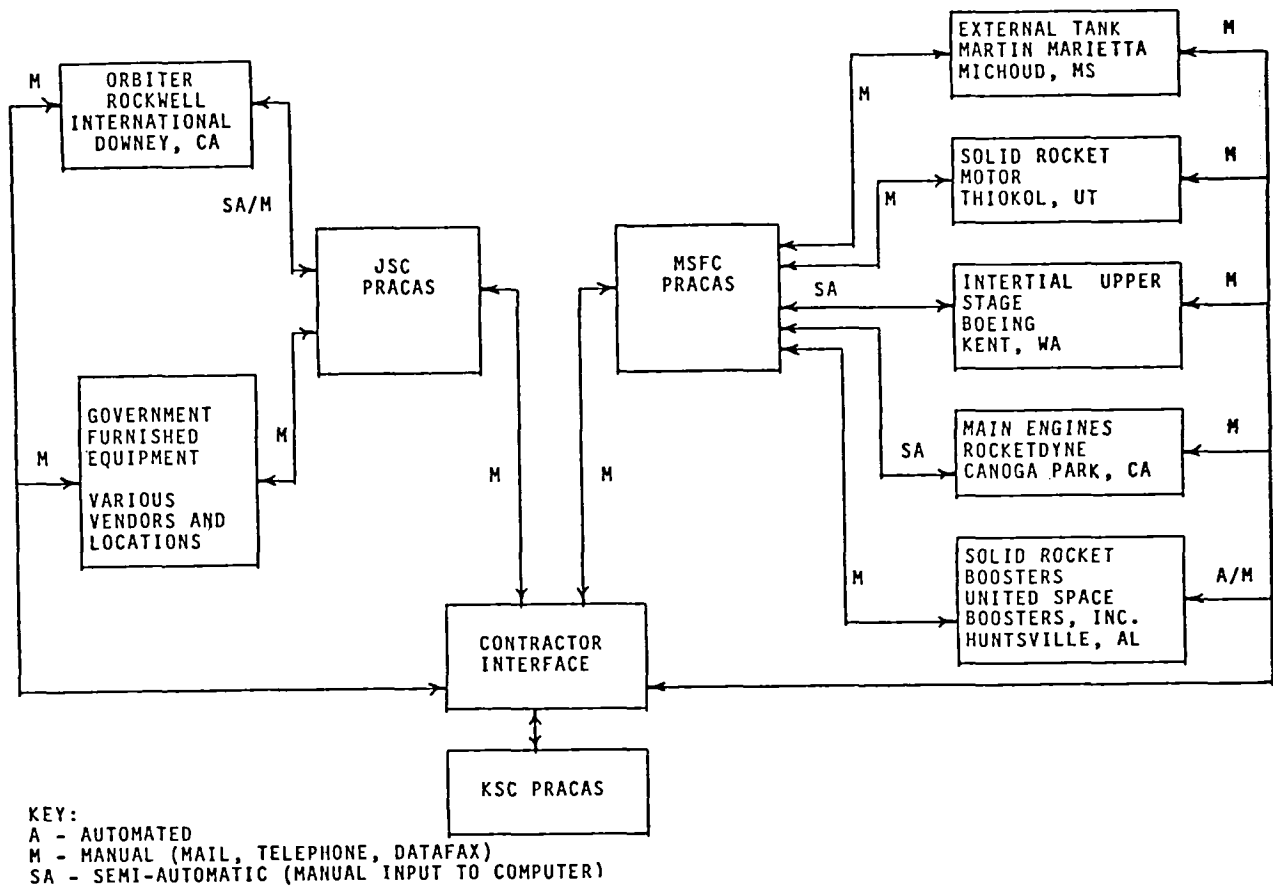

Figure 5-17. Current Problem Reporting Interfaces.

- o PRACA Is ESSENTIAL IN THE STS Ops ERA AT KSC/VAFB.
- o CURRENT BATCH PRACAS MUST BE UPGRADED TO MEET Ops ERA REQUIREMENTS.
- o A FULLY AUTOMATED PRACAS HAS BEEN DEFINED TO MEET KSC REQUIREMENTS.
 - FULLY AUTOMATED SYSTEM CONSTRAINTS.
 - . BUDGETS.
 - . KDMS DEVELOPMENT CYCLE.
 - . SHUTTLE PROCESSING CONTRACTOR.
 - TWO-PHASED IMPLEMENTATION.
 - . PHASE I - MAJOR UPGRADE TO KSC PRACAS BY DECEMBER 1983.
 - . PHASE II - OPEN-ENDED ENHANCEMENTS TO PHASE I CONFIGURATION.

Figure 5-18. Intercenter PRACAS-Proposed KSC On-Line System.

- o EXAMINE PRACA REQUIREMENTS AT A PROGRAM LEVEL.
 - SITE VISITS TO JSC, MSFC, AND VAFB COMPLETE.
 - ALL CENTERS TO REVIEW AND RESOLVE DIFFERENCES AT KSC JUNE 1 AND 2.
- o SPECIFY PRACA CAPABILITIES THAT SUPPORT ALL FOUR CENTERS.
 - CONSIDER OPS ERA TURNAROUND REQUIREMENTS.
 - CONSIDER RELIABILITY.
 - CONSIDER COST.
- o EVALUATE AND ADOPT MOST COST-EFFECTIVE STRATEGY.
 - UTILIZE EXISTING HARDWARE WHERE POSSIBLE.
 - INTEGRATE SYSTEM INTERFACES.
- o OPTIONS.
 - DATA BASE AT KSC WITH REMOTE TERMINAL/PRINTER ACCESS.
 - CENTRAL DATA BASE AT KSC WITH RECURRENCE CONTROL DATA BASES AT MSFC AND JSC.
 - CENTRAL DATA BASE AT KSC TO SERVE KSC, VAFB, AND JSC; RECURRENCE CONTROL DATA BASE AT MSFC.

Figure 5-19. Intercenter PRACAS-Proposed Intercenter PRACAS.

- o ON-LINE DATA ENTRY, UPDATE, AND RETRIEVAL.
- o USER FRIENDLY.
- o FLEXIBLE REPORT GENERATION.
- o MODULAR DESIGN.
- o CONTINGENCY RECOVERY.
- o SYSTEM CONTROL.
- o STATISTICAL ANALYSIS APPLICATIONS SOFTWARE.
- o FORMS MODE ENTRY.
- o HELP FUNCTION.
- o ON-LINE EDIT.
- o INTERACTIVE SEARCH AND RETRIEVAL.
- o MANAGEMENT INFORMATION REPORTS.
- o AUTOMATIC INTERFACE WITH KDMS.
- o EFFECTIVE CONSTRAINTS CONTROL.
- o AUTOMATIC NOTIFICATION.
- o MINIMAL USE OF PAPER.

Figure 5-20. Intercenter PRACAS-System Capabilities.

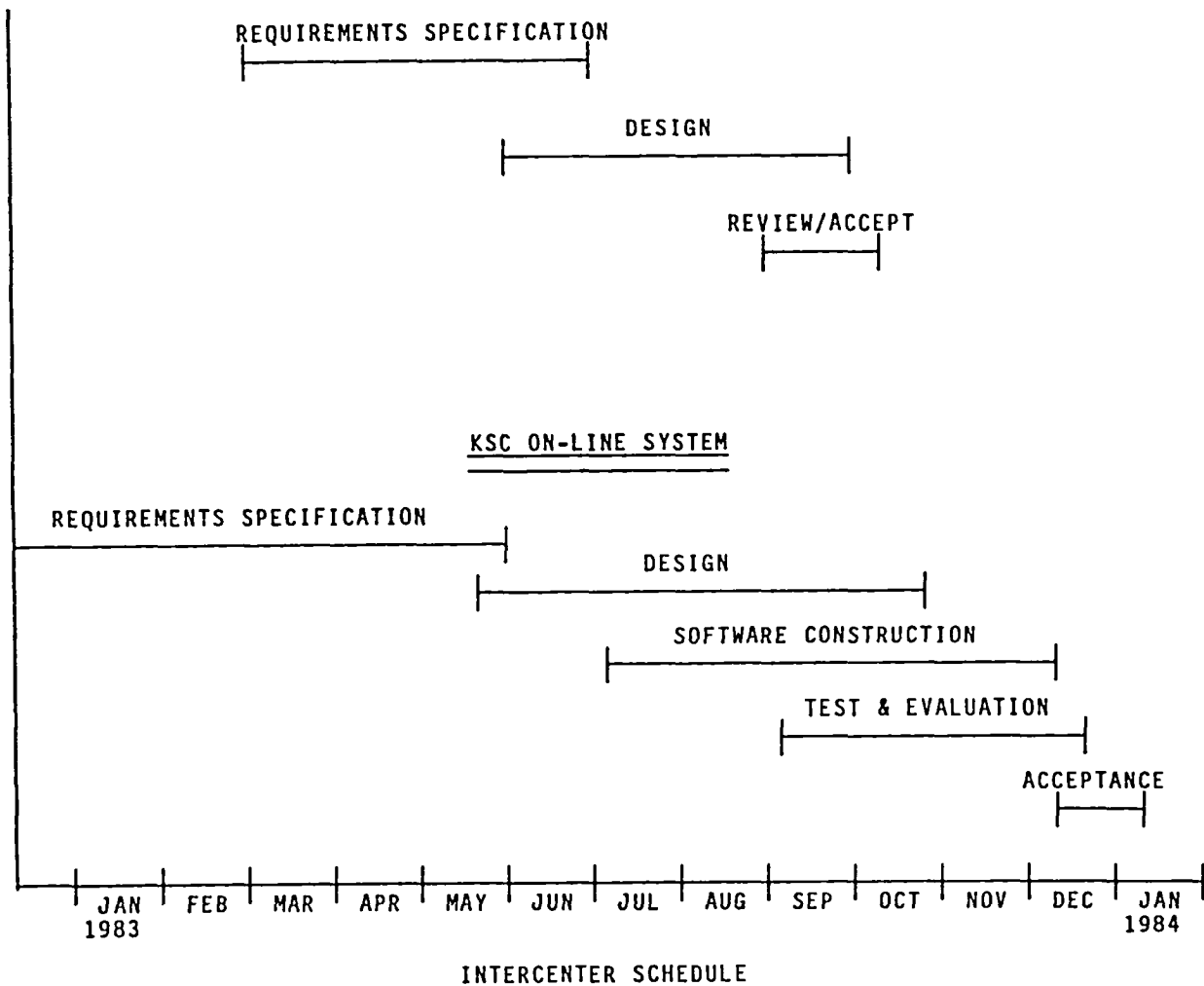

Figure 5-21. Optimum Data System Study.

REFERENCE DOCUMENTS

1. Detailed Functional System Requirements (DFSR) for PRACA System, DOD STS Ground Support Systems, VAFB Operations, December 30, 1982.
2. JSC 08126 PRACA System Requirements for the Space Shuttle Program, Johnson Space Center, December 14, 1982.
3. Kennedy Data Management System, Boeing Services International, Inc., 1981.
4. Kennedy Space Center Problem Reporting and Corrective Action Systems Analysis, Boeing Services International, Inc., September 30, 1982.
5. KMI 5310.11C - KSC Nonconformance/Problem Reporting and Corrective Action System."
6. KSC External Data Interface Study, Problem Reporting, Rockwell International, NAS9-14000 WBS 8.2.11, October 1, 1982.
7. K-STSM-09, Rev. 4 - Space Transportation System Ground Operations Plan, Volume 1 - Operations and Maintenance Management Plan, August 20, 1979.
8. K-STSM-09.2, Rev. A - KSC Space Transportation System, Work Control System Management Plan, May 30, 1978.
9. K-STSM-10.2.91 BK 4.1, Volume 91, February 15, 1978, GOMMS Data Processing Design Requirement Document, KSC Problem Reporting and Corrective Action System.

6. INTEGRATING MICRO-COMPUTERS WITH A CENTRALIZED DBMS: ORACLE, SEED, & INGRES

Jerry Hoerger
Planning Research Corporation
Langley Research Center,

VA

ABSTRACT

Approximately three years ago, BSDS installed a relational-like data base management system (ADABAS) and a data base programming language (NATURAL). The primary goals, such as controlled redundancy of data elements, data independence, increased system development productivity, the ability to share data among organizational units, and easy access to the data by our end users are being realized. Today many of our users are acquiring micro-computers with hopes of solving their individual word processing, office automation, decision support, and simple data processing problems. As processor speeds, memory sizes, and disk storage capacities increase, individual departments will begin to maintain "their own" data base on "their own" micro-computer. This situation will adversely affect several of the primary goals we set for implementing a centralized DBMS. Redundant data elements will appear in several different micros, and data will not be sharable among organizational units.

In order to avoid this potential problem we must integrate these micro-computers with our centralized DBMS. We must provide an easy to use and flexible means for transferring logical data base files between the central data base machine and micro-computers. This paper discusses some of the problems BSDS has encountered in an effort to accomplish this integration and how we hope to solve them.

BSDS SYSTEM CONFIGURATION

BSDS's mainframe consists of an 8 megabyte IBM 4341 model group 2 processor, 16 Memorex 3350 disk drives, 8 STC tape drives, and IBM unit record equipment. The communications network is made up of a Memorex 1270 transmission control unit, an IBM 3705 communications controller, a variety of IBM 3270 compatible terminals, and a mixture of TWX 33/35 compatible teletype terminals. The operating system is MVS/SP with JES2. Software ag's data base management system (ADABAS), system development and query language (NATURAL), and teleprocessing monitor (COM-LETE) are used to provide on-line access to our centralized data base.

The ADABAS data model is essentially a relational model. Files in the data base are defined independently, and relationships between the files are based on fields which exist within the files. For example, a customer/order file relationship could be defined by maintaining the customer number field in both the customer and order files. Within each file a maximum of 200 fields can be defined as descriptors (keys). A logical data base file can be accessed by using several descriptor values in Boolean combination. This architecture enables us to view the data as independent flat files, as hierarchies of files, or as a network of files.

NATURAL is an interactive development language designed for use with ADABAS. It is a procedural language composed of BASIC and COBOL-like syntax. It is particularly useful in the development of structured programs and does reduce program development time substantially. A subset of NATURAL forms the ADABAS report writer and on-line query facility. This is used by our end users to prepare their own reports and on-line queries.

BACKGROUND

Approximately one year ago we began providing formal ADABAS and NATURAL training seminars for all users in our directorate. Managerial, professional, clerical, and secretarial personnel from all divisions have attended these seminars. Since we began these seminars our user base has increased three-fold, and information needs have become more diversified. Managers want graphics, professionals want to be able to create and maintain their own data base files, clerks want more systems automated, and secretaries want word processing and electronic mail. As with any large system the complexities of the centralized DBMS are causing it to become a bottleneck to meeting these disparate needs. The micro-computer on the other hand can solve these problems very easily (if you believe everything you read) provided you can access the centralized DBMS to get the data needed to produce the graph, use with the spreadsheet package, build the data base, or to merge with the form letter.

THE FIRST ENCOUNTER

Our first encounter with a micro-computer came from the training section of personnel. They wanted to maintain class schedules and attendant lists on a data base and merge this data with a word processing package to produce personalized correspondence for the attendants. Other requirements were to download the addresses of attendants from the personnel file on ADABAS, to transmit batched data files between ADABAS and the micro, and to emulate an IBM 3270 terminal for interactively updating attendants personnel records maintained in ADABAS.

A XEROX 820-II micro-computer was leased from a local third party vendor. It looked as though it could solve all of these requirements with very little assistance from the data processing staff. The system consisted of the following components:

H A R D W A R E

- Z80 micro-processor
- 64k random access memory
- letter quality printer
- (1) 8" floppy disk drive
- (1) 10 megabyte hard disk drive
- keyboard and monochrome display
- synchronous communications adapter

S O F T W A R E

CP/M - operating system
DBASE-II - data base manager
WORDSTAR - word processing package
QUICKCODE - data base programming language
BSC3270 - IBM3270 terminal emulator
BSC3780 - IBM3780 data communications terminal
emulator

A 30-day acceptance period was established in which time the hardware and software would be installed and evaluated. The vendor was to be responsible for installing, training, and maintaining all hardware and software components of the system.

After the initial installation, training was to begin on the use of WORDSTAR. This was to begin immediately, but due to unknown sources of hardware problems it was delayed three weeks. During this time I was trying to install the BSC3270 emulator. As with the training, this process was delayed due to hardware problems. By the time the hardware problems were resolved, we were well into our fourth week of the acceptance period so we extended it by four more weeks.

Once the original hardware problems were resolved, training on WORDSTAR began, and it seemed to satisfy the word processing requirements. After several conversations with the vendor, we acquired the BSC3270 software from XEROX, Integrated Systems, Inc., and IE Modem; I finally managed to get the emulator installed and started testing it.

The first problem that surfaced was the inability to communicate at speeds greater than 2400bps. It soon became apparent that the synchronous communications adapter on the XEROX was much more sensitive to signal distortion than a regular terminal controller. After spending a good deal of time adjusting the equalization on the modems, I was able to communicate at 9600bps. The next and final problem was that the BSC3270 emulator would lose synchronization with the host teleprocessing monitor. Neither of the four vendors laying claim to the software could or would solve this problem.

Our extended trial period was about over, so we elected to return the system to the vendor. Neither DBASE-II nor QUICKCODE were installed but after looking at the documentation training, we felt that they would meet their data base management requirements.

THE SECOND ENCOUNTER

The second encounter with a micro-computer came from the Financial Management Division. I'm not exactly sure what the application was but one of the requirements was to download a logical ADABAS file and convert it to a data base file on the micro.

An IBM-PC was purchased from a local computer store and was configured as follows:

H A R D W A R E

Intel 8088 processor
64k random access memory
matrix printer
(2) 5 1/4" floppy disk drives
keyboard and monochrome display
asynchronous communications adapter

S O F T W A R E

DOS 1.1 - operating system
T.I.M. - data base manager
asynchronous communications support -
teletype terminal emulator

The installation of the software and hardware was accomplished by personnel in the Financial Management Division. I assisted them in installing and configuring the asynchronous communication support package. Within a week they were using the data base manager and wanted to start downloading a logical ADABAS file to the IBM-PC.

The asynchronous communications support package allows you to interactively configure the communications adapter and emulator to match the protocol supported by the host teleprocessing monitor. Options such as using XON/XOFF characters to start and stop transmission, selecting a message termination character (XOFF, CR, EOT, etc.), setting the transmission speed, and others are selectable from a menu. Within a few minutes we were able to communicate with ADABAS via NATURAL and with a stroke of a key could record the data coming from the communications adapter on a diskette on the micro.

A utility program provided by the T.I.M. data base manager was then used to convert the transmitted file to a T.I.M. data base file. Unfortunately, the file we transmitted was not in the exact ASCII format required, and several noise records were cluttering the file. Once we determined the ASCII file format required we manually edited the file a record at a time and eventually got it into the ASCII format needed. The edited file was then processed by the conversion utility, and a T.I.M. data base file was built from a logical ADABAS file.

The primary requirement for downloading a logical ADABAS file was accomplished; however, it would have been easier if we had manually entered the data directly from the keyboard.

ESTABLISHING COMMUNICATION STANDARDS

Since the first two requests for transmitting logical ADABAS files to a micro computer, I have heard from three other sections concerning the same problem. The Programs and Resources Division, the Acquisitions Division, and the Office of Director for Management Operations have requested similar capabilities. Given the problems associated with the first two attempts, we decided it was time to establish some standard modes of communication that BSDS would support.

MODES OF COMMUNICATION

Currently, BSDS can support the following modes of communication between the centralized data base and a micro-computer:

- (1) Emulation of an IBM 3270, IBM 3101, and TWX 33/35 teletype terminals
- (2) Interactive selection and transmission of logical ADABAS files via NATURAL
- (3) Batch transmission of data files via JES2's remote job entry subsystem

The remainder of this paper discusses how these modes of communication are used, problems associated with them, and what future developments are required to successfully integrate the micro-computer with our centralized data base management system.

TERMINAL EMULATION

IBM 3270 EMULATION

The IBM 3270 emulator should be used when a high volume of on-line queries, reporting, or transactional processing is required. A synchronous communications adapter is needed on the micro and should support transmission speeds up to 9600bps. The ability to coexist with other IBM 3270 terminals on a multipoint line is also desirable.

The primary problem associated with emulating an IBM 3270 terminal is that of maintaining synchronization with the host teleprocessing monitor. The Binary Synchronous Communications (BSC) protocol is used for communicating with an IBM 3270 terminal. This protocol uses a polling technique to determine if a terminal has data ready to send. Whether it does or not, a response must be sent to the host communications controller within a few seconds or a time out condition will occur. Our teleprocessing monitor (COM-LETE) will ignore a terminal for a minimum of 10 seconds after the 3rd consecutive time out. If the emulator is started during this time it will lose synchronization with COM-LETE. Manual intervention by the host network operator is required at this point, and the emulator will have to be restarted.

IBM 3101 EMULATION

The IBM 3101 terminal emulator should be used for low-volume queries, reporting, and transactional processing. An asynchronous communications adapter is required on the micro and should support transmission speeds up to 1200bps. This terminal can operate in a mode similar to the IBM 3270 as well as a line-oriented teletype terminal. In the block mode it supports full screen formatting, and many of the applications designed for the IBM 3270 can be used.

The primary problem associated with this emulator is that it uses an asynchronous communications protocol. This limits the transmission speed to a maximum of 1200bps. Also, error detection is limited to parity checking on a character by character basis.

TWX 33/35 TELETYPE EMULATION

The teletype emulator should be used for low-volume queries and reporting. An asynchronous communications adapter is required on the micro and should support transmission speeds up to 1200bps.

As with the IBM 3101 emulator, the primary problem with this emulator is that it uses an asynchronous communications protocol. It does not support full screen formatting and cannot be used with applications specifically designed for the IBM 3270.

INTERACTIVE FILE TRANSMISSION

This mode of communication is used for interactively selecting and transmitting a logical ADABAS file to a micro-computer. An asynchronous terminal emulator is used for handling the communications, NATURAL is used for selecting and formatting the file to be transmitted and a utility program on the micro converts the file to a standard ASCII format. The ASCII formatted file seems to be the most commonly used file type on the micro. It is directly accessible by BASIC and most software packages provide utilities for converting them to other formats as needed.

Most asynchronous communication emulators support two modes of operation: one for emulating a teletype terminal and the other for capturing the incoming data on a disk file as well as the display. Both of these modes, in conjunction with NATURAL, are used to select and transmit a logical ADABAS file to a file on the micro. While in terminal mode, a NATURAL program is coded to select the desired logical ADABAS file to be transmitted. The only difference in a NATURAL program used for transmitting a file versus performing a query is the way literal strings are formatted and the write statement used to send a record to the terminal. In a standard query program the data is formatted in a report format. Fields are aligned on the display and column headings are added. When transmitting a file, we do not want the fields aligned nor do we want column headings included in the data. After the program is coded, the emulator is set to the file capture mode and the program is executed.

A sample NATURAL program and the format of the record transmitted is illustrated below:

-NATURAL PROGRAM-

```
RESET #NAME (A26)
RESET #QUOTE (A1)
(1) ASSIGN #QUOTE = H'7F'
FIND PERSONNEL WITH CLASS-CODE = 'C400' THRU 'C499'
(2) COMPRESS #QUOTE NAME #QUOTE INTO #NAME LEAVING NO SPACE
(3) WRITE NOTITLE NOHDR CLASS-CODE EMPLOYEE-NO #NAME
END
```

- (1) A hexadecimal value of '7F' is the EBCDIC representation of a quote mark. Each literal string containing a blank or comma must be enclosed in quotation marks.
- (2) The compress statement is used to form a literal string enclosed in quotation marks. This is required because commas and blanks are included in the value of the name field on the data base.
- (3) The write statement causes a record to be written to the terminal.

-TRANSMITTED RECORD FORMAT-

```
class-codeBemployee-noB"last-name, first-name"CRLF
```

Each field is separated by at least one blank, identified by a capital "B" above, and each record is terminated with a carriage return (CR) and line feed (LF) character.

When the file transmission is complete a utility program on the micro removes noise records and converts the transmitted file to the following standard ASCII format:

-STANDARD ASCII FORMAT-

```
class-code,employee-no,"last-name, first-name"CRLF
```

The only difference between the transmitted file and the ASCII file format is that all the blanks separating the fields have been removed and/or replaced with commas.

The main problems associated with this mode of communication are directly attributable to the asynchronous communications protocol. As with the asynchronous terminal emulators, the maximum reliable transmission speed is 1200bps, and error detection is limited to parity checking on a character by character basis.

BATCHED FILE TRANSMISSION

This mode of communication supports the transmission of files between the central data base and a micro-computer. It can be used for transmitting transactional data used for updating the central data base in batch mode. A synchronous communications adapter is required on the micro and should support transmission speeds up to 9600bps.

The remote job entry subsystem of JES2 is used to facilitate the communications process on the host computer and an IBM 3780/2780 emulator is used on the micro. Files are processed in batch mode on the host and are transmitted as 80 byte punched-card images.

The major problem with this mode of communication is that it is restricted to the batch mode and custom programs must be written to process the files. Another shortcoming is the limitation of only being able to transmit 80 byte punched-card images.

FUTURE DEVELOPMENTS

Many of the mainframe software vendors are beginning to provide software for micro-computers which will allow them to interface directly with their host counterparts. Cullinet, Inc., ISCCO, Inc., and SAS Institute, Inc. have recently announced IBM-PC interfaces to their mainframe data base and graphics software. Software ag has hinted at providing a similar interface for ADABAS.

IBM has announced an IBM 3278 hardware attachment and associated terminal emulation software that will allow the IBM-PC to be directly connected to an IBM 3274 terminal controller. A similar feature is available for the IBM DISPLAY WRITER.

Many small software companies will provide general purpose communications software packages that will allow users to connect their unique data base files via user-written exit programs. This is currently being done for interfacing many of the popular data base management systems with a variety of business application packages

At any rate, given the current state-of-the-art, things can only get better.

- IBM 4341 MODEL GROUP 2 PROCESSOR
- 8 MEGABYTE MEMORY
- 16 MEMOREX 3350 DISK DRIVES
- 8 STC TAPE DRIVES
- IBM UNIT RECORD EQUIPMENT
- MEMOREX 1270 TRANSMISSION CONTROL UNIT AND
IBM 3705 COMMUNICATIONS CONTROLLER
- VARIOUS IBM 3270 COMPATIBLE TERMINALS
- MIXTURE OF TWX 33/35 COMPATIBLE TELETYPE TERMINALS

Figure 6-1. BSDS Hardware Configuration.

- MVS/SP OPERATING SYSTEM WITH JES2
- ADABAS - DATA BASE MANAGEMENT SYSTEM -
SOFTWARE AG
- NATURAL - DEVELOPMENT AND QUERY LANGUAGE -
SOFTWARE AG
- COM-LETE - TELEPROCESSING MONITOR -
SOFTWARE AG

Figure 6-2. BSDS Software Configuration.

- INVERTED LIST STRUCTURE
- SUPPORTS RELATIONAL, HIERARCHICAL, OR NETWORK MODELS
- 255 FILES PER DATA BASE
- 200 DESCRIPTORS (KEYS) PER FILE
- RELATIONSHIPS BETWEEN FILES ARE BASED ON FIELDS WITHIN THE FILES

Figure 6-3. ADABAS Architecture.

- INTERACTIVE PROGRAM DEVELOPMENT LANGUAGE
- PROCEDURAL WITH MIXTURE OF BASIC AND COBOL SYNTAX
- SUBSET PROVIDES END USER REPORT WRITING AND ON-LINE QUERY CAPABILITIES

Figure 6-4. Natural Language.

- CONTROLLED REDUNDANCY OF DATA ELEMENTS
- DATA INDEPENDENCE
- INCREASED SYSTEM DEVELOPMENT PRODUCTIVITY
- ABILITY TO SHARE DATA AMONG ORGANIZATIONAL UNITS
- EASY ACCESS BY OUR "END USERS"

Figure 6-5. Centralized DBMS Objectives.

- FORMAL ADABAS/NATURAL TRAINING SEMINARS
- MANAGEMENT, PROFESSIONALS, CLERICAL, AND SECRETARIAL PERSONNEL (250 USERS)
- TRAINING HAS PRODUCED NEW REQUIREMENTS
 - GRAPHICS
 - WORD PROCESSING
 - DYNAMIC DEFINITION AND CREATION OF DATA BASE FILES

Figure 6-6. Expanded User Community.

- CONTROL SOMETIMES PROHIBITS FLEXIBILITY
- COMPLEXITY DEMANDS DATA PROCESSING SPECIALISTS
- DEVELOPMENT TIME IS STILL A BOTTLENECK
- SOFTWARE MUST INTERFACE TO THE DBMS

Figure 6-7. Problems Associated with a Centralized DBMS.

- NO CONTROL REQUIRED
- MANY WORD PROCESSING, DECISION SUPPORT, GRAPHICS,
AND DATA BASE MANAGEMENT PACKAGES
- SIMPLICITY DOES NOT REQUIRE DATA PROCESSING SPECIALIST
- APPLICATIONS CAN BE DONE BY THE END USER

Figure 6-8. The Micro Computer Solution.

- TRAINING SECTION OF PERSONNEL
- MAINTAIN CLASS SCHEDULES AND ATTENDANT
LISTS ON A DATA BASE
- MERGE DATA BASE FILES WITH A WORD PROCESSING
PACKAGE TO PRODUCE PERSONALIZED CORRESPONDENCE
FOR ATTENDANTS
- DOWNLOAD ATTENDANT ADDRESSES FROM THE CENTRAL
PERSONNEL FILE MAINTAINED ON ADABAS TO THE DATA
BASE ON THE MICRO
- EMULATE AN IBM 3270 TERMINAL FOR INTERACTIVELY
UPDATING ATTENDANTS PERSONNEL RECORDS MAINTAINED
ON ADABAS

Figure 6-9. The First Encounter.

- HARDWARE
 - XEROX 820-II MICRO COMPUTER
 - 64K RANDOM ACCESS MEMORY
 - LETTER QUALITY PRINTER
 - (1) 8" FLOPPY DISK DRIVE
 - (1) 10 MEGABYTE HARD DISK DRIVE
 - KEYBOARD AND MONOCHROME DISPLAY
 - SYNCHRONOUS COMMUNICATIONS ADAPTER
- SOFTWARE
 - CP/M - OPERATING SYSTEM
 - DBASE-II - DATA BASE MANAGER
 - WORDSTAR - WORD PROCESSING PACKAGE
 - QUICKCODE - DATA BASE PROGRAMMING LANGUAGE
 - BSC3270 - IBM 3270 TERMINAL EMULATOR
 - BSC3780 - IBM 3780 DATA COMMUNICATIONS TERMINAL
EMULATOR

Figure 6-10. Micro System Configuration.

- INITIAL UNKNOWN HARDWARE PROBLEMS
- LACK OF SKILLED TRAINER
- INABILITY TO COMMUNICATE AT SPEEDS GREATER THAN 2400 BPS
- LOSS OF SYNCHRONIZATION WITH HOST TELEPROCESSING MONITOR
- PROBLEM RESOLUTION WAS NEVER ACCOMPLISHED

Figure 6-11. Problems Encountered.

- FINANCIAL MANAGEMENT DIVISION
- CREATE AND MAINTAIN A DATA BASE FILE CONTAINING FINANCIAL DATA NOT MAINTAINED ON ADABAS
- DOWNLOAD A PORTION OF THE FINANCIAL FILE MAINTAINED ON ADABAS TO THE DATA BASE ON THE MICRO
- MERGE THE TWO FILES FOR REPORTING

Figure 6-12. The Second Encounter.

- HARDWARE

- IBM-PC MICRO COMPUTER
- 64K RANDOM ACCESS MEMORY
- MATRIX PRINTER
- (2) 5 $\frac{1}{4}$ " FLOPPY DISK DRIVES
- KEYBOARD AND MONOCHROME DISPLAY
- ASYNCHRONOUS COMMUNICATIONS ADAPTER

- SOFTWARE

- DOS 1.1 - OPERATING SYSTEM
- T. I. M. - DATA BASE MANAGER
- ASYNCHRONOUS COMMUNICATIONS SUPPORT -
TELETYPE TERMINAL EMULATOR

Figure 6-13. Micro System Configuration.

- CONVERSION OF THE DOWNLOADED ADABAS FILE
COULD NOT BE ACCOMPLISHED BECAUSE IT WAS
NOT IN THE APPROPRIATE FORMAT FOR THE
T. I. M. CONVERSION UTILITY
- MANUAL EDITING OF THE DOWNLOADED FILE
WAS REQUIRED

Figure 6-14. Problems Encountered.

- EMULATION OF IBM 3270, IBM 3101, AND TWX 33/35 TELETYPE TERMINALS
- INTERACTIVE SELECTION AND TRANSMISSION OF LOGICAL ADABAS FILES VIA NATURAL
- BATCH TRANSMISSION OF TEXT AND/OR DATA FILES VIA JES2'S REMOTE JOB ENTRY SUBSYSTEM

Figure 6-15. Standard Modes of Communication.

- USED FOR HIGH VOLUME QUERIES, REPORTING, AND BSDS DEVELOPED FILE MAINTENANCE SYSTEMS
- BINARY SYNCHRONOUS COMMUNICATIONS PROTOCOL
- TRANSMISSION SPEEDS OF 2400 TO 9600 BPS
- FULL SCREEN FORMATTING CAPABILITY

Figure 6-16. IBM 3270 Emulation.

- USED FOR LOW VOLUME INTERACTIVE QUERIES, REPORTING, AND BSDS DEVELOPED FILE MAINTENANCE SYSTEMS
- ASYNCHRONOUS COMMUNICATIONS PROTOCOL
- TRANSMISSION SPEEDS OF 300 TO 1200 BPS
- FULL SCREEN FORMATTING CAPABILITY

Figure 6-17. IBM 3101 Emulation.

- USED FOR LOW VOLUME QUERIES AND REPORTING
- ASYNCHRONOUS COMMUNICATIONS PROTOCOL
- TRANSMISSION SPEEDS OF 300 TO 1200 BPS

Figure 6-18. TWX 33/35 Emulation.

- USED FOR INTERACTIVELY SELECTING AND TRANSMITTING LOGICAL ADABAS FILES TO THE MICRO
- ASYNCHRONOUS TERMINAL EMULATOR USED FOR HANDLING COMMUNICATIONS
- NATURAL IS USED FOR SELECTING AND FORMATTING THE LOGICAL ADABAS FILE TO BE TRANSMITTED
- UTILITY PROGRAM ON THE MICRO IS USED TO CONVERT THE TRANSMITTED FILE TO A STANDARD ASCII FORMAT

Figure 6-19. Interactive File Transmission.

RESET #NAME (A26)

RESET #QUOTE (A1)

- (1) ASSIGN #QUOTE = H'7F'
FIND PERSONNEL WITH CLASS-CODE = 'C400' THRU 'C499'
 - (2) COMPRESS #QUOTE NAME #QUOTE INTO #NAME
LEAVING NO SPACE
 - (3) WRITE NOTITLE NOHDR CLASS-CODE EMPLOYEE-NO #NAME
END
-
- (1) EACH LITERAL STRING CONTAINING A COMMA MUST BE ENCLOSED WITHIN QUOTATION MARKS. (H'7F' = ")
 - (2) THE COMPRESS STATEMENT IS USED TO ENCLOSE THE DATA BASE FIELD NAME IN QUOTATION MARKS.
 - (3) THE WRITE STATEMENT CAUSES THE RECORD TO BE WRITTEN TO THE COMMUNICATIONS LINE.

Figure 6-20. Natural Program.

CLASS-CODE B EMPLOYEE-NO B "LAST-NAME, FIRST-NAME" CRLF

- EACH FIELD IS SEPARATED BY A BLANK
- EACH RECORD IS TERMINATED BY A CARRIAGE RETURN (CR) AND LINE FEED (LF) CHARACTER

Figure 6-21. Transmitted Record Format.

CLASS-CODE, EMPLOYEE-NO, "LAST-NAME, FIRST-NAME" CRLF

- UTILITY PROGRAM ON THE MICRO CONVERTS THE TRANSMITTED FILE TO THE STANDARD ASCII FORMAT
- ASCII FORMAT IS ACCESSIBLE BY BASIC
- MANY MICRO SOFTWARE PACKAGES PROVIDE UTILITIES FOR CONVERTING ASCII FILES TO FORMATS REQUIRED

Figure 6-22. Standard ASCII Format.

- USED FOR TRANSMITTING DATA/TEXT FILES BETWEEN THE CENTRAL DBMS AND A MICRO COMPUTER
- IBM 2780 TERMINAL EMULATOR AND JES2'S REMOTE JOB ENTRY SYSTEM HANDLE COMMUNICATIONS
- THE FILE TO BE TRANSMITTED IS CREATED AND ROUTED TO THE MICRO IN BATCH
- TEXT FILES ARE TRANSMITTED AS 80 BYTE PUNCHED-CARD IMAGES
- DATA FILES ARE TRANSMITTED AS 132 CHARACTER PRINT IMAGES

Figure 6-23. Batched File Transmission.

- MAINFRAME SOFTWARE VENDORS WILL PROVIDE SOFTWARE TO DIRECTLY LINK THE MICRO WITH THEIR HOST COUNTERPARTS. (CULLINET, INC., ISSCO, INC., SAS INSTITUTE, INC.)
- IBM-PC CAN BE ATTACHED DIRECTLY TO AN IBM 3274 CONTROLLER.
- SMALL SOFTWARE COMPANIES WILL PROVIDE GENERAL PURPOSE ALLOWING ACCESS TO A VARIETY OF DATA BASES.
- APPLICATION DEVELOPMENT WILL EXTEND TO THE MICRO.
- END USER COMMUNITY WILL BE THE DRIVING FORCE.

Figure 6-24. Future Developments.

7. QUANTITATIVE EVALUATION OF THREE DBMS: ORACLE, SEED, & INGRES

Regina Sylto
Goddard Space Flight Center

- 0 NASA SCIENTIFIC DATA BASE MANAGEMENT APPLICATIONS
- 0 PERFORMANCE TESTING OBJECTIVES
- 0 SAMPLE OF PERFORMANCE TESTING RESULTS
- 0 CONCLUSION

Figure 7-1. Presentation Outline.

CHARACTERISTICS:

- 0 LARGE AMOUNTS OF SCIENTIFIC INFORMATION MUST BE MANAGED.
- 0 CURRENTLY, MOSTLY META-INFORMATIONAL DATA ABOUT SCIENTIFIC DATA SETS IS MANAGED.
- 0 CHANGES ARE NOT MADE FREQUENTLY TO THE META-INFORMATION.

DBMS REQUIREMENTS:

- 0 EMPHASIS ON LOAD AND ACCESS OF DATA
- 0 DE-EMPHASIS ON UPDATING AND DELETING OF DATA

EXAMPLES:

- 0 PILOT CLIMATE DATA BASE MANAGEMENT SYSTEM (PCDBMS)
- 0 CRUSTAL DYNAMICS/DIS
- 0 LANDSAT 4/SIS
- 0 PACKET MANAGEMENT SYSTEM (PMS)

Figure 7-2. NASA Scientific Data Base Management Applications.

FIRST LEVEL (FY81):

- 0 TO ASSESS CAPABILITIES OF DATA BASE MANAGEMENT SYSTEMS (DBMS) TO MANAGE LARGE AMOUNTS OF DATA (AT LEAST 1 MILLION INPUT RECORDS PER APPLICATION, 130 MEGABYTES)
- 0 TO DETERMINE DATA BASE LOAD RATES
- 0 TO MEASURE THE EFFICIENCY OF VARIOUS DATA ACCESS TECHNIQUES USED IN THE DBMS PACKAGES
- 0 TO EVALUATE QUALITATIVE CHARACTERISTICS

SECOND LEVEL (FY82 - FY83):

- 0 TO DETERMINE THE EFFECTS OF VARYING THE FOLLOWING FACTORS:
 - INTERNAL DBMS PARAMETERS:
 - FIELD SIZE, NO. OF FIELDS, FIELD TYPES
 - NO. OF KEYS, KEY LENGTH, DUPLICATION OF KEY VALUES
 - EXTERNAL DBMS PARAMETERS:
 - NUMBER OF USERS (1-15) (DBMS AND VAX)
 - DBMS AND VAX/VMS OPERATING SYSTEM PARAMETERS
- 0 TO PROVIDE A BASIS FOR PREDICTING THE EFFECT OF VARIOUS DB DESIGNS
- 0 TO PROVIDE A BASIS FOR DBMS SELECTION

Figure 7-3. Performance Testing Objectives.

ORACLE:

- 0 MARKETED BY ORACLE CORPORATION (1980)
- 0 RELATIONAL MODEL
- 0 275 INSTALLATIONS

SEED:

- 0 MARKETED BY SEED SOFTWARE INCORPORATED (1979)
- 0 NETWORK MODEL
- 0 107 INSTALLATIONS

RIM:

- 0 NASA/LARC IN-HOUSE PRODUCT (1980), MARKETED BY BOEING (1982)
- 0 RELATIONAL MODEL
- 0 ? INSTALLATIONS

INGRES:

- 0 MARKETED BY RELATIONAL TECHNOLOGY INC. (1981)
- 0 RELATIONAL MODEL
- 0 210 INSTALLATIONS

Figure 7-4. DBMS Packages.

	ORACLE	SEED	RIM
SENSITIVITY OF LOAD RATES TO DB SIZE	FAIRLY CONSTANT FOR ALL SIZE DATA BASES	LARGE DEGRADATION AS DB SIZE INCREASES	STABILIZES AS DB SIZE INCREASES
USER OPTIONS TO IMPROVE LOAD RATES	LITTLE FLEXIBILITY	MANY OPTIONS (HASH, DIRECT)	LITTLE FLEXIBILITY
QUERY RATES WITH INDEXED SEARCH	* * * ALL SYSTEMS ACCEPTABLE AT ALL SIZES (5K - 1M RECORDS) * * *		
QUERY RATES WITH EXHAUSTIVE SEARCH (NON-INDEXED & SUMMARIES)	* * * NO SYSTEM ACCEPTABLE AT 1M RECORDS * * *		

Figure 7-5. DBMS Technology-First Level Performance Testing Results (FY 81).

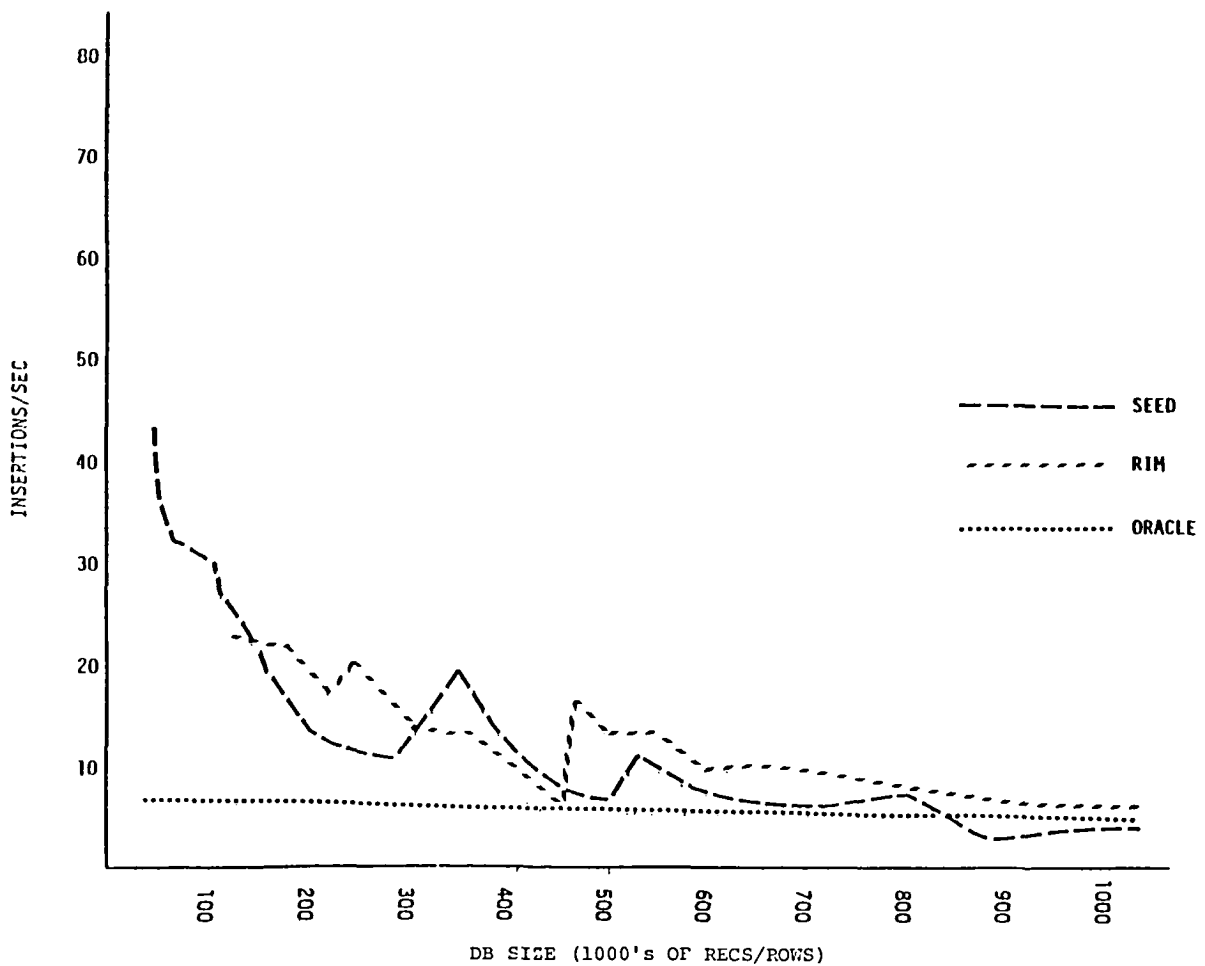

Figure 7-6. LIMS Test Data Base-Load Summary.

TEST PERFORMED	SEED VC0.03				
	ORACLE V2	ORACLE V3	INGRES	INDEX	RECORD
KEY OVERHEAD					
LOAD	22.5%	30.2%	9% - 16%	11.2%	40.8%
UPDATE	52.9%	90% DEGRAD.	32%	63%	225%
DELETE	NC	13%	20%	22%	30%
DUPLICATION OF KEY VALUE					
LOAD	NC	NC	2X:4% 5X:2% 10X:.8%	NC	2X:20% 5X:3% 10X:19% IMPROVEMENT
UPDATE	NC	NC	NC	8%-15%	NC
DELETE	NC	NC	NC	4%	NC

$$\% \text{ DEGRAD} = \frac{\text{CONTROL TIME} - \text{TEST TIME}}{\text{CONTROL TIME}}$$
 NC = NO CORRELATION

Figure 7-7. DBMS Technology-Second Level Performance Testing Results (FY82-FY83) (% Degradation Except Where Noted).

TEST PERFORMED	ORACLE V2	SEED	
	# OF KEYED FIELDS (4→3→1)		
		(VERSION B.11)	
LOAD	3 KEYS 20% IMPROVEMENT 1 KEY 58% IMPROVEMENT	3 KEYS 28% IMPROVEMENT	1 KEY 100% IMPROVEMENT
KEY LENGTH (BYTES: 4, 8, 12)			
		(VERSION CO.03)	
LOAD	NC	INDEX 6% - 7%	RECORD 3%
QUERY	5.3% WITH 12 BYTES	NC	NC
COMPLEXITY OF DB DESIGN			
		(VERSION CO.02)	
LOAD	6.6%	18.9%	
QUERY	5% IMPROVEMENT	28.6%	

$$\% \text{ DEGRADATION} = \frac{\text{CONTROL TIME} - \text{TEST TIME}}{\text{CONTROL TIME}}$$
 NC = NO CORRELATION

Figure 7-8. DBMS Technology-Second Level Performance Testing Results (FY82-FY83) (% Degradation Except Where Noted)

TEST PERFORMED	ORACLE V2	ORACLE V3	INGRES	SEED VCO-02
FIELD SIZE (BYTES: 10,20,31)				
LOAD	NC			12-3%
QUERY	33%			NC
# OF FIELDS (1X,2X,3X,7X)				
LOAD	4.7% - 15.4%	5.6% - 15.1%	2.1% - 5%	7X:2% IN CPU
QUERY	5% - 15%	2.2% - 11%	7% - 31%	NC
FIELD TYPE (INT*2 vs CHAR*2)				
DEGRADATION WITH INT*2				
LOAD	NC	1.6% - 5.7%		.8% - 6.7%
QUERY	NC	4.6% - 8.6%		NC

$$\% \text{ DEGRAD} = \frac{\text{CONTROL TIME} - \text{TEST TIME}}{\text{CONTROL TIME}}$$
 NC = NO CORRELATION

Figure 7-9. DBMS Technology-Second Level Performance Testing Results (FY82-FY83) (% Degradation).

	ORACLE V2	ORACLE V3	INGRES	SEED VB.11
NON-DBMS CONTENTION				
LOAD AND FORTRAN PROG.	5% TO 11%	40% TO 44%	REPEAT APP. 41% COPY 19%	47% TO 51%
QUERY* & COMPILE	1.5	1.5	1.3	1.6
5 QUERIES* & COMPILE	4.1	4.2	4.1	4.2
DBMS QUERY CONTENTION*	SIMULT.	SIMULT. 3 SEC. WAIT	SIMULT. 3 SEC. WAIT	SIMULT. 3 SEC. WAIT
# OF USERS				
5	3.7	3.9 3.6	4.3 4	4.4 3.6
10	7.2	7.6 6.8	8.6 8	20.4 6.8
15	10.1	10.9 10	12.9 11.7	31.2 20
VARIATION IN LOAD	CREATED: 17-8% RE-INIT: 15%	***	***	3% - 4%

NC = NO CORRELATION % DEGRAD = $\frac{\text{CONTROL TIME} - \text{TEST TIME}}{\text{CONTROL TIME}}$

*DEGRAD. FACTOR = $\frac{\text{TEST TIME}}{\text{CONTROL TIME}}$

Figure 7-10. DBMS Technology-Second Level Performance Testing Results (FY82-FY83) (% Degradation).

ORACLE V3				INGRES	SEED
<u>BUFFERING:</u>				<u>VARYING PRIMARY & SECONDARY KEYS:</u>	<u>HASHING ALGORITHM:</u>
BUFFER #	LOAD	QUERY	PAGE FAULTS IN LOAD	FOR 13K DB, SECONDARY KEYS INSIGNIFICANT BECAUSE QUERY OPTIMIZATION BASED ON TABLE STATISTICS	NO IMPACT BETWEEN USE OF CHARACTER ALGORITHM VS. INTEGER ALGORITHM.
-----	----	-----	-----		
50	-	-	-		
100	25%*	NC	DEC.		
200	34%*	NC	INC.		
IDEAL BUFFER SIZE: 100					<u>JOURNALING:</u>
*%IMPROVEMENT					ROLL BACKWARDS : 60% DEGRAD.
<u>SPACE DEF.:</u> 4.4% IMPROVEMENT WHEN INITIAL SPACE IS LARGE.				<u>JOURNALING:</u> 16.5% DEGRADATION IN LOAD	TRANSC. AFTER RECORD OR BURST: 0% TO 1% DEGRAD.
<u>CLUSTERING:</u> IMPROPER USAGE DECREASES PERFORMANCE BY FACTOR OF 3					<u>BUFFERING:</u> SIZE OF BUFFER IS SIZE OF LARGEST PAGE, 40% DIFFERENCE

Figure 7-11. Variation of DBMS System Parameters.

HEADER

PRIMARY_KEY*	MTD_SID*	TIME*	UTC	SDF	MESSAGE	HEADER
CHAR (9), NOT NULL, UNIQUE	NUMBER, NOT NULL	NUMBER, NOT NULL	NUMBER	NUMBER, NOT NULL	CHAR (31)	CHAR (64), NOT NULL

*KEYED FIELD

1 ROW = 114 BYTES

Figure 7-12. PMS Oracle Data Base - Standard Design.

HEADER

MID_SID*	SSC	SDF	TIME*	UTC	MESSAGE	HEADER
INT*2	INT*2	INT*2	INT*4	INT*2	CHAR (31)	CHAR (64)

*SECONDARY KEY

THE COMBINATION OF MID_SID, SSC, SDF, AND TIME FORMED THE PRIMARY KEY.

1 ROW = 107 BYTES

Figure 7-13. PMS Ingres Data Base - Standard Design.

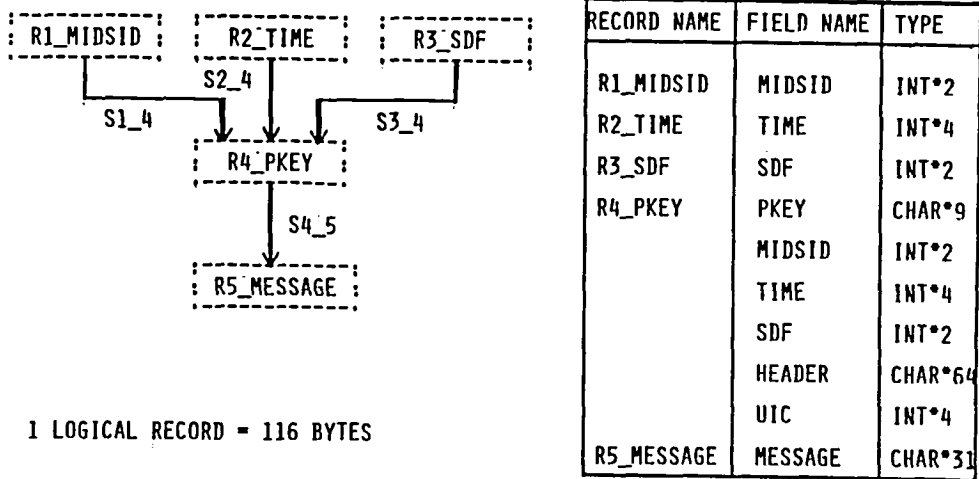

Figure 7-14. PMS Seed Data Base - Standard Design.

DBMS PACKAGE	MAJOR ADVANTAGES	MAJOR DRAWBACKS
ORACLE	EASY TO USE EASY TO CHANGE DB DESIGN GOOD FOR : - DYNAMIC SCIENTIFIC RESEARCH ENVIRONMENT - CASUAL USERS	HIGH RESOURCE UTILIZATION PRODUCT NOT FULLY DEVELOPED CONCLUDE: - OPERATIONAL ENVIRONMENT NEEDS IMPROVEMENT
INGRES	EASY TO USE EASY TO CHANGE DB DESIGN GOOD QUERY OPTIMIZATION SECURITY AND INTEGRITY GOOD FOR: - DYNAMIC, UNPREDICTABLE, SMALL TO MEDUM SIZE DB ENVIRONMENT - CASUAL USERS	MAX OF 1 DISK PER DB APPLICATION INEFFICIENT LOAD RATES WITH KEYS QUERY LANG. LACKS CAPABILITIES NULL VALUES NOT EXPRESSED NOT GOOD FOR: - LARGE DATA BASE APPLICATIONS
SEED	LOWER RESOURCE UTILIZATION MORE MATURE PRODUCT GOOD FOR: - OPERATIONAL ENVIRONMENT (RELIABLE) - STATIC DATA BASES - EFFICIENT DISK SPACE USE	CREATING AND UPDATING IS COMPLEX CHANGING DB DESIGN IS A BURDEN RISKY FOR: - DYNAMIC, UNPREDICTABLE DATA BASES - CASUAL USERS TO CREATE AND MODIFY DATA BASES

RIM WAS NOT CONSIDERED SERIOUSLY BECAUSE IT IS NOT AS COMPLETE OR THOROUGHLY IMPLEMENTED (E.G., SINGLE USER, NO REPORT WRITER, LIMITED USER VIEW CAPABILITY)

Figure 7-15. Conclusions of DBMS Packages.

- 0 PERFORMANCE TESTING SHOWS THAT VENDOR PACKAGES CAN MANAGE 130 MEGABYTES OF DATA AT ACCEPTABLE LOAD AND QUERY RATES.
- 0 PERFORMANCE TESTS VARYING DB DESIGNS AND VARIOUS DBMS PARAMETERS ARE VALUABLE TO APPLICATONS FOR CHOOSING DBMS PACKAGES AND CRITICAL TO DESIGNING EFFECTIVE DATA BASES.
- 0 AN APPLICATION'S PRODUCTIVITY INCREASES WITH THE USE OF A DBMS BECAUSE OF ENHANCED CAPABILITIES:
 - SCREEN FORMATTER
 - REPORT WRITER
 - DATA DICTIONARY

Figure 7-16. Conclusion.

- 0 FURTHER PERFORMANCE TESTS NEED TO BE MADE WITH NEW RELEASES (E.G., ORACLE V3)
- 0 DATA BASE MACHINES SHOULD BE INVESTIGATED TO IMPROVE PERFORMANCE, ESPECIALLY TO SUPPORT MANAGEMENT OF VERY LARGE ON-LINE DATA SETS.

Figure 7-17. Future.

DOCUMENTATION:

- 0 TM 82176, ERB-6 DATA INVENTORY, JUNE 1981, R. SYLTO
- 0 TM 83942, AUGUST 1981, E. MARTIN, R. SYLTO, ET AL
- 0 RESULTS OF DATA BASE MANAGEMENT SYSTEM PARAMETERIZED PERFORMANCE TESTING RELATED TO GSFC SCIENTIFIC APPLICATIONS,
IN FINAL DRAFT
- 0 SUPPLEMENTAL PERFORMANCE TESTING, IN FIRST DRAFT

MAJOR PRESENTATIONS:

- 0 DBMS PANEL; THIRD WORKSHOP - DECEMBER 1980
- 0 ISG OF OAST DSTP - OCTOBER 1982
- 0 SEED USERS' GROUP MEETING - MAY 1982
- 0 REGIONAL ORACLE USERS' GROUP MEETING - JUNE 1983

CONSULTING WITHIN NASA:

- 0 GSFC DYNAMICS EXPLORER GROUND SYSTEM
- 0 GSFC SPACE TELESCOPE GROUND SYSTEM
- 0 JPL OCEANS PILOT SYSTEM
- 0 MSFC DBMS
- 0 OAST ADMINISTRATIVE DATA BASES

Figure 7-18. Publications of Results and Activities.

8. AUTOMATED ADMINISTRATIVE DATA BASES

Michele D. Marrie (Presenter) Susan A. Reising (Presenter)
Joyce R. Jarrett John E. Hodge
Applications Resource Management Office
Code 901, Goddard Space Flight Center,
Greenbelt, MD

BACKGROUND

Over the past two years, members of the Applications Directorate Resources Management Office have developed a number of administrative automated systems in order to respond to the ever-increasing Internal Management, Center, and Headquarters requirements for information. The various requirements were calling for the same time of information from many levels at the Center on a fairly routine basis.

It became apparent that a significant improvement in productivity and the ability to respond more effectively could be achieved using automated techniques.

APPROACH

A detailed review of the previous method of providing this information was conducted and the problems associated with each were highlighted. An analysis was made, and the areas that warranted automation were:

- o Civil Service Manpower
- o Research Technology Objectives and Plan (RTOPs)
- o Full Time Equivalency (FTE)
- o Training
- o Work Requests
- o Reimbursable Agreements
- o Physical Space
- o Travel
- o Furniture Budgeting
- o Copier Inventory

EQUIPMENT

HARDWARE

Existing hardware, the IBM 4341, was used in all cases. Existing CRTs, printers and modems of various types were used.

SOFTWARE

Existing software, the RAMIS Data Base Management System, was used. The IBM Time Sharing Option (TSO) utility was also used to allow more efficient use of RAMIS. Flexibility for expansion to accommodate other GSFC and Headquarters users was considered throughout the development phase of our resources systems. Training was provided to internal personnel who would use the system.

MODULES SELECTED FOR PRESENTATION AT CONFERENCE

MANPOWER

An annual exercise which involves submission of plans to Center and Headquarters management prompted the development of this automated activity. The previous manual method was found to be very time consuming, required a large volume of paperwork, and involved a large quantity of manual calculations which impacted the accuracy level.

By using the RAMIS automated system our steps in the manpower exercise were reduced from 16 to 10. The benefits we have derived thus far are listed below:

- o Elimination of loadsheets and manually prepared summaries.
- o Rejects available for review and correction faster and without loadsheets--many were handled via telephone.
- o By-name data is available for hiring/staffing plans and analysis throughout the year.
- o Consolidation of paperwork as information is transferred via printouts.
- o Summaries available from these data bases provide various levels of detail which are used to assist in variance analysis throughout the year.
- o SOW data can be used as a guide during next exercise.
- o There are fewer manual calculations: required accuracy rate improves because significantly fewer rejects received.

RTOPs

A labor-intensive annual exercise which involves submission of proposed dollar and manpower amounts for each task and RTOP to Center and Headquarters management prompted automation of this activity. The previous manual method was time consuming, required a large volume of paperwork, and was considered to have a debatable level of accuracy due to the large amount of manual calculations necessary.

Benefits we have realized from using the automated RAMIS system are highlighted below.

- o Reduction of paperwork, i.e., logs, handwritten summaries
- o Active data base to refer to throughout the year
- o Increased level of accuracy due to fewer manual calculations
- o Capability for the Financial Management Division (FMD) to retrieve data directly from our data base eliminating need for paper submission by due date

* PILOT *

- o Automatic data transfer of Headquarters guidelines to GSFC's data base
- o Automatic data transfer from GSFC's data base to Headquarters' data base.

FULL TIME EQUIVALENCY (FTE)

There is a quarterly Center exercise and a monthly Directorate exercise to provide full time equivalency (FTE) information.

We found the manual method previously used to be very time consuming due to manual calculations and preparation of reports, and we had a debatable level of accuracy because numerous calculations had to be performed.

The present method was developed using a RAMIS database allowing us to input the data and print out our report for submission to the Personnel Division.

Benefits we have received from the automated system are as follows:

- o Time savings and increased accuracy due to elimination of manual calculations, and use of Center data base housing actual data
- o Ability to obtain recovery rate automatically
- o Elimination of typed report

PHYSICAL SPACE

There are three requirements for physical space information:

- o Annual Zero-base Space Exercise
- o Annual Building Space Utilization Exercise
- o Space Management needs

The previous method used to compile the data was to conduct numerous physical walk-throughs and submit manual inputs.

The problems we found were that the data was insufficient for internal space needs and the walk-throughs were extremely time-consuming.

Therefore a new method was developed using a RAMIS data base.

The benefits experienced were that:

- o Level of effort was reduced for Center exercises.
- o All formats for the Center exercises were prepared via computer.
- o The system was able to facilitate other exercises such as:
 - Internal division/directorate space management needs
 - Personnel on-board (grants, coops, visiting scientists, etc.)
 - On-site contractor exercises, etc.

SUMMARY

As you have noted from the four modules selected for presentation, benefits of automation include reduced duplication, increased communication, time savings, etc., and the potential for a much greater savings by sharing and integrating with those who have the same requirements.

Since other field centers often respond to Headquarters requirements as Goddard does, it is hoped that our systems can be shared to extend these benefits to other parts of the Agency. Additionally, we look forward to learning and utilizing systems developed by other agencies in order to continually improve productivity and efficiency through automation.

**9. METHOD FOR ACCESSING
DISTRIBUTED HETEROGENEOUS
DATABASES**

**Barry E. Jacobs
Department of Computer Science
University of Maryland**

PROBLEM: Given a set of heterogeneous distributed databases, how can a user uniformly access all of the data?

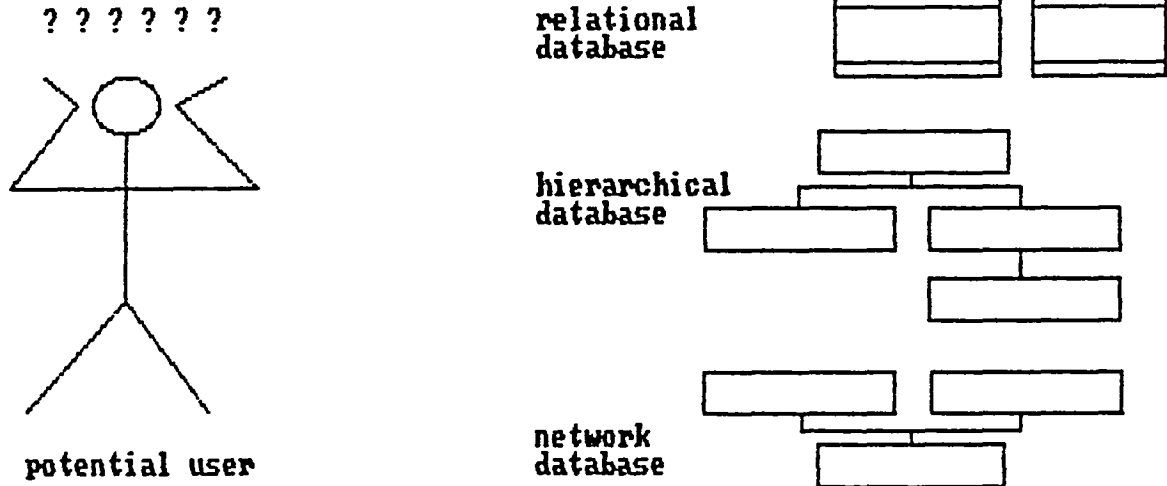

Figure 9-1

- o Illustrative Scenario
- o The Global Data Manager
- o The Components of the Global Data Manager
- o Research in Progress
- o Summary

Figure 9-2. Outline of Talk.

travel					funding				
id#	name	date	state	loc	id#	name	date	fund	purp.
1111	jones	3.12	calif	jpl	1111	jones	3.12	sk46	---
2222	smith	4.23	texas	jsc	2222	smith	4.23	fj55	---
3333	green	3.28	calif	arc	3333	green	3.28	rk44	---

- o This is an ORACLE relational database which is physically located at Goddard Space Flight Center.
- o The data is stored internally in ASCII.

Figure 9-3. A Relational Database.

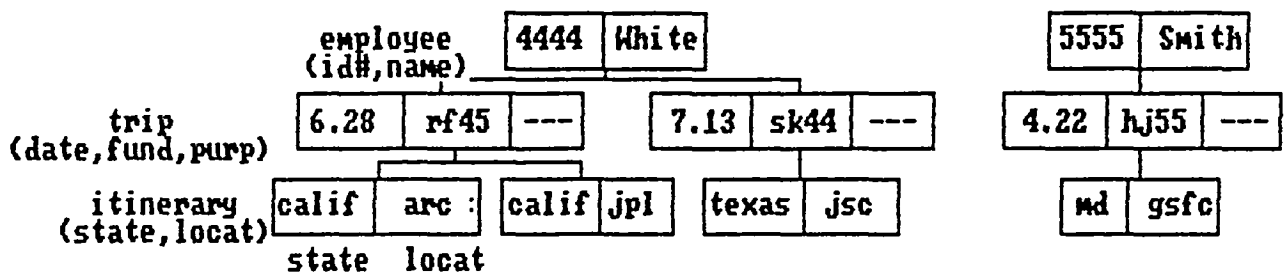

- o This is an IMS hierarchical database which is physically located at Jet Propulsion Lab.
- o This data is stored internally in EBCDIC.

Figure 9-4. A Hierarchical Database.

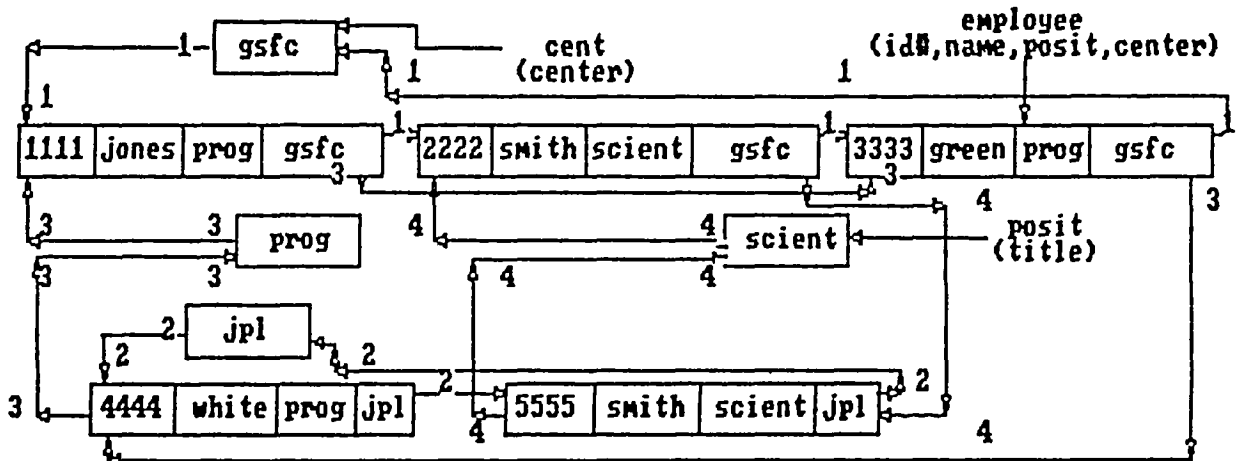

- o This is a CODASYL network database which is physically located at NASA headquarters.
- o The data is stored internally in ASCII.

Figure 9-5. Network Database.

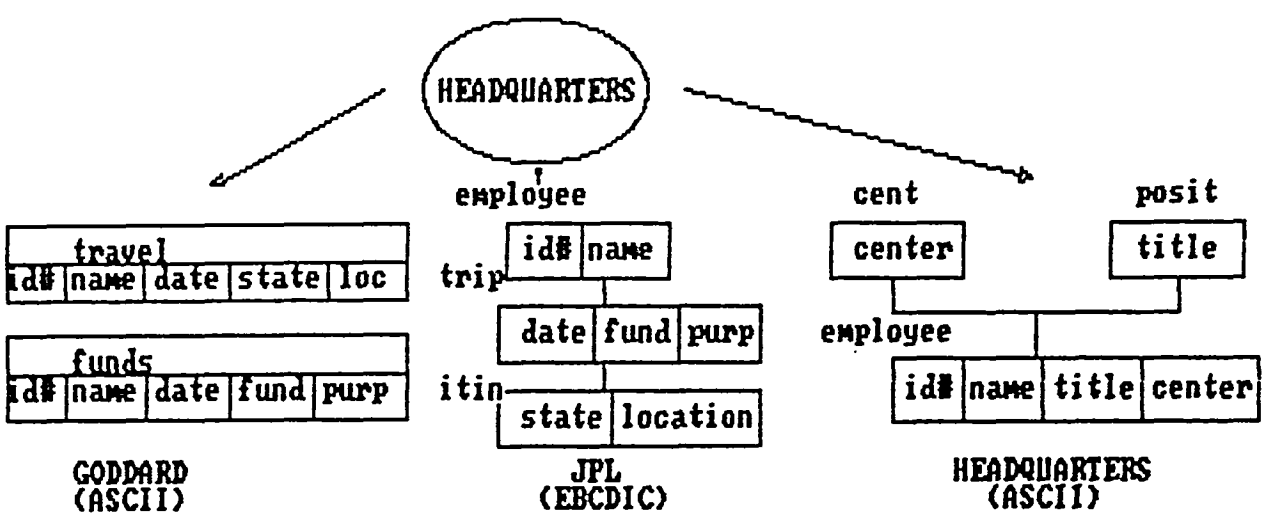
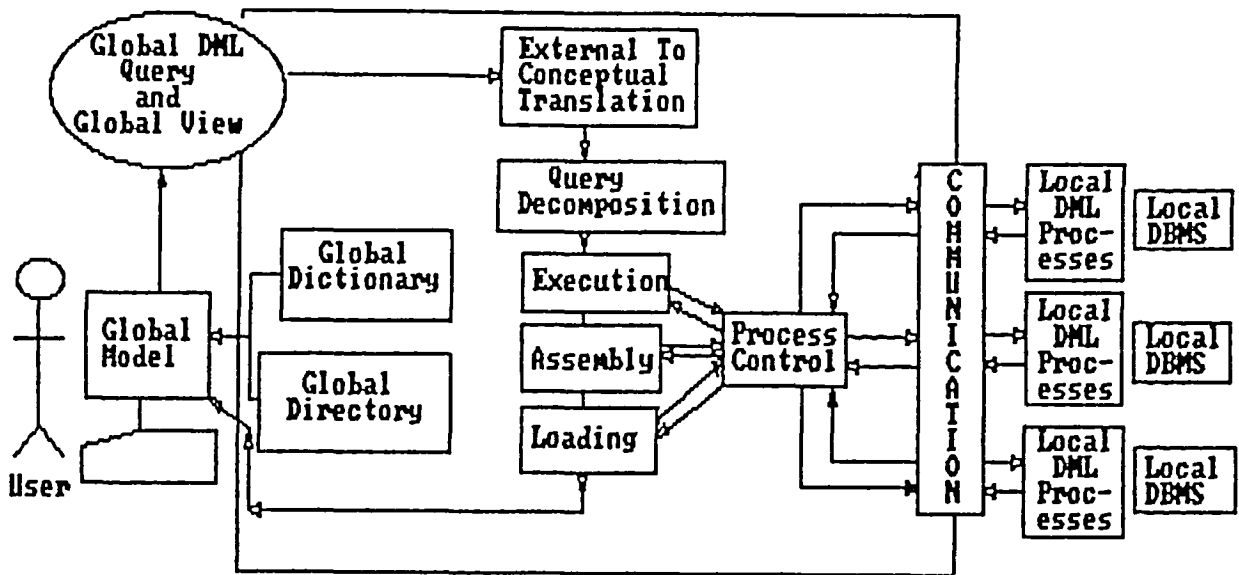

Figure 9-6



DISTRIBUTED HETEROGENEOUS DATABASES: THE GLOBAL DATA MANAGER

Figure 9-7. Distributed Heterogeneous Databases: The Global Data Manager.

- o Is a uniform "front-end" that can be placed on top of each of the participating data models.
- o It should capture enough of the features of the underlying models but not generate too large a loss in performance.
- o It should not only be used as a front-end for the databases, but also as a front-end for the data dictionary and data directory.

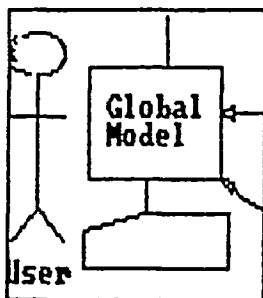

Figure 9-8. The Global Model.

travel					funding				
id#	name	date	state	loc	id#	name	date	fund	purp
1111	jones	3.12	calif	jpl	1111	jones	3.12	sk46	---
2222	smith	4.23	texas	jsc	2222	smith	4.23	fj55	---
3333	green	3.28	calif	arc	3333	green	3.28	rk44	---

In database logic, relational databases appear the same way to the user.

Figure 9-9. The Relational Database at GSFC.

employee						
id#	name	trip			itinerary	
		date	fund	purp	state	locat
4444	White	trip			itinerary	
		6.28	rf45	---	calif	arc
					calif	jpl
5555	Smith	trip			itinerary	
		7.13	sk44	---	md	gsfc

In database logic, databases appear as "tables within tables."

Figure 9-10. The Hierarchical Database at JPL.

cent				
center	employee			
	id#	name	posit	center
goddard	employee			
	1111	jones	prog	gsfc
	2222	smith	scient	gsfc
	3333	green	prog	gsfc
jpl	employee			
	4444	white	prog	jpl
	5555	smith	scient	jpl

posit				
title	employee			
	id#	name	posit	center
prog	employee			
	1111	jones	prog	gsfc
	3333	green	prog	gsfc
	4444	white	prog	jpl
scient	employee			
	2222	smith	scient	gsfc
	5555	smith	scient	gsfc

In data base logic the user sees the data base as "tables within tables."

Figure 9-11. The Network Database at NASA Headquarters.

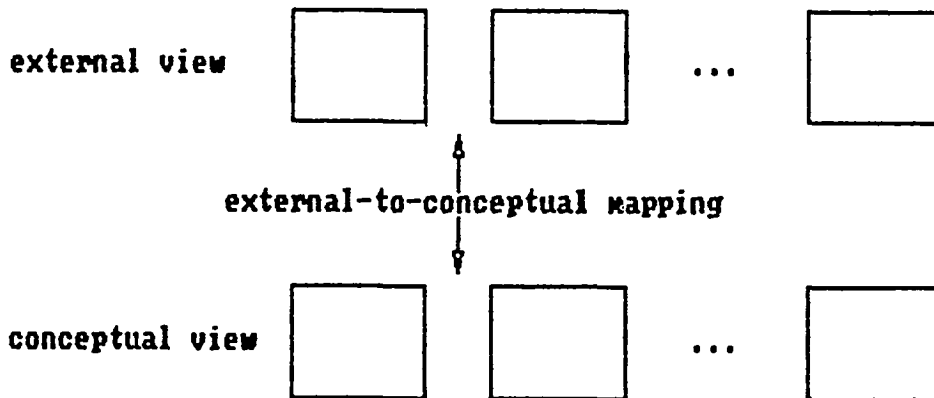

- o External views can provide classes of users with their own "view" of a data base.
- o External views can facilitate user queries.

Figure 9-12. External View of a Conceptual View.

travel					funding				
id#	name	date	state	loc	id#	name	date	fund	purp
1111	jones	3.12	calif	jpl	1111	jones	3.12	sk46	—
2222	smith	4.23	texas	jsc	2222	smith	4.23	fj55	—
3333	green	3.28	calif	arc	3333	green	3.28	rk44	—
4444	white	6.28	calif	arc	4444	white	6.28	rf45	—
4444	white	6.28	calif	jpl	5555	smith	4.22	hj55	—
5555	smith	4.22	md	gsfc					

- o The conceptual view is made up of the data bases from Goddard and JPL.
- o All values are in ASCII to the user.

Figure 9-13. An Example of an External View.

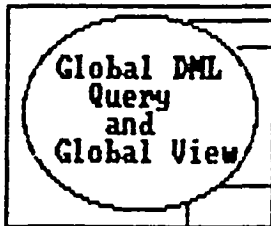

- o The user's global view is the data base that the user can imagine is actually located on the computer on which he/she resides.
- o The global view is often made up of the union of different views.
- o If data types differ (say, EBCDIC to ASCII) the user can pretend that all types are the same, say ASCII, and let the system deal with the conversion.

cent				
center	employee			
	id#	name	title	center

travel				
id#	name	date	state	loc

Figure 9-14. The User's Global View.

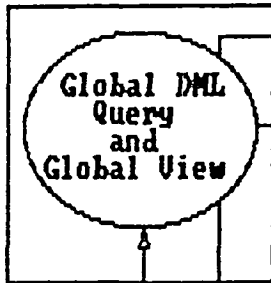

- o The global data manipulation language (DML) is a uniform language for operating on all of the databases.
- o The global DML can also be used to query the data dictionary and data directory.
- o The global DMLs fall into two classes- non-procedural DMLs and procedural DMLs.

Figure 9-15. Global Data Manipulation Languages.

```

select cent-employee.id#, cent-employee.name,
       cent-employee.title
from cent-employee, travel
where  state=calif
and   cent-employee.id#=travel.id# ;

```

cent				
employee				
center	id#	name	title	center

travel				
id#	name	date	state	loc

Figure 9-16. Generalized SQL DML.

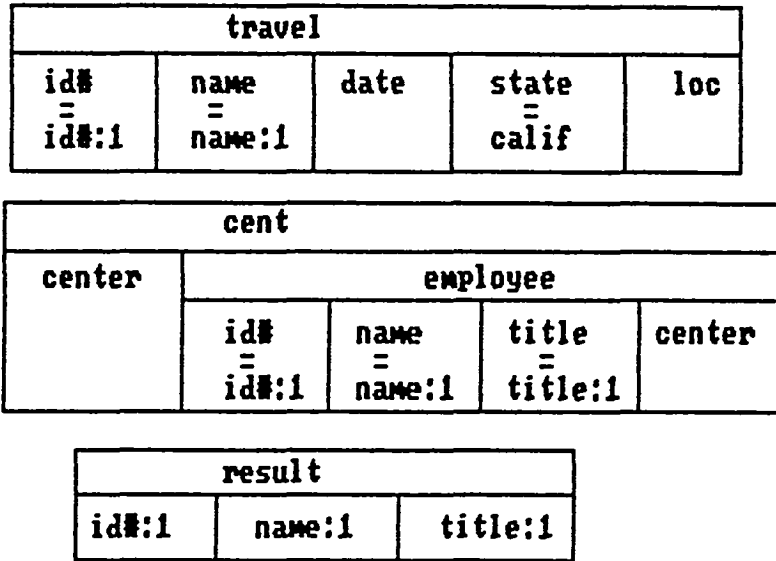

Figure 9-17. Generalized QBE DML.

```

get w (id#:1, name:1, title:1):
  (E)date:1...(E)center:1
  travel(id#:1,name:1,date:1,calif,loc:1)
  & cent-employee(center:1,employee:1,id#:1,name:1,title:1,center:1);

```

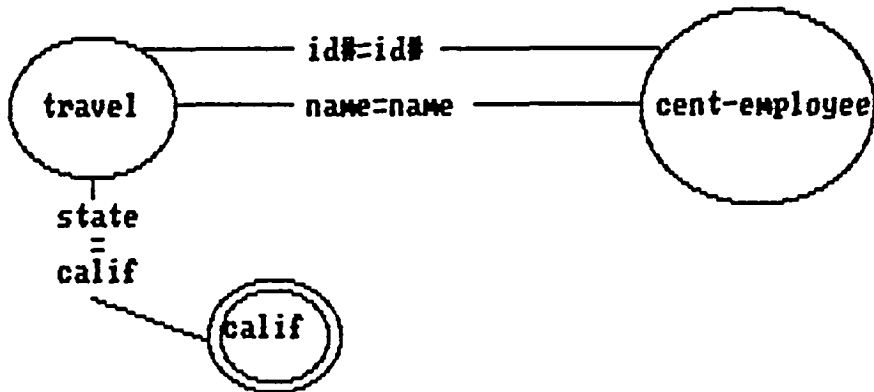

Figure 9-18. Generalized Calculus (GCALC) DML.

dictionary							
key_word	definition				conversions		
	field	record	view	semantics descr	type	domain	range

directory								
view	a-v	schema		language			constraints	
		table	rule	clusters	predicts	functions	cluster	lft

ext-conc-mappings									
mapping	ext-view	conc-view	coding		defining formulae			implied constr.	
			etpe	code	#	argu	defin #	conjunct	#

Figure 9-19. Global Dictionary/Directory.

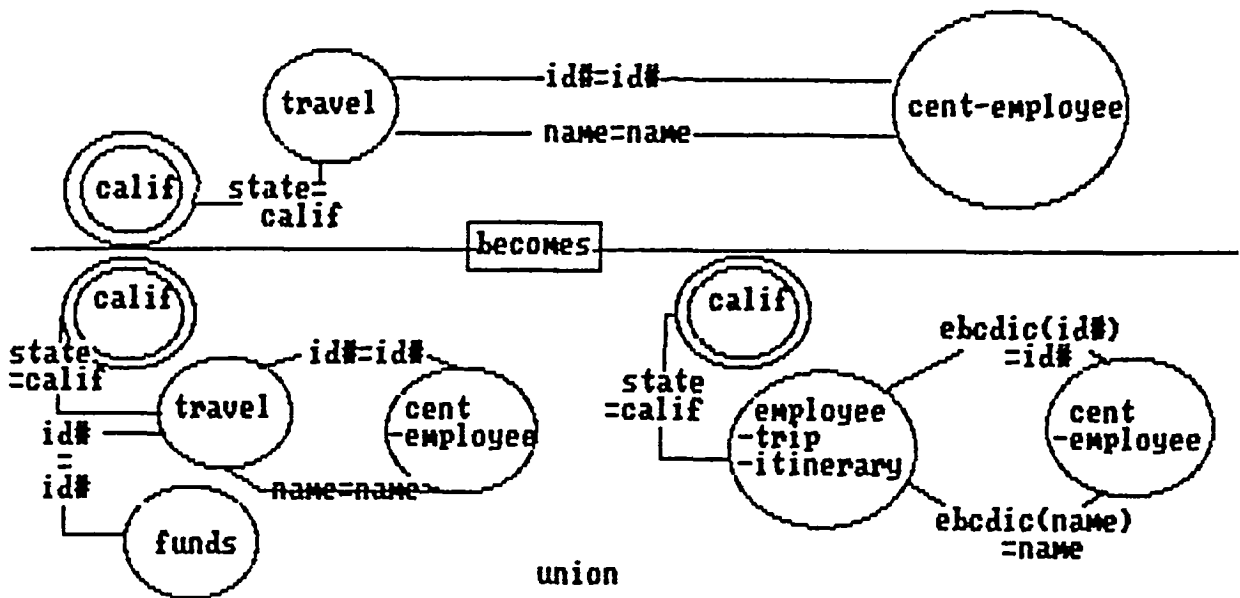

Figure 9-20. External-to-Conceptual Translation.

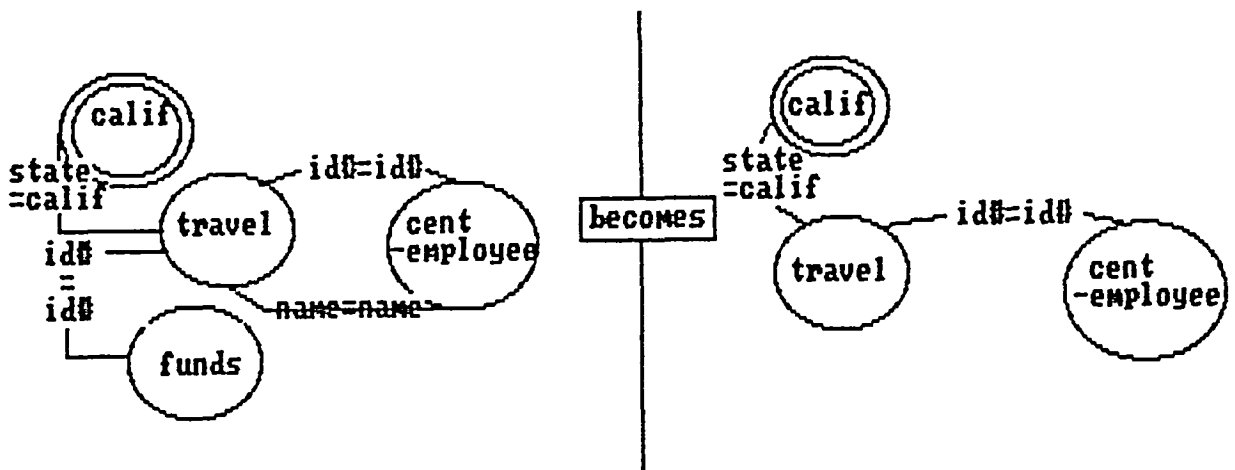

Figure 9-21. Logical Optimization.

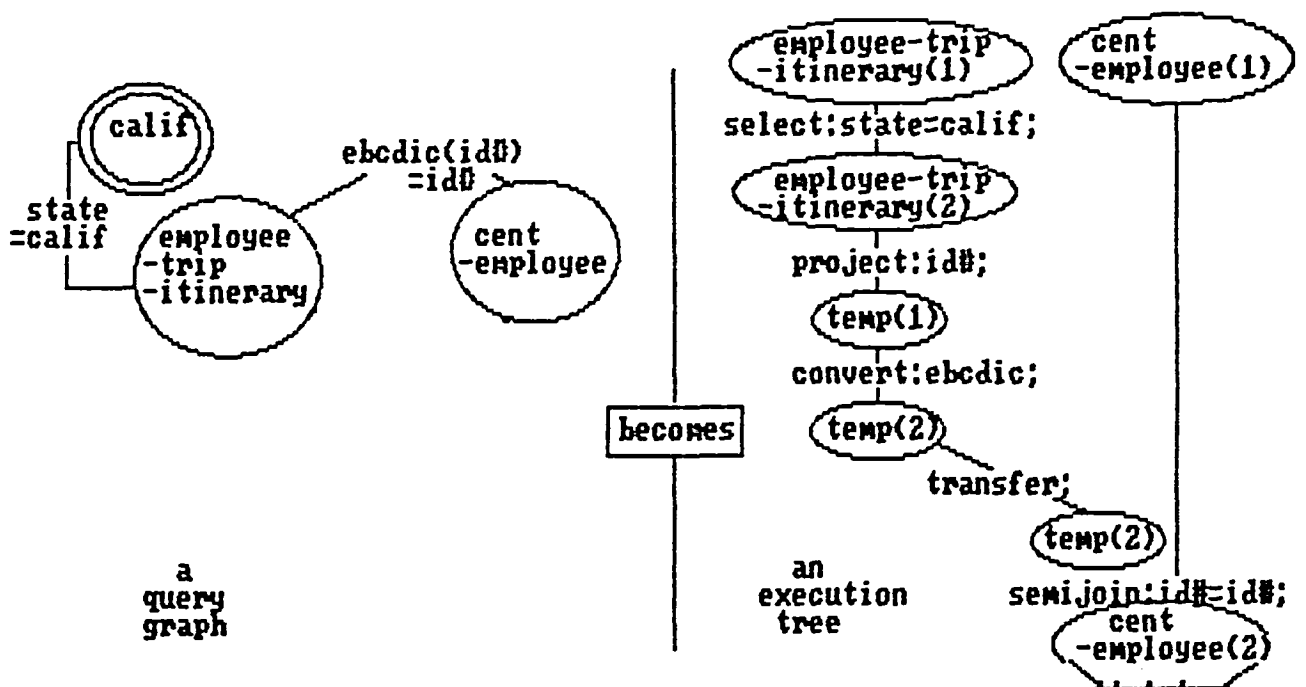

Figure 9-22. Query Decomposition.

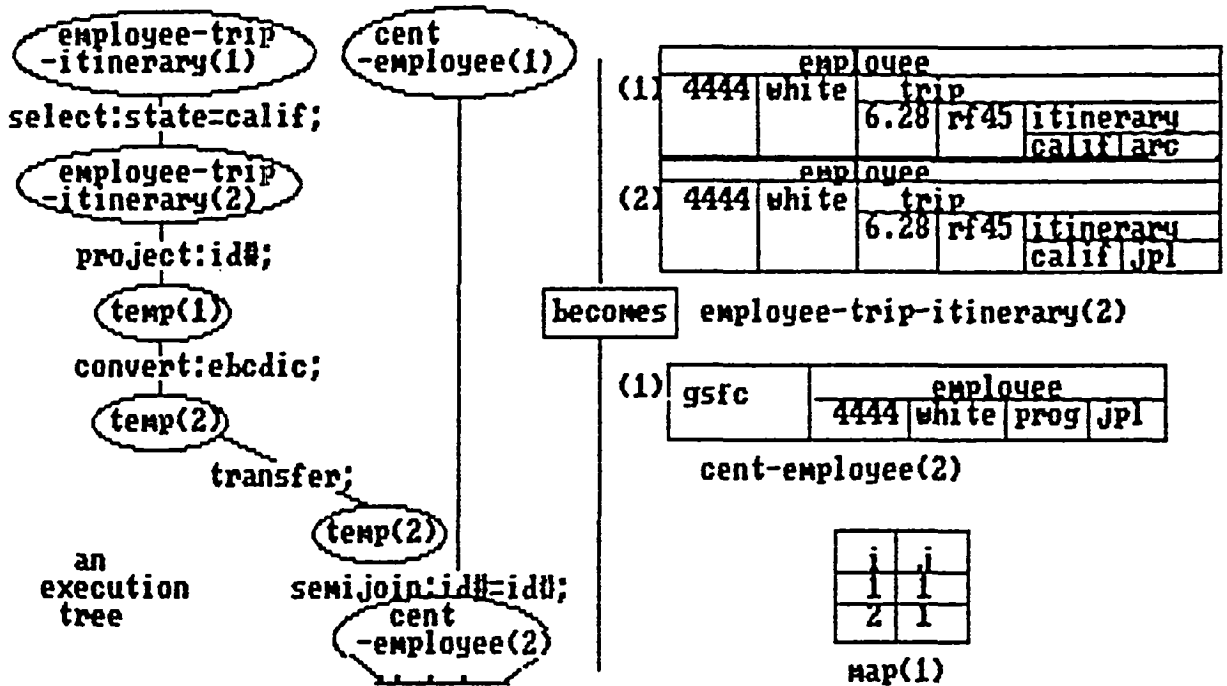

Figure 9-23. Execution.

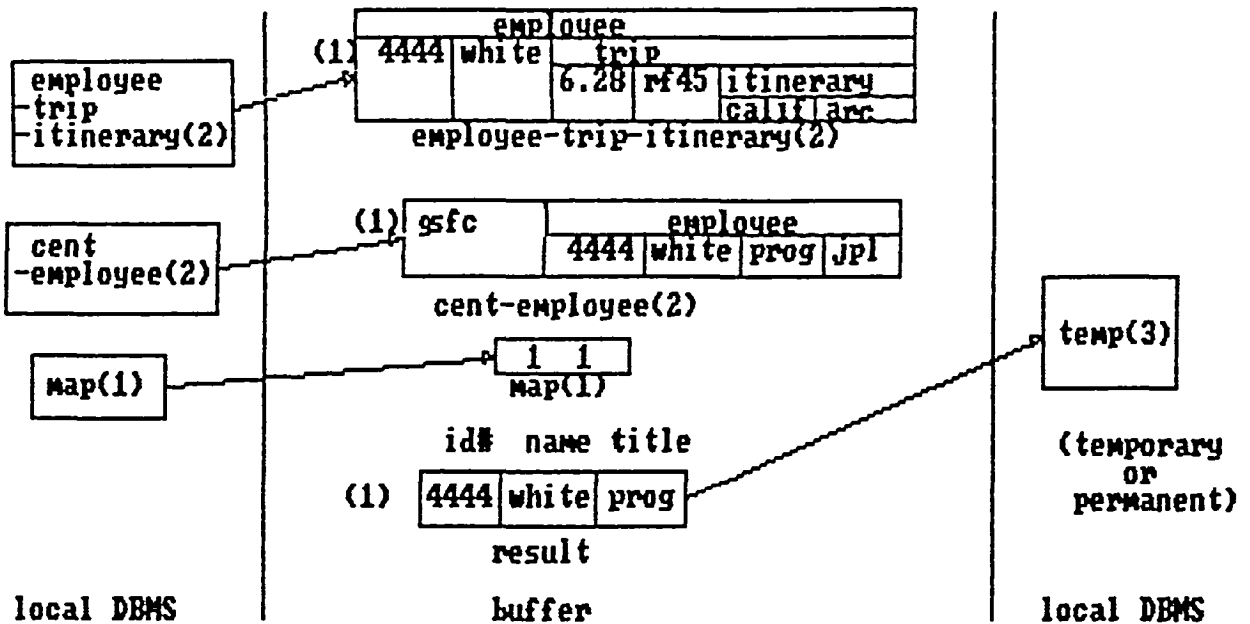

Figure 9-24. Assembly.

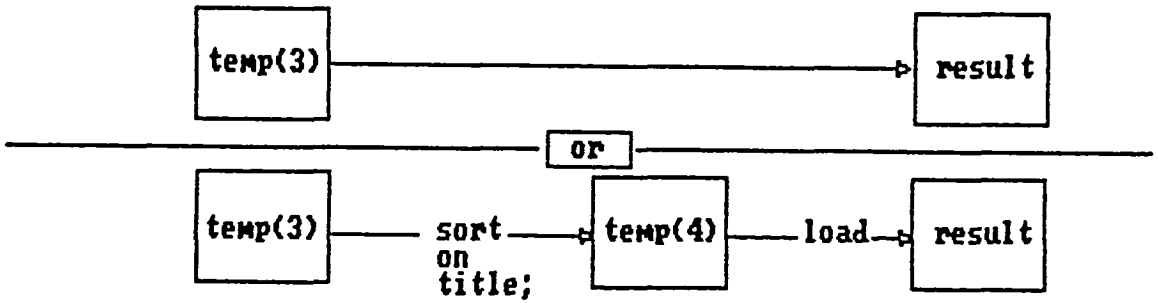
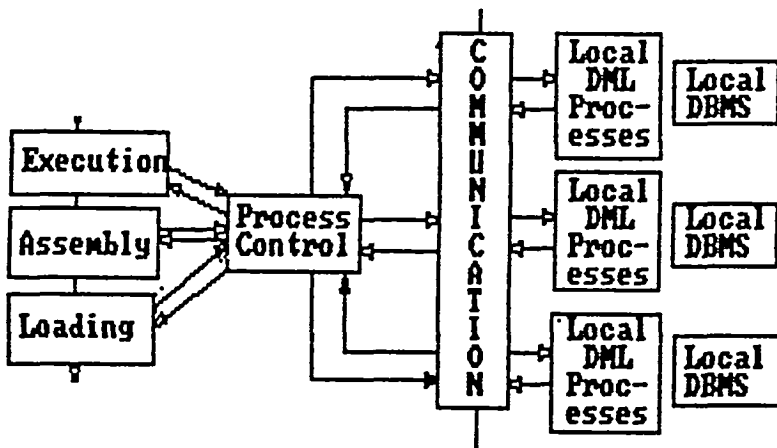

Figure 9-25. Loading.



- o Many queries are being handled simultaneously.
- o Both process commands and data are regarded as "messages" that are being transferred between nodes.
- o Queries which appear to yield no answer are killed.
- o Communication breakdown has to be suitably handled.

Figure 9-26. Process Control and Communication.

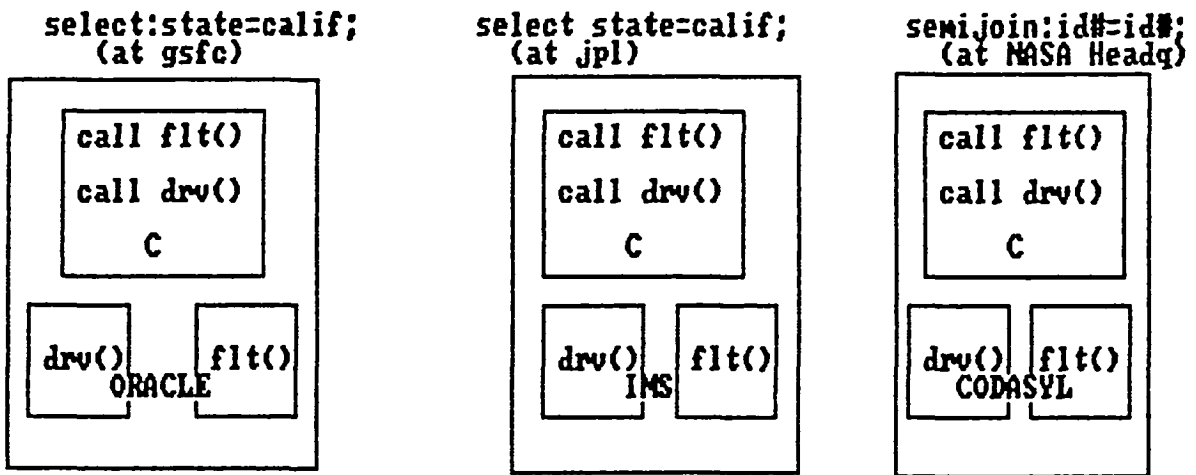

Figure 9-27. Local DML Processes.

The development of the Global Data Manager is being coordinated by the Information Management Branch at GSFC. Participating universities include:

- o The University of Maryland
- o The Catholic University of America
- o Towson State University
- o Stevens Institute of Technology
- o The City University of New York

Figure 9-28. Research in Progress.

o DAVID (Distributed Access View Integrated Database) System is based on the recently developed framework called database logic.

o Its purpose is to enable users to easily access databases which are heterogeneous and physically distributed.

o Our modus-operandi is simple. We generalize the relational approach to the heterogeneous approach using database logic as our vehicle.

o Further details can be found in "APPLIED DATABASE LOGIC II: HETEROGENEOUS DISTRIBUTED QUERY PROCESSING" PRENTICE-HALL (EXPECTED JAN. 1984).

Figure 9-29. Summary.

10. NASA SCIENTIFIC AND TECHNICAL INFORMATION SYSTEM (STI) AND
NEW DIRECTORY OF NUMERICAL DATA BASES

John Wilson
Headquarters Code NIT

Those of us who have responsibility for it, in all modesty, think that NASA's STI System is the biggest, most agile, best managed, and most useful collection of aerospace information in the world. The total system includes the facility out at the Baltimore-Washington Airport; the parallel facility run for us by the AIAA in New York City; the STI Branch in Washington, the minisystems constructed at each of the NASA Centers and contractor sites; and arrangements with the European Space Agency for inputting reports of member nations and access to the data base. The STI Branch in Headquarters has existed for more than 20 years.

Looking at the NASA-wide technical information system, we immediately spot the inconvenient fact that each Center's STI operations are organized differently. In all NASA and JPL about 200 civil-service people and 350 support-service contractors work in technical information. They are supported altogether by funds in excess of \$30 million annually.

At the heart of the system is the collection, a huge body of scientific and technical information collected from worldwide sources. It's big--currently containing over 2.2 million individual items. It's also dynamic, growing at the rate of 140,000 items per year. We have a number of quality-control and filtering methods to keep this massive data base from turning into a squirrel's nest. Principal elements in this data base are reports, journal papers, presentations, and books. If it's been put on paper or film, and if it's on NASA's mission and given any reasonable degree of release, we ought to have it.

What we do with this tremendous collection is what the system is all about. It's fairly easy to microfilm the documents and distribute them promptly to Centers and contractors. There are at least a dozen different ways we assemble and parcel out specific slices for individuals and groups of users. We issue two abstract journals, on alternating weeks, that announce and abstract new material, one for reports, and one for journal papers and books. Both of these journals, Scientific and Technical Aerospace Reports (STAR) and International Aerospace Abstracts (IAA), carry indexes that allow a user to search by subject, author, originating institution, contract number, or report number. They are produced rapidly and permit about as sophisticated search and retrieval as can be managed by ink on paper!

But these journals, even with a set of cumulated indexes, are really neither fast enough or comprehensive enough to suit many NASA needs. Typically, when a searcher wants to know what's been done in a specific area, he wants to know a little more than simply what's been done recently. There is a great deal of serendipity in a really satisfactory search: it's a kind of random walk into unknown terrain. For this, nothing to date has proved better than our NASA/RECON, an online bibliographic search system of almost eerie responsiveness. NASA pioneered with this system in the 1960s and 1970s; in the intervening period RECON has been steadily growing in responsiveness, speed, and precision. RECON currently responds to over 12,000 separate commands a day, most of them from over 250 terminals and password holders.

One interesting part of RECON is NALNET, containing a listing of journals and books held by each NASA Center library. This means that our libraries need not maintain costly duplicate collections for local use but can arrange for

rapid interlibrary loans of titles on demand.

There are countless by-product advantages of our methods of accessing the collection. To produce the big abstract journals, for example, we need standardization citations, abstracts, and indexing. To re-sort this material into specialized products for special audiences, all it takes is some relatively uncomplicated software. It permits us to generate, at low cost and without delay, continuing bibliographies in aeronautical engineering, aerospace biology and medicine, earth resources and energy, large space structures technology, and management. Note that this material, sorted from the main input stream and presented for particular readerships, is acquired at virtually zero incremental cost and effort.

We also assist Headquarters offices in devising or producing their own special data bases and publications including the RTOP (on-going NASA R&D projects) annual, the yearly "green book" of university contracts and grants, the indexes of NASA management issuances, and a new online index for NASA safety reports. The Patent Bibliography is issued for the Patent Counsel.

DIRECTORY OF NUMERICAL DATABASES (DND)

A new service, the Directory of Numerical Databases (DND) is now accessible to engineers and scientists through online searching of the NASA/RECON system. DND is a referral listing of scientific and technical data bases which can be shared among NASA staff and contractors who have an interest in a specific technical data set. The DND provides a brief description of each listed data base and gives the name and phone number of a contact person from whom access details may be obtained.

Initially, descriptions of more than 140 data bases are provided, covering a broad range of technical fields in which NASA has an interest. The data bases listed in the DND were identified and described through the cooperation of all of the NASA Centers. Additional listings are being received, and the file is expected to grow in usefulness to the technical community as it becomes more comprehensive. This project is a part of an effort in NASA to improve the management of numerical data. Making information about that data more readily accessible will help assure that the maximum benefit is obtained from the dollars invested.

PROPOSED NASA-WIDE INTEGRATED LIBRARY SYSTEM

A NASA-wide Integrated Library System (ILS) is being developed for the Center libraries. The system will be composed of several subsystems:

- o Online Catalog
- o Acquisition Subsystem
- o Circulation Control Subsystem
- o Information Retrieval Subsystem
- o Management Information Subsystem
- o Authority File Subsystem

Each of the above subsystems will interact with online files which are identified as:

- o Bibliographic files
 - Documents
 - Books
 - Journals
- o Patron files
- o Vendor files

The proposed system will be modular in terms of both hardware and software. Other proposed requirements include but are not limited to expandable memory and direct memory address. The system must be capable of performing I/O through a variety of remote terminals consisting of high-speed CRT terminals and OCR or zebra label scanning devices. Initial storage requirements for the several files will consist of an estimated one hundred million characters of online storage with input at an estimated daily rate of 20,000 characters/day. The applications will also require the ability to off-load data for eventual archival use.

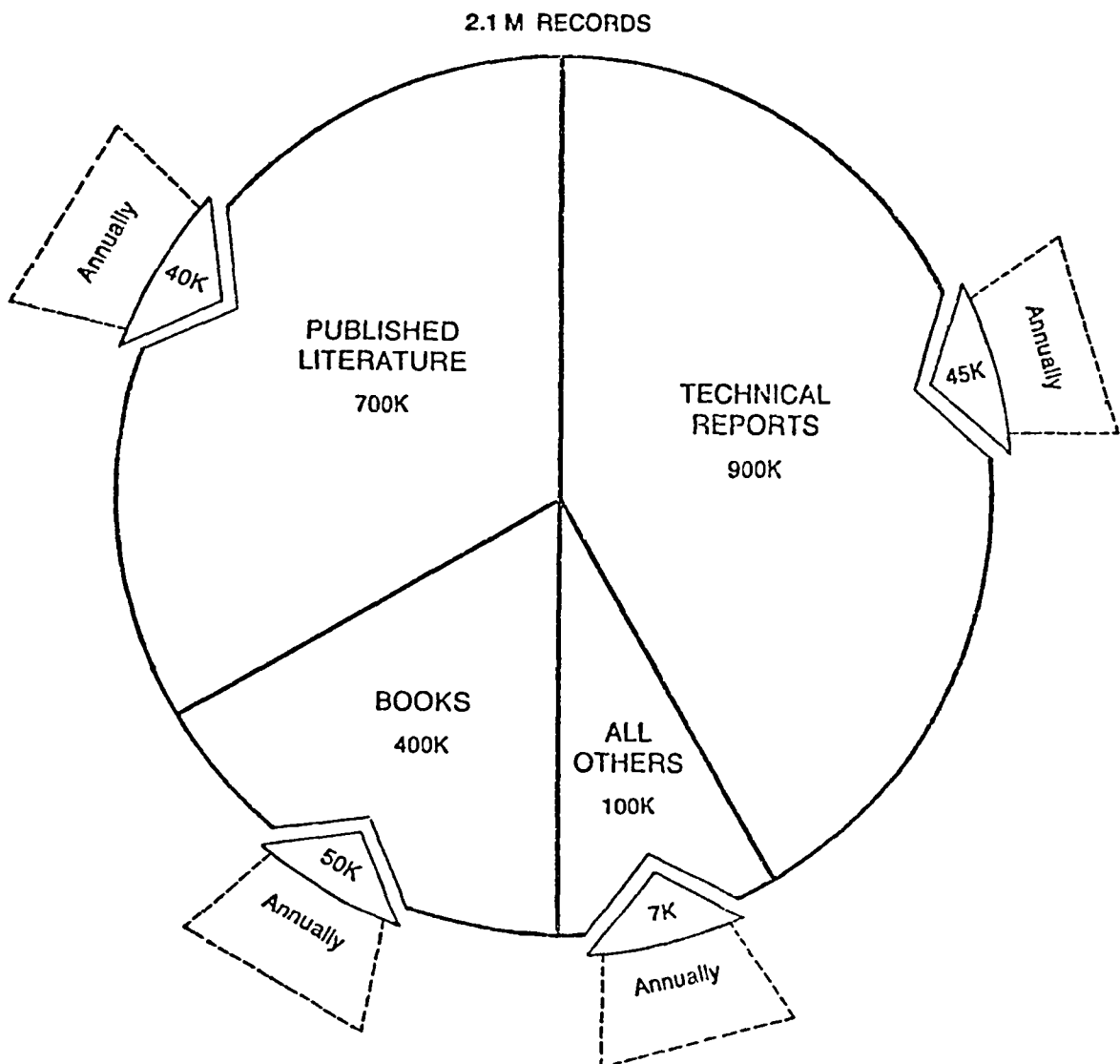

Figure 10-1. Nasa Facility Data Base.

UTTL: Experimental study on wavelength scaling in laser fusion by using 0.53, 1.06 and 10.6 micron lasers

AUTH: A/NISHIMURA, H.; B/AZECHI, H.; C/YAMADA, K.; D/IAMURA, A.; E/INADA, Y.; F/MATSUOKA, F.; G/HANADA, M.; H/SUZUKI, Y.; I/NAKAI, S.; J/YAMANAKA, C. PAA: J/(Osaka University, Osaka, Japan)
Osaka University, Technology Reports, vol. 31, Mar. 1981, p. 97-107.

MAJS: /*ABLATION/*ENERGY TRANSFER/*INFRARED ABSORPTION/*INFRARED LASERS/*LASER FUSION/*LASER PLASMA INTERACTIONS

MINS: / CARBON DIOXIDE LASERS/ ELECTRON ENERGY/ GLASS LASERS/ LASER TARGETS/ PLASMA ACCELERATION/ PLASMA TEMPERATURE/ X RAY SPECTROSCOPY

ABA: (Author)

ABS: Experimental studies of the wavelength dependence of several laser-plasma coupling processes were performed. These were: (1) laser light absorption, (2) energy transport, and (3) ablation and target acceleration behavior. At a laser intensity of around 10 to the 14th W/sq cm, the ablation process was dominated by heat transport due to cold electrons for 0.53 micron and 1.06 micron lasers and was dominated by hot electrons for the 10.6 micron laser.

Figure 10-2. Publication Typical Entry.

UTTL: Optical sensor for measurement of position and deformations of models in wind tunnel

AUTH: A/SURGET, J.; B/PHILBERT, M.; C/DUNET, G. PAA: C/(ONERA, Chatillon-sous-Bagneux, Hauts-de-Seine, France)
La Recherche Aeronautique (English Edition), no. 3, 1982, p. 43-51.

MAJS: /*FIBER OPTICS/*OPTICAL MEASURING INSTRUMENTS/*TRAILING EDGES/*WIND TUNNEL MODELS/*WIND TUNNEL TESTS

MINS: / CALIBRATING/ FLOW VELOCITY/ SENSORS/ WINGS

ABA: R.K.R.

ABS: The design of an optical position sensor produced to allow the localization of the trailing edge of a wing placed in a wind tunnel is presented. The instrument consists of the sensor itself, an electronic cabinet, and a control box. In calibrating the instrument, it is noted that dispersion of the location of the tip of the optical fiber never exceeded plus or minus 0.01 mm, and no apparent drift was detected. Validation was performed by comparing position indications obtained using an optical sensor and a mechanical feeler. Tests are performed at three flow velocities, and it is found that the device functions satisfactorily. The principal advantages of such a device include sensitivity, absence of drift, and ease of operation.

Figure 10-3. Journal Article Entry.

83N12345# ISSUE 3 PAGE 363 CATEGORY 33 RPT#: PB82-178989
NBSIR-81-1656 81/12/60 181 PAGES UNCLASSIFIED DOCUMENT
UTTL: NBS 30/60 Megahertz Noise Measurement System Operation and Service Manual
AUTH: A/COUNAS, G.; B/BREMER, T.
CORP: National Bureau of Standards, Washington, D.C. AVAIL.NTIS SAP: HC
A09/MF AC1
MAJS: /*ELECTROMAGNETIC NOISE/*MANUALS/*NOISE MEASUREMENT/*NUMERICAL CONTROL/*
RADIOMETERS
MINS: / CALCULATORS/ COAXIAL CABLES/ MAINTENANCE
ABA: Author (GRA)
ABS: The general theory of operation, operating procedures, and maintenance
procedures for an automated noise measurement system using a commercially
available desktop calculator as the controller are described. Calibration
of coaxial noise sources at 30 and 60 MHz using a total power radiometer
designed to operate under computer control is described. Use of the IEEE
488 instrument bus and structured software techniques allows substitution
of commercially available components with a minimum of hardware and
software modification.

Figure 10-4. Report Entry.

83K10001 (MOD-000) CNT#: NAS1-17213 DUN#: 066525775 CIC#:
1370642
National Aeronautics and Space Administration, Langley Research Center,
Hampton, Va.
Advanced Automation, Inc., Urbana, Ill.
UTTL: A feasibility study in, and planning for, application of advanced computer
AI monitoring and analysis techniques
UNCLASSIFIED NOVEMBER 5, 1982 / MAY 4, 1983
IM: A/SAMMS, K. H. A/246B
REPORTS EXPECTED
MAJS: /*AIRBORNE/SPACEBORNE COMPUTERS/*ARTIFICIAL INTELLIGENCE/*COMMERCIAL
AIRCRAFT/*COMPUTER PROGRAMMING/*COMPUTER TECHNIQUES/*IN-FLIGHT MONITORING
/*SIMULATION/*SYSTEM FAILURES/*WARNING SYSTEMS

Figure 10-5. Contract Entry.

83W76573 310-40-45
 UTTL: Mission Operations Technology
 SANFORD, R. G. 301-344-6138
 National Aeronautics and Space Administration, Goddard Space Flight
 Center, Greenbelt, Md.

The mission operations technology RTOP is a subsystem level RTOP, the objective of which is to transfer state-of-the-art hardware, software, and automation technology to the mission operations environment to improve operations efficiency and reliability and reduce costs. This RTOP is divided into two tasks: control center automation and distributed control research. The control center automation task seeks to develop a highly automated operations control center capable of supporting multiple simultaneous missions by the study and specification of the levels of automation for systems resource allocations, connection, test, and status reporting. The distributed control research task will provide the technology required for a workable distributed mission control environment by the development and implementation of a distributed command management software systems.

MAJS: /*AUTOMATIC CONTROL/*COMMAND AND CONTROL/*COMPUTER NETWORKS/*COMPUTER PROGRAMS/*COMPUTERS/*GROUND BASED CONTROL/*GROUND STATIONS/*MANAGEMENT/*ON-LINE SYSTEMS/*OPERATIONS/*SUPPORT SYSTEMS

Figure 10-6. RTOP Entry.

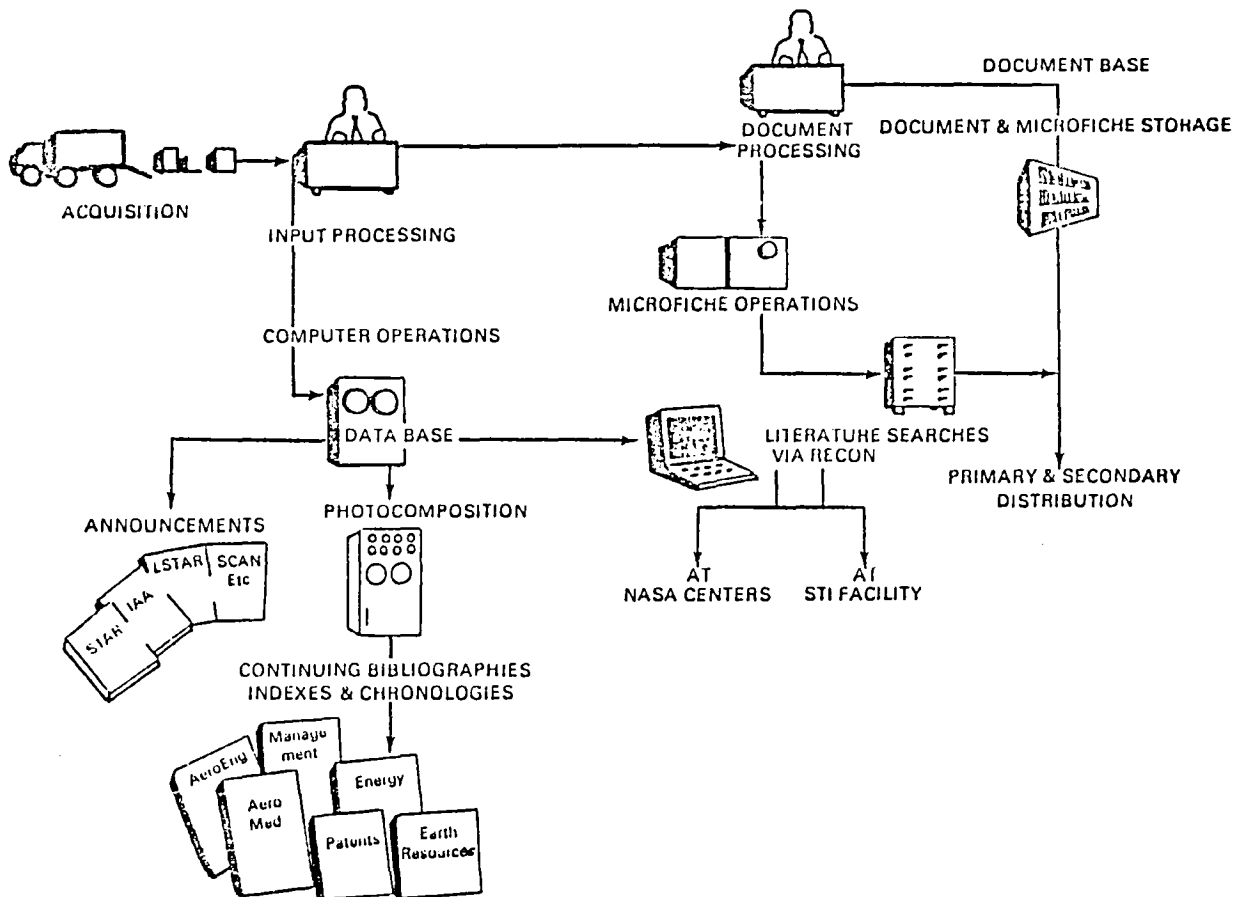

Figure 10-7. STI Facility Systems.

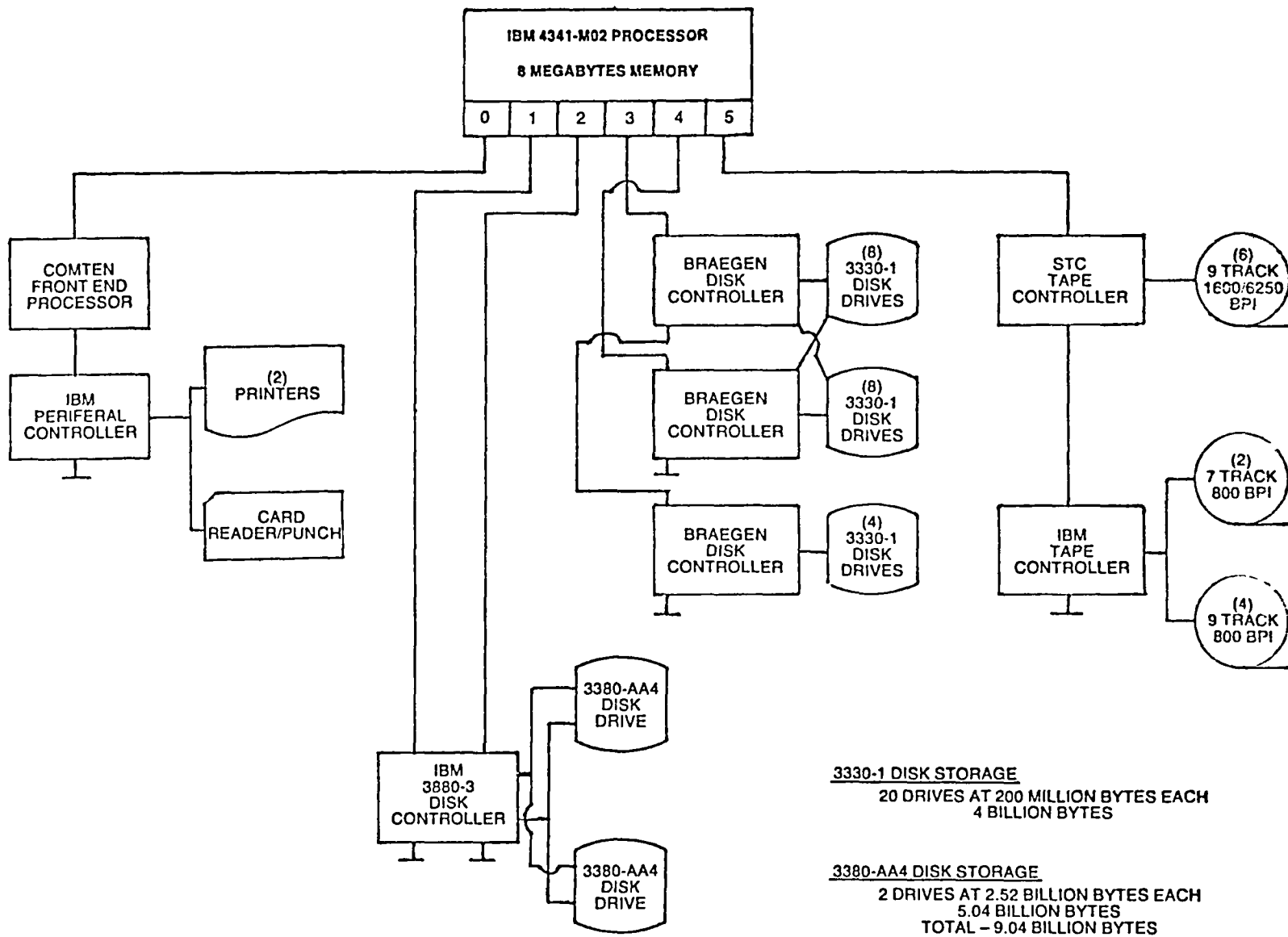

Figure 10-8

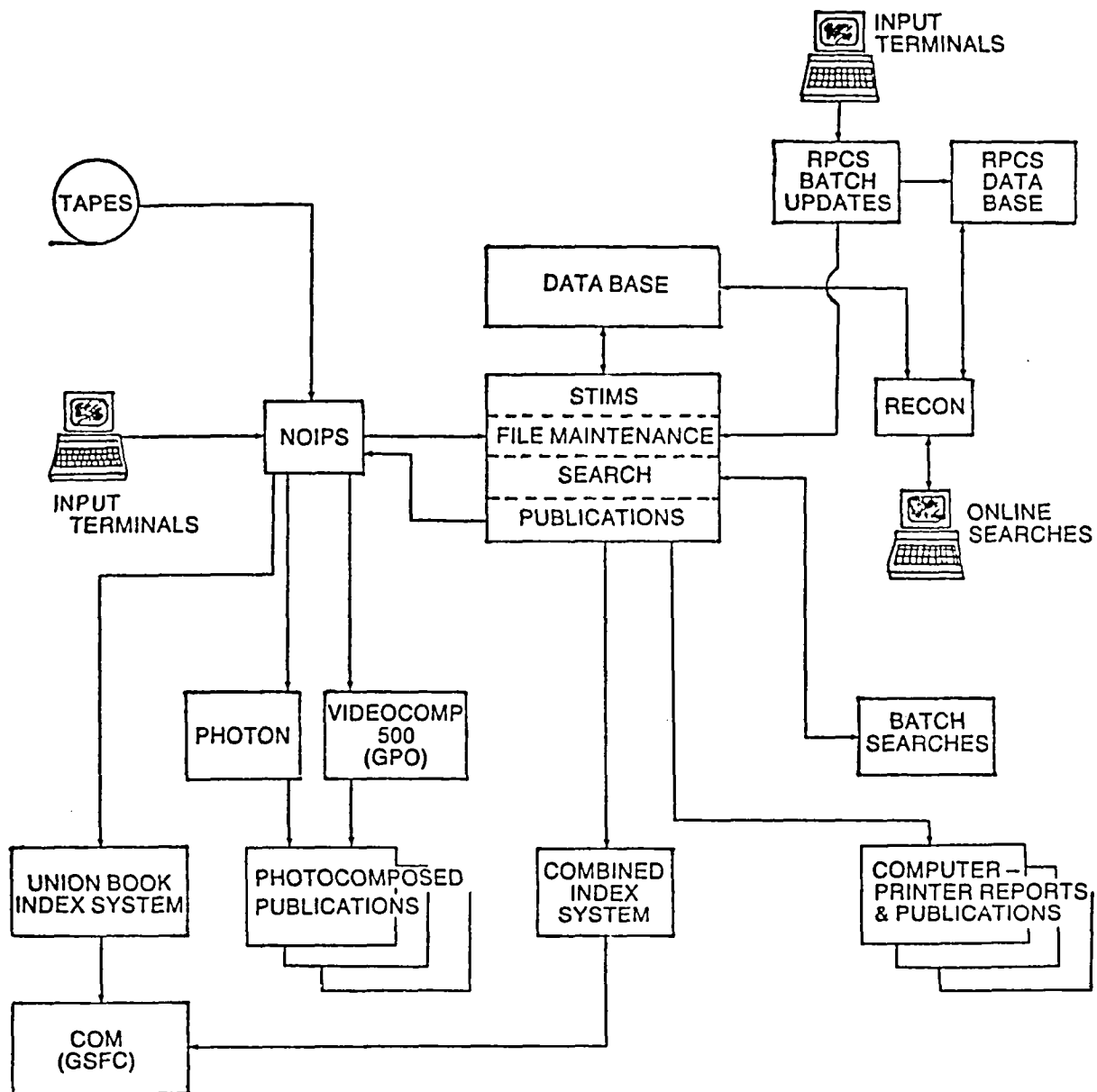
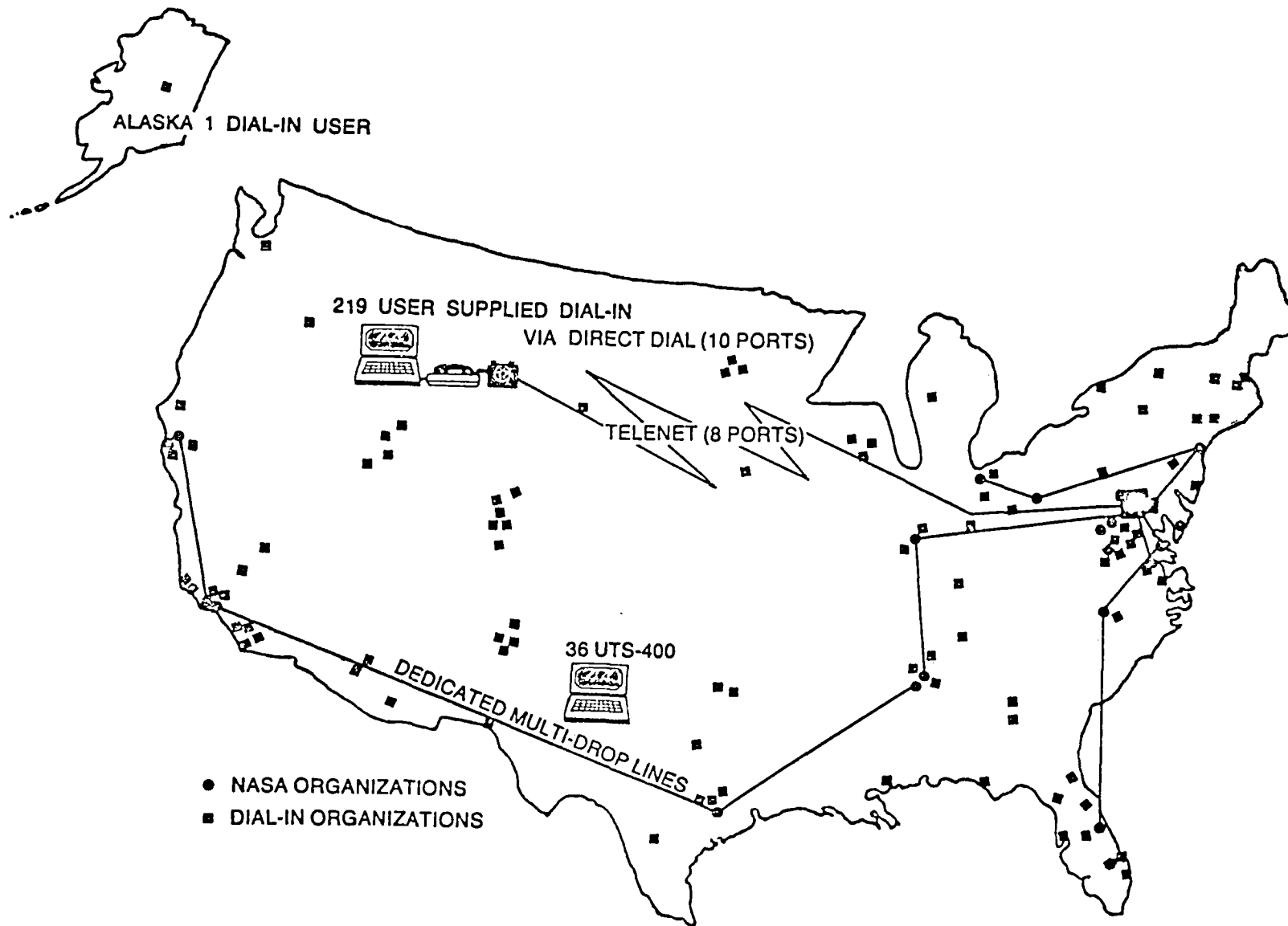

Figure 10-9. Major Software Systems Interfaces.



JANUARY 1983

Figure 10-10. NASA/RECON System.

83F10108
 Significant Wave Height (SEASAT A Altimete) (SWH/SA)
 DATABASE TYPE: NUMERIC
 GENERAL DESCRIPTION: Significant wave height was derived from an analysis of return waveforms of the reflected microwave pulse. The derived values are in meters. The SEASAT A Altimeter data were processed to provide geophysical and sensor files. The geophysical files contain significant wave heights, mean sea surface elevations, and wind speed. The sensor files contain primary measurements and include significant wave heights with derived engineering units which give the shape of the return pulses.
 DATA QUALITY: Geoid agreement was shown with independent observations from buoys, underflying aircraft and from the Gulf of Alaska SEASAT Experiment (GOASEX). The attained accuracy is + or - 38 cm for significant wave height less than 5m and perhaps for significant wave height less than 8 m; and + or - 1 m for significant wave height less than 10 m. OUTPUT PRODUCTS: The SEASAT A Altimeter data set is available in two forms on 9-track, 1800 and 1600 bpi computer compatible tape. The Sensor Data Records (SDR), Level I, contain engineering data and the results of onboard processing: orbit information, time of observation; waveforms, nadir range, significant wave height, and ocean backscatter. The Geophysical Data Records (GDR), Level II, were obtained by processing the SDR. They contain measured nadir range, list of applied corrections, including tied corrections, sea surface elevation, position (latitude and longitude), geoid information, significant wave height, and wind speed.
 DATA COLLECTION METHOD: SEASAT A Altimeter
 KEYWORDS: /*BACKSCATTERING/*ELEVATION/*GEOIDS/*OCEAN SURFACE/*OCEANOGRAPHIC PARAMETERS/*RADAR MEASUREMENT/*RADAR RANGE/*RADIO ALTIMETERS/*SEA LEVEL/*SEASAT PROGRAM/*SEASAT 1/*WIND VELOCITY
 TIMESPAN: 780707 - 781010
 AREA COVERED: The SEASAT A Altimeter obtained data between + or - 72 deg on 1400 orbits, with an orbit-track separation at the equator of 20 km to 50 km. SPATIAL/TEMPORAL RESOLUTION: Along the suborbital track, data were collected every millisecond from circular patches of sea surface 2.4 km to 12 km in diameter. The footprints are 2.4 km to 12 km wide and 0.6 km to 6 km longer in the orbit direction. Repeat observations were made where orbits crossed; selected orbits were repeated 9 times at 3-day intervals.
 NASA CENTER: National Aeronautics and Space Administration, Goddard Space Flight Center, Greenbelt, Md.
 CONTACT: Eugene R. Hoppe, NOAA/SDSD, World Weather Building, Washington, D.C. 20233, 301-763-8111
 DATA SOURCE: National Aeronautics and Space Administration, Wallops Flight Center, Wallops Island, Va.
 PROGRAM: SEASAT A Satellite
 DOCUMENTATION: Information Management Branch, GSFC, 1982, NASA Climate Data Catalog. U.S. Department of Commerce, Satellite Data Services Division. Satellite Data Users Bulletin, Vols. 1.1, 1.2, 2.2. OAO Corporation, 1981. SDSD First Level Catalog System, Technical Report No. OAO/SD-81/0007.
 COMMENTS: The SASS, SMMR, and Vrrr instrument data sets from SEASAT and the GEOS 3 Altimeter data set provide related data.
 NASA/NON-NASA: NASA
 CAT. CODE: 43 SECURITY CLASS: UNCLASSIFIED
 DATE RECEIVED: 820206

Figure 10-11. Typical Entry, Directory of Numerical Data Bases.

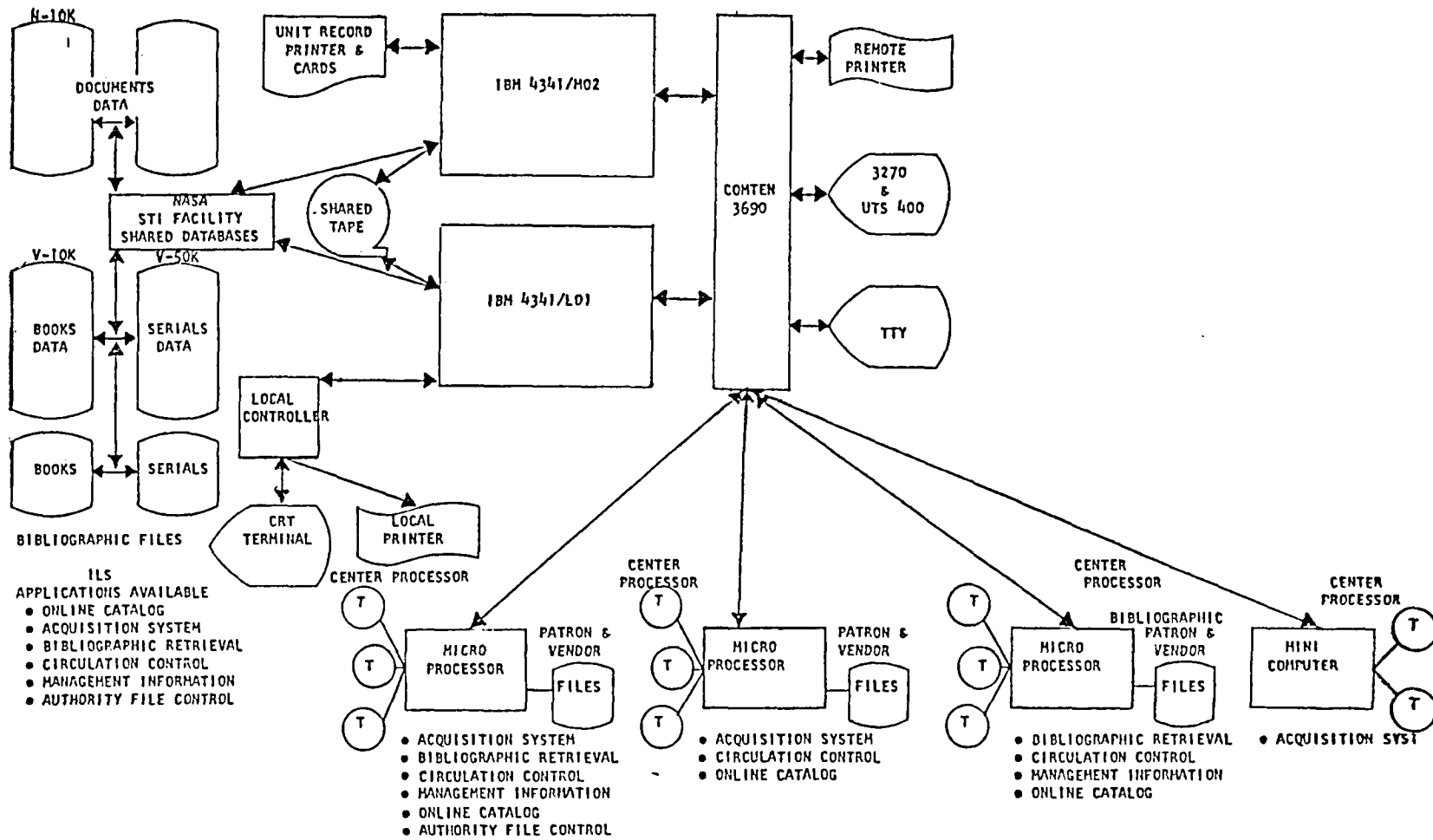

Figure 10-12. Conceptual Overview of the NASA-Wide Integrated Library System.

- MINICOMPUTER

- MULTI-USER OPERATING SYSTEM
- STAND ALONE SOFTWARE MAINTAINED BY NASA CENTER
- 3270 INTERACTIVE TRANSACTION PROCESSING
- RJE/RJO (2780/3780) DATA TRANSFER
- \$150,000 TO \$300,000 COST PER CENTER
- AVOIDANCE OF ADDITIONAL COSTS FOR MISSING FUNCTIONS, \$50,000 EACH

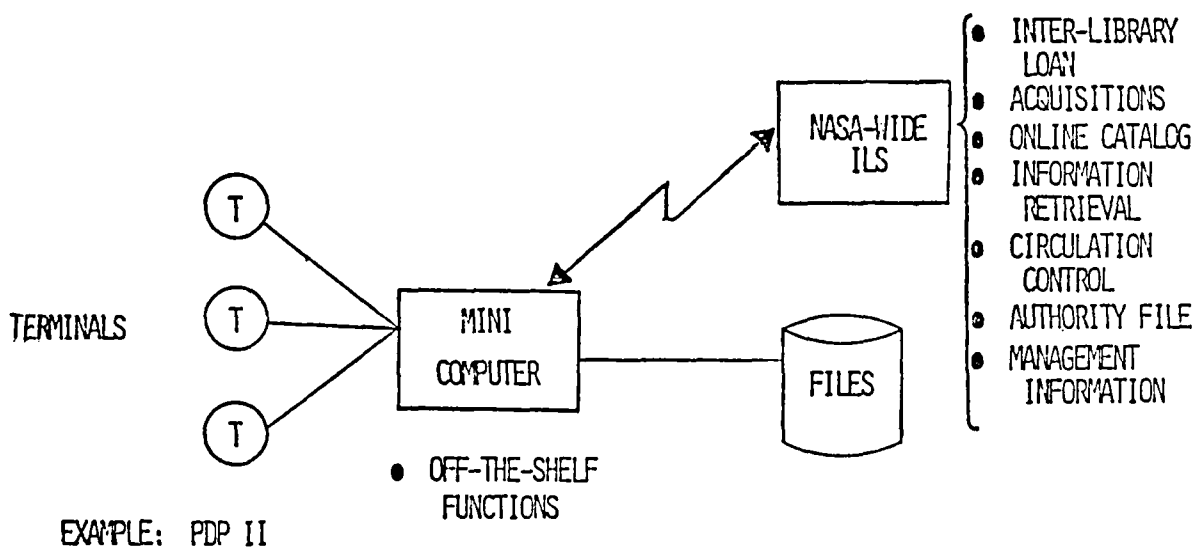
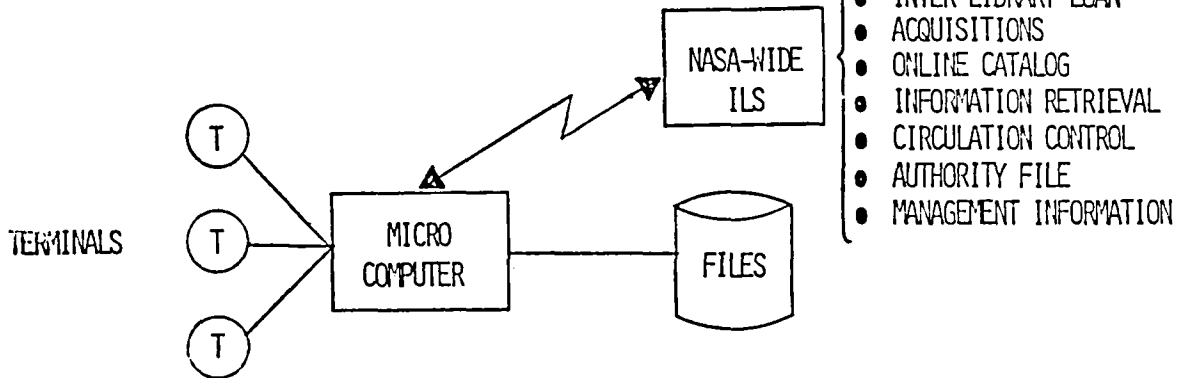

Figure 10-13. Model Participating Library Configurations.

- MICROCOMPUTER

- CP/M OR MP/M OPERATING SYSTEM
- SOFTWARE DOWN LINE LOAD OR ALTERNATE TRANSFER
- 3270 INTERACTIVE TRANSACTION PROCESSING
- RJE/RJO (2780/3780) DATA TRANSFER
- \$10,000 TO \$15,000 COST PER WORK STATION
- SYSTEM SAVINGS \$200,000 EACH CENTER



EXAMPLE: CROMEMCO, APPLE LISA, IBM PC II

- STAND ALONE TERMINAL

- 3270 INTERACTIVE TRANSACTION PROCESSING
- SOFTWARE COMPLETELY AT NASA-WIDE ILS
- ALA CHARACTER SET
- \$6,000 COST PER WORK STATION
- SYSTEM SAVINGS \$100,000 EACH CENTER

EXAMPLE: TELEX

Figure 10-13. Model Participating Library Configurations (Continued).

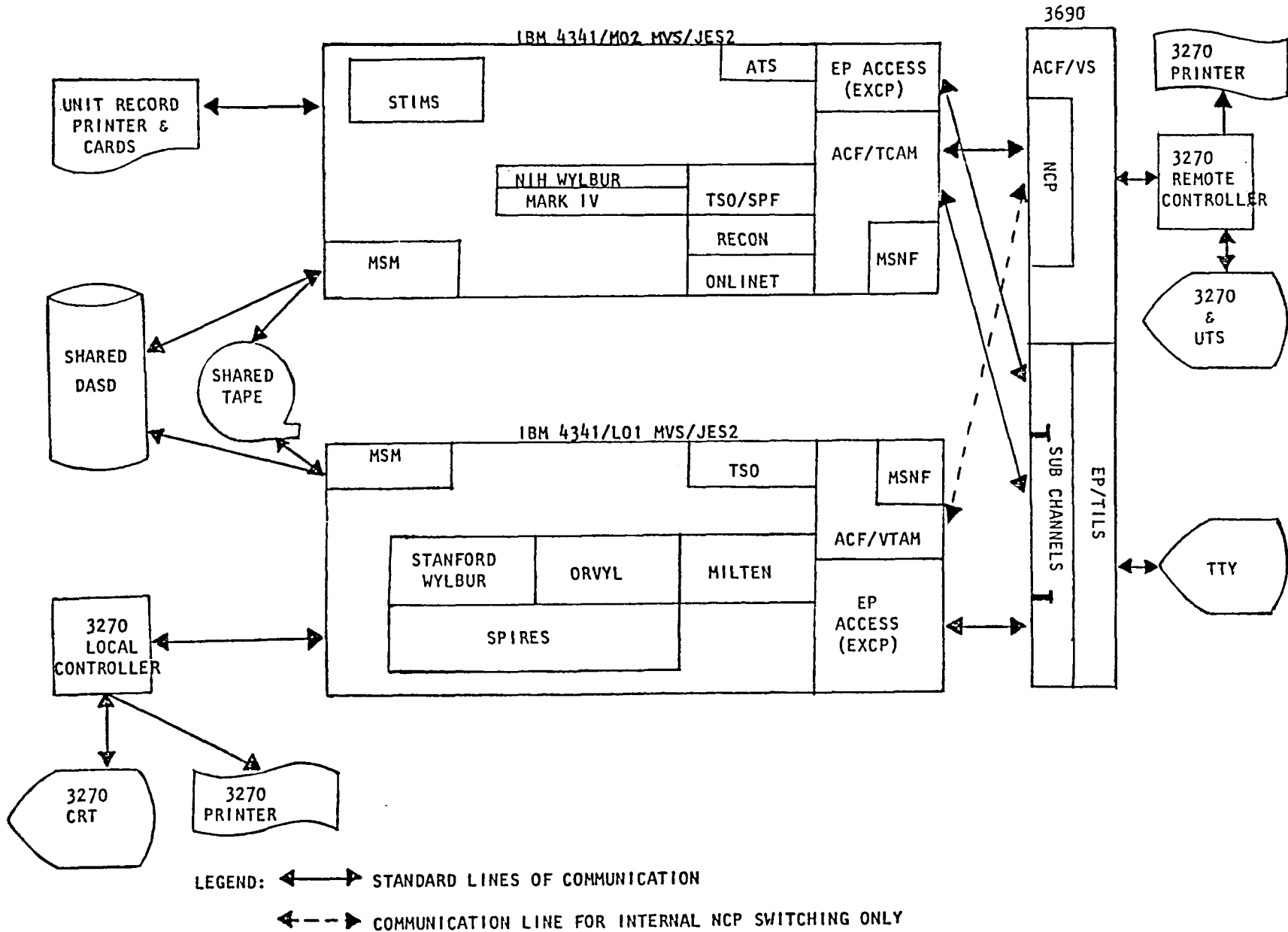

Figure 10-14

11. SPECIFICATIONS FOR A FEDERAL INFORMATION PROCESSING STANDARD DATA DICTIONARY SYSTEM

Alan Goldfine
Institute for Computer Sciences and Technology
National Bureau of Standards

1. INTRODUCTION

As the world's largest user of information processing technology, the Federal government is highly dependent on the use of this technology for carrying out government-wide programs and delivering essential services. Accordingly, data management software is a tool of rapidly increasing importance that merits special attention in its acquisition and use. The Institute for Computer Sciences and Technology (ICST) is addressing the need for standards and guidelines in this area in its Data Management Program.

A key software component for the management of information resources is the Data Dictionary System (DDS). A data dictionary system is a computer software system that provides facilities for recording, storing, and processing information about an organization's significant data and data processing resources.

ICST is developing a Federal Information Processing Standard (FIPS) Data Dictionary System. The FIPS DDS will be a software specification that Federal agencies may use in the evaluation and selection of DDSs. These specifications will not require an agency to use a data dictionary or to use one in a prescribed manner.

Federal agencies use DDSs to:

- inventory their data resources
- support the system development life cycle
- inventory computer equipment and software
- support data element and documentation standardization
- provide a directory to locate data in centralized or distributed environments

Given this usage, a FIPS for a Data Dictionary System will benefit agencies by:

- providing standard specifications that can be used in the selection, evaluation, and procurement of DDS software
- aiding in the portability of both DDS software and DDS data
- supporting portability of acquired skills, since agency personnel will not need to learn a new user language to use another DDS

2. THE NATURE OF THE FIPS

To supply the flexibility needed by all the widely differing applications and environments in the Federal Government, the FIPS will specify a "core" DDS together with a set of optional modules. The core will provide basic support for the prime areas of DDS use identified above and can be implemented on small as well as large computer systems. Each additional module will contain more advanced features that will result in a more powerful and complex DDS.

The FIPS DDS will specify:

- a "stand-alone" DDS, independent of specific hardware and software
- complete user interfaces to the DDS, including syntax and semantics for data description, input, output, and manipulation commands
- "extensibility"--the facility that will allow an agency to customize the structure of the contents of the DDS to accommodate its user needs

3. PROJECT FOCUS

The objective of the ICST project is to develop specifications that support Federal agency requirements, and that will be implemented by a wide spectrum of software suppliers (and thus be available "off-the-shelf"). To do this, the project is based on the following approach:

- close and continuing interaction with Federal users to determine which specific capabilities are required by a sufficiently large segment of the Federal community

- ⑥ detailed technological assessments and intensive consultation with hardware and software vendors, the research community, and Federal developers of in-house data dictionary systems, to determine
 - whether it is technologically practical to develop a particular capability in the near future, i.e., the next three to five years
 - if technologically feasible, whether it is economical for the software industry to produce such a capability in a competitive market
- ⑥ contractor support from the Alpha-Omega Group, Inc. in the development of the specifications
- ⑥ solicitation of comments and suggestions from all affected communities throughout the developmental process by issuing periodic reports and conducting workshops
- ⑥ continuing interchange with the American National Standards Institute (ANSI) Technical Committee X3H4 to ensure consistency with the planned national standard for a DDS, named the Information Resource Dictionary System (IRDS)
- ⑥ coordination with the Office of Management and Budget (OMB) to
 - review the prototype Federal Information Locator System (FILS) that OMB adopted in implementing the Paperwork Reduction Act of 1980 (P.L. 96-511)
 - ensure that the planned FIPS DDS is compatible with the FILS when it becomes fully operational
- ⑥ assistance to the Department of Defense Ada Joint Program Office by conducting an "Evaluation of the Applicability of the FIPS DDS to the Ada Environment"

4. PROJECT STATUS

The work plan for developing a FIPS DDS was divided into the following five phases:

- ④ state-of-the-art assessment of DDS technology
- ④ requirements definition
- ④ development of preliminary core DDS functional specifications
- ④ development of complete core FIPS DDS specifications
- ④ specification of optional FIPS DDS module(s) to provide additional capabilities

During the first phase, ICST analyzed relevant literature and existing commercial and Federally developed data dictionary systems. Features and capabilities in the current generation of DDSs were identified. A preliminary assessment identified projected technological trends and issues that warranted further investigation. ICST also sponsored the third Data Base Directions workshop, which focused on data dictionary systems. The following three products were published during the first phase:

- ④ Prospectus for Data Dictionary System Standard [1]. The Prospectus discusses the use of data dictionaries and describes ICST's plans to develop a Federal Information Processing Standard for Data Dictionary Systems. ICST encouraged technical input on the appropriate content for a FIPS DDS.
- ④ Guideline for Planning and Using a Data Dictionary System [2]. This publication discusses the capabilities and uses of data dictionary systems. It also provides Federal agencies with basic guidance on DDS selection, planning for the use of a DDS, DDS implementation, and operational usage of a DDS.
- ④ Data Base Directions: Information Resource Management--Strategies and Tools [3]. This report constitutes the results of the October, 1980 Data Base Directions workshop that investigated how managers can evaluate, select, and effectively use information resource management tools, especially data dictionary systems.

In the second phase of the project, ICST interviewed Federal agencies to identify current and projected requirements for data dictionary software. Interview results, as well as comments received on the Prospectus, were summarized in Federal Requirements for a Federal Information Processing Standard Data Dictionary System [4]. This report was distributed in the fall of 1981 to Federal agencies, to suppliers of data dictionary software, and to other individuals and organizations in the private sector working with data dictionaries.

Using the results of the first two phases, ICST worked closely with the ANSI X3H4 Technical Committee and with nationally recognized experts on data dictionary systems to develop the Functional Specifications for a Federal Information Processing Standard Data Dictionary System [5]. Three Federal agency and one DDS vendor workshops were held to review preliminary versions of the functional specifications, and the published document [5] contains modifications that the Federal representatives felt were needed to satisfy agency requirements. The document represents the results of the third phase of the work plan.

Work on the fourth phase started in October, 1982. Two products, which will constitute the FIPS DDS, are scheduled for development during this phase. These products are the DDS User's Manual, containing the specification of the user interfaces, and the DDS Implementors' Manual, containing guidance to be observed by the person or organization producing the DDS software. A Federal agency workshop to discuss the strategy for development of the DDS user's interface was held in February, 1983, and another, to review preliminary user interface specifications, is scheduled for June, 1983. A vendor workshop is planned for September, 1983. Current plans are to publish the complete FIPS DDS in fiscal year 1985. An interim report is scheduled to be published in fiscal year 1984 to obtain comments on the planned final draft of the FIPS DDS.

5. FUNCTIONAL SPECIFICATIONS FOR THE FIPS DDS

The DDS has three major components:

- the Dictionary -- the data contained within the DDS
- the Dictionary Schema -- a description of the generic structure of the dictionary
- the Dictionary Processing System -- the set of programs that interact with the dictionary and

dictionary schema to provide the functionality of the DDS

The functional specifications are based on an entity-relationship-attribute (E-R-A) structure. This paper uses the following definitions:

Entity -- any named concept, object, person, event, process, or quantity that is the subject of stored or collected data

Relationship -- a predetermined ordering between pairs of entities

Attribute -- a property or characteristic of an entity

5.1 The Dictionary

A DDS entity represents or names an object, person, etc., but it is not the actual data that exists in a file or data base. Thus, a DDS entity might be "social-security-number" or "payroll-record." It would not be the actual social security number "123-45-6789" or the actual content of a payroll record. Similarly, an attribute represents a characteristic of an entity. An example of an attribute of "social-security-number" is its length, e.g., "9 characters." An example of a relationship is "payroll-record contains social-security-number."

5.2 The Dictionary Schema

Attributes can be organized into sets called attribute-types, so that each member of a set represents a like characteristic. For example, "DATE CREATED" is a typical attribute-type.

Similarly, entities can be organized into entity-types. All instances of a specific entity-type have similar or identical characteristics or attribute-types. "Social-security-number" is an example of an "element" entity-type.

In the same manner, relationships can be grouped into relationship-types. All relationships, which are instances of a relationship-type, have attributes from the collection of attribute-types associated with that relationship-type. "System-contains-program" and "record-contains-element" are examples of relationships. (The concept of "type" is generally regarded as a collection of "instances.")

These "types" are the basic structures of the dictionary schema. The schema also contains structures used for the validation of attributes in the dictionary and for the support of the DDS status and staging facilities.

This entity-relationship-attribute construction used for the dictionary can be used to model the schema as well, thus providing an effective framework within which to construct, manipulate, and extend the schema. In other words, "entity-type," "relationship-type," and "attribute-type" can themselves be thought of as "entities" at a higher level of description. Thus, the DDS contains a "meta-schema," or schema describing the schema. ("Meta" is used in the sense of "data about data".) As an example of extensibility, a new entity-type to represent equipment can be created in the schema by adding the appropriately defined meta-entity "equipment." A meta-relationship between "user" and "equipment" could then define the relationship-type "user-uses-equipment," and a meta-relationship between "cost" and "equipment" would specify "cost" to be an attribute-type of "equipment."

5.3 The System Standard Schema

In order for the FIPS DDS to provide Federal agencies with the full benefits of inter- and intra-agency communication, the specifications include a specific collection of entity-types, relationship-types, and attribute-types. This collection, called the "system standard schema," is expected to be delivered as part of every software package conforming to the Federal Information Processing Standard. An agency can then augment this collection by using the extensibility feature.

Reflecting DDS usage in the Federal government, the system standard schema provides for eight data, process, and external entity-types:

Data Entity-Types

- ELEMENT, to describe instances of data belonging to an organization. Typical ELEMENTs are "social security number" and "agency name."
- DOCUMENT, to describe instances of human readable data collections. Typical DOCUMENTs are "Form 1040" and "FIPS Guideline."
- RECORD, to describe instances of logically associated data. Typical RECORDs are "employee record" and "payroll record."

- FILE, to describe instances of an organization's data collections. Typical FILES are "roster" and "accounts receivable."

Process Entity-Types

- SYSTEM, to describe instances of collections of processes and data. Typical SYSTEMS are "personnel system" and "airline reservation system."
- PROGRAM, to describe instances of automated processes. Typical PROGRAMS are "roster update" and "COBOL compiler."
- MODULE, to describe instances of automated processes that are either logical subdivisions of program entities or independent processes called by program entities. Typical MODULES are "sort records" and "main program."

External Entity-Types

- USER, to describe members belonging to an organization who use or are responsible for data in the data dictionary system. Typical USERS are "John Doe" and "personnel division."

Additionally, DICTIONARY-USER (to identify individuals and access privileges) and ACCESS-CONTROLLER entity-types are specified for the Dictionary Administrator to use in the management of the DDS's security system.

The relationship-types in the system standard schema include virtually all the connections between system standard entity-types that might prove useful to most agencies most of the time. The majority of these relationship-types are themselves grouped into classes. The six main classes are:

- CONTAINS, to describe instances of an entity being composed of other entities. A typical CONTAINS relationship-type is RECORD-CONTAINS-ELEMENT, which has as a possible instance the relationship "Payroll-record-contains-employee-name."
- PROCESSES, to describe associations between DATA and PROCESS entity-types. A typical PROCESSES relationship-type is SYSTEM-PROCESSES-FILE, which has as a possible instance the relationship "budget-system-processes-cost-center-file."

- ⑥ RESPONSIBLE-FOR, to describe associations between entities representing organizational components and other entities to denote organizational responsibility. A typical RESPONSIBLE-FOR relationship-type is USER-RESPONSIBLE-FOR-DOCUMENT, which has as a possible instance the relationship "personnel-office-responsible-for-SF-171."
- ⑥ RUNS, to describe associations between USER and PROCESS entity-types, illustrating that a person or organizational component is responsible for running a certain process. A typical RUNS relationship-type is USER-RUNS-PROGRAM, which has as a possible instance the relationship "John-Doe-runs-system-backup."
- ⑥ TO, which describes "flow" associations between PROCESS entity-types. A typical TO relationship-type is MODULE-TO-MODULE, which has as a possible instance the relationship "main-program-to-sort-routine," (indicating flow of control or data within a program).
- ⑥ DERIVED-FROM, describing associations between entities where the target entity is the result of a calculation involving the source entity. A typical DERIVED-FROM relationship-type is DOCUMENT-DERIVED-FROM-FILE, which has as a possible instance "annual-report-derived-from-plans-file."

The attribute-types developed for inclusion in the system standard schema are the ones that agencies generally want applied to system standard entity-types. Among the attribute-types in this collection are some that are common to all entity-types, including

- ⑥ attribute-types that provide audit trail information. A typical audit attribute-type is DATE-CREATED, which has as a possible instance "810101."
- ⑥ attribute-types that provide general documentation for entities, for example DESCRIPTION and CLASSIFICATION.

Other system standard attribute-types are associated with just one or a few entity-types. For example, ACCESS-METHOD, with possible attribute instance "indexed sequential," is unique to the FILE entity-type.

As an additional feature of the system standard schema, certain relationship-types have attribute-types associated with them. For example, the attribute-type REL-POSITION, associated with the RECORD-CONTAINS-ELEMENT relationship-type, can be used to document the relative position of an ELEMENT within a RECORD. Thus, "3" might be the REL-POSITION attribute that applies to the "employee-record-contains-social-security-number" relationship.

[5]. The system standard schema is completely described in

6. THE DDS USER INTERFACES

The FIPS core DDS will contain two user interfaces:

- The command language interface, designed to be used primarily by experienced users, will exercise the full functionality of the DDS and can be used in both batch and interactive modes. This interface will be a traditional language whose commands will have verbs, subjects, objects, clauses, etc.
- The screen-oriented interface, designed primarily for inexperienced users, will be used in an interactive mode. This interface will contain the subset of DDS functionality of greatest interest to most end-users. The FIPS will specify the collection of panels, or logical screens, comprising this interface.

Interface users will be able to interact with both the dictionary schema and the dictionary itself.

6.1 Interaction with the Dictionary Schema

These commands are designed primarily for the use of the dictionary administrator. Schema maintenance commands will add, modify, or delete entity-, relationship-, and attribute-types. Schema reporting commands will produce general listings and catalogs of the schema entries.

6.2 Interaction with the Dictionary

The facilities available for modifying and reporting on the dictionary content will be more elaborate than those for interacting with the schema. In particular, the dictionary administrator or dictionary user will be able to use fairly powerful search criteria to identify dictionary entities for later reporting or manipulation. This process, called

qualification, will result in a list of the names of the desired entities. The qualification list can then be used as input to other facilities.

The facilities for dictionary maintenance will allow users to add, modify, and delete entities, relationships, and attributes. The dictionary reporting facilities and the dictionary query facility will perform the central function of retrieving information from the dictionary. While the dictionary reporting capabilities will be able to generate short lists that may be returned on-line to a user terminal, their principal use is expected to be the generation of written reports. The simpler queries, used to generate simple outputs, will use the qualification facilities as basic building blocks, but also use special key words to simplify the user's task.

7. THE DDS SOFTWARE INTERFACES

The core FIPS DDS will include three interfaces with other software systems:

- the capability to produce, from the dictionary, representations of data usable within an ANSI COBOL program. In particular, this facility can produce a DATA DIVISION, including File and Working Storage sections.
- the ability to transfer a selected portion of the contents of one FIPS dictionary to another FIPS dictionary.
- the facility to provide access to a dictionary from a program written in any standard language that has a CALL statement.

8. DICTIONARY ADMINISTRATION

8.1 Security Facilities of the FIPS DDS

The DDS security feature consists of three levels of access control:

- The highest level controls access to both the Dictionary Processing System and to specified dictionaries. This level is provided by the implementor of the DDS software in a manner which is an option of the implementor.

- ⑥ The second level of control, the "global" level, occurs through dictionary entities of the type `DICTIONARY-USER` and their attributes. These entities specify the permissions that have been granted to a user in terms of the commands that the user can execute against specific entity-types. Likewise, privileges can be assigned to specified relationship-types. Attributes are also used to specify privileges of a dictionary user with respect to the schema.
- ⑦ The third level of control, the "local" level, occurs through dictionary entities of the type `ACCESS-CONTROLLER` and their attributes. Any entity can be protected by establishing a relationship in the dictionary between that specific entity and an entity of the type `ACCESS-CONTROLLER`.

8.2 Administrator Tools

The core FIPS will require tools to help establish, assure the integrity of, and monitor the performance of dictionaries. These tools will be specified as general implementor requirements because they are highly dependent on the particular system environment.

9. THE FINAL FIPS DDS SPECIFICATION

The FIPS Data Dictionary Specification will consist of two sets of documents.

9.1 The DDS User Documentation

The DDS User Documentation will be in two parts:

- ⑧ The User Manual will specify the functionality provided for interaction with the dictionary (except for security related commands).
- ⑨ The Dictionary Administrator Manual will specify the functionality provided for interaction with the dictionary schema, as well as for the security related commands.

These manuals will include the complete syntax and semantics of all commands, specifications for a "help" facility, possible error conditions, the resulting error messages, and the actions to be taken in case of error.

9.2 The DDS Implementor Documentation

The DDS Implementor Documentation will supplement the User Documentation for producers of DDS software. It will include, for example, a description of the panels required for the screen oriented-interface.

REFERENCES

- [1] Application Systems Division, Prospectus for Data Dictionary System Standard, NBSIR 80-2115, National Bureau of Standards, September, 1980.
- [2] National Bureau of Standards, Guideline for Planning and Using a Data Dictionary System, Federal Information Processing Publication 76, August, 1980.
- [3] Goldfine, Alan H., editor, Data Base Directions: Information Resource Management -- Strategies and Tools, NBS Special Publication 500-92, September, 1982.
- [4] Konig, Patricia A., and Newton, Judith J., Federal Requirements for a Federal Information Processing Standard Data Dictionary System, NBSIR 81-2354, National Bureau of Standards, September, 1981.
- [5] Konig, Patricia A., Goldfine, Alan, and Newton, Judith J., editors, Functional Specifications for a Federal Information Processing Standard Data Dictionary System, NBSIR 82-2619, National Bureau of Standards, January, 1983.

SPECIFICATIONS FOR A FEDERAL INFORMATION PROCESSING
STANDARD (FIPS) DATA DICTIONARY SYSTEM

INSTITUTE FOR COMPUTER SCIENCES AND TECHNOLOGY

NATIONAL BUREAU OF STANDARDS

WHAT IS IT?

- o A COMPUTER SOFTWARE SYSTEM
- o PROVIDES FACILITIES FOR RECORDING, STORING, AND PROCESSING INFORMATION ABOUT AN ORGANIZATION'S SIGNIFICANT DATA AND DATA PROCESSING RESOURCES

HOW IS IT BEING USED?

- o TO INVENTORY AN ORGANIZATION'S DATA RESOURCES
- o TO SUPPORT THE SYSTEM DEVELOPMENT LIFE CYCLE
- o TO INVENTORY COMPUTER EQUIPMENT AND SOFTWARE
- o TO SUPPORT DATA ELEMENT AND DOCUMENTATION STANDARDIZATION
- o AS A DIRECTORY TO LOCATE DATA IN CENTRALIZED OR DISTRIBUTED ENVIRONMENTS

Figure 11-1. Data Dictionary System (DDS).

- o PROVIDES STANDARD SPECIFICATIONS THAT CAN BE USED IN THE SELECTION, EVALUATION, AND PROCUREMENT OF DDS SOFTWARE
- o AIDS IN THE PORTABILITY OF SOFTWARE AND RELATED DATA
- o SUPPORTS PORTABILITY OF ACQUIRED SKILLS

Figure 11-2. Benefits of a FIPS for Data Dictionary Systems.

- o BE COMPRISED OF A CORE DDS TOGETHER WITH OPTIONAL MODULES
- o SPECIFY DATA DESCRIPTION, INPUT, OUTPUT, AND MANIPULATION COMMANDS AND FUNCTIONS, INCLUDING SYNTAX AND SEMANTICS
- o SPECIFY A "STAND-ALONE" DDS, INDEPENDENT OF SPECIFIC HARDWARE AND SOFTWARE
- o PROVIDE FOR FULL EXTENSIBILITY (CUSTOMIZATION OF THE STRUCTURE TO ACCOMMODATE USER NEEDS)

Figure 11-3. The FIPS Standard.

- o COORDINATION WITH FEDERAL AGENCIES
 - DIRECT, ON-GOING INTERACTION WITH AGENCIES
 - FEDERAL AGENCY WORKSHOPS
 - DIRECT ASSISTANCE TO OTHER AGENCIES
- o CONTRACTOR SUPPORT IN DEVELOPMENT OF SPECIFICATIONS
- o ACTIVE PARTICIPATION ON ANSI X3H4 TECHNICAL COMMITTEE
- o INTERACTION WITH DDS VENDORS
 - VENDOR WORKSHOPS
 - IN-DEPTH TECHNICAL DISCUSSIONS WITH MAJOR DDS VENDORS
- o USER GROUPS -- SPEECHES AND PANELS
- o PRESENTATIONS TO FADPUG SPECIAL INTEREST GROUPS
- o ASSISTANCE TO DOD AdaTM PROJECT

Figure 11-4. DDS Project Focus.

FIVE STAGES -- BEGAN IN 1979

1. ASSESSMENT OF STATE-OF-THE-ART DDS TECHNOLOGY -- COMPLETED
 - o PROSPECTUS FOR DATA DICTIONARY SYSTEM STANDARD,
NBSIR 80-2115 8/80
 - o GUIDELINE FOR PLANNING AND USING A DATA DICTIONARY SYSTEM,
FIPS PUBLICATION 76 3/80

 2. REQUIREMENTS DEFINITION -- COMPLETED
 - o FEDERAL REQUIREMENTS FOR A FEDERAL INFORMATION PROCESSING
STANDARD DATA DICTIONARY SYSTEM,
NBSIR 81-2355 9/81
(AUERBACH REPRINTED AS TWO PORTFOLIOS)
- Figure 11-5. Project Approach.
3. DEVELOPMENT OF DDS FUNCTIONAL SPECIFICATION -- COMPLETED
 - o FUNCTIONAL SPECIFICATIONS FOR A FEDERAL INFORMATION PROCESSING
STANDARD DATA DICTIONARY SYSTEM
NBSIR 82-2619 1/83
 - DEFINES SYSTEM FUNCTIONS AND CAPABILITIES
 - DOES NOT SPECIFY USER INTERFACE (SYNTAX AND SEMANTICS,
"HELP" FACILITIES)

 4. FINALIZE SPECIFICATIONS FOR CORE FIPS DDS -- IN PROGRESS

 5. DEVELOP OPTIONAL MODULES

Figure 11-5. Project Approach (Continued).

FY 84: PUBLISH FIPS DDS SPECIFICATIONS

FY 85: ISSUE DDS FEDERAL INFORMATION PROCESSING STANDARD

FY 86-87: PUBLISH GUIDELINES ON DDS USE
PUBLISH OPTIONAL MODULE(S) SPECIFICATIONS

Figure 11-6. Current Schedule.

- o DICTIONARY SCHEMA (STRUCTURE)
- o DICTIONARY (CONTENTS)
- o DICTIONARY PROCESSING SYSTEM

Figure 11-7. Components of a DDS.

- o ENTITIES
- o RELATIONSHIPS
- o ATTRIBUTES OF ENTITIES AND RELATIONSHIPS

Figure 11-8. Specification Uses E-R-A Model.

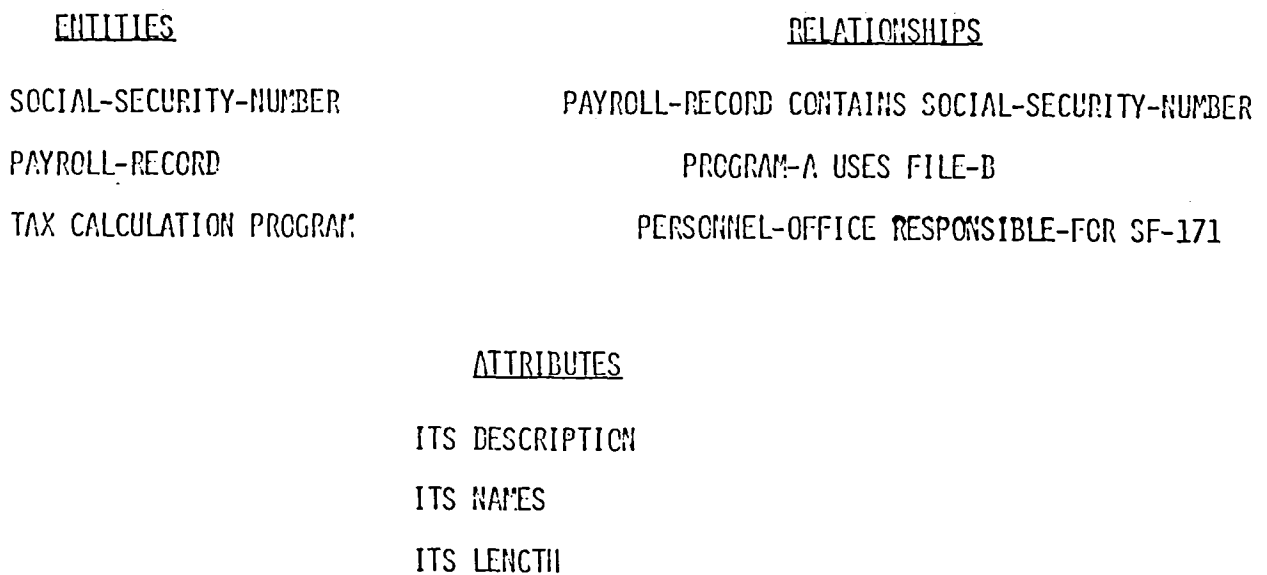

Figure 11-9.

ENTITY-TYPES

FILE
SYSTEM
PROGRAM
DOCUMENT
ELEMENT

RELATIONSHIP-TYPES

PROGRAM-USES-FILE
SYSTEM-CONTAINS-PROGRAM
DOCUMENT-PROCESSED-BY-MODULE

ATTRIBUTE-TYPES

DESCRIPTION (OF A FILE)
SIZE (OF A DOCUMENT)
ACCESS-METHOD (FOR PROGRAM-USES-FILE)

Figure 11-10.

- o META- ENTITY-TYPES
 - ENTITY-TYPE
 - RELATIONSHIP-TYPE
 - ATTRIBUTE- TYPE
 -
- o META-RELATIONSHIP-TYPES
 - [RELATIONSHIP-TYPE, ENTITY-TYPE]
 - [ENTITY-TYPE, ATTRIBUTE-TYPE]
 -
- o META-ATTRIBUTE-TYPES
 - AUDIT OF THE SCHEMA
 - STRUCTURE
 - INTEGRITY OF THE DICTIONARY
 -

Figure 11-11. Meta-Schema.

ENTITY-TYPES

- o SYSTEM
- o PROGRAM
- o MODULE
- o FILE
- o DOCUMENT
- o RECORD
- o ELEMENT
- o USER

RELATIONSHIP-TYPE CLASSES

- o CONTAINS
- o PROCESSES
- o RESPONSIBLE FOR
- o RUNS
- o TO
- o DERIVED FROM

ATTRIBUTE-TYPE CLASSES

- o AUDIT
- o DESCRIPTION
- o OTHER NAMES
- o OTHERS

Figure 11-12. The System Standard Schema.

- o COMMAND LANGUAGE INTERFACE
 - DESIGNED FOR EXPERIENCED USERS
 - CAN BE USED IN BOTH BATCH AND INTERACTIVE MODES
 - CAN USE FULL FUNCTIONALITY OF THE DDS
- o SCREEN ORIENTED INTERFACE
 - DESIGNED FOR INEXPERIENCED USERS
 - INTERACTIVE MODE
 - USES LARGE SUBSET OF DDS FUNCTIONALITY

Figure 11-13. DDS User Interfaces.

- o INTERACTION WITH THE SCHEMA
 - MAINTENANCE
 - REPORTING

- o INTERACTION WITH THE DICTIONARY
 - QUALIFICATION
 - MAINTENANCE
 - REPORTING
 - QUERYING

Figure 11-14. User Interfaces to Accomplish.

- o GENERATE STRUCTURE FOR COBOL

- o EXPORT/IMPORT

- o CALL FACILITY

Figure 11-15. Interfaces with External Software.

- o SECURITY FACILITY
- o DICTIONARY ESTABLISHMENT
- o DICTIONARY INTEGRITY
- o DICTIONARY PERFORMANCE

Figure 11-16. Dictionary Administration.

- o DDS USER DOCUMENTATION
 - USER MANUAL
 - DICTIONARY ADMINISTRATOR MANUAL
- o DDS IMPLEMENTOR DOCUMENTATION
 - EXPANDED VERSION OF FUNCTIONAL SPECIFICATIONS
 - PANEL SPECIFICATIONS

Figure 11-17. The Final FIPS DDS Specification.

INSTITUTE FOR COMPUTER SCIENCES AND TECHNOLOGY
NATIONAL BUREAU OF STANDARDS
TECHNOLOGY BLDG., ROOM A-265
WASHINGTON, DC 20234

PATRICIA KONIG
ALAN GOLDFINE
(301) 921-3491

Figure 11-18. FIPS Data Dictionary Program.

12. NASA-WIDE STANDARD ADMINISTRATIVE SYSTEMS

Paul Schneck
Goddard Space Flight Center

PRODUCTIVITY & ADMINISTRATIVE COMPUTING

Figure 12-1

<u>(HALF FULL)</u>	<u>(HALF EMPTY)</u>
INDEPENDENT CENTER APPROACHES	POOR COORDINATION, DUPLICATION
CENTER-OPTIMAL SOLUTIONS	LACK OF INTER-OPERABILITY; NOT AGENCY-OPTIMAL
HIGHLY RESPONSIVE	DIFFICULT TO OBTAIN COMPARABLE DATA
FINELY TUNED, WELL RUNNING SYSTEM	WITH 150K MILES, AND 11 MPG (OLD SOFTWARE, PATCHED, DIFFICULT TO MAINTAIN)
AUTOMATING ADDITIONAL FUNCTIONS	NOT STRATEGICALLY PLANNED TO MAXIMIZE RETURN-ON-INVESTMENT

Figure 12-2. Where Are We Now?

<u>TARGET</u>	<u>IMPOSED REQUIREMENT</u>
COMMON TECHNICAL APPROACH	COMMUNICATION, COORDINATION
AGENCY-OPTIMAL	MANAGE TO AGENCY GOALS GENERATE CENTER INCENTIVES
REMAIN RESPONSIVE	CORE CAPABILITY AT EACH CENTER, UNIQUE SUPPORT
"MODERN" SYSTEM APPROACH	SOME NEW HARDWARE; NEW SOFTWARE NEW "PHILOSOPHY" — INTERACTIVE; DATA BASE
ADMINISTRATIVE OPERATIONS REDESIGNED RECOGNIZING CURRENT LABOR/ADP COST RELATIONSHIP	CLEAN HOUSE, DISCARD UNNECESSARY CONSTRAINTS, EVOLVE NEW SYSTEMS

Figure 12-3. Where Could We Be?

COMPUTING IS A POSITIVE-SUM GAME

Figure 12-4

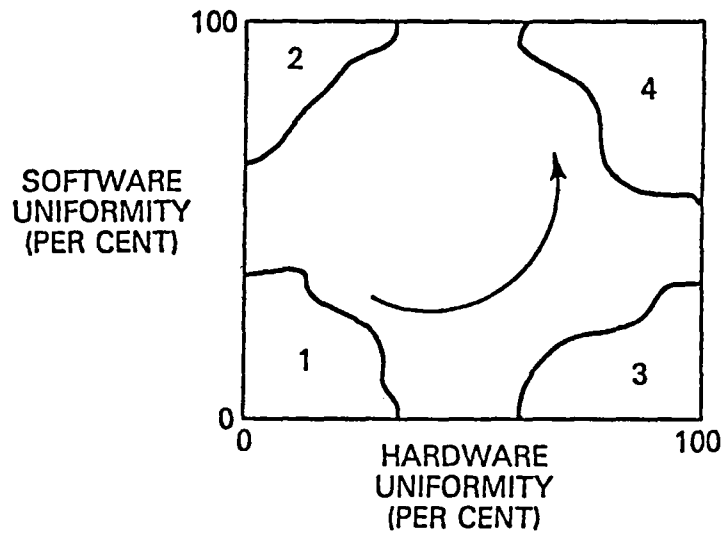

<u>REGION</u>	<u>MEANING</u>
1	SMALL DEGREE OF UNIFORMITY IN HARDWARE AND IN SOFTWARE
2	UNIFORM SOFTWARE ON DISPARATE HARDWARE SYSTEMS — HARD TO MANAGE!
3	UNIFORM HARDWARE WITH INDIVIDUAL SOFTWARE — SMALL SAVINGS IN ADP OPERATIONS
4	UNIFORM HARDWARE AND SOFTWARE

Figure 12-5. A Perspective.

N.B. "UNIFORM" DOES NOT MEAN "STANDARD"

USER CONCERN: "THEY" WILL DEFINE STANDARD SYSTEMS

Figure 12-6

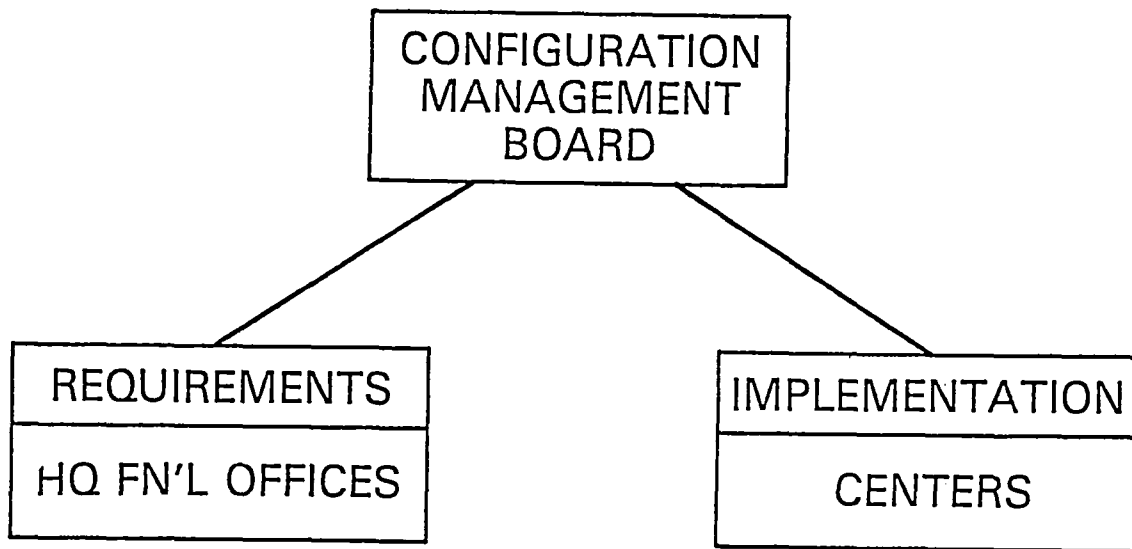

Figure 12-7. Process.

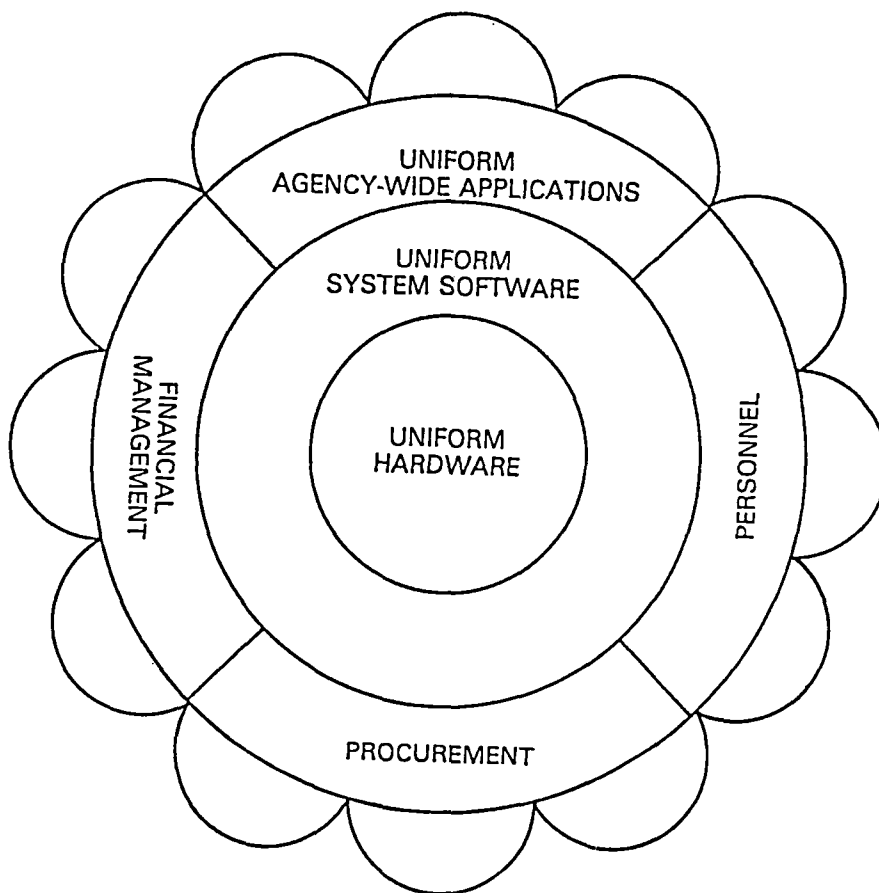

Figure 12-8

- HARDWARE AND SOFTWARE DISCOUNTS
 - INCREASED VENDOR RESPONSIVENESS
 - INSTALLATION BACKUP
 - EQUIPMENT SHARING
 - INCREASED COMMUNICATION
 - SOFTWARE SHARING
 - INCREASED DEPTH OF EXPERTISE
 - SENSITIVITY TO AGENCY COST/BENEFIT
 - COORDINATED SOFTWARE DEVELOPMENT
 - REDUCED DUPLICATION
- * ATTAINABLE THROUGH EVOLUTION
 - * CAN BOOTSTRAP IMPLEMENTATION THROUGH COST SAVINGS
 - * FACILITATE ADMINISTRATIVE SYSTEM MODERNIZATION

Figure 12-9. Payoff of Uniform Hardware/Software Systems.

CURRENTLY:

REQUIREMENTS DEFINITION IS CENTRALIZED

IMPLEMENTATIONS ARE DISPERSED

OPERATIONS ARE DECENTRALIZED

PROPOSED:

REQUIREMENTS PROPOSALS REMAIN CENTRALIZED

REQUIREMENTS DEFINITION COORDINATED WITH CENTERS

IMPLEMENTATIONS DECENTRALIZED, BUT LOCALIZED

OPERATIONS REMAIN DECENTRALIZED

Figure 12-10. Centralization/Decentralization.

SEPARATE IMPLEMENTATIONS	ONE IMPLEMENTATION
LOCAL FAILURE	GLOBAL (LATENT) FAILURE
LOCAL KNOWLEDGE	IN-DEPTH EXPERTISE
LOCAL OPTIMIZATION (INCONSISTENT?)	UNIFORM TREATMENT
NOT EXPOSED TO FAILURES DUE TO OTHER CENTERS' COMPLICATIONS (EACH CENTER'S FAILURES ARE UNIQUE)	RAPID PROGRESS UP THE LEARNING CURVE — LARGER TEST SPACE — ACHIEVE ROBUSTNESS SOONER
	FOLLOWS INDUSTRIAL PRACTICE

Figure 12-11. Risk Exposure.

- SURVEY FIELD
- DEFINE REQUIREMENTS
- SELECT IMPLEMENTATION TEAM (IN/OUT, WHERE, WHO)
- INTERNAL TESTS (" α ")
- EXTERNAL TEST SITES (" β ")
- INCORPORATE MODIFICATIONS
- RELEASE TO FIELD
- MAINTENANCE CYCLE — REMAINS WITH IMPLEMENTATION TEAM

Figure 12-12. Industrial Model for Software Development.

13, DBMS AS A TOOL FOR PROJECT MANAGEMENT

Henry Linder
Goddard Space Flight Center

- INTRODUCTION TO CRUSTAL DYNAMICS PROJECT
- CRUSTAL DYNAMICS DATA INFORMATION SYSTEM
- EXAMPLES OF USING A DBMS AS A PROJECT MANAGEMENT TOOL
- CONCLUSIONS

Figure 13-1. DBMS As a Project Management Tool.

THE SCIENTIFIC OBJECTIVES OF THE CRUSTAL DYNAMICS PROJECT ARE TO IMPROVE OUR KNOWLEDGE AND UNDERSTANDING OF:

- REGIONAL DEFORMATION AND STRAIN ACCUMULATION RELATED TO EARTHQUAKES AT THE PLATE BOUNDARY IN THE WESTERN UNITED STATES
- CONTEMPORARY RELATIVE PLATE TECTONIC MOTIONS OF THE NORTH AMERICAN, PACIFIC, SOUTH AMERICAN, EURASIAN, AUSTRALIAN, NAZCA, AND CARIBBEAN PLATES
- INTERNAL DEFORMATION OF LITHOSPHERIC PLATES AWAY FROM PLATE BOUNDARIES, WITH PARTICULAR EMPHASIS ON NORTH AMERICA
- POLAR MOTION AND VARIATIONS IN EARTH ROTATION AND THEIR POSSIBLE CORRELATION WITH EARTHQUAKES, PLATE MOTIONS, AND OTHER GEOPHYSICAL PHENOMENA
- CRUSTAL MOTION AND DEFORMATION OCCURRING IN OTHER REGIONS OF HIGH EARTHQUAKE ACTIVITY

Figure 13-2. Scientific Objectives of Crustal Dynamics.

- IMPLEMENTATION OF A CENTRALIZED DATA INFORMATION SYSTEM (DIS) FOR THE CRUSTAL DYNAMICS PROJECT
- SYSTEM BECAME FULLY OPERATIONAL IN SEPTEMBER 1982
- THE DATA BASE OF THE CRUSTAL DYNAMICS PROJECT CONTAINS:
 - CATALOG OF ALL ACQUIRED AND AVAILABLE DATA
 - ARCHIVES OF PROCESSED LASER AND VLBI DATA
 - ARCHIVES OF ANALYZED LASER AND VLBI DATA WITH COMMENTS AND ANNOTATIONS (BASELINES, POLAR MOTION AND UT1, ETC.)
 - ANCILLARY DATA (E.G., SITE SURVEYS, STATION COORDINATES, ETC.)
 - TEST DATA INCLUDING USER COMMENTS ABOUT DATA, REFERENCES TO DETAILED DESCRIPTIONS OR ANALYSES, ETC.
 - NEWSLETTER AND MESSAGE EXCHANGES (E.G., NOTEWORTHY COMMENTS FOR GENERAL DISSEMINATION)
 - LASER OR VLBI DATA REQUESTS
 - PROJECT MANAGEMENT DATA



5/26/83

Figure 13-3. Crustal Dynamics Data Information System.

- EASY PREPARATION OF SCHEDULES AND THEIR TIMELY DISTRIBUTION
- GOOD VISIBILITY IS IMPORTANT TO PROJECT MANAGEMENT, ENGINEERING AND OPERATIONS, SCIENTIFIC INVESTIGATORS AND DATA RECIPIENTS
- SEVERAL ITERATIONS OF SCHEDULE CHANGES CAN BE ACCOMMODATED
- MANAGEMENT REPORTS OF ACTUAL OBSERVATION DATA YIELD CAN BE PREPARED



5/26/83

Figure 13-4. Project Observation Schedules.

- HISTORICAL STATUS OF SYSTEM CONFIGURATIONS
- ALLOWS ASSESSMENT OF MEASUREMENT CHAIN AND THE EVALUATION OF SYSTEM ERRORS AND ACCURACY
- TRACKING OF CONFIGURATION CHANGE REQUESTS
- MANAGEMENT REPORTS FOR TRACKING OUTSTANDING REQUESTS OR FOR SPECIFIC ITEMS



5/26/83

Figure 13-5. Project Configuration Control Information.

- VERY LENGTHY AND DETAILED INFORMATION
- DATA BASE IMPOSES MORE DISCIPLINE ON THE FORMATTING AND PRESENTATION OF THE INFORMATION
- REPORTS CAN BE PREPARED MORE RAPIDLY
- VARIOUS TYPES OF INFORMATION CAN BE REPORTED AS NEEDED BY MANAGEMENT
- ACCESS AND VISIBILITY OF ANY INFORMATION TO REMOTE USERS IS FEASIBLE



5/26/83

Figure 13-6. Project Site Information.

- DATA BASE TECHNOLOGY PROVIDES A SIGNIFICANT INFORMATION TOOL FOR PROJECT MANAGEMENT
- INFORMATION DATA IS A VALUABLE RESOURCE FOR ANY PROJECT
- PROPER ADMINISTRATION OF INFORMATION DATA IS ESSENTIAL



5/26/83

Figure 13-7. Conclusions.

14. USE OF DBMS IN MULTI-STEP INFORMATION SYSTEMS FOR LANDSAT

Carey E. Noll
Goddard Space Flight Center

- o LANDSAT-4 WAS LAUNCHED IN JULY, 1982
- o SENSORS: MULTISPECTRAL SCANNER, THEMATIC MAPPER
- o THEMATIC MAPPER OBTAINS DATA IN SEVEN BANDS
- o DATA TELEMETERED AND ELECTRONICALLY RECORDED AT GROUND STATION
- o THEMATIC MAPPER DATA MUST BE GEOMETRICALLY AND RADIOMETRICALLY CORRECTED BEFORE PRODUCING A PHOTOGRAPHIC IMAGE

Figure 14-1. Multi-Step Information System.

PRODUCTION SYSTEM CHARACTERISTICS

Figure 14-2

- o SEVERAL SCENES SELECTED PER WEEK FOR PROCESSING
- o EACH SCENE REQUIRES AN AVERAGE OF UP TO TWO MONTHS OF PROCESSING
- o A SCENE MAY BE REJECTED AT ANY PRODUCTION STAGE
- o UP TO THREE DIFFERENT WORK ORDER NUMBERS MAY BE ASSOCIATED WITH ONE SCENE

Figure 14-3

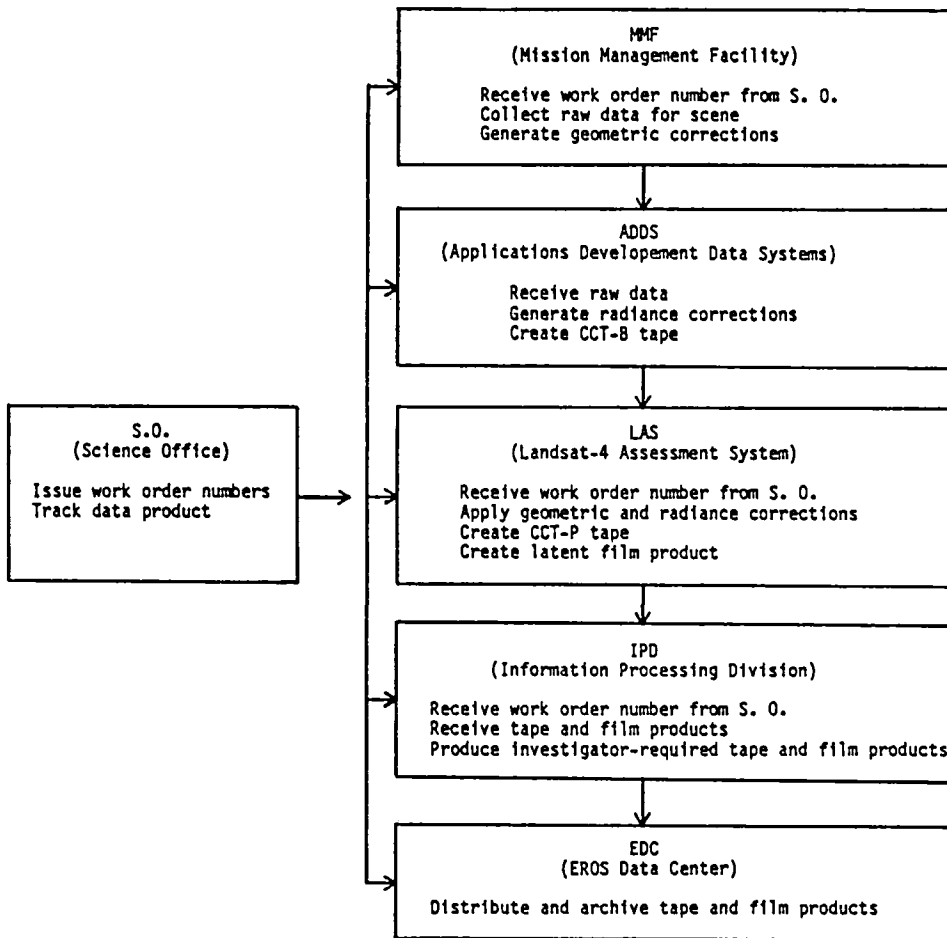

Figure 14-4. LANDSAT-4 Thematic Mapper Data Products Processing Diagram.

REQUIREMENTS:

- o INCORPORATION OF NEWLY SELECTED SCENES

- o ACCESS OF STATUS INFORMATION PERTAINING TO ANY ONE SCENE
AT A GIVEN TIME

- o WEEKLY REPORTS SUMMARIZING ALL PRODUCTS

- o UPDATE OF ANY SCENE ENTRY AS INFORMATION BECOMES AVAILABLE

Figure 14-5

CURRENT SYSTEM CHARACTERISTICS

Figure 14-6

- o MENU-DRIVEN ACCESS TO PRODUCT INFORMATION
- o COMPUTER KNOWLEDGE NOT REQUIRED
- o SYSTEM CAN BE ACCESSED FROM REMOTE WORK STATIONS
- o UNDERLYING STRUCTURE PROVIDED BY A RELATIONAL DBMS (ORACLE)

Figure 14-7

- o EMPLOYS A TABULAR FORMAT STRUCTURE
- o ALLOWS FLEXIBILITY WHEN CREATING TABLES
- o ORDER OF INSERTED DATA ITEMS NOT IMPORTANT
- o ALLOWS UPDATES TO ANY DATA RECORD AS INFORMATION BECOMES AVAILABLE
- o FACILITATES DATA ENTRY AND UPDATE PROCEDURES THROUGH FORMATTED SCREEN DISPLAYS
- o FACILITATES THE GENERATION OF SORTED REPORTS, EXTRACTING ALL OR A SUBSET OF THE ENTIRE TABLE
- o SECURES DATA TO AUTHORIZED USERS

Figure 14-8

SITE_NAME	PATH_ROW	ACQ_DATE	SCENE_ID	PPF_MON	PPF_DATE	PPF_COM	ADDS_COM	LAS_MON	LAS_DATE	LAS_TCOM	LAS_TREL
CHAR(10) INDEXED	CHAR(9) INDEXED	NUMBER INDEXED	CHAR(10) INDEXED	CHAR(5) INDEXED	NUMBER	NUMBER	NUMBER	CHAR(5) INDEXED	NUMBER	NUMBER	NUMBER

LAS_FREQ	LAS_FCOM	LAS_FSO	IPD_MON	IPD_DATE	IPD_COM	IPD_SHP	EDC_TAPE	EDC_FILM	CO	COMMENTS
NUMBER	NUMBER	NUMBER	CHAR(5) INDEXED	NUMBER	NUMBER	NUMBER	NUMBER	NUMBER	CHAR(2) INDEXED	CHAR(60)

Figure 14-9. Structure of Table Containing Data Products Information.

- 1 -- Various ORACLE Screen Displays
- 2 -- ORACLE Data Base Management System
- 3 -- Exit from LANDSAT-4 Management Information System

Please enter your selection:

Figure 14-10. LANDSAT-4 Science Data Products Information System.

MENU

- 1 -- Personnel Information Screen Form
- 2 -- Financial Information Screen Form
- 3 -- Investigator Test Site Information Screen Form
- 4 -- Investigator Data Product Requirements Screen Form
- 5 -- Data Products Status Information
- 6 -- Exit from Screen Displays Menu

Please enter your screen display selection:

Figure 14-11. Screen Displays MENU.

```

SCIENCE OFFICE INFORMATION:
  Scene Information:      Site Name: WASH DC
                        Path/Row Location: P015 R033
                        Acquisition Date: 11/02/82
                        Scene ID: 4010915140
  Work Order Information: MMF: 01621
                        Dated: 11/02/82
                        LAS: 01621
                        Dated: 11/02/82
                        IPD: T0082
                        Dated: 11/09/82
                        Status:      Code: C
  MMF INFORMATION:
    Dates:      Completed: 11/03/82
  ADDS INFORMATION:
    Dates:      Completed: 11/04/82
  LAS INFORMATION:
    Tape Dates: Completed: 11/05/82
                Released: 11/09/82
    Film Dates: Requested: 11/05/82
                Completed: 11/09/82
                Science Office: 11/29/82
  IPD INFORMATION:
    Dates:      Completed: 11/12/82
                Shipped: 11/15/82
  EDC CONFIRMATION:
    Dates:      Tape: 11/19/82
                Film: 12/14/82
  Comments: NONE

```

Figure 14-12. LANDSAT-4 Science Office Data Products Information System Data Products Tracking Information.

- 1 -- Report Listing All Entered Data Products
- 2 -- Report Listing All Active Data Products
- 3 -- Report Listing All Active Data Products per Production Unit
- 4 -- Report Listing All Completed Data Products
- 5 -- Report Listing All Inactive Data Products
- 6 -- Report Listing All Cancelled Data Products
- 7 -- Weekly Summary Report
- 8 -- Exit from Data Products Reports Menu

Please enter your report selection:

Figure 14-13. Data Products Reports MENU.

SCENE INFORMATION				MMF	ADDS	LAS			IPD	EDC				
Site Name	Path/Row	Acq. Date	Scene ID	W.O. Num.	Dated/Complete	ADDS Complete	W.O. Num.	Dated	Complete/Released	Request/Complete/Sci.Off.	W.O. Num.	Dated/Complete/Shipped	Tape/Film	CD
HRRSBRG PA	P015 R032	11/02/82	4010915134	01713	11/08/82 11/11/82	11/22/82	02001	11/29/82	11/30/82 01/14/83	12/03/82 01/13/83 01/14/83	T0190	01/17/83 01/25/83 01/27/83	01/31/83 12/20/82	C
HRRSBRG PA	P015 R032	01/21/83	4018915151	03612	03/21/83 03/25/83	04/07/83	03904	04/11/83	04/16/83 04/28/83	04/11/83 04/26/83 04/28/83	T0380	04/29/83 05/04/83 05/06/83	05/03/83	A*
WASH DC	P015 R033	07/29/82	4001315125	00301	07/30/82 07/31/82	08/02/82	00301	08/03/82	08/03/82 03/23/83	09/01/82 09/02/82 09/02/82	T0339	04/06/83 04/12/83 04/14/83	04/20/83 11/05/82	C
WASH DC	P015 R033	10/17/82	4009315140	01611	11/01/82 11/02/82									XM
WASH DC	P015 R033	11/02/82	4010915140	01621	11/02/82 11/03/82	11/04/82	01621	11/02/82	11/05/82 11/09/82	11/05/82 11/09/82 11/29/82	T0082	11/09/82 11/12/82 11/15/82	11/19/82 12/14/82	C
WASH DC	P015 R033	11/18/82	4012515144	02811	01/24/83 01/30/83	03/04/83								XA
ROHMND VA	P015 R034	10/17/82	4009315142	01618	11/01/82 11/02/82									XM
WILMINTH NC	P015 R036	10/17/82	4009315151	01620	11/01/82 11/02/82									XM
WILMINTH NC	P015 R036	12/20/82	4015715154	02518	01/03/83 01/07/83	01/14/83	02806	01/24/83	01/27/83 02/09/83	01/24/83 02/08/83 02/10/83	T0240	02/14/83 02/17/83 02/19/83	02/24/83 02/11/83	C
SC OCEAN	P015 R038	08/30/82	4004515151	00801	09/07/82 09/13/82	09/14/82	00801	09/14/82	09/14/82 10/05/82	09/14/82 10/12/82 10/12/82	T0039	10/18/82 03/01/83 03/03/83	03/08/83 11/08/82	C
GULF STRM	P015 R040	12/20/82	4015715172	02517	01/03/83 01/07/83	01/15/83	02804	01/24/83	01/26/83 02/16/83	01/24/83 02/16/83 02/18/83	T0248	02/21/83 02/25/83 02/27/83	03/04/83 02/11/83	C

Figure 14-14

Description		Total	Good	Cancelled
Number of MMF Scenes:	Requested:	386	---	---
	Completed:	379	343	36
Number of ADDS Scenes:	Completed:	318	306	12
Number of LAS Scenes:	Requested:	252	---	---
	Completed:	231	195	36
Number of IPD to EDC Scenes:	Requested:	195	---	---
	Completed:	190	---	---
Number of EDC Scenes:	Completed:	180	---	---

Figure 14-15. Scrounge Data Production as of 05/10/83
Totals.

CONCLUSIONS:

- o TRACKING SYSTEM PROVIDES UP-TO-DATE AND COMPLETE INFORMATION
- o CURRENT SYSTEM REQUIRES PRODUCTION STAGES ADHERE TO THE INHERENT DBMS STRUCTURE
- o CONCEPT CAN BE APPLIED TO ANY PROCEDURES REQUIRING STATUS INFORMATION

Figure 14-16

1. Report No. NASA CP-2304		2. Government Accession No.		3. Recipient's Catalog No.	
4. Title and Subtitle NASA ADMINISTRATIVE DATA BASE MANAGEMENT SYSTEMS - 1983				5. Report Date April 1984	
				6. Performing Organization Code NTD	
7. Author(s) James D. Radosevich, Editor				8. Performing Organization Report No. 2	
				10. Work Unit No.	
9. Performing Organization Name and Address NASA Headquarters ADP Management Branch Washington, DC 20546				11. Contract or Grant No. None	
				13. Type of Report and Period Covered Conference Publication	
12. Sponsoring Agency Name and Address National Aeronautics and Space Administration Washington, DC 20546				14. Sponsoring Agency Code NT	
15. Supplementary Notes None					
16. Abstract The papers contained in this proceedings were presented during the second annual NASA Administrative Data Base Management Conference. The fifteen papers address technical and management problems associated with evaluation, selection, installation and use of DBMS packages in the NASA administrative support environment. The presentation material and papers are organized in this proceedings in the sequence of their presentation, and are printed in the form provided by the authors.					
17. Key Words (Suggested by Author(s)) Administrative DBMS Data Base Management Systems DBMS evaluation, DBMS selection, DBMS installation, DBMS usage			18. Distribution Statement Unclassified - Unlimited Subject Category 82		
19. Security Classif. (of this report) Unclassified		20. Security Classif. (of this page) Unclassified		21. No. of Pages 150	22. Price A07

National Aeronautics and
Space Administration

Washington, D.C.
20546

Official Business

Penalty for Private Use, \$300

SPECIAL FOURTH CLASS MAIL
BOOK

Postage and Fees Paid
National Aeronautics and
Space Administration
NASA-451



NASA

POSTMASTER: If Undeliverable (Section 158
Postal Manual) Do Not Return
