

NASA TM-83736

NASA Technical Memorandum 83736

NASA-TM-83736 19840021809

# Fuel Savings Potential of the NASA Advanced Turboprop Program

J. B. Whitlow, Jr. and G. K. Sievers  
National Aeronautics and Space Administration  
*Lewis Research Center*  
*Cleveland, Ohio 44135*

LIBRARY COPY

FEB 14 1985

LANGLEY RESEARCH CENTER  
LIBRARY, NASA  
HAMPTON, VIRGINIA

Prepared for the  
Aviation Fuel Conservation Symposium  
sponsored by the Federal Aviation Administration  
Washington, D.C., September 10-11, 1984

**NASA**

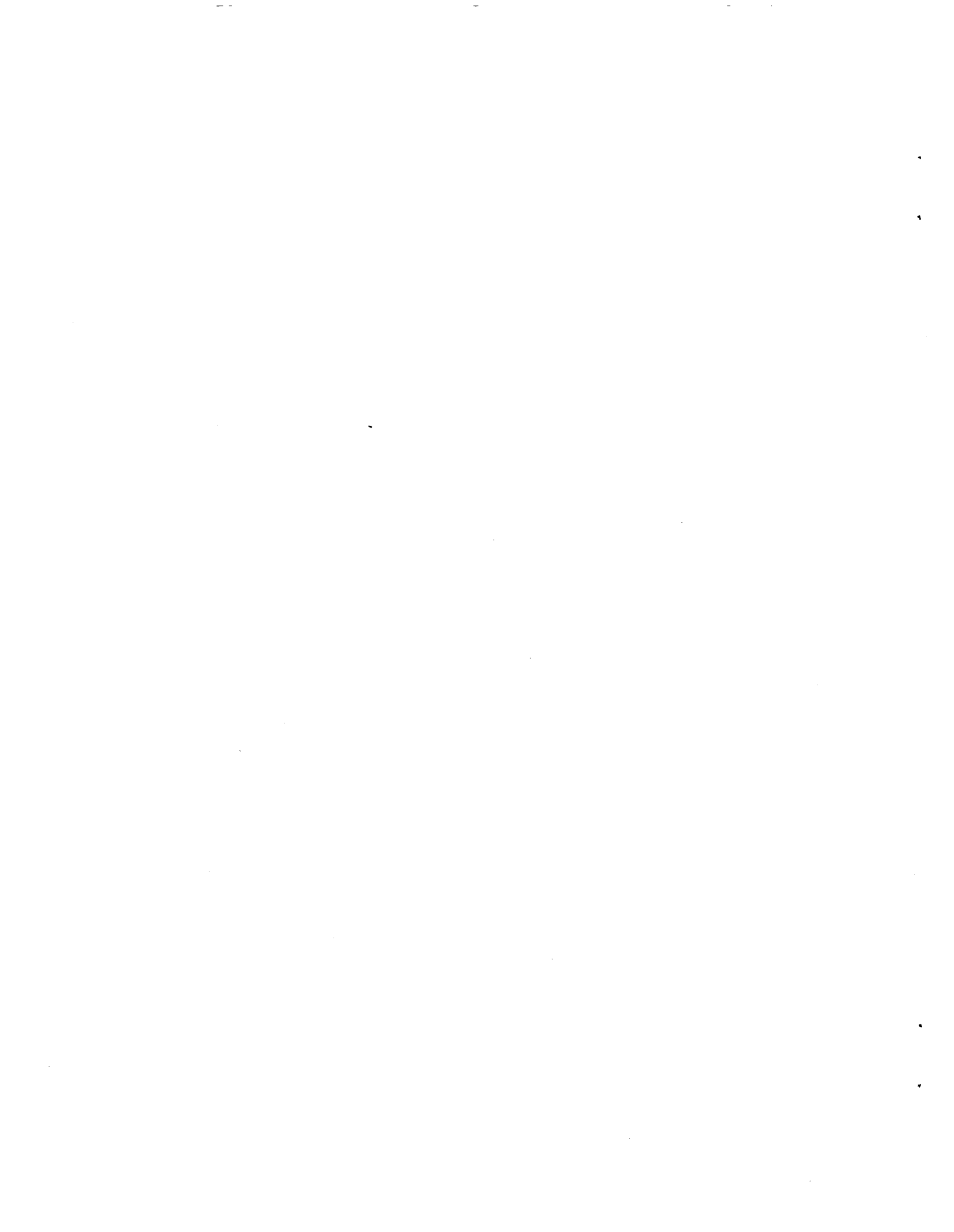

FUEL SAVINGS POTENTIAL OF THE NASA ADVANCED TURBOPROP PROGRAM

J. B. Whitlow, Jr. and G. K. Sievers  
National Aeronautics and Space Administration  
Lewis Research Center  
Cleveland, Ohio 44135

N84-29878 #

FUEL SAVINGS POTENTIAL OF THE NASA ADVANCED TURBOPROP PROGRAM

J. B. Whitlow, Jr. and G. K. Sievers  
National Aeronautics and Space Administration  
Lewis Research Center  
Cleveland, Ohio 44135

SUMMARY

The NASA Advanced Turboprop (ATP) Program is directed at developing new technology for highly-loaded, multi-bladed propellers for use at Mach 0.65 to 0.85 and at altitudes compatible with the air transport system requirements. Advanced turboprop engines offer the potential of 15 to 30 percent savings in aircraft block fuel relative to advanced turbofan engines (50 to 60 percent savings over today's turbofan fleet). The program to develop the technologies needed to implement this potential fuel savings and an accompanying 7 to 15 percent operating cost advantage consists of both a small-scale model and analytical technology effort as well as a test program to evaluate large-scale hardware. Both single-rotation and counter-rotation turboprop systems are included. In the counter-rotation area, both geared systems and a unique gearless pusher configuration are being pursued. The analytical and subscale model experimental effort includes investigations in the areas of propeller aeroperformance, aeroelasticity, and acoustics; installation aerodynamics; cabin environment; and systems integration and benefit assessment. Advanced gearbox technology will also be investigated through a program consisting of design studies and component testing. A major focus of the ATP Program is the



design, fabrication, and test of an eight-bladed nine-foot diameter single-rotation propfan for a series of tests to evaluate the structural, aeroelastic, and acoustic characteristics of large-scale thin, swept blades. These characteristics cannot be reliably scaled at the present time from model to large-size. This large-scale effort, which is needed to validate the design of the advanced blades and provide data for the improvement of the analytical prediction capability, will involve both ground and flight testing. The flight test vehicle will be a modified Gulfstream II aircraft with the propfan propulsion system mounted on one wing in a tractor-type installation. In addition to providing propfan structural and near-field acoustic data, the flight test will also provide needed data on cabin interior noise levels. The gearless counter-rotation turboprop propulsion system, referred to as the "UnDucted Fan," or simply the UDF, will also be evaluated in large scale through the ground test phase. Concurrent counter-rotation engine/flight studies, a geared C-R model propeller data base, and results from the gearbox technology program will be used together with the UDF results to arrive at a decision on which system merits further support for a possible flight evaluation subsequent to the single-rotation Propfan Test Assessment (PTA) flight test in 1987.

#### INTRODUCTION

The fuel consumed by U.S. commercial aviation has tripled in the past decade primarily because of the growing use of jet aircraft having greatly improved comfort, speed, and reliability

over earlier, more fuel conservative but slower aircraft. Although future fuel usage is uncertain, the most conservative projections indicate more than a doubling of the fuel required for air transportation by the year 2000.

For many years prior to 1973, jet fuel costs were 10 to 13 cents/gal. Then, in November 1973, previous concerns about a dwindling petroleum supply were emphasized by the OPEC oil embargo and the resulting energy crisis. This and a subsequent crisis in Iran led to fuel allocations and a major escalation in fuel prices. While the fuel allocations have disappeared, and current fuel supplies are relatively abundant, the fuel price appears to have stabilized at around \$1/gal. Despite a rise in nonfuel-related cost components included in the direct operating cost (DOC) computation, fuel costs now account for over half of the DOC figure for the commercial airline fleet, whereas in 1972 they accounted for only about one-quarter of the total. Economic dislocations caused by the high fuel prices persist and constitute a serious problem for the air transport industry. Although it is predicted that any further fuel price increases will be more moderate than in the recent past, emphasis on fuel economy is certain to continue as a major factor in aircraft design for the foreseeable future.

The importance of fuel efficiency in future aircraft designs leads to a consideration of advanced turboprop concepts. Old turboprops, such as those found on the Lockheed Electric/P-3 Orion and C-130 (upper left part of fig. 1), were fuel efficient up to airspeeds of slightly over Mach 0.6. Beyond these speeds,

however, these propellers experience a rapid increase in compressibility losses due to their thick, unswept, large-diameter blades. Their propulsion efficiency is high at lower speeds due to their low power loading ( $\text{SHP}/D^2$ ) which imparts only a small increase in axial velocity to a large mass flow of air and, as shown in Fig. 2, is much higher than the propulsion efficiencies achieved by modern high bypass turbofans up to the Mach 0.6+ turboprop compressibility limits. A possible solution to the speed limitations of current turboprops is the advanced turboprop (or propfan) shown in the lower right-hand part of Fig. 1. This propfan design incorporates very thin, highly swept blades integrated with an area-ruled spinner to minimize both compressibility losses and propeller noise during high-speed cruise. High disk power loadings (at least double those of the Electra) are required for high-speed cruise to minimize propfan diameter and weight and allow easier integration with the aircraft. The higher disk loadings are achieved by increasing the blade count and lengthening the blade chord. The basic reason for the attractiveness of the advanced turboprop concept is that by incorporating design features that minimize compressibility effects at high speeds, installed propulsion efficiencies roughly equivalent to the levels achieved with the old Electra technology can be extended to the Mach 0.8 regime, as shown in Fig. 2. Also alluded to in this figure is the fact that it may be possible to further enhance the basic single-rotation propfan propulsion efficiencies by using swirl recovery

techniques (e.g., by properly contouring the nacelle/wing installation) or by using staged, counter-rotating propfans which can theoretically eliminate the swirl, or nonaxial downstream velocity component, from the propulsion system stream tube. The significance of extending turboprop applicability to the Mach 0.8 regime is that these propulsion systems then become candidates for the whole gamut of subsonic aircraft types up to and including the large commercial transports now powered by turbofan engines. Two possible applications of ATP technology to these large commercial transports are depicted in Fig. 3. Shown are a wing-mounted and an aft-mounted tractor installation. Not shown but also important would be an aft-mount pusher counter-rotation installation.

As shown in Fig. 4, mission studies comparing transport aircraft powered by advanced turboprops against similar aircraft powered by equivalent technology turbofans indicate that advanced turboprops can produce block fuel savings ranging from 15 to 30 percent. At intermediate stage lengths, fuel savings of 15 to 20 percent are expected for single rotation propfans with no swirl recovery, with the benefits depending to some extent on the choice of cruise speed. Benefits are projected to be even greater if swirl can be eliminated without excessive weight penalties, whether by swirl recovery techniques applied to single-rotation systems or by the use of counter-rotation propulsion systems. At long stage lengths, the savings are somewhat greater because the airplane fuel fraction is higher. Likewise, for short hops the savings are greater because a

longer portion of the flight is spent at low speeds where the turboprop efficiency advantage is greater than at cruise speeds.

Fuel savings capability can have significant impact on airline profits and/or losses since fuel burned is by far the largest contributor to direct operating cost, accounting for over half of these costs. To put the significance of a 20 percent fuel savings into perspective, such a savings applied to the domestic fleet of B727, B737, and DC9 aircraft in 1981 could have saved a total of \$1.1 billion, as shown in the left half of Fig. 5. If the savings had been applied to just the 727 part of the fleet, it would have eliminated the \$441 million U.S. airline industry deficit accrued in 1981 and caused a substantial profit to be realized. As shown on the right-hand side of Fig. 5, there is estimated to be a foreign market potential for 2000 new short/medium range aircraft by the year 2000 which U.S. industry could capture with aircraft designs utilizing advanced turboprop technology. Capture of this market would produce a \$50 billion favorable trade balance for the U.S.

The objective of the NASA Advanced Turboprop Program, as stated in Fig. 6, is to establish both single-rotation and counter-rotation propfan technology for Mach 0.65 to 0.85 applications. As mentioned previously, the 15 to 30 percent fuel savings potential relative to equivalent technology turbofans and the ensuing 7 to 15 percent reduction in DOC are the major benefits that would accrue from the development of this technology. But before the technology will be accepted and applied by industry, NASA must demonstrate the safety and reliability

of the critical elements of the system and that cabin noise/vibration levels similar to today's turbofans can be established. To achieve the cabin interior noise goal of 80 to 85 dB, approximately 25 dB of acoustic suppression beyond that used in current turbofan-powered aircraft will be required. Consideration also will have to be given to isolating any turbo-prop induced vibrations from the cabin interior. In addition, far field noise levels must be assessed in order to assure that FAR 36 Stage 3 noise rules can be met. In order for the U.S. to capture the market and become the beneficiary of the favorable trade balances referred to earlier for advanced turboprop aircraft, it is essential that the NASA program demonstrate technology readiness by the late 1980's.

As shown in Fig. 7, the development of advanced turboprop aircraft involves not only the propeller/nacelle, but the drive system, installation aerodynamics, and noise/vibration as well. Optimization of many of these technologies will involve trade-offs between performance, component weight, comfort, and environmental impact which can only be assessed in terms of overall aircraft fuel savings or DOC reduction relative to equivalent technology turbofan-powered aircraft. The development of the required turboprop technologies was approached as a systems problem by NASA in organizing the Advanced Turboprop Project Office at the Lewis Research Center, which is responsible for managing and coordinating the work done by the various NASA field centers, as shown in Fig. 8, according to their areas of expertise. Work under the cognizance of the field centers is

accomplished by a combination of in-house, contract, and university grant efforts. In the implementation of the program plans and objectives, considerable involvement is maintained with the domestic airframe and propulsion manufacturers via contracts and advisory councils in order that industry, as the ultimate source of products utilizing these technologies, will be aware of their status and availability.

#### OVERVIEW OF ATP PROGRAM

In response to a request from members of the Senate Committee on Aeronautical and Space Sciences, NASA formed an Advisory Board in 1975 to plan programs that could result in conservation of fuel used by U.S. commercial aviation. The Advisory Board formulated preliminary plans for major NASA-sponsored programs in propulsion, aerodynamics, and structures. Within the propulsion category, the Board included the following:

- Energy Component Improvement (ECI)
- Energy Efficient Engine (E<sup>3</sup>)
- Advanced Turboprop (ATP)

The first two components of the propulsion segment of the NASA aircraft energy conservation program (ECI and E<sup>3</sup>) have been successfully completed, and have led to improvements to existing turbofan engines and a new generation of more fuel efficient high-bypass-ratio turbofans. The third component (ATP) is thus far the least exploited aircraft propulsion fuel

conservation technology but, nevertheless, has the potential for providing the greatest improvement. It is also the most technically challenging.

The ATP Program was formulated to develop the technologies that will lead to the 15 to 30 percent fuel savings projected for advanced turboprop propulsion systems over comparable technology turbofan engines in high-speed subsonic cruise applications. The major elements of the program plan in schedular format are shown in Fig. 9. The program is divided into the following three major categories:

- (1) Large-Scale Single Rotation;
- (2) Counter Rotation; and
- (3) Subscale Supporting Technology.

The first major element shown is for the large scale single-rotation propfan effort which was initiated in FY 1981. It consists of the Large-Scale Advanced Propeller (LAP) contract with Hamilton-Standard and the Propfan Test Assessment (PTA) contract with Lockheed-Georgia. The LAP contract provides for the design, fabrication, and ground test of the SR-7L propfan, which is a nine-foot-diameter advanced propeller with eight thin, swept blades and a contoured, area-ruled spinner. The first delivery of an SR-7L propfan assembly to the PTA contractor will be made in early FY 1986 so that it can be evaluated in static ground tests with a turboshaft drive system/nacelle installation prior to wind tunnel and flight evaluation in a wing-mount tractor installation. The initial flight testing effort aboard a modified Gulfstream II airplane will occur in 1987 and will



verify the structural integrity of the propfan throughout the flight envelope and allow an assessment of the levels of cabin noise and vibration that exist without cabin acoustic treatment. The low speed part of the PTA flight testing will also provide an initial assessment of the far field noise produced at FAR 36 measuring stations. The subsequent acoustic flight planned for 1988 will evaluate the capability of advanced cabin acoustic treatments in reducing interior noise to levels comparable to today's turbofan-powered aircraft. The focused large-scale effort is an outgrowth of the continuing subscale model research and analytical effort of a more generic nature, as represented by the last bar under Support Technology on Fig. 9. This supporting technology effort encompasses blade aerodynamics, acoustics, and aero-elasticity; installation aerodynamics, including evaluation of inlet and nozzle designs; and cabin noise and vibration. In addition, the supporting technology effort has been expanded recently, as evidenced by the next-to-last bar in Fig. 9, to enhance gearbox technology through gearbox design and component experiments to develop light-weight, efficient, and reliable gearboxes of both single- and counter-rotating designs with capability for transmitting 12 000 to 15 000 SHP.

The second major work element shown in Fig. 9, which is the focused counter-rotation effort, is divided into work related to a unique gearless pusher configuration and also counter-rotating turboprop configurations utilizing the more conventional geared drive system approach. In addition to the effort for the large-scale gearless UnDucted Fan (UDF) powerplant under contract to

General Electric, the gearless counter-rotation work also includes directly applicable subscale wind tunnel model tests of several configurational variations of possible UDF blade assemblies. Under the geared counter-rotation effort a model data base will also be established to provide information leading to a decision in FY 1987 regarding which counter-rotating system merits further effort that would possibly culminate with a flight test. A parallel systems study effort will be performed during and subsequent to the UDF ground test phase and the geared model propfan testing to better compare their projected performance as flight propulsion systems. These and the gearbox technology results under the Supporting Technology effort will also be factors considered in arriving at a decision on the approach to be used in the counter-rotation flight test.

#### TECHNOLOGY PROGRAM

Initial effort on determination of the feasibility of advanced thin, swept, multibladed propellers began at NASA Lewis in the mid-1970's. It consisted of aircraft/engine system studies and initial wind tunnel evaluations of the aerodynamic and acoustic characteristics of subscale propeller models. The high efficiency levels achieved with the model propellers together with very favorable benefit study results led to a decision in 1978 to expand the technology effort to develop a comprehensive data base that addresses all of the system technology concerns listed on the Supporting Technology element at the bottom of the Fig. 9 schedule. The results obtained from these analytical and

experimental efforts to date are reassuring and support the initial conclusion that no other propulsion system can rival the fuel-savings potential of the advanced turboprop for applications in the Mach 0.65 to 0.85 cruise regime of interest. In addition to technology support for the basic single-rotation propfan concept, this element has been augmented to accelerate counter-rotation propeller and drive system technology.

### Propeller Technology

Several 2-foot diameter single-rotation propeller models have been wind tunnel tested and the results established the potential to achieve the predicted 80 percent propulsive efficiency using thin, highly-swept blades. Figure 10 is a collage of photographs showing three 8-bladed and two 10-bladed configurations that were wind tunnel tested to determine the effect of blade sweep and blade count on efficiency and source noise. A better comparison of some of the blade planforms investigated is provided by the side-by-side display photo of Fig. 11. In addition, some models were mounted atop a JetStar aircraft fuselage and flight tested at NASA-Dryden Flight Research Facility (fig. 12). A Lear Jet chase plane was used to acquire far-field noise data while near-field data were acquired with microphones implanted on the JetStar airframe. The flight data indicate that propfan noise propagates as an acoustic wave rather than a shock wave but that weak shocks occur at distances up to 25 propeller diameters away.

The importance of sweep in improving propulsive efficiency and reducing source noise is shown in Fig. 13 for both Mach 0.7

and 0.8 cruise speeds. The analytically predicted curves have been corroborated by the model propeller wind tunnel test data, as shown for the unswept SR-2 and the swept SR-3, both of which are thin blade designs. Sweep is especially important in achieving significant reductions in propeller source noise and also provides moderate improvements in efficiency. Analysis has also demonstrated the need for thinness at the high-speed cruise conditions of interest. This need is brought into focus by Fig. 14, which on the left-hand side shows the benefit of thinness in terms of an increase in cruise propulsive efficiency and on the right-hand side in terms of a reduction in near-field noise. Two levels of thickness distribution are shown in this figure. The T1 thickness distribution represents the thin blade technology which is an ATP goal, whereas the thicker T2 distribution is presently attainable without serious question at a thickness-to-chord ratio only slightly reduced from that of the Mach 0.6 Electra/P3 propeller. The right-hand plot of Fig. 14 shows that although blade thinness has some benefit in reducing source noise, it is not nearly as important in this regard as the effect of sweep. The primary rationale for thin blades, therefore, is to obtain higher propulsive efficiency. Both blade sweep and thinness are required to obtain maximum mission benefits - even at cruise speeds as low as Mach 0.7, as shown in Fig. 15. In this fuel savings comparison relative to current technology thinness and zero sweep, the fuel savings due to reduced fuselage acoustic treatment weight for advanced blades at a constant low interior noise level are added to the fuel

savings due to the propeller efficiency improvements shown in Fig. 14.

Although the effect of increasing blade sweep is positive in terms of improvements to propulsive efficiency and acoustics at high flight speeds, there are structural and aeroelastic concerns that arise because of it. One structural concern relates to steady state stress levels due to centrifugal and steady aerodynamic loads. The centrifugal stress component increases with sweep because of the restoring moment associated with the overhung mass - tending to straighten the blade as rotational speed is increased. The analytic curve shown in Fig. 16 indicates that the magnitude of the increase can be high if blade geometry and materials are held invariant. Of course, in a real design situation these variables are not held fixed in order to partially mitigate this adverse trend.

There are three propfan blade aeroelastic concern areas, as indicated over a typical flight envelope in Fig. 17. Stall flutter is a cyclic stall-unstall-stall phenomenon that occurs only at static or low flight speeds. Classical flutter is a dangerous phenomenon that occurs only at high speeds - beyond Mach 0.6. Forced excitations occur over the entire flight envelope and are caused by unsteady, unsymmetrical airflows produced by gusts, upwash from the wing, and airframe induced flow field distortions. Peak forced excitations occur at low speed climb and high speed cruise conditions. Of particular concern with swept blades at high flight speeds is the possible onset of classical flutter. The flutter boundary shown as a function of

cruise Mach number and tip sweep in Fig. 18 is not very well defined. The anticipated flutter boundary is one reason why the sweep of the SR-7 designed under the LAP contract is being limited. Although analytic codes are in use to predict the flutter boundaries of advanced swept blades, the reliability of these predictions is somewhat questionable because of the difficulty of structurally modeling the spar/composite shell construction of a full-size blade (see blade sketch in fig. 17) which is cambered and twisted and flexes under load. Prediction of the type of flow field to be encountered in an actual installation, especially in terms of unsteady aerodynamic loads that will be imposed, also complicates the prediction of a flutter boundary. Experimental wind tunnel subscale structural/aeroelastic modeling is also questionable because of the difficulty of simulating large-scale construction techniques (e.g., the minimum gauge problem with the shell) at reduced scale. Large-scale testing, therefore, is necessary to validate the structural integrity of these advanced designs.

The propeller technology effort was recently expanded to include more work related to counter-rotation systems. An example is the completion by Hamilton Standard of acoustic and aeroelastic flight tests of the counter-rotation propellers powering the Fairey-Gannet aircraft. The Fairey-Gannet is shown in Fig. 19 during acoustic flight tests with the NASA Lewis Learjet to obtain far-field directivity data. A microphone boom

was mounted under the wing of the Fairey-Gannet to obtain near-field noise data. Subsequent aeroelastic flight tests were completed in April 1984 with the propeller blades strain gauged to determine their dynamic response to several different flight conditions.

#### Installation Aerodynamics

As early as 1976, concern over the likelihood of severe adverse interference penalties prompted a NASA wind tunnel investigation of the effect of a simulated propeller slipstream ahead of a swept supercritical wing. The results, although inconclusive, indicated that the effect of the propeller induced swirl was a major factor in aircraft cruise drag. More recent wind tunnel tests using a small-scale powered propeller on a semi-span aircraft model have provided a clearer understanding of the propeller/slipstream/nacelle/wing interactions. These tests identified several techniques to better integrate the propeller and nacelle with the wing. Use of these techniques results in drag penalties comparable to those of turbofans. One technique involving the addition of a wing leading edge extension (LEX) and fillets (fig. 20), has been simulated in wind tunnel testing at NASA Ames. Results for an under-the-wing installation indicate that the installation drag increment due to the propeller slipstream effects can be eliminated by the LEX and fillets with the only drag penalty associated with the turboprop being that due to nacelle skin friction. Further improvements are expected through nacelle contouring and LEX

droop. Efforts to develop and apply analytical methods addressing installation effects are also under way. Efforts have also been initiated to analyze and experimentally investigate aft-pusher, counter-rotation configurations. Such an arrangement yields a "clean" wing but introduces new problems involving wake ingestion through the propeller blades from nacelles and other upstream aerodynamic surfaces, engine exhaust surrounding the gearbox and pitch change mechanism, engine exhaust passing through the propeller blades, and possible aircraft stability and control problems due to the aft location.

Another vital concern addressed in the NASA installation investigations is that of inlet and diffuser performance in the presence of the propeller flow field. The performance of various types of inlets, some of which are depicted in Fig. 21, has been experimentally evaluated in joint NASA/industry test programs with Lockheed-Georgia, Hamilton Standard, United Technologies Research Center, Boeing, and Pratt & Whitney. Tests were performed with single-scoop, twin-scoop, and annular inlets. Trade studies were performed to determine the propeller inlet area to obtain the optimum balance between external and internal diffusion losses for maximum pressure recovery and acceptable distortion at the compressor face. The effect of a boundary layer diverter on the inlet flow was also investigated, as was the importance of cowl shape on the external flow field in the transonic region. In general, the results of these tests indicate that very good pressure recoveries with acceptable distortion levels can be achieved with single-scoop inlets of



either the shaft penetration or wrap-around type. It was also found that the addition of a boundary layer diverter of the proper height significantly improves inlet pressure recovery and reduces flow distortion at the compressor face. Results with annular inlets were not as encouraging because of their shallow height requirement which induces a boundary layer build-up and resistance to flow. Although the relatively large overall height typical of a single-scoop inlet is beneficial to internal flow, preliminary results indicate that at high flight speeds there is a danger of high blade stress due to higher order excitation caused by the proximity of such an inlet. These blade excitations can be alleviated by increasing the axial spacing between the propfan and inlet at the expense of some reduction in pressure recovery.

#### Cabin Environment

One of the major concerns for any future turboprop airplane that competes in the marketplace against quiet, smooth riding turbofan-powered airplanes is the level of cabin noise and vibration. Passenger comfort levels with past turboprops has been less favorable than with turbofans, and propfans are not likely to alleviate this negative aspect without substantial advances in noise reduction technology. Propfan source noise is expected to be on the order of 145 dB (fig. 22). To achieve a cabin environment comparable to current turbofan transports (about 82 dBA) a reduction of 50 to 55 dB is required. This is about 25 dB beyond the capacity of conventionally treated fuselage sidewalls.

Langley Research Center has initiated several noise reduction activities, including the evaluation of advanced sidewall concepts, precision synchrophasing, active noise suppression, and the determination of structure-borne (versus airborne) noise paths. The latter is important because preliminary tests using a Twin-Otter airplane with a fuselage wrap airborne noise barrier (fig. 23) indicate that substantial levels of acoustic disturbances are carried into the cabin via the airplane structure, thus setting a "noise floor" on the order of 10 dB below the airborne levels. Thus if the desired interior noise level is more than 10 dB below the airborne level, both the airborne and structure-borne noises will have to be attenuated.

The degree of conventional sidewall attenuation was measured with a Swearingen Metro fuselage inside a static acoustic test facility and compared with noise prediction theory as shown in Fig. 24. While the agreement between theory and experiment is good at the higher harmonics, the agreement is poor at the more important fundamental blade passage frequency. These discrepancies are being addressed with more refined analyses that account for boundary layer refraction, wing diffraction, unsteady blade loading, and nonlinear sound propagation. These analyses are being supplemented by high speed acoustic wind tunnel model tests and flight tests. The high speed flight tests involved model propellers mounted atop a JetStar (lower left photo, fig. 24), as mentioned earlier, and provided general

agreement between source noise theory and near-field measurement. Far-field measurements also verified that the pressure disturbances behave as acoustic waves rather than more troublesome shock waves.

### Drive System

Two elements of the NASA propfan drive system technology effort are shown in Fig. 25. One of these is the blade pitch change mechanism. Because the propfan concept involves very wide chord blades, the twisting moments that must be applied when changing pitch are considerably greater than for a conventional propeller and therefore require much more actuator force. Another complication for the pitch change mechanism is introduced by counter-rotation arrangements since twice as many components are required. Worse yet, although in-line gearboxes are preferred for counter-rotation because they are simpler and lighter than the offset types usually used in single rotation applications, they limit accessibility to current technology pitch change mechanisms. Thus, either maintenance costs rise or alternative pitch change concepts need pursuit. The latter choice is preferable and is the subject of two on-going NASA-sponsored studies which show that the pitch change mechanism can be designed to be autonomous and located in the propeller hub, whether the gearbox is offset or in-line. This is true for either single- or counter-rotation applications, although for C-R maintenance and accessibility is expected to be more complicated than for S-R and may require the removal of the first-stage prop.

Also in progress is the preliminary design of both single-rotation and counter-rotation gearboxes to help identify specific technology requirements. The key problem is the maintenance and reliability shortcomings experienced in past designs and the nonexistence of a large turboprop gearbox (e.g., 12 000 to 15 000 SHP). NASA and the engine manufacturers believe that a large modern gearbox can indeed be constructed that overcomes the previous shortcomings - largely through the use of sophisticated dynamic system analysis tools and design ingenuity - but the airplane manufacturers and airlines require hard data before committing to new concepts. Toward this end NASA is pursuing advanced gearbox technology in several joint government/industry endeavors.

#### LARGE-SCALE PROGRAM

The major focus of the ATP Program at the present time is the large-scale propulsion system evaluation effort encompassing both a single-rotation wing-mounted tractor configuration (LAP/PTA) and a unique gearless counter-rotation pusher design (UDF), as previously discussed in connection with Fig. 9. The main objectives of the single-rotation effort are to verify the structural integrity of the propfan blades and to determine cabin acoustic characteristics. In addition to these objectives, the counter-rotation UDF test program also has the objective of demonstrating the operational feasibility and aeromechanical performance of the unique direct-drive power turbine/propeller/exhaust system concept. The approach used in

accomplishing these objectives is to design and fabricate large-scale propeller assemblies for ground test; flight test a single-rotation, wing-mount, tractor installation on a testbed aircraft; and, if warranted, flight test a suitable counter-rotation propulsion system - either the UDF or a geared propfan design.

In addition to the more generic technology items included in the Support Technology program element shown in Fig. 9, an extensive model test effort in direct support of the large-scale activity is included under that program for both the single and counter-rotation elements. In the case of the single-rotation program, this includes wind tunnel tests of a testbed airplane stability and control/performance/acoustic model and a flutter model, as well as an inlet S-duct diffuser aerodynamic performance model. Also included will be fuselage acoustic panel testing in an anechoic chamber to determine the acoustic attenuation properties of promising lightweight designs. In the counter-rotation program, wind tunnel investigations of several candidate UDF propeller models are being conducted. A parallel propfan model test effort is also being conducted with counter-rotation propfan designs compatible with the more conventional geared drive systems. Airplane system studies will also be performed to evaluate the potential of the various counter-rotating design concepts and identify propulsion related technology needs peculiar to each.

The large-scale UDF ground test results, together with results from the model testing and analytical studies, will allow

a comparative evaluation to determine which counter-rotation system has the most potential and should be pursued further in a flight test evaluation.

#### Single-Rotation

The large-scale single-rotation phase of the ATP Program began in 1981 and initially consisted of (1) testbed aircraft studies to identify existing airplanes and drive systems that could be used for in-flight evaluations of large-scale advanced propfans and (2) blade definition and scaling studies to determine the characteristics of the large-scale propfan blades to be built and tested in the subsequent effort. The testbed studies were done under contracts awarded to Douglas and Lockheed, both of which concluded that suitable airplanes existed for such a test and that engines and gearboxes existed that could, with relatively simple modifications, deliver the power required by a large-scale propfan at the critical high-speed flight condition. They concluded, furthermore, that a testbed airplane flight test approach was indeed the most feasible way to validate propfan structural integrity at high-speed flight conditions since ground test facilities which can accommodate a large-scale propfan and adequately simulate such conditions do not exist. These airframers also concluded that a flight test was the best way to obtain large-scale propfan source noise data to evaluate acoustic scaling techniques, determine cabin interior noise levels, and evaluate methods for the attenuation of such noise.

Hamilton Standard was awarded a blade definition and scaling contract in 1981 to design a large-scale single-rotation propfan to be fabricated and ground tested with facility power in the subsequent Large-Scale Advanced Propeller (LAP) contract awarded in mid-1982. The 9-foot diameter SR-7 propfan design resulting from the LAP program (fig. 26) is a refined version of the SR-3, having about the same tip sweep but somewhat less inboard sweep. It incorporates the spar-shell type of construction illustrated in Fig. 27. All of the Hamilton Standard propellers for new commuter aircraft use straight blades that incorporate a similar spar-shell type of construction which has proven to be very safe, reliable, and lightweight. With this construction, FOD problems inherent in earlier solid aluminum blades are avoided by protecting the single load-bearing spar with an aerodynamically-shaped fiberglass shell. Use of this construction technique for large-scale propfans avoids the need to develop new fabrication processes, thereby enhancing the probability of initial success and industry acceptance, and appears to be satisfactory, based on design analysis techniques. This design methodology, however, is unproven for the thin, swept, composite propfan construction which introduces complex nonlinear blade deflections and the possibility of high-speed classical flutter, thereby reinforcing the need for large-scale testing to verify structural integrity.

In selecting a blade size for the verification of propfan structural integrity the following three considerations are apparent:

- A size as close as possible to full-size should be selected to eliminate concerns about further upward scaling of aeroelastic test data.
- Minimum gauge of the shell used in the spar-shell construction dictates a blade diameter of at least eight to nine feet if realistic scaling of the structural cross-section is to be maintained.
- An engine and gearbox should be available that could, with minimal modifications, meet the power and rotational speed requirements of the propfan.

Since existing drive system capability is limited to about 3000 SHP at the critical high-speed (Mach 0.8, 35 000 ft. altitude) condition, and disk loadings ( $\text{SHP}/D^2$ ) of 30 to 40  $\text{SHP}/\text{ft}^2$  are required, propfan maximum diameters cannot exceed 9 to 10 feet for a near-term testbed aircraft. The band of possible propfan diameters established by the aeroelastic scaling and available power considerations is shown in Fig. 28, together with a plot of approximate full-size propfan size requirements as a function of airplane gross weight. This plot shows that a full-size propfan for a twin-engine installation would have a diameter of 10 to 18 ft., depending on airplane size. These considerations dictated the design requirement of a nine-foot-diameter propfan for the large-scale test program. Structural and aeroelastic scaling capability from the nine-foot test configuration to even larger sizes are thought to be sufficiently reliable to warrant this early test with an available drive system. Structural analysis performed under the LAP contract



predicts that acceptable flutter margin will be obtained over the projected flight profile for this thin, swept SR-7 blade design, as indicated in Fig. 29.

Static testing of the SR-7L propfan assembly will occur under the LAP program on a test stand at Wright-Patterson Air Force Base, Ohio. Facility power will be used to drive the propfan in this test. After this test is conducted under the LAP program, the SR-7L propfan will then be further evaluated as part of a complete propfan propulsion system in the Propfan Test Assessment (PTA) effort (fig.30). The initial effort in PTA will consist of modifying the existing Allison Model 570 industrial gas turbine engines and T56 gearboxes to the PTA drive system requirements and designing and fabricating a flightworthy nacelle compatible with the SR-7 propfan. Late in 1985, these components will be mated with one of the LAP propfan assemblies to form a complete propulsion system. A mock-up of the SR-7L propfan attached to the Allison drive system is shown in Fig. 31. The complete propulsion system minus aft nacelle will undergo ground testing on an outdoor static stand. After completion of the static test, the installed propfan propulsion system will be evaluated in the NASA Ames 40x80-ft low-speed wind tunnel. For the wind tunnel test, the propfan/nacelle/drive system propulsion package will be mounted on a testbed airplane wing semi-span attached to a fuselage barrel section and a right-wing stub to better simulate installation aerodynamic effects. These tests should uncover any tendency of the

propfan blades to encounter stall flutter, which is the predominant aeroelastic concern at static and low-speed conditions. As a part of this testing, propfan near-field acoustic characteristics will be determined and noise transmission paths into the cabin will also be identified. A parallel effort is the selection, acquisition, and modification of a Gulfstream II airplane to convert it to a flying testbed for the propfan. The testbed aircraft, shown in Fig. 32, will be designed to accommodate a tractor-type wing-mount propfan installation, using the same nacelle/propulsion system package and left wing used in the 40x80 wind tunnel test. Note that the existing turbofan engines are retained for primary propulsion. To aid in this testbed design effort, the series of wind tunnel model tests referred to previously will be conducted with both single- and twin-wing-mount propfan installations. The twin-engine data will be used to aid in the design of a large-scale twin-engine configuration which is a possible candidate for the follow-on acoustic flight test scheduled for late-1988 (fig. 9). Particular attention in the model test effort will be devoted to determining the range of propfan excitation factors\* which can be obtained over the expected flight operating envelope at various aircraft altitudes and nacelle angles of incidence. Blade stress data acquired in the flight tests will be correlated against excitation factors based on model test results as well as analytical efforts.

---

\*Excitation factor is a measure of the airflow quality at the propeller plane, as it affects propfan unsteady aerodynamic loading.

The flight tests are intended to verify the structural suitability of the SR-7 propfan design in the areas of rotor vibratory response and classical blade flutter, and determine the acoustic characteristics of the propfan as well as cabin interior noise levels in the vicinity of the propfan plane. Testing will be conducted over a broad spectrum of flight operating conditions and will encompass the Mach 0.8/35 000 ft propfan design condition. Excitation factor will be varied over a range of values up to the propfan design limit by changing aircraft angle of attack or incidence angle of the variable tilt nacelle. Low-speed far-field noise measurements will also be made at typical takeoff sideline and fly-over conditions as well as landing approach to obtain an initial indication of noise levels likely to be encountered in the airport and community environment. After the completion of the structural integrity/bare cabin wall acoustic flight tests in 1987 (fig. 9), a series of follow-on acoustic flight tests is planned for 1988 with one or more advanced noise suppression concepts installed within the cabin walls.

#### Counter-Rotation

The attractiveness of counter-rotating propeller systems derives from their ability to reduce the rotational, or "swirl," losses associated with single-rotation systems. In order to generate propulsive thrust, a single-rotation propeller must take essentially axial flow and turn it in order to do work on it, in much the same way that an airplane wing must turn the flow slightly downward in order to generate upward lift. The

result with a single-rotation propeller is that the discharge flow must have a nonaxial rotational component of perhaps several degrees, depending on disk loading and tip speed. A decrease in net thrust (and, hence, propulsive efficiency) results from this nonaxial velocity component since the total change in momentum is not in the axial direction, as it ideally should be for the production of thrust. As the disk loading is increased to minimize the blade diameter and associated weight, swirl becomes more significant than in older, more conventional designs. This effect can be reduced by increasing the blade tip speed, but this has already been done to the extent desirable in the SR-7 propfan design, which at 800 ft/sec at the Mach 0.8/35 000 ft design point is into the transonic region. Further increases in tip speed will increase the noise level and begin to reduce efficiency. The swirl losses for an isolated SR-7 propfan at design point operating conditions are equivalent to about eight points in efficiency. A similar percentage reduction in fuel consumption could be obtained by the elimination of swirl.

Some of the swirl produced by wing-mounted tractor single-rotation propfan installations can be removed by properly contouring the wing leading edge and nacelle. Essentially all of the swirl can be removed, however, by a properly designed counter-rotation system such that the swirl imparted by the front blade is nearly of equal and opposite direction to that produced by the second set of blades. With a counter-rotation system, additional installation flexibility is available since

there is no dependence on other aerodynamic surfaces to remove swirl. Aft-type pusher installations then become feasible from a propulsive efficiency standpoint, whereas with a single-rotation pusher propfan such an aft-mount location might not be attractive because of the lack of potential for swirl recovery. Aft-mounting may be attractive from a cabin noise point-of-view, however, since it places the noise source aft of the aft fuselage bulkhead. It also would allow a cleaner, more uncluttered wing with possibly better lift-drag characteristics.

The major focus of the large-scale counter-rotation effort at the present time is the design, fabrication, and ground test of the pusher-type gearless UnDucted Fan (UDF) propulsion system, which is shown in the cutaway drawing of Fig. 33. As shown in the schedule of Fig. 9, work on the UDF began in FY 84 and will continue through CY 1986 when the ground test effort will be completed. This new engine concept is being developed by General Electric under a cost sharing contract with NASA. It features an aerodynamically coupled gas generator and counter-rotating power turbine, the latter of which converts the gas generator engine power to that required by the directly-driven propfan without the requirement for the development of a new gearbox or provision for additional shafting. The 20 000-hp-class demonstrator propulsion system uses an F404 turbofan engine (with the augmentor removed) as the gas generator ahead of the "propulsor" unit which contains the turbine rotors, power frames, prop blades, and turbine static structures. The F404 is a fully-developed low-bypass turbofan engine which is used in

the Navy F-18 fighter. Attention in this program, therefore, will be more properly concentrated on developing the propulsor unit. The propulsor prop blades will be designed for a high overall disk loading of approximately  $50 \text{ SHP}/D^2$  at the high-speed cruise point, and for high hub-to-tip radius ratios of about 0.4, whereas more conventional designs have hub-to-tip ratios of 0.15 to 0.25. This high radius ratio is necessitated by the large diameter of the power turbine, which in turn is dictated by the low rotational speed set by the propfan tip speed limitation of approximately 800 ft/sec. The low rotational speed of the power turbine and the power requirement of the 12 ft diameter propeller blades also dictate that 12 counter-rotating stages be included in the power turbine design. Another unique feature of this turbine design is that, except for a set of inlet and outlet guide vanes, there are no stator vanes between the alternating opposite rotation blade rows.

The development of the large-scale UDF propulsion system is supported by an extensive NASA-sponsored model program to verify the aerodynamic and aeroelastic performance and determine the aeroacoustic characteristics of the counter-rotating prop blades. In addition to these model tests, numerous component tests will be conducted prior to the full engine ground test program which will start in 1985. These tests will verify the mechanical design and functional integrity of the major UDF propulsor components, including the power turbine, prop blades, and static structure.

The ground test of the complete UDF engine will be conducted on an outdoor test stand and will provide a data base for engine performance, operability, durability, and acoustic characteristics. The results of the ground test will be used in the comparative evaluation of the UDF concept against other more conventional counter-rotation propfan designs and will serve as a data base which could be used in a possible follow-on flight test evaluation.

As the schedule chart of Fig. 9 shows, NASA is conducting a parallel counter-rotating propfan effort of more conventional designs with a lower hub-to-tip radius ratio, drawing more extensively on experience gained in the single-rotation experimental and analytical effort. These counter-rotational propfan models will be designed, fabricated, and tested under contract by Hamilton Standard. They will be wind tunnel tested on a propeller test rig and evaluated to determine their aerodynamic performance, as well as their acoustic and aeroelastic characteristics. Parallel with this, counter-rotation gearbox technology, as previously discussed in connection with Support Technology, will be accelerated under contracts with Pratt & Whitney and Allison. A geared counter-rotation propfan propulsion system data base will thus be established to aid in the selection of a system for a possible counter-rotation flight test. In the event that the geared propfan system is selected for the flight test configuration, a counter-rotation counterpart to the single-rotation LAP program would be implemented

prior to the flight evaluation to build and assemble the required propulsion system hardware.

#### CONCLUDING REMARKS

Studies and model tests indicate that thin, swept, highly-loaded turboprops applied to high-speed (Mach 0.65 to 0.85) commercial aircraft can produce block fuel savings of 15 to 30 percent relative to advanced turbofans (50 to 60 percent relative to today's turbofan fleet). With fuel prices at around \$1/gal, over 50 percent of the DOC is accounted for by fuel. The fuel savings predicted for advanced turboprop-powered aircraft translates into a 7 to 15 percent reduction in DOC compared to that possible with advanced turbofans. Such fuel savings potential could have considerable impact on airline profits. For instance, a 20 percent fuel savings, which is perhaps a conservative estimate for a wing-mount single-rotation propfan in a tractor-type installation, could have eliminated the \$441 million U.S. airline deficit incurred in 1981 and caused a substantial profit to be realized if applied only to the Boeing 727 part of the domestic fleet. The market potential for short/medium range aircraft with such fuel savings capability is huge. If we could initiate production of these aircraft in the early 1990's, it is estimated that by the year 2000 they could produce a \$50 billion favorable trade balance for the U.S. Delays in acquisition and implementation of the technologies required to realize this potential fuel savings,



however, could jeopardize our head start in this effort and allow foreign competition to erode the apparent United States advantage.

The planned NASA program calls for the flight test of a large-scale single-rotation propfan in 1987 to verify its structural integrity and characterize near-field source noise, as well as to identify acoustic transmission paths into the cabin. The aerodynamic performance advantages of single-rotation propfans have already been verified in tests of small-scale models. Structural integrity and acoustic characteristics, however, cannot be as easily verified at small scale, thereby providing the impetus for the large-scale flight test effort.

A follow-on acoustic flight test is also planned for 1988 to determine the effect of advanced acoustic treatment on cabin interior noise and to demonstrate that cabin noise levels similar to those achieved with today's turbofans can be obtained. An effort is also being initiated to achieve technology readiness in gearboxes, for both single- and counter-rotation designs. This effort is needed for two reasons: (1) gearboxes are not currently available in the 12 000 to 15 000 SHP size that will be required in commercial airline applications, and (2) maintenance and reliability shortcomings have been experienced in the past with gearboxes designed for lower power levels.

Because of their relative simplicity, the NASA program until this year had concentrated on validating the technologies directly applicable to single-rotation propfans, as opposed to

counter-rotation designs. This year, however, a significant joint effort was initiated with General Electric to ground test a large-scale gearless counter-rotation turboprop propulsion system (the UDF). Counter-rotation is attractive because, if properly designed, it can eliminate the swirl losses associated with an uninstalled single-rotation propeller. (Some of these losses in an uninstalled single-rotation propfan can be recovered in a wing-mount tractor installation, however, by properly contouring the portion of the wing and nacelle inside the prop wash.) Additional effort is being applied under a model test contract to Hamilton Standard to better understand the aerodynamic performance of more conventional counter-rotation propfans compatible with geared drive systems. These tests, together with parallel analytical studies and airplane mission comparisons, will allow a decision to be made late in 1987 to determine which counter-rotation system warrants pursuit through the flight test phase. The purpose of such a test would be to bring counter-rotation technology to the same state of readiness as that of single-rotation after the PTA flight test of the single-rotation propfan. Upon completion of the NASA program toward the end of the decade, the airframe and propulsion industry will then have available the technology base required to make a marketing decision regarding the design of possible prototype aircraft, applying whichever technologies appear to be most appropriate for the chosen configuration.

With fuel conservation such a major concern today, and with the potential operating cost savings attributable to the advanced turboprop, it behooves us to advance this technology effort as rapidly as possible to enable the aeronautical community and the public at large to share in these potential benefits.



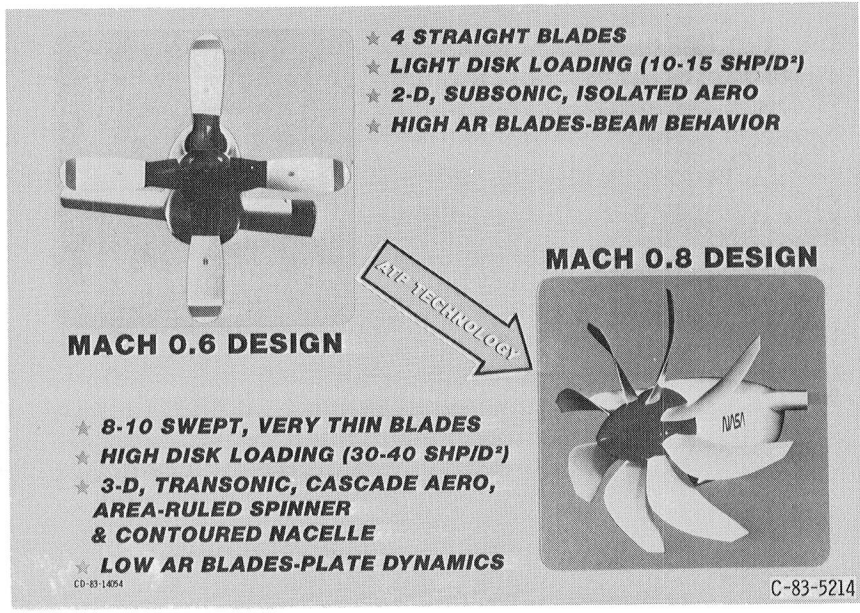

Figure 1. - Route to improved fuel efficiency.

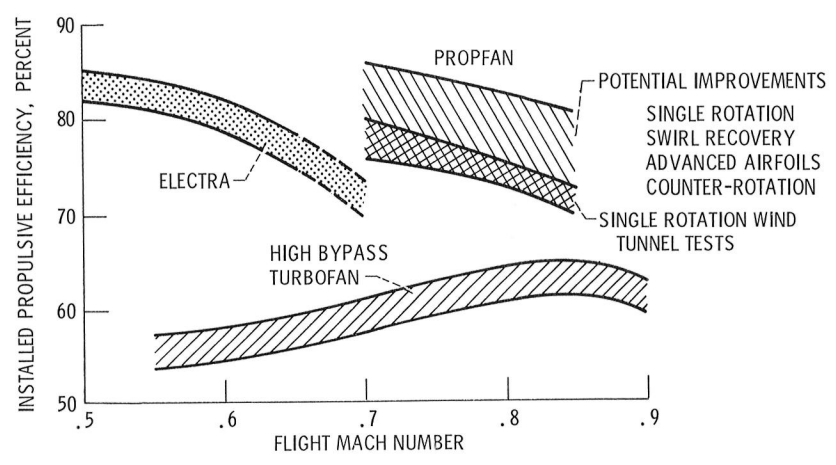

Figure 2. - Comparison of propfan and turbofan propulsive efficiencies.



Figure 3. - Advanced turboprop passenger aircraft.

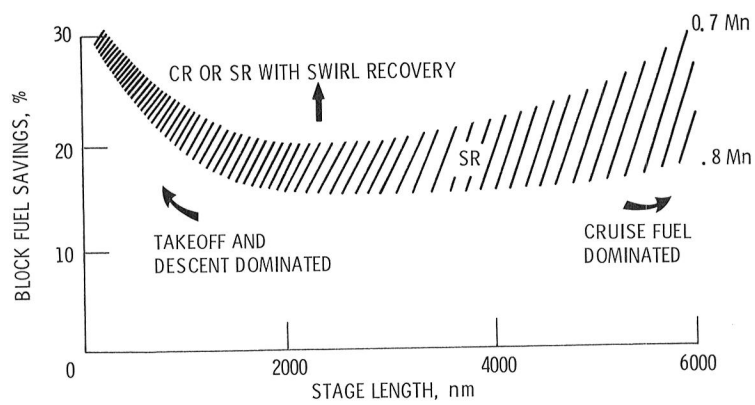

Figure 4. - Potential fuel savings for advanced turboprop-powered aircraft relative to turbofan-powered aircraft with same level of core technology.

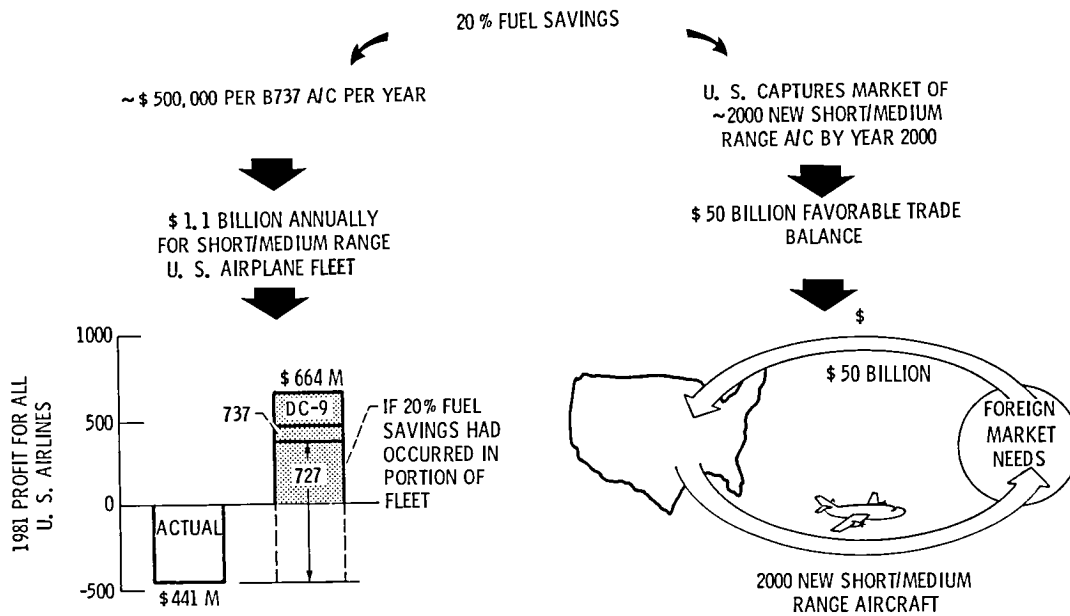
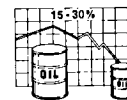

Figure 5. - ATP technology benefits.

OBJECTIVE ESTABLISH SR AND CR PROPFAN TECHNOLOGY FOR MACH 0.65-0.85 APPLICATIONS

PROGRAM BENEFITS/GOALS

FUEL SAVINGS OVER COMPARABLE TURBOFANS



DOC SAVINGS OVER COMPARABLE TURBOFANS

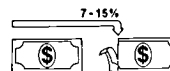

SAFE AND RELIABLE SYSTEM



CABIN NOISE/VIBRATION SIMILAR TO TURBOFAN'S

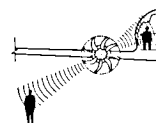

MEET FAR 36-III COMMUNITY NOISE REGS

TECHNOLOGY READINESS BY LATE 1980'S



Figure 6. - Advanced Turboprop Program objective, benefits and goals.

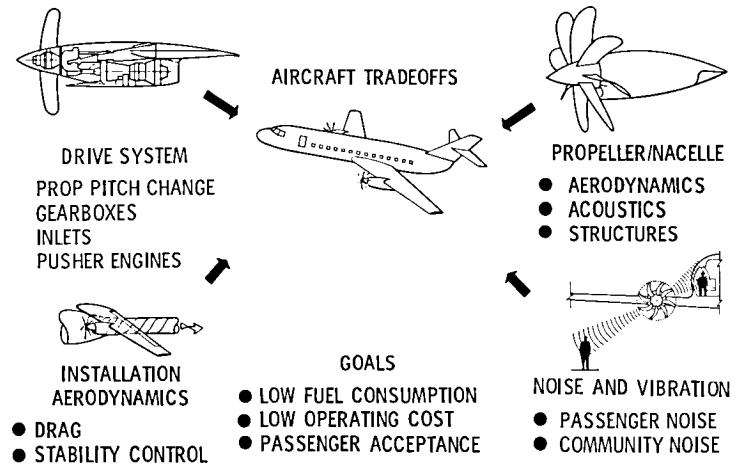

Figure 7. - Elements needed for the development of advanced turboprop aircraft.

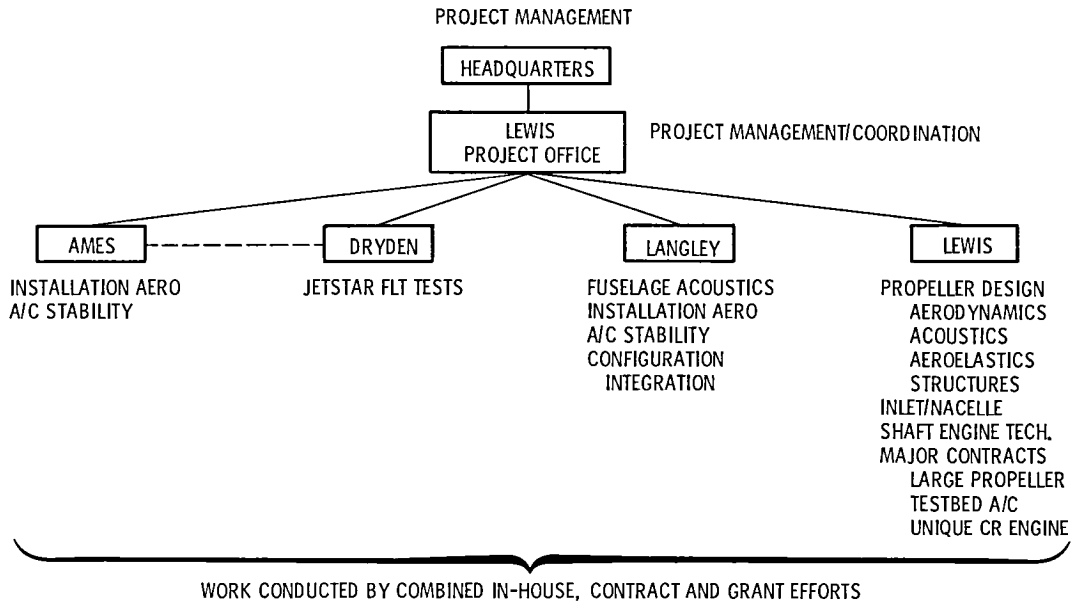

Figure 8. - NASA organizations contributing to the advanced turboprop program.



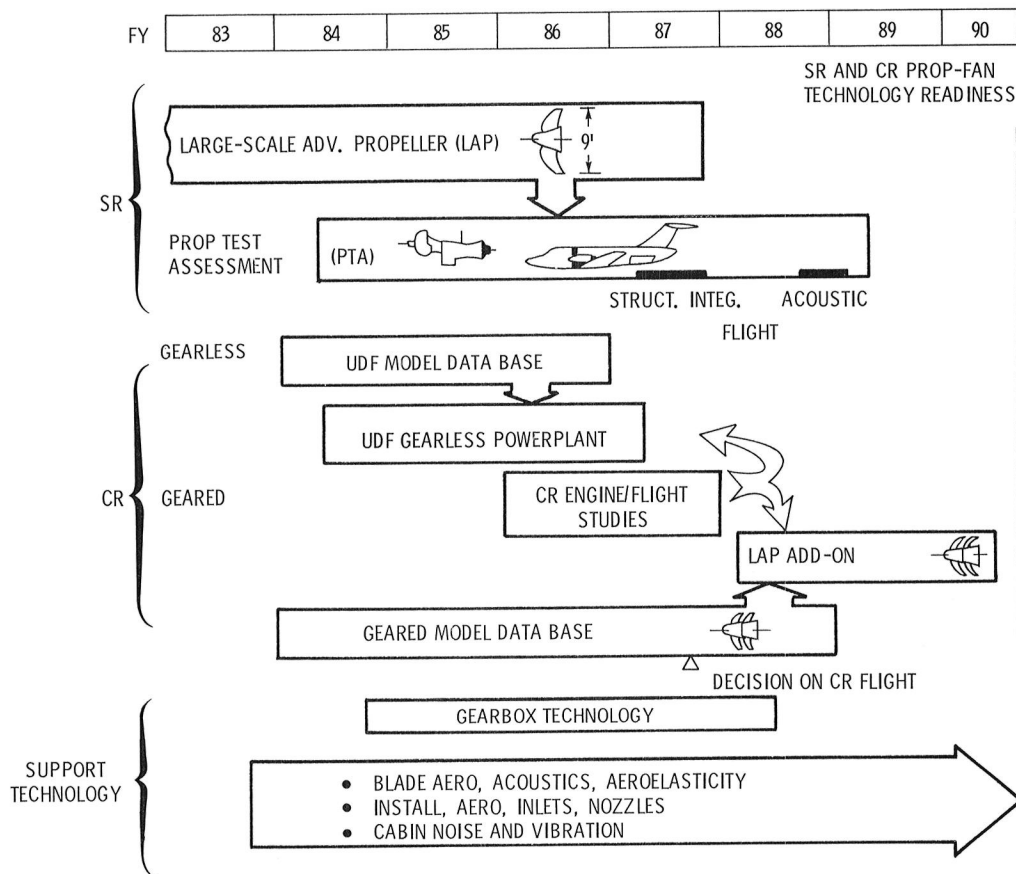

Figure 9. - ATP program plan.

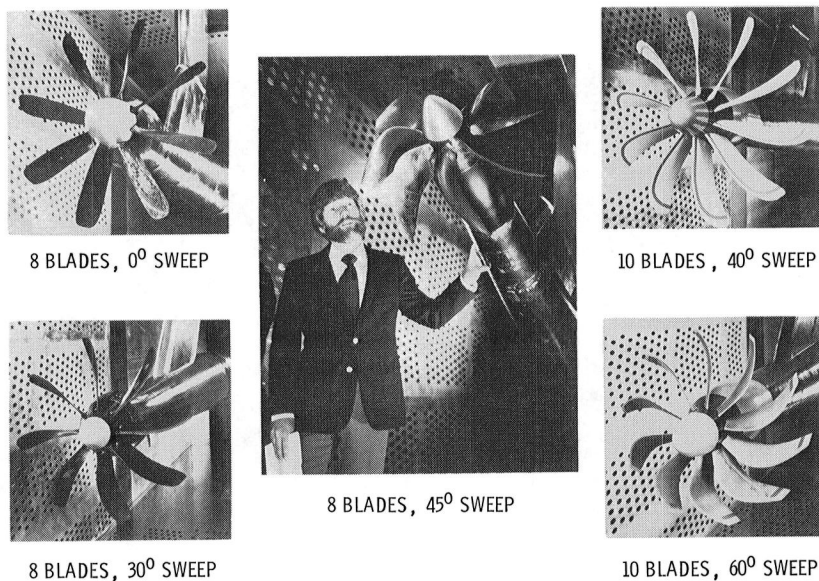

Figure 10. - Propeller models installed in the Lewis 8-by-6 foot wind tunnel. C-81-3151

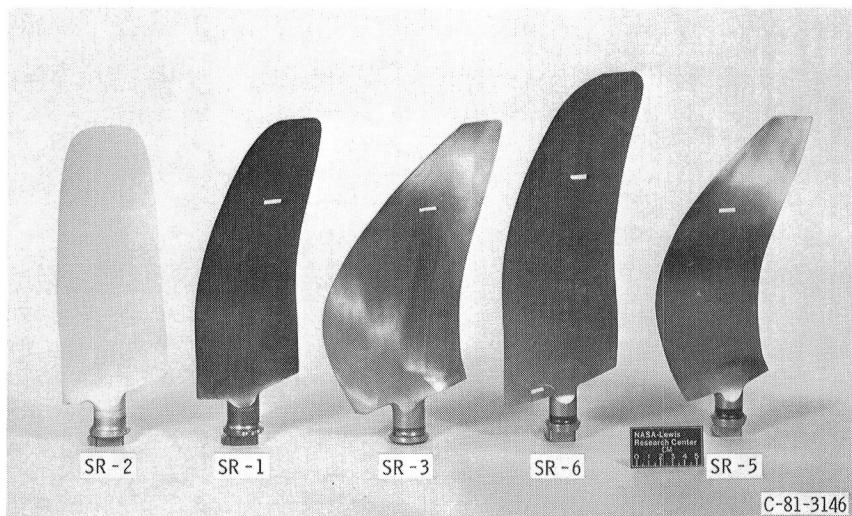

Figure 11. - Advanced propeller blades.



Figure 12. - Far-field acoustic flight tests.

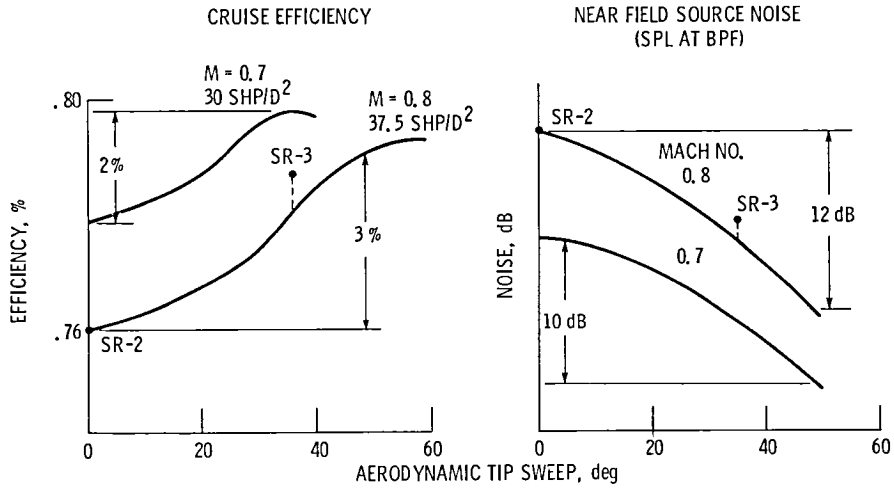

Figure 13. - Effect of blade sweep on propeller propulsive efficiency and noise at 800 ft/sec tip speed.

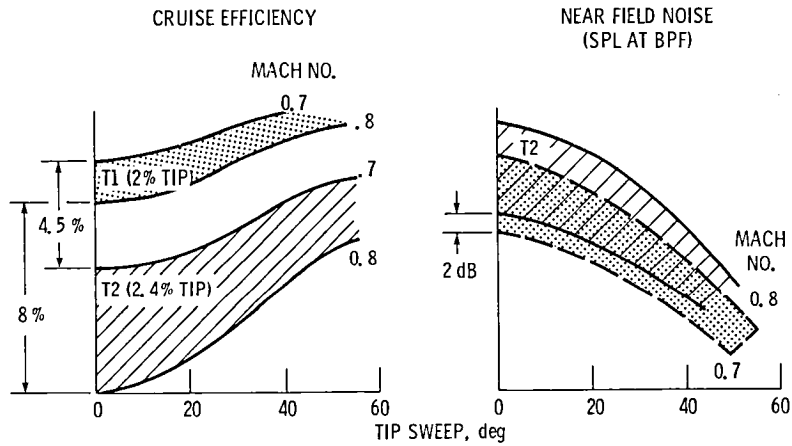

Figure 14. - Effect of blade thickness on efficiency and noise at 800 ft/sec tip speed.

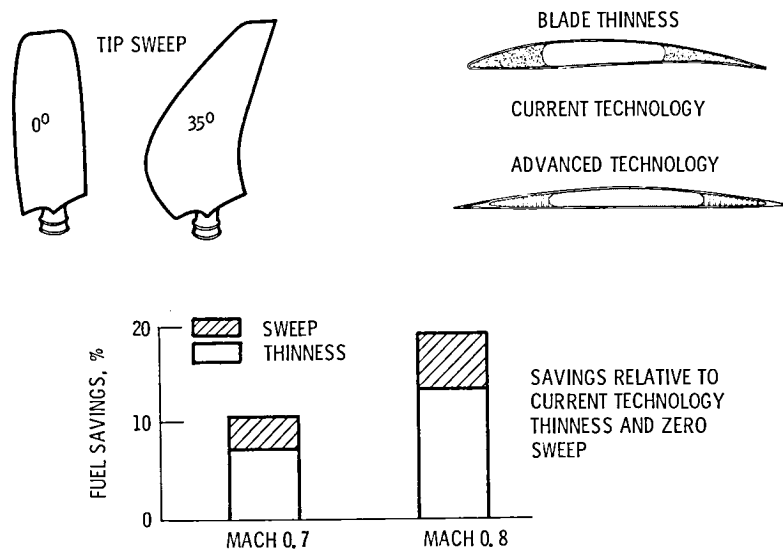

Figure 15. - Effect of blade sweep and thickness on fuel savings at Mach 0.7 and Mach 0.8.

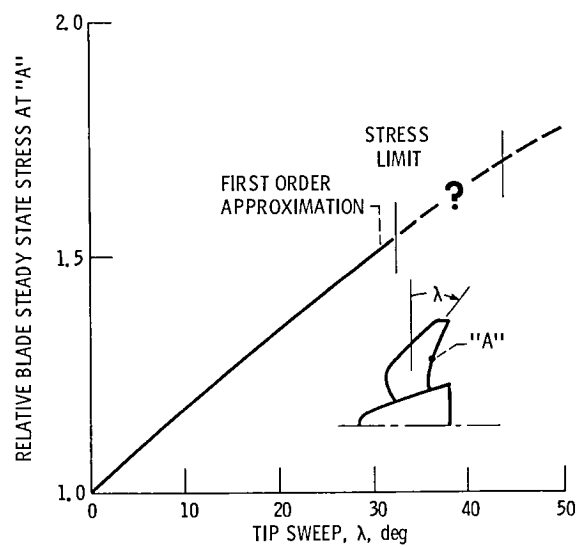

Figure 16. - Effect of sweep on steady stress for constant geometry and materials.

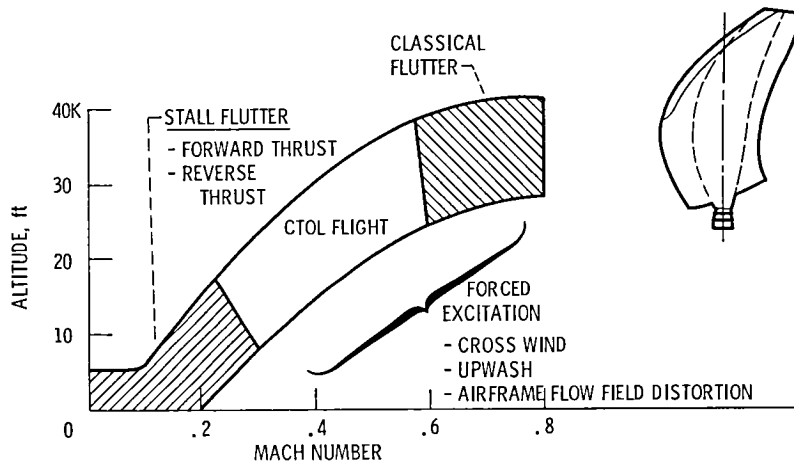

Figure 17. - Propeller aeroelastic concerns.

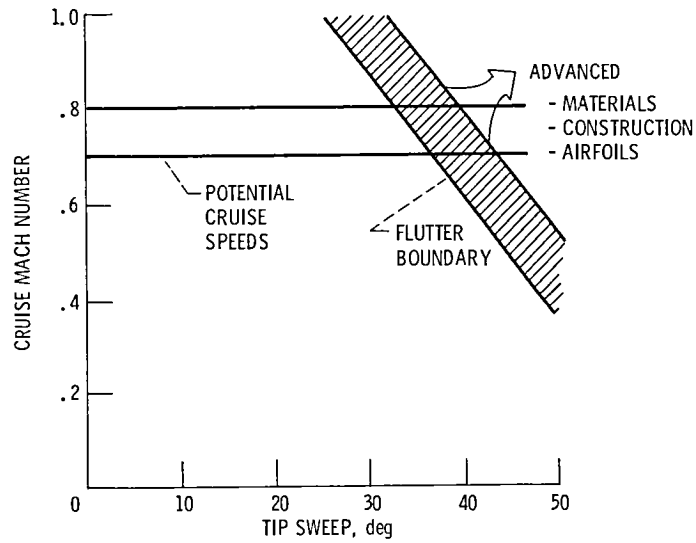

Figure 18. - Effect of sweep on flutter Mach no. at 800 ft/sec tip speed.

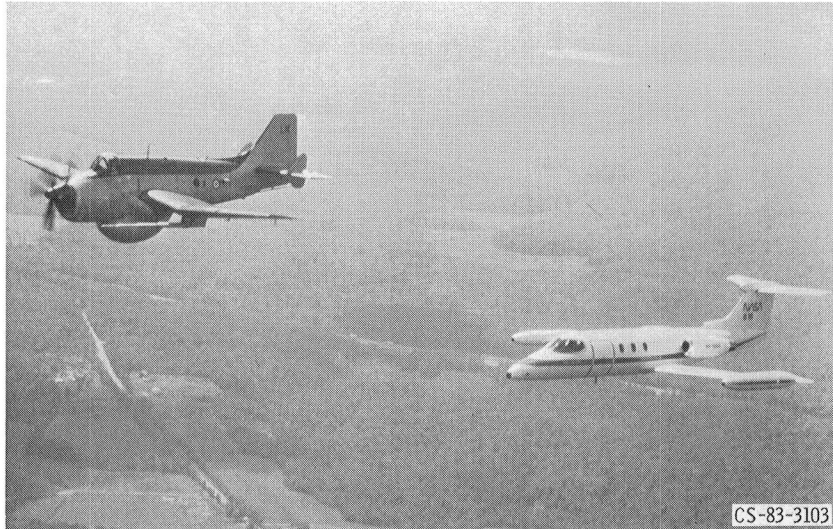

Figure 19. - Fairey Gannet (CR prop) and Learjet in flight.

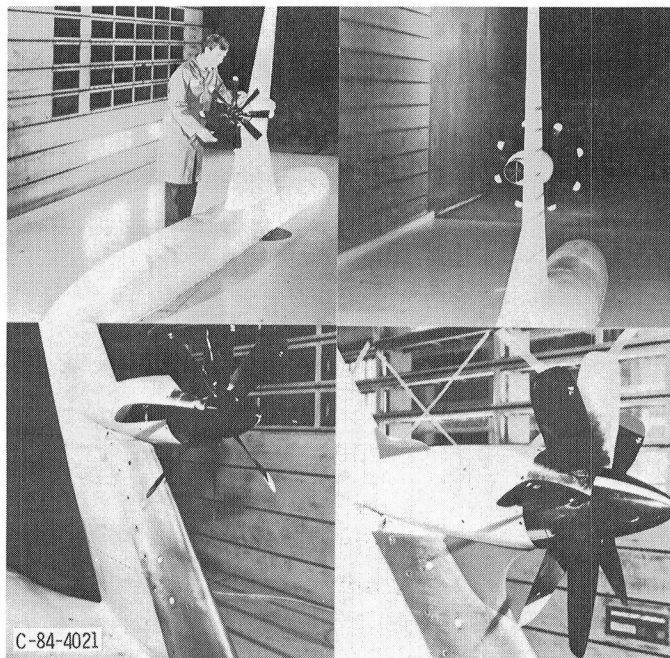

Figure 20. - Propeller and wing model showing leading edge extension (LEX) and fillets.

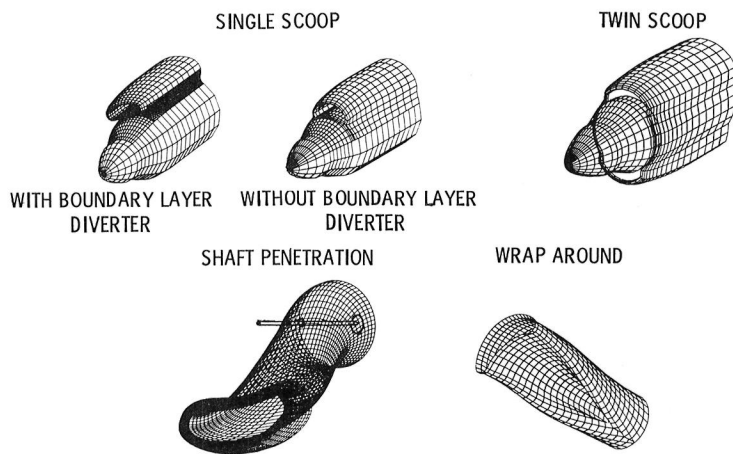
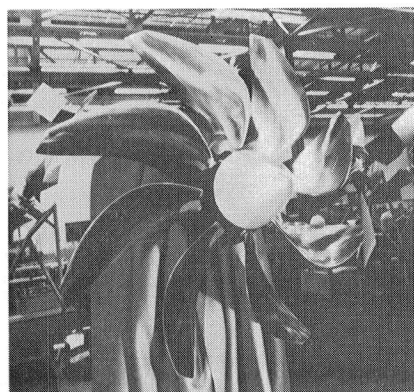

Figure 21. - Inlets investigated for the Advanced Turboprop Program.



PROPOSED QUIET PROP FAN

- SUPERSONIC SPEED AT PROPELLER TIP
- HIGH EXTERIOR NOISE LEVEL ON FUSELAGE
- ADVANCED FUSELAGE TREATMENT REQUIRED FOR PASSENGER ACCEPTANCE

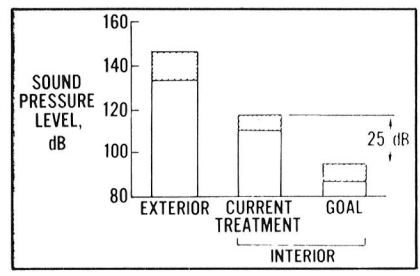

Figure 22. - Depiction of the high speed turboprop interior noise problem.

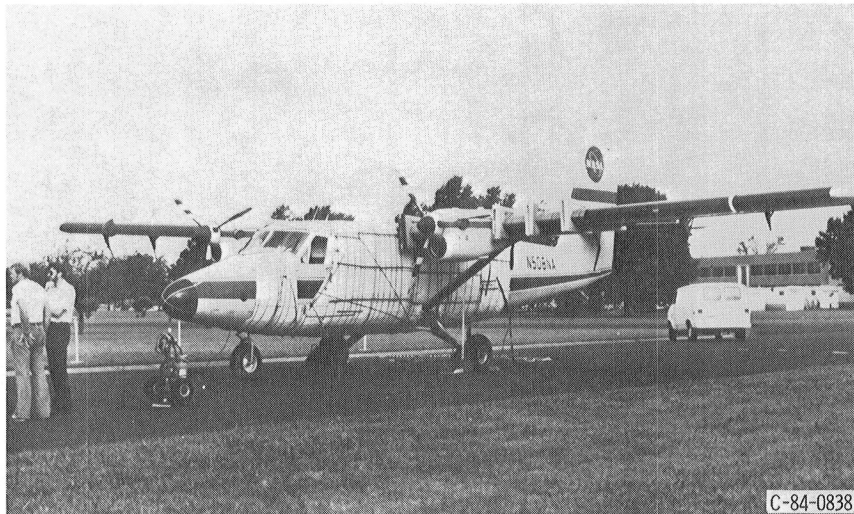

Figure 23. - Twin Otter structureborne noise test.

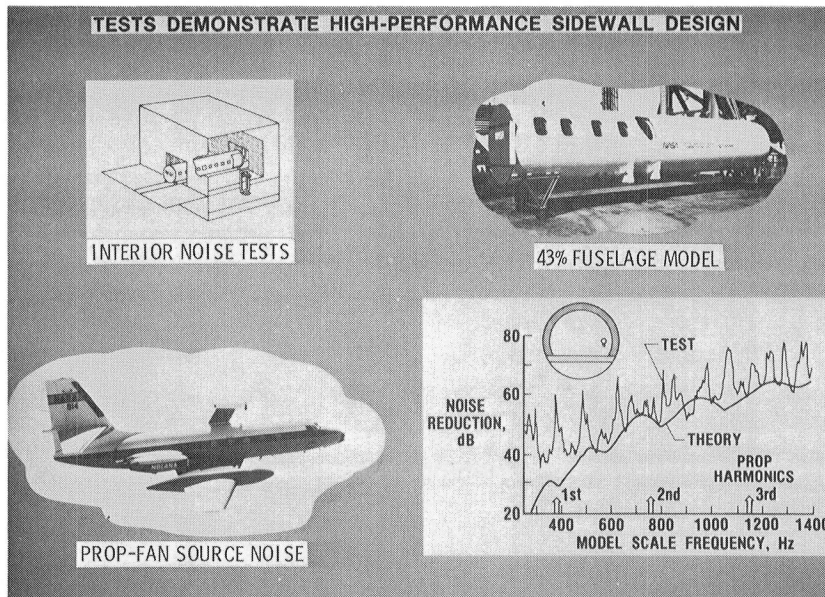
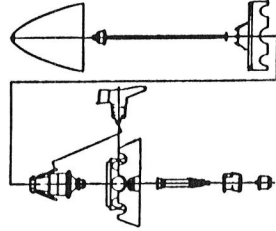

Figure 24. - Depiction of the Advanced Turboprop Program interior noise control activities.



ADVANCED PITCH CHANGE MECHANISM  
HIGH LOADS  
COUNTER ROTATION COMPLEXITY



ADVANCED SR AND CR GEARBOXES  
RELIABILITY/MAINTAINABILITY  
DESIGN INGENUITY

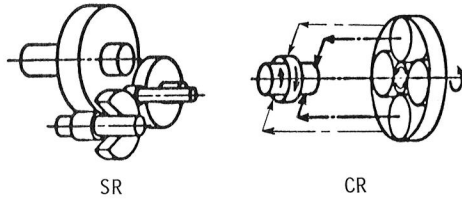
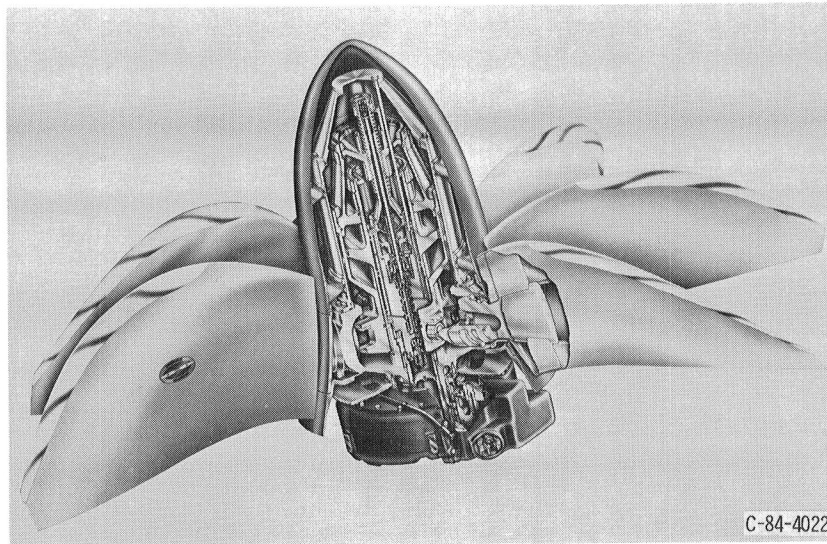

Figure 25. - Elements of the propfan drive system technology effort.



C-84-4022

Figure 26. - Large-scale advanced propeller (LAP).

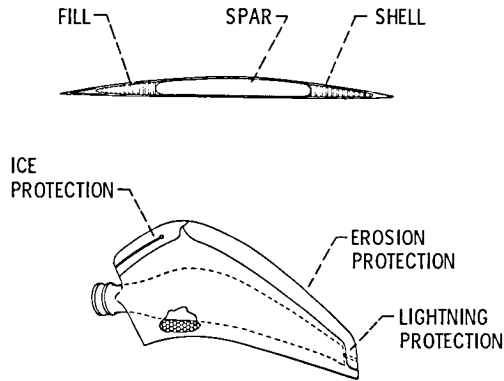

Figure 27. - Schematic of the spar-shell blade construction concept used for the LAP.

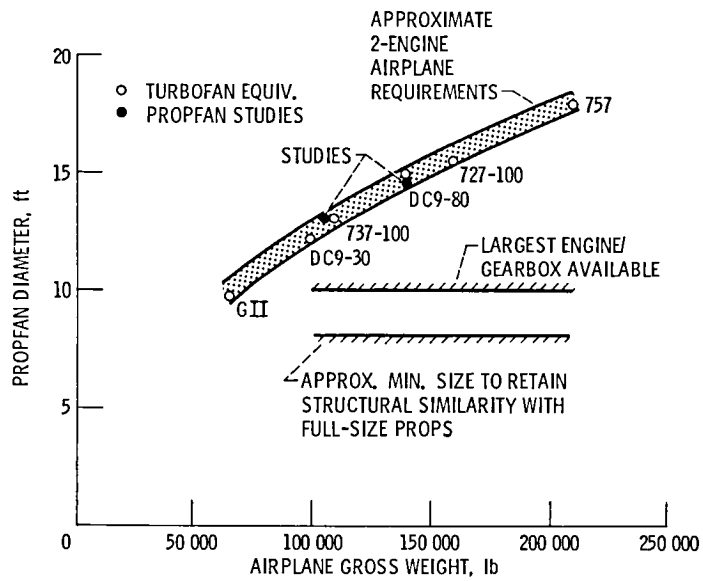

Figure 28. - Sizing of large-scale prop-fan test hardware.

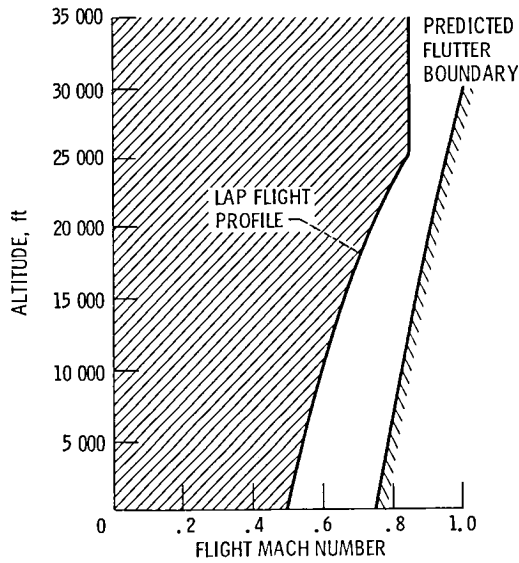

Figure 29. - SR-7 prop-fan stability boundary.

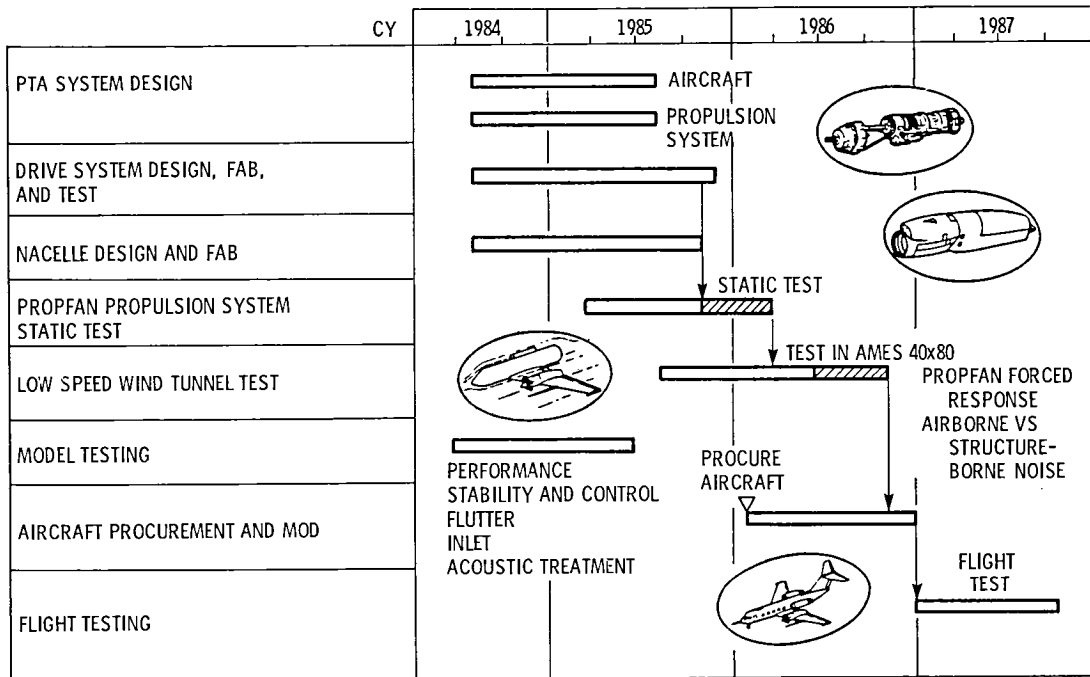
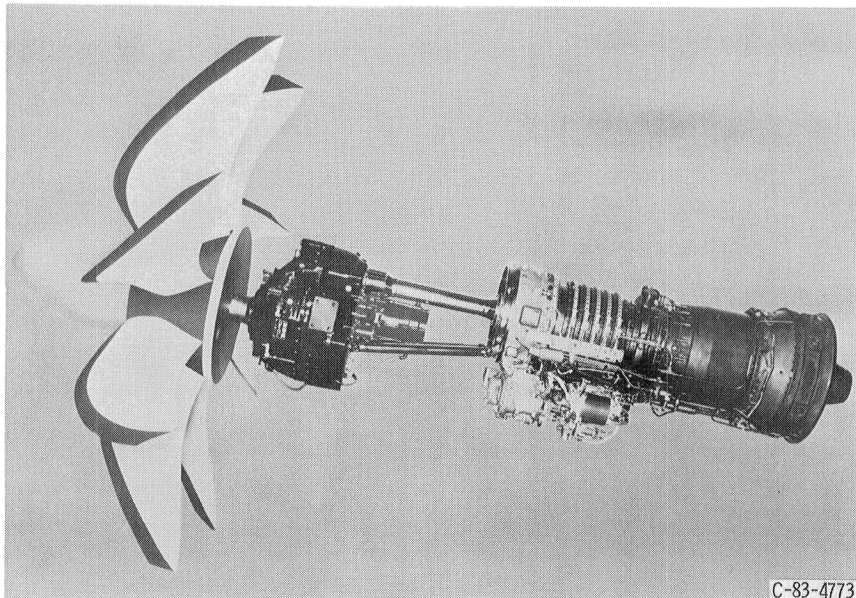

Figure 30. - Propfan Test Assessment (PTA) program.



C-83-4773

Figure 31. - SR-7L propfan and Allison drive system.



C-84-1936

Figure 32. - Gulfstream II, with profan, to be used for flight tests during the Propfan Test Assessment (PTA) program.

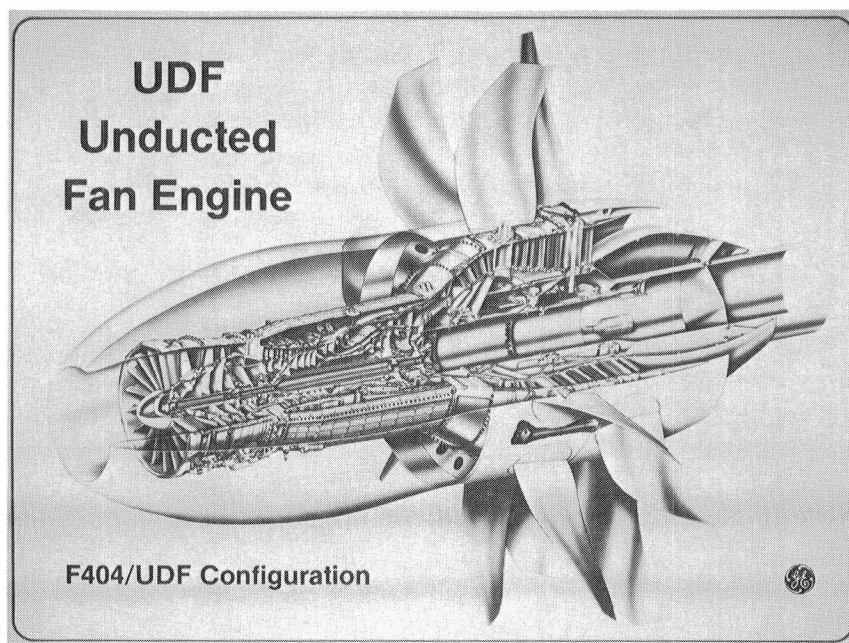

Figure 33. - Unducted fan engine (UDF).





1. Report No. NASA TM-83736		2. Government Accession No.		3. Recipient's Catalog No.	
4. Title and Subtitle  Fuel Savings Potential of the NASA Advanced Turboprop Program				5. Report Date	
				6. Performing Organization Code 535-03-12	
7. Author(s)  J. B. Whitlow, Jr. and G. K. Sievers				8. Performing Organization Report No. E-2218	
				10. Work Unit No.	
9. Performing Organization Name and Address National Aeronautics and Space Administration Lewis Research Center Cleveland, Ohio 44135				11. Contract or Grant No.	
				13. Type of Report and Period Covered Technical Memorandum	
12. Sponsoring Agency Name and Address National Aeronautics and Space Administration Washington, D.C. 20546				14. Sponsoring Agency Code	
15. Supplementary Notes  Prepared for the Aviation Fuel Conservation Symposium sponsored by the Federal Aviation Administration, Washington, D.C., September 10-11, 1984.					
16. Abstract  The NASA Advanced Turboprop (ATP) Program is directed at developing new technology for highly-loaded, multi-bladed propellers for use at Mach 0.65 to 0.85 and at altitudes compatible with the air transport system requirements. Advanced turboprop engines offer the potential of 15 to 30 percent savings in aircraft block fuel relative to <u>advanced</u> turbofan engines (50 to 60 percent savings over today's turbofan fleet). The concept, propulsive efficiency gains, block fuel savings and other benefits, and the program objectives through a systems approach are described. Current program status and major accomplishments in both single-rotation and counter-rotation propeller technology are addressed. The overall program from scale model wind tunnel tests to large-scale flight tests on testbed aircraft is discussed.					
17. Key Words (Suggested by Author(s))  Turboprop Propeller Commercial aircraft Fuel conservation			18. Distribution Statement  Unclassified - unlimited STAR Category 07		
19. Security Classif. (of this report) Unclassified		20. Security Classif. (of this page) Unclassified		21. No. of pages	22. Price*





National Aeronautics and  
Space Administration

Washington, D.C.  
20546

Official Business  
Penalty for Private Use, \$300

SPECIAL FOURTH CLASS MAIL  
BOOK



3 1176 00512 7288



Postage and Fees Paid  
National Aeronautics and  
Space Administration  
NASA-451

**NASA**

DO NOT REMOVE SLIP FROM MATERIAL	
Delete your name from this slip when returning material to the library.	
NAME	MS
J. Lan	269

If Undeliverable (Section 158  
Postal Manual) Do Not Return

NASA Langley (Rev. May 1988)

RIAD N-75