

SPECIAL TEST METHODS FOR BATTERIES

Sidney Gross
Boeing Aerospace Company
Seattle, Washington 98124

A variety of methods has been used for determining heat generation in primary and secondary batteries (References 1 - 3). One method useful for sealed primary batteries is to insulate the battery with multilayer vacuum insulation, discharge it in a vacuum, and observe its temperature change with time (Figure 1). Six layers of aluminized mylar separated by low outgassing bridal-veil type material has proved to be effective, resulting in nearly negligible heat loss. Heat transfer through supports is made insignificant by suspending the battery with nylon string. Heat transport through supports, leads and insulation is small, but calibration is advisable nevertheless. The heat generation rate is then:

$$dQ/dt = W C_p (dT/dt) + A \quad \text{EQN (1)}$$

where Q is heat generated, W is battery mass, C_p is specific heat, T is temperature, t is time, and A is the calibration factor. This method was applied to a sealed silver-zinc battery.

Where a thermal vacuum chamber is not available or is impracticable, alternative methods can be used for measuring heat generation. One method is to insulate the battery and make a correction for the heat transport through the insulation. A convenient way to make the correction is to test with different thicknesses of insulation, and extrapolate results to the condition of zero heat loss. A preferred way to make the correction is the analytical method described in Reference 1. Typical results using that method are shown in Figure 2, with heat generation correlated on the basis of enthalpy voltage. With this method, the heat generation rate is equal to cell current times the difference of enthalpy voltage and cell voltage.

Heat generation measurement of large batteries presents special problems. A method used successfully was to attach an insulated battery to a water-cooled coldplate suitably instrumented to function as a calorimeter. The battery heat generated is the sum of the heat transported to the fluid plus the heat stored within the battery, plus or minus heat transported through the insulation (Figure 3). High flow rates through the cold plate are preferred to minimize temperature gradients, but this results in a small temperature rise of the fluid through the cold plate. To obtain accuracy in spite of having only a small temperature rise, a sensitive instrumentation system is used which measures temperature difference directly (Figure 4). Calibration curves of this sensor are shown in Figure 5. Insulation of the battery should be done in a way that is repeatable and permits calibration. A conformally shaped insulation box with fiberglass surfaces inside and outside served these needs. Calibration with a battery and heat exchanger installed and electrical cables attached resulted in overall conductance in ambient air of 0.2 W/°F at a battery temperature of 50°F, increasing linearly to 0.4 W/°F at a battery temperature of 180°F.

Specific heat of batteries (Figure 6) can be determined in a way similar to heat generation, provided a heater is attached to the battery (Figure 7); in the case of a sealed secondary battery, steady state overcharge can be used in lieu of a heater. Thermal vacuum testing gives the least error; an alternative is to encapsulate the battery with a heater in waterproof insulation and immerse it in a water bath for the test. A method used satisfactorily is to precool the battery below the water

temperature, and allow the experiment to continue until the battery is hotter than the water bath (Figure 7). Specific heat is determined using equation 1, with minimum heat correction at the isothermal point.

A common method for cooling spacecraft cells is by sandwiching the cells between cooling plates, thus removing heat from the broad faces of the cells. This raises the need for determining cell thermal conductance in that direction. One method that has been used is to sandwich a cell between two thick plates whose thermal conductivity is known and is also close to that of the cell; heat is then forced through the assembly by means of two heat exchangers (Figure 8), with insulation around the assembly to minimize error. Plexiglas Type 2 has suitable properties for this test and has been used satisfactorily. Cell thermal conductance can be determined by comparison of the temperature gradient across the cell with the gradient across the plexiglas of known thickness; the use of two layers of plexiglas permits an assessment of the error.

Thermal vacuum tests have been found to be very useful in determining thermal conductance within batteries. The batteries are insulated around all sides except the bottom, which radiates to an adjacent temperature-controlled plate. Steady state overcharge at high rates will exaggerate the temperature gradient and provide data needed to determine conductance. A test that is especially useful is to lower the temperature of the plate heat sink with time in a programmed manner so the battery temperature will reduce linearly with time. This induces temperature gradients between the cells and the battery case which are constant with time (Figure 9). This test has been used to identify poor thermal bonding between cells and the case of a battery package.

Measurements have been taken of the temperature gradient in nickel cadmium cells during cycling for possible use in charge control. This is based on the principle that charge efficiency decreases as a nickel cadmium cell approaches a full state of charge, resulting in a sudden increase in the heat generation rate within the cell. Since spacecraft batteries are generally mounted so there is a good thermal path between the cell bottom and the heat sink, this heating results in temperature gradients across the cell. The temperature difference may be taken between the cell top and cell bottom, between the cell top and the heat sink, or between the cell bottom and the heat sink. Heat flux transducers are an alternative approach. For a simulated 24-hour orbit, the temperature difference signal starts to rise at a recharge fraction of approximately 0.95 (Figure 10). The tests showed that temperature gradient sensing can provide an effective means of charge control for 24-hour orbit satellites. However, the method is not suitable for low-earth orbits since the heat generated during discharge has insufficient time to dissipate before charging commences.

Auxilliary electrodes can be useful for conducting tests on battery charge control. For the Ni-Cd system, an oxygen-sensitive electrode coupled to the negative electrode through a resistor provides a signal which gives a measure, though nonlinear, of oxygen partial pressure. This has been applied to compare pulse charging and constant current charging.

A variety of battery-level tests has been used to characterize nickel cadmium cells. Such tests can be conducted on cells at the beginning of a cycling test, then repeated at intervals to quantize the degradation. A discharge sweep with current increasing linearly with time has been used; similar tests have also been done with two-second discharge pulses with current increasing at each pulse. This quickly distinguishes the resistance-limited regime from the diffusion-limited regime. Current-sweep tests have also been done for charge, with current increasing linearly with time.

Another battery test which has proved useful is a linear sweep of current from charge to discharge. The crossing point where current is zero is identified as the zero-current voltage. It is related to the open circuit voltage, except that it eliminates the problem of a continuously varying open circuit voltage that is associated with batteries having nickel electrodes. The other advantage is that it is a measurement that sometimes can be obtained from telemetry of flight spacecraft. This has proven useful in identifying incipient shorting during flight operation of Ni-Cd batteries.

Definition of fast transient behavior of batteries in the microsecond range has been of interest for some applications. Silver zinc batteries, for example, exhibit a brief discharge voltage dip following open circuit with Ag_2O_2 present (Figure 11). Visicorders are not fast enough to define some of these transients. A transient voltage monitor system is used which takes data every 200 nanoseconds. The signal is processed by an analogue-to-digital converter and stored in memory. Following the test, the memory is fed repetitively to an oscilloscope through a digital to analogue unit for immediate viewing, and also transferred to magnetic tape for computer processing and point-by-point data printout.

A number of tests have been conducted on cell components. One unique test is the determination of the electrical conductance of nickel sinters in the thickness direction. This is considered important because corrosion and mechanical stress from cycling will reduce conductance significantly. A die was used to cut 15/16 inch diameter discs of electrodes or electrode sinters, indium foil, and copper. These are assembled into a stack: copper, indium, sinter, indium, copper (Figure 12). Sometimes multiple indium-sinter sandwiches are used in series. The stack is compressed to obtain good contact of the indium foil and the sinter, yet not crush them. The electrical conductance of the stack is measured, and an adjustment is made for the calibration of the stack without the sinter.

Mechanical problems have been experienced in the vibration of nickel-cadmium batteries (Reference 4). Tests to simulate the cycling fatigue of the steel tabs connecting the plates to the comb showed that a wide variation could be expected in the fatigue life of these tables. Nickel cadmium cells must be under some compression when packaged for spacecraft use, but surprisingly little is known about the visco-elastic behavior of cells under such conditions. An analytical model of a cell under compression is shown in Figure 13. One series of tests defined the distribution of forces when cells are compressed during battery packaging. These tests showed that there was a significant relaxation of compressive forces on the plates with time.

References

1. S. Gross, "Heat Generation in Sealed Batteries", *Energy Conversion*, Vol. 9, pp. 55-62, 1969.
2. S. Gross and J. Malcolm, "Thermal Considerations in Sealed Nickel Cadmium Cells", in *Power Sources 4*, Proceedings of 8th International Symposium, September 1972, D. H. Collins, Ed., pp. 257-275, Oriel Press (1973).
3. S. Gross, Development and Fabrication of Advanced Battery Energy Storage System, Contract NAS9-6470, Final Report, Oct. 1967.
4. S. Gross, "Designing for Vibration with Sealed Nickel Cadmium Cells", The 1976 Goddard Space Flight Center Battery Workshop, Nov. 1976, Report X-711-77-28.

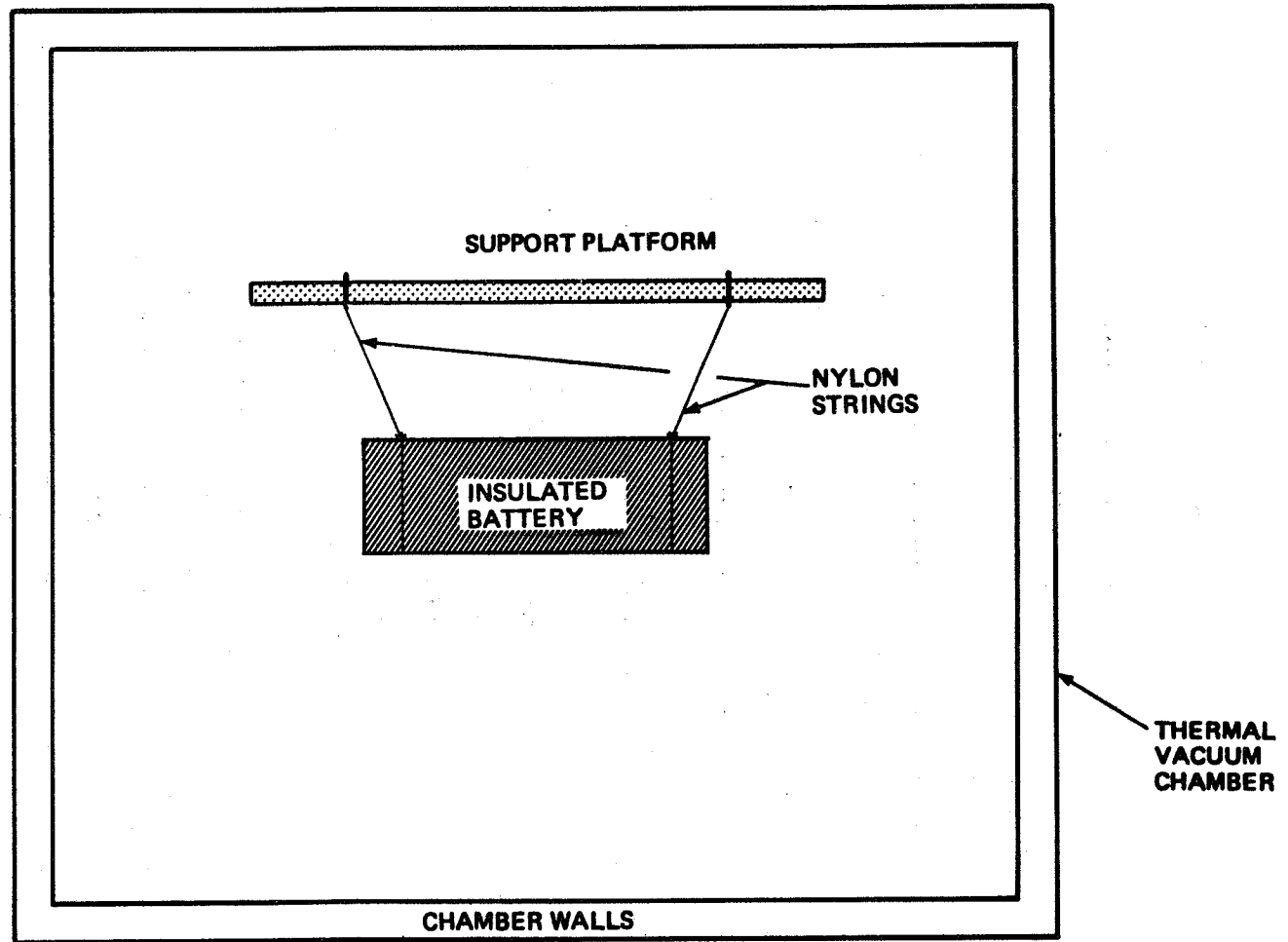

Figure 1. Thermal Vacuum Chamber Installation for Measurement of Battery Heat Generation

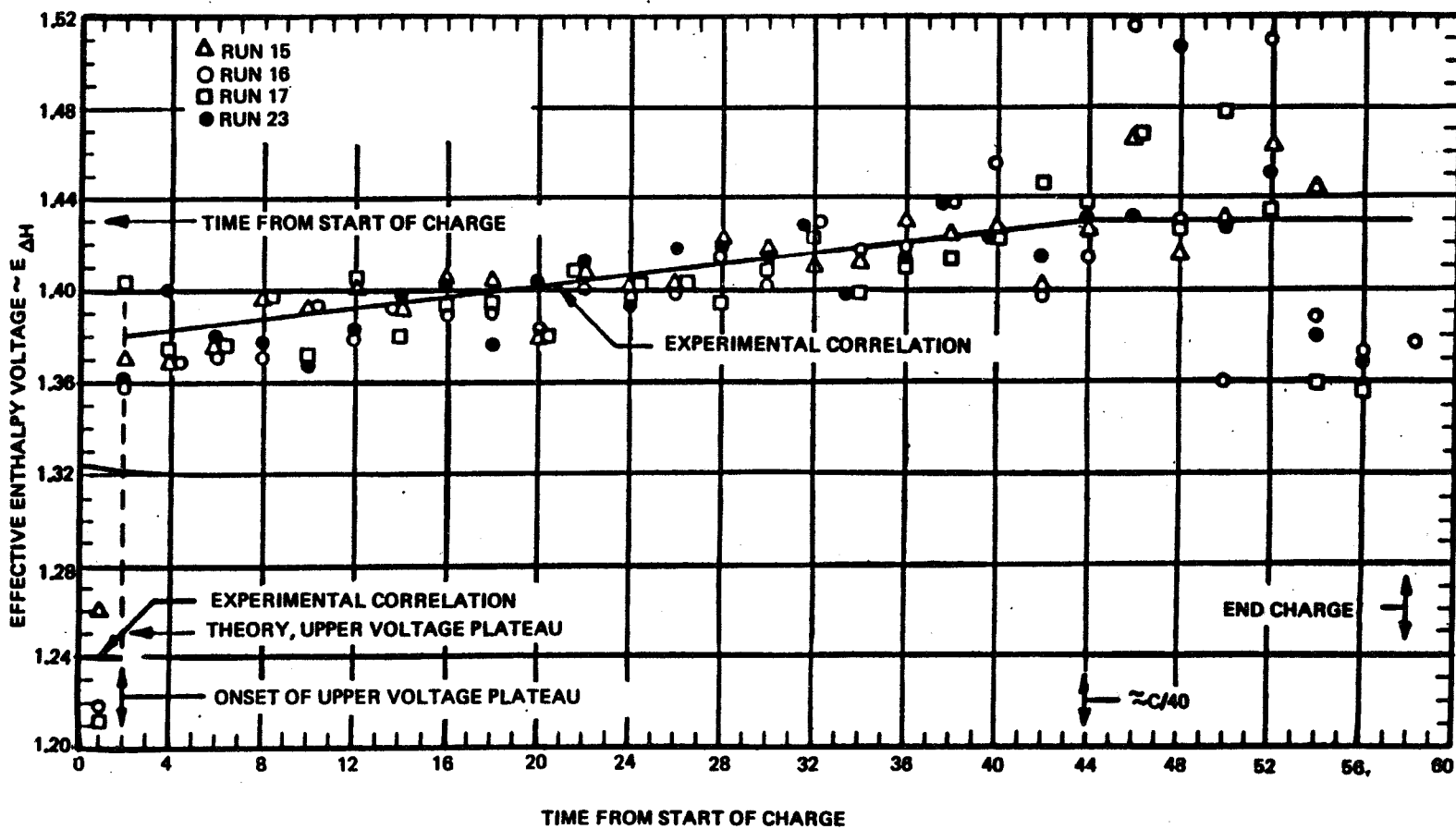
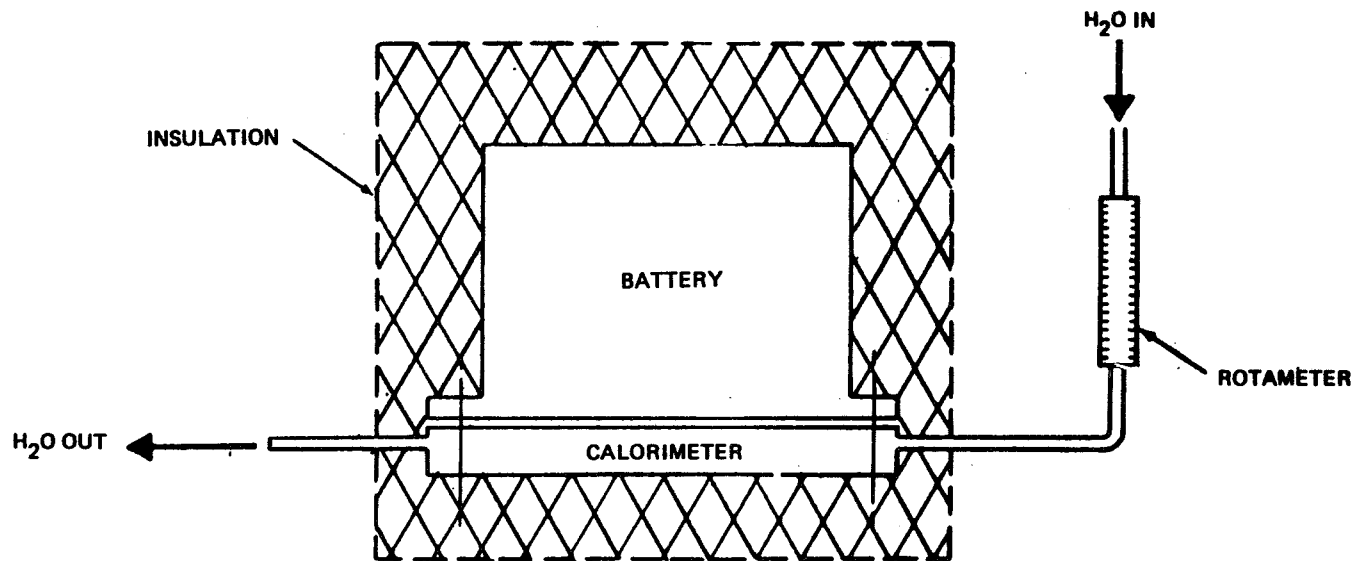

Figure 2. Correlation of Heat Generation Enthalpy Voltage During Charge of Silver-Cadmium Cells



$$\boxed{\text{HEAT GENERATED}} = \boxed{\text{HEAT TO FLUID}} + \boxed{\text{HEAT STORED}} + \boxed{\text{HEAT LOST}}$$

MEASUREMENTS

1. BATTERY TEMP ——— THERMOCOUPLES
2. FLOW RATE ——— ROTAMETER
3. FLOW ΔT ——— THERMOPILE OR THERMISTORS

Figure 3. Battery Calorimeter Concept

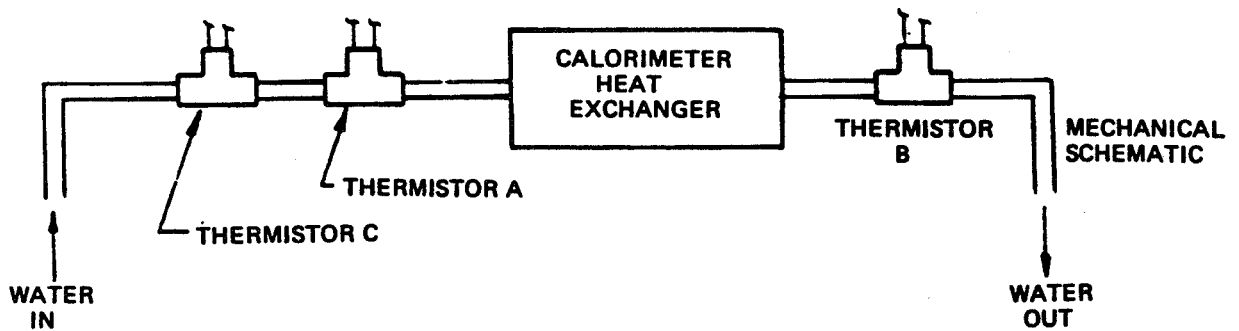
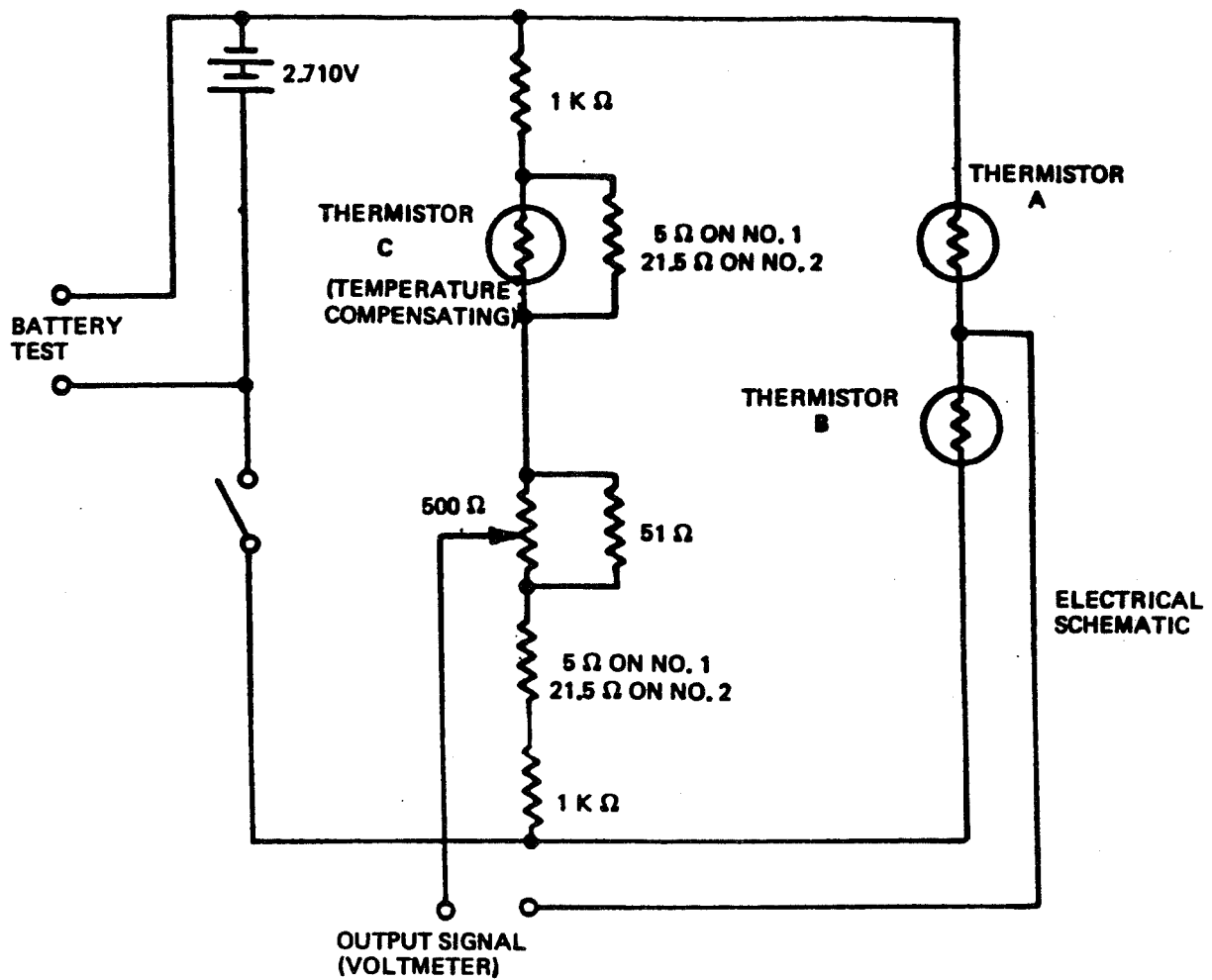

Figure 4. Schematic of Calorimeter Temperature Difference Sensor

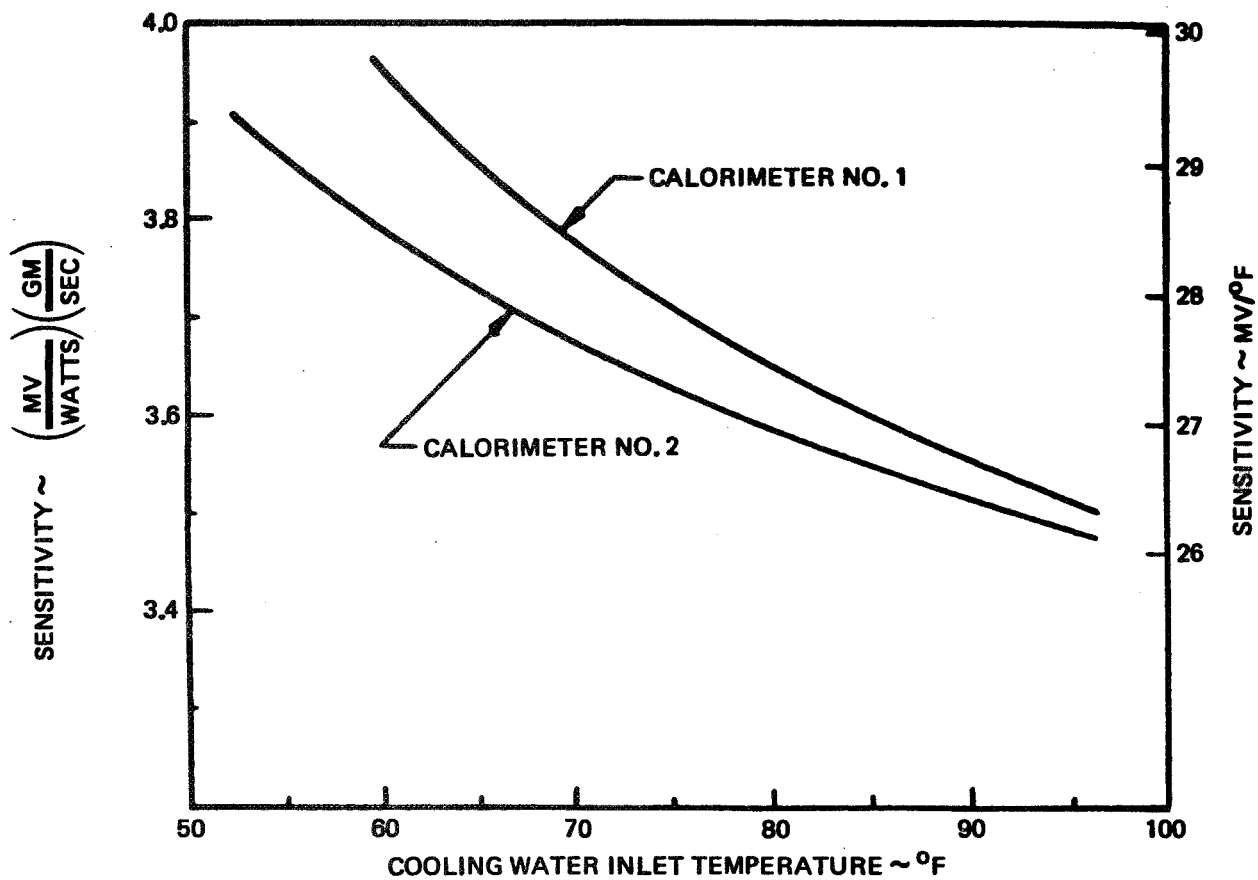

Figure 5. Sensitivity Curve—Calorimeter Temperature Difference Sensor

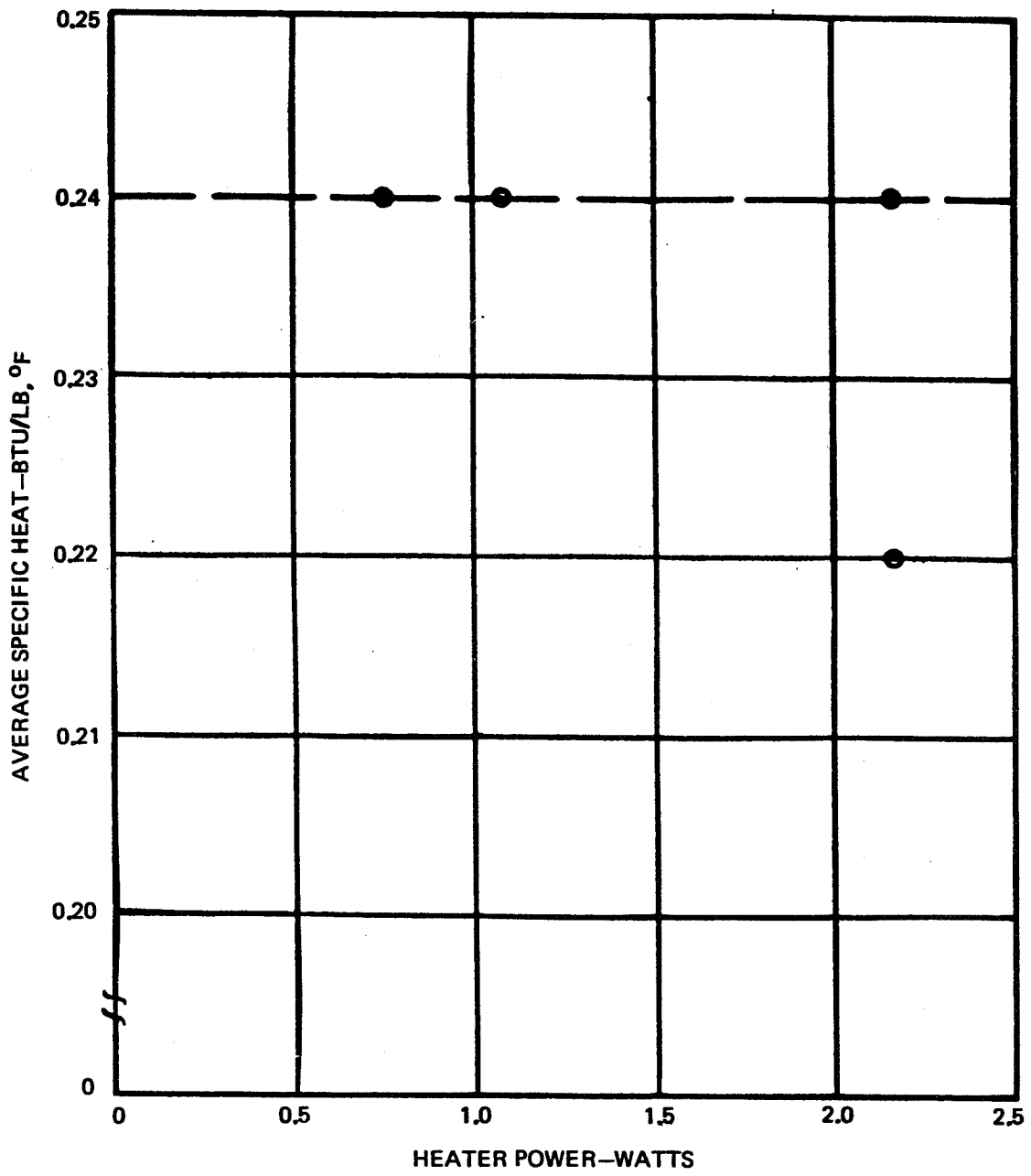
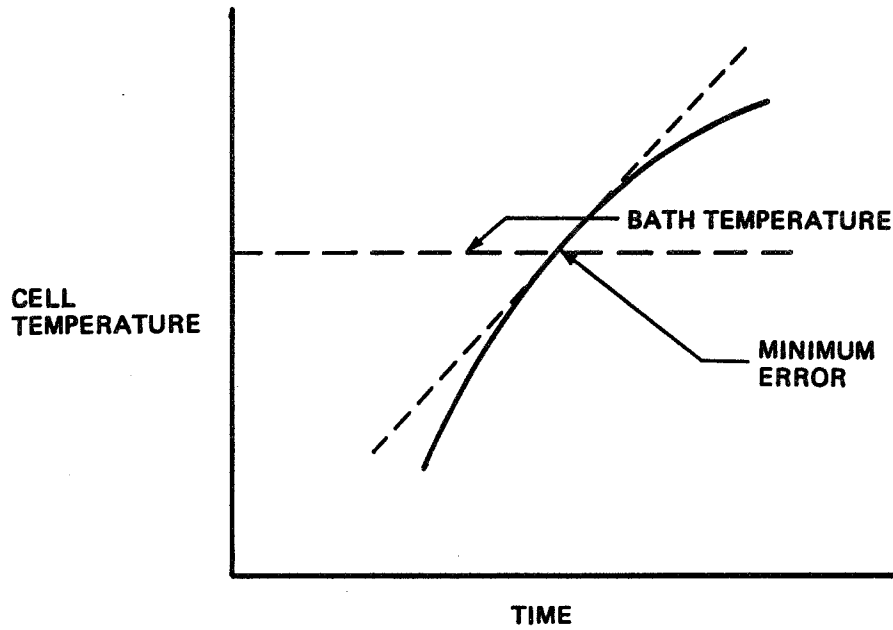
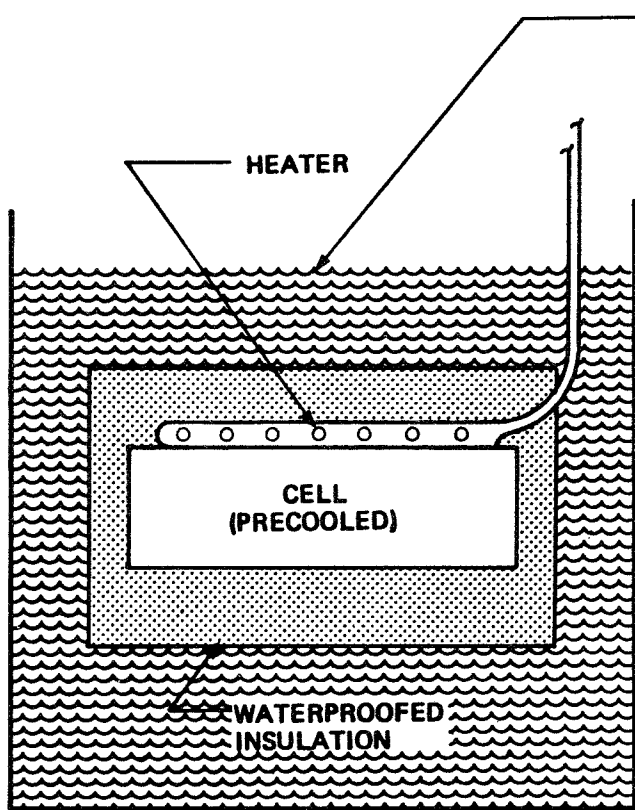

Figure 6. Specific Heat Test of 70 AH Silver Cadmium Cell

410



$$\frac{dQ}{dt} = W C_p \frac{dT}{dt}$$

↑
CALCULATE FROM DATA

Figure 7. Cell Specific Heat Test

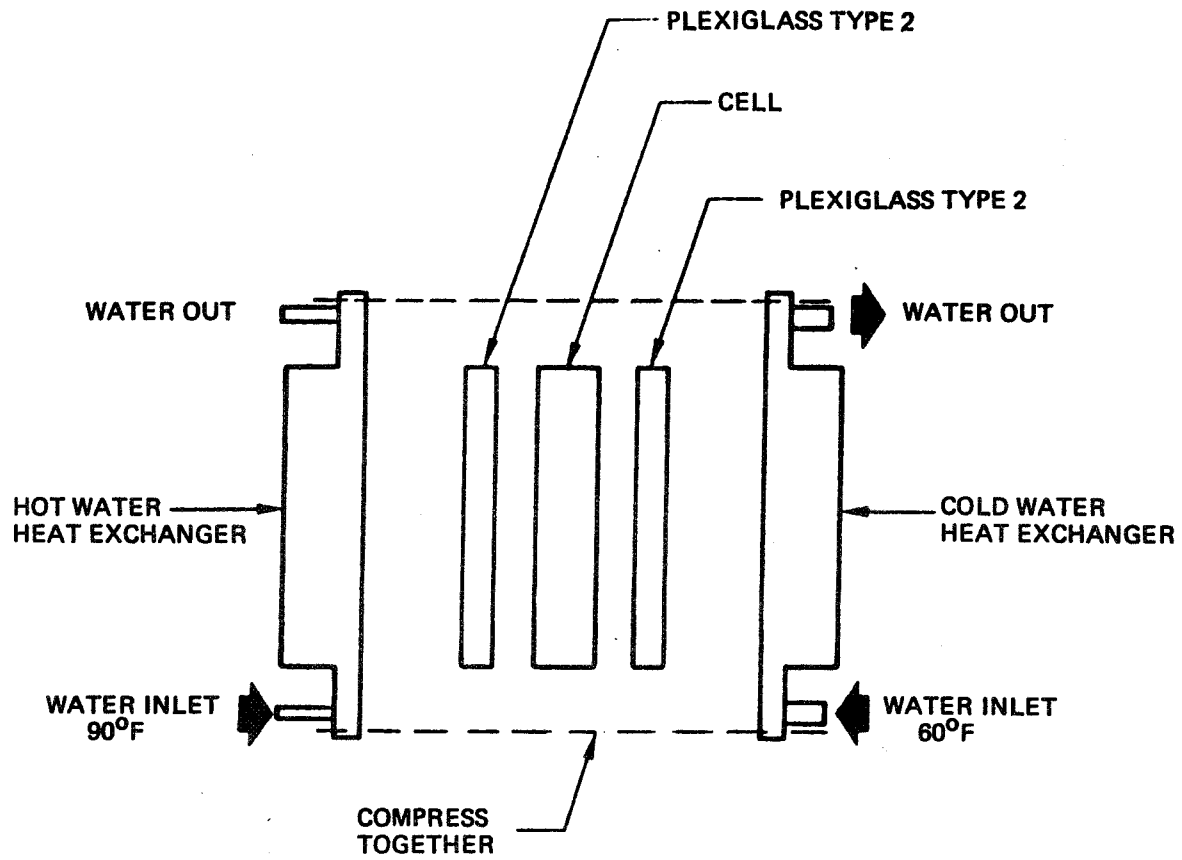

Figure 8. Cell Thermal Conductivity Test

412

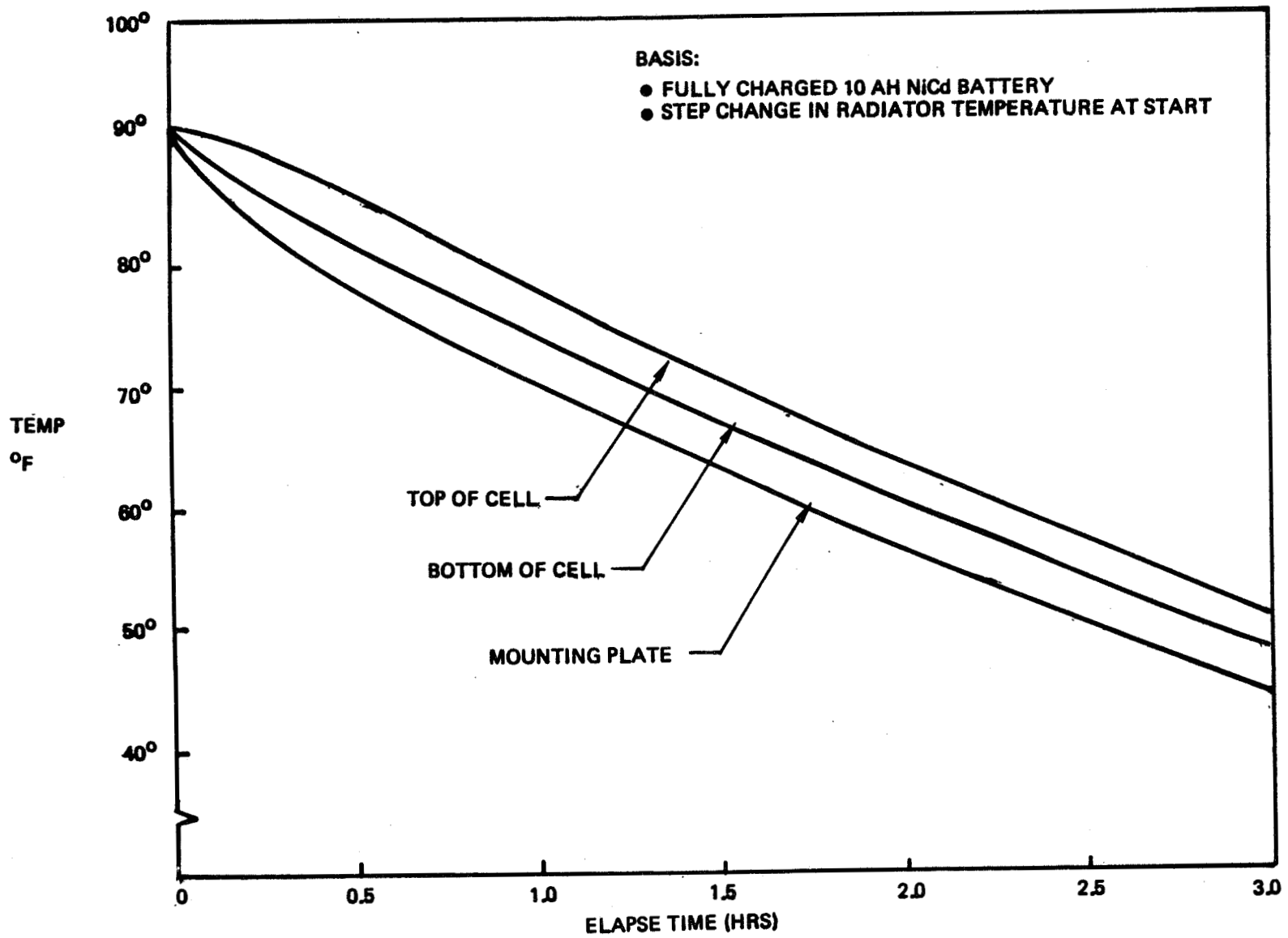

Figure 9. Radiant Cooling Vacuum Test of 10 AH Ni-Cd Battery

- SIMULATED 24-HR ORBIT
- 12 AH SEALED Ni-Cd CELL
- DISCHARGE 1.0 HR AT 8.0 A (67% DoD)
- CHARGE AT 3.0 A (C/4)
- TEMPERATURE DIFFERENCE MEASURED AT CELL MOUNTING
- COMMENCE CHARGE WHEN $\Delta T < 0.5^{\circ}\text{F}$

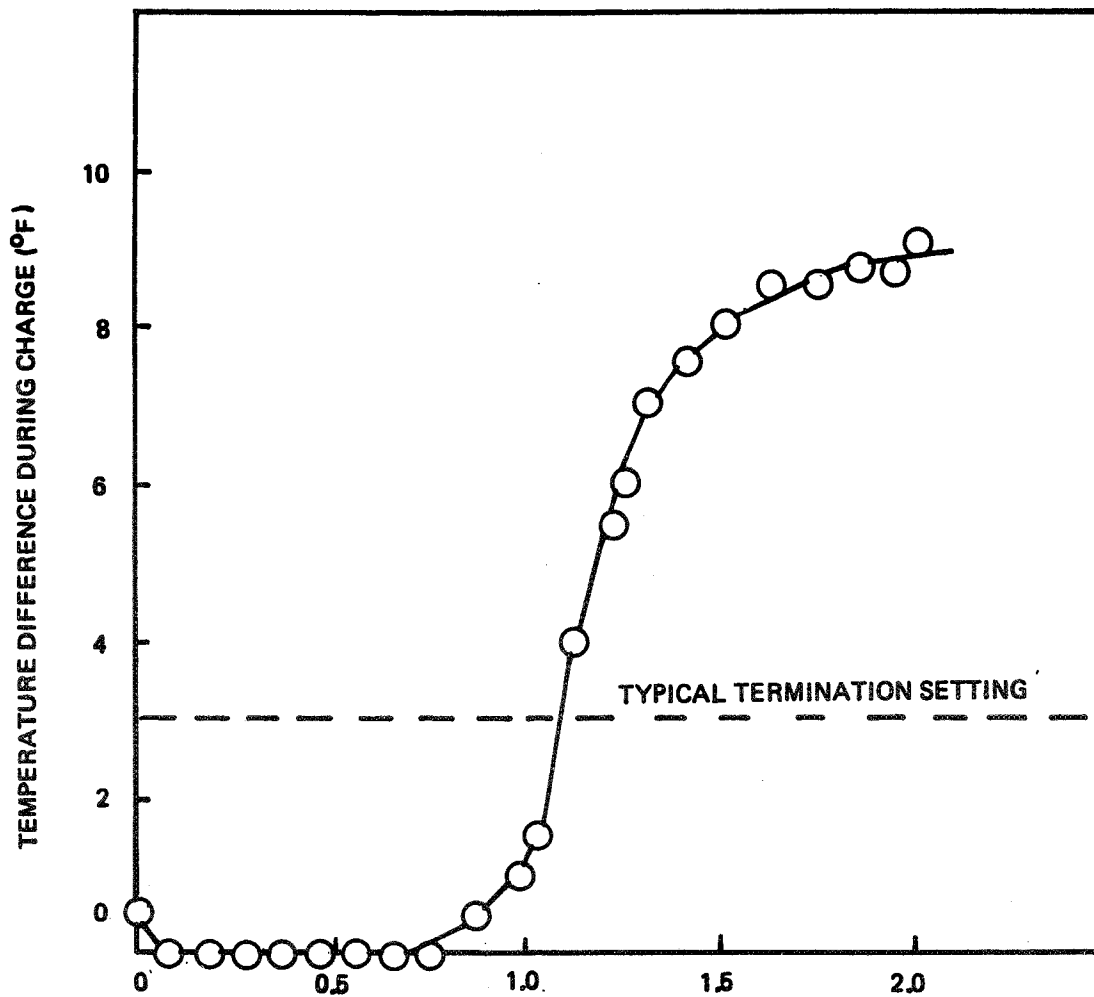

Figure 10. Sensitivity of Temperature Difference Sensing for Charge Termination

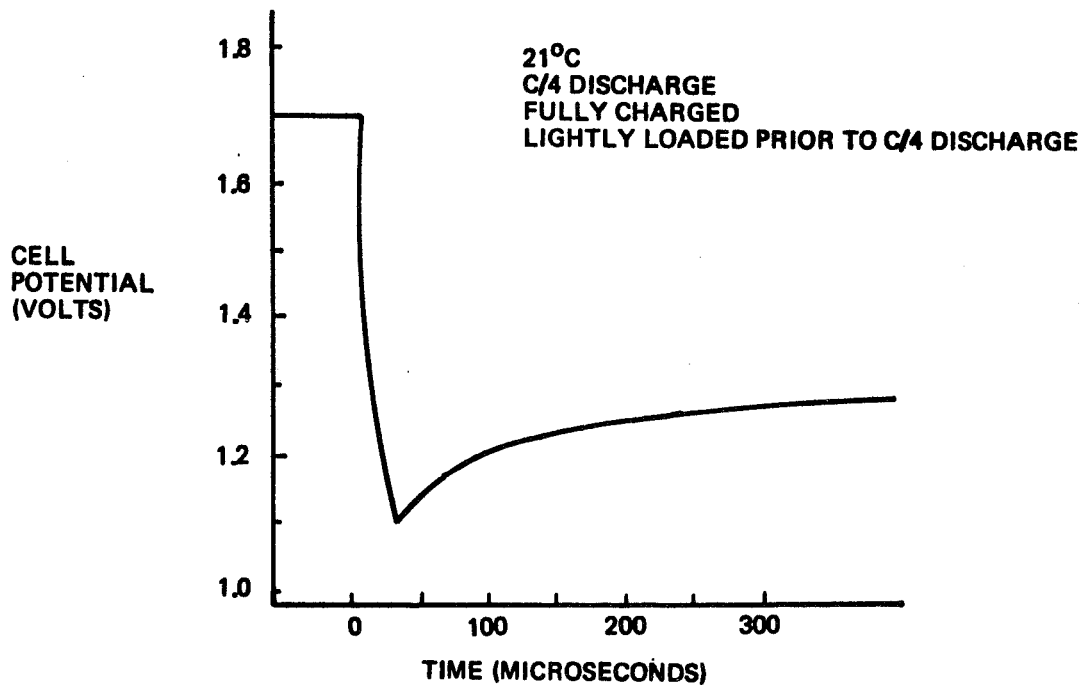
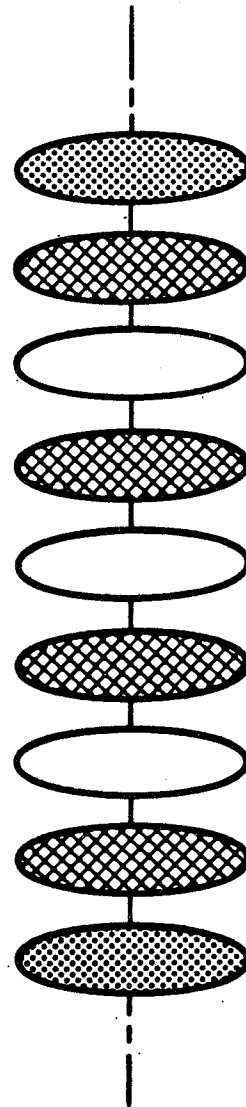

Figure 11. Typical Voltage Delay Behavior of Silver-Zinc Cells

- DISCS 15/16 INCH DIAMETER
- MEASURE STACK RESISTANCE UNDER COMPRESSION





	COPPER
	INDIUM FOIL
	PLAQUE

Figure 12. Test for Electrical Resistance of Plaque in Thickness Direction

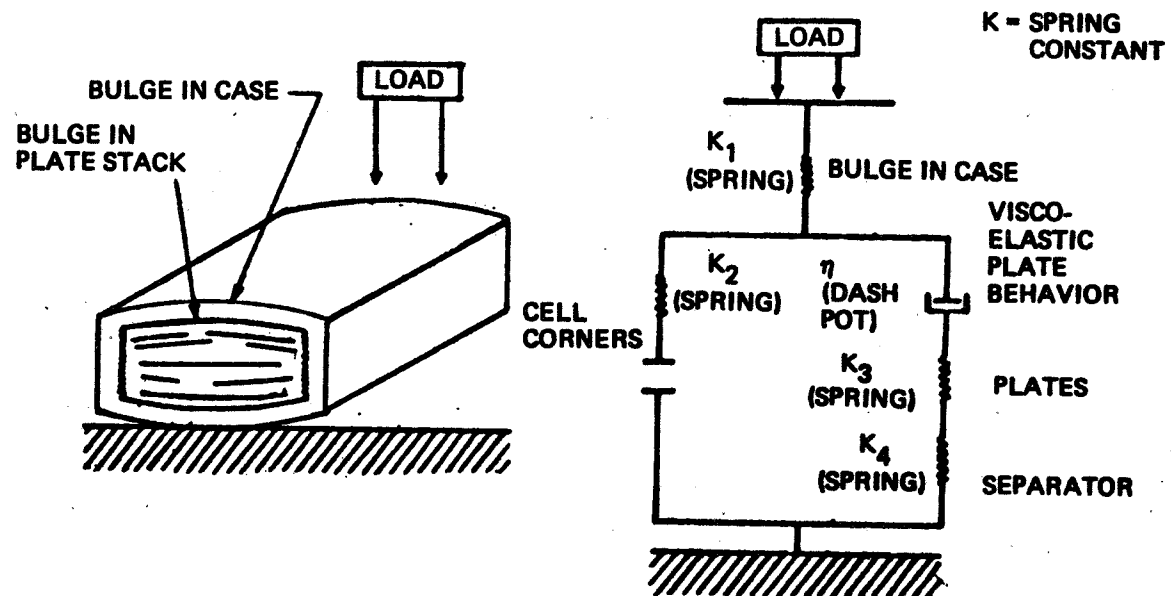

Figure 13. Analytical Model of Cell in Compression

- Q. Mani, Energy Conversion Devices, Inc.: What kind of equipment did you use for this heat capacity measurement? What type of heat capacity you measure by this method?
- A. Gross, Boeing: What kind of heat capacity does one measure by?
- Q. Mani, Energy Conversion Devices, Inc.: This kind of heat capacity. The one where you are , I mean showed in the figure?
- A. Gross, Boeing: Okay, well the data shown for the example was heat capacity of 0.2 and which is the same in let's see that the same in engineering units that BTU's per pound per degree fahrenheit.
- Q. Mani, Energy Conversion Devices, Inc.: You said the heat capacity you measure is. Don't you think it is distributed more in the alkaline. And how you can differentiate you are going to measure one as a total but the cell capacity mostly differs upon the electrode and the alkaline interface. How are you going to differentiate this one?
- A. Gross, Boeing: Well, this is a net heat capacitance cell and if you know exactly what the percentage is of each material that goes into the cell and the specific heat of those materials you can calculate the average heat capacitance but we didn't have, we weren't competent that we had good data and that was the reason we wanted to run the test.
- A. Mani, Energy Conversion Devices, Inc.: Thank you.
- Q. Unidentified, Eastman Kodak: Your plaque resistance test. Was that a DC or a AC test?
- A. Gross, Boeing: That was a DC test.
- Q. Unidentified, Eastman Kodak: Was it pressure sensitive or was it temperature sensitive?
- A. Gross, Boeing: We tested the affects of pressure and we found that very low pressure gave us unreproducible results and very high pressure also gave us results where we would squeeze down too much and would give us we felt, we were compressing the materials too much and we found in between was an exceptable range where we got reproducible results and yet we didn't feel as if we were injuring any of the parts.

- Q. LaFrance, Aerospace Corp.: I found the techniques are interesting. I would like to ask you more of a question about the results however. For example, essentially the charging you mentioned was in endothermic region you reached about 80% charge, then it becomes essentially exothermic. Now is this true at a charge rate of C over 10 or C over two or something like that during the endothermic region.
- A. Gross, Boeing: Well that data was for nickel cadmium cell and nickel cadmium cell is endothermic during charge except that in for large cells or even small cells that height charge rates the endothermic amount is frequently offset by our eye drop due to the charge current so frequently when you actually measure a cell you will get very close to zero. It's been our experiences it's very close to zero as a result of the two cancelling out and then of course the point at which the heat generation starts is dependent upon the temperature and the charge rate. So you really can't generalize to say exactly what the shape of the heat as a function at the end of charge.
- Q. Unidentified, Aerospace Corp.: Sid, what is the purpose of the foil and the thickness resistance measurement.
- A. Gross, Boeing: The purpose of the foil is to get electrical contact to the plaque material otherwise you can't easily make an electrical contact over its entire surface.