

General Disclaimer

One or more of the Following Statements may affect this Document

- This document has been reproduced from the best copy furnished by the organizational source. It is being released in the interest of making available as much information as possible.
- This document may contain data, which exceeds the sheet parameters. It was furnished in this condition by the organizational source and is the best copy available.
- This document may contain tone-on-tone or color graphs, charts and/or pictures, which have been reproduced in black and white.
- This document is paginated as submitted by the original source.
- Portions of this document are not fully legible due to the historical nature of some of the material. However, it is the best reproduction available from the original submission.

Model Equation for Simulating Flows in Multistage Turbomachinery

(NASA-TM-86869) MODEL EQUATION FOR
SIMULATING FLOWS IN MULTISTAGE
TURBOMACHINERY (NASA) 37 p HC A03/MF A01

N85-12036

CSSL 01A

Unclas

G3/02 24437

John F. Adamczyk
Lewis Research Center
Cleveland, Ohio

November 1984



NASA

MODEL EQUATION FOR SIMULATING FLOWS IN MULTISTAGE TURBOMACHINERY

John J. Adamczyk
National Aeronautics and Space Administration
Lewis Research Center
Cleveland, Ohio 44135

SUMMARY

A steady, three-dimensional average-passage equation system is derived for use in simulating multistage turbomachinery flows. These equations describe a steady, viscous flow that is periodic from blade passage to blade passage. From this system of equations, various reduced forms can be derived for use in simulating the three-dimensional flow field within multistage machinery. It is suggested that a properly scaled form of the average-passage equation system would provide an improved mathematical model for simulating the flow in multistage machines at design and, in particular, at off-design conditions.

INTRODUCTION

The flow field in multistage compressors and turbines is extremely complex. This flow field is highly unsteady, with time scales ranging from a fraction of shaft speed to several times that of the highest blade passing frequency. The length scales of the flow are also diverse. They range from the circumference of the machine to a fraction of a blade chord. The vast range of time and length scales makes direct numerical simulation practically impossible. Confronted with analyzing complex, multiple-scale problems, aerodynamicists have traditionally described their physics in terms of an appropriately averaged set of equations. A prime example of this methodology is the Reynolds-averaged modeling of turbulent flows. For turbomachinery the literature seems to support a description based on an average blade passage. With respect to a given blade row the flow within the average passage is steady and spatially periodic from blade passage to blade passage.

In the present work a rigorous attempt is made to derive the equations governing this flow field. To the author's knowledge, this three-dimensional equation system has not been defined. It can be reduced to the familiar combined through-flow (meridional), blade-to-blade (cascade) equation set (ref. 1) by introducing a number of assumptions, all of which appear to be justified for highly efficient machines operating near design. Further, they can be reduced to the through-flow equations derived by Sehra (ref. 2) by assuming the flow to be inviscid, by assuming that heat is added reversibly, and by employing a tangential averaging operator. More importantly, the derived equation set provides a reference against which multistage analyses can be judged for their completeness. In particular, given the advances being made in the field of computational fluid dynamics, it might be time to determine if any of the assumptions that restrict the validity of today's multistage analyses to the neighborhood of the design point can be removed. Of these assumptions those that are consistent with a quasi-three-dimensional flow structure need to be carefully reevaluated. If these assumptions can be removed without yielding an equation system that is essentially unsolvable on second-generation class VI

computers, the resulting equation system should enhance our ability to simulate the flow in multistage turbomachines.

Three averaging operators are developed for application to the Navier-Stokes equations in the next section of this report. The first averaging operator, referred to as "ensemble averaging," is introduced to eliminate the need to resolve, in detail, the structure of turbulent flows. The application of this operator to the Navier-Stokes equations yields the Reynolds-averaged form of these equations. This equation set describes an unsteady deterministic flow field. The global effects of turbulence on this flow field are accounted for by means of a Reynolds stress and a scalar flux tensor.

The second operator to be developed is a time-averaging operator. This operator is used to average the deterministic unsteady equations in time at every point in space. This operation removes unsteady time scales that are of the order of the period of shaft rotation or less. The global effect of the coherent (as opposed to random) blade-to-blade unsteady flow structure manifests itself in the resulting equation system as body forces, energy sources, momentum, and energy temporal mixing correlations. The effect of these terms on the axisymmetric flow field generated by an isolated rotor was investigated by Sehra (ref. 2). For a single-stage machine subjected to an axisymmetric inlet and exit condition, the resulting equations describe the three-dimensional average-passage flow field associated with either the rotor or stator blade row. For multistage machines the equation set governs, in general, a flow field that varies from passage to passage around a given blade row.

For the average-passage equations to be extracted from this equation system, they must be averaged on a passage-to-passage basis. The third averaging operator that is developed accomplishes this task. This operator averages out the details of the passage-to-passage variation in the flow field. However, the global effect of this variation on the average-passage flow field is not eliminated. Its existence is accounted for through body forces, energy sources, momentum, and energy spatial mixing correlations.

The average-passage flow equations are derived in the third section of this report. These equations contain correlations that arise from turbulence, unsteady coherent flow, and passage-to-passage flow variations. These correlations are generic to this equation system, as the Reynolds stress tensor is generic to the Reynolds-averaged Navier-Stokes equations. They serve as the mechanism by which the passage-average flow field is energized in a multistage environment. The need to account for this mixing process in turbomachinery flow analyses was recently documented in reference 3.

Two reduced forms of the average-passage flow equations are developed in the final section of this report. In deriving the first set of equations it is assumed that the body forces and energy sources generated by the presence of neighboring blade rows can be evaluated in a through-flow blade-to-blade analysis (ref. 4). It is further assumed that the mixing correlations can be modeled in both the through-flow blade-to-blade analysis and the average-passage system according to the analysis presented in reference 3. The resulting set of equations describes a three-dimensional flow field whose axisymmetric component is equal to that predicted by the through-flow blade-to-blade model. In the second approach an average-passage equation system is developed for each blade row in the machine. The resulting system of equations is coupled through

common expressions for the mixing correlations, the body forces, and the energy sources. Thus the equations must be solved simultaneously. The closure problem associated with this formulation requires the development of models that globally describe the mixing produced by the coherent spatial and temporal non-uniform flow, in addition to models for the Reynolds stress and associated turbulent correlations.

AVERAGING PROCEDURE

Ensemble-Averaging Procedure

To derive the average-passage equation system for turbomachinery flows, three averaging operators must be applied consecutively to the Navier-Stokes equations. The first operator, often referred to in the literature on turbulence as "ensemble averaging" (ref. 5), serves to decouple the unsteady deterministic flow features from the random fluctuations. This averaging procedure yields the familiar Reynolds-averaged Navier-Stokes equation. Its mathematical form is defined as

$$\bar{f} = \lim_{N \rightarrow \infty} \frac{1}{N} \sum_{i=1}^N f_i \quad (1)$$

where f_i denotes the i^{th} realization of the variable f and N denotes the total number of observations of this variable. That is, if N experiments are conducted, each experiment produces a realization (i.e., an observation) of a physical variable at a given point in space at a given instant in time. The average value of this variable is estimated by evaluating the sum of the realization divided by the number of experiments. It is assumed that the quotient becomes independent of the number of experiments as the number of experiments becomes large.

For the analysis of a compressible turbulent flow it has proven useful to define a density-weighted ensemble average (ref. 6). The form of this averaging operator is

$$\bar{f} = \lim_{N \rightarrow \infty} \frac{1}{\rho N} \sum_{i=1}^N \rho_i f_i \quad (2)$$

where ρ is the ensemble average density and ρ_i is the i^{th} realization of the density field. The velocity field as well as the fluid total properties is generally defined in terms of this weighted average. Finally note that this averaging operator commutes with differentiation; that is,

$$\overline{\frac{\partial f}{\partial x}} = \frac{\partial \bar{f}}{\partial x} \quad (3)$$

where x is an appropriate independent variable. This property is often taken for granted in deriving the Reynolds-averaged Navier-Stokes equations.

Time-Averaging Procedure

The second averaging operator yields the time-averaged flow equations. This operator is applied throughout the flow domain, including the region within the rotating blade rows. Several researchers have used a time-averaging operator to develop the steady flow equations for the flow field downstream of a rotating blade row (ref. 7). In the current analysis the range of applicability of this operator is extended to include the flow region within blade rows (i.e., stationary and rotating). The traditional definition of this averaging operator is given by the integral

$$\bar{f} = \frac{1}{T} \int_{t_1}^{t_1+T} f dt \quad (4)$$

where T is the period of one rotor revolution, t_1 is the reference starting time, and f the deterministic component of f . To extend this averaging procedure to the flow region within the rotating blade rows, a "gate function" must first be defined for each rotating blade row. This function is represented by a finite number of step functions. Its value is 1 for any point within the flow domain and zero in the regions occupied by the blades. The mathematical form of this function for a blade row with N blades is

$$H(t) = U(t - t_{ref}) + \sum_{n=0}^{K_p(N-1)} U \left[t - t_{ref} - \left(\theta_1 + \theta_2 + \frac{2\pi n}{N} - \theta \right) \frac{1}{\Omega} \right] \\ - \sum_{n=0}^{K_p(N-1)} U \left[t - t_{ref} - \left(\theta_1 + \theta_1 + \frac{2\pi n}{N} - \theta \right) \frac{1}{\Omega} \right] \quad (5)$$

where U is the unit step function, Ω is the rotational speed of the shaft, K_p is the number of shaft revolutions over which H is defined, and t_{ref} is the reference starting time. The remaining variables in this equation are defined in figure 1. The length of time during one revolution of the shaft for which this function is nonzero is

$$T_B = \frac{2\pi}{\Omega} + \frac{(\theta_1 - \theta_2)N}{\Omega} \quad (6)$$

where $(\theta_2 - \theta_1)$ defines the local blade thickness. The ratio of this length of time to the period of revolution ($T = 2\pi/\Omega$) is a measure of the blockage due to the blading (ref. 1). We define for future use a weighting function λ_B that is equal to

$$\lambda_R = 1 + \frac{(\theta_1 - \theta_2)N}{2\pi} \quad (7)$$

(i.e., 1 minus the blockage) within a rotor blade passage and 1 outside a passage.

A time-averaging operator that is applicable to all regions of space can be defined as

$$\bar{f} = \frac{\Omega}{2\pi\lambda_R} \int_{t_1}^{t_1 + \frac{2\pi}{\Omega}} H(t) \bar{f}(t) dt \quad (8)$$

Outside a rotor passage this operator reduces to equation (4), since λ_R and H become equal to 1. Under these circumstances it can be shown that the time-averaging operator commutes with differentiation. However, within a rotor passage this property is lost.

A formula that specifies the rules governing the order of spatial differentiation and time averaging at every point in space is needed in the next section. This formula will be developed for the r partial derivative $\partial/\partial r$. The formulas for the partial derivatives with respect to either θ or Z can be developed in a similar fashion. Begin by directly substituting $d\bar{f}/dr$ into equation (8) to get

$$\overline{\frac{\partial f}{\partial r}} = \frac{\Omega}{2\pi\lambda_R} \int_{t_1}^{t_1 + \frac{2\pi}{\Omega}} H \frac{\partial \bar{f}}{\partial r} dt \quad (9)$$

This expression can be rewritten as

$$\overline{\frac{\partial f}{\partial r}} = \frac{\partial}{\partial r} \left[\frac{\Omega}{2\pi\lambda_R} \int_{t_1}^{t_1 + \frac{2\pi}{\Omega}} H \bar{f} dt \right] + \frac{1}{\lambda_R} \frac{\partial \lambda_R}{\partial r} \left[\frac{\Omega}{2\pi\lambda_R} \int_{t_1}^{t_1 + \frac{2\pi}{\Omega}} H \bar{f} dt \right] - \frac{\Omega}{2\pi\lambda_R} \int_{t_1}^{t_1 + \frac{2\pi}{\Omega}} \bar{f} \frac{\partial H}{\partial r} dt \quad (10)$$

since the limits of integration are independent of r . The two identical integrals in equation (10) are equal to \bar{f} . The remaining integral can be evaluated by noting that

$$\frac{\partial H}{\partial r} = \frac{1}{\Omega} \sum_{n=0}^{K_p(N-1)} \left\{ \delta \left[t - t_{\text{ref}} - \left(\theta_1 - \theta_1 + \frac{2\pi n}{N} - \theta \right) \frac{1}{\Omega} \right] \frac{\partial \theta_1}{\partial r} - \delta \left[t - t_{\text{ref}} - \left(\theta_1 - \theta_2 + \frac{2\pi n}{N} - \theta \right) \frac{1}{\Omega} \right] \frac{\partial \theta_2}{\partial r} \right\} \quad (11)$$

where δ is Dirac delta function (ref. 8). Introducing this expression into the last integral in equation (10) yields

$$\begin{aligned} \frac{\Omega}{2\pi\lambda_R} \int_{t_1}^{t_1 + \frac{2\pi}{\Omega}} \bar{f} \frac{\partial H}{\partial r} dt \\ = \frac{N}{2\pi\lambda_R} \left(\frac{1}{N} \sum_{n=0}^{N-1} \left\{ \bar{f} \left[r, \theta, z, t_{\text{ref}} + \left(\theta_1 + \theta_1 + \frac{2\pi(n+l)}{N} - \theta \right) \frac{1}{\Omega} \right] \frac{\partial \theta_1}{\partial r} - \bar{f} \left[r, \theta, z, t_{\text{ref}} + \left(\theta_1 + \theta_2 + \frac{2\pi(n+l)}{N} - \theta \right) \frac{1}{\Omega} \right] \frac{\partial \theta_2}{\partial r} \right\} \right) \end{aligned} \quad (12)$$

where l is an integer. Equation (10) can be rewritten as

$$\begin{aligned} \frac{\partial \bar{f}}{\partial r} = \frac{1}{\lambda_R} \frac{\partial(\lambda_R \bar{f})}{\partial r} + \frac{N}{2\pi\lambda_R} \left(\frac{1}{N} \sum_{n=0}^{N-1} \left\{ \bar{f} \left[r, \theta, z, t_{\text{ref}} + \left(\theta_1 + \theta_1 + \frac{2\pi(n+l)}{N} - \theta \right) \frac{1}{\Omega} \right] \frac{\partial \theta_1}{\partial r} - \bar{f} \left[r, \theta, z, t_{\text{ref}} + \left(\theta_1 + \theta_2 + \frac{2\pi(n+l)}{N} - \theta \right) \frac{1}{\Omega} \right] \frac{\partial \theta_2}{\partial r} \right\} \right) \end{aligned} \quad (13)$$

This equation is the formula for interchanging time averaging and differentiation with respect to r . It is valid at every point in space. A similar result can be derived for interchanging differentiation with respect to either θ or z and time averaging. A formula for interchanging time averaging and the temporal derivative will also be needed in the next section. To derive this formula, substitute $\partial \bar{f} / \partial t$ into equation (8) to get

$$\frac{\partial \bar{f}}{\partial t} = \frac{\Omega}{2\pi\lambda_R} \int_{t_1}^{t_1 + \frac{2\pi}{\Omega}} \frac{\partial \bar{f}}{\partial t} H dt \quad (14)$$

This expression can be integrated by parts to yield

$$\overline{\frac{\partial f}{\partial t}} = \frac{\Omega}{2\pi\lambda_R} \left[\bar{f}H \Big|_{t_1 + \frac{2\pi}{\Omega}} - \bar{f}H \Big|_{t_1} \right] - \frac{\Omega}{2\pi\lambda_R} \int_{t_1}^{t_1 + \frac{2\pi}{\Omega}} \bar{f} \frac{\partial H}{\partial t} dt \quad (15)$$

According to the Leibnitz rule (ref. 9), the quantity within brackets can be rewritten as

$$\frac{\Omega}{2\pi\lambda_R} \left[\bar{f}H \Big|_{t_1 + \frac{2\pi}{\Omega}} - \bar{f}H \Big|_{t_1} \right] = \frac{\partial}{\partial t_1} \frac{\Omega}{2\pi\lambda_R} \int_{t_1}^{t_1 + \frac{2\pi}{\Omega}} \bar{f}H dt = \frac{\partial \bar{f}}{\partial t_1} \quad (16)$$

The integral in equation (15) can be evaluated once the expression

$$\frac{\partial H}{\partial t} = \delta(t - t_{ref}) + \sum_{n=0}^{K_p(N-1)} \left\{ \delta \left[t - t_{ref} - \left(\theta_2 + \theta_1 + \frac{2\pi(n+1)}{N} - \theta \right) \frac{1}{\Omega} \right] - \delta \left[t - t_{ref} - \left(\theta_1 + \theta_1 + \frac{2\pi(n+1)}{N} - \theta \right) \frac{1}{\Omega} \right] \right\} \quad (17)$$

is substituted for $\partial H/\partial t$. The final result is

$$\overline{\frac{\partial f}{\partial t}} = \frac{1}{\lambda_R} \frac{\partial \lambda_R \bar{f}}{\partial t_1} - \frac{\Omega N}{2\pi\lambda_R} \left\{ \frac{1}{N} \sum_{n=0}^{N-1} \left[f \left[r, \theta, z, t_{ref} + \left(\theta_2 + \theta_1 + \frac{2\pi(n+1)}{N} - \theta \right) \frac{1}{\Omega} \right] - f \left[r, \theta, z, t_{ref} + \left(\theta_1 + \theta_1 + \frac{2\pi(n+1)}{N} - \theta \right) \frac{1}{\Omega} \right] \right] \right\} \quad (18)$$

Note that outside a rotating blade passage the expression within brackets in equations (13) and (18) vanishes and that λ becomes equal to 1. Hence time averaging commutes with either temporal or spatial differentiation outside a rotating passage.

For a compressible fluid it will prove useful to define the velocity and total flow properties in terms of their density-weighted time average. This average is defined as

$$\bar{f} = \frac{\Omega}{2\pi\lambda_R \bar{\rho}} \int_{t_1}^{t_1 + \frac{2\pi}{\Omega}} H \bar{\rho} \bar{f} dt \quad (19)$$

which is analogous to the definition of the density-weighted ensemble average.

Passage-to-Passage Averaging Procedure

For a single-stage machine or a repeating-stage multistage machine subjected to axisymmetric inflow and outflow, the flow field described by the steady-flow equations will be periodic from blade passage to blade passage. Thus these equations, by definition, govern the average-passage flow field. However, for a multistage machine in which the number of blades varies from row to row, the steady flow will not, in general, be identical in each passage of a given row. For the average-passage flow equations for a general configuration to be developed, a third averaging operator must be introduced. This operator will be developed by means of the theory associated with Fourier analysis. This development is begun by defining a gate function for each stator blade row. (Observe that the analysis being developed is for the absolute frame of reference.) This function, like the preceding one (i.e., eq. (5)) is defined in terms of a finite number of unit step functions. For a stator blade (rotor for the relative frame of reference) row with L blades this function is equal to

$$G(\theta) = 1 - \sum_{l=0}^{L-1} U \left[\theta - \left(\alpha + \theta_3 + \frac{2\pi l}{L} \right) \right] + \sum_{l=0}^{L-1} U \left[\theta - \left(\alpha + \theta_4 + \frac{2\pi l}{L} \right) \right] \quad (20)$$

The variables α , θ_3 , and θ_4 are defined in figure 2. The ratio of the angular distance for which G is nonzero to the angular distance around the machine (i.e., 2π) is a measure of the blockage attributed to the blade row. This ratio is equal to

$$B_S = 1 + \frac{(\theta_3 + \theta_4)L}{2\pi} \quad (21)$$

The gate function G is used in the construction of a Fourier series representation in θ of the flow variable \bar{f} . This representation is given by the equation

$$G(\theta)\bar{f}(\theta) = \sum_{n=-\infty}^{\infty} A_n e^{in\theta} \quad (22)$$

where the Fourier coefficients A_n are defined as

$$A_n = \frac{1}{2\pi} \int_0^{2\pi} G\bar{f} e^{-in\theta} d\theta \quad (23)$$

The passage-to-passage average of \bar{f} is defined with respect to a referenced stator (rotor) blade row. For a blade row with M blades this average is defined as

$$\bar{\bar{f}} = \frac{1}{\lambda_S} \sum_{k=-\infty}^{\infty} A_{kM} e^{ikM\theta} \quad (24)$$

where A_{kM} is the kM Fourier coefficient and the weighting function λ_S is set equal to 1 outside a stator passage and for all stators having multiples of M blades. For the remaining stators λ_S is given by equation (21). By construction, f is periodic over a distance of $\theta = 2\pi/M$. Introducing the integral representation for A_{kM} (i.e., eq. (23) into eq. (24)) yields

$$\bar{f} = \frac{1}{2\pi\lambda_S} \sum_{k=-\infty}^{\infty} \int_0^{2\pi} G \bar{f} e^{ikM(\theta-\tilde{\theta})} d\tilde{\theta} \quad (25)$$

Interchanging the order of summation and integration in this equation and noting that the infinite series can be expressed as (ref. 8)

$$\sum_{k=-\infty}^{\infty} e^{ikM(\theta-\tilde{\theta})} = \frac{2\pi}{M} \sum_{m=-\infty}^{\infty} \delta\left(\theta - \tilde{\theta} - \frac{2\pi m}{M}\right) \quad (26)$$

yield

$$\bar{f} = \frac{1}{\lambda_S M} \int_0^{2\pi} \sum_{m=-\infty}^{\infty} \delta\left(\theta - \tilde{\theta} - \frac{2\pi m}{M}\right) G \bar{f} d\tilde{\theta} \quad (27)$$

The order of integration and summation is reversed to simplify this result. The integral that appears under the summation sign can then be evaluated. The final form of the expression for \bar{f} becomes

$$\bar{f} = \frac{1}{\lambda_S M} \sum_{m=0}^{M-1} G\left(r, \theta + \frac{2\pi m}{M}, z\right) \bar{f}\left(r, \theta + \frac{2\pi m}{M}, z, t_1\right) \quad (28)$$

Equation (28) states that the passage-to-passage average of a variable is equal to the arithmetic mean of the value of the variable at the corresponding relative position within a blade row times the blockage factor $1/\lambda_S M$. Thus the passage-to-passage average of a variable will in general be different for each blade row. It will, however, be periodic in θ , the period being set by the geometry of the referenced blade row.

In the next section the passage-to-passage averaging operator is used to transform the steady-flow equations into their passage-to-passage averaged form. Before carrying out this exercise, it is necessary to establish the rules governing interchanging passage-to-passage averaging and spatial differentiation. This rule is developed here for the r partial derivative. The rule for the remaining spatial derivatives (i.e., θ and z) can be developed accordingly. Equation (25) states that the passage-to-passage average of $\partial f/\partial r$ with respect to a blade row with M blades is

$$\overline{\frac{\partial f}{\partial r}} = \frac{1}{2\pi\lambda_S} \sum_{k=-\infty}^{\infty} \int_0^{2\pi} G \frac{\partial f}{\partial r} e^{ikM(\theta-\tilde{\theta})} d\tilde{\theta} \quad (29)$$

Integrating this expression by parts yields

$$\begin{aligned} \frac{\partial \bar{f}}{\partial r} = \frac{\partial}{\partial r} & \left[\frac{1}{2\pi\lambda_S} \sum_{k=-\infty}^{\infty} \int_0^{2\pi} G \bar{f} e^{1kM(\theta-\tilde{\theta})} d\tilde{\theta} \right] \\ & + \frac{1}{\lambda_S} \frac{\partial \lambda_S}{\partial r} \left[\frac{1}{2\pi\lambda_S} \sum_{k=-\infty}^{\infty} \int_0^{2\pi} G \bar{f} e^{1kM(\theta-\tilde{\theta})} d\tilde{\theta} \right] \\ & - \frac{1}{2\pi\lambda_S} \sum_{k=-\infty}^{\infty} \int_0^{2\pi} \bar{f} \frac{\partial G}{\partial r} e^{1kM(\theta-\tilde{\theta})} d\tilde{\theta} \end{aligned} \quad (30)$$

The expression within brackets in equation (30) is equal to \bar{f} (refer to eq. (25)). To evaluate the integral that appears in the last term in equation (30), insert for $\partial G/\partial r$ the expression

$$\frac{\partial G}{\partial r} = \sum_{l=0}^{L-1} \left\{ \delta \left[\theta - \left(\alpha + \theta_3 + \frac{2\pi l}{L} \right) \right] \frac{\partial \theta_3}{\partial r} - \delta \left[\theta - \left(\alpha + \theta_4 + \frac{2\pi l}{L} \right) \right] \frac{\partial \theta_4}{\partial r} \right\} \quad (31)$$

Carrying out the integration yields

$$\begin{aligned} \frac{1}{2\pi\lambda_S} \sum_{k=-\infty}^{\infty} \int_0^{2\pi} \bar{f} \frac{\partial G}{\partial r} e^{1kM(\theta-\tilde{\theta})} d\tilde{\theta} \\ = \frac{1}{2\pi\lambda_S} \sum_{l=0}^{L-1} \sum_{k=-\infty}^{\infty} \left\{ \bar{f} \left(r, \alpha + \theta_3 + \frac{2\pi l}{L}, z, t_1 \right) \frac{\partial \theta_3}{\partial r} e^{1kM(\theta-\alpha-\theta_3-2\pi l/L)} \right. \\ \left. - \bar{f} \left(r, \alpha + \theta_4 + \frac{2\pi l}{L}, z, t_1 \right) \frac{\partial \theta_4}{\partial r} e^{1kM(\theta-\alpha-\theta_4-2\pi l/L)} \right\} \end{aligned} \quad (32)$$

This result can be rewritten as

$$\begin{aligned}
& \frac{L}{2\pi\lambda_S} \left\{ \frac{1}{L} \sum_{k=0}^{L-1} \left[\bar{f}\left(r, \alpha + \theta_3 + \frac{2\pi k}{L}, z, t_1\right) \frac{\partial \theta_3}{\partial r} - \bar{f}\left(r, \alpha + \theta_4 + \frac{2\pi k}{L}, z, t_1\right) \frac{\partial \theta_4}{\partial r} \right] \right\} \\
& + \frac{1}{\pi\lambda_S} \sum_{k=0}^{L-1} \bar{f}\left(r, \alpha + \theta_3 + \frac{2\pi k}{L}, z, t_1\right) \frac{\partial \theta_3}{\partial r} \sum_{k=1}^{\infty} \cos kM \left(\theta - \alpha - \theta_3 - \frac{2\pi k}{L} \right) \\
& - \frac{1}{\pi\lambda_S} \sum_{k=0}^{L-1} \bar{f}\left(r, \alpha + \theta_4 + \frac{2\pi k}{L}, z, t_1\right) \frac{\partial \theta_4}{\partial r} \sum_{k=1}^{\infty} \cos kM \left(\theta - \alpha - \theta_4 - \frac{2\pi k}{L} \right) \quad (33)
\end{aligned}$$

The first term in this expression represents the axisymmetric contribution; the remaining two terms represent the nonaxisymmetric contribution. Introducing this result along with equation (25) into equation (30) yields

$$\begin{aligned}
\frac{\partial \bar{f}}{\partial r} &= \frac{1}{\lambda_S} \frac{\partial}{\partial r} \lambda_S \bar{f} \\
& - \frac{L}{2\pi\lambda_S} \left\{ \frac{1}{L} \sum_{k=0}^{L-1} \bar{f}\left(r, \alpha + \theta_3 + \frac{2\pi k}{L}, z, t_1\right) \frac{\partial \theta_3}{\partial r} - \bar{f}\left(r, \alpha + \theta_4 + \frac{2\pi k}{L}, z, t_1\right) \frac{\partial \theta_4}{\partial r} \right\} \\
& - \frac{1}{\pi\lambda_S} \sum_{k=0}^{L-1} \bar{f}\left(r, \alpha + \theta_3 + \frac{2\pi k}{L}, z, t_1\right) \frac{\partial \theta_3}{\partial r} \sum_{k=1}^{\infty} \cos kM \left(\theta - \alpha - \theta_3 - \frac{2\pi k}{L} \right) \\
& + \frac{1}{\pi\lambda_S} \sum_{k=0}^{L-1} \bar{f}\left(r, \alpha + \theta_4 + \frac{2\pi k}{L}, z, t_1\right) \frac{\partial \theta_4}{\partial r} \sum_{k=1}^{\infty} \cos kM \left(\theta - \alpha - \theta_4 - \frac{2\pi k}{L} \right) \quad (34)
\end{aligned}$$

This equation represents the formula for interchanging the order of passage-to-passage averaging and partial differentiation with respect to r . Similar expressions can be developed for the θ and z partial derivatives. The partial derivative with respect to t_1 can be shown to commute with the passage-to-passage averaging operator.

For a compressible fluid it is advantageous to define the velocity field and total flow variables in terms of a density-weighted average. The density-weighted form of the passage-to-passage averaging operator is defined as

$$\bar{f} \approx \frac{1}{\lambda_S M \bar{\rho}} \sum_{m=0}^{M-1} G\left(r, \theta + \frac{2\pi m}{M}, z\right) \bar{\rho} \bar{f} \quad (35)$$

This definition is in accordance with equation (19).

This completes the definition of all of the averaging operators needed to construct the average-passage equation system for a multistage machine. These definitions, along with the supporting analysis, are used in the next section.

PASSAGE-AVERAGED FLOW EQUATIONS

The equations describing the average-passage flow field are derived by sequentially applying the three averaging operators defined in the previous section to the Navier-Stokes equations. The continuity and tangential (i.e., θ) momentum equations associated with this flow field are derived here. The remaining two momentum equations (i.e., r and z direction) and the energy equation are given in the appendix.

To begin, the velocity field (defined in the absolute frame of reference) is decomposed into its density-weighted ensemble average component plus a random variable. The form of this decomposition for the radial velocity component V_r is

$$V_r = \tilde{V}_r + V_r' \quad (36)$$

where the superscript denotes the random component. A similar expression exists for the tangential velocity component V_θ and the axial velocity component V_z . The continuity equation expressed in terms of the cylindrical coordinates r , θ , and z is

$$\frac{\partial r\rho}{\partial t} + \frac{\partial}{\partial r} r\rho V_r + \frac{\partial}{\partial \theta} \rho V_\theta + \frac{\partial}{\partial z} r\rho V_z = 0 \quad (37)$$

Introducing the suggested velocity decomposition into equation (37) and multiplying the result by the ensemble-averaging operator produces

$$\frac{\partial r\bar{\rho}}{\partial t} + \frac{\partial}{\partial r} r\bar{\rho}\tilde{V}_r + \frac{\partial}{\partial \theta} \bar{\rho}\tilde{V}_\theta + \frac{\partial}{\partial z} r\bar{\rho}\tilde{V}_z = 0 \quad (38)$$

since the density-weighted ensemble average of the random velocity field is zero.

The next step entails decomposing the deterministic velocity field into its density-weighted, time-averaged component plus an unsteady component. For the radial component of velocity, this composition is of the form

$$\tilde{V}_r = \bar{\tilde{V}}_r + \hat{\tilde{V}}_r \quad (39)$$

where the superscript $\hat{}$ denotes the unsteady component. A similar decomposition will be introduced for the two remaining velocity components. Introducing equation (39) along with the corresponding expressions for the other velocity components into equation (38) yields, upon time averaging, the result

$$\frac{\partial r \lambda_R \bar{\rho}}{\partial t_1} + \frac{\partial r \lambda_R \bar{\rho} \tilde{V}_r}{\partial r} + \frac{\partial \lambda_R \bar{\rho} \tilde{V}_\theta}{\partial \theta} + \frac{\partial r \lambda_R \bar{\rho} \tilde{V}_z}{\partial z} = 0 \quad (40)$$

where λ_R is the weighting function associated with the blockage of the rotating blade rows (eq. (7)). In deriving equation (40) the rules for reversing the order of differentiation and time averaging as derived in the preceding section were used.

The final step entails decomposing the steady velocity field into a density-weighted, passage-to-passage averaged component and an aperiodic component. Decomposing the steady radial velocity component in this fashion yields

$$\tilde{V}_r = \bar{\tilde{V}}_r + \hat{\tilde{V}}_r \quad (41)$$

where the superscript $\hat{\tilde{}}$ denotes the aperiodic component. Introducing this decomposition for each velocity component into equation (40) and evaluating its passage-to-passage average with respect to the j^{th} stator yield

$$\frac{\partial r \lambda_j \bar{\rho}}{\partial t_1} + \frac{\partial r \lambda_j \bar{\rho} \bar{\tilde{V}}_r}{\partial r} + \frac{\partial \lambda_j \bar{\rho} \bar{\tilde{V}}_\theta}{\partial \theta} + \frac{\partial r \lambda_j \bar{\rho} \bar{\tilde{V}}_z}{\partial z} = 0 \quad (42)$$

where λ_j is a weighting function associated with the blockage of the neighboring blade rows. This function is equal to 1 outside a blade passage. Within a rotor or stator passage it is set equal to λ_R or λ_S , respectively. This equation follows directly from the material presented in the preceding section. Equation (42) represents the continuity equation for the average-passage flow field. Its mathematical structure is very similar to the continuity equation for the Navier-Stokes system.

The tangential momentum equation in the absolute frame of reference is

$$\begin{aligned} \frac{\partial \rho r V_\theta}{\partial t} + \frac{\partial}{\partial r} r \rho V_r V_\theta + \frac{\partial}{\partial \theta} \rho V_\theta V_\theta + \frac{\partial}{\partial z} r \rho V_z V_\theta + \rho V_r V_\theta \\ = - \frac{\partial p}{\partial \theta} + \frac{\partial}{\partial r} r \tau_{r\theta} + \frac{\partial}{\partial \theta} \tau_{\theta\theta} + \frac{\partial}{\partial z} r \tau_{z\theta} + \tau_{r\theta} \end{aligned} \quad (43)$$

where $\tau_{r\theta}$, $\tau_{\theta\theta}$, $\tau_{z\theta}$ are components of the viscous shear stress and p is the static pressure. The derivation of the passage-to-passage average form of this equation is begun by introducing the velocity decomposition, as defined by equation (36) for all three velocity components, into equation (43). Evaluating the ensemble average of the resulting expression yields the Reynolds-averaged form of the tangential momentum equation. This equation has the form (ref. 10).

$$\begin{aligned} \frac{\partial r \bar{\rho} \tilde{V}_\theta}{\partial t} + \frac{\partial}{\partial r} r \bar{\rho} \tilde{V}_r \tilde{V}_\theta + \frac{\partial}{\partial \theta} \bar{\rho} \tilde{V}_\theta \tilde{V}_\theta + \frac{\partial}{\partial z} r \bar{\rho} \tilde{V}_z \tilde{V}_\theta + \bar{\rho} \tilde{V}_r \tilde{V}_\theta = - \frac{\partial \bar{p}}{\partial \theta} + \frac{\partial}{\partial r} \left(r \bar{\tau}_{r\theta} - r \overline{\rho V_r' V_\theta'} \right) \\ + \frac{\partial}{\partial \theta} \left(\bar{\tau}_{\theta\theta} - \overline{\rho V_\theta' V_\theta'} \right) + \frac{\partial}{\partial z} r \bar{\tau}_{z\theta} - \overline{r \rho V_z' V_\theta'} + \bar{\tau}_{r\theta} - \overline{\rho V_r' V_\theta'} \end{aligned} \quad (44)$$

where the underscored terms represent three of the nine components of the Reynolds stress tensor. The time-averaged form of this equation is derived by first decomposing each velocity component according to equation (39). The resulting equation is then time averaged by using operator equation (6). The final expression is

$$\begin{aligned} \frac{\partial r}{\partial t_1} \lambda_R \bar{\rho} \tilde{V}_\theta + \frac{\partial}{\partial r} r \lambda_R \bar{\rho} \tilde{V}_r \tilde{V}_\theta + \frac{\partial}{\partial \theta} \lambda_R \left(\bar{\rho} \tilde{V}_\theta \tilde{V}_\theta + \bar{p} \right) + \frac{\partial}{\partial z} r \lambda_R \bar{\rho} \tilde{V}_z \tilde{V}_\theta + \lambda_R \bar{\rho} \tilde{V}_r \tilde{V}_\theta \\ = \frac{\partial}{\partial r} r \lambda_R \left(\bar{\tau}_{r\theta} - \overline{\bar{\rho} \hat{V}_r \hat{V}_\theta} - \overline{\rho V_r' V_\theta'} \right) + \frac{\partial}{\partial \theta} \lambda_R \left(\bar{\tau}_{\theta\theta} - \overline{\bar{\rho} \hat{V}_\theta \hat{V}_\theta} - \overline{\rho V_\theta' V_\theta'} \right) \\ + \frac{\partial}{\partial z} r \lambda_R \left(\bar{\tau}_{z\theta} - \overline{\bar{\rho} \hat{V}_z \hat{V}_\theta} - \overline{\rho V_z' V_\theta'} \right) + \lambda_R \left(\bar{\tau}_{r\theta} - \overline{\bar{\rho} \hat{V}_r \hat{V}_\theta} - \overline{\rho V_r' V_\theta'} \right) + F_{IN}^{(\theta R)} + F_V^{(\theta R)} \end{aligned} \quad (45)$$

The algebra that led to this result made use of the material presented in the preceding section and the velocity product averaging rule

$$\overline{\bar{\rho} \tilde{V}_r \tilde{V}_\theta} = \overline{\bar{\rho} (\tilde{V}_r + \hat{V}_r) (\tilde{V}_\theta + \hat{V}_\theta)} = \overline{\bar{\rho} \tilde{V}_r \tilde{V}_\theta} + \overline{\bar{\rho} \hat{V}_r \hat{V}_\theta}$$

(Similar expressions can be derived for the products $\overline{\bar{\rho} \tilde{V}_\theta \tilde{V}_\theta}$ and $\overline{\bar{\rho} \tilde{V}_z \tilde{V}_\theta}$.) The underscored terms in equation (45) represent the mixing stress attributed to the unsteady coherent velocity field. The body forces $F_{IN}^{(\theta R)}$ and $F_V^{(\theta R)}$ are associated with the inviscid and viscous forces acting on the rotating blades. The inviscid component F is equal to

$$F_{IN}^{(\theta R)} = \frac{N}{2\pi} \left\{ \frac{1}{N} \sum_{n=0}^{N-1} \left[\bar{p} \Big|_{t=t_{ref} + \left(\theta_1 + \theta_2 + \frac{2\pi(n+1)}{N} - \theta \right) \frac{1}{\Omega}} - \bar{p} \Big|_{t=t_{ref} + \left(\theta_1 + \theta_1 + \frac{2\pi(n+1)}{N} - \theta \right) \frac{1}{\Omega}} \right] \right\} \quad (46)$$

The corresponding expression for the viscous force is

$$F_V^{(\theta R)} = \frac{N}{2\pi} \left\{ \frac{1}{N} \sum_{n=0}^{N-1} \left[r \frac{\partial \theta_2}{\partial r} \bar{\tau}_{r\theta} - \bar{\tau}_{\theta\theta} + r \frac{\partial \theta_2}{\partial z} \bar{\tau}_{z\theta} \right] \Bigg|_{t=t_{ref} + \left(\theta_1 + \theta_2 + \frac{2\pi(n+1)}{N} - \theta \right) \frac{1}{\Omega}} \right. \\ \left. - \left[r \frac{\partial \theta_1}{\partial r} \bar{\tau}_{r\theta} - \bar{\tau}_{\theta\theta} + r \frac{\partial \theta_1}{\partial z} \bar{\tau}_{z\theta} \right] \Bigg|_{t=t_{ref} + \left(\theta_1 + \theta_1 + \frac{2\pi(n+1)}{N} - \theta \right) \frac{1}{\Omega}} \right\} \quad (47)$$

Both of these forces are axisymmetric and vanish outside a rotor passage.

For an isolated stage equation (47) is the tangential momentum equation of the average-passage equation system. For this limiting case the aerodynamic loading generated by the rotor produces an axisymmetric body force and an axisymmetric energy source, which are distributed over the axial extent of the rotor passage. The unsteady coherent velocity field generated by the rotor produces a stress that acts throughout the flow domain.

As was noted previously the time-averaged flow field within a multistage machine is not, in general, periodic from blade passage to blade passage. The steady tangential momentum equation, like the steady continuity equation, can be transformed into its average-passage form by using the passage-to-passage averaging operator. This transformation is initiated by decomposing the velocity field in equation (45) according to equation (41). The resulting equation is then operated upon by equation (25). The reference blade row for this operation is the j th stator. The resulting expression for the passage-to-passage averaged tangential momentum equation is of the form

$$\frac{\partial}{\partial t_j} r \lambda_j \bar{\rho} \bar{V}_\theta + \frac{\partial}{\partial r} r \lambda_j \bar{\rho} \bar{V}_r \bar{V}_\theta + \frac{\partial}{\partial \theta} \left(\lambda_j \bar{\rho} \bar{V}_\theta \bar{V}_\theta + \lambda_j p \right) + \frac{\partial}{\partial z} r \lambda_j \bar{\rho} \bar{V}_z \bar{V}_\theta + \lambda_j \bar{\rho} \bar{V}_r \bar{V}_\theta \\ = \frac{\partial}{\partial r} r \lambda_j \left(\bar{\tau}_{r\theta} - \frac{\bar{\rho} \bar{V}_r \bar{V}_\theta}{\bar{\rho} \bar{V}_r \bar{V}_\theta} - \frac{\bar{\rho} \bar{V}_r \bar{V}_\theta}{\bar{\rho} \bar{V}_r \bar{V}_\theta} - \frac{\bar{\rho} \bar{V}_r \bar{V}_\theta}{\bar{\rho} \bar{V}_r \bar{V}_\theta} \right) + \frac{\partial}{\partial \theta} \lambda_j \left(\bar{\tau}_{\theta\theta} - \frac{\bar{\rho} \bar{V}_\theta \bar{V}_\theta}{\bar{\rho} \bar{V}_\theta \bar{V}_\theta} - \frac{\bar{\rho} \bar{V}_\theta \bar{V}_\theta}{\bar{\rho} \bar{V}_\theta \bar{V}_\theta} - \frac{\bar{\rho} \bar{V}_\theta \bar{V}_\theta}{\bar{\rho} \bar{V}_\theta \bar{V}_\theta} \right) \\ + \frac{\partial}{\partial z} r \lambda_j \left(\bar{\tau}_{z\theta} - \frac{\bar{\rho} \bar{V}_z \bar{V}_\theta}{\bar{\rho} \bar{V}_z \bar{V}_\theta} - \frac{\bar{\rho} \bar{V}_z \bar{V}_\theta}{\bar{\rho} \bar{V}_z \bar{V}_\theta} - \frac{\bar{\rho} \bar{V}_z \bar{V}_\theta}{\bar{\rho} \bar{V}_z \bar{V}_\theta} \right) + \lambda_j \left(\bar{\tau}_{r\theta} - \frac{\bar{\rho} \bar{V}_r \bar{V}_\theta}{\bar{\rho} \bar{V}_r \bar{V}_\theta} - \frac{\bar{\rho} \bar{V}_r \bar{V}_\theta}{\bar{\rho} \bar{V}_r \bar{V}_\theta} - \frac{\bar{\rho} \bar{V}_r \bar{V}_\theta}{\bar{\rho} \bar{V}_r \bar{V}_\theta} \right) \\ + F_{IN}^{(\theta R)} + F_V^{(\theta R)} + F_{IN}^{(\theta S)} + F_V^{(\theta S)} \quad (48)$$

Similar expressions can be derived for the radial and axial momentum equations. They are given in the appendix, along with the passage-to-passage averaged energy equation. The variables $F_{IN}^{(\theta S)}$ and $F_V^{(\theta S)}$ in equation (48) represent the inviscid and viscous body forces generated by the neighboring stator blade rows. They are equal to

$$\begin{aligned}
F_{IN}^{(\theta S)} = \frac{L}{2\pi} \frac{1}{L} & \left\{ \sum_{l=0}^{L-1} \bar{p} \Big|_{\theta=\alpha+\theta_3+\frac{2\pi l}{L}} - \bar{p} \Big|_{\theta=\alpha+\theta_4+\frac{2\pi l}{L}} \right\} \\
& + \frac{1}{\pi} \sum_{l=0}^{L-1} \bar{p} \Big|_{\theta=\alpha+\theta_3+\frac{2\pi l}{L}} \sum_{k=1}^{\infty} \cos kM \left(\theta - \alpha - \theta_3 - \frac{2\pi l}{L} \right) \\
& - \frac{1}{\pi} \sum_{l=0}^{L-1} \bar{p} \Big|_{\theta=\alpha+\theta_4+\frac{2\pi l}{L}} \sum_{k=1}^{\infty} \cos kM \left(\theta - \alpha - \theta_4 - \frac{2\pi l}{L} \right) \quad (49)
\end{aligned}$$

$$\begin{aligned}
F_V^{(\theta S)} = \frac{L}{2\pi} \frac{1}{L} & \left\{ \sum_{l=0}^{L-1} \left(r_{\bar{r}} \frac{\partial \theta_3}{\partial r} - \bar{\tau}_{\theta\theta} + r_{\bar{r}} z_{\theta} \frac{\partial \theta_3}{\partial z} \right) \Big|_{\theta=\alpha+\theta_3+\frac{2\pi l}{L}} \right. \\
& \left. - \left(r_{\bar{r}} \frac{\partial \theta_4}{\partial r} - \bar{\tau}_{\theta\theta} + r_{\bar{r}} z_{\theta} \frac{\partial \theta_4}{\partial z} \right) \Big|_{\theta=\alpha+\theta_4+\frac{2\pi l}{L}} \right\} \\
& + \frac{1}{\pi} \sum_{l=0}^{L-1} \left(r_{\bar{r}} \frac{\partial \theta_3}{\partial r} - \bar{\tau}_{\theta\theta} + r_{\bar{r}} z_{\theta} \frac{\partial \theta_3}{\partial z} \right) \Big|_{\theta=\alpha+\theta_3+\frac{2\pi l}{L}} \\
& \times \sum_{k=1}^{\infty} \cos kM \left(\theta - \alpha - \theta_3 - \frac{2\pi l}{L} \right) \\
& - \frac{1}{\pi} \sum_{l=0}^{L-1} \left(r_{\bar{r}} \frac{\partial \theta_4}{\partial r} - \bar{\tau}_{\theta\theta} + r_{\bar{r}} z_{\theta} \frac{\partial \theta_4}{\partial z} \right) \Big|_{\theta=\alpha+\theta_4+\frac{2\pi l}{L}} \\
& \times \sum_{k=1}^{\infty} \cos kM \left(\theta - \alpha - \theta_4 - \frac{2\pi l}{L} \right) \quad (50)
\end{aligned}$$

The expressions in parentheses in equations (49) and (50) represent the axisymmetric component of the body force; the remaining terms represent the nonaxisymmetric component. These forces vanish outside the stator passages. The underscored terms in equation (48) represent the mixing stress generated by the aperiodic component of the steady velocity field. Thus the total mixing stress associated with the average-passage equation system is composed of a stress due to the steady, aperiodic velocity field, a stress generated by the coherent,

unsteady velocity field, and the Reynolds stress. The total stress can be expressed as

$$R_{ij} = \overline{\hat{v}_i \hat{v}_j} + \overline{\hat{v}_i \hat{v}_j} + \overline{\hat{v}_i \hat{v}_j} \quad (51)$$

where subscripts i and j are assigned the values 1, 2, and 3, which correspond to the radial, tangential, and axial coordinates, respectively. This second-order tensor is generic to the average-passage equation system. Its evaluation, along with the body forces and energy sources, constitutes the closure problem for this equation system. Two possible approaches for solving this problem are presented in the next section.

This completes the theoretical development of the average-passage equation system. This equation system was derived without introducing any additional assumptions other than those encompassed in the Navier-Stokes equations themselves. The equation system was constructed to be spatially periodic, with a period equal to the pitch of a reference blade row. Hence, in general, there is one such equation system for each blade row of a multistage machine.

CLOSURE MODELING

The average-passage equation system, like the Reynolds-averaged Navier-Stokes equations, does not contain sufficient information to determine its solution. To close this system of equations, one must construct a mathematical model for the mixing stress tensor R_{ij} (eq. (51)), the body forces, and the energy sources. Two approaches to this problem are outlined.

The first approach makes use of the capability that exists for simulating the axisymmetric flow field in multistage machines (ref. 4). This analysis, often referred to as "through-flow analysis," has been tuned over the years to accurately simulate the flow in turbomachinery at design and near-design operating conditions. This form of analysis includes models for the body forces and the energy sources. These same models could also be used in the present analysis.

Recently a model has been proposed by Adkins and Smith (ref. 3) by which the effects of mixing can be included in through-flow analyses. They suggest that the angular momentum, total temperature, and total pressure field be mixed according to a simple two-dimensional diffusion equation. The diffusion coefficient associated with this equation is developed from inviscid, secondary-flow theory that has been empirically corrected for the effects of viscosity and interactions with downstream bladings. Their work could serve as a basis for developing a model for the mixing stress as defined in the present analysis, since it is this stress field that produces the mixing they attempted to model. Away from solid boundaries the diffusion model is analogous to Boussinesq's eddy-viscosity model. Thus it appears reasonable to assume that R_{ij} can be approximated by an eddy viscosity model in the interior flow region, the eddy viscosity being directly proportional to the diffusion coefficient of reference 3. Near solid boundaries this model must be modified to acknowledge the presence of the boundary. This modification could resemble that used for the inner region of a turbulent boundary layer. The resulting mixing stress model would thus be a composite. A similar approach, based on

Boussinesq's eddy-conductivity model, could be used to develop expressions for the correlations involving the product of velocity and enthalpy that appear in the energy equation (A3). This approach, along with the suggested models for the mixing stress, the body forces, and the energy source, is sufficient to close the average-passage equation system.

An alternative approach to the closure problem is to address separately the contribution to the mixing stress, the body forces, and the energy sources made by the coherent velocity from that made by the turbulent fluctuations. The contribution of the coherent velocity field to the mixing correlations can be decomposed into that attributed to an incident gust and that attributed to a radiated velocity field. The radiated field results from the interaction of the gust with blading. The incident-gust velocity field is constructed by superimposing the passage-to-passage averaged velocity field of each blade row. Its mathematical form referenced to the n^{th} stator is

$$v_1^{(G)} = \sum_{\substack{J=1 \\ J \neq M}}^{J_{\max}} \left[\tilde{\tilde{v}}_1^{(J)}(r, \theta, z) - \tilde{\tilde{v}}_L(r, z) \right] + \sum_{k=1}^{K_{\max}} \left[\tilde{\tilde{v}}_1^{(k)}(r, \theta - \omega t, z) - \tilde{\tilde{v}}_1(r, z) \right]$$

$l = 1, 2, 3 \quad (52)$

where $\tilde{\tilde{v}}_1$ denotes the mass-averaged axisymmetric velocity field, J_{\max} the number of stationary blade rows, and K_{\max} the number of rotating blade rows. Added to this velocity field is a radiated field that, because of the boundary conditions applied at solid surfaces, must be equal and opposite to $v_1^{(G)}$ at these surfaces. An evaluation by numerical simulation of this field without introducing any simplifying assumptions would require a direct simulation of the unsteady deterministic flow field in a multistage machine. Such a simulation is well beyond the limits of any of today's supercomputers, including the Cray II. Therefore semiempirical methods must be resorted to for modeling the radiated velocity field and its contribution to the various correlations. Fortunately the problem of predicting this field has been addressed in a number of turbomachinery research programs over the years. In particular the problems of forced vibration and aerodynamic noise require a knowledge of the radiated velocity field before fluctuating airloads and noise can be predicted. A number of models have been developed as a result of research in these problem areas. Because these models are in general only applicable to the inviscid flow region, they must be extended to include the viscous region surrounding the blading. This will be a formidable task. It will require detailed experimental measurements and highly refined numerical simulations to reveal the physics of the unsteady-flow process in this region. The data obtained from these studies will provide a basis for developing models for the correlations associated with the deterministic velocity field. Parallel with this effort, a research program into the effects of a highly unsteady coherent free stream on the turbulent boundary-layer correlations (i.e., Reynolds stress, etc.) needs to be pursued. The unsteady coherent structure could have a significant effect on the turbulent correlations since the length and time scales of coherent structure can be comparable to the length and time scales of the large

eddies in a turbulent boundary layer. Finally the importance of the turbulent correlation relative to those generated by the deterministic velocity field will have to be assessed.

CONCLUDING REMARKS

This report presents a rigorous derivation of the average-passage equation system. These equations have a closure problem that is quite similar to that for the Reynolds-averaged Navier-Stokes equations. The task of scaling the terms in this equation set has not been undertaken. If, however, this task could be executed successfully and if the closure problem associated with the dominant correlations could be solved, the resulting scaled system could provide a more fundamental basis for the analysis of turbomachinery flow than currently exists.

APPENDIX - AVERAGE-PASSAGE EQUATION SYSTEM

This appendix summarizes the three-dimensional average-passage equation system. The continuity equation and the tangential momentum equation were derived in the main body of this report. They will be restated to complete the equation set. The governing field equations averaged with respect to the j^{th} stator are

Continuity:

$$\frac{\partial r \lambda_j \bar{\rho}}{\partial t} + \frac{\partial}{\partial r} r \lambda_j \bar{\rho} \bar{V}_r + \frac{\partial}{\partial \theta} \lambda_j \bar{\rho} \bar{V}_\theta + \frac{\partial}{\partial z} r \lambda_j \bar{\rho} \bar{V}_z = 0 \quad (42)$$

Radial momentum equation:

$$\begin{aligned} & \frac{\partial}{\partial t} \lambda_j r \bar{\rho} \bar{V}_r + \frac{\partial}{\partial r} \lambda_j r \left(\bar{\rho} \bar{V}_r \bar{V}_r + \bar{p} \right) + \frac{\partial}{\partial \theta} \lambda_j \bar{\rho} \bar{V}_\theta \bar{V}_r + \frac{\partial}{\partial z} \lambda_j r \bar{\rho} \bar{V}_z \bar{V}_r \\ & = \left(\bar{p} + \bar{\rho} \bar{V}_\theta^2 - \bar{\tau}_{\theta\theta} \right) \lambda_j + \frac{\partial}{\partial r} \lambda_j \left(r \bar{\tau}_{rr} - r \bar{\rho} \hat{V}_r \hat{V}_r - r \overline{\hat{V}_r \hat{V}_r} - r \overline{\rho V'_r V'_r} \right) \\ & + \frac{\partial}{\partial r} \lambda_j \left(r \bar{\tau}_{\theta r} - \bar{\rho} \hat{V}_\theta \hat{V}_r - \overline{\hat{V}_\theta \hat{V}_r} - \overline{\rho V'_\theta V'_r} \right) \\ & + \frac{\partial}{\partial z} \lambda_j \left(r \bar{\tau}_{zr} - r \bar{\rho} \hat{V}_z \hat{V}_r - \overline{\hat{V}_z \hat{V}_r} - \overline{\rho V'_z V'_r} \right) \\ & + \overline{\hat{V}_\theta \hat{V}_\theta} \lambda_j + \overline{\hat{V}_\theta \hat{V}_\theta} \lambda_j + \overline{\rho V'_\theta V'_\theta} \lambda_j \\ & + F_{IN}^{(RR)} + F_V^{(RR)} + F_{IN}^{(RS)} + F_V^{(RS)} \end{aligned} \quad (A1)$$

The blade forces $F_{IN}^{(RS)}$, $F_V^{(RS)}$, $F_{IN}^{(RR)}$, and $F_V^{(RR)}$ are defined as

$$\begin{aligned}
 F_{IN}^{(RS)} = & -\frac{1}{2\pi} \sum_{l=0}^{N_S^1-1} r \left(\bar{p} \Big|_{\theta=\alpha+\theta_4+\frac{2\pi l}{N_S^1}} \frac{\partial \theta_4}{\partial r} - \bar{p} \Big|_{\theta=\alpha+\theta_3+\frac{2\pi l}{N_S^1}} \frac{\partial \theta_3}{\partial r} \right) \\
 & -\frac{1}{\pi} \sum_{l=0}^{N_S^1-1} \left[r \bar{p} \Big|_{\theta=\alpha+\theta_4+\frac{2\pi l}{N_S^1}} \frac{\partial \theta_4}{\partial r} \sum_{n=1}^{\infty} \cos nM \left(\theta - \alpha - \theta_4 - \frac{2\pi l}{N_S^1} \right) \right. \\
 & \left. - r \bar{p} \Big|_{\theta=\alpha+\theta_3+\frac{2\pi l}{N_S^1}} \frac{\partial \theta_3}{\partial r} \sum_{n=1}^{\infty} \cos nM \left(\theta - \alpha - \theta_3 - \frac{2\pi l}{N_S^1} \right) \right] \quad (A2)
 \end{aligned}$$

$$\begin{aligned}
F_V^{(RS)} = & \frac{1}{2\pi} \sum_{l=0}^{N_S^1-1} \left[\left(r_{\tau}^{\tau} \frac{\partial \theta_4}{\partial r} - \tau_{\theta r} + r_{\tau}^{\tau} \frac{\partial \theta_4}{\partial z} \right) \Big|_{\theta=\alpha+\theta_4+\frac{2\pi l}{N_S^1}} \right. \\
& \left. - \left(r_{\tau}^{\tau} \frac{\partial \theta_3}{\partial r} - \tau_{\theta r} + r_{\tau}^{\tau} \frac{\partial \theta_3}{\partial z} \right) \Big|_{\theta=\alpha+\theta_3+\frac{2\pi l}{N_S^1}} \right] \\
& + \frac{1}{\pi} \sum_{l=0}^{N_S^1-1} \left(r_{\tau}^{\tau} \frac{\partial \theta_4}{\partial r} - \tau_{\theta r} + r_{\tau}^{\tau} \frac{\partial \theta_4}{\partial z} \right) \Big|_{\theta=\alpha-\theta_4+\frac{2\pi l}{N_S^1}} \\
& \times \sum_{n=1}^{\infty} \cos nM \left(\theta - \alpha - \theta_4 - \frac{2\pi l}{N_S^1} \right) \\
& - \frac{1}{\pi} \sum_{l=0}^{N_S^1-1} \left(r_{\tau}^{\tau} \frac{\partial \theta_3}{\partial r} - \tau_{\theta r} + r_{\tau}^{\tau} \frac{\partial \theta_3}{\partial z} \right) \Big|_{\theta=\alpha+\theta_3+\frac{2\pi l}{N_S^1}} \\
& \times \sum_{n=1}^{\infty} \cos nM \left(\theta - \alpha - \theta_3 - \frac{2\pi l}{N_S^1} \right) \tag{A3}
\end{aligned}$$

$$F_{IN}^{(RR)} = -\frac{1}{2\pi} \sum_{n=0}^{N_R^1-1} r \left(\bar{p} \Big|_{t=t_{ref} + \theta_1 + \theta_2 + \frac{2\pi(n-1)}{N_R^1} - \theta} \right) \frac{1}{\Omega} \frac{\partial \theta_2}{\partial r} - \bar{p} \Big|_{t=t_{ref} + \left(\theta_1 + \theta_1 + \frac{2\pi(n-1)}{N_R^1} - \theta \right)} \frac{1}{\Omega} \frac{\partial \theta_1}{\partial r} \quad (A4)$$

$$F_V^{(RR)} = \frac{1}{2\pi} \sum_{n=0}^{N_R^1-1} \left[\left(r \bar{\tau}_{rr} \frac{\partial \theta_2}{\partial r} - \bar{\tau}_{\theta r} + r \bar{\tau}_{zr} \frac{\partial \theta_2}{\partial z} \right) \Big|_{t=t_{ref} + \left(\theta_1 + \theta_2 + \frac{2\pi(N-1)}{N_R^1} - \theta \right)} \frac{1}{\Omega} - \left(r \bar{\tau}_{rr} \frac{\partial \theta_1}{\partial r} - \bar{\tau}_{\theta r} + r \bar{\tau}_{zr} \frac{\partial \theta_1}{\partial z} \right) \Big|_{t=t_{ref} + \left(\theta_1 + \theta_1 + \frac{2\pi(n-1)}{N_R^1} - \theta \right)} \frac{1}{\Omega} \right] \quad (A5)$$

Tangential momentum equation:

$$\begin{aligned} \frac{\partial}{\partial t_1} r \lambda_j \overline{\overline{\overline{\rho \tilde{V}}}}_{\theta} + \frac{\partial}{\partial r} \lambda_j r \overline{\overline{\overline{\rho \tilde{V}}}}_{r \tilde{V}}_{\theta} + \frac{\partial}{\partial \theta} \lambda_j \left(\overline{\overline{\overline{\rho \tilde{V}}}}_{\theta \tilde{V}}_{\theta} + \bar{p} \right) + \frac{\partial}{\partial z} r \lambda_j \overline{\overline{\overline{\rho \tilde{V}}}}_{z \tilde{V}}_{\theta} \\ = - \lambda_j \overline{\overline{\overline{\rho \tilde{V}}}}_{r \tilde{V}}_{\theta} + \lambda_j \left(\overline{\overline{\overline{\tau}_{r\theta}}} - \overline{\overline{\overline{\rho \tilde{V}}}}_{r \tilde{V}}_{\theta} - \overline{\overline{\overline{\rho \tilde{V}}}}_{r \tilde{V}}_{\theta} - \overline{\overline{\overline{\rho V'_r V'_\theta}}} \right) \\ + \frac{\partial}{\partial r} \lambda_j r \left(\overline{\overline{\overline{\tau}_{r\theta}}} - \overline{\overline{\overline{\rho \tilde{V}}}}_{r \tilde{V}}_{\theta} - \overline{\overline{\overline{\rho \tilde{V}}}}_{r \tilde{V}}_{\theta} - \overline{\overline{\overline{\rho V'_r V'_\theta}}} \right) \\ + \frac{\partial}{\partial r} \lambda_j \left(\overline{\overline{\overline{\tau}_{r\theta}}} - \overline{\overline{\overline{\rho \tilde{V}}}}_{r \tilde{V}}_{\theta} - \overline{\overline{\overline{\rho \tilde{V}}}}_{r \tilde{V}}_{\theta} - \overline{\overline{\overline{\rho V'_r V'_\theta}}} \right) \\ + \frac{\partial}{\partial z} \lambda_j r \left(\overline{\overline{\overline{\tau}_{z\theta}}} - \overline{\overline{\overline{\rho \tilde{V}}}}_{z \tilde{V}}_{\theta} - \overline{\overline{\overline{\rho \tilde{V}}}}_{z \tilde{V}}_{\theta} - \overline{\overline{\overline{\rho V'_z V'_\theta}}} \right) \\ + F_{IN}^{(\theta R)} + F_V^{(\theta R)} + F_{IN}^{(\theta S)} + F_V^{(\theta S)} \end{aligned} \quad (48)$$

The blade forces $F_{IN}^{(\theta S)}$, $F_V^{(\theta S)}$, $F_{IN}^{(\theta R)}$, and $F_V^{(\theta R)}$ are equal to

$$F_{IN}^{(\theta S)} = -\frac{1}{2\pi} \sum_{l=0}^{N_S^1-1} \left(\bar{P} \Big|_{\theta=\alpha+\theta_4+\frac{2\pi l}{N_S^1}} - \bar{P} \Big|_{\theta=\alpha+\theta_3+\frac{2\pi l}{N_S^1}} \right)$$

$$= -\frac{1}{\pi} \sum_{l=0}^{N_S^1-1} \left[\bar{P} \Big|_{\theta=\alpha+\theta_4+\frac{2\pi l}{N_S^1}} \sum_{n=1}^{\infty} \cos nM \left(\theta - \alpha - \theta_4 - \frac{2\pi l}{N_S^1} \right) \right.$$

$$\left. - \bar{P} \Big|_{\theta=\alpha+\theta_3+\frac{2\pi l}{N_S^1}} \sum_{n=1}^{\infty} \cos nM \left(\theta - \alpha - \theta_3 - \frac{2\pi l}{N_S^1} \right) \right] \quad (49)$$

$$\begin{aligned}
F_V(\theta_S) = & \frac{1}{2\pi} \sum_{l=0}^{N_S^1-1} \left[\left(r_{\bar{l}}^{\bar{l}} r_{\theta} \frac{\partial \theta_3}{\partial r} - \bar{r}_{\theta\theta} + r_{\bar{l}}^{\bar{l}} z_{\theta} \frac{\partial \theta_3}{\partial z} \right) \Big|_{\theta=\alpha+\theta_3+\frac{2\pi l}{N_S^1}} \right. \\
& \left. - \left(r_{\bar{l}}^{\bar{l}} r_{\theta} \frac{\partial \theta_4}{\partial r} - \bar{r}_{\theta\theta} + r_{\bar{l}}^{\bar{l}} z_{\theta} \frac{\partial \theta_4}{\partial z} \right) \Big|_{\theta=\alpha+\theta_4+\frac{2\pi l}{N_S^1}} \right] \\
& + \frac{1}{\pi} \sum_{l=0}^{N_S^1-1} \left(r_{\bar{l}}^{\bar{l}} r_{\theta} \frac{\partial \theta_3}{\partial r} - \bar{r}_{\theta\theta} + r_{\bar{l}}^{\bar{l}} z_{\theta} \frac{\partial \theta_3}{\partial z} \right) \Big|_{\theta=\alpha+\theta_3+\frac{2\pi l}{N_S^1}} \\
& \times \sum_{k=1}^{\infty} \cos kM \left(\theta - \alpha - \theta_3 - \frac{2\pi l}{N_S^1} \right) \\
& - \frac{1}{\pi} \sum_{l=0}^{N_S^1-1} \left(r_{\bar{l}}^{\bar{l}} r_{\theta} \frac{\partial \theta_4}{\partial r} - \bar{r}_{\theta\theta} + r_{\bar{l}}^{\bar{l}} z_{\theta} \frac{\partial \theta_4}{\partial z} \right) \Big|_{\theta=\alpha+\theta_4+\frac{2\pi l}{N_S^1}} \\
& \times \sum_{k=1}^{\infty} \cos kM \left(\theta - \alpha - \theta_4 - \frac{2\pi l}{N_S^1} \right) \quad (50)
\end{aligned}$$

$$F_{IN}^{(\theta R)} = -\frac{1}{2\pi} \sum_{n=0}^{N_R^1-1} \left(\bar{P} \Big|_{t=t_{ref} + \left(\theta_1 + \theta_1 + \frac{2\pi(n-1)}{N_R^1} - \theta \right) \frac{1}{\Omega}} - \bar{P} \Big|_{t=t_{ref} + \left(\theta_1 + \theta_2 + \frac{2\pi(n-1)}{N_R^1} - \theta \right) \frac{1}{\Omega}} \right) \quad (46)$$

$$F_V^{(\theta R)} = \frac{1}{2\pi} \sum_{n=0}^{N_R^1-1} \left[\left(r \frac{\partial \theta_2}{\partial r} \bar{\tau}_{r\theta} - \bar{\tau}_{\theta\theta} + r \frac{\partial \theta_2}{\partial z} \bar{\tau}_{z\theta} \right) \Big|_{t=t_{ref} + \left(\theta_1 + \theta_2 + \frac{2\pi(n-1)}{N_R^1} - \theta \right) \frac{1}{\Omega}} \right. \\ \left. - \left(r \frac{\partial \theta_1}{\partial r} \bar{\tau}_{r\theta} - \bar{\tau}_{\theta\theta} + r \frac{\partial \theta_1}{\partial z} \bar{\tau}_{z\theta} \right) \Big|_{t=t_{ref} + \left(\theta_1 + \theta_1 + \frac{2\pi(n-1)}{N_R^1} - \theta \right) \frac{1}{\Omega}} \right] \quad (47)$$

Axial momentum equation:

$$\frac{\partial}{\partial t_1} \lambda_j \bar{\rho} \bar{V}_z + \frac{\partial}{\partial r} \lambda_j r \bar{\rho} \bar{V}_r \bar{V}_z + \frac{\partial}{\partial \theta} \lambda_j \bar{\rho} \bar{V}_\theta \bar{V}_z + \frac{\partial}{\partial z} \lambda_j \left(r \bar{\rho} \bar{V}_z \bar{V}_z + r \bar{P} \right) \\ = \frac{\partial}{\partial r} \lambda_j \left(\bar{\tau}_{rz} - r \bar{\rho} \hat{V}_r \hat{V}_z - r \bar{\rho} \hat{V}_r \hat{V}_z - r \bar{\rho} V_r' V_z' \right) \\ + \frac{\partial}{\partial \theta} \lambda_j \left(\bar{\tau}_{\theta z} - \bar{\rho} \hat{V}_\theta \hat{V}_z - \bar{\rho} \hat{V}_\theta \hat{V}_z - \bar{\rho} V_\theta' V_z' \right) \\ + \frac{\partial}{\partial z} \lambda_j \left(\bar{\tau}_{zz} - r \bar{\rho} \hat{V}_z \hat{V}_z - r \bar{\rho} \hat{V}_z \hat{V}_z - r \bar{\rho} V_z' V_z' \right) \\ + F_{IN}^{(ZR)} + F_V^{(ZR)} + F_{IN}^{(ZS)} + F_V^{(ZS)} \quad (A6)$$

The blade forces $F_{IN}^{(ZS)}$, $F_V^{(ZS)}$, $F_{IN}^{(ZR)}$, and $F_V^{(ZR)}$ are equal to

$$F_{IN}^{(ZS)} = -\frac{1}{2\pi} \sum_{l=0}^{N_S^1-1} r \left(\bar{p} \Big|_{\theta=\alpha+\theta_3+\frac{2\pi l}{N_S^1}} \frac{\partial \theta_3}{\partial z} - \bar{p} \Big|_{\theta=\alpha+\theta_4+\frac{2\pi l}{N_S^1}} \frac{\partial \theta_4}{\partial z} \right)$$

$$-\frac{1}{\pi} \sum_{l=0}^{N_S^1-1} \left[r \bar{p} \Big|_{\theta=\alpha+\theta_3+\frac{2\pi l}{N_S^1}} \frac{\partial \theta_3}{\partial z} \sum_{n=1}^{\infty} \cos nM \left(\theta - \alpha - \theta_3 - \frac{2\pi l}{N_S^1} \right) \right.$$

$$\left. - r \bar{p} \Big|_{\theta=\alpha+\theta_4+\frac{2\pi l}{N_S^1}} \frac{\partial \theta_4}{\partial z} \sum_{n=1}^{\infty} \cos nM \left(\theta - \alpha - \theta_4 - \frac{2\pi l}{N_S^1} \right) \right] \quad (A7)$$

$$\begin{aligned}
F_V(ZS) &= \frac{1}{2\pi} \sum_{l=0}^{N_S^1-1} \left[\left(r_{\bar{r}}^{\bar{r}} \frac{\partial \theta_4}{\partial z} - \bar{r}^{\bar{r}} \theta_z + r_{\bar{r}}^{\bar{r}} \frac{\partial \theta_4}{\partial z} \right) \Big|_{\theta=\alpha+\theta_4+\frac{2\pi l}{N_S^1}} \right. \\
&\quad \left. - \left(r_{\bar{r}}^{\bar{r}} \frac{\partial \theta_3}{\partial z} - \bar{r}^{\bar{r}} \theta_z + r_{\bar{r}}^{\bar{r}} \frac{\partial \theta_3}{\partial z} \right) \Big|_{\theta=\alpha+\theta_3+\frac{2\pi l}{N_S^1}} \right] \\
&\quad + \frac{1}{\pi} \sum_{l=0}^{N_S^1-1} \left(r_{\bar{r}}^{\bar{r}} \frac{\partial \theta_4}{\partial z} - \bar{r}^{\bar{r}} \theta_z + r_{\bar{r}}^{\bar{r}} \frac{\partial \theta_4}{\partial z} \right) \Big|_{\theta=\alpha+\theta_4+\frac{2\pi l}{N_S^1}} \\
&\quad \times \sum_{n=1}^{\infty} \cos nM \left(\theta - \alpha - \theta_4 - \frac{2\pi l}{N_S^1} \right) \\
&\quad - \frac{1}{\pi} \sum_{l=0}^{N_S^1-1} \left(r_{\bar{r}}^{\bar{r}} \frac{\partial \theta_3}{\partial z} - \bar{r}^{\bar{r}} \theta_z + r_{\bar{r}}^{\bar{r}} \frac{\partial \theta_3}{\partial z} \right) \Big|_{\theta=\alpha+\theta_3+\frac{2\pi l}{N_S^1}} \\
&\quad \times \sum_{n=1}^{\infty} \cos nM \left(\theta - \alpha - \theta_3 - \frac{2\pi l}{N_S^1} \right) \tag{A8}
\end{aligned}$$

$$F_{IN}^{(ZR)} = -\frac{1}{2\pi} \sum_{n=0}^{N_R^1-1} r(\bar{p}) \left(\left| t=t_{ref} + \left(\theta_1 + \theta_2 + \frac{2\pi(n-1)}{N_R^1} - \theta \right) \frac{1}{\Omega} \right. \right. \\ \left. \left. - \bar{p} \left| t=t_{ref} + \left(\theta_1 + \theta_1 + \frac{2\pi(n-1)}{N_R^1} - \theta \right) \frac{1}{\Omega} \right. \right) \frac{\partial \theta_2}{\partial z} \right) \quad (A9)$$

$$F_V^{(ZR)} = \frac{1}{2\pi} \sum_{n=0}^{N_R^1-1} \left[\left(r_{\bar{r}rz} \frac{\partial \theta_2}{\partial r} - \bar{r}_{\theta z} + r_{\bar{r}zz} \frac{\partial \theta_2}{\partial z} \right) \left| t=t_{ref} + \left(\theta_1 + \theta_2 + \frac{2\pi(n-1)}{N_R^1} - \theta \right) \frac{1}{\Omega} \right. \right. \\ \left. \left. - \left(r_{\bar{r}rz} \frac{\partial \theta_1}{\partial r} - \bar{r}_{\theta z} + r_{\bar{r}zz} \frac{\partial \theta_1}{\partial z} \right) \left| t=t_{ref} + \left(\theta_1 + \theta_1 + \frac{2\pi(n-1)}{N_R^1} - \theta \right) \frac{1}{\Omega} \right. \right) \right] \quad (A10)$$

Energy equation:

$$\begin{aligned}
& \frac{\partial}{\partial t_1} r \lambda_j \overline{\overline{\overline{\rho \hat{v}}}}_{\theta} + \frac{\partial}{\partial r} r \lambda_j \overline{\overline{\overline{\rho \hat{v}}}}_{r \hat{H}_0} + \frac{\partial}{\partial \theta} \lambda_j \overline{\overline{\overline{\rho \hat{v}}}}_{\theta \hat{H}_0} + \frac{\partial}{\partial z} r \lambda_j \overline{\overline{\overline{\rho \hat{v}}}}_{z \hat{H}_0} \\
& = \frac{\partial}{\partial r} r \lambda_j \left(\overline{\overline{\overline{\hat{v}}}}_{r \tau_{rr}} + \overline{\overline{\overline{\hat{v}}}}_{\theta \tau_{r\theta}} + \overline{\overline{\overline{\hat{v}}}}_{z \tau_{rz}} \right) + \frac{\partial}{\partial \theta} \lambda_j \left(\overline{\overline{\overline{\hat{v}}}}_{r \tau_{\theta r}} + \overline{\overline{\overline{\hat{v}}}}_{\theta \tau_{\theta\theta}} + \overline{\overline{\overline{\hat{v}}}}_{z \tau_{\theta z}} \right) \\
& + \frac{\partial}{\partial z} r \lambda_j \left(\overline{\overline{\overline{\hat{v}}}}_{r \tau_{zr}} + \overline{\overline{\overline{\hat{v}}}}_{\theta \tau_{z\theta}} + \overline{\overline{\overline{\hat{v}}}}_{z \tau_{zz}} \right) \\
& + \frac{\partial}{\partial r} r \lambda_j K \frac{\partial \overline{\overline{\overline{T}}}}{\partial r} + \frac{\partial}{\partial \theta} \lambda_j \frac{K}{r} \frac{\partial \overline{\overline{\overline{T}}}}{\partial \theta} + \frac{\partial}{\partial z} r \lambda_j K \frac{\partial \overline{\overline{\overline{T}}}}{\partial z} \\
& - \frac{\partial}{\partial r} r \lambda_j \left(\overline{\overline{\overline{\rho \hat{v}}}}_{r \hat{H}_0} + \overline{\overline{\overline{\rho \hat{v}}}}_{r \hat{H}_0} + \overline{\overline{\overline{\rho v'_r H'_0}}} \right) - \frac{\partial}{\partial r} \lambda_j \left(\overline{\overline{\overline{\rho \hat{v}}}}_{\theta \hat{H}_0} + \overline{\overline{\overline{\rho \hat{v}}}}_{\theta \hat{H}_0} + \overline{\overline{\overline{\rho v'_\theta H'_0}}} \right) \\
& - \frac{\partial}{\partial z} r \lambda_j \left(\overline{\overline{\overline{\rho \hat{v}}}}_{z \hat{H}_0} + \overline{\overline{\overline{\rho \hat{v}}}}_{z \hat{H}_0} + \overline{\overline{\overline{\rho v'_z H'_0}}} \right) \\
& + \frac{\partial}{\partial r} r \lambda_j \left(\overline{\overline{\overline{\hat{v}}}}_{r \tau_{rr}} + \overline{\overline{\overline{\hat{v}}}}_{r \tau_{rr}} + \overline{\overline{\overline{v'_{r r}}}} + \overline{\overline{\overline{\hat{v}}}}_{\theta \tau_{r\theta}} + \overline{\overline{\overline{\hat{v}}}}_{\theta \tau_{r\theta}} + \overline{\overline{\overline{v'_{r \theta}}}} + \overline{\overline{\overline{\hat{v}}}}_{z \tau_{rz}} + \overline{\overline{\overline{\hat{v}}}}_{z \tau_{rz}} \right) \\
& + \overline{\overline{\overline{v'_{z \tau_{rz}}}}} + \frac{\partial}{\partial \theta} \lambda_j \left(\overline{\overline{\overline{\hat{v}}}}_{r \tau_{\theta r}} + \overline{\overline{\overline{\hat{v}}}}_{r \tau_{\theta r}} + \overline{\overline{\overline{v'_{r \theta}}}} \right) \\
& + \overline{\overline{\overline{\hat{v}}}}_{\theta \tau_{\theta\theta}} + \overline{\overline{\overline{\hat{v}}}}_{\theta \tau_{\theta\theta}} + \overline{\overline{\overline{v'_{\theta \theta}}}} + \overline{\overline{\overline{\hat{v}}}}_{z \tau_{\theta z}} + \overline{\overline{\overline{\hat{v}}}}_{z \tau_{\theta z}} + \overline{\overline{\overline{v'_{z \theta}}}} \Big) \\
& + \frac{\partial}{\partial z} r \lambda_j \left(\overline{\overline{\overline{\hat{v}}}}_{r \tau_{zr}} + \overline{\overline{\overline{\hat{v}}}}_{r \tau_{zr}} + \overline{\overline{\overline{v'_{r z}}}} \right) \\
& + \overline{\overline{\overline{\hat{v}}}}_{\theta \tau_{z\theta}} + \overline{\overline{\overline{\hat{v}}}}_{\theta \tau_{z\theta}} + \overline{\overline{\overline{v'_{\theta z}}}} + \overline{\overline{\overline{\hat{v}}}}_{z \tau_{zz}} + \overline{\overline{\overline{\hat{v}}}}_{z \tau_{zz}} + \overline{\overline{\overline{v'_{z z}}}} \Big)
\end{aligned}$$

$$+ \hat{E} - \frac{1}{2\pi} \sum_{l=0}^{N_S^1-1} \left(K \frac{\partial T}{\partial r} \frac{\partial \theta_4}{\partial r} - \frac{K}{r} \frac{\partial T}{\partial \theta} + K \frac{\partial T}{\partial z} \frac{\partial \theta_4}{\partial z} \right) \Bigg|_{\theta=\alpha+\theta_4+\frac{2\pi l}{N_S^1}}$$

$$+ \frac{1}{2\pi} \sum_{l=0}^{N_S^1-1} \left(K \frac{\partial T}{\partial r} \frac{\partial \theta_3}{\partial r} - \frac{K}{r} \frac{\partial T}{\partial \theta} + K \frac{\partial T}{\partial z} \frac{\partial \theta_3}{\partial z} \right) \Bigg|_{\theta=\alpha+\theta_3+\frac{2\pi l}{N_S^1}}$$

$$- \frac{1}{\pi} \sum_{l=0}^{N_S^1-1} \left(K \frac{\partial T}{\partial r} \frac{\partial \theta_4}{\partial r} - \frac{K}{r} \frac{\partial T}{\partial \theta} + K \frac{\partial T}{\partial z} \frac{\partial \theta_4}{\partial z} \right) \Bigg|_{\theta=\alpha+\theta_4+\frac{2\pi l}{N_S^1}}$$

$$\times \sum_{n=1}^{\infty} \cos nM \left(\theta - \alpha - \theta_4 - \frac{2\pi l}{N_S^1} \right)$$

$$+ \frac{1}{\pi} \sum_{l=0}^{N_S^1-1} \left(K \frac{\partial T}{\partial r} \frac{\partial \theta_3}{\partial r} - \frac{K}{r} \frac{\partial T}{\partial \theta} + K \frac{\partial T}{\partial z} \frac{\partial \theta_3}{\partial z} \right) \Bigg|_{\theta=\alpha+\theta_3+\frac{2\pi l}{N_S^1}}$$

$$\times \sum_{n=1}^{\infty} \left(\cos nM \theta - \alpha - \theta_3 - \frac{2\pi l}{N_S^1} \right)$$

(A11)

where the energy source \hat{E} is equal to

$$\begin{aligned}
 \hat{E} = & -\frac{1}{2\pi} \sum_{n=0}^{N_R^1-1} \left[\left(\bar{\rho} \Omega r \tilde{e}_0 + \bar{\rho} \tilde{V}_\theta \tilde{H}_0 \right) \Big|_{t=t_{ref} + \left(\theta_1 + \theta_1 + \frac{2\pi(n-1)}{N_R^1} - \theta \right) \frac{1}{\Omega}} \right. \\
 & \left. - \left(\bar{\rho} \Omega r \tilde{e}_0 + \bar{\rho} \tilde{V}_\theta \tilde{H}_0 \right) \Big|_{t=t_{ref} + \left(\theta_1 + \theta_2 + \frac{2\pi(n-1)}{N_R^1} - \theta \right) \frac{1}{\Omega}} \right] \\
 & - \frac{1}{2\pi} \sum_{n=0}^{N_R^1-1} \left[r \left(\tilde{V}_{\theta \bar{r} \theta} + k \frac{\partial T}{\partial r} \right) \Big|_{t=t_{ref} + \left(\theta_1 + \theta_1 + \frac{2\pi(n-1)}{N_R^1} - \theta \right) \frac{1}{\Omega}} \frac{\partial \theta_1}{\partial r} \right. \\
 & \left. - r \left(\tilde{V}_{\theta \bar{r} \theta} + k \frac{\partial T}{\partial r} \right) \Big|_{t=t_{ref} + \left(\theta_1 + \theta_2 + \frac{2\pi(n-1)}{N_R^1} - \theta \right) \frac{1}{\Omega}} \frac{\partial \theta_2}{\partial r} \right] \\
 & + \frac{1}{2\pi} \sum_{n=0}^{N_R^1-1} \left[\left(\tilde{V}_{\theta \bar{r} \theta} + \frac{k}{r} \frac{\partial T}{\partial r} \right) \Big|_{t=t_{ref} + \left(\theta_1 + \theta_1 + \frac{2\pi(n-1)}{N_R^1} - \theta \right) \frac{1}{\Omega}} \right. \\
 & \left. - \left(\tilde{V}_{\theta \bar{r} \theta} + \frac{k}{r} \frac{\partial T}{\partial r} \right) \Big|_{t=t_{ref} + \left(\theta_1 + \theta_2 + \frac{2\pi(n-1)}{N_R^1} - \theta \right) \frac{1}{\Omega}} \right]
 \end{aligned}$$

$$\begin{aligned}
& - \frac{1}{2\pi} \sum_{n=0}^{N_R^1-1} \left[r \left(\tilde{V}_{\theta \bar{T} z \theta} + K \frac{\partial \bar{T}}{\partial z} \right) \right]_{t=t_{\text{ref}} + \left(\theta_1 + \theta_1 + \frac{2\pi(n-1)}{N_R^1} - \theta \right) \frac{1}{\Omega}} \frac{\partial \theta_1}{\partial z} \\
& - \left. r \left(\tilde{V}_{\theta \bar{T} z \theta} + K \frac{\partial \bar{T}}{\partial z} \right) \right]_{t=t_{\text{ref}} + \left(\theta_1 + \theta_2 + \frac{2\pi(n-1)}{N_R^1} - \theta \right) \frac{1}{\Omega}} \frac{\partial \theta_2}{\partial z} \quad (A12)
\end{aligned}$$

In equations (A11) and (A12) e_0 is the total internal energy, H_0 the total enthalpy, K the thermal conductivity, and T the absolute temperature.

REFERENCES

1. Smith, L.H., Jr.: The Radial-Equilibrium Equation of Turbomachinery. *J. Eng. Power*, vol. 88, no. 1, Jan. 1966, pp. 1-12.
2. Sehra, A.K.: Boundary Layer and Wake Modifications to Compressor Design Systems: The Effect of Blade-to-Blade Flow Variations on the Mean Flow Field of a Transonic Rotor. GT/PLD-144 MIT Gas Turbine and Plasma Dynamics Lab., 1979. (AD-A076204.)
3. Adkins, G.G., Jr.; and Smith, L.H., Jr.: Spanwise Mixing in Axial-Flow Turbomachines. *J. Eng. Power*, vol. 104, no. 1, Jan. 1982, pp. 97-110.
4. Hearsey, R.M.: A Computer Program for Axial Compressor Design. AFAPL-TR-73-66-Vol-1, Dayton Univ., 1973. (AD-764733.)
5. Hinze, J.O.: Turbulence. Second ed. McGraw-Hill Series in Mechanical Engineering, McGraw-Hill Book Co., Inc., 1975.
6. Cebeci, Tuncer; and Smith, A.M.O.: Analysis of Turbulent Boundary Layers. *Applied Mathematics and Mechanics*, vol. 15, Academic Press, 1974.
7. Johnston, J.P.: Internal Flows. Turbulence, B. Bradshaw, ed., *Topics in Applied Physics*, vol. 12, Springer-Verlag, 1976, pp. 109-169.
8. Lighthill, M.J.: Introduction to Fourier Analysis and Generalised Functions. *Cambridge Monographs on Mechanics and Applied Mathematics*, Cambridge University Press, 1964.
9. Kaplan, W.: Advanced Calculus. Third ed. Addison-Wesley, 1984.
10. Emmons, H.W.: Fundamentals of Gas Dynamics. High Speed Aerodynamics and Jet Propulsion, vol. 3, Princeton University Press, 1958.

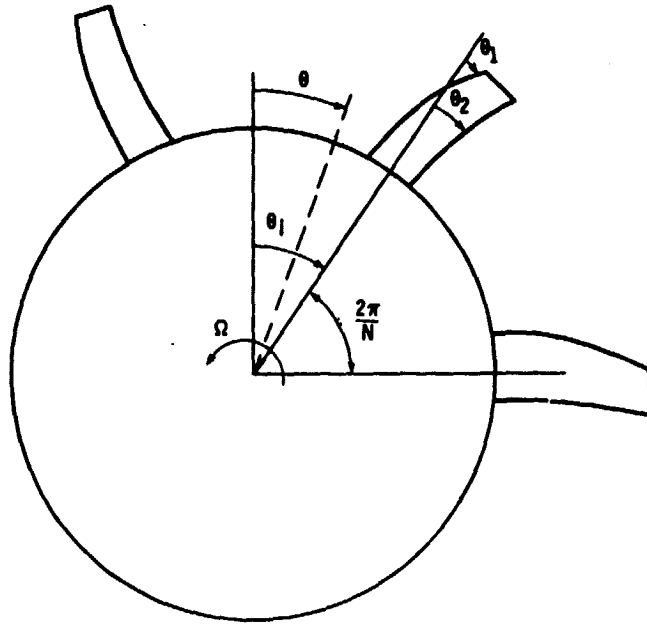

Figure 1. - Starting configuration of a rotor blade row.

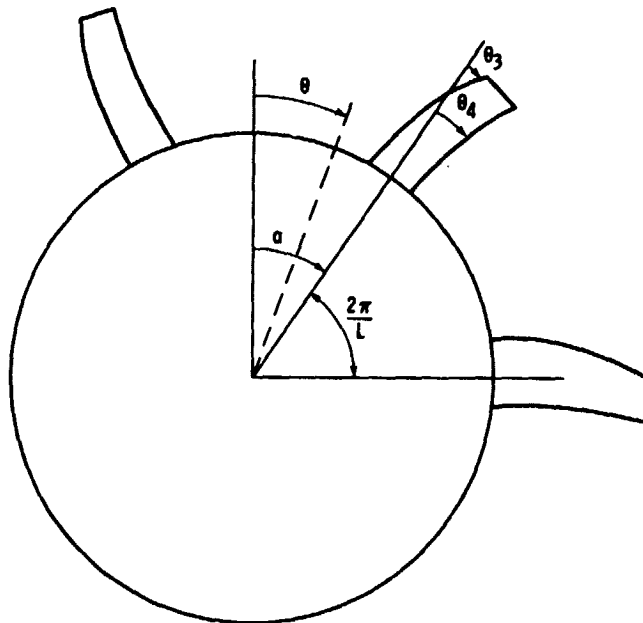

Figure 2. - Configuration of stator blade row.