

## **General Disclaimer**

### **One or more of the Following Statements may affect this Document**

- This document has been reproduced from the best copy furnished by the organizational source. It is being released in the interest of making available as much information as possible.
- This document may contain data, which exceeds the sheet parameters. It was furnished in this condition by the organizational source and is the best copy available.
- This document may contain tone-on-tone or color graphs, charts and/or pictures, which have been reproduced in black and white.
- This document is paginated as submitted by the original source.
- Portions of this document are not fully legible due to the historical nature of some of the material. However, it is the best reproduction available from the original submission.

JPL PUBLICATION 84-33

(NASA-CR-174170) MISSION SCIENCE VALUE-COST  
SAVINGS FROM THE ADVANCED IMAGING  
COMMUNICATION SYSTEM (AICS) (Jet Propulsion  
Lab.) 38 p HC A03/BE A01 CSCL 22A

N85-12905

Unclass

G3/12 24603

# Mission Science Value/Cost Savings From the Advanced Imaging Communication System (AICS)

Robert F. Rice

July 15, 1984

**NASA**

National Aeronautics and  
Space Administration

Jet Propulsion Laboratory  
California Institute of Technology  
Pasadena, California



JPL PUBLICATION 84-33

# Mission Science Value/Cost Savings From the Advanced Imaging Communication System (AICS)

Robert F. Rice

July 15, 1984



National Aeronautics and  
Space Administration

**Jet Propulsion Laboratory**  
California Institute of Technology  
Pasadena, California

The research described in this publication was carried out by the Jet Propulsion Laboratory, California Institute of Technology, under contract with the National Aeronautics and Space Administration.

## ACKNOWLEDGMENT

This report assigns significant dollar values/cost savings to the performance gains of an "Advanced Imaging Communication System (AICS)." The author wishes to acknowledge the contributions of talented individuals who have aided in the acceptance and practical realization of AICS concepts within the planetary program.

Of these, the technical contributions of colleagues Edward Hilbert, Jun-Ji Lee, K.Y. Liu, Marv Perlman, and Alan Schlutsmeyer have been fundamental throughout the development of AICS data compression and/or coding.

The achievement of successful flight and ground-based implementations to date was strongly influenced by the timely efforts of : Don Acord, John de Jong, William Graves, Pierre Estaria, Don Johnson, Charles Lahmeyer, Robert Miller, Richard Rice, and Sherry Wheelock.

The realization of standards for AICS coding, within the framework of packet telemetry, is owed almost entirely to Ed Greenberg and Adrian Hooke.

## ABSTRACT

An Advanced Imaging Communication System (AICS) was proposed in the mid-1970s as an alternative to the then-current Voyager data/communication system architecture. AICS achieved "virtually error-free" communication with little loss in the downlink data rate by concatenating a powerful Reed-Solomon block code with the Voyager convolutionally coded, Viterbi decoded downlink channel. The clean channel made feasible AICS sophisticated adaptive data compression techniques. Since then, both Voyager (for Uranus and Neptune encounters) and the Galileo mission have implemented AICS components, and the concatenated channel itself is heading for international standardization.

This report provides an analysis that assigns a dollar value/cost savings to AICS mission performance gains. The results show a conservative value or savings of **\$3 million for Voyager, \$4.5 million for Galileo, and as much as \$7-9.5 million per mission for future projects such as the proposed Mariner Mark II series.**

## TABLE OF CONTENTS

I.	INTRODUCTION . . . . .	1
	APPROACH . . . . .	2
	BACKGROUND AND AICS STATUS . . . . .	3
	Actual Implementations . . . . .	3
	Image Science Value Studies . . . . .	4
	Instrument Compression Studies . . . . .	4
II.	PERFORMANCE GAINS . . . . .	5
	MASS MEMORY IMPROVEMENT . . . . .	5
	Voyager Uranus/Neptune . . . . .	5
	Galileo . . . . .	5
	MM II . . . . .	5
	DOWNLINK IMPROVEMENTS . . . . .	6
	Direct Improvements to Non-Imaging and Imaging . . . . .	6
	Overall Downlink Gains . . . . .	8
	GROUNDLINK IMPROVEMENTS . . . . .	13
III.	MISSION VALUE/COSTS . . . . .	15
	COST PER dB IMPROVEMENT BY STANDARD MEANS . . . . .	16
	Basic Rule-of-Thumb Parameters . . . . .	16
	Direct Costs for Increased On-Board Mass Memory . . . . .	16
	Direct Costs for Increased Downlink Rates . . . . .	18
	Costs for Ground Communication . . . . .	22
	OVERALL AICS MISSION VALUE . . . . .	26
	AICS Costs . . . . .	28
	REFERENCES . . . . .	30

## TABLE OF CONTENTS (Continued)

### Tables

1. Mass Memory Gain Factors . . . . .	6
2. Individual Downlink Gain Factors . . . . .	9
3. Overall AICS Downlink Gains . . . . .	12
4. Convolutional Channel Downlink Rates . . . . .	13
5. Groundlink Values for AICS Performance Gains . . . . .	26
6. AICS Mission Value . . . . .	27

### Figures

1. Baseline Voyager/Galileo Data/Communication System . . . . .	1
2. Advanced Imaging Communication System (AICS) . . . . .	1
3. Non-Imaging Architecture: Baseline vs. AICS . . . . .	7
4. Imaging Architecture: Baseline vs. AICS . . . . .	8
5. Reverse Baseline Downlink Diagram . . . . .	9
6. Reverse AICS Downlink Diagram . . . . .	10
7. Costs for dB Gain From Transmitter Power . . . . .	19
8. The Hourly Cost of a dB at the Stations . . . . .	20
9. Costs for dB Gain at the DSN . . . . .	21
10. Groundlink Costs . . . . .	23



## I. INTRODUCTION

The concept of an Advanced Imaging Communication System (AICS) was proposed and analyzed in 1974<sup>[1]</sup>. AICS was intended as a replacement for the baseline Voyager data system/communication system architecture which later also became the Galileo baseline. The two architectures are compared in Figs. 1 and 2.

AICS supplemented the Voyager communication link by concatenating a powerful Reed-Solomon (RS) block code with the existing convolutionally coded, Viterbi decoded channel. This provides "virtually error-free" communication without significant reductions in real data rate. The latter achievement then allows the practical use of sophisticated data compression to represent the various spacecraft data sources. Further, the Golay block code used on non-imaging data could be discarded, eliminating a significant burden in parity overhead.

The original AICS description used the RM2 image compression algorithm as a vehicle for demonstrating the significant end-to-end advantages of the AICS elements<sup>[1],[2]</sup>. This architecture received a patent in 1976<sup>[3]</sup>.

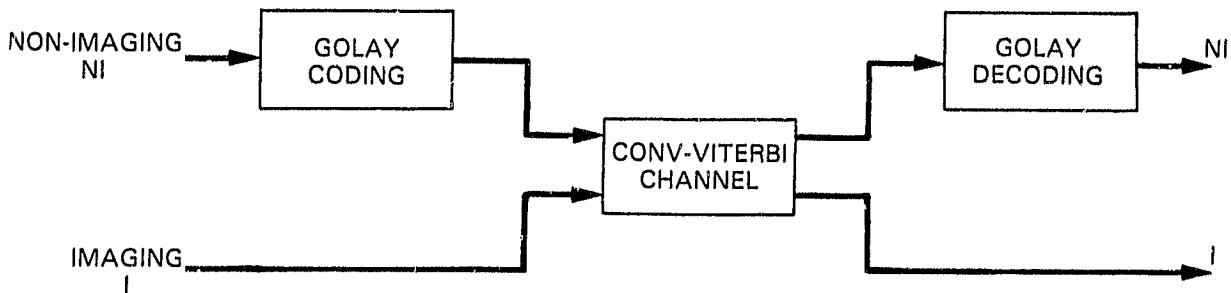

Fig. 1. Baseline Voyager/Galileo Data/Communication System

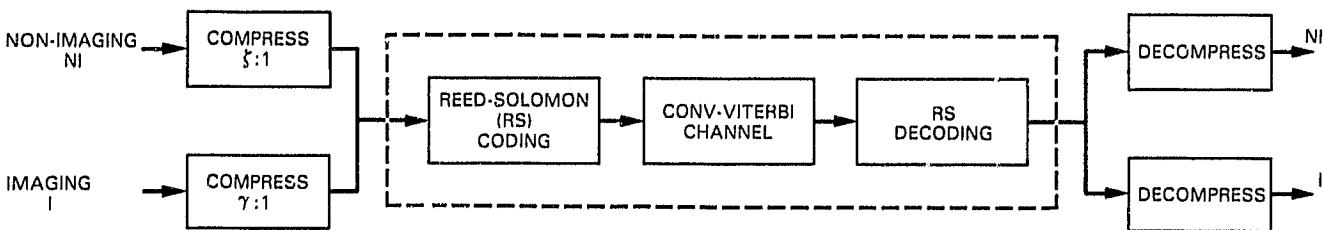

Fig. 2. Advanced Imaging Communication System (AICS)

Modifications incorporating AICS elements of coding and compression have since been made to Voyager and Galileo. Major gains in "science value" are expected from their joint use at the Voyager Uranus/Neptune encounters and the Galileo encounter with Jupiter.

While significant, such applications do not fully tap the potential advantages possible. AICS must be incorporated in the early planning and development stages of a mission to fully realize all the advantages. The Mariner Mark II (MM II) series of future missions offers such an opportunity<sup>[4]</sup>. MM II will seek to achieve "Voyager Class Science" in deep space at "Low Cost" and is thus committed to efficiency.

The fact that AICS compression and coding can yield substantial performance gains is now well recognized. However, there has never been an analysis which assigned quantitative dollar values to these gains. Providing such an analysis is the primary purpose of this report. In particular, we will determine the value of AICS performance gains to Voyager Uranus/Neptune and Galileo and estimate the potential value of a **fully implemented AICS** to a typical MM II mission. The results conservatively project future mission value or savings on the order of **\$7-9.5 million per mission**.

## APPROACH

AICS data compression and coding can improve the effective data rate through both the spacecraft downlink and the Deep Space Network (DSN) ground communication network. Further, data compression can increase the effective size of on-board mass storage. Our approach to assigning a **value** to these improved capabilities is basically to determine **what it would have cost to do them by other means**.

We will accomplish this by the systematic steps noted below:

- Provide AICS background establishing technology readiness and realizable compression factors;
- Determine the realizable AICS "system performance gains" to the spacecraft downlink, DSN ground communications and on-board mass memory;
- Determine the **incremental costs** for providing improvements to these same system elements **by other means**;
- Combine the latter incremental element costs with the AICS performance gains to yield overall mission value estimates for Voyager Uranus/Neptune, Galileo and MM II.

## BACKGROUND AND AICS STATUS

### Actual Implementations

**Voyager.** The RS coding in Fig. 2 was incorporated on the Voyager spacecraft just prior to launch as a backup mode in the event of an X-band failure at the Saturn encounter. Fortunately, such a failure did not occur so that now the concatenated channel can be expected to be used at both Uranus (1986) and Neptune (1989), an originally unplanned scenario. In addition, a form of adaptive image (noiseless) compression, based on the original work in Refs. 5 and 6, will be programmed into the on-board computer. The latter algorithm and various modifications which may be feasible at the Neptune encounter are described in Ref. 7. An average image compression factor of  $\gamma = 3$  can be expected. Then, since non-imaging data compression was not added, we have for future reference

$$\begin{array}{ccc} \text{Voyager} & & \text{Voyager} \\ \text{Uranus/Neptune} & & \text{Uranus/Neptune} \\ \gamma = 3 & , & \zeta = 1 \end{array} \quad (1)$$

**Galileo.** The original baseline Galileo data/communication system appears as in Fig. 1. However, the spacecraft now incorporates the additional RS coding on the image portion of the data in conjunction with a more complex (than Voyager Uranus) data compression system called BARC<sup>[8]</sup>. The latter algorithm is a one-dimensional adaptation of RM2. It includes the original noiseless operating mode as well as a rate controlled mode which adaptively alters quantization along a line to assure that only a specified number of bits are used. The Galileo image compressor will be operated in this mode at a fixed rate of 3.24 bits/picture (b/p) element instead of the original 8 b/p. The non-imaging data path, including the Golay coding, was left untouched. Then for future reference:

$$\begin{array}{ccc} \text{Galileo} & & \text{Galileo} \\ \gamma = 2.5 & , & \zeta = 1 \end{array} \quad (2)$$

**Standards.** At this point there have been numerous implementations of the Reed-Solomon coder as well as extensive work in verifying all the performance characteristics of the concatenated channel (see Ref. 9 for a historical background). In fact the concatenated channel is heading for international standardization<sup>[10]</sup>.

**Other.** A technology transfer program between JPL/NASA and Dalmo Victor Corporation has resulted in a recent demonstration prototype of an RM2 compressor/decompressor<sup>[11]</sup>. This implementation is intended for application to freeway surveillance and military reconnaissance. However, it was implemented with the processor (Intel 8086) most likely to be space-qualified for the Mariner Mark II mission set. This provides the potential for a technology transfer back to the space program.

Additionally, the National Oceanic and Atmospheric Administration (NOAA) is in the process of implementing the original noiseless image compression algorithms in a weather satellite application<sup>[12]</sup>,

### **Image Science Value Studies**

Two separate science value studies investigated the impact of an RM2 based AICS<sup>[13]-[15]</sup>. In both cases imaging scientists concluded that full use of the user controllable adaptive features could yield improvements from 4 to 6:1. Since we will be specifically addressing MM II as a future mission which might use such capabilities, we have

$$\begin{aligned} & \text{MM II Potential} \\ \text{Average Image (RM2) Compression Factor} & = \gamma = 4 \text{ to } 6 . \end{aligned} \tag{3}$$

### **Instrument Compression Studies**

A current program investigating the potential achievable compression factors for non-imaging science instruments on MM II suggests a conservative

$$\begin{aligned} & \text{MM II Potential} \\ \text{Average Non-Imaging Compression Factor} & = \zeta = 2 \text{ to } 4 . \end{aligned} \tag{4}$$

## II. PERFORMANCE GAINS

This section will provide an analysis which determines the realizable AICS "system performance gains" to the spacecraft downlink, DSN ground communications, and on-board mass memory.

### MASS MEMORY IMPROVEMENT

The gains to mass memory are rather obvious. A given capacity of on-board memory is effectively increased by the **average compression factor** used to represent data during storage operations. We denote this gain factor by  $G_M$ .

#### Voyager Uranus/Neptune

Compression is used only on downlink operations so that the mass memory gain factor is

$$\begin{array}{l} \text{Voyager} \\ \text{Uranus/Neptune} = 1 . \\ G_M \end{array} \quad (5)$$

#### Galileo

In this case 2.5:1 compression is applied to imaging data during mass memory operations. However, considerable uncompressed non-imaging data is included in the total data stored so that the effective mass memory increase factor is reduced to

$$\begin{array}{l} \text{Galileo} \\ G_M = 2 . \end{array} \quad (6)$$

#### MM II

There is no need to constrain the application of compression to these future missions. However, we must make some assumptions about the relative quantities of non-imaging and imaging data. We will assume that non-imaging data constitutes 1/3 of all data being stored "before compression." Then using (3) and (4), a mass memory capacity  $C$  would be effectively increased:

from

$$(1/3C)(2) + (2/3C)(4) = 10/3C$$

to

$$(1/3C)(4) + (2/3C)(6) = 16/3C.$$

Then we take the mass memory gain factor to be

$$\text{MM II} \\ G_M \approx 3.3 \text{ to } 5.3. \quad (7)$$

Observe that  $G_M$  would be slightly larger if the initial percentage of non-imaging data were smaller since we have estimated  $\zeta < \gamma$  in (3) and (4). Since a 33% figure for non-imaging data is probably high, the gain factors in (7) should be viewed as conservative.

**Summary.** The mass memory gain factors as just derived are consolidated into Table 1. These represent performance gains of at least 5 to 7 dB.

Table 1. Mass Memory Gain Factors.

Gain Factor	Mission		
	Voyager Uranus/Neptune	Galileo	MM II
$G_M$	1	2	3.3 to 5.3
$\{G_M\}_{dB}$	0	3	5 to 7

## DOWNLINK IMPROVEMENTS<sup>[9]</sup>

This system impact is by far the most difficult to assess. We will first focus on the individual gains to non-imaging and imaging transmission paths and then treat the joint communication problem.

### Direct Improvements to Non-Imaging and Imaging

**Non-Imaging.** Figure 3 compares the **non-imaging** transmission paths provided by the Voyager/Galileo baseline system in Fig. 1 and that provided by AICS. As shown, the

non-imaging data in the baseline system is Golay coded so that two bits are transmitted over the convolutional channel for each real data bit. As depicted in Fig. 3 then,  $2R$  bits/s pass through the convolutional channel for each  $R$  bits/s of real data.

By comparison, the concatenated RS/convolutional channel of AICS can operate at roughly  $(0.38)(2R)$  bits/s and yield "virtually error-free" communication. No Golay coder is necessary so that all  $1.76R$  bits/s are available for non-imaging data. If the non-imaging data can be compressed by an average factor of  $\zeta$ , the effective data rate for non-imaging is  $1.76 \zeta R$  bits/s. Then we have

$$G_{NI} = \begin{matrix} \text{Improved AICS} \\ \text{downlink performance} \\ \text{factor for non-imaging} \end{matrix} = 1.76 \zeta \quad (8)$$

Observe that for Galileo, non-imaging communication was left unchanged. For this situation we have the special case where<sup>[16]</sup>

$$G_{NI} = \begin{matrix} \text{Galileo} \\ \text{downlink performance} \end{matrix} = 1.0 \quad (9)$$

which is like taking a compression factor of  $1/1.76$  in (8).

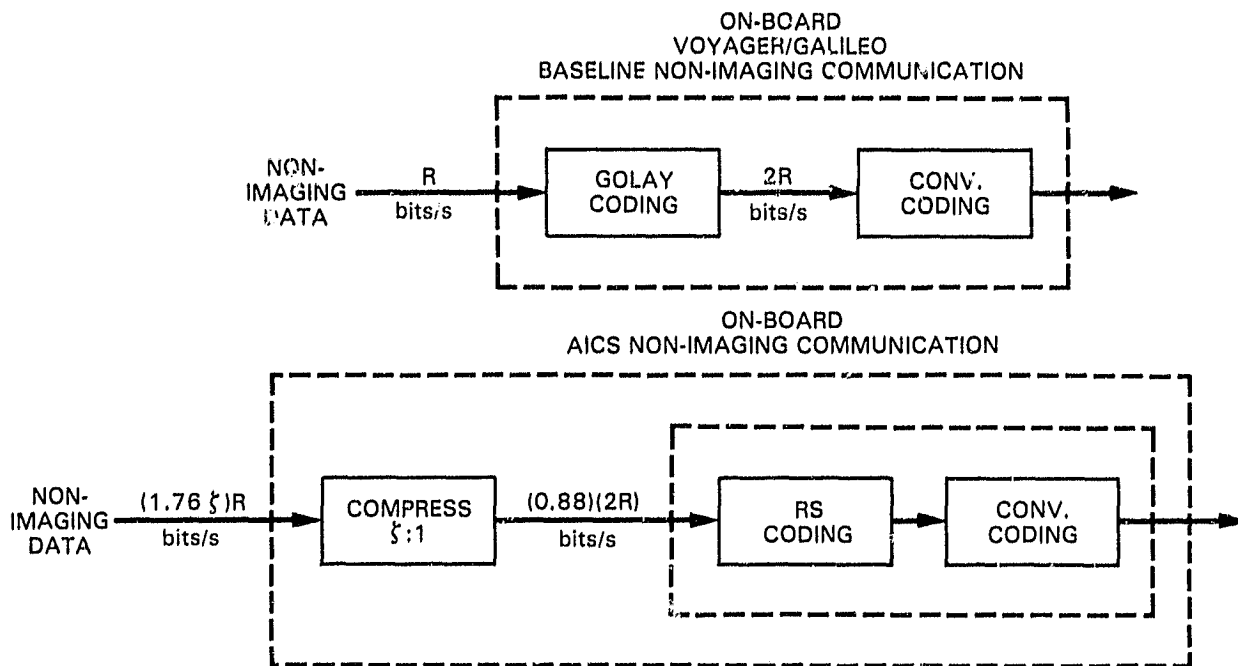

Fig. 3. Non-Imaging Architecture: Baseline vs. AICS.

**Imaging.** Figure 4 compares the on-board imaging transmission paths provided by the Voyager/Galileo baseline systems and that provided by AICS.

In the baseline system  $R$  bits/s of image data are directly passed through the convolutional channel. In AICS, compressed image data passes through the concatenated RS/convolutional channel at  $(0.88)R$  bits/s. Accounting for an average compression factor of  $\gamma$ , the effective imaging data rate is  $(0.88 \gamma)R$  bits/s. Thus we have the imaging data rate gain factor

$$G_I = \text{downlink performance factor for imaging} \approx 0.88 \gamma \quad (10)$$

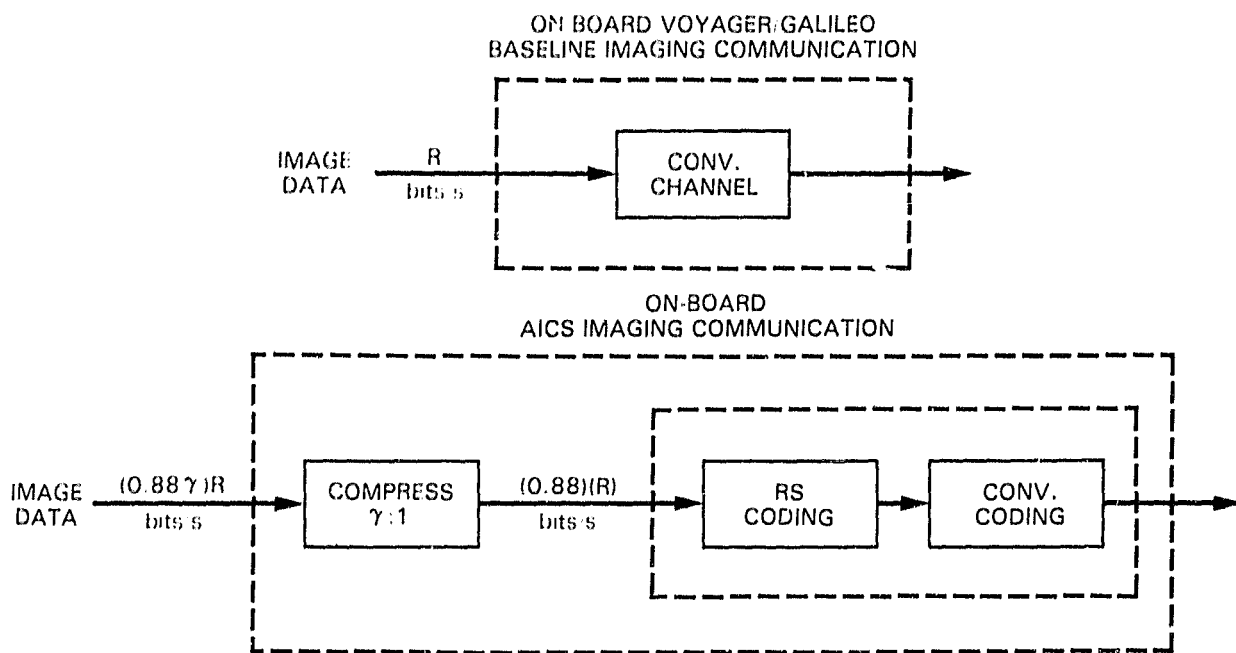

Fig. 4. Imaging Architecture: Baseline vs. AICS.

**Individual mission gain factors.** Now using (8), (9), and (10) we can establish the various gain factors for Voyager Uranus/Neptune, Galileo, and MM II. The results are given in Table 2.

### Overall Downlink Gains

In this report we are interested in the improvements to the total downlink data rates. To accomplish this we now need to treat the communication of non-imaging and imaging data jointly. This was done in Ref. 8 but the results are not in the form we will need for later value estimates.



Table 2. Individual Downlink Gain Factors.

Gain Factor	Mission		
	Voyager Uranus Neptune	Galileo	MM II
Non-Imaging $G_{NI}$	1.76	1.0	3.5 to 7
Imaging $G_I$	2.64	2.2	3.5 to 5.3

Figures 5 and 6 compare the baseline Voyager/Galileo systems and AICS by tracing the effects on data rate backwards from the convolutional channel which is assumed to operate in both cases at a rate of  $R_C$  bits/s.

The only new term is the multiplier  $\alpha$  which represents the fraction of available convolutional downlink rate,  $R_C$ , which is assigned to non-imaging data. Hence,  $1 - \alpha$  is the fraction assigned to imaging. The  $1/2$  term in Fig. 5 represents the data rate reduction factor caused by the 100% parity overhead of Golay coding. Correspondingly, the 0.88 term in Fig. 6 is the minor data rate reduction factor of the RS/convolutional channel in AICS.

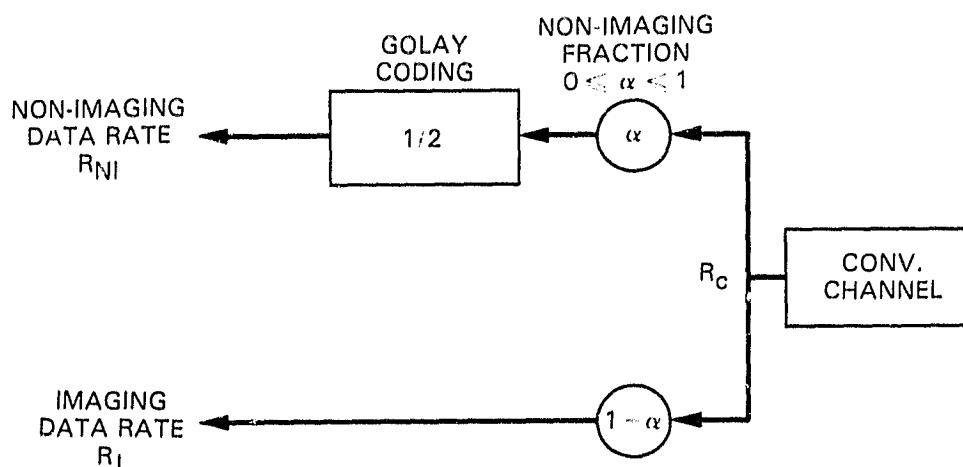

Fig. 5. Reverse Baseline Downlink Diagram.

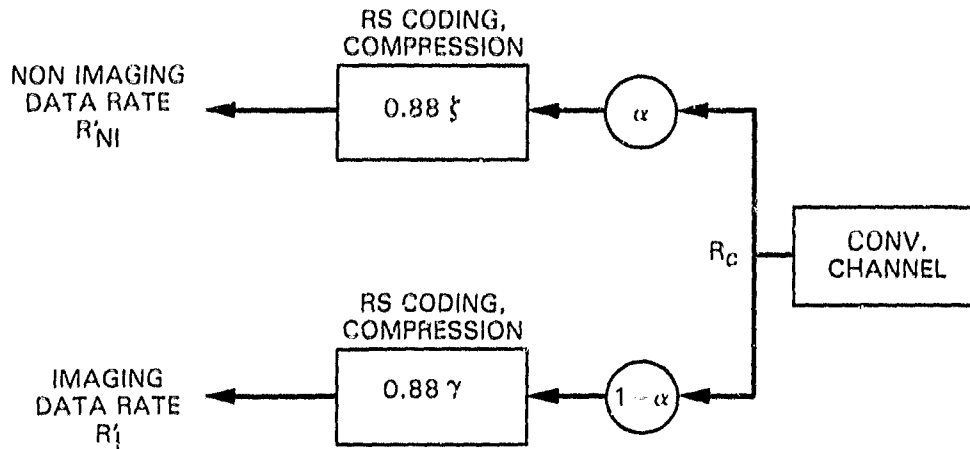

Fig. 6. Reverse AICS Downlink Diagram.

$R_{NI}$  and  $R'_{NI}$  represent the resulting net data rates available to non-imaging data in the two systems.  $R_I$  and  $R'_I$  represent the equivalent terms for imaging data.

Tracing through the diagrams we see that in the baseline

$$R_{NI} = \frac{\alpha}{2} R_C \text{ and } R_I = (1 - \alpha) R_C \quad (11)$$

for a total data rate of

$$R_T = \left[ \frac{\alpha}{2} + (1 - \alpha) \right] R_C \quad (12)$$

for AICS we have

$$R'_{NI} = 0.88 \zeta \alpha R_C \text{ and } R'_I = 0.88 \gamma (1 - \alpha) R_C \quad (13)$$

for a total available data rate of

$$R'_T = [0.88 \zeta \alpha + 0.88 \gamma (1 - \alpha)] R_C . \quad (14)$$

Rewriting these terms by using (8)–(10) we have

$$R'_T = \left[ \frac{\alpha G_{NI}}{2} + (1 - \alpha) G_I \right] R_C \quad (15)$$

which yields the overall downlink improvement factor achieved by AICS over the baseline as

$$G_D = \frac{\text{AICS Downlink Improvement Factor}}{R_T} = \frac{R_T}{R_T} = \frac{\alpha G_{NI} + 2(1 - \alpha) G_I}{2 - \alpha} \quad (16)$$

$G_D$  is the factor by which  $R_C$  would have to be increased in the baseline to achieve the same real data rate.

Now consider the special cases of interest in this paper.

**Voyager Uranus/Neptune.** The primary mode for the Uranus encounter (and Neptune with antenna arraying) will use an AICS downlink data rate of<sup>[17]</sup>

$$\begin{array}{l} \text{Voyager} \\ \text{Uranus} \\ R_C \end{array} = 14 \text{ kbits/s} \quad (17)$$

with 4 kbits/s of this assigned to non-imaging. Then we have

$$\begin{array}{l} \text{Voyager} \\ \text{Uranus/Neptune} \\ \alpha \end{array} = \frac{4}{14} = 0.285 \quad (18)$$

Then using Table 2 and Eq. 16 we get

$$\begin{array}{l} \text{Voyager} \\ \text{Uranus/Neptune} \\ G_D \end{array} = 2.49 \quad (19)$$

which represents a 3.8 dB gain in the overall downlink data rate.

**Galileo.** The primary communication mode on Galileo uses a convolutional channel transmission rate of<sup>[16]</sup>

$$\begin{array}{l} \text{Galileo} \\ R_C \end{array} = 115 \text{ kbits/s.} \quad (20)$$

The transmission rate assigned to non-imaging data (including some filler bits) is 22 kbits/s so that

$$\alpha_{\text{Galileo}} = 0.19 \quad (21)$$

Using Table 2 and Eq. 16 again we get

$$G_D^{\text{Galileo}} = 2.07 \quad (22)$$

which is slightly more than 3 dB.

**MM II.** From Table 2, the individual gain factors for imaging and non-imaging are very close with the estimated minimum gain factors the same. We can therefore bound the overall downlink performance gains by substituting the  $G_I$  range for  $G_{NI}$  on Eq. 16. After cancellation we get

$$G_D^{\text{MM II}} \geq G_I^{\text{MM II}} \approx 3.5 \text{ to } 5.3 \quad (23)$$

which represents an overall downlink performance gain of at least 5 to 7 dB.

**Summary.** The overall downlink gains provided by AICS to Voyager Uranus/ Neptune, Galileo and MM II are summarized in Table 3. For convenience later, Table 4 provides the nominal convolutional transmission rate  $R_C$ , including an estimated 30 kbits/s for MM II.

Table 3. Overall AICS Downlink Gains.

	Mission		
	Voyager Uranus/Neptune	Galileo	MM II
$G_D$	2.49	2.07	3.5 to 5.3
$\{G_D\}_{\text{dB}}$	3.8	3.0	5 to 7

Table 4. Convolutional Channel Downlink Rates.

	Mission		
	Voyager Uranus/Neptune	Galileo	MM II
$R_C$ kbits/s	14	115	30

## GROUNDLINK IMPROVEMENTS

Lets look more closely at the results that evolved from Figs. 5 and 6. At a convolutional channel rate of  $R_C$  the baseline system achieves only a real data rate given by (12) as

$$R_T = f(\alpha) R_C \quad (24)$$

where  $f(\alpha)$  is a function of  $\alpha$ . But by (16)

$$R_T = G_D R_T . \quad (25)$$

Comparing these we see that, with  $\alpha$  fixed,  $G_D$  is the factor by which the convolutional channel rate in the baseline would have to be increased to achieve the same real data rate  $R_T$ .

Now suppose that for both AICS and the baseline Voyager/Galileo systems the groundlink is merely an extension of the downlink. That is, all data received over the convolutional channel are passed on through the DSN ground communication network.

Then by the above arguments, the use of a baseline Voyager/Galileo downlink would require groundlink data rates to be  $G_D$  times higher than required if AICS were used.

Now note that for both Voyager and Galileo, the decoding of Golay coded non-imaging data is done at a central Mission Control and Computing Center (MCCC) at JPL. Thus all the data received on the convolutionally coded channel are passed on.

For AICS, there are also some advantages to placing the RS decoder at a central site. In such a case, all data received on the channel would be passed on. However, the

RS decoding may be done directly at the DSN stations so that RS parity would not need to be transmitted. In this case, a mission using the baseline Voyager/Galileo downlink would require groundlink data rates higher than AICS by  $\{G_D\}_{dB} + 0.6 \text{ dB}$ .

Ignoring this potential additional advantage, we can certainly say that

$$\begin{array}{ccc} \text{AICS} & & \text{AICS} \\ \text{Groundlink} & \geq & \text{Downlink} \\ \text{Gain Factor} & & \text{Gain Factor} \end{array} \quad (26)$$

and can thus use Tables 3 and 4 to assess any advantages to the ground communications.

### III. MISSION VALUE/COSTS

Achieving improved mission performance by increased "dBs" has been an on-going quest since the inception of the deep space program. Certainly, a comparison of the capabilities available for Mariner IV in 1964 and those available on the (baseline) Voyager and Galileo missions today is truly astounding. However, this achievement has pushed many areas of technology into maturity and efforts to improve their performance to a point of diminishing returns (e.g., doubling the size of the DSN 64-meter antennas is not a reasonable thing to consider). In essence, squeezing additional performance by standard approaches has become a costly endeavor.

As Tables 1 and 3 show, the coding and compression of AICS offer an alternative approach to obtaining significant performance gains. We wish to assign a value to those gains. To accomplish this we make fundamental use of the observation that the utilization of AICS components **generally avoids expenditures** that would have been necessary to achieve a desired level of performance by other means.

In essence, "we will assign a value to a particular AICS system gain equal to what it would have cost for such a gain by standard means."

Note that in using this approach we must deal with the fact that system performance improvements often come in steps which may be much larger than 1 dB. Certainly, any in-between gains must have a value. Then, to assign cost, and hence value, to performance improvements lying between and beyond these real discrete steps we will simply interpolate and extrapolate. For example, if it costs \$Y to double (3 dB) the mass memory from X bits to 2X bits, then we can assume the marginal cost for memory improvements is \$Y/3 per dB. The **value** of a  $\lambda$  dB improvement in mass memory (with a capacity in the vicinity of X bits) is then  $\$ \lambda Y/3$ .

Tables 1 and 3 give the AICS performance gains to mass memory, the downlink and, by (26), groundlink communication. It remains to determine the marginal costs associated with obtaining such gains by other means. Once established we can determine AICS mission value as

$$\text{Mission Value of AICS} = \sum_{\substack{\text{memory,} \\ \text{downlink,} \\ \text{groundlink}}} \left( \begin{array}{c} \text{AICS} \\ \text{dB Gain} \\ \text{System Element} \\ i \end{array} \right) \left( \begin{array}{c} \text{Cost/dB for} \\ \text{System Element} \\ i \\ \text{By Standard} \\ \text{Means} \end{array} \right) \quad (27)$$

## COST PER dB IMPROVEMENT BY STANDARD MEANS

### Basic Rule-of-Thumb Parameters<sup>[18]</sup>

The following provides a set of key rule-of-thumb costing parameters currently used in pre-project planning.

**On-board mass.** The basic cost of a kilogram of on-board mass is

$$\text{MASS\$} = \$100\text{K/kg} . \quad (28)$$

**Cost of RTG power.** A 250 watt Radioactive Thermoelectric Generator (RTG) costs \$13.75 million, leading to a direct incremental cost of

$$\text{DPOWER\$} = \frac{\text{Cost/watt}}{\text{on-board power}} = \$55\text{K/W} . \quad (29)$$

But such an RTG weighs 56 kg, leading to a secondary cost in spacecraft mass of

$$\text{RTGM} = \frac{\text{mass/watt}}{\text{on-board power}} = 0.22 \text{ kg/W} \quad (30)$$

or using (28), the indirect incremental cost for on-board power is

$$\text{IPOWER\$} = \$22\text{K/watt} . \quad (31)$$

Then, the total incremental cost for on-board power is given as

$$\text{POWER\$} = \text{DPOWER\$} + \text{IPOWER\$} = \$77\text{K/watt} \quad (32)$$

### Direct Costs for Increased On-Board Mass Memory

In the following discussions we will assume a baseline recording capacity,  $C$ , obtained from the use of a single off-the-shelf Voyager or Galileo tape recorder. This is still by far the cheapest flight qualified mass memory available.

**Basic assumptions.** A single Galileo or Voyager tape recorder costs \$1.7 million, with additional units costing roughly \$0.7 million. (33)



A development program to roughly double the capacity of such recorders by improving the packing density would cost about \$2.0 million.<sup>[19]</sup> (34)

On the other hand, a development program to ready other tape recorders (of higher capacity, say 4C) for JPL flight programs would cost around \$5 million<sup>[18]</sup>. (35)

The weight of a Galileo or Voyager recorder is around 9 kg. (36)

Power is dependent on rate of operation. At full rate these baseline recorders draw 20 watts. (37)

We will assume that any "developed" recorder has the same power and mass requirements and further, that the cost for subsequent recorders is the same as in (33). (38)

**Costs for the first 3 dB.** We could double the capacity to 2C by adding a second recorder or by modifying the existing recorders. Consider first the addition of a second recorder. By (33) this additional recorder would cost a **minimum** of \$0.7 million. If we assume that only one recorder operates at a time we do not have to account for extra power. However, from (36) and (28) the additional on-board mass would cost (9 kg) (\$100K/kg) = \$0.9 million. Adding these two terms gives

$$\begin{array}{l} \text{Cost of} \\ \text{Adding One} \approx \$1.6 \text{ million .} \\ \text{Recorder} \end{array} \quad (39)$$

This result is less than a development program to double the capacity of an existing recorder. Taking the smallest we get

$$\begin{array}{l} \text{Cost per dB} \\ \text{for Doubling} \geq \$533\text{K/dB.} \\ \text{Mass Memory} \end{array} \quad (40)$$

**Cost of 6 dB.** If we double the mass memory again, we would need either

- a) three standard recorders at a cost of \$4.8 million, or
- b) a new flight qualified recorder for about \$5 million, or
- c) two modified standard recorders at a cost of \$3.6 million (i.e., 2 + 1.6).

Taking the minimum option we get

$$\begin{aligned} & \text{Cost per dB} \\ & \text{for Quadrupling} \geq \$600\text{K} . \\ & \text{Mass Memory} \end{aligned} \tag{41}$$

**Costs per dB.** Taking the minimum of (40) and (41) we can bound the marginal cost for mass memory as

$$\begin{aligned} & \text{Cost per dB} \\ & \text{for} \geq \$533\text{K/dB} \\ & \text{Mass Memory} \end{aligned} \tag{42a}$$

and where

$$\begin{aligned} & \text{Cost per dB for} \\ & \text{Mass Memory} \approx \$600\text{K/dB} . \\ & \text{increase in the} \\ & \text{vicinity of 6 dB} \end{aligned} \tag{42b}$$

### Direct Costs for Increased Downlink Rates

Modifications for downlink transmission rate capabilities have historically been accomplished by altering basic communication system parameters: transmitter power, ground antenna gain and on-board antenna gain. We will first derive estimates for the individual costs associated with altering these parameters and then consolidate the latter results into an overall downlink per dB direct cost (= value).

**Transmitter power.** Doubling transmitter power will achieve a doubling of transmission rate capabilities. To compute the cost or "value" of this 3 dB gain, consider a transmitter power reference point of 10 watts. This corresponds to the MM II transmitter baseline.

Since the efficiency of such a transmitter is only 25%, the actual on-board power used by the 10 watt transmitter is 40 watts. Doubling this requires a 40 watt increment to on-board power (with a corresponding increment to spacecraft mass to support that power). Then using (32), this 3 dB gain in data rate would cost

$$(\$77\text{K/W})(40\text{W}) = \$3 \text{ million} . \tag{43}$$

Getting the next 3 dB would cost twice as much so, normalizing (43), we can lower bound cost by:

$$\begin{array}{l} \text{Cost per dB} \\ \text{By Changing} \geq \$1 \text{ million/dB} . \\ \text{Transmitter Power} \end{array} \quad (44)$$

The latter results are plotted in Fig. 7.

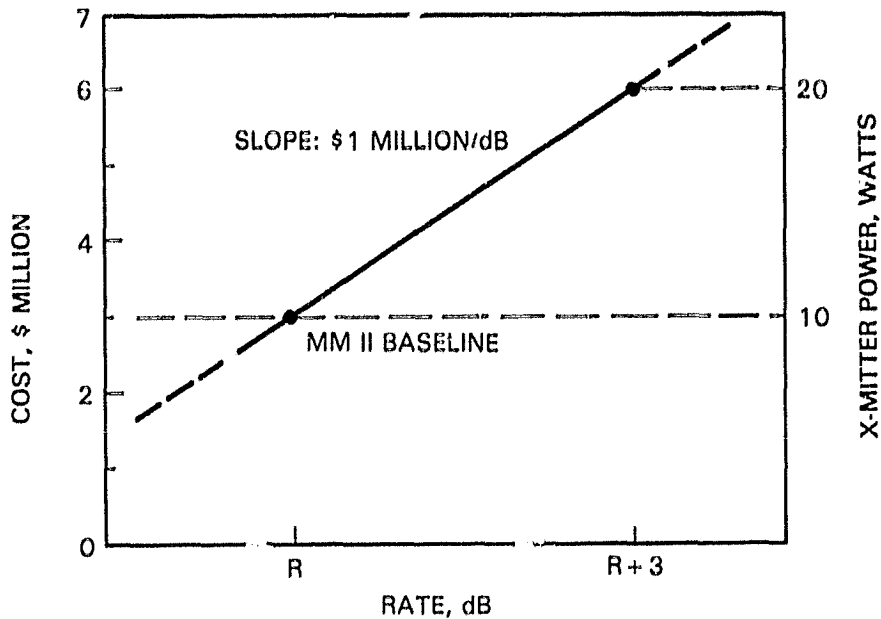

Fig. 7. Costs for dB Gain From Transmitter Power.

**DSN Stations.** The difference in performance between the DSN 34-meter (m) antennas and the 64-m antennas is about 5 dB. The difference in operational costs is substantial.

The stated charges for use of these stations<sup>[20]</sup> are \$2000/h for the 64-m stations and \$800/h for the 34-m stations. The difference between using one or the other is then

$$\begin{array}{l} \text{Hourly Cost Difference} \\ \text{Between 34-m and 64-m} = \$1200/\text{h} \\ \text{Stations} \end{array} \quad (45)$$

where

$$\begin{array}{l} \text{Data Rate} \\ \text{Advantage of} \\ \text{64-m over 34-m} \approx 5 \text{ dB} . \\ \text{Stations} \end{array} \quad (46)$$

These observations are plotted in Fig. 8. Observe that the slope of the line connecting the two options represents the hourly cost or value of a dB gain in data rate at the DSN stations. Then

$$\begin{aligned} \text{Hourly Cost} \\ \text{per dB} \\ \text{at the DSN} \end{aligned} \approx \$240/\text{h} \quad (47)$$

To determine mission cost we need an estimate of a typical number of hours of DSN use. Using MM II as a minimum guideline we assume 6 months of DSN tracking at 16 hours a day or 4 months of full use<sup>[21]</sup>. (The Voyager Uranus/Neptune and Galileo Jupiter orbiter missions could be longer.) Then using (47) we get<sup>†</sup>

$$\begin{aligned} \text{DSN Mission} \\ \text{Cost per dB gain} \\ \text{at the Stations} \end{aligned} = \$700\text{K}/\text{dB} . \quad (48)$$

These results are plotted in Fig. 9.

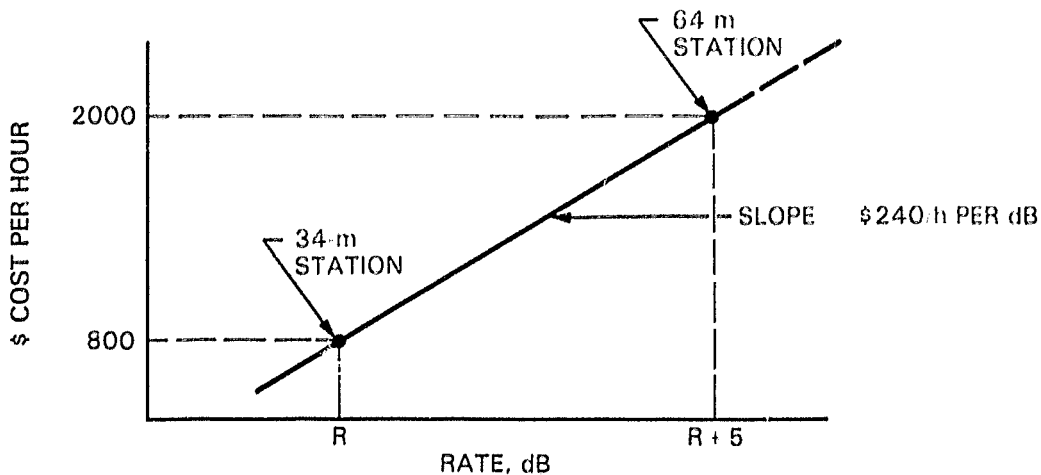
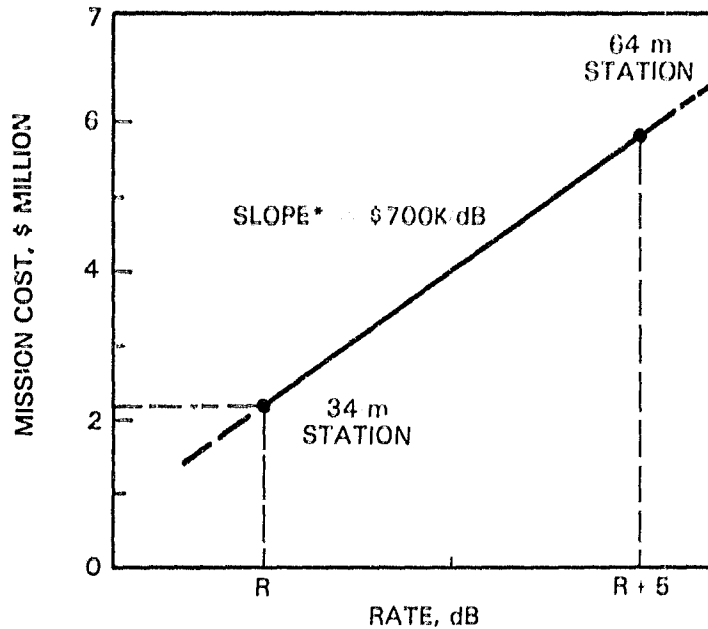

Fig. 8. The Hourly Cost of a dB at the Stations.

<sup>†</sup>This is quite conservative for the Galileo and Voyager Uranus/Neptune missions which may be considerably longer. In particular, the Galileo spacecraft should be collecting data for as long as two years.



\* ASSUMES 4 MONTHS OF FULL TRACKING

Fig. 9. Costs for dB Gain at the DSN.

**Increased antenna size.** [22] It is feasible to double the area of an off-the-shelf 1.4-m Viking antenna. However, going beyond this would become prohibitively expensive.

A doubling of area would increase transmission rate capability by 3 dB at a development cost of roughly \$ 750K. The estimated mass increase to provide the larger antenna is 6-8 kg or an additional cost of, using (28), \$ 700K. Then

$$\begin{aligned}
 &\text{Cost per dB} \\
 &\text{by Increasing} \\
 &\text{On-Board} \quad \approx \text{\$ } 500\text{K/dB} . \quad (49) \\
 &\text{Antenna Size} \\
 &\text{(first mission use)}
 \end{aligned}$$

**Consolidating downlink costs.** The performance improvements provided by increased transmitter power or higher gain antennas are additive. Each of them will separately add dB improvements to data rate capability. Then to assign a value to dB gains on the downlink we take an average of the incremental costs in (44), (48) and (49), yielding

$$\begin{aligned}
 &\text{Average Cost (value)} \\
 &\text{per dB improvement} \approx \text{\$ } 730\text{K/dB} . \quad (50) \\
 &\text{in Downlink Rate}
 \end{aligned}$$

In support of this approach, note that when Voyager implemented the RS coding before launch there was no time to build another antenna or increase on-board power. The only alternative for improving data rate was to improve the receiving antenna capability (by arraying antennas). The number assumed for DSN marginal cost in (48) is very close to the average in (50).

In the case of MM II, we are talking about dB gains of 5 to 7 dB. If we increase the downlink data rate performance on-board without AICS we must both increase transmitter power (3 dB) and antenna size (3 dB) to avoid using 64-m stations (5 dB). The average per dB cost for combining increases in transmitter power (\$1 million/dB) and antenna size (\$500K/dB) is \$750K/dB. If instead, this performance gain, say 5 dB, was obtained by using the 64-m stations then we are back to \$700K/dB. Either one is very close to the average in (50).

### Costs for Ground Communication<sup>[23]</sup>

Data received by DSN stations in Australia, Madrid and at Goldstone must be communicated back to a central Mission Control and Computing Center (MCCC) at JPL. We must look closely at the current communication structure to assign a fair value to increments in this "ground communication."

**Assumptions.** Communications rate capability between the DSN stations and JPL can now be increased in steps of 56 kbits/s or 224 kbits/s. All three stations must receive the same improvement.

The cost of each 56 kbits/s increment to performance differs for each station. Data from Australia travels first to Goddard Space Flight Center at \$35K/month and then to JPL via satellite at an additional \$4K/month. From Madrid the corresponding costs are \$16K/month and \$4K/month respectively. Goldstone costs are simply \$5K/month for each 56 kbits/s increment. Summing these costs we get

$$\begin{array}{r} \text{Cost for Each} \\ \text{56 kbits/s} \\ \text{Network Improvement} \end{array} \approx \$64\text{K/month} . \quad (51)$$

If as many as four additional 56 kbits/s lines are required, a single 224 bits/s capability can be added at lower cost:

$$\begin{array}{r} \text{Cost for Each} \\ 4 \times 56 \text{ kbits/s} \\ \text{Network Improvement} \end{array} \approx (3.5)(\$64\text{K}) = \$224\text{K/month} . \quad (52)$$

Most of the first 56 kbits/s capability is taken up in various forms of overhead so that only 5 kbits/s are available for transferring real mission data.

These observations are plotted in Fig. 10. Point A represents a network configuration employing a single 56 kbits/s line providing a mission usable 5 kbits/s. Such a basic capability can be viewed as always present.

Points B-E represent improvements to groundlink capability obtained by adding single 56 kbits/s lines one at a time. The slope of the dashed line connecting points A-E is then from (51)

$$\$1.14\text{K per kbits/s per month} . \tag{53}$$

Point F in Fig. 10 represents the same data rate capability as point E but is obtained at lower cost. The dashed line connecting point A and E is

$$\$1.0\text{K per kbits/s per month} . \tag{54}$$

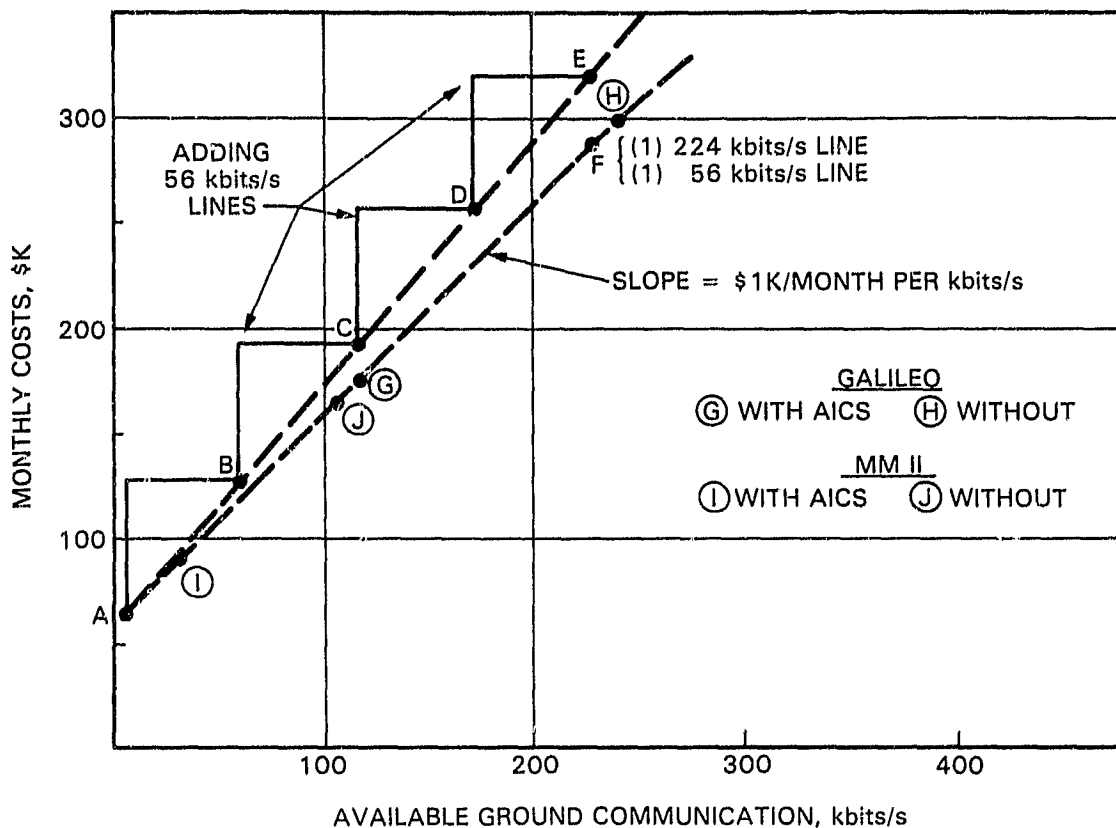

Fig. 10. Groundlink Costs.

Actual increments to performance can occur only in the steps indicated in Fig. 10 as A-B-C-D-E or A-F. However, such steps can result in a misleading interpretation of the value associated with a particular improvement in ground communication. For example, suppose the nominal groundlink communication requirement for a particular mission were 60 kbits/s. This is slightly less than the capability afforded by two 56 kbits/s lines at point B. An increase in data rate by only 0.1 dB would require moving to point C in Fig. 10 at a cost of \$640K per dB. This is not a fair assessment of the value of that added 0.1 dB.

More realistically we propose to assign values to ground communication improvements by **presuming** we could move along the dashed straight lines connecting the points A-E or A-F. To further assure a conservative estimate of value we will use the line A-F with its lesser slope given by (54).† (55)

**Voyager Uranus/Neptune value.** At both encounters the primary communication mode will utilize a downlink transmission rate of 14 kbits/s (Table 4). Using Table 3 we see that AICS makes this equivalent to  $(2.49)(14) = 35$  kbits/s. From Fig. 10 or (54) the incremental cost to go from 14 kbits/s to 35 kbits/s is

$$\begin{aligned} & \text{Voyager} \\ & \text{Uranus/Neptune} \\ & \text{Monthly} \approx \$21\text{K per month} . \\ & \text{Groundlink Cost} \\ & \text{for 3.8 dB Gain} \end{aligned} \tag{56}$$

**Assuming** 6 months of total DSN network operation for both encounters we get

$$\begin{aligned} & \text{Voyager} \\ & \text{Uranus/Neptune} \\ & \text{Groundlink Cost} \approx \$126\text{K} \\ & \text{for 3.8 dB Gain} \end{aligned} \tag{57}$$

or normalizing

---

† Observe that future DSN ground communication systems are expected to utilize time division-multiplexing. This will mean that each individual requirement for improvements to data rate could be **incrementally paid for at a kbits/s cost**. This is essentially what we are doing here in assigning "value."



$$\begin{array}{l}
 \text{Voyager} \\
 \text{Uranus/Neptune} \\
 \text{Incremental} \\
 \text{Groundlink Cost}
 \end{array}
 \approx \$33\text{K} . \quad (58)$$

**Galileo.** We have plotted the Galileo transmission operating points in Fig. 10. Point **(G)**, shown at 115 kbits/s, represents the now planned downlink operating point using AICS components. By Table 3, this rate would need to be  $(2.07)(115 \text{ kbits/s}) = 238 \text{ kbits/s}$  (point **(H)**) without AICS, to be equivalent. This increase of 123 kbits/s would, by (54), cost

$$\begin{array}{l}
 \text{Galileo Monthly} \\
 \text{Groundlink Cost} \\
 \text{for 3 dB Gain}
 \end{array}
 \approx \$123\text{K/month} . \quad (59)$$

Assuming 6 months of total DSN network support for this orbiter mission we get<sup>†</sup>

$$\begin{array}{l}
 \text{Galileo} \\
 \text{Groundlink Cost} \\
 \text{for 3 dB Gain}
 \end{array}
 \approx \$738\text{K} \quad (60)$$

or normalizing,

$$\begin{array}{l}
 \text{Galileo} \\
 \text{Incremental} \\
 \text{Groundlink Cost}
 \end{array}
 \approx \$246\text{K/dB} . \quad (61)$$

**MM II.** We take the nominal MM II downlink rate (with AICS) as 30 kbits/s, shown as point **(I)** in Fig. 10. By Table 3, the downlink would have to be at least  $(3.5)(30 \text{ kbits/s}) = 105 \text{ kbits/s}$  to be equivalent without AICS (point **(J)** in Fig. 10). This increase in transmission rate is valued at

$$\begin{array}{l}
 \text{MM II Monthly} \\
 \text{Groundlink Cost} \\
 \text{for 5 dB Gain}
 \end{array}
 \approx \$75\text{K/month} . \quad (62)$$

---

<sup>†</sup>Note again that this is quite conservative. The Galileo spacecraft should be collecting data for as long as two years.

Assuming 4 months of full DSN support this would cost

$$\begin{aligned} & \text{MM II} \\ & \text{Groundlink Cost} \approx \$300\text{K} \\ & \text{for 5 dB Gain} \end{aligned} \tag{63}$$

or normalizing,

$$\begin{aligned} & \text{MM II} \\ & \text{Incremental} \approx \$60\text{K/dB} . \\ & \text{Groundlink Cost} \end{aligned} \tag{64}$$

**Summary.** The groundlink costs just computed are costs (values) associated with increased groundlink data rates which would be needed if AICS were not present. By our previous arguments these costs are the values we assign to the AICS performance gains. They are summarized in Table 5 for convenience.

Table 5. Groundlink Values for AICS Performance Gains.

	Mission		
	Voyager Uranus/Neptune	Galileo	MM II
Mission Value \$K	126	738	300
per dB Value \$K	33	246	60

### OVERALL AICS MISSION VALUE

To obtain an overall mission value for AICS performance gains we need only substitute the appropriate terms into the "mission value equation", (27). Values associated with effective improvements to mass memory are easily determined from Table 1 and Eq. 42. Similarly downlink values can be computed using Table 3 and Eq. 50. Groundlink values were already computed directly and are summarized in Table 5.

The major quantitative results are shown in Table 6. The table lists the individual mission value contributions from improvements to a) mass memory, b) the downlink,

Table 6. AICS Mission Value.

	Mission		
	Voyager Uranus/Neptune	Galileo	MM II
Mass Memory \$ Million	0.0	2.01	3.0 to 4.2
Downlink \$ Million	2.77	2.19	3.65 to 5.11
Groundlink \$ Million	0.13	0.74	0.25
Mission Total Value	\$2.9 Million	\$4.94 Million	\$6.9 Million to \$9.5 Million

and c) ground communication along with cumulative mission value totals. Overall mission values of roughly **\$3 million for Voyager**, **\$5 million for Galileo** and **\$7 to \$9.5 million for an MM II mission** are shown.

Observe that the gains are potentially larger on MM II because it is the first mission set which might take full advantage of AICS. Observe that the incremental value to an investment in AICS performance in a single future mission is

$$\begin{aligned} & \text{Incremental} \\ & \text{AICS Value to } \approx \$1.4 \text{ million/dB .} \qquad (65) \\ & \text{MM II Mission} \end{aligned}$$

But over a five mission set the cumulative value might approach \$35 to \$50 million. The corresponding incremental value in seeking the maximum benefit from AICS then approaches **\$7 million/dB**, certainly a worthwhile investment.

Some of these multi-mission savings may have already been obtained. R. Stevens<sup>[24]</sup> notes that the existence of "effective" image data compression on-board the Voyager II spacecraft was the primary reason for cancelling the construction of four new 34-m antennas. These antennas, to be used to enhance the Voyager Uranus/Neptune encounters by arraying, would have cost \$5.6 million apiece. Thus AICS had a major role in saving over \$20 million in this one instance.

## AICS Costs

We now seek to arrive at the following conclusions:

- a) AICS implementation costs today are minor, relative to the dollar value contributed by the improved performance (Table 6).

and

- b) The costs to achieve a given level of AICS capability will diminish in the future.

Consider first the first order costs associated with today's AICS implementations on Voyager and Galileo.

**Voyager.** The RS encoder on Voyager for Uranus and Neptune was implemented over a 2-½ month development period just prior to launch. It used less than 100 low power CMOS chips, which will run at a low data rate (hence low power) of 14 kbits/s. The image data compression will be programmed into the existing on-board computer and thus incurs no additional spacecraft costs. Ground decoding and decompression could be done in software using existing facilities. Then without worrying about details, we can conclude that the AICS implementation costs on Voyager are negligible compared to the \$3 million value indicated in Table 6.

**Galileo.** The image compressor on Galileo has a much more difficult compression task and, along with the RS encoder, has to operate at much higher data rates.

The hardware compressor and RS encoder were built with CMOS logic over a 4-5 month crash effort by a single senior designer. One could certainly assume that the decompressor alone, a functionally simpler problem than the compressor, could be developed with less effort. In support of this, note that a ground decompressor can operate at rates much lower than the maximum required by the compressor (see below) and a ground decompressor design need not be constrained to use the limited set of flight qualified parts.

Reed-Solomon decoding is indeed a more difficult task than RS encoding. However, the subject of RS encoding/decoding has been absorbed into standardization programs and general long term DSN upgrade programs. By the time Galileo needs a high speed decoder there may exist a single decoder which can serve Galileo and all subsequent missions through the 1990s. Thus it is difficult to assign any specific cost to Galileo in particular.

Our first order approximation to real development costs for Galileo is to assume that ground development (decompressor and decoder) is roughly the same as the spacecraft development costs noted above. Summing these we have: the approximate AICS development costs for Galileo are equivalent to 4/5 man year of a senior designer's time.

Now consider the spacecraft costs. The compression/coder unit weighs 1.5 kg<sup>[25]</sup>, which by (28), incurs a spacecraft cost of \$150K. In addition, when image data is placed directly on the recorder, the compressor has to operate at 800 kbits/s. At such maximum operating rates the power requirements are 5 watts<sup>[25]</sup>. By (32) this would imply a spacecraft cost of (5W)(\$77K/W) → \$385K. But power use is a fairly direct function of data rate and the average mission data rate for compressed image data can certainly be no more than the downlink rate of 115 kbits/s. Thus the 5-watt maximum is probably too high a penalty to assign to the compressor. If we conservatively keep it, the first order spacecraft costs are 150 + 385 = \$535K.

Conservatively adding \$100K for 4/5 man years of development time we find that the **first order AICS costs on Galileo are close to an order of magnitude less than the mission value** shown in Table 6.

**Future missions.** By the above calculations, the costs associated with implementing AICS elements within Voyager and Galileo are minor compared with the net value obtained. An even stronger statement can be made for future missions.

Consider that AICS performance gains are basically derived from **processing** data differently than before. The real costs for AICS come from the hardware or software needed to accomplish this processing. Obviously, the tremendous advances in microelectronics are dramatically reducing the costs to accomplish any form of processing. In particular, the power, weight and volume and hence costs, associated with a **given level of AICS** capability today, in any part of the end-to-end system, will fairly **rapidly become negligible by comparison.**

Thus, the AICS implementation costs relative to performance values (Table 6) are already small and will continue to get smaller.

## REFERENCES

- (1) R. F. Rice, "Channel coding and data compression system considerations for efficient communication of planetary imaging data," **Technical Memorandum 33-695**. Jet Propulsion Laboratory, Pasadena, California, June 15, 1974.
- (2) R. F. Rice, "An advanced imaging communication system for planetary exploration," Vol. 66 **SPIE Seminar Proceedings**, Aug. 21-22, 1975, pp. 70-89.
- (3) AICS Patent 3988677, Oct. 26, 1976.
- (4) M. Neugebauer, "Mariner Mark II and the exploration of the universe," **Science**, Vol. 219, Number 4584, Feb. 4, 1983, pp. 443-449.
- (5) R. F. Rice, "The Rice Machine," **JPL 900-408** (Internal Document). Jet Propulsion Laboratory, Pasadena, California, Sept. 1, 1970.
- (6) R. F. Rice, J. R. Plaunt, "Adaptive variable length coding for efficient compression of spacecraft television data," **IEEE Trans. Commun. Technol.**, Vol. COM-19, Part I, Dec. 1971, pp. 889-897.
- (7) R. F. Rice, J. Lee, "Some practical universal noiseless coding techniques, part II," **JPL Publication 83-17**. Jet Propulsion Laboratory, Pasadena, California, March 1, 1983.
- (8) R. F. Rice et al., "Block adaptive rate controlled image data compression," **Proceedings of 1979 National Telecommunications Conference**, Washington, D.C., Nov. 1979.
- (9) R. F. Rice, "End-to-end imaging information rate advantages of various alternative communication systems," **JPL Publication 82-61**. Jet Propulsion Laboratory, Pasadena, California, Sept. 1, 1982.
- (10) NASA/ESA Working Group, "Guidelines for data communication standards: telemetry channel coding," Issue-2, June 6, 1983.
- (11) B. Elson, "Vidcomp System Speeds Image Relay," **Aviation Week and Space Technology**, May 7, 1984, pp. 109-115.

- (12) R. F. Rice, A. Schlutsmeyer, "Software for universal noiseless coding," **Proceedings of the 1981 International Conference on Communications**, Denver, Colorado, June 1981.
- (13) J. Cutts and L. Lebofsky, "Evaluation of the RM2 image data compression technique for outer planet missions with the Pioneer spacecraft," submitted to Jet Propulsion Laboratory by Planetary Science Institute, Pasadena, California, Final Rep., Subcontract 945152, Nov. 1975.
- (14) R. Kraus, "Effects of data compression on cloud motion measurement in planetary images," submitted to Jet Propulsion Laboratory by the University of Wisconsin, Final Report, Subcontract 955856, June 1981.
- (15) J. Cutts, K. Blasius, B. Lewis, J. Helu', "Modular data transport system data compression evaluation," submitted to the Jet Propulsion Laboratory by the Planetary Science Institute, Pasadena, California, Final Report, Contract IC 708842, June 1980.
- (16) "Functional requirement: Galileo orbiter," **JPL GIL-3-280, Rev. B.** (Internal Document), Jet Propulsion Laboratory, Pasadena, California, Dec. 13, 1982.
- (17) D. Acord, private communication.
- (18) R. Draper, private communication.
- (19) C. Wong, private communication.
- (20) R. Amorose, private communication.
- (21) M. Jones, private communication.
- (22) B. Meerhead, private communication.
- (23) R. Evans, private communication.
- (24) R. Stevens, "Implementation of large antennas for deep space mission support," **TDA Progress Report 42-76.** Jet Propulsion Laboratory, Pasadena, California, Oct.-Dec. 1983, pp. 161-169.
- (25) D. Johnson, private communication.