

General Disclaimer

One or more of the Following Statements may affect this Document

- This document has been reproduced from the best copy furnished by the organizational source. It is being released in the interest of making available as much information as possible.
- This document may contain data, which exceeds the sheet parameters. It was furnished in this condition by the organizational source and is the best copy available.
- This document may contain tone-on-tone or color graphs, charts and/or pictures, which have been reproduced in black and white.
- This document is paginated as submitted by the original source.
- Portions of this document are not fully legible due to the historical nature of some of the material. However, it is the best reproduction available from the original submission.

NASA
Technical
Memorandum

NASA TM -86482

THE VARIABLE POLARITY PLASMA ARC WELDING
PROCESS: ITS APPLICATION TO THE SPACE
SHUTTLE EXTERNAL TANK - SECOND INTERIM
REPORT

By A. C. Nunes, Jr., E. O. Bayless, Jr.,
and W. A. Wilson

Materials and Processes Laboratory

(NASA-TM-86482) THE VARIABLE POLARITY
PLASMA ARC WELDING PROCESS: ITS APPLICATION
TO THE SPACE SHUTTLE EXTERNAL TANK Interim
Report (NASA) 23 p HC A02/MF A01 CSCL 13H

N85-14115

Unclas
11464

G3/37

November 1984



National Aeronautics and
Space Administration

George C. Marshall Space Flight Center

1. REPORT NO. NASA TM- 86482		2. GOVERNMENT ACCESSION NO.		3. RECIPIENT'S CATALOG NO.	
4. TITLE AND SUBTITLE The Variable Polarity Plasma Arc Welding Process: Its Application to the Space Shuttle External Tank – Second Interim Report				5. REPORT DATE November 1984	
				6. PERFORMING ORGANIZATION CODE	
7. AUTHOR(S) A. C. Nunes, Jr., E. O. Bayless, Jr., and W. A. Wilson				8. PERFORMING ORGANIZATION REPORT #	
9. PERFORMING ORGANIZATION NAME AND ADDRESS George C. Marshall Space Flight Center Marshall Space Flight Center, Alabama 35812				10. WORK UNIT, NO.	
				11. CONTRACT OR GRANT NO.	
				13. TYPE OF REPORT & PERIOD COVERED Technical Memorandum	
12. SPONSORING AGENCY NAME AND ADDRESS National Aeronautics and Space Administration Washington, D.C. 20546				14. SPONSORING AGENCY CODE	
15. SUPPLEMENTARY NOTES Prepared by Materials and Processes Laboratory, Science and Engineering Directorate.					
16. ABSTRACT This report describes progress in the implementation of the Variable Polarity Plasma Arc Welding (VPPAW) process at the External Tank (ET) assembly facility. Design allowable data has been developed for thicknesses up to 1.00 in. More than 24,000 in. of welding on liquid oxygen and liquid hydrogen cylinders has been made without an internal defect.					
17. KEY WORDS Variable Polarity Plasma Arc Welding Gaseous Contaminants			18. DISTRIBUTION STATEMENT Unclassified – Unlimited		
19. SECURITY CLASSIF. (of this report) Unclassified		20. SECURITY CLASSIF. (of this page) Unclassified		21. NO. OF PAGES 21	22. PRICE NTIS

ACKNOWLEDGMENTS

Many people had significant roles in the development of Variable Polarity Plasma Arc Welding for application to the Space Shuttle External Tank.

Personnel in the Advanced Manufacturing Technology Laboratory, Materials Engineering, and Fabrication and Tank Production of Martin Marietta Corporation's Michoud Assembly Facility in New Orleans, Louisiana, who contributed significantly to the effort were D. Bolstad, C. Brosemer, T. Hibbard, R. Johnson, L. Johnston, W. McGee, S. Moutoux, W. Randolph, J. Radcliffe, J. Sexton, C. Thornburg, and all those who supported their efforts.

Personnel in the Metals Processes and Metallurgy Research Branches at Marshall Space Flight Center, Huntsville, Alabama, who contributed significantly to the effort were S. Clark, T. Craig, G. DeRamus, Jr., J. Hodo, N. Tiller, and all those who supported their efforts.

In the course of so extensive an effort, it is possible that a deserving contributor's name may have been overlooked. The acknowledgment listings must therefore not be taken as exclusive. To all contributors, the authors offer their thanks.

TABLE OF CONTENTS

	Page
INTRODUCTION	1
The Variable Polarity Plasma Arc Welding Process	1
Advantages of Straight, Reverse, and Variable Polarity	2
Origin of the Variable Polarity Plasma Arc Welding Program at Marshall Space Flight Center	2
MODIFICATIONS AND DEVELOPMENT OF THE EQUIPMENT	3
Computer Controls	3
Electromagnetic Interference Reduction	3
PROGRESS	4
VPPA Development Program Pathfinder Projects	4
Longitudinal Weld Pathfinder Project	4
Circumferential Weld Pathfinder Project	5
VPPA IMPLEMENTATION AT MAF	5
5015 Implementation Chronology	5
0.650 in. Allowables Development and Production Welds on 5015 Weld Tool	7
Implementation on 5017 Tool	7
Implementation on 5014 Tool	7
DESIGN ALLOWABLES TEST PROGRAM	10
Design Allowables Definitions	10
0.800 in. Allowables Development	10
1.00 in. Allowables Development	15
MSFC VPPA TORCH DEVELOPMENT	15
TECHNOLOGY EXCHANGE	17
CONCLUSION	17

LIST OF ILLUSTRATIONS

Figure	Title	Page
1.	Plasma arc, keyhole mode	1
2.	Pathfinder families	4
3.	Large horizontal VPPA weld development tool.	6
4.	0.650 in. joint design.	10
5.	J-groove weld joint configuration for 1.00 in. thickness	15
6.	Commercial torch	16
7.	MSFC developed torch (original concept).	16

LIST OF TABLES

Table	Title	Page
1.	Weld Tool Certification Data.	8
2.	VPPA Allowables Program as Welded Data	11
3.	VPPA Allowables Program Mismatch Data – X-Basis (KSI)	12
4.	VPPA Allowables Program Peaking Data.	13
5.	VPPA Allowables Program Mismatch Data – A-Basis (KSI)	14

TECHNICAL MEMORANDUM

THE VARIABLE POLARITY PLASMA ARC WELDING PROCESS: ITS APPLICATION TO THE SPACE SHUTTLE EXTERNAL TANK -- SECOND INTERIM REPORT

INTRODUCTION

The Variable Polarity Plasma Arc Welding Process

This report documents the development of a variable polarity plasma arc (VPPA) welding system and its application to the fabrication of the Space Shuttle external tank (ET) as carried out at NASA's Marshall Space Flight Center and at Martin Marietta Corporation's Michoud Facility.

Standard plasma arc welding, though used effectively on many other metals, had not been practical on aluminum alloys until the incorporation of the variable polarity characteristic. VPPA welding brings the advantages of the plasma arc to the welding of aluminum alloys.

Plasma arc welding (PAW) permits operation in the "keyholing" mode, where the plasma penetrates through the entire workpiece; the hole through the workpiece is opened by the plasma jet and seals up behind it to leave a deep, relatively narrow weld bead. Therein lies one principal advantage of the plasma arc process: its capacity for doing in a single pass what would require multiple GTAW passes.

An open keyhole allows escape of gaseous contaminants. Relative to GTAW, shorter paths for escape of such contaminants through thinner layers of molten metal lining the keyhole may also be significant. The plasma jet has been observed to blow out solid contaminants upon some occasions. The greater tolerance for contamination exhibited by the PAW process eliminates the need for the scraping procedure and for white glove handling of the aluminum required by the GTAW process.

An additional benefit of keyhole mode welding operations is derived from the narrow, relatively straight, weld cross section. This configuration (Fig. 1), as opposed to the normal more conical shape, tends to minimize peaking distortion of the weld.

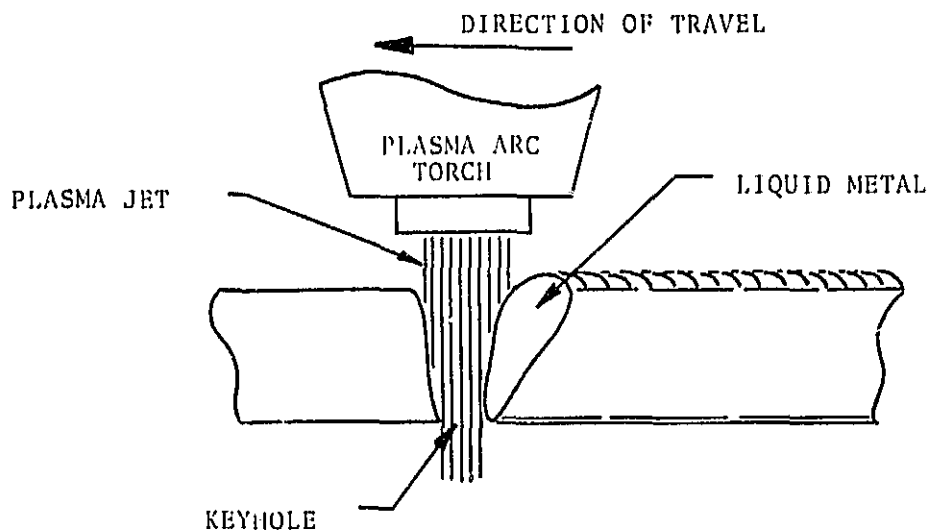

Figure 1. Plasma arc, keyhole mode.

Advantages of Straight, Reverse, and Variable Polarity

The significant current carriers in a welding arc are electrons and positive ions. Electrons carry the bulk of the current, moving rapidly from negative cathode to positive anode. The positive ions drift more slowly through the interelectrode space. The asymmetrical carrier flow results in differential heating at the ends of the welding arc in a fixed polarity arrangement. The cathode receives less heat and the anode more heat. The "straight polarity" mode of operation entails a negative electrode (cathode) and a positive work piece (anode). Where the primary object of the weld process is to deliver the maximum heat to the workpiece with minimal deterioration of the electrode, straight polarity is used.

"Reverse polarity," i.e., positive electrode and negative workpiece, has the advantage that the workpiece is subjected to a cleaning process, "cathodic cleaning," by the impingement of heavy (compared to electrons) positive ions on the workpiece surface. In the case of Plasma Arc Weld (PAW) reverse polarity action appears to condition the surface of the aluminum alloy so that the molten metal flows easily and controllably under the arc.

A variable polarity square-wave with unequal straight and reverse polarity times offers a combination of the high heating capability of straight polarity with the cleaning feature of reverse polarity. Adequate cleaning is obtained by incorporating a relatively short (one-tenth to one-fifth the duration of the straight polarity current) pulse of reverse polarity current into the welding current waveform.

Origin of the Variable Polarity Plasma Arc Welding Program at Marshall Space Flight Center

MSFC's first VPPA system was received in January 1979. It centered around a Hobart 400 A plasma torch, mounted on a Progressive Welder and Machine Co. (Pontiac, Michigan) manipulator. Power was supplied by a Hobart Alternate Polarity Cyber-Tig II power supply with an 800 High Pulse Series Programmer. Coolant and torch gas flow were controlled by an HPW-400 Plasma Control Console. Torch to work distance was controlled manually.

After a 6-month study it was concluded that:

- 1) VPPA welds in aluminum were essentially porosity free as noted by radiography. This characteristic would reduce weld repair costs appreciably with respect to GTA welds.
- 2) The cleaning of faying surfaces by scraping and the draw filing of adjacent surfaces of the joint as required for straight polarity GTA welding could be eliminated. This would reduce joint preparation costs appreciably with respect to GTA welds.
- 3) A significant reduction in peaking was noticed. This would reduce depeaking costs. Depeaking, usually done by magnetic hammer, is required on GTA welds where peaking, measured as the dihedral angle across the weld, exceeds 6.5 deg.

These conclusions were so encouraging that the decision was made to develop a production VPPA system to partially replace the GTAW system then used to fabricate the Space Shuttle ET, with its 36,000 in. of welds over thicknesses ranging from 0.140 to 1.040 in.

MODIFICATIONS AND DEVELOPMENT OF THE EQUIPMENT

Computer Controls

Because the wall thickness of the tank shell varies (e.g., the liquid oxygen tank nose section varies in thickness at the weld joints from 0.140 to 0.367 in. and the liquid hydrogen tank varies in thickness from 0.140 to 1.00 in.) tapered longitudinal and circumferential welds are frequently encountered. A computer to control welding parameters is required. Tapered welds require too high a level of skill and attention to be practical as manual welds in a production environment.

Therefore, in October 1979 a request for proposal to modify the then existing VPPA system by the addition of a digital program controller was issued, and in March 1980, Hobart Brothers, Inc., entered into a contract to carry out the task. In December 1980 a computer controlled VPPA system was delivered to Marshall Space Flight Center. A second computerized VPPA welding system was delivered to the ET fabrication plant of Martin Marietta at Michoud, Louisiana, in March 1981.

The heart of the computerized VPPA welding system is the PAL-100 computer, operating with a Digital Equipment Corp. (DEC) LSI-11/23 microprocessor. The computer sets weld parameters in accordance with set point inputs by the welding engineer. The computer can vary the parameters to produce tapered welds. A modification of the system, closing the control loop on the weld parameters, permits the system to continuously force measured parameters to coincide with desired set points. This has decreased the sensitivity of the system to variations in calibration.

The entire VPPA system, including the manipulator and cold wire feeder as well as the torch control and power supply, is computer controlled. Digital displays are used throughout the system.

Initial experience with this system has been good. The system has functioned according to design and has been convenient to use. Thus far, about a dozen weld programs have been recorded on production welds. There is no limit to the size of the weld program library which might be recorded. Memory capacity has been increased through replacement of the floppy disc memory with a hard disc memory.

Electromagnetic Interference Reduction

Due to the transients inherent in the switching of currents as large as the weld currents encountered in VPPA, electromagnetic interference (EMI) is a problem.

Prior to taking corrective measures, there was noise in the intercommunication system, flickering of the computer video monitor, counting errors in the weld length encoder, and it was impossible to operate a video camera in the area during welding. The following corrective measures were taken:

- 1) Welding power cables were wound into a "twisted pair" configuration for their full length.
- 2) Power leads and signal leads were separated where possible.
- 3) On the encoder, 0.02 microfarad capacitors were connected from the 0 deg and 90 deg signal leads to common.
- 4) The welding power cabinet and welding control cabinet were physically located farther apart.

5) The shield gas control valve signal was modified to originate at the weld head rather than the control room.

All EMI problems were eliminated or reduced to acceptable levels.

PROGRESS

VPPA Development Program Pathfinder Projects

Since the previous Interim Report, a major effort in the VPPA development program for Space Shuttle External Tanks has been the implementation of the VPPA welding system at MAF. This is being accomplished under a "Pathfinder" concept wherein a family of similar weld tools is qualified by a representative tool, called the Pathfinder.

Longitudinal Weld Pathfinder Project

The Pathfinder for longitudinal welds on the ET was the 5015 tool which produces welds via a horizontally held torch traveling vertically up along a fixed tank surface (Fig. 2). This family of tools includes the 5014 and 5017 tools. As of July 1984 all tools were on-line and producing ET components using VPPA.

As of late July 1984, Space Shuttle External Tanks LW-15 through LW-23 had been welded on the 5015 tool, for a total of over 24,000 inches of weld with no discernible internal defects.

GROUP IDENT.	TOOL NO.	CONFIGURATION DESCRIPTION	TORCH/TOOL/HARDWARE RELATIONSHIP
A	T04A5015 (PATHFINDER TOOL) •PROVES PROCESS FOR: T03A5014 T04A5017	•STATIONARY, VERTICAL WELD JOINT •HORIZONTAL TORCH TRAVEL BOTTOM TO TOP	
B	T05A5019 (PATHFINDER TOOL) •PROVES PROCESS FOR: T05A5068 T05A5018	•CYLINDRICAL SHAPE WITH CIRCUMFERENTIAL WELD JOINT •PART ROTATES PAST FIXED TORCH AT 3:00 O'CLOCK POSITION	
C	T01A5087 (PATHFINDER TOOL) T01A5001 T01A5002 T01A5004 T03A5012	•STATIONARY DOME SHAPE AND WELD JOINT •MOVING TORCH WELD WITH ALTITUDE CHANGE FROM 0° TO 90°	

Figure 2. Pathfinder families.

Circumferential Weld Pathfinder Project

The 5019 tool (Fig. 2) produces circumferential tank barrel welds by rotating a prone barrel section down past a fixed, horizontally held torch. Pathfinder qualification of VPPA welding on 5019 and similar tools (5018 and 5068) is being accomplished on a special weld development tool at Marshall Space Flight Center (MSFC).

The Large Horizontal VPPA Weld Development tool (Fig. 3) is located in the Productivity Enhancement Facility, Building 4707, at MSFC. This device is used to simulate full scale welding and tooling processes on a pair of actual External Tank barrel sections with interconnecting Tee ring. At the time of this report, four girth welds have been completed. Of the four completed welds, no internal defects could be detected.

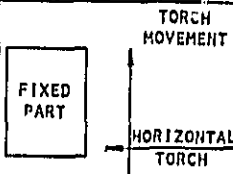
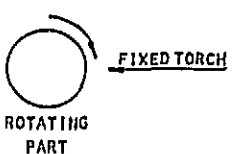
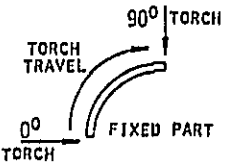
Weld schedules have been programmed and tested and made available for use at MAF.

An automatic peaking and mismatch measuring system has been designed by MMC and installed for use on upcoming girth welds five and six.

Future planned activities include the design of an automatic seam tracking system and installation of a fiber optic weld viewing system.

The 5019, 5018, and 5068 family of tools at MAF will use the VPPA weld schedules, close out techniques, and other improvements developed at MSFC, in the production of their pathfinder.

VPPA IMPLEMENTATION AT MAF

5015 Implementation Chronology

The VPPA welding system was moved out of Martin Marietta's Advanced Manufacturing Technology Laboratory on July 6, 1982. Installation of the torch, hot block, and PAL-100 computer began on July 6, 1982.

Early start-up problems included gas leaks at the torch requiring a complete rebuild with new O-rings. New connectors and verified lines were also installed. The weld schedules developed by both MSFC and MMC laboratories required modification due to additional heat sinking of the 5015 tool.

Interface problems were encountered in synchronization of the 5015 Sciaky travel and wire feed computer and the PAL-100 computer which controls current, volts, and gas feed. The synchronization of these computers was necessary to establish the precise taper point control and linearly scaled variables as required.

A-allowable parameters were used initially to determine the actual machine settings for producing acceptable 2 ft long weld test panels. An increase of 10 to 15 A of weld current was necessary to compensate for the increased heat sink capacity of the fixture.

The period August 1982 through May of 1983 was dedicated to system refinement, training, welding tests, and welding endurance tests. An attachment for revolving the torch was incorporated with resulting improvement of the plasma configuration. When the plasma gas becomes skewed, the torch is rotated to align it with the weld joint.

ORIGINAL PAGE IS
OF POOR QUALITY

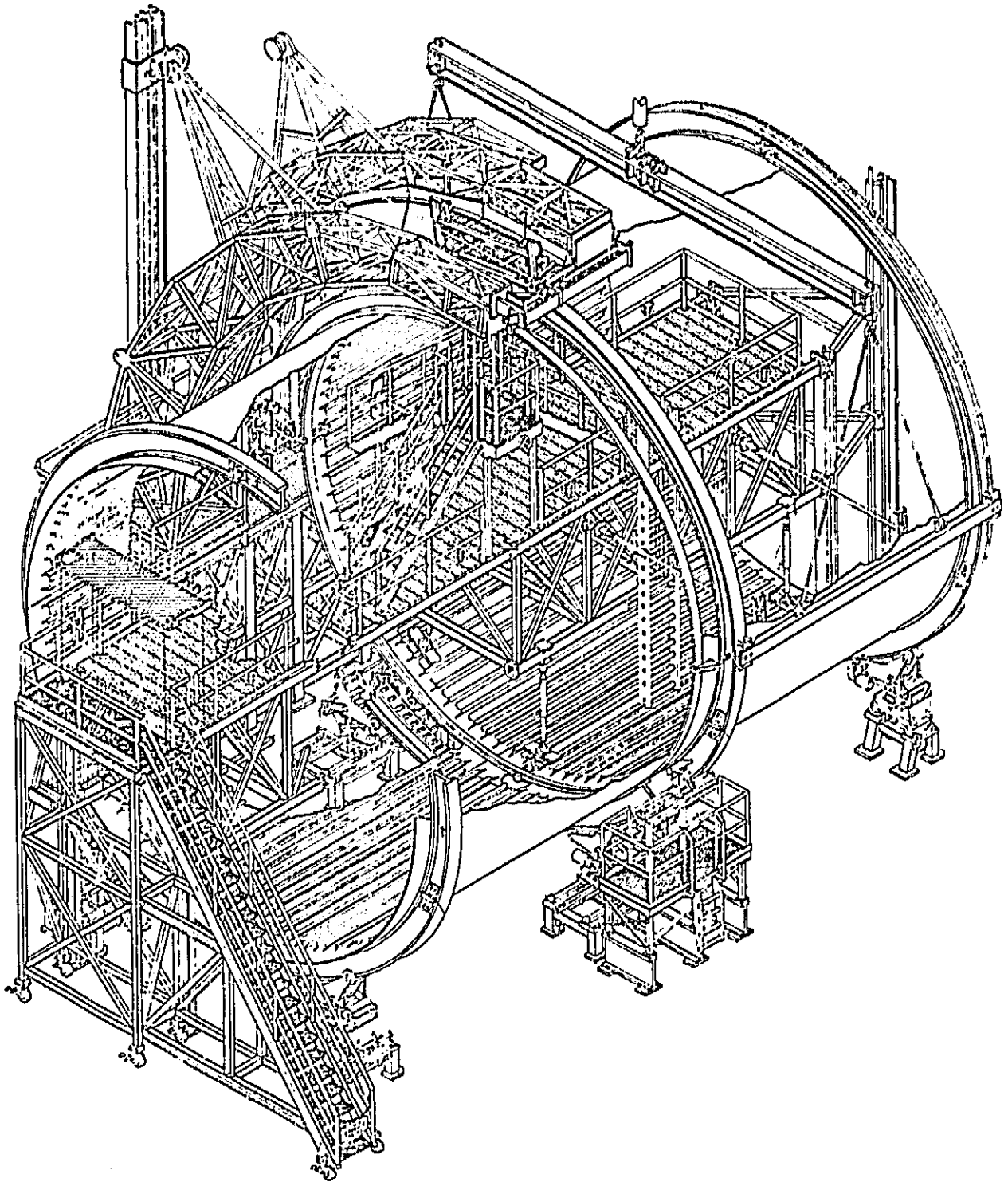

Figure 3. Large horizontal VPPA weld development tool.

Twenty-one test panels, 9 ft x 15 ft long, were VPPA welded on the 5015 tool between August 2 and September 2, 1983. Of these, only two had to be redone: one was a cold root pass due to operator error and the other due to a combination of cold root pass and malfunctioning electrode.

A supply of scrappe^d heavy weight external tank parts was available to permit the assembly of a cylindrical tank section. This was undertaken because the schedule allowed it and the exercise provided valuable training and experience to the welders and weld engineers. Upon completion of this task, the tank section was subjected to the normal x-ray, mismatch and peaking measurements, providing feed-back of the welding quality for operations and management evaluation.

The ultimate tensile strength of all test specimens obtained from the 15 ft welded panels were 2 to 3 KSI above the A-allowable laboratory test requirements. The improvement in weld strength was attributed to the cooling effect in the immediate vicinity of the weld on the 5015 tool.

In February 1983 the functional checkout of the system was completed. By mid-March, all 5015 weld tool certification had been completed (Table 1). This data has been incorporated into the MMC Welding Specification, STP 5506.

By mid-May, the first pathfinder component had been completed with no internal weld defects.

0.650 in. Allowables Development and Production Welds on 5015 Weld Tool

As of 1 August 1984, a total of more than 24,000 in. of VPPA weld had been completed with no discernible internal defects.

The 0.650 in. thickness welds on the 5015 tool are presently being welded using a J-groove configuration at the weld joint (Fig. 4). This weld is completed in three passes; one penetration, and two fill.

The barrel components for tanks through LW-32 have been configured with the J-groove and are on hand at MAF. Future panels will be machined with a square butt weld joint and will be welded in one penetration pass and a single fill pass.

Implementation on 5017 Tool

VPPA welding was implemented on the "T" ring welding tool (5017) in May of 1984. Four configurations of "T" rings are welded on this fixture, with welds varying in thickness from 0.370 in. to 0.800 in.

As of 1 August 1984 the first full set of Tee rings had been fabricated using VPPA welding, on the 5017 tool. This consists of four welds of 8 in. each on four rings, a total of 128 in. No discernible internal defects were detected.

Implementation on 5014 Tool

VPPA welding implementation was begun on the aft ogive welding tool (5017) on May 30, 1984. Low tensile strength failure of 0.375 in. welds was found to be caused by a combination of improper weld parameters and operator error.

TABLE 1. WELD TIGOL CERTIFICATION DATA

WELD THICKNESS	WELD PASS	ARC CURRENT	ARC VOLTS	TRAVEL IN./MIN.	WIRE IN./MIN.	SHIELD GAS (CFH)	PLASMA GAS (CFH)	TENSILE MAX (KSI)	TENSILE MIN. (KSI)
.320	1	233 (H)	29.6	9.2	50.0	50.0	5.8	42,349	39,419
	2	175	24.5	6.8	50.0	50.0	2.0		
.320	1	180 (N)	29.0	9.0	50.0	50.0	5.8	43,990	43,332
	2	175	24.5	6.8	15.0	50.0	2.0		
.320	1	165 (L)	29.4	9.1	50.0	50.0	5.8	42,713	41,925
	2	175	24.9	6.8	15.0	50.0	2.0		
.312/.387 (Taper)	1	240/215 (H)	30.0	8.0	55.0	60.0	5.5	43,909	39,441
	2	180/175	27.6	6.8	15.0	60.0	2.0		
.362/.387 (Taper)	1	210/195 (N)	30.0	8.0	55.0	60.0	5.5	44,453	42,801
	2	180/175	27.0	6.75	15.0	60.0	2.0		
.362/.387 (Taper)	1	190/170 (L)	30.0	8.0	55.0	60.0	5.5	44,641	42,694
	2	180/175	27.0	6.75	15.0	60.0	2.0		
.370	1	210 (H)	29.5	9.5	45.0	70.0	5.5	42,005	40,549
	2	165	25.0	7.0	25.0	70.0	2.5		
.370	1	200 (N)	29.5	9.5	45.0	70.0	5.5	40,877	39,774
	2	165	25.0	7.0	25.0	70.0	2.5		
.370	1	190 (L)	29.5	9.5	45.0	70.0	5.5	42,747	41,257
	2	165	25.0	7.0	25.0	70.0	2.5		
.450	1	235 (H)	30.5	9.0	40.0	70.0	5.5	41,417	38,273
	2	170	25.5	6.5	20.0	70.0	2.5		
.450	1	225 (N)	30.5	9.0	40.0	70.0	5.5	41,529	40,396
	2	170	25.5	6.5	20.0	70.0	2.5		
.450	1	215 (L)	30.5	9.0	40.0	70.0	5.5	41,986	41,112
	2	170	25.5	6.5	20.0	70.0	2.5		
.500	1	255 (H)	31.0	8.0	40.0	70.0	5.5	40,219	39,741
	2	175	25.5	7.0	20.0	70.0	2.5		
.500	1	245 (N)	31.0	8.0	40.0	60.0	5.5	40,879	39,770
	2	175	25.5	7.0	20.0	60.0	2.5		
.500	1	235 (L)	31.0	8.0	40.0	60.0	5.5	41,587	40,035
	2	175	26.5	7.0	20.0	60.0	2.5		

H = High
 N = Nominal
 L = Low

TABLE 1. (Concluded)

WELD THICKNESS	WELD PASS	ARC CURRENT	ARC VOLTS	TRAVEL IN./MIN.	WIRE IN./MIN.	SHIELD GAS (CFH)	PLASMA GAS (CFH)	TENSILE MAX (KSI)	TENSILE MIN. (KSI)
.550	1	250 (H)	32.0	5.5	65.0	59.0	5.4	43,179	40,252
	2	220	27.0	5.0	75.0	59.0	2.0		
.550	1	240 (N)	32.0	5.5	65.0	59.0	5.42	42,593	41,617
	2	220	27.0	5.0	75.0	59.0	2.0		
.550	1	225 (L)	32.0	5.5	65.0	59.0	5.4	43,171	40,809
	2	220	27.0	5.0	75.0	59.0	2.0		
.650	1	255 (H)	32.5	5.0	65.0	59.0	5.4	42,169	39,092
	2	220	27.0	5.0	75.0	59.0	2.0		
	3	230	26.5	5.0	65.0	59.0	2.0		
.650	1	245 (N)	32.5	5.0	65.0	60.0	5.5	42,680	42,096
	2	220	27.0	5.0	75.0	60.0	2.0		
	3	230	26.5	5.0	65.0	60.0	2.0		
.650	1	235 (L)	32.5	5.0	65.0	60.0	5.5	41,085	40,086
	2	220	27.0	5.0	75.0	60.0	2.0		
	3	230	26.5	5.0	65.0	60.0	2.0		
.800	1	265 (H)	32.0	4.5	45.0	70.0	5.5	40,096	37,425
	2	240	27.0	4.0	85.0	70.0	2.0		
	3	240	27.5	4.0	50.0	70.0	2.0		
.800	1	255 (N)	32.0	4.5	45.0	70.0	5.5	40,195	39,545
	2	240	27.0	4.0	85.0	70.0	2.0		
	3	240	27.5	4.0	50.0	70.0	2.0		
.800	1	250 (L)	32.0	4.5	45.0	70.0	5.5	40,377	39,345
	2	240	27.0	4.0	85.0	70.0	2.0		
	3	240	27.5	4.0	50.0	70.0	2.0		
1.000		NOT AVAILABLE*							

* TO BE INCLUDED IN NEXT REPORT

H = High
 N = Nominal
 L = Low

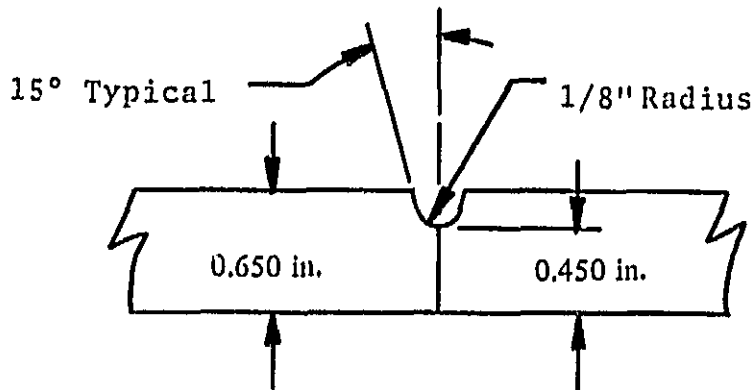

Figure 4. 0.650 in. joint design.

A macrographic cross sectional examination revealed misalignment of the cover pass, as well as inadequate cover pass width and depth.

Torch travel speed was reduced from 7.5 ipm to 5.0 ipm to increase the heat input per increment of weld and, with proper alignment, consistent tensile strength was attained.

In July of 1984, the first aft ogive section was completed with no internal weld defects.

DESIGN ALLOWABLES TEST PROGRAM

The design allowables test program is continuing. The first interim report contained allowables data for 0.125, 0.250, 0.375, and 0.500 in. thick 2219-T87 aluminum plate. Data for 0.650, 0.800, and 1.00 in. welds are complete (Tables 2 through 5). It should be noted that minor changes to accommodate groupings of sets into thickness ranges are possible, and the allowables should be considered as interim values.

During the verification of weld process variables and process implementation at MAF, it was noted that small variations in mechanical properties of welds existed. To understand the cause and effect of these variations, a study is required. This will be undertaken as funding is available.

Design Allowables Definitions

The \bar{X} basis data given in Tables 2 through 5 represent the mean value of the ultimate tensile strengths. The A basis values represent that value which at least 99 percent of the population of values will equal or exceed, with a confidence of 95 percent.

0.800 in. Allowables Development

The 0.800 in. allowables were welded using a square butt joint design. A penetration pass and one fill pass are required to complete the weld.

TABLE 2. VPPA ALLOWABLES PROGRAM AS WELDED DATA

t, in.	# PASSES	T°	n	\bar{X} -BASIS (KSI)	A-BASIS (KSI)	UTS REQMT
.125	1	RT	57	45.4	41.5	↑
		-320	20	57.3	52.0	
		-423	20	64.8	57.1	
.250	1	350	20	36.0	33.7	40 KSI Min Avg 38 KSI Min ↓
		RT	298	40.2	38.1	
		-320	20	54.3	50.0	
		-423	20	60.5	54.2	
.375	2	350	20	37.1	35.1	↓
		RT	50	41.7	39.7	
		-320	20	56.1	51.1	
		-423	20	63.4	53.4	
.500	2	RT	53	40.3	38.8	↑
		-320	20	49.3	46.7	
		-423	23	57.0	44.0	
.650	3	RT	50	40.6	37.9	↓
		-423	10	59.4	51.9	
.800	2	RT	50	38.9	36.8	38 KSI Min Avg 35 KSI Min
		-423	10	59.1	49.1	
1.00	2	RT -423	50	39.1	35.4	

TABLE 3. VPPA ALLOWABLES PROGRAM MISMATCH DATA - X-BASIS (KSI)

t, in.	# PASSES	T	MISMATCH (INCHES) - \bar{X} -BASIS (KSI)											
			.007	.010	.013	.015	.020	.030	.040	.050	.060	.070	.080	.100
.125	1	RT -320 -423	45.1		44.7		43.2	38.4 50.8 51.3	37.8			34.8		
.250	1	350 RT -320 -423		39.7		38.9	34.9 38.4 51.9 53.3	37.1	36.2		34.5	31.1		
.375	2	350 RT -320 -423					41.3	40.3	38.4		34.4 48.7 55.6	37.4	35.3	
.500	2	RT -320 -423					37.6	37.1	36.1		36.5 42.9 43.1	31.2		29.3
.650	3	RT -423					39.5		37.6			35.8 53.6		35.5
.800	2	RT -423					36.9		34.4			35.1 39.9		35.2
1.00	2	RT -423					37.3		35.6			33.4		32.0

TABLE 4. VPPA ALLOWABLES PROGRAM PEAKING DATA

t, in.	#PASSES	T°	DEGREE OF PEAKING - \bar{X} -BASIS (KSI)						DEGREE OF PEAKING - A-BASIS (KSI)					
			2°	4°	6°	7°	8°	10°	2°	4°	6°	7°	8°	10°
.125	1	RT -320 -423	43.9	43.4	42.0	57.1 46.8	36.1	40.2	38.6	39.8	35.7	43.5 29.6	21.9	32.2
.250	1	350 RT -320 -423	40.2	37.9	36.6		35.5	34.5			33.1			
.375	2	350 RT -320 -423	41.3	41.8	35.3 39.0 45.1 50.7		39.2	36.9	39.8	40.5	32.2 31.1 32.7 36.5		36.2	34.3
.500	2	RT -320 -423	37.0	36.1	36.7 46.6 52.3		34.6	34.0	32.0	33.4	34.0 33.6 41.5		31.8	27.7
.650	3	RT -423	---	39.7	39.2 59.8		38.5	---	---	38.1	37.4 54.6		35.9	---
.800	2	RT -423	---	38.4	36.3		37.0 45.8			35.6	32.2		34.6 29.7	
1.00	2	RT -423		39.5	38.5		37.7			35.6	36.5		36.6	

--- Not Required

TABLE 5. VPPA ALLOWABLES PROGRAM MISMATCH DATA - A-BASIS (KSI)

t, in.	# PASSES	T°	MISMATCH (INCHES) - A-BASIS (KSI)											
			.007	.010	.013	.015	.020	.030	.040	.050	.060	.070	.080	.100
.125	1	RT -320 -423	41.4		42.7		39.8	32.8 35.9 44.8	31.9			30.2		
.250	1	350 RT -320 -423		37.7		37.5	31.7 36.2 42.4 46.0	35.5	33.9		31.3	29.7		
.375	2	350 RT -320 -423					38.6	38.5	36.8		33.1 41.5 43.6	34.9	32.8	
.500	2	RT -320 -423					34.5	33.2	32.5		33.6 39.9 28.4	26.9		29.8
.650	3	RT -423					36.3		35.4		32.0 48.2			33.2
.800	2	RT -423					33.3		32.0		30.9 33.7			32.7
1.00	2	RT -423					29.8		32.1		23.6			27.9

During the development of the weld parameters, the helium shield gas flow rate became a problem. The flow rate for the 0.800 in. square butt had to be increased due to the volume of molten metal being carried in the penetration pass. The internal dimension of the torch between the plasma gas orifice and the shielding cup prevented adequate gas flow.

An 0.080 in. thick spacer was inserted between the back of the shield cup and the torch body to increase the clearance and allow increased shield gas flow. The plasma jet orifice diameter was also increased from 0.157 in. to 0.177 in.

1.00 in. Allowables Development

Considerable effort was expended attempting to weld the 1.00 in. thickness using a square butt joint design. Using 24 in. long test panels, it was possible to complete this weld configuration successfully in the laboratory; but the process required such precise control that it was considered too difficult to be attempted in a production environment. A modified J-groove was adopted (Fig. 5) and the allowables were developed for this configuration.

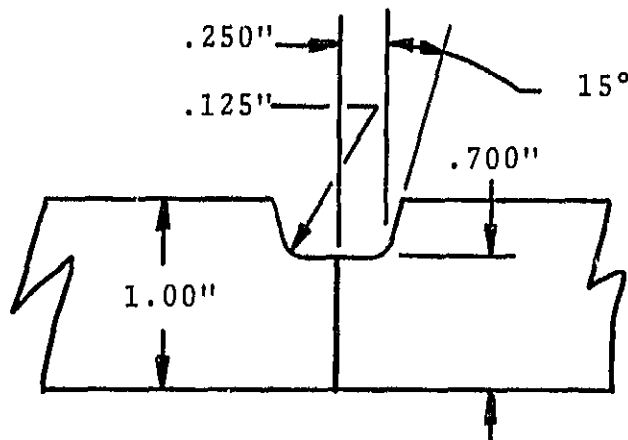

Figure 5. J-groove weld joint configuration for 1.00 in. thickness.

MSFC VPPA TORCH DEVELOPMENT

Early in the VPPA development program problems were encountered in the commercially designed welding torch. The commercial torch uses "O" rings throughout to maintain isolation of the liquid coolant, the plasma gas, and the shield gas (Fig. 6). The electrode requires precise centering and spacing adjustment which tends to deform the "O" rings and cause leaks.

A special set of tools was designed at MSFC to assist in the alignment and assembly of the commercial torch. Even with these tools, extensive training is required to properly assemble and service this torch.

Due to these difficulties, a development effort was initiated at MSFC to design and develop a hermetically sealed torch with a capability of self centering the electrode. The original torch is shown in Figure 7.

The MSFC torch, patent pending, has been certified by NASA/MSFC and is presently in the process of being released for use on all VPPA applications at MAF.

The new torch is hermetically sealed and has positive mechanical centering of the electrode. The cooling water capacity is increased and the plasma gas orifice is designed for greater heat transfer. This reduces the operating temperature and the associated thermal erosion of the plasma gas orifice. Two major advantages of the new torch are greatly reduced thermal erosion and simplified maintenance. Expendable components can now be replaced by unskilled personnel. The previous torch required a dedicated torch assembly facility, staffed by specially trained personnel.

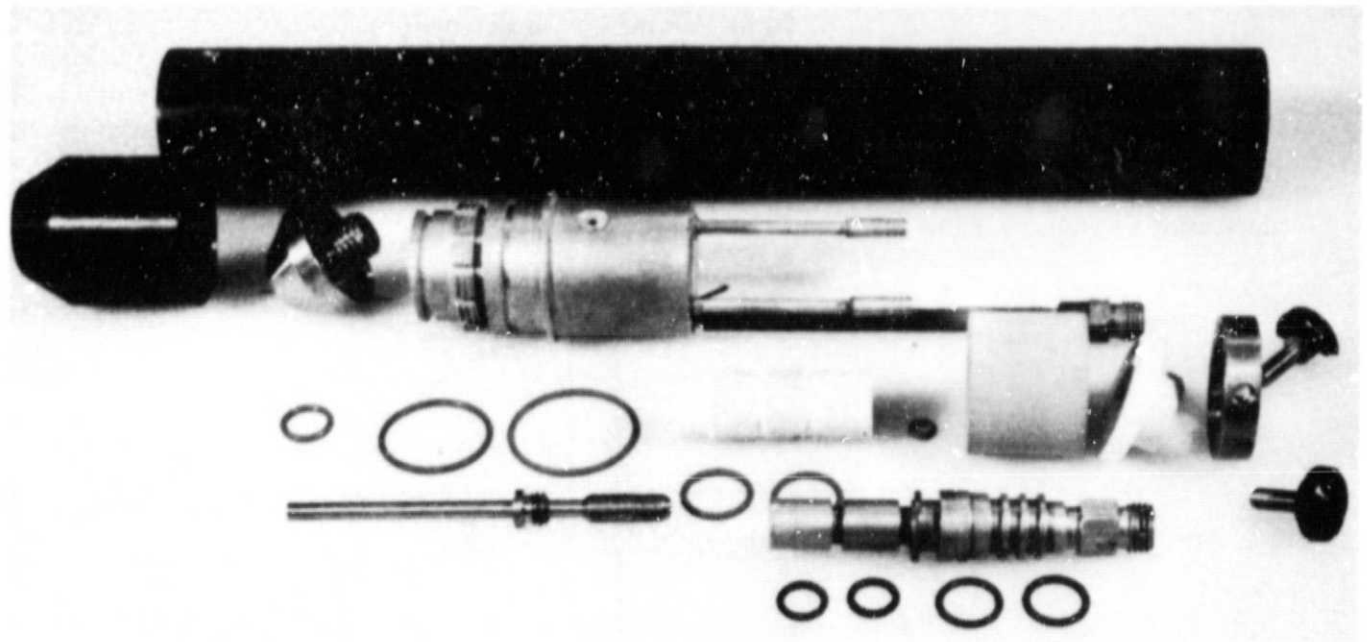

Figure 6. Commercial torch.

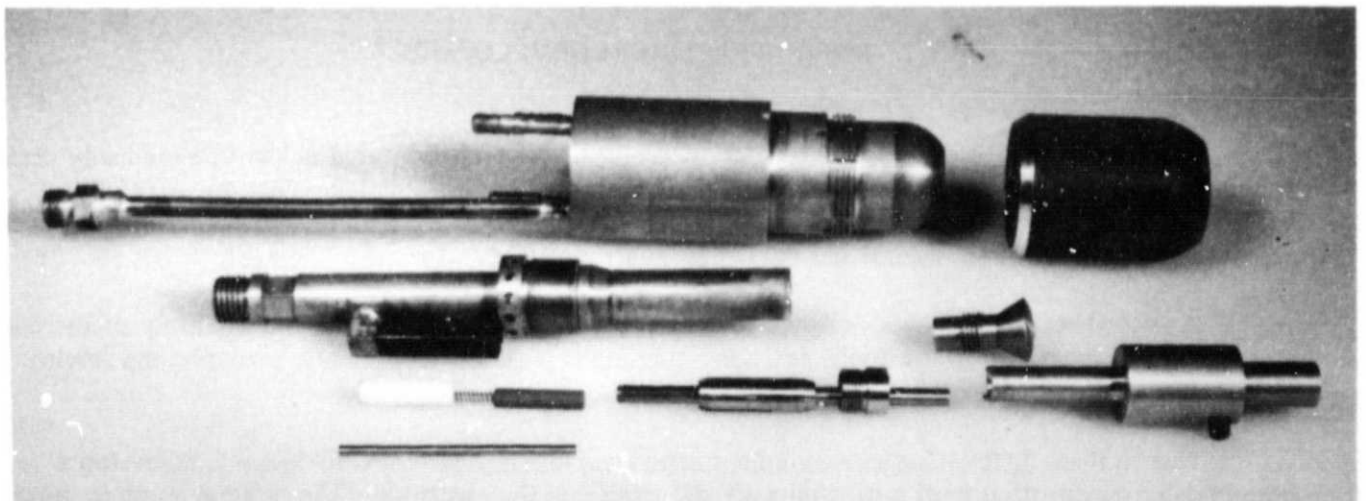

Figure 7. MSFC developed torch (original concept) ORIGINAL PAGE IS OF POOR QUALITY

TECHNOLOGY EXCHANGE

As the VPPA welding process is being developed and refined in the Productivity Enhancement Facility at MSFC, and is being implemented at the Michoud Assembly Facility, it is necessary to provide training and familiarization to MAF personnel.

During the period covered by this report, eight production operations welding engineers from MAF received three to five day indoctrination courses.

Approximately fourteen production operation welders from MAF were given two to three week training and familiarization courses on the VPPA process and associated equipment.

Weld tooling concepts that are being developed on the Large Horizontal VPPA Weld Development Tool were presented to three manufacturing engineers in courses that lasted up to a week.

CONCLUSION

The Variable Polarity Plasma Arc Welding system continues to show the capability to reduce weld repair costs through virtual elimination of porosity, reduction of joint preparation costs through elimination of the need to scrape or draw file faying surfaces, and reduction of depeaking costs by reducing the amount of peaking.

Welding parameter allowables were established for weld thicknesses of 0.650 in., 0.800 in., and 1.00 in. Weld strength certification requirements of 36 KSI for thicknesses of 0.400 in. to 0.750 in. and 35 KSI for thicknesses of 0.750 in. to 1.100 in. were met.

Tooling development commensurate with the VPPA process is underway and will be reported at a later date.

Welder training programs have continued and welds on flight hardware have been made on two more production fixtures (5017 and 5014) at the Michoud Assembly Facility.

A Pathfinder Project, in which a pilot production operation initiates final implementation of the VPPA process into the Space Shuttle External Tank assembly process, was successfully completed and the resultant hardware became flight certified.

As a result of the successful process development program and initial implementation effort, plans are underway to incorporate the VPPA process on several other fixtures at MAF to increase the output potential of the major weld fixtures. In addition, the high quality of VPPA welds merits strong consideration for reducing the 100 percent x-ray inspection now imposed on the welds of the external tank.

APPROVAL

THE VARIABLE POLARITY PLASMA ARC WELDING PROCESS: ITS APPLICATION TO THE
SPACE SHUTTLE EXTERNAL TANK – SECOND INTERIM REPORT

By A. C. Nunes, Jr., E. O. Bayless, Jr., and W. A. Wilson

The information in this report has been reviewed for technical content. Review of any information concerning Department of Defense or nuclear energy activities or programs has been made by the MSFC Security Classification Officer. This report, in its entirety, has been determined to be unclassified.

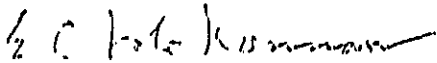

R. J. SCHWINGHAMER
Director, Materials and Processes Laboratory