

THE AERODYNAMIC CHALLENGES OF SRB RECOVERY

D. L. Bacchus and D. A. Kross
 NASA/Marshall Space Flight Center
 Huntsville, Alabama

and

R. D. Moog
 Martin Marietta/Denver Division
 Denver, Colorado

ABSTRACT

Recovery and reuse of the Space Shuttle solid rocket boosters was baselined at the initiation of the program to support the primary goal to develop a low cost space transportation system. The recovery system required for the 170,000-lb boosters was for the largest and heaviest object yet to be retrieved from exoatmospheric conditions. State-of-the-art design procedures were ground-ruled and development testing minimized to produce both a reliable and cost effective system.

The ability to utilize the inherent drag of the boosters during the initial phase of reentry was a key factor in minimizing the parachute loads, size and weight. A wind tunnel test program was devised to enable the accurate prediction of booster aerodynamic characteristics. Concurrently, wind tunnel, rocket sled and air drop tests were performed to develop and verify the performance of the parachute decelerator subsystem. Aerodynamic problems encountered during the overall recovery system development and the respective solutions are emphasized.

INTRODUCTION

At the onset of the Space Shuttle program, numerous trade studies investigated means to develop a cost effective space transportation system. One conclusion drawn from these studies was that recovery, refurbishment and reuse of the Solid Rocket Boosters (SRBs) would provide a significant cost savings over expendable boosters.¹ This conclusion was based in part on the assumption that a recovery system could be developed utilizing a current state-of-the-art design approach. This challenge was accepted by the Marshall Space Flight Center in May 1972 when this center was given overall responsibility for developing the SRB recovery system. The challenge has been successfully met as evidenced by the initial Shuttle flight verification test in April 1981 and in subsequent Shuttle flights.

Aerodynamics have played a key roll in the recovery system development. The purpose of this paper is to address some of the aerodynamic issues and trades and how various aerodynamic challenges were met through a combined conventional and innovative systematic approach aimed at providing both a reliable and cost effective system.

A trace of the historical development of the recovery system and the aerodynamic challenges encountered cannot begin without first a brief description of the SRB configuration and reentry profile. Referring to the reentry sequence in Figure 1, the twin boosters burn out and separate from the remaining Orbiter/External Tank at an altitude of approximately 150,000 ft. After reaching an apogee near 220,000 ft, the 170,000-lb spent SRBs reenter the atmosphere in a random tumbling mode. After an initial deceleration phase during which the Mach number decreases from approximately 5.0 to 0.5, the nose cap is ejected initiating the deployment sequence of the decelerator subsystem parachutes. The 54-ft drogue parachute, deployed at an altitude of approximately 15,000 ft, stabilizes the booster in a tail first attitude. The drogue is also used to deploy a cluster of three 115-ft main parachutes at an altitude near 6500 ft. The main parachute system provides the final deceleration to the nominal 87 ft/sec water impact velocity.

A schematic of the SRB illustrating the location of the recovery system major elements is provided in Figure 2. The parachutes packs, as shown, are contained in the forward portion of the booster. An 11.5-ft pilot, used to deploy the drogue, is located in the nose cap. At the proper altitude, determined by a barometric switch, the nose cap is jettisoned by firing three 30,000-lb thrusters. As shown by the sequence in Figure 3, the nose cap is connected by a three-legged bridle and riser to the pilot pack, and utilizing the drag of the cap deploys the pilot parachute.

Main parachute deployment, again initiated by a baroswitch signal, occurs when the frustum is severed by a linear shaped charge. The frustum then descends under the drogue to water impact and is recovered along with the booster approximately 140 n.mi. downrange of the launch site.

ESTABLISHMENT OF RECOVERY SYSTEM BASELINE

In the initial design definition phase of SRB recovery system development, two primary issues received the major emphasis. These were (1) how to provide high altitude booster deceleration to achieve conditions suitable for parachute deployment, and (2) how to optimize the recovery system for water impact. For both of these issues, the requirements to utilize only state-of-the-art concepts and to minimize cost and complexity of recovery eliminated some of the potential options such as the use of active stabilization or attitude control systems.

Some of the options considered for the high altitude deceleration phase of reentry are shown in Figure 4. These include the use of various drag producers such as extendable flaps, drag petals and inflatable type devices such as ballutes. However, a drawback to each of these methods is that they all tend to orient the booster centerline in the streamwise direction resulting in a tremendous decrease in SRB drag. From this standpoint, a high angle of attack or "broadside" reentry mode appeared highly desirable. In fact, the natural aerodynamic drag of the booster alone could potentially provide the deceleration required to generate the conditions needed at parachute deployment. Although the best method of achieving a near broadside reentry mode had not been determined, this reentry concept was adopted because of the numerous advantages it offered.

Concurrently, other studies were being performed to optimize the final deceleration system. One key trade considered an all parachute versus a hybrid parachute braking rocket system. The results (Fig. 5) indicated that for water impact velocities above 65 ft/sec a pure parachute system would be lighter. Studies of water impact had concluded that a 80 to 100 ft/sec tail first impact would provide a good compromise between initial impact and slap down loads. The pure parachute system was therefore baselined to provide both a lighter weight and less complex system.

With a booster recovery scheme developed, several key aerodynamic challenges remained including (1) determining the best means of achieving a broadside reentry, (2) developing an SRB aerodynamic data base, (3) establishing design requirement for the parachute system, (4) optimizing the parachute system from a design/performance standpoint, and (5) verifying overall performance through a systematic and cost effective development test program.

Since the parachute design requirements were directly dependent on the SRB initial deceleration phase, it was paramount that the initial SRB deceleration phase be investigated first. If the booster center of gravity were ideally located at approximately 53 percent body length from the SRB nose (near centroid of area) the booster would tend to trim at an angle of attack near the optimum 90-deg. The booster center of gravity at burnout, however, is 5 or 6 percent further aft which causes the booster to tend to trim in a somewhat tail first and lower drag attitude.

Early studies considered an aerodynamic "fix" to force the booster to reenter closer to 90 deg. To accomplish this several possibilities were explored. In one concept strakes were added to the fore and aft section of the SRB on opposite sides of the vehicle. The strakes would create a yawing moment sufficient to induce a flat spin. This concept, however, required a tight control of the static margin and also roll stabilization to assure that the strakes would be oriented for maximum effectiveness.

A more practical solution proposed² also utilized strakes but in a somewhat different manner. By adding strakes at several circumferential locations on the SRB aft skirt, an effective rearward shift in center of pressure of approximately one percent body length could be achieved.

Since the addition of strakes added weight and cost to the SRB, recovery studies continued to investigate reentry with an unmodified booster. The major concern with this approach dealt with the predictability of conditions at parachute deployment. Because of an integral effect of the phasing of the lift vector during reentry, significantly different trajectories could result from small differences in booster mass characteristics, aerodynamics, and other system uncertainties. It was difficult not only to establish a nominal reentry trajectory but also to define reasonable worst case conditions to establish design requirements for nose cap separation and drogue deployment.

The solution was to utilize a "Monte Carlo" approach to establish a set of approximately 400 possible trajectories. In each trajectory the system dispersions were selected using a random distribution for each established uncertainty. The booster aerodynamics, except for the center of pressure, were also treated in this manner. The center of pressure dispersion was fixed at the 95-percentile worse case direction (forward) to establish a set of design conditions for parachute deployment.

One result of the reentry analysis was the establishment of a booster center of gravity aft limit for recovery system design purposes. As the center of gravity moves aft, the conditions at drogue deployment become increasingly sensitive to system uncertainties and the chances of a "lock-up" to a catastrophic tail first trim more probable. The final selection of a 59-percent aft limit was a reasonable compromise between SRB weight distribution and acceptable conditions for drogue deployment.

Using the Monte Carlo trajectory set, parachute design requirements could also be traded against probability of a successful recovery to optimize the recovery system from a cost standpoint. This resulted in a design based on a 99th percentile trajectory eliminating the few cases resulting in near tail first reentries.

The primary tasks remaining were to (1) develop a valid aerodynamic data base for the final SRB baseline configuration, and (2) develop an optimum parachute system to meet the established requirements. The manner in which these tasks were undertaken will now be addressed.

SRB AERODYNAMIC DATA BASE DEVELOPMENT

The SRB reentry aerodynamic characteristics were developed primarily by a series of wind tunnel tests utilizing various size models, several test facilities and, in some instances, specialized test techniques. The data base development task was made more complex by the large test matrix required to encompass the wide range of potential reentry conditions inherent to a randomly tumbling reentry body. Other problems experienced were attributed to Reynolds number and sting interference effects.

REYNOLDS NUMBER EFFECTS

Although a major portion of the SRB reentry is supersonic, the greatest challenge in developing the data base was to obtain accurate aerodynamic characteristics in the subsonic flow regime. The reentering SRB is essentially a cylinder in crossflow type problem that is compounded by the existence of very large Reynolds numbers ($\approx 2 \times 10^7$) and SRB protuberance effects. Because of the importance of Reynolds number, every attempt to match, maximize or determine the effects of this parameter on SRB reentry aerodynamics was incorporated into each test.

Figure 6 provides a comparison between flight Reynolds number and levels obtained in wind tunnel testing. As shown, a reasonably close match was achieved with tests in the MSFC High Reynolds Number Wind Tunnel (HRWT). Reynolds numbers up to 2.0×10^6 were also obtained in large (2.8 percent) model tests in the Ames Unitary Tunnel. As expected large variations with Reynolds number were obtained.

STING INTERFERENCE EFFECTS

Although sting interference effects are present in practically all wind tunnel test results, the magnitude of the error introduced can normally be ignored. For the SRB tests, however, sizable sting effects were sometimes obvious as illustrated in Figure 7. The pitching moment coefficients presented as a function of angle of attack were obtained for identical configurations and conditions using two different model support systems; one a side mounted strut and the other a sting attached to the nose of the SRB model. The discontinuity is indicative of the presence of sting effects but not necessarily the magnitude since both sets are erroneous to some degree.

Sting interference problems have typically been associated with the testing of bodies at high angles of attack. However, in the SRB tests the problem has been amplified by the necessity to test at high Reynolds numbers where the resulting high loads dictate the use of massive model support hardware. However, even the low Reynolds number tests utilizing smaller struts demonstrated significant sting effects and made comparing data obtained from different facilities at similar conditions extremely difficult. The severity of the problem is also illustrated by Figure 7 which shows that the sting effect can have a sizeable influence on the apparent static trim angle. The 20-deg difference measured by the two systems would not be acceptable if treated as an uncertainty in developing conditions at nose cap deployment.

Because of the criticality of defining the proper reentry conditions, a special test program³ was initiated to quantitatively determine the effects of sting interference. The goal of this program was to (1) obtain sting interference corrections for model support systems used in MSFC TWT, MSFC HRWT and Ames Research Center test results, and (2) determine the optimum sting arrangement to minimize sting effects in future tests.

The technique employed was similar to that utilized in Reference 4. That is, a dummy sting was used in conjunction with a live balance and sting to back out the sting effect (Fig. 8). Hardware was also developed to determine corrections for both the nose and side mount configurations. This provided an indication of the resulting data uncertainty, due partially to a mutual interference effect between dummy and live sting, and also the data needed to establish the best sting setup for given conditions.

A photograph of the sting interference test setup for the HRWT facility (Fig. 9) illustrates the size of the sting system relative to the SRB model. An example comparison of the sting corrected nose and side mount data with design data and large model test results (SALIF) is shown in Figure 10. In this particular case, the corrected data are to the right of both data sets. The resulting higher trim angle creates a more severe reentry environment, further illustrating the importance of these tests.

PARACHUTE PERFORMANCE DATA BASE DEVELOPMENT

The parachute system for the SRBs evolved from a systematic development/verification test program that included wind tunnel, rocket sled and air drop testing. In order to minimize development costs it was mandatory that the number of air drop tests be reduced from the thirteen originally planned to only six. This success oriented approach placed a greater burden on predrop configuration design optimization including that of the parachute deployment method and parachute configuration to achieve the desired performance.

WIND TUNNEL TEST PROGRAM

Wind tunnel tests^{5,6,7} were performed for two primary purposes. One was to parametrically investigate the performance of 20-deg conical ribbon parachutes to augment the data base available. The configurations tested were appropriate for the drogue, drogue pilot and main parachute system. The second major objective was to investigate several potential deployment methods for the drogue parachute (Fig. 11). One-eighth scale models of the drogue parachute of 16- and 24-percent porosity were used for the drogue performance and drogue deployment phases of the test. Since the same parachute models were also used for the main parachute performance tests the ribbon width and spacing was geometrically scaled for the drogue parachutes only.

A photograph of the model used in the drogue deployment tests is shown in Figure 12. In these tests both the parachutes packs and the nose cap were geometrically and mass scaled to simulate the deployment dynamics. A photograph showing typical parachute models is shown in Figure 13.

These tests accomplished all of the goals established. A recommended method of deploying the drogue parachute was later adopted and proved successful. Performance characteristics were established for the SRB candidate 20-deg conical ribbon parachutes including the effects of geometric porosity, reefing, clustering, suspension line length and forebody interference. These data enabled a sound configuration selection in the early design stage that would basically remain unchanged throughout the remaining development program.

ROCKET SLED TEST

The initial phase of parachute deployment, i.e., nose cap separation and pilot parachute deployment, was considered a critical aspect of the recovery scheme. To verify that the full scale flight configuration would perform as predicted and demonstrated in scaled model tests, a rocket sled test was performed^{8,9} at the Rocket Sled Test Facility at Sandia Laboratories, Albuquerque, New Mexico. This test provided a functional checkout of nose cap separation, structural verification of the nose cap/pilot chute rigging under design limit load environment and aerodynamically the dynamic behavior of nose cap separation and pilot deployment for both a worst case windward ($\alpha = 80^\circ$) and a high alpha/high dynamic pressure (140 deg/270 psf) test condition.

The sled test was both a technically sound and cost effective alternative to an air drop for development testing this portion of the recovery system. Primarily, it provided a means of controlling the most critical test parameters such as velocity and SRB angle of attack. Figure 14 illustrates the general configuration and the test setup for the 80-deg angle-of-attack test. The configuration was comprised of a flight-type nose cap, jettisoned by firing three thrusters, and an adapter representing a small portion of the nose cap frustum.

For the 80-deg test, 16 HVAR (6500-lb thrust) rockets were used to accelerate the test fixture down the 5000-ft-long track to a peak velocity of 465 ft/sec. Following a brief coast period, the nose cap was ejected at a dynamic pressure of 197 psf. The test sequence is shown in Figure 15. No deployment problems were experienced and the cap cleared the drogue and pilot chute packs by a substantial margin.

Similar success was achieved with the 140-deg test which utilized 21 HVAR rockets. For each of the tests, film analysis and laser tracking data were used to determine nose cap ejection velocities and the cap displacement relative to the parachute packs.

AIR DROP TESTS

An important element of the SRB decelerator subsystem development program was the air drop program^{10,11} performed at the National Parachute Test Range, El Centro, California. These tests were used to provide functional, structural and performance evaluation of the overall parachute system. The program consisted of six drops employing a 48,000-lb drop test vehicle (DTV) which was released from the B-52 mothership.

A schematic of the DTV configuration is shown in Figure 16. The major components include a ballast section, a flare section, an aft facing frustum and a nose cap. Three fins, not shown in this figure,

were added beginning with the third drop test to improve the DTV stability. Similar to the flight booster, the drogue and pilot chute packs are contained in the nose cap and the main parachute pack in the frustum. However, unlike the flight sequence which is initiated by ejecting the nose cap, the DTV contains a small mortar deployed vane chute which deploys a 11.5-ft nose cap extraction chute.

A comparison of the relative size of the DTV and SRB is shown in Figure 17. The significant weight difference (48,000 versus 170,000 lb) rendered it impossible to develop significant loads in more than one reefing stage of the drogue or main during a single test. Furthermore, in some cases, test peculiar reefing ratios and sequencing were required to set up the desired deployment condition. For the main chute cluster tests, the DTV deceleration was so great during deployment that it was not possible to obtain a high load condition. Single main chute tests were therefore used to evaluate the parachute structural integrity and cluster tests at flight deployment conditions used to assess the functional and performance aspects.

A matrix of the drop test program and the primary test objectives is contained in Table I. Note that in some tests planned objectives were not fully met. The reasons involve not meeting test conditions (Test 1), not attaining the desired loads (Test 2), or in having a significant failure (Test 3). The objectives were met, however, within the total drop test program.

A typical drop test sequence is illustrated in Figure 18. The test conditions for the drogue initial inflation were achieved by allowing the DTV to free-fall for a predetermined time from the drop altitude ranging from approximately 16,000 to 22,000 ft.

The measurement program consists of drogue and main chute load sensors, accelerometers, rate gyros, extensometers and a total pressure probe. Photographic coverage included two DTV onboard cameras, chase plane cameras, and ground based cameras. Space position data were obtained from the range cinetheodolite system.

A typical performance comparison between wind tunnel and drop test results¹² is contained in Figure 19. In general, the drop tests verified the predrop test performance predictions for the full open parachutes. The drop tests also permitted a refinement of the reefing line lengths to balance or optimize the loads experienced on each of the three stages for both drogue and main parachute systems.

Aside from the measured data obtained, visual coverage of the drop test program provided a significant insight into the aerodynamic behavior of the pilot, drogue and main parachute system during both the deployment process and during steady state conditions. Figure 20 illustrates some of the drogue deployment characteristics that were revealed during Test 2. As the drogue canopy emerged from the bag, the sailing lines rotated the canopy approximately 180 deg relative to the DTV. This also caused a twisting or wrap-up of the drogue suspension lines as shown. Although undesirable, no damage or appreciable drag loss resulted from this behavior. This anomaly was traced to the use of a test peculiar reefed pilot parachute which did not provide sufficient drogue pack acceleration to overcome aerodynamic forces on the lines.

Main parachute deployment has always been a major concern because the parachutes must be deployed out of a hard container (frustum) containing jagged edges at the separation plane. In Test 5 the frustum moved laterally after separating causing a skewed deployment of the three main parachutes. The cause of this is thought to be related to the dynamic motion of the DTV prior to frustum separation. Another problem experienced in single main tests is that of inflation overtake. To meet the Test 2 objective of deploying a main chute in a design limit environment, the drogue chute was reefed to 27 percent full open. Because of the resulting slow deployment velocity a phenomenon called "inflation overtake" occurred (Fig. 21). When this happens the parachute begins to inflate prior to being fully extracted from the deployment bag resulting in contact between the parachute and container. In Test 2, the result was several torn horizontal ribbons in one gore and in the vicinity of the canopy skirt.

Although many of the problems experienced were related to test peculiar conditions or configurations, a good understanding was gained relative to aerodynamic sensitivities to changes from the baseline design. This understanding has already enabled some modifications to the decelerator subsystem to accommodate unforeseeable changes in the SRB design. However, of primary importance, the drop test program established the needed confidence that the subsystem was ready for qualification testing on the actual Space Shuttle flights.

CURRENT/FUTURE CHALLENGES FOR SRB RECOVERY

Although a recovery system has been successfully developed for the Space Shuttle SRB, both planned and proposed changes in the booster design are presenting new challenges. For instance, the reentry center of gravity has already migrated 16 in. beyond the original aft limit established for recovery system design. This movement is primarily a result of deleting development flight instrumentation,

adding approximately 1000 lb of structural reinforcement in the aft skirt region to take higher than expected water impact loads, and reducing the motor segment weight. To compensate for the hotter trajectory resulting from the more tail first reentry, some reconfiguring of the parachute sequencing and/or reefing will most likely be required.

An alternative to structurally strengthening the booster aft skirts is to reduce the water impact velocity. This approach, currently planned for the twelfth Shuttle flight, will require the development of a larger main parachute.

Another major challenge will be the development of a new drogue and pilot parachute system for the planned filament wound case SRB. This booster, although some 30,000 lb lighter at burnout than the current steel case SRB, will nonetheless have more stringent design requirements.

LARGER MAIN PARACHUTE

The larger main parachute system will consist of a cluster of three 136-ft-diameter parachutes of similar design and construction to the 115-ft chutes. This size parachute will provide a reduction in nominal water impact velocity from 87 to 75 ft/sec and can be contained within the volume available in the frustum.

Figures 22 and 23 provide a status of parachute system development relative to size versus peak load and dynamic pressure at deployment respectively. Included for comparison are the Shuttle drogue and main parachutes. These charts illustrate that the larger main parachute system will be stretching the boundary of parachute technology with respect to a combination of size, load, and deployment conditions. State-of-the-art design techniques can still be utilized, however, and the development risk is considered to be low.

A three-drop development test program is planned utilizing the DTV shortened by 54 in. to reduce B-52 hook loads. These tests will be performed at the Naval Weapons Centers, China Lake, California.

FILAMENT WOUND CASE PARACHUTES

The filament wound case SRB is being developed to reduce weight for high performance Shuttle missions. This booster, although externally similar to the steel case, is some 30,000 lb lighter at burnout and has a center of gravity almost 3 ft further aft. Because of the more aft center of gravity, the booster trim angle is increased about 10 deg (more tail first) causing a substantial drag loss and decrease in booster deceleration. This results in near sonic conditions at drogue deployment with dynamic pressure above 900 psf. One method available to improve the deployment conditions and currently baselined is to jettison the high performance motor nozzle extension at apogee. This provides a blunter configuration and increases reentry drag which lowers the deployment Mach number to approximately 0.95 and dynamic pressure to 715 psf.

The greatest challenge for the development of this system will be to devise a development test program that is both meaningful and cost effective which will verify that the deployment system will function properly in a high Mach, high dynamic pressure environment. A combination of rocket sled and air drop tests is currently planned to accomplish this end.

SUMMARY

The challenge of developing the recovery system for the Space Shuttle SRB has been successfully met as demonstrated by both development air drop tests and flight experience. The inherent aerodynamic characteristics of the reentering SRBs have been utilized to significantly diminish the requirements on the parachute system. The parachute system itself has been systematically optimized through wind tunnel, rocket sled and air drop tests to minimize development costs and maximize overall reliability. A similar approach using the current system data base as a foundation can now be used to develop recovery systems to meet future, more stringent Space Shuttle recovery system requirements.

REFERENCES

1. Godfrey, Roy E.: Space Shuttle Booster Recovery Planning. In Proceedings of AIAA 4th Aerodynamic Deceleration Systems Conference, AIAA Paper No. 73-441, 1975.
2. Struck, Heinz G.: Strakes, A Simple Means to Improve SRB Pitch Reentry Attitudes. NASA MSFC Internal Memorandum ED31-80-16, June 17, 1980.
3. Conine, B.; and Boyle, W.: Space Shuttle Solid Rocket Booster Sting Interference Wind Tunnel Test Data Analysis. Northrop Services TR-230-2042, 1981.

4. Dietz, W. E. Jr.; and Altstatt, M. C.: Experimental Investigation of Support Interference on an Ogive Cylinder at High Incidence. In proceeding of AIAA 16th Aerospace Sciences Meeting, AIAA Paper No. 78-165, January, 1978.
5. Bacchus, David L.; Vickers, Jack R.; and Foughner, Jerome T. Jr.: Wind Tunnel Investigation of Space Shuttle Solid Rocket Booster Drogue Parachutes and Deployment Concepts. In proceedings of AIAA 5th Aerodynamic Deceleration Systems Conference, AIAA Paper No. 75-1366, November, 1975.
6. Vickers, Jack R.; and Mickey, Fred E.: Wind Tunnel Test Report, SRB Drogue Parachute System. Northrop Corporation, Ventura Division Report NVR 74-45, 1974.
7. Vickers, Jack R.; Mullins, William M.; and Mickey, Fred E.: Wind Tunnel Test Report, SRB Drogue and Main Parachute System, Phase II. Northrop Corporation, Ventura Division Report NVR 76-24, 1976.
8. Kross, D. A.; and Webb, R. W.: Space Shuttle Solid Rocket Booster Decelerator Subsystem Rocket Sled Test Program. In Proceedings of AIAA 6th Aerodynamic Decelerator and Balloon Technology Conference, AIAA Paper No. 79-0437, March, 1979.
9. Webb, R. W.: Rocket Sled Nose Cap Ejection Test Report. Martin Mariette Report SRB-DSS-TM03-10, 1978.
10. Moog, R. D.; Sheppard, J. D.; and Kross, D. A.: Space Shuttle Solid Rocket Booster Decelerator Subsystem Drop Test Results. In Proceeding of AIAA 6th Aerodynamic Decelerator and Balloon Technology Conference, AIAA Paper No. 79-0463, March, 1979.
11. Moog, R. D.; and Sheppard, J. D.: Final Drop Test Report for Solid Rocket Booster Decelerator Subsystem. Martin Marietta Report SRB-DSS-TM11-2, 1978.
12. Moog, R. D.; Bacchus, David L.; and Utreja, Lajpat R.: Performance Evaluation of Space Shuttle SRB Parachutes from Air Drop and Scaled Model Wind Tunnel Tests. In Proceedings of AIAA 6th Aerodynamic Decelerator and Balloon Technology Conference, AIAA Paper No. 79-0464, March, 1979.

TABLE I. PRIMARY DROP TEST OBJECTIVES MATRIX

	Deployment Process		Limit Load Environment		High Q Deployment			Structural Integrity		Performance		
	Broadside	System Functional	Drogue	Single Main	Drogue	Main Cluster	Single Main	Drogue	Single Main	Drogue	Main Cluster	Single Main
Drop 1	•	●	○							●	●	
Drop 2				●				○				●
Drop 3					●							
Drop 4						●						
Drop 5								●				
Drop 6			●				●		●			
Sled Test	●											

*Skewed deployment ($\sigma = 50^\circ$) although not objective.

○ = Objective

● = Accomplished

◐ = Partial accomplishment

ORIGINAL PAGE IS
OF POOR QUALITY

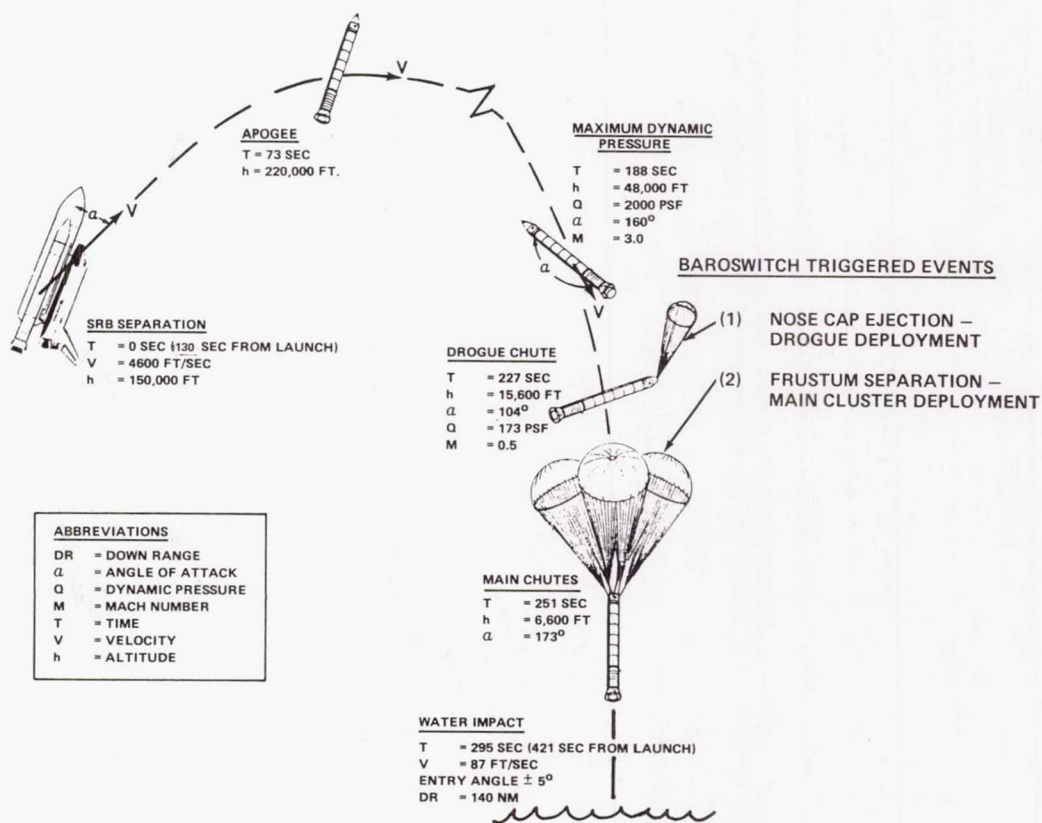

Figure 1. SRB Recovery Sequence of Events.

ORIGINAL PAGE IS
OF POOR QUALITY

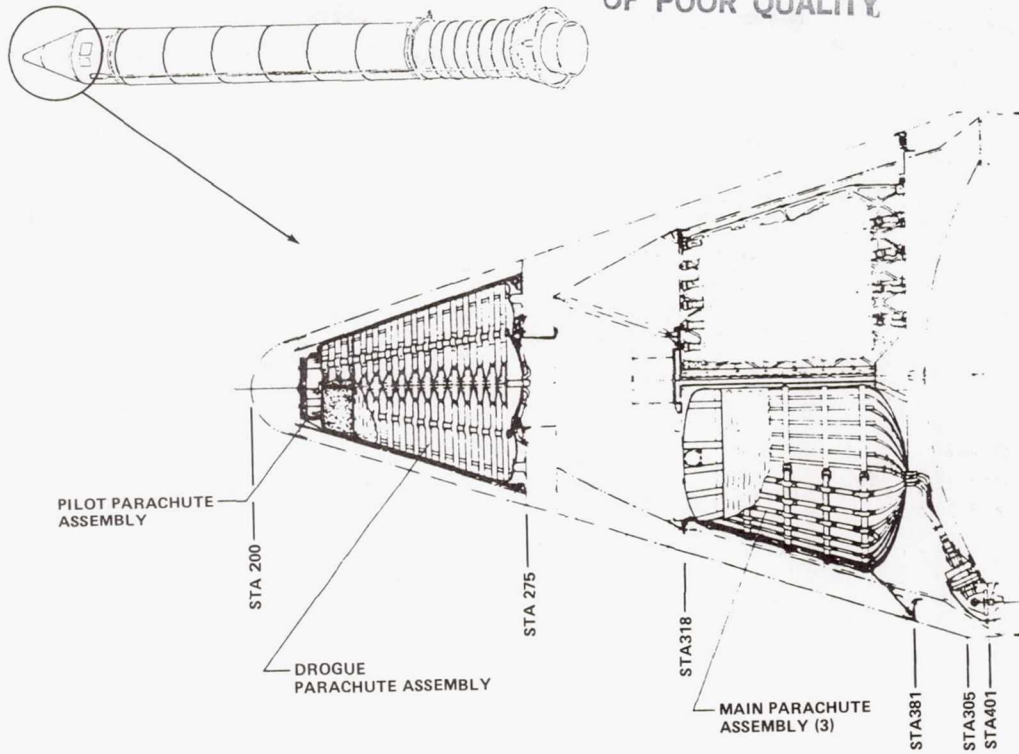

Figure 2. Parachute Locations in SRB.

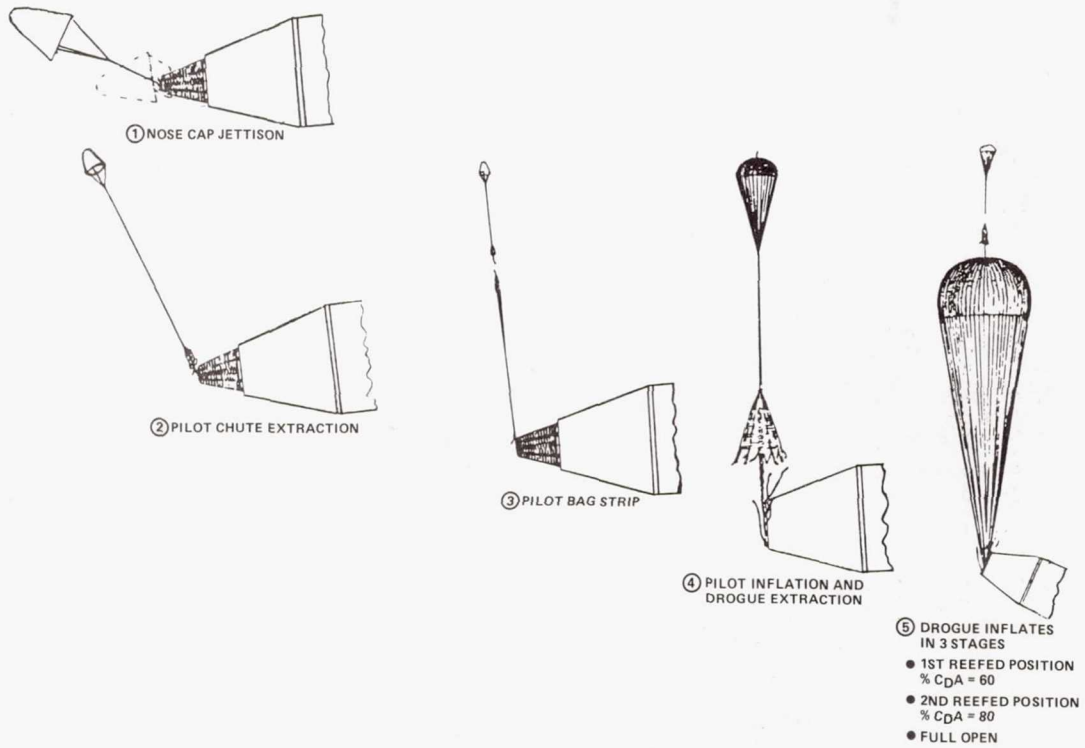
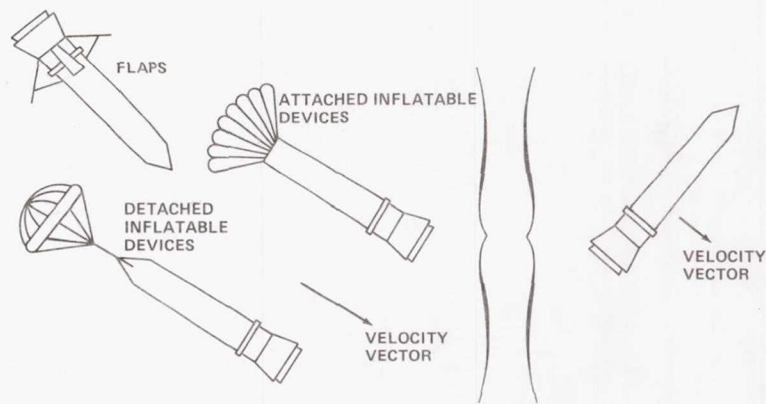

Figure 3. Drogue Deployment Sequence.



ADDED DRAG AREA VS. INHERENT BODY DRAG (HIGH a)

Figure 4. SRB High Altitude Deceleration Concepts.

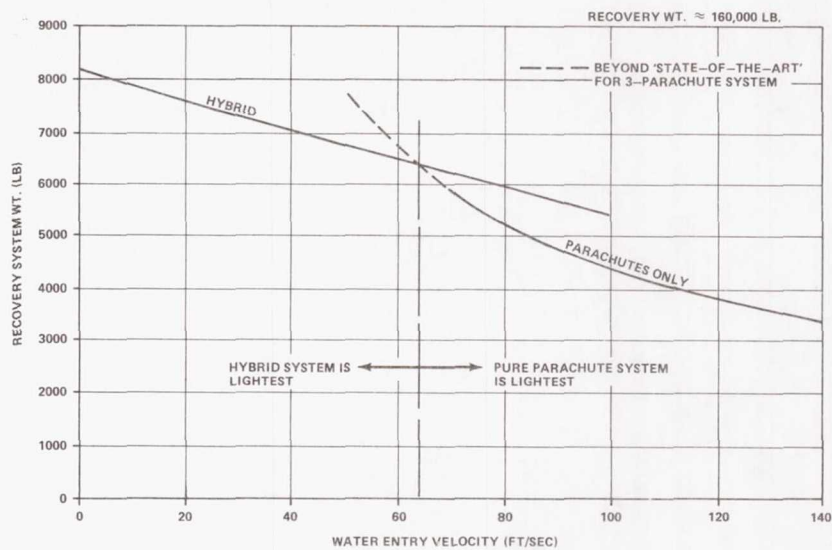

Figure 5. Deceleration System Weight.

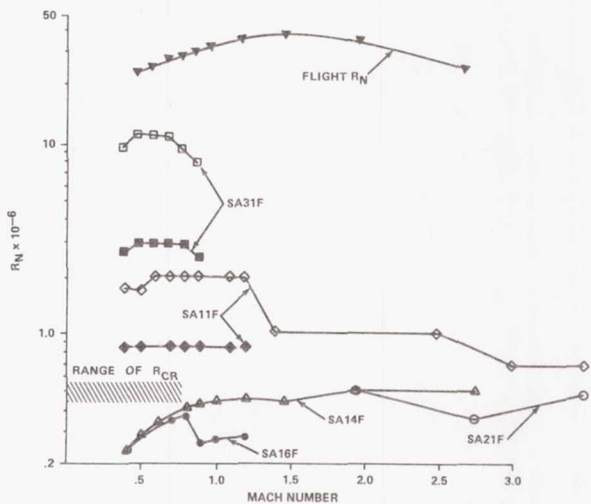

Figure 6. Wind Tunnel Versus Flight Reynolds Number.

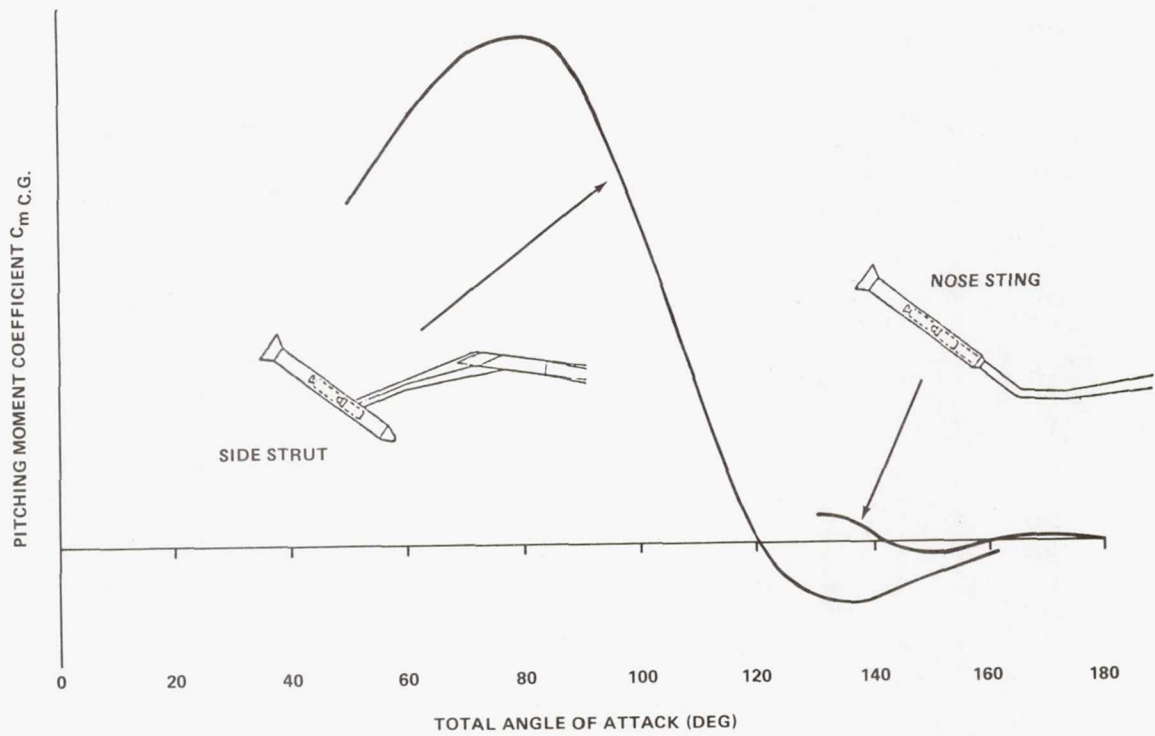

Figure 7. Effect of Model Support Method on Pitching Moment Coefficient.

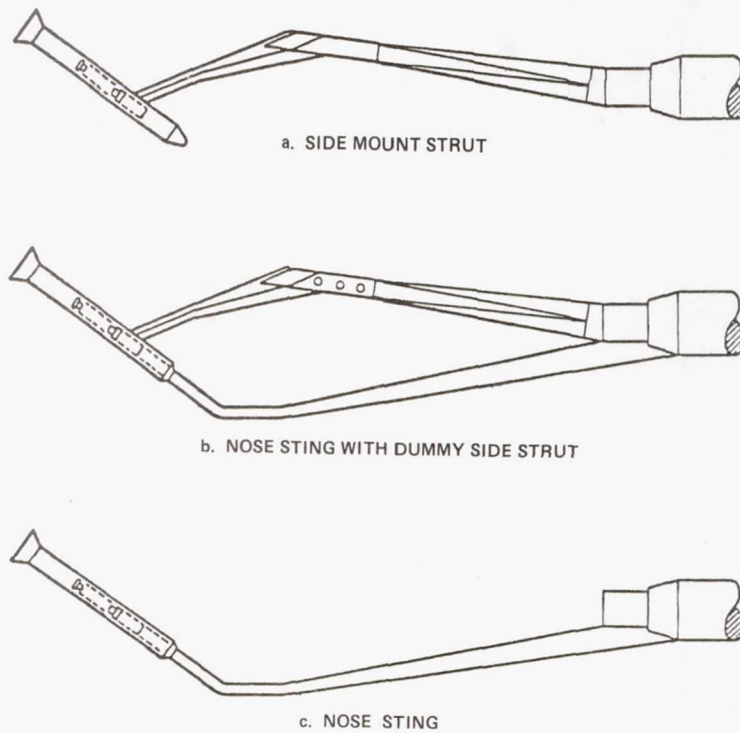

Figure 8. Typical Sting Arrangements for Determining Sting Effects.

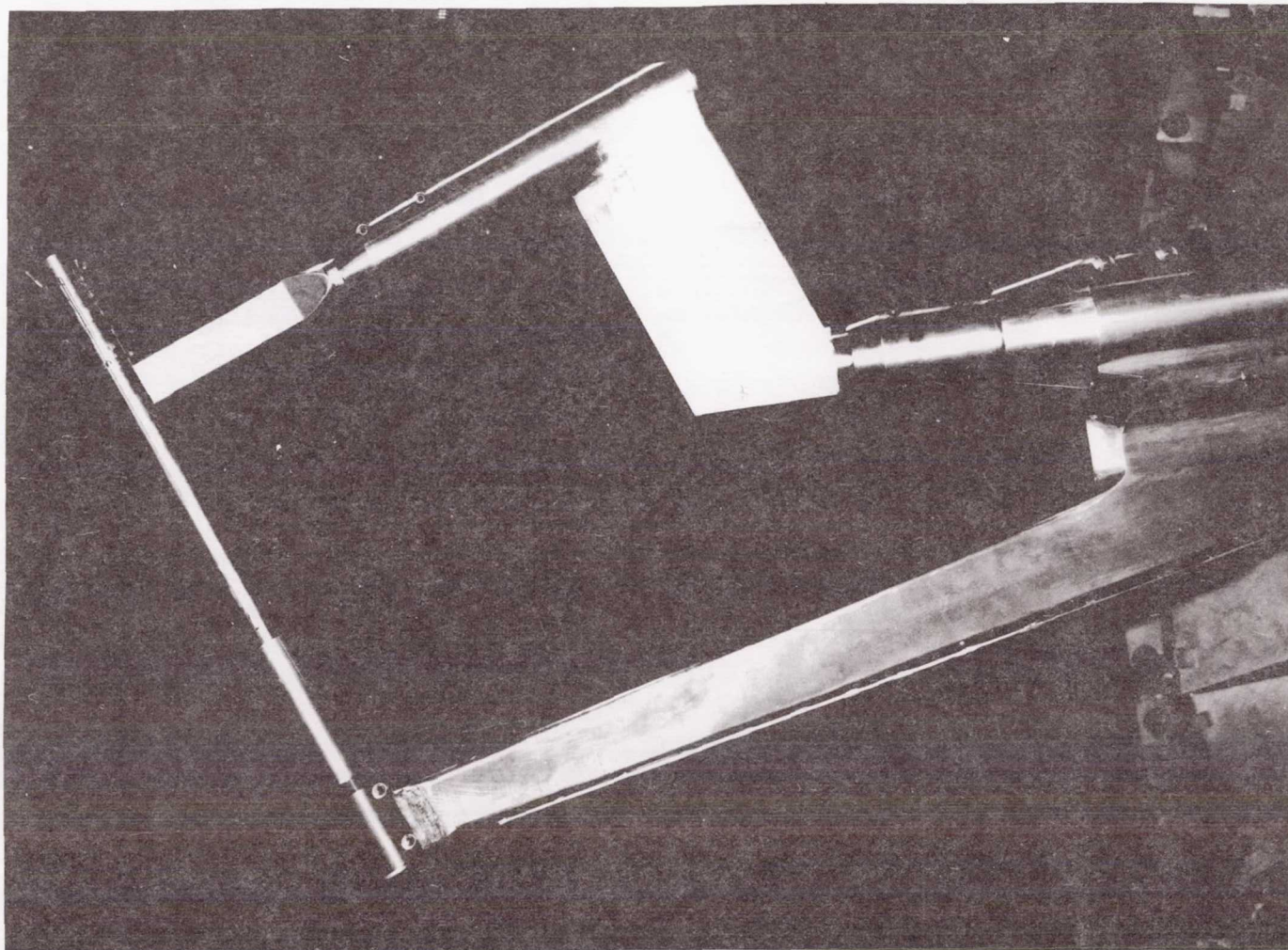

Figure 9. MSFC HRWT Side Strut With Dummy Nose Sting.

ORIGINAL PAGE IS
OF POOR QUALITY

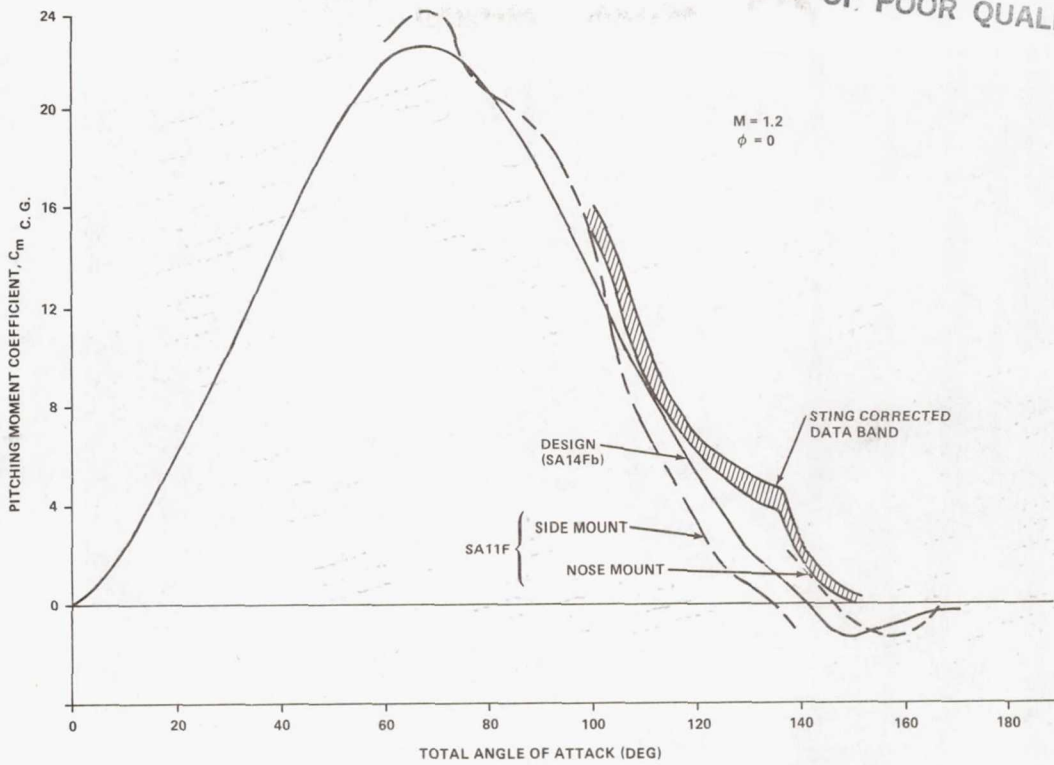

Figure 10. Sting Corrected Pitching Moment Coefficients.

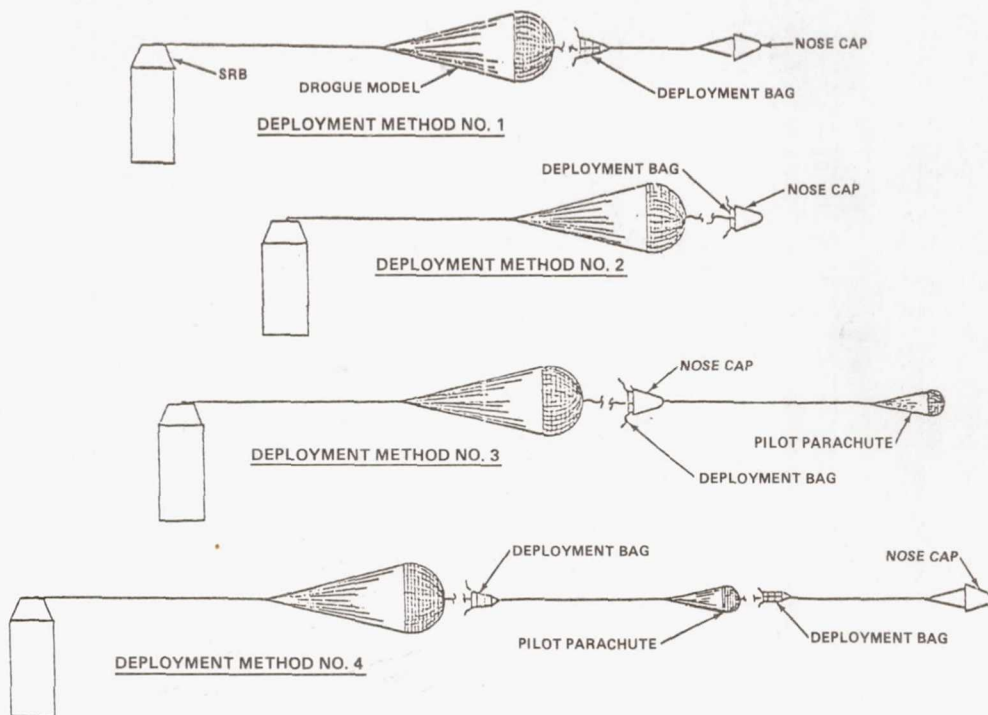

Figure 11. Candidate Drogue Deployment Methods Wind Tunnel Tested.

ORIGINAL PAGE IS
OF POOR QUALITY

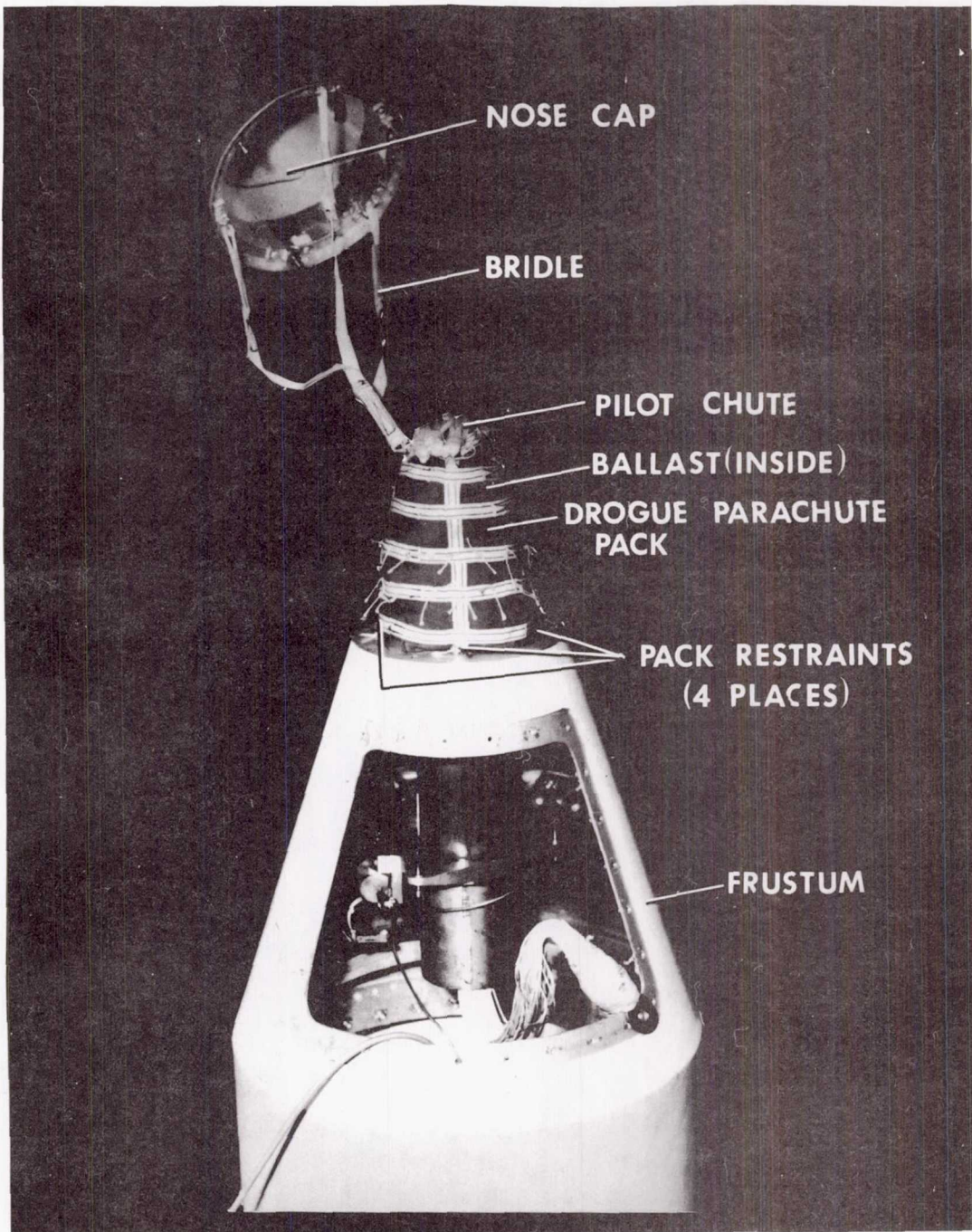

Figure 12. Drogue Deployment Test Hardware.

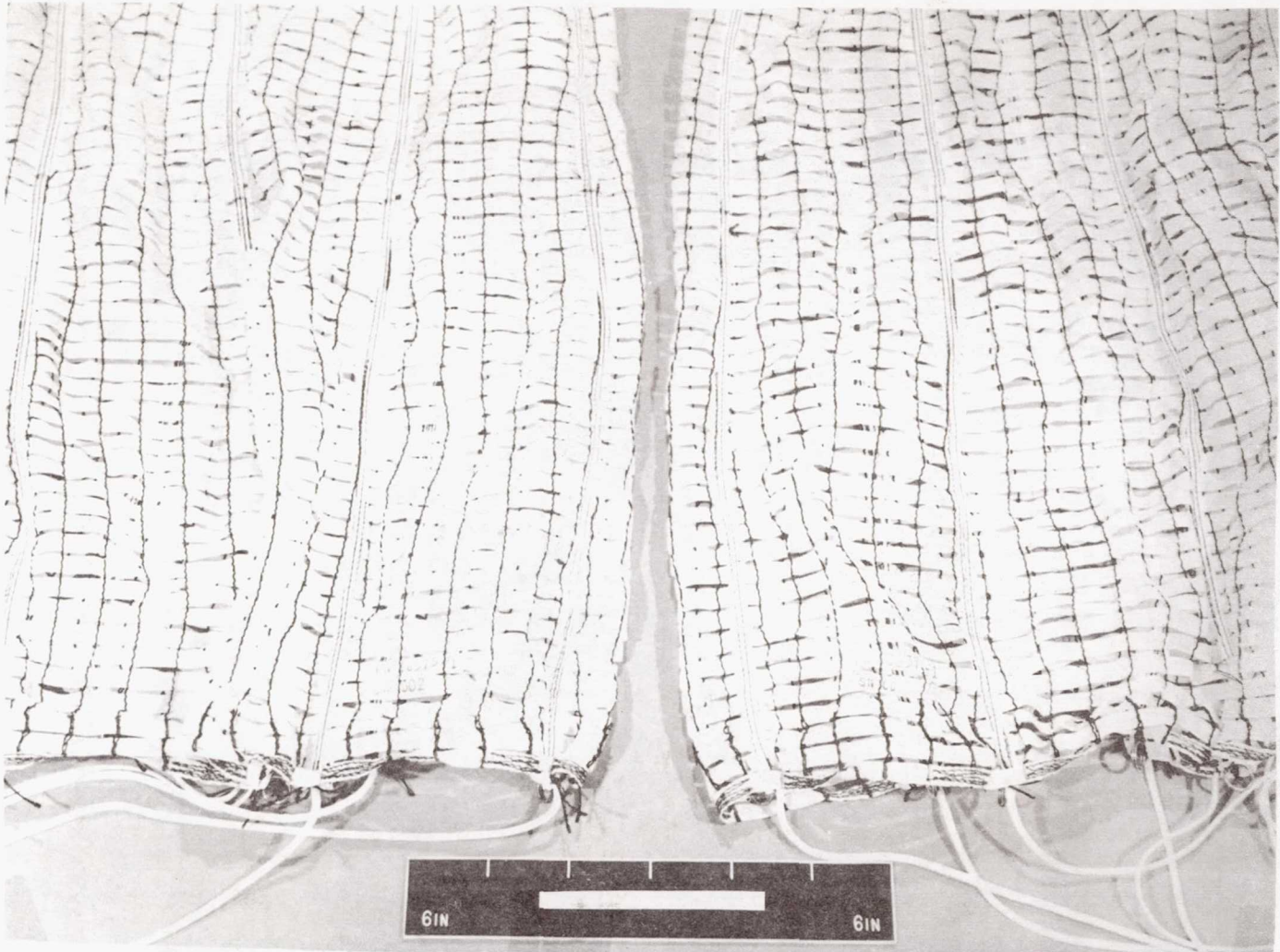

Figure 13. Wind Tunnel Test Ribbon Parachute Models.

ORIGINAL PAGE IS
OF POOR QUALITY

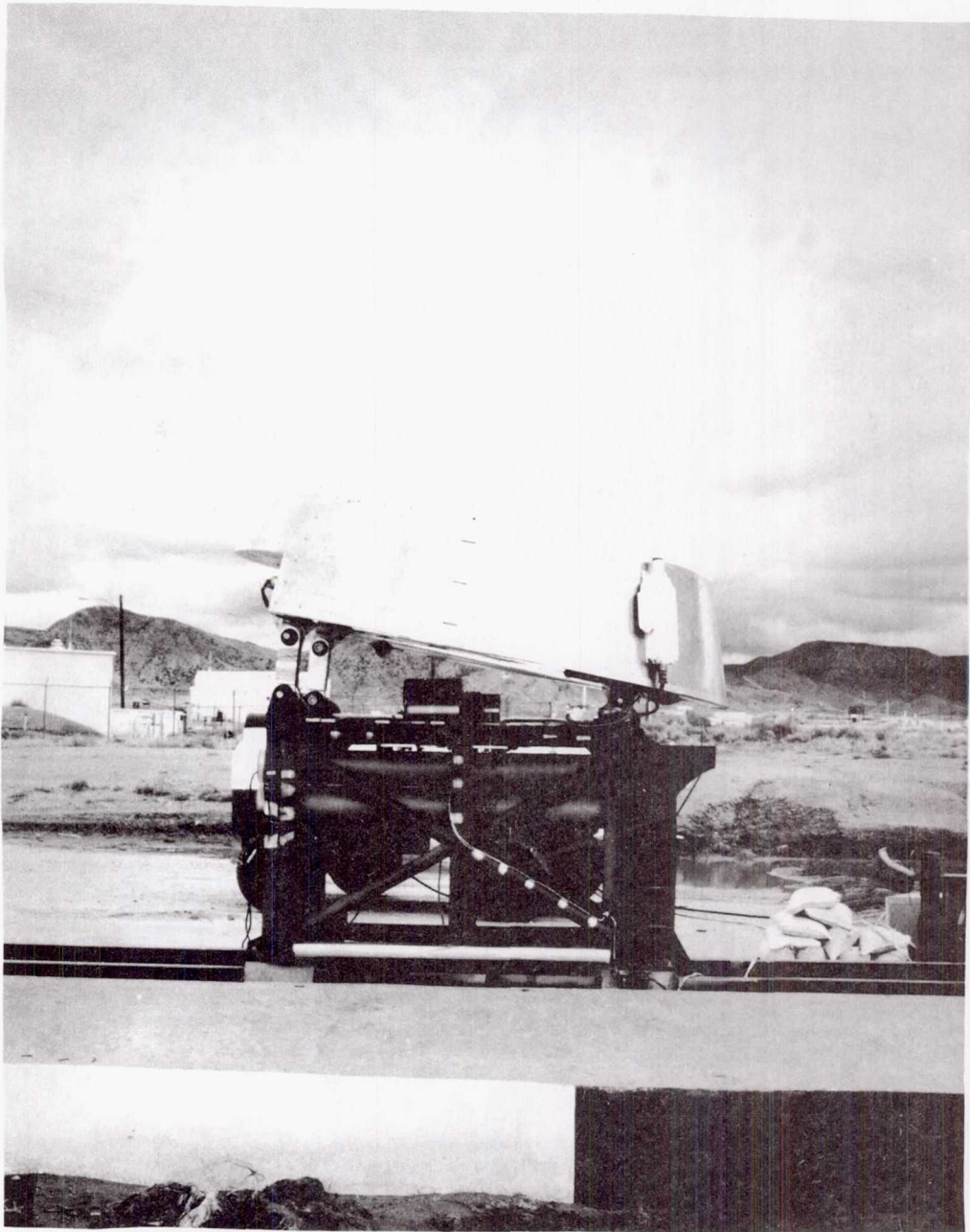

Figure 14. Sled Test Configuration (80-Degree Test).

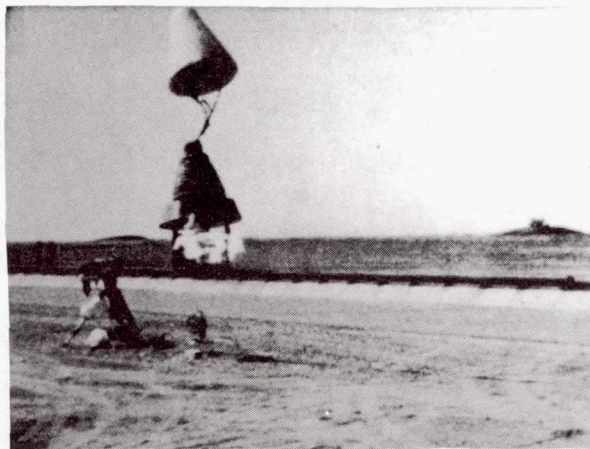
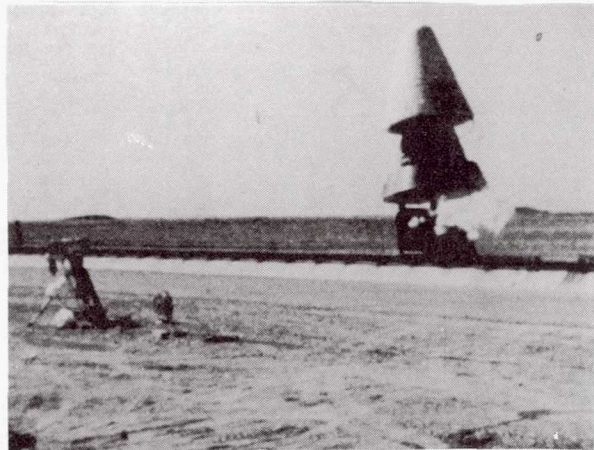
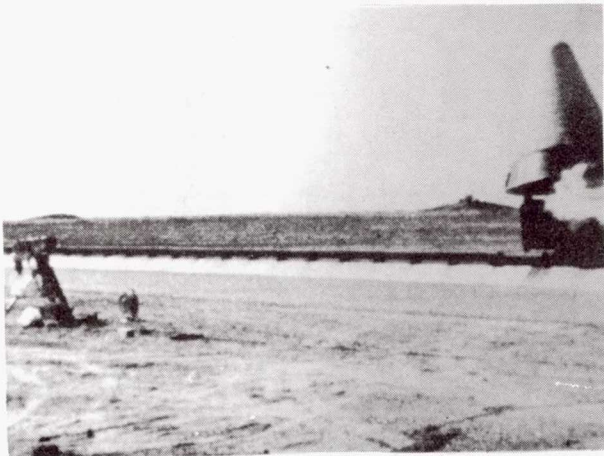

Figure 15. Nose Cap Ejection Sequence (80-Degree Sled Test).

ORIGINAL PAGE IS
OF POOR QUALITY

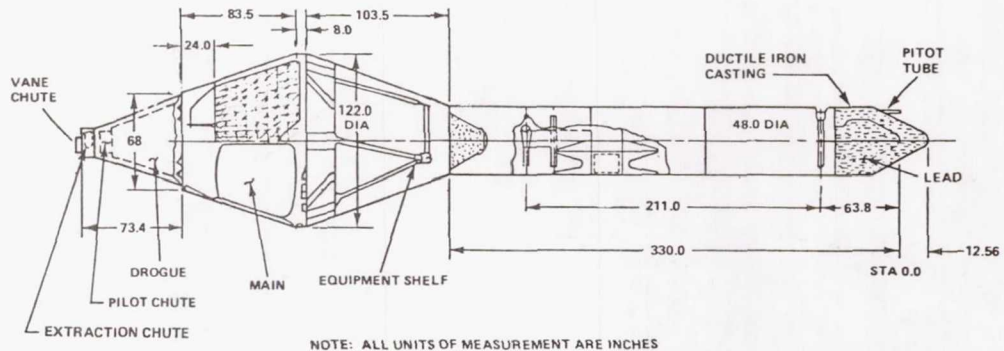

Figure 16. DTV General Arrangement.

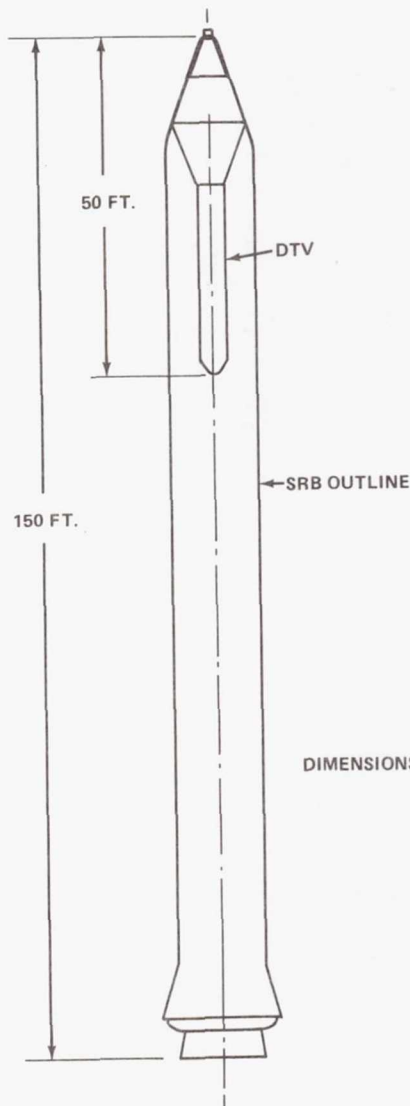

Figure 17. Comparison of DTV and SRB Size.

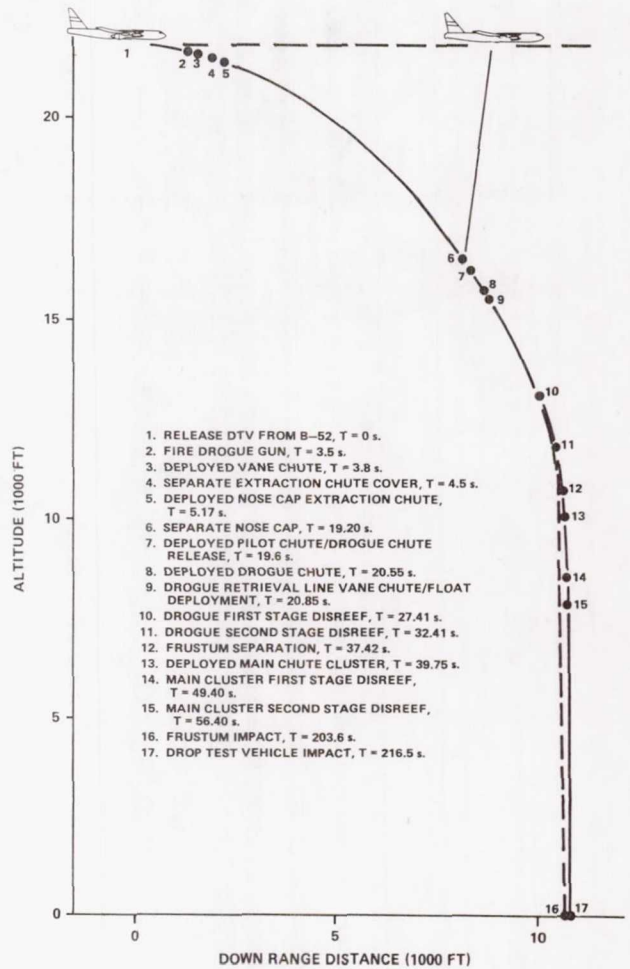

Figure 18. Typical Drop Test Sequence (Test 5).

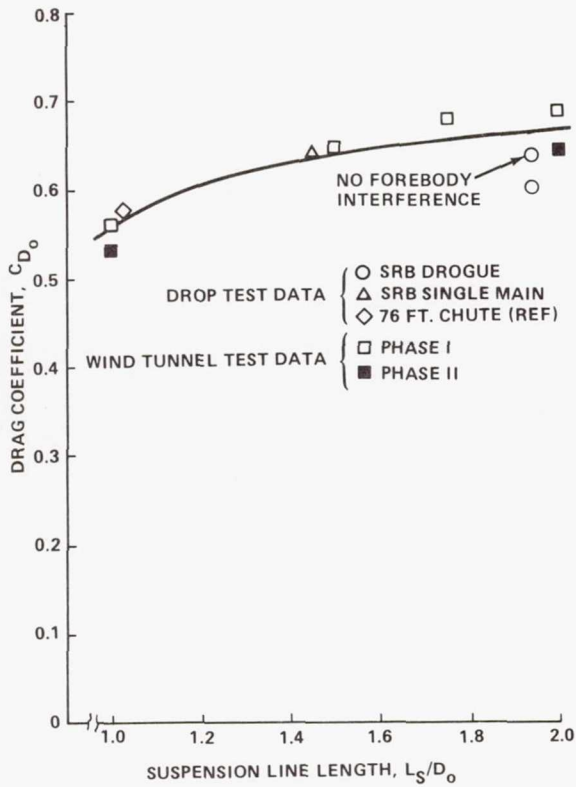

Figure 19. Drogue and Single Main Full Open Drag Performance.

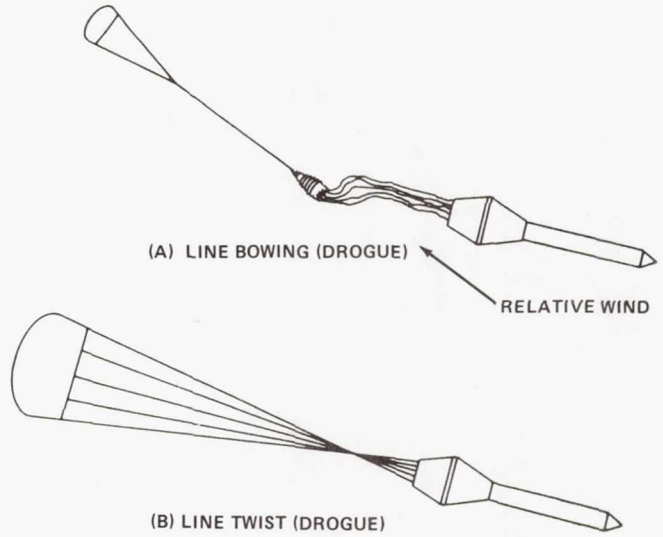
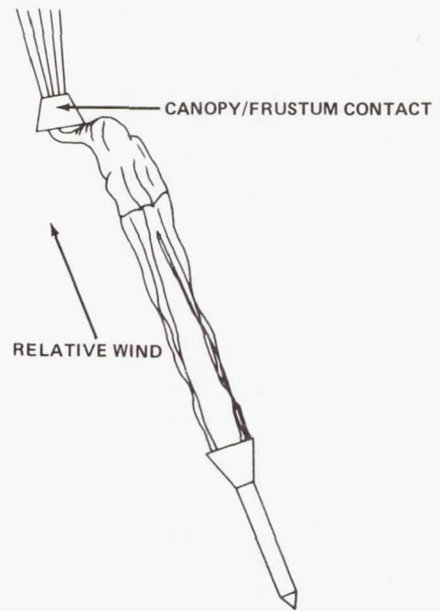

Figure 20. Drogue Test Drogue Deployment Anomalies.



INFLATION OVERTAKE (SINGLE MAIN)

Figure 21. Inflation Overtake During Single Main Test.

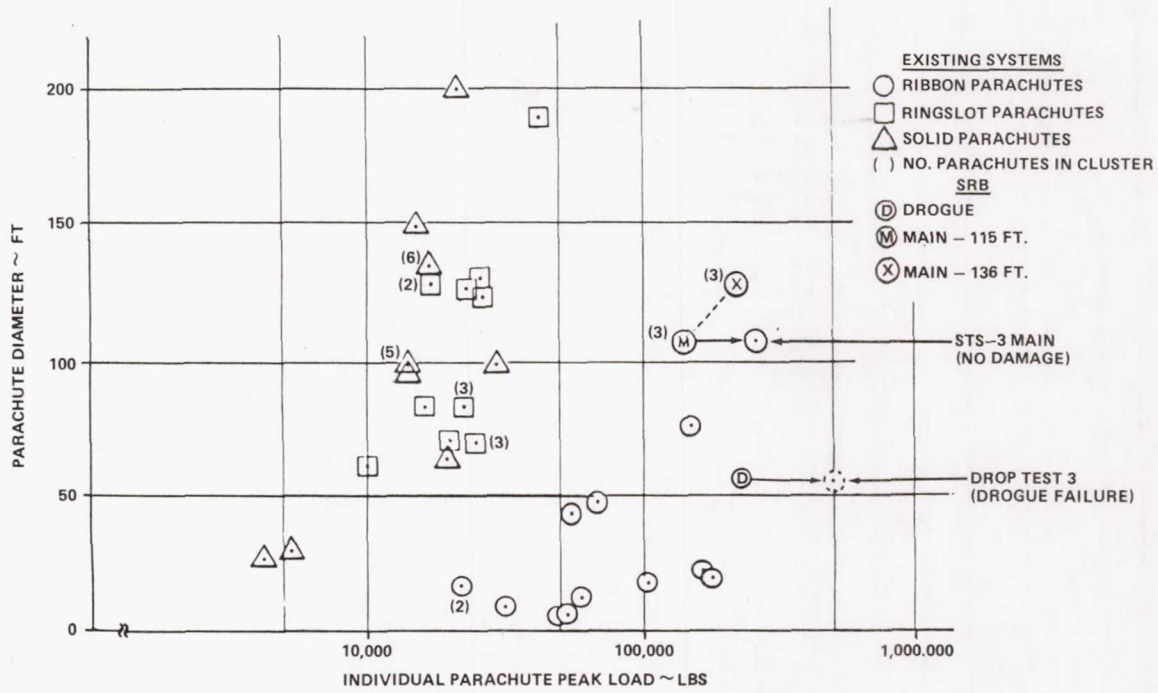

Figure 22. Parachute Experience, Peak Loads.

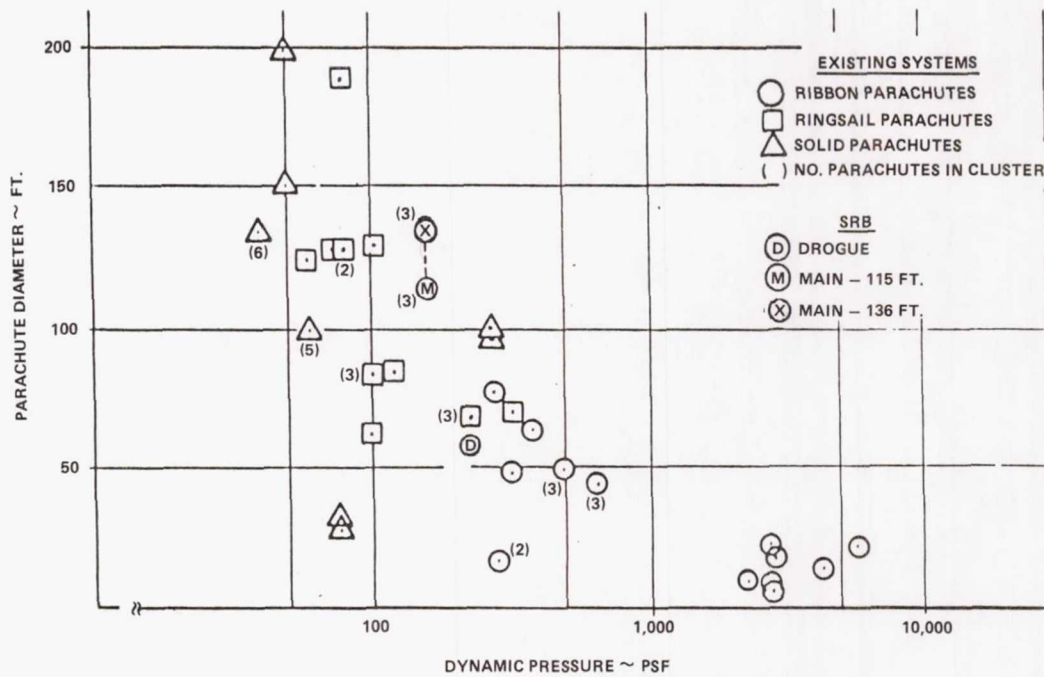

Figure 23. Parachute Experience, Deployment Dynamic Pressure.