

033
N85-16970

PAYLOAD TRANSPORTATION AT KSC

Michael E. Donahue
Planning Research Corp.
KSC, Florida

ABSTRACT

Cargo ground processing at John F. Kennedy Space Center (KSC) involves either a horizontal or vertical mode of assembly and processing of the Shuttle Transportation System (STS) payloads. Consequently, cargos are commonly referred to as horizontal or vertical payloads. The process flow for each mode requires different facilities and transportation requirements. Occasionally, a mixed mission cargo containing both horizontal and vertical payload elements will require a combination of horizontal and vertical transportation between facilities. This paper presents some of the engineering challenges and innovative solutions to satisfy the unique on-site payload transportation requirements at KSC. In particular, some of the more demanding design requirements of the Multiuse Mission Support Equipment are presented, and the resulting engineering designs and unique solutions are outlined.

INTRODUCTION

Horizontal cargos are assembled and tested in the Operations and Checkout Building (O&C) where all electrical, fluid, and mechanical interfaces between payload segments and Shuttle Orbiter are checked and tested. When integration and testing are complete, the payload is transported to the Orbiter at the Orbiter Processing Facility (OPF) and installed in the Orbiter payload bay. A vertical payload undergoes similar assembly and integration at the Vertical Processing Facility (VPF) and is then transported to the Shuttle launch pad where it is hoisted up to the Payload Changeout Room (PCR), a part of the Rotating Service Structure (RSS). It is then picked up by the payload ground handling mechanism (PGHM) for installation into the Shuttle Orbiter.

Mixed payloads require a combination of horizontal and vertical processing that culminates in the vertical transportation of the mixed cargo to the launch pad PCR. The rotation from horizontal to vertical is accomplished using two bridge cranes at the Vehicle Assembly Building (VAB). A flow chart of these requirements is shown in figure 1. The system created to accomplish the unique on-site transportation requirements for complete payload cargos and/or payload segments during line STS processing is called the Multiuse Mission Support Equipment (MMSE).

MMSE

The MMSE system was conceived to include a payload canister to structurally support and environmentally protect the payload during transportation operations, and a transporter to move the canister with the payload between KSC facilities for processing into the STS Orbiter. In addition, a complement of payload services to support the payload during transportation is required. It includes an electrical power unit, an environmental control unit, a fluid and gas services supply unit, and an instrumentation module to monitor the payload environment and critical payload measurements. The design and operational requirements for each element of the MMSE presented a unique engineering challenge.

PAYLOAD CANISTER

The payload canister must support all payloads that are possible for an STS mission; therefore it must accommodate a cargo volume of 15 feet in diameter and 60 feet long, with a maximum cargo weight of 65,000 pounds. The cargo can consist of one to five segments at one time, and the payload must be kept in a clean-room environment during transportation operations. The canister with payload has to be hoisted and rotated between the horizontal and vertical positions with only small deflections allowed in the canister structure so that loads are not induced into the payloads. This dictated a relatively stiff structure; however, gross weight is limited to 180,000 pounds because of the hoisting capacity at the launch pad for lifting the payload up to the PCR. Also, the canister must physically fit into all payload facilities (PCR, O&C, VPF, OPF) with its payload doors opened for removal of the payload.

The evolution of the canister design resulted in the configuration shown in figure 2, which is very similar in shape to the center body of the Shuttle Orbiter. The basic outside dimensions are 65 by 18 by 18 feet 7 inches high when horizontal (22 feet 7 inches high to the tip of the spike on the aft bulkhead). The inside geometry approximates that of the Shuttle Orbiter payload bay.

ORIGINAL DESIGN
OF POOR QUALITY

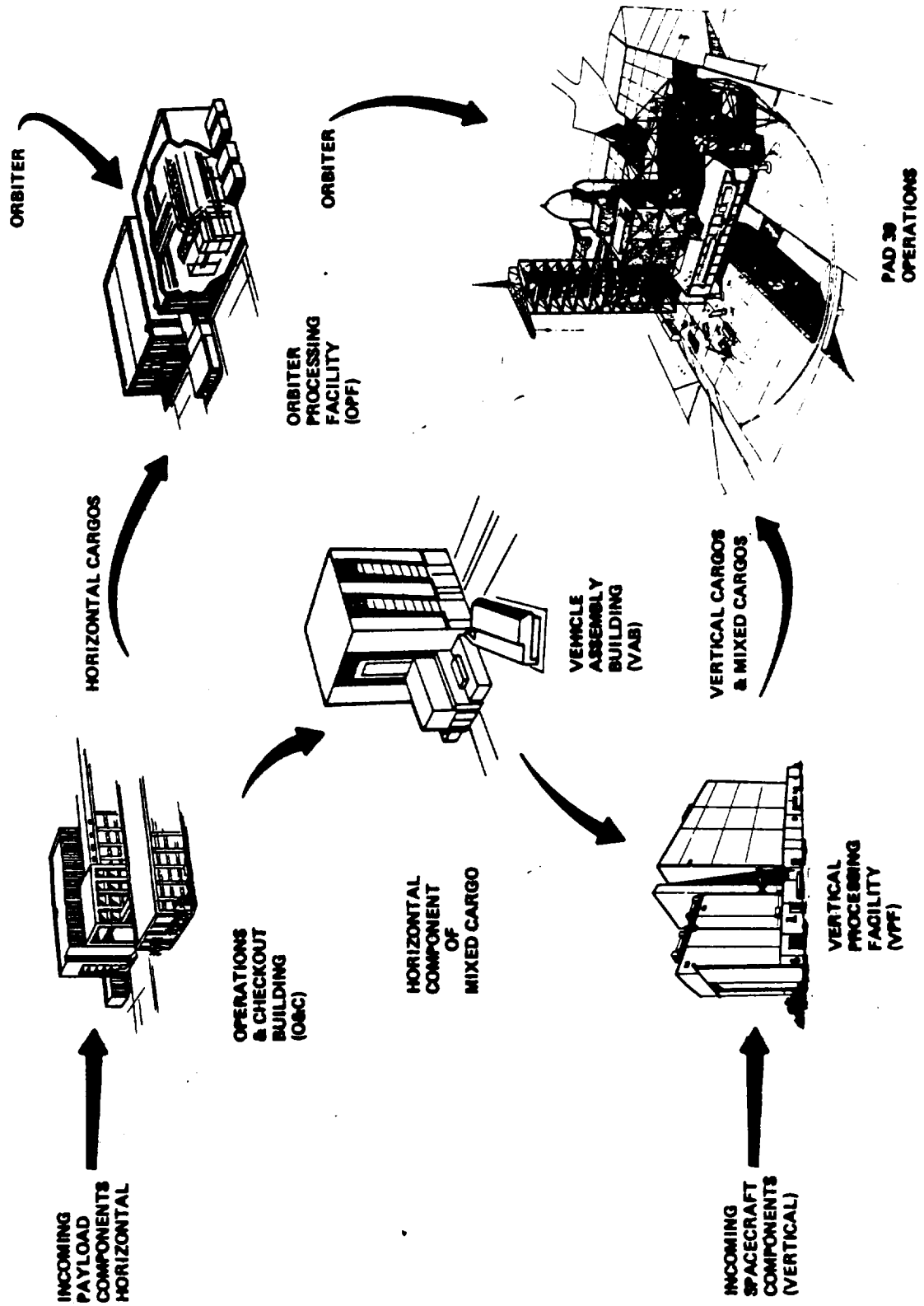

FIGURE 1. PAYLOAD TRANSPORTATION FLOW AT KSC

CE FOUR QUALITY

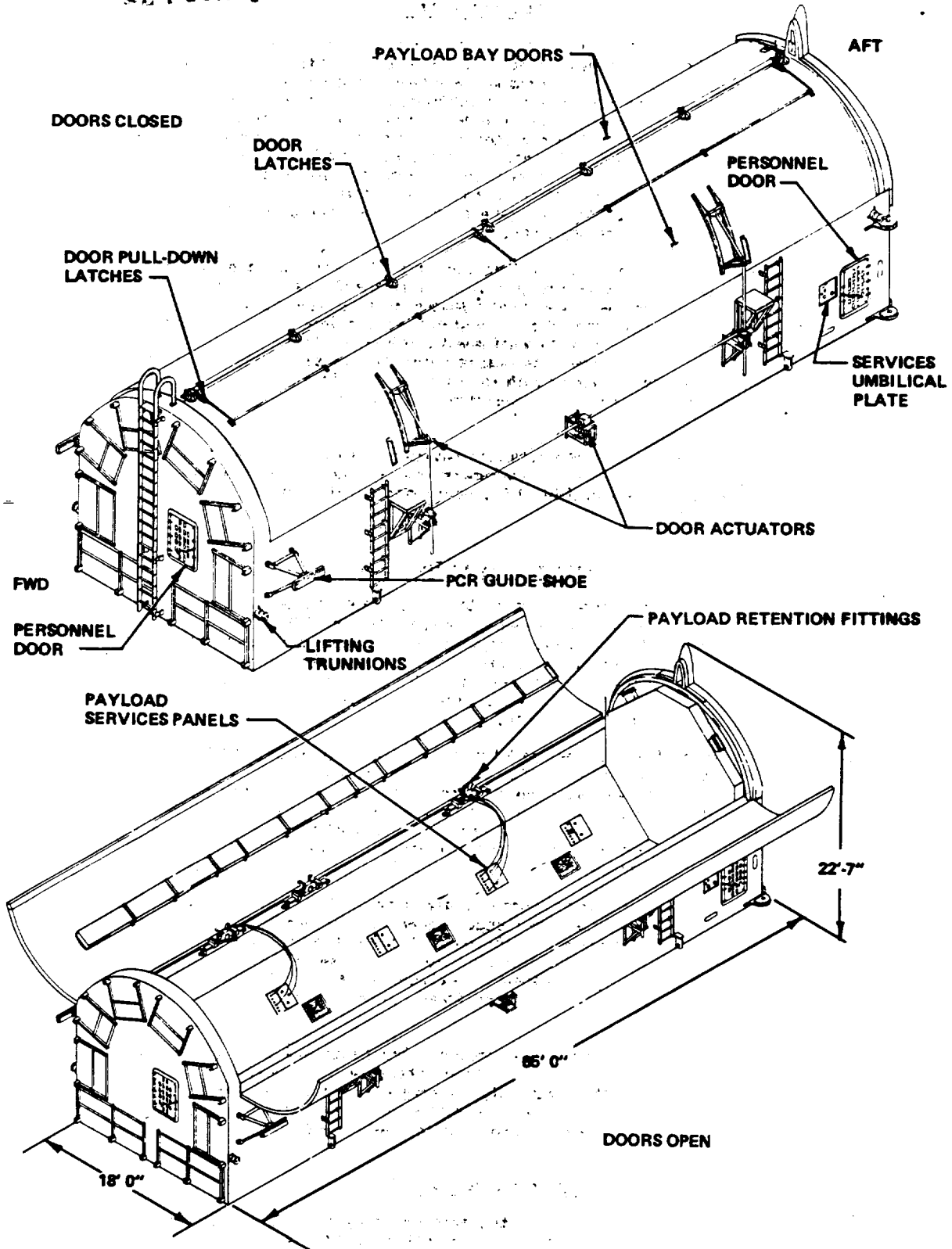

FIGURE 2. PAYLOAD CANISTER

Canister Structure

To satisfy the strength and particularly the rigidity requirements, the canister structural design consists of rigid steel "U"-shaped frames located approximately 10 feet apart with rigid steel bulkheads on each end of the payload bay. The frames are tied together with four steel rectangular box beams and a keel beam along the center of the canister bottom. Two of the box beams, called the longeron beams, along the side of the canister also provide support for the longeron trunnions of the payload, and they anchor the hinged end of the canister payload doors. The outside steel skin of the canister acts as a shear plate to stiffen the entire structure. To the inside of the skin are bonded blocks of rigid foam for insulation. The inside of the canister payload bay is lined with aluminum sheet to provide a floor for personnel access and to environmentally seal the payload bay. Two personnel hatches for access to the payload bay are provided, one through the forward bulkhead and one through the side of the structure at the aft end.

On the inside of the canister at each end, lifting trunnions are provided for both horizontal and vertical hoisting and for rotation between horizontal and vertical. All lifting is accomplished with two cranes except at the launch pad where a single 90-ton hoist is used to lift the vertical canister up to the PCR for payload transfer to the PGHM. To stabilize the canister during this lift, a pair of retractable guide shoes are provided on the forward end of the canister. These shoes "slip" into guide channels on both sides of the PCR to preclude swaying of the canister during hoisting. Since the weather seals around the payload door opening of the PCR must interface with the Shuttle Orbiter during STS operations, their geometry, as well as the geometry of the canister bulkheads, must duplicate the mold line of the Orbiter.

Installed in the aluminum floor of the canister payload bay are five payload interface panels that provide electrical power, fluid and gas, and instrumentation hookups for the payload. These panels are connected to umbilical panels on the outside of the aft end of the canister to which service is supplied from outside the canister.

Canister Payload Bay Doors

The canister payload bay doors posed a particularly challenging engineering problem in that they had to be thin in order to be opened in the space available at the PCR and in the OPF for removal of the payload and yet be strong and stiff enough to contribute to the structural integrity of the canister. When the payload doors are opened with the canister horizontal, the free edges must not sag into the payload envelope over their entire 60-foot length. With the doors closed, the doors needed to be an integral part of the load-carrying structure to provide rigidity to the canister, thus minimizing deflections during transportation of the payload.

The demanding requirements for the payload bay door design are satisfied by utilizing an aluminum monocoque structure very similar in construction to an airplane wing. The doors encompass the entire upper half of the canister; therefore, each door is configured into a quarter segment of a circle with an 8-foot radius and 5 inches thick. The design utilized "ribs" and "spars" bent from aluminum sheet and riveted between aluminum skins. The doors are attached to the lower structure by a continuous hinge between the door and the longeron beams of the lower structure. For a horizontal canister, the open doors provide a convenient personnel access along the longerons of the payload bay.

Special load-carrying latch mechanisms were designed to lock the two doors together along their interface at the top of the canister. The door latch mechanisms can be actuated from either end of the door by a torque tube that runs the length of the door. As a latch is locked utilizing an over-center mechanism, the torque is transferred to the next latch until all seven latches on the door are locked. Torque is applied to the torque tube by a ratchet turnbuckle-lever arm tool that is attached to either end of the torque tube. With the doors closed and locked, a pneumatically inflated seal is activated to environmentally seal the doors.

With the canister horizontal, the doors are opened using a screwjack mechanism that is mounted on the sides of the canister lower structure. The end of the screw is attached to a fold-down lever arm bracket mounted on the outside of the door. Two screwjacks and one air motor actuate each of the doors. With a vertical canister, the doors are operated manually with a technician pushing the doors by hand. During vertical operations, the door power mechanisms are folded out of the way and stored.

Payload Support Fittings

Payloads are supported in the canister in the same way they are supported in the Shuttle Orbiter. Primary longeron payload trunnions are supported in both the longitudinal (X_0) and vertical (Z_0) directions; secondary trunnions are supported only in the Z_0 direction. A split-block bearing housing

mounted on a slide rail is used such that the secondary fitting is allowed to slide along the X_0 direction, yet remain fixed in plus or minus Z_0 direction. For primary trunnion support, shear blocks are added to each side of the fitting to lock it to the rail for reaction of loads in the X_0 direction. Before insertion of a payload into the retention fittings, a spherical bearing is slipped onto the payload trunnion. During insertion of the payload, only the outer race of the GSE bearing contacts the housing of the retention fittings, thus protecting the polished surface of the payload trunnion.

The payload keel trunnion is supported in the canister between two longitudinal support rails that are mounted to the bottom of the canister payload bay. The keel trunnions require support only in the lateral direction (Y_0). To protect the surface finish on the keel trunnion and to act as a guide for the payload during insertion, a trunnion cover is placed on the keel trunnion prior to insertion of the payload into the canister.

PAYLOAD CANISTER TRANSPORTER

A vehicle to transport the payload canister required a motorized prime mover capable of transporting the canister in either a vertical or horizontal position at speeds up to 5 mi/h loaded (10 mi/h unloaded) and able to carry the necessary modules that provide services to the payload during transport in addition to the 90-ton maximum weight of the loaded canister.

To solve the transporter problem, technology was borrowed from the heavy construction industry -- particularly shipbuilding, where prime movers are used to transport large hull structures in the assembly of ships.

Description

The payload canister transporter, procured by performance specification, consists of a flat structural bed approximately 60 feet long and 22 feet wide, supported on twelve hydraulically lifted and steered bogies with four rubber tire wheels per bogie (see figure 3). Motive power is provided by hydraulic motors on the drive bogies. The transporter has two operator cabs, one on each end, and it can be controlled from either cab. The steering system, which is a servo-control system, allows the transporter to operate in a conventional Ackermann steering mode, a diagonal/transverse mode, or a carousel mode in which the transporter can turn about its own centerline axis. This steering capability allows operation in very close quarters and provides a transporter/canister positioning accuracy of ± 0.25 inches.

Transporter lifting power, steering power, and motive power is provided by hydraulics. The hydraulic pump system is driven mechanically by a diesel engine or, alternatively, by electric motors. This allows the transporter to be propelled by an internal combustion engine while over the road, by plug-in electrical power while inside clean-room payload facilities, and by an external electrical power generator in emergencies.

Transportation, Rotating, and Hoisting Operations

The bottom of the canister has four steel-plate pads on which the canister rests when horizontal and four similar pads on the aft bulkhead on which it rests when vertical. The transporter bed has mating steel pads which support the canister both horizontally and vertically. Holddowns are provided at the four support points to stabilize the canister when it is in the vertical transportation mode and to keep it from overturning. Vertical operations can proceed in winds up to 39 knots. The horizontal and vertical modes of transportation are shown in figure 4.

During transportation operations the MMSE payload services are provided to the payload through the umbilical panels on the canister. The umbilical lines, including supply and return air ducts for the environmental control system (ECS), are laid on the transporter deck. Sufficient length is provided for the drag-on lines so that they can remain attached and supplying services during hoisting and rotation operations at the VAB and during hoisting of the canister up to the PCR at the launch pad.

During hoisting operations at the launch pad when the vertical canister is lifted off the transporter by a single hook, the canister-payload center of gravity (cg) is placed under the hook by utilizing the bed-tilting feature of the transporter. To preclude the bottom (aft bulkhead) from "kicking-out" at the start of the lift, the transporter bed and the vertical canister are pitched over to allow the cg and the forward lifting trunnions on the canister to align with the lifting cable. The design of the canister is such that with any possible payload-canister cg the tilting is always in the same direction from vertical. The pad hoisting operation is shown in figure 5.

OF POST-REPAIR

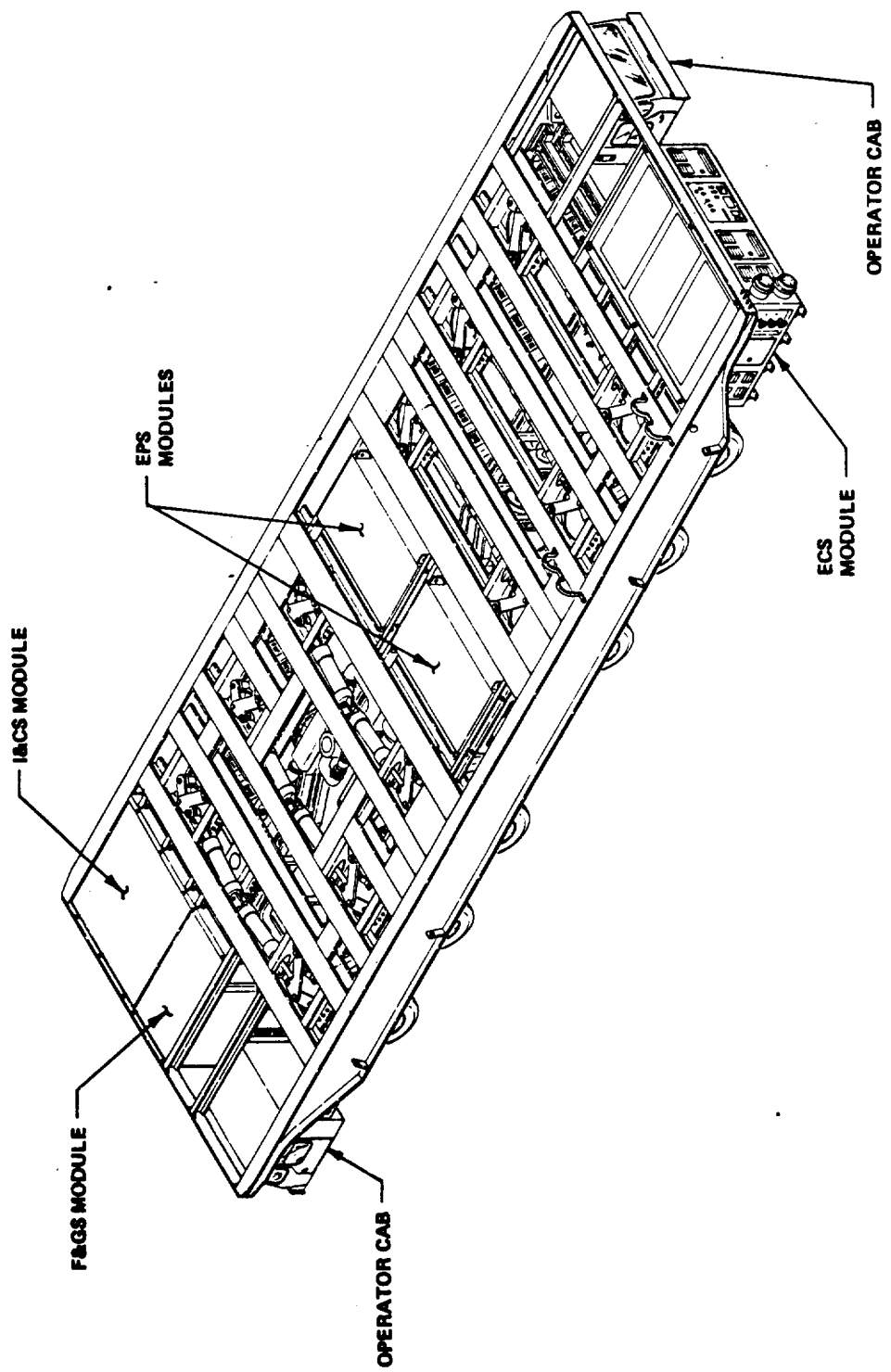

FIGURE 3. TRANSPORTER

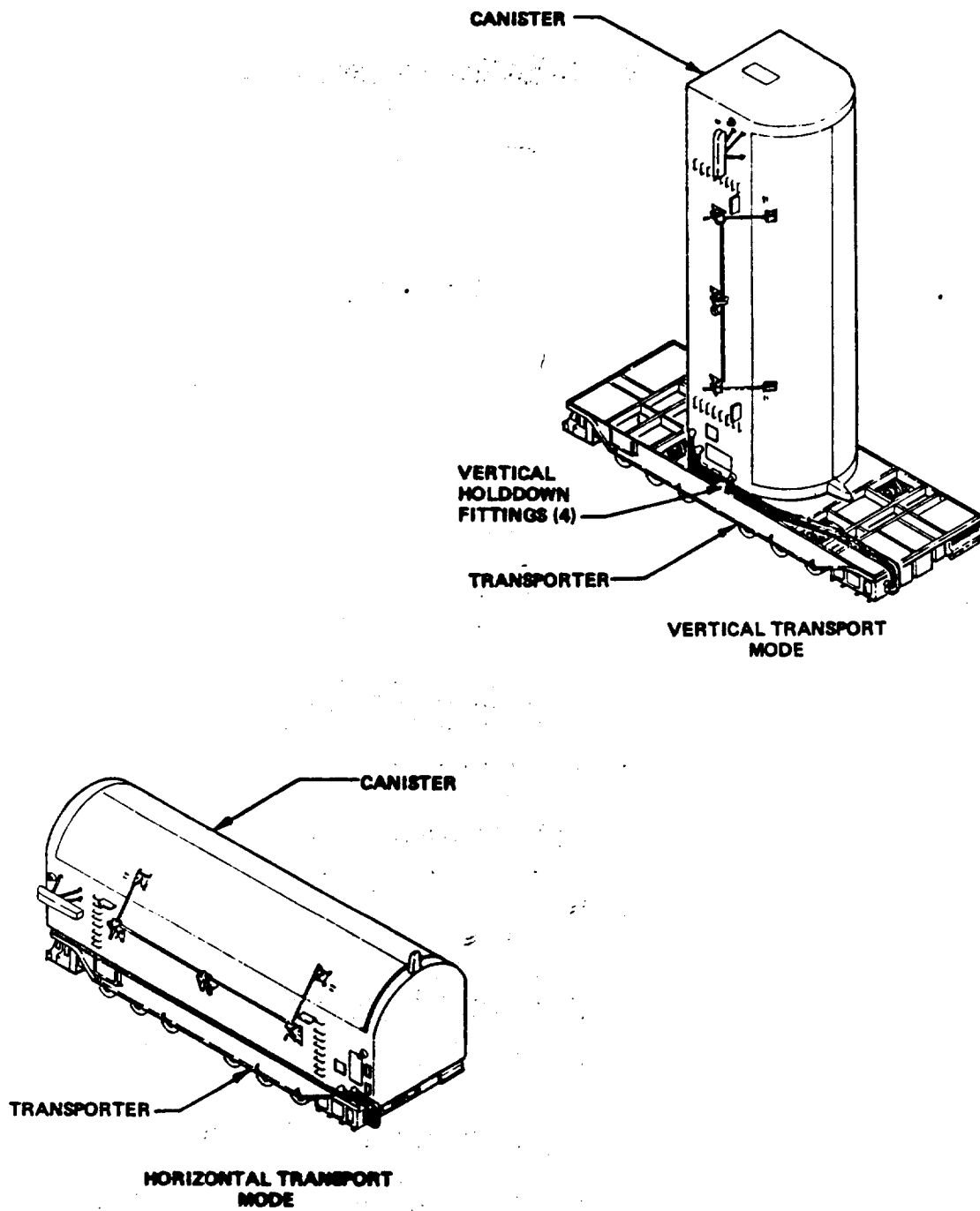

FIGURE 4. CANISTER-TRANSPORTER TRANSPORT MODES

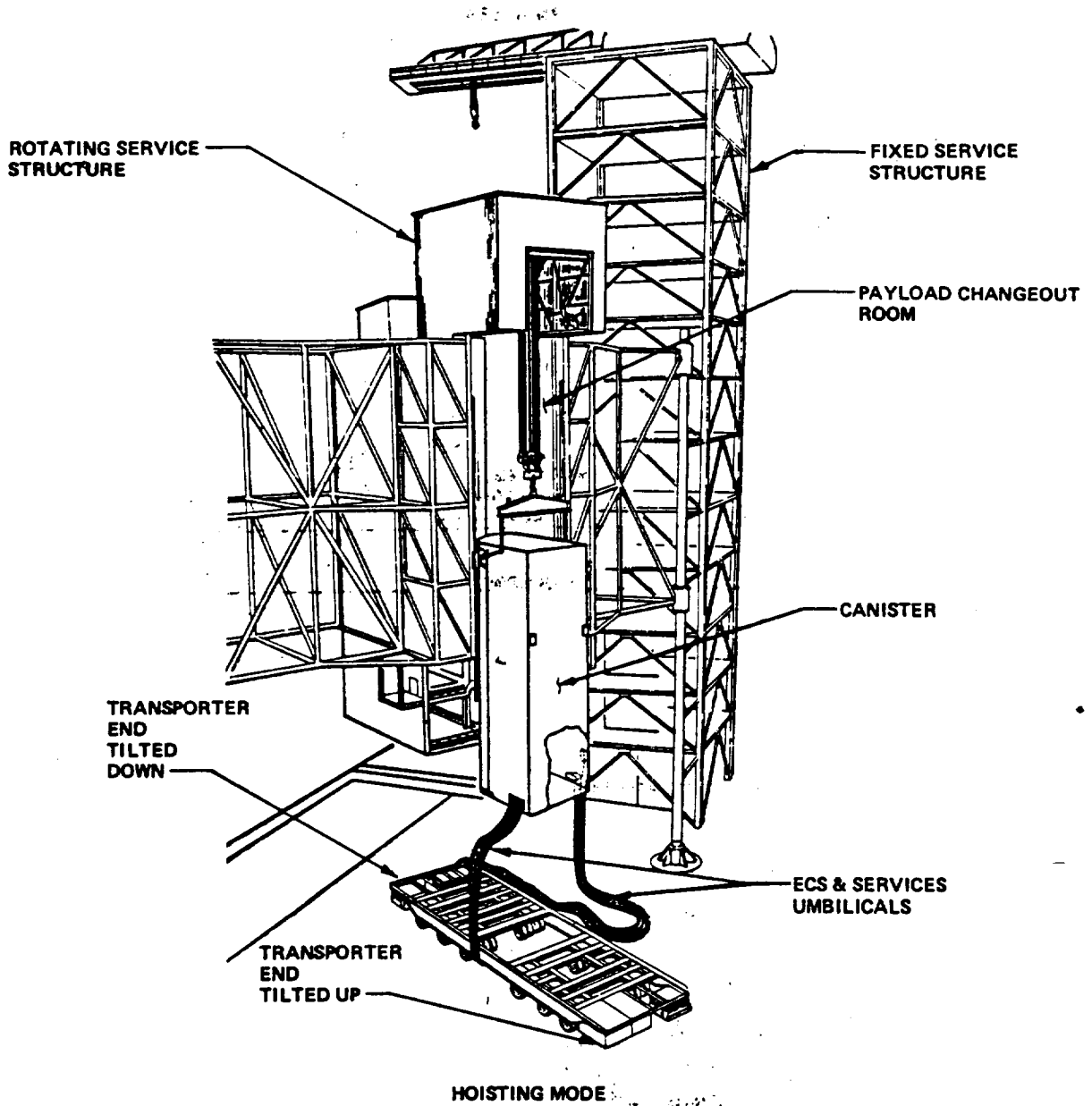

FIGURE 5. CANISTER HOISTING AT LAUNCH PAD

MMSE SERVICES SUBSYSTEMS

The electrical, environmental, fluid and gas, and instrumentation services required by the payload during transportation are supplied by separate subsystems. Because of the size and weight of these subsystems, it was necessary to keep them separate from the canister and to "pipe" the services to the canister through umbilical lines. The subsystem modules were uniquely packaged to fit under the bed of the transporter, allowing the most efficient use of space and maintaining a compact MMSE transportation system. The subsystem modules are identified in figure 3.

The ECS Module

The ECS module, mounted under the front end of the transporter bed, provides conditioned air to the payload through flexible supply and return ducts. Air is maintained at 65° to 75°F, 30% to 50% R.H., and Class-5000, with a flow rate of 75 to 150 pounds per minute.

The Fluid and Gas Subsystem (F&GS) Module

The F&GS module consists of K-bottles, a mounting rack, and a control panel. It can provide 30-pounds-per-square-inch-gage (psig) gaseous helium (GHe) and 30-psig gaseous nitrogen (GN₂) to the payload canister interface panel through umbilical hoses. This module is mounted under the aft center of the transporter bed.

The Instrumentation and Communication Subsystem (I&CS)

The I&CS consists of various instrumentation, electronics, recording devices, and displays packaged primarily in a module under the aft end of the transporter. The system provides a real-time display and recording capability for payload environmental measurements and monitors payload parameters during transportation. The module allows for an operator and observer to ride along inside the I&CS module during transportation.

The Electrical Power Subsystem (EPS)

The EPS consists of two diesel-engine-generator modules, distribution and control panels, and necessary cabling. The diesel generator modules are mounted one on each side of the transporter. They supply 120 V ac, 1.8 kVA single-phase power to the payload, ECS power, and I&CS power. In addition, the units can be used to drive the motor pumps of the transporter in case its mechanical drive engine should fail.

SUMMARY

Payload transportation at KSC is accomplished with a MMSE system. The payload canister, the canister transporter, and the services subsystem modules represent a unique system solution of some very demanding and challenging design requirements. The challenge was magnified because a complete Shuttle cargo is transported, not just individual payload components. The overall system goals were accomplished by combining these subsystems into a versatile tool for the STS program.

Many of the detail designs that went into the systems presented an engineering challenge. Those mentioned here, namely, the canister structure, payload doors, door-latch mechanisms and opening machinery, payload retention fittings, the transporter prime mover, and the subsystem modules, represent only a few of the many unique detail design problems that had to be solved. The MMSE system has achieved the system design requirements. This has been demonstrated successfully by tests using simulated payloads in and between all the payload facilities at KSC and by the successful transportation of entire cargos in support of seven STS launches to date.