

AEROJET ADVANCED ENGINE CONCEPT

L. Schoenman
Aerojet TechSystems Company

The future OTV requirements defined in figure 1 dictate the need for a highly versatile, highly reliable, reusable propulsion module. Aerojet's engine design approach (fig. 2) will provide a total thrust capability of 500 to 18 000 lbF, using one to six continuously throttleable engines. The selection of a nominal thrust level of 3000 lbF best fulfills the overall OTV requirements with a single propulsion system.

In order to attain maximum operational economy, space-basing will be essential. This requires a reusable, maintenance-free engine. The design features of this space-based engine are defined in figure 3.

A new engine cycle and its advantages, shown in figure 4, allow all the maintenance goals of figure 3 to be attained. Rubbing contact and interpropellant seals and purges, etc., are eliminated when GO_2 is used to drive the LO_2 pump, as shown in figure 5. The TPA design shown has only one moving part.

The use of both GH_2 and GO_2 to drive the turbines lowers the turbine temperatures to the values shown in figure 6. In addition, lower GH_2 temperatures and pressures allow improved chamber cooling and longer life.

The use of GO_2 as a turbine drive fluid, even at the low temperature of 400°F , is a concern which is being addressed through extensive materials testing. Friction rubbing and aluminum particle impact test results (fig. 7) indicate that proper selection of materials can eliminate the metals ignition experienced in the past. Stainless steel alloys are a notably poor choice for oxygen service.

Space-based engines will require an integrated control and health monitoring system (fig. 8) to improve system reliability and eliminate all scheduled maintenance.

Engine length is a major consideration when aero-assist return from GEO is employed. Examples of the importance of length are shown in figures 9 to 12.

Figures 13 and 14 show that the use of multiple engines has only minor impact on total propulsion system weight.

The issues associated with low-G transfers are presented in figures 15 to 17. Significant performance losses will develop when a single 15 000 lbF engine is operated at 500 to 1000 lbF. Also, the optimum mixture ratio shifts to the fuel-rich direction during throttling. This, in turn, increases stage volume and dry weight. Figure 17 indicates the relative performance benefit of one or two 3000 lbF engines operated at reduced thrust in comparison to one or two 15 000 lbF engines operating at the same thrust level. Figure 17 also demonstrates that the installation of three or four smaller engines versus two 15 000 lbF engines for a fail-operational capability always results in higher performance during nominal operation.

The superiority of multiple engines for mission success and man rating is shown in figures 18 and 19.

Figure 20 summarizes the advantages of the Aerojet 3000 lbF thrust engine design concept, which is shown in figure 21. Photographs of test hardware that closely parallels the designs and technology required for this engine are shown in figures 22 to 24.

Aerojet believes that all OTV propulsion requirements can be fulfilled with a single engine. Our program is designed to develop the technologies required to demonstrate that engine.

ADVANCED OTV REQUIREMENTS

- SPACE-BASING
- AERO-ASSIST
- LOW G TRANSFERS
- MANNED MISSIONS
- LOW COST PAYLOAD DELIVERY

Figure 1

AEROJET'S NEW CORE ENGINE CAN

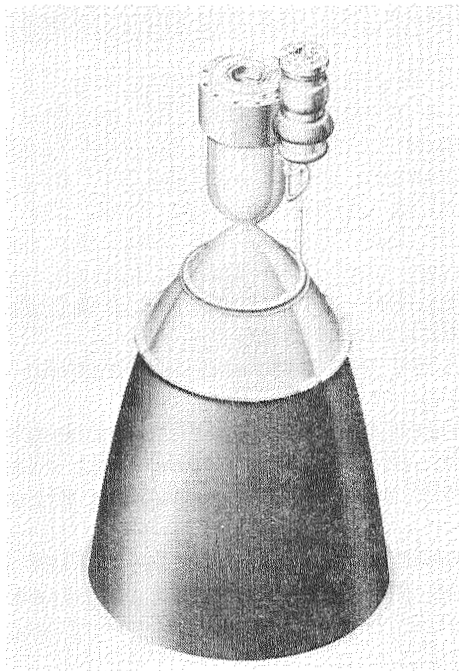

- 3000 lbF THRUST MODULES
- THRUST SELECTIVITY:
200-18,000 lbF

ORIGINAL PAGE IS
OF POOR QUALITY

Figure 2

NEW FEATURES ENABLE SPACE-BASING

- NON-WEARING SEALS AND BEARINGS
- NO INTERPROPELLANT SEALS OR PURGES
- NO GEAR BOXES
- LOWER OPERATIONAL TEMPERATURES
- INTEGRATED HEALTH MONITORS
- SPACE-REPLACEABLE UNITS

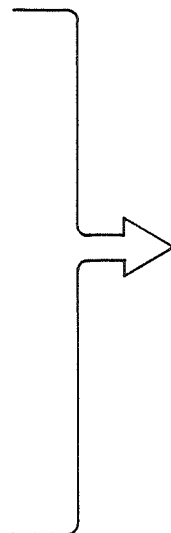

REUSEABILITY
NO MAINTENANCE

Figure 3

DUAL PROPELLANT EXPANDER CYCLE DELIVERS

- LOWER OPERATING TEMPERATURES
- CONTINUOUS THROTTLING
- SMOOTH STARTS
- LESS WEAR
- LONGER LIFE

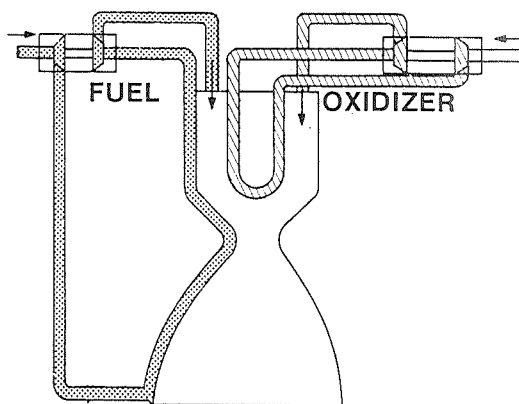

Figure 4

OXIDIZER PUMP



**ZERO
MAINTENANCE**

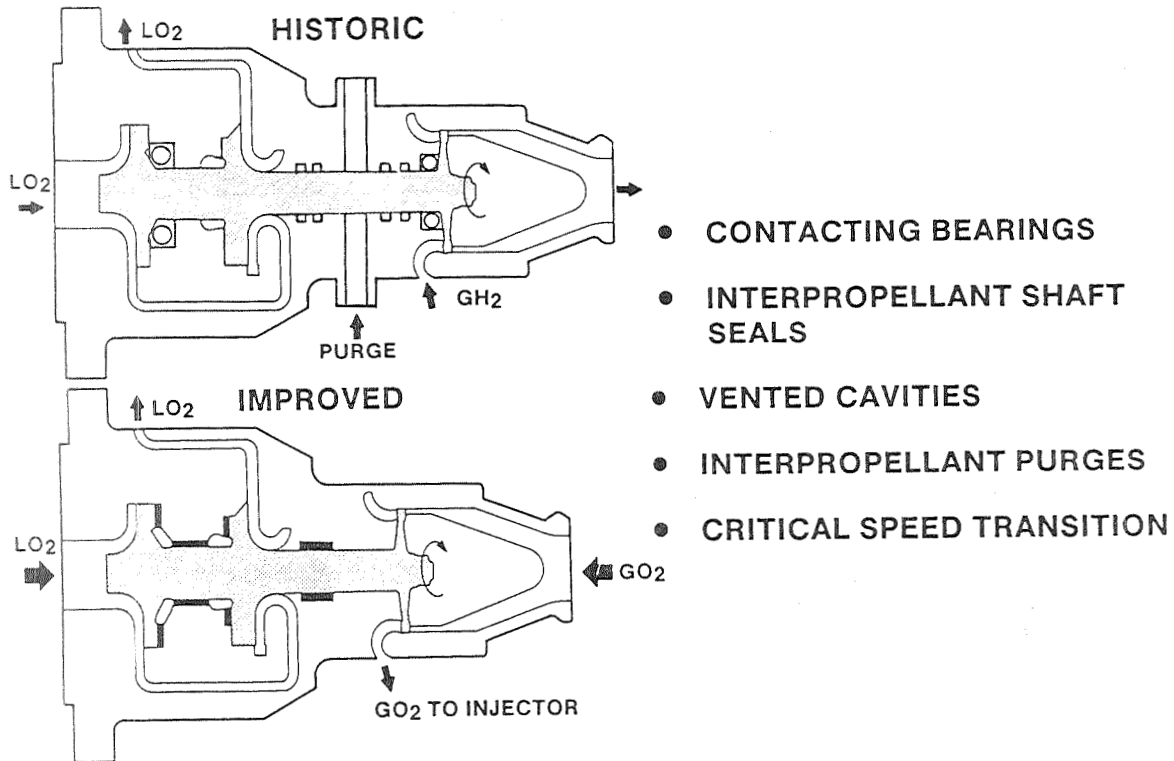

Figure 5

LOW TEMPERATURES YIELD GREATER MARGIN

- TURBINE TEMPERATURE 400° F
- THROAT TEMPERATURE 600° F
- RADIATION SKIRT TEMPERATURE <2000° F

Figure 6

Burn Factor Provides A Ranking Criterion For The Selection Of Materials For High Pressure, Gaseous Oxygen Applications

MATERIAL	BURN FACTOR	OBSERVATIONS
Zr Cu	35	NO IGNITION IN ANY TESTS > (790/1800°F)*
NICKEL 200	550	NO IGNITION WITHIN EXPERIMENTAL RANGE (825/2200°F)
SILICON CARBIDE	1145	NO IGNITION IN LIMITED TESTING
MONEL 400	1390	IGNITION ABOVE 1200°F FRT ONLY (800/1200°F)
K MONEL 500	2090	IGNITION ABOVE 1500 FRT (750/1500°F)
INCONEL 600	3226	IGNITION ABOVE 1100 (—/1100°F)
316 STAINLESS STEEL	4515	IGNITION IN ALL TESTS (450/800°F)
INVAR	5444	IGNITION IN ALL TESTS (675/340°F)
HASTELLOY X	7160	IGNITION IN ALL TESTS (725/750°F)

*(TEMPERATURES FROM PARTICLE IMPINGEMENT TEST/FRICTION RUBBING TEST. (FRT))

*FRT AT 1000 PSI 17,000 RPM

Figure 7

INTEGRATED CONTROL AND HEALTH MONITORING

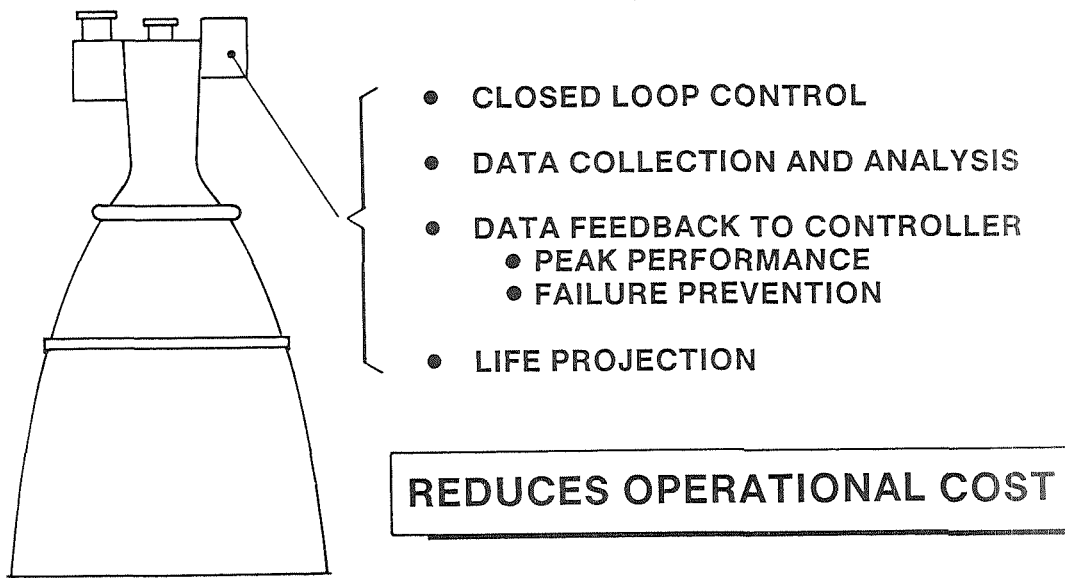

Figure 8

SMALL ENGINES FIT ALL AERO-ASSIST CONCEPTS

- SHORTER ENGINES ARE PREFERRED
- IDLE MODE OPERATION MAY BE REQUIRED

Figure 9

EQUAL PERFORMANCE IN A SMALLER PACKAGE

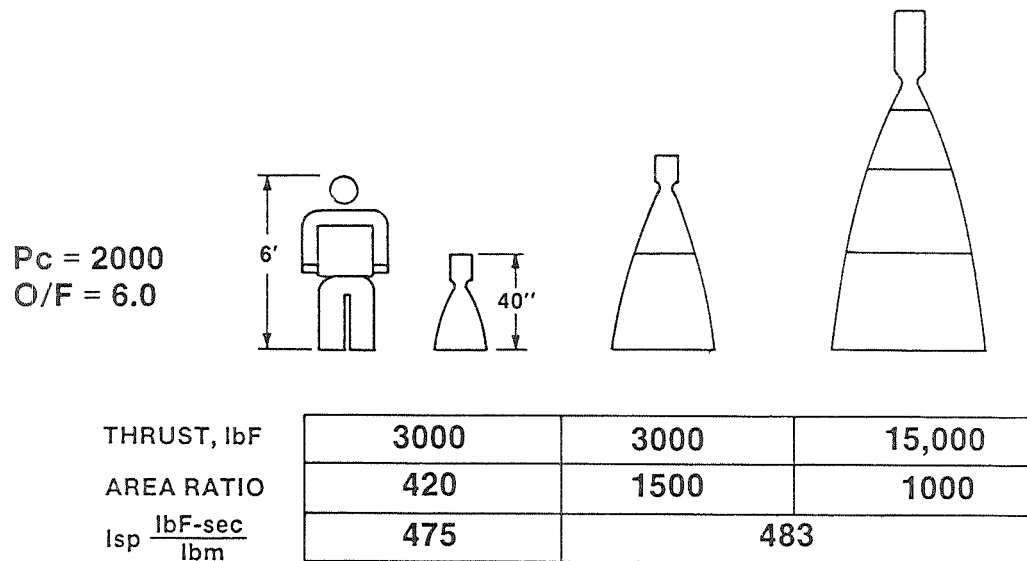

Figure 10

LENGTH IS CRITICAL FOR ALL AEROMANEUVERING CONCEPTS

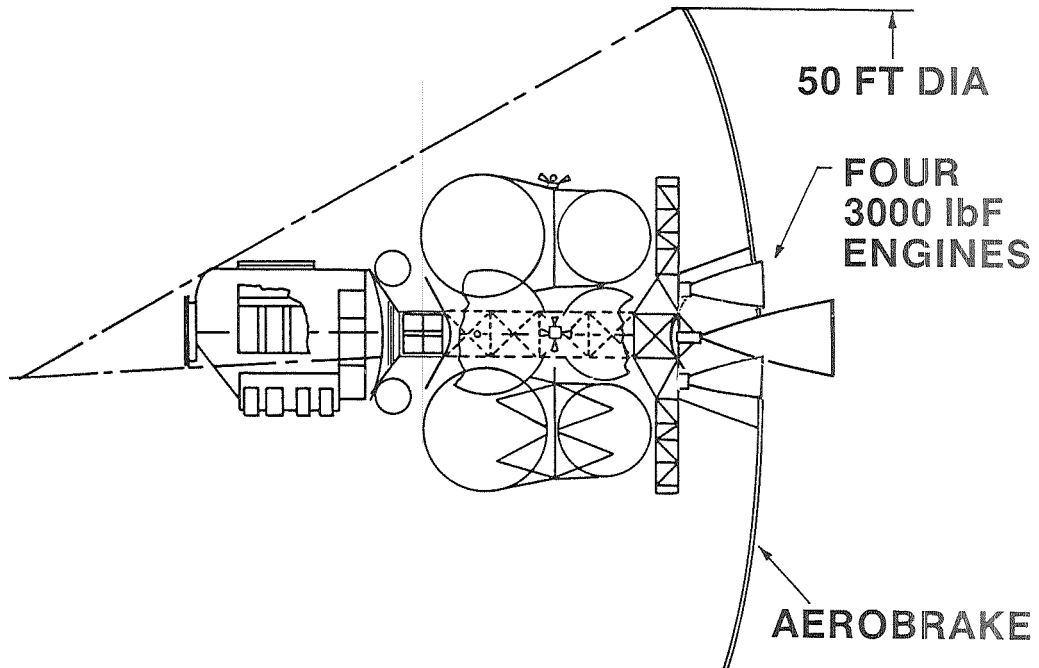

Figure 11

MINIMUM LENGTH AOTV

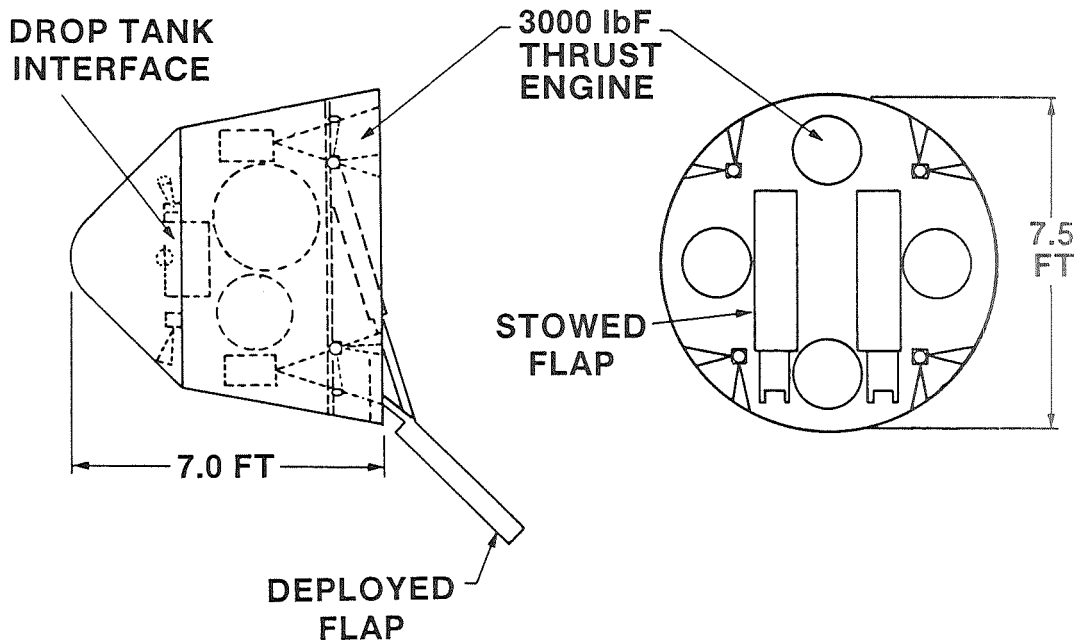

Figure 12

MULTIPLE ENGINES ALSO PROVIDE BOUNDARY LAYER CONTROL AND BOW SHOCK SKEWING

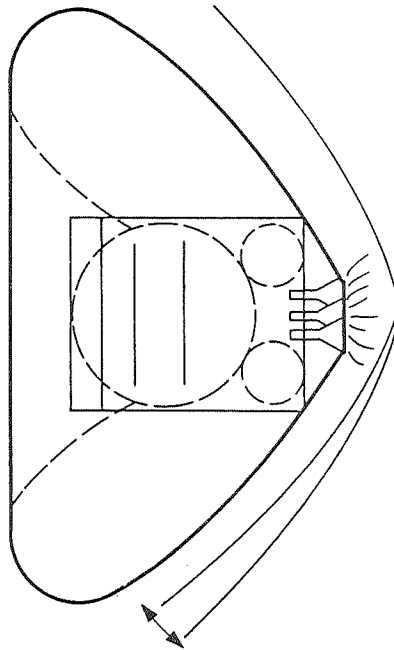

Figure 13

MAXIMUM WEIGHT DIFFERENCE FOR 6 ENGINES = 135 POUNDS

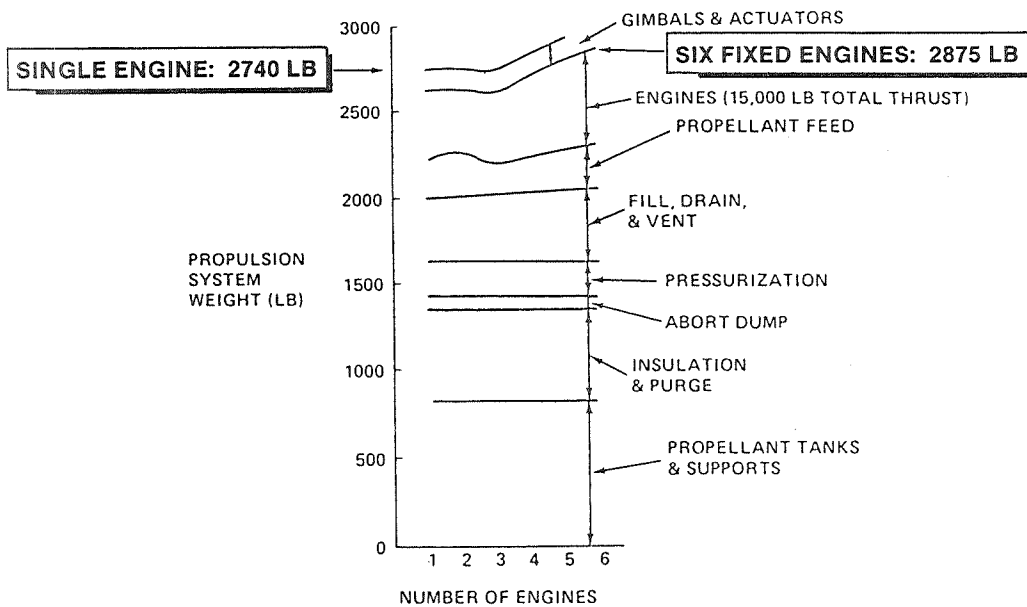

Figure 14

FOR LOW G TRANSFERS LOWER THRUST ENGINES OFFER

- SMALLER SIZE
- LOWER WEIGHT
- HIGHER PERFORMANCE
- SINGLE OR DUAL ENGINES
- THRUST SELECTIVITY 200 TO 3000 lbf

Figure 15

HIGH OPERATING PRESSURE → **LOWER PROPELLANT VOLUME
HIGHER PERFORMANCE**

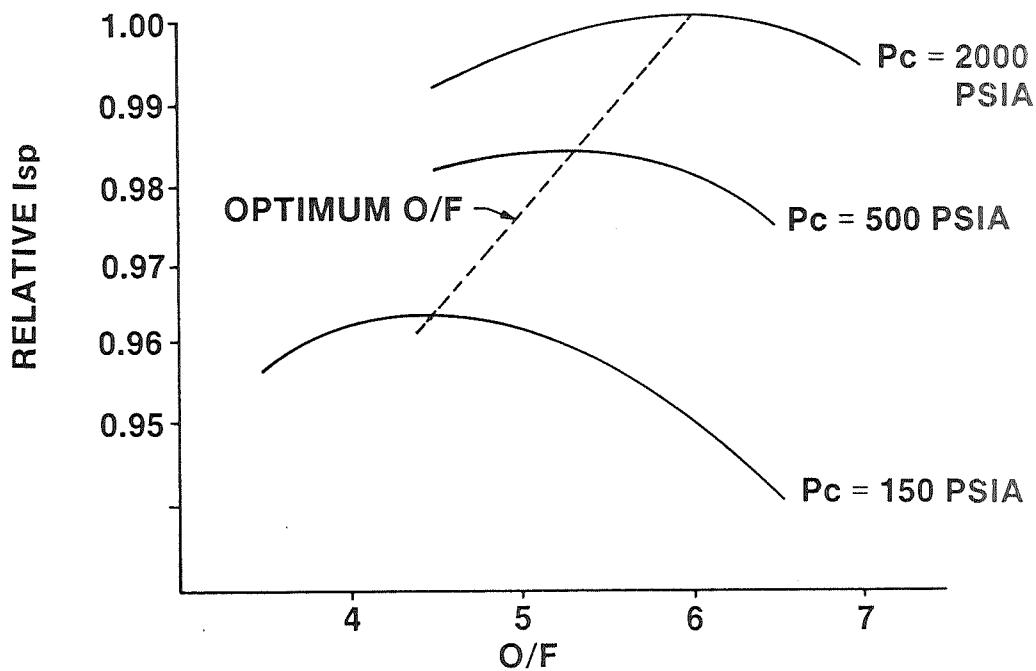

Figure 16

3000 LB THRUST MODULES YIELD HIGHER PERFORMANCE

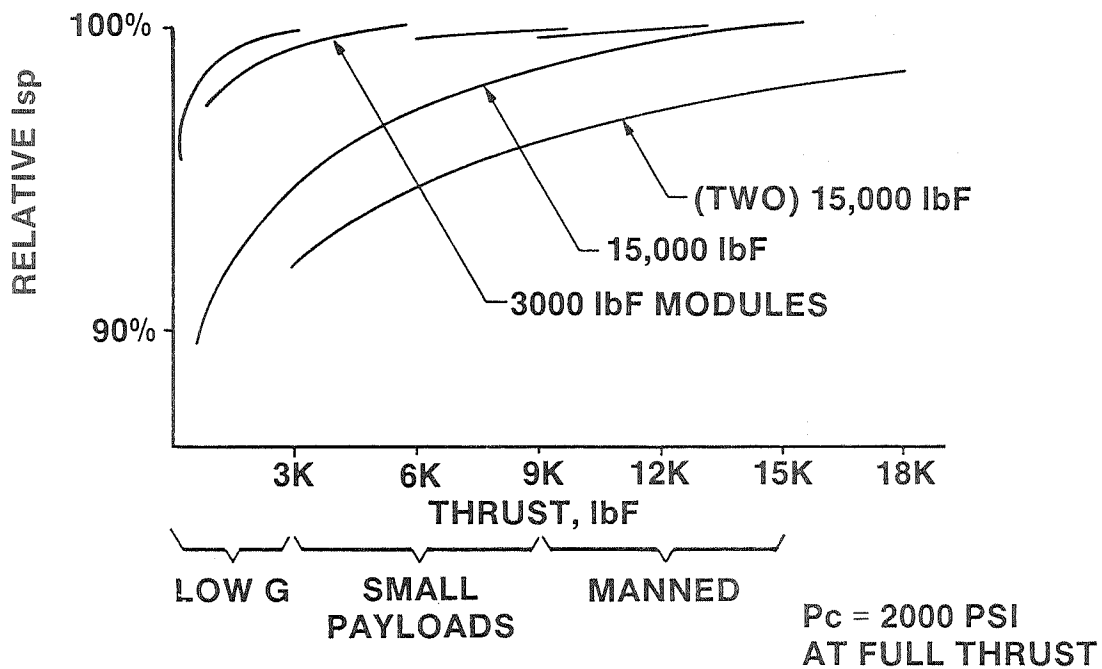

Figure 17

MULTIPLE ENGINES REQUIRED FOR MANNED MISSIONS

- MULTIPLE ENGINES =
- ENGINE-OUT CAPABILITY
- MISSION SUCCESS
- MINIMIZES COMPONENT REDUNDANCY
- MINIMIZES DEPENDENCE ON HEALTH MONITOR SYSTEM

Figure 18

MULTIPLE ENGINES ENHANCE MISSION SUCCESS AND CREW SAFETY

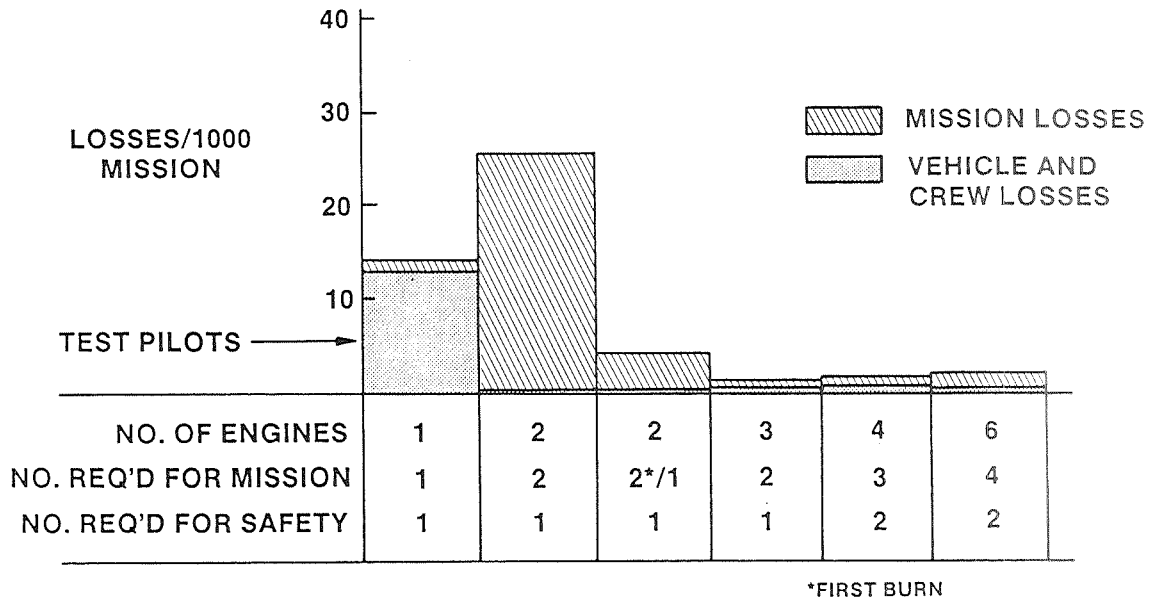

Figure 19

AEROJET APPROACH PROVIDES LOW COST PAYLOAD DELIVERY

- SMALL SIZE
- LOWER DEVELOPMENT COST
- LOWER UNIT COST
- BETTER PACKAGING
- HIGHER PERFORMANCE
- MODULAR APPROACH
- OPTIMUM THRUST FOR ALL MISSIONS
- ONLY ONE ENGINE DEVELOPMENT REQUIRED
- MULTIPLE ENGINES
- MISSION SUCCESS

Figure 20

AEROJET'S NEW CORE ENGINE

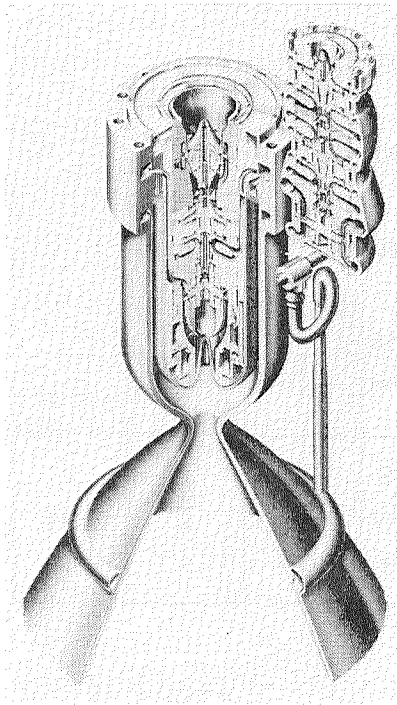

ORIGINAL PAGE IS
OF POOR QUALITY

Figure 21

17 TESTS - GH_2/GO_2 ANNULAR TCA

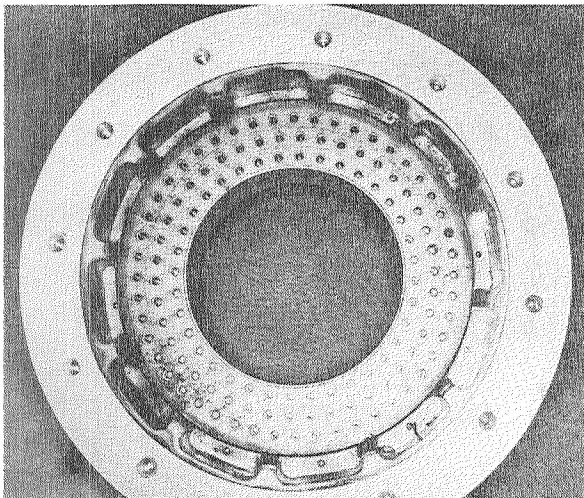

- STABLE COMBUSTION
- HEAT TRANSFER AND PERFORMANCE DATA

C0184 007

Figure 22

CALORIMETER INNER CHAMBER

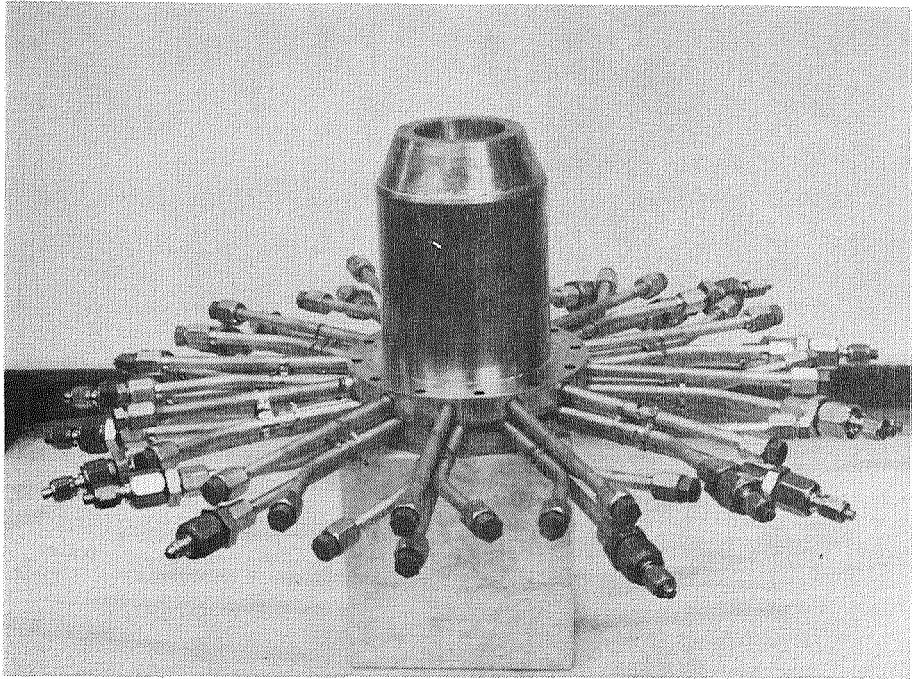

Figure 23

60,000 RPM LOW SPECIFIC SPEED PUMP. $N_s = 700-1000$

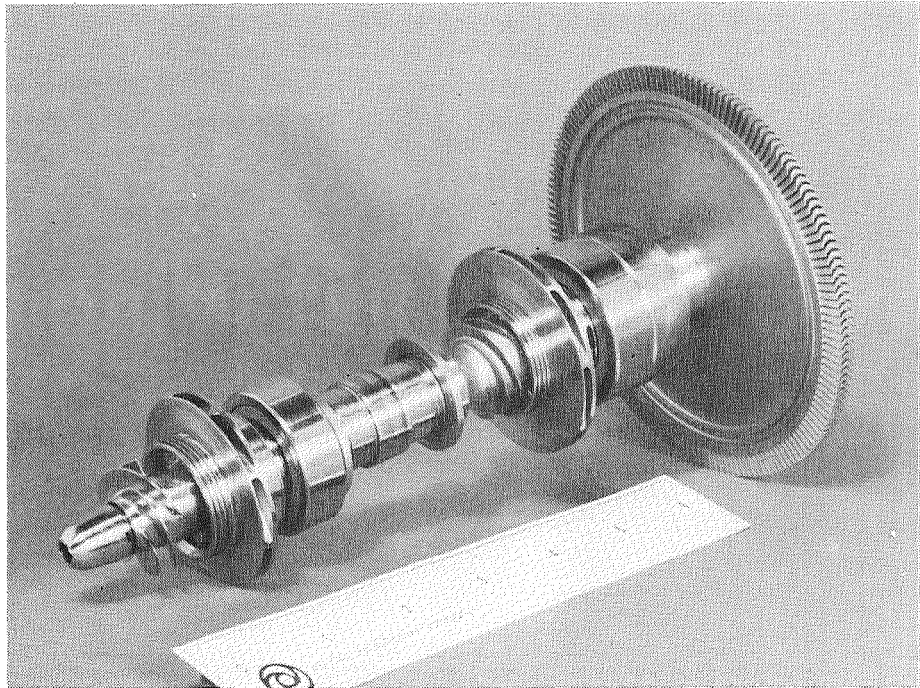

Figure 24