

NASA-CP-2364 19850012029

NASA Conference Publication 2364

Applications of Tethers in Space

Volume 1

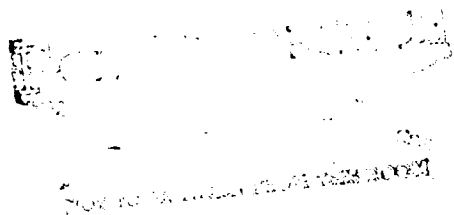

LIBRARY COPY

MAR 23 1985

LANGLEY RESEARCH CENTER
LIBRARY, NASA
HAMPTON, VIRGINIA

*Proceedings of a workshop held in
Williamsburg, Virginia
June 15-17, 1983*

NASA

NASA Conference Publication 2364

Applications of Tethers in Space

Volume 1

*Alfred C. Cron, Compiler
General Research Corporation
McLean, Virginia*

Proceedings of a workshop sponsored by the
National Aeronautics and Space Administration,
Washington, D.C., and George C. Marshall Space
Flight Center, Huntsville, Alabama, and held in
Williamsburg, Virginia
June 15-17, 1983

NASA
National Aeronautics
and Space Administration
Scientific and Technical
Information Branch

1985

PREFACE

The 1983 Applications of Tethers in Space Workshop was an important forum for diversity of scientific and engineering opinion about the prospective uses of tethers in space. The technical arguments, given in the resulting Workshop Proceedings, supporting the development of the Tethered Satellite System are carefully reasoned and thoroughly sound. The scientific uses of the new facility are striking in their importance and breadth. Overall, we are very impressed with the sheer enthusiasm which pervades the entire document. It is clear that this cooperative U.S./Italian project has struck many resonances with a broad range of potential users of space platforms.

In fact, we wonder if the support given to the Tethered Satellite System isn't an expression of technical pleasure derived from the quickening pulse of mankind's ability to explore and utilize space. The opportunity to conduct operations from multiple platforms orbiting Earth can be viewed as another liberation step in our ability to move freely throughout the solar system and, perhaps, even into deep space.

The presentations contained within the Workshop Proceedings consider many different applications. Some of the topics are clearly more mature, in a technical and scientific sense, than others. Yet, this is the time to have speculative thoughts and novel ideas. The passage of time and confrontations with technical and fiscal reality will winnow the collection into a harvest of rich technical productivity.

We commend these proceedings to the reader as an important document demonstrating both current engineering and scientific perceptions concerning tethers in space and as a guide to many ideas whose time will come in the future.

Peter Banks
Carlo Buongiorno
1 December 1983

FOREWORD

The "Applications of Tethers in Space" Workshop was held at Williamsburg, Virginia, on 15-17 June 1983. The workshop was sponsored by the Office of Space Transportation (OST) and Marshall Space Flight Center (MSFC) of the National Aeronautics and Space Administration (NASA). The goals of the workshop were:

- To provide a focus for, and a review of, technological opportunities and requirements for the application of tethers in space.
- To brief aerospace planners and specialists on the nation's space program plans for the Tethered Satellite System (TSS) and on NASA's current efforts for developing effective, tether applications.
- To delineate a data-base of methods, techniques, and technologies which may prove effective in the design and development of tether systems for use in the space program.
- To aid in planning OST's tether applications program by identifying applications technological needs and promising research topics and approaches.
- To insure that all parties involved are aware of significant programs in industry, academia, government and internationally which may be helpful in determining optimal tether roles for future space missions.

The workshop served to continue the dialogue between the tether community and the space program's planners, researchers, and operational staff. The focus for continuing this dialogue will be a tether research program which is being supported by NASA's Office of Space Transportation to begin in 1984. The goal of the research program is to develop an empirical data base for determining application optimal roles, procedures, and interfaces for a tether space program. This includes ground operations as well as on-orbit operations.

This report contains copies of all the presentations given (Sessions I-IV) and the reports of the working group (Session V). In most cases, the presentations were made with overhead transparencies, and these have been published two to a page. The author's explanatory text is presented on the facing page.

1 December 1983
Washington, D.C.

TABLE OF CONTENTS

	<u>PAGE</u>
<u>VOLUME I</u>	
<u>SESSION I - INTRODUCTION</u>	1-1
Welcome; Orientation and Purpose	1-3
- William R. Marshall	
Marshall Space Flight Center	
Keynote Address	1-17
- Ivan Bekey	
NASA Headquarters	
<u>SESSION II - TETHERED SATELLITE SYSTEM</u>	2-1
Project Overview	2-3
- Jay Laue	
Marshall Space Flight Center	
Tether Deployment	2-21
- Donald Crouch	
Martin-Marietta, Denver	
Satellite Overview	2-35
- Gianfranco Manarini	
PSN/CNR	
Satellite System Description	2-57
- Marcello Vignoli	
Aeritalia	
<u>SESSION III - FUNDAMENTALS AND APPLICATIONS</u>	3-1
Tether Fundamentals	3-3
- Chris Rupp	
Marshall Space Flight Center	
Science Applications I	3-19
- Franco Mariani	
University of Rome	
Science Applications II	3-31
- James Murphy	
NASA Headquarters	
Electrodynamic Interactions	3-49
- Noble Stone	
Marshall Space Flight Center	

	<u>PAGE</u>
Transportation Applications I	3-67
- Joseph Carroll	
California Space Institute	
Transportation Applications II	3-79
- Enrico Lorenzini	
Aeritalia	
Artificial Gravity	3-95
- D. Bryant Cramer	
NASA Headquarters	
Constellations	3-109
- David Criswell	
California Space Institute	
Technology and Test	3-123
- Paul Siemers	
Langley Research Center	
"Where Are We Going With Tethers?"	3-129
- Professor Giuseppe Colombo	
Harvard-Smithsonian	
<u>SESSION IV - PANEL CHAIRMEN SUMMARIES</u>	4-1
Science Applications	4-3
- Bob Hudson	
NASA Headquarters	
Electrodynamic Interactions	4-11
- Dick Taylor	
Harvard-Smithsonian	
Transportation Applications	4-23
- Max Hunter	
Lockheed	
Artificial Gravity	4-39
- George Butler	
McDonnell Douglas Astronautics Corporation	
Constellations	4-51
- Frank Williams	
Martin-Marietta-Michoud	
Technology And Test	4-63
- Paul Siemers	
Langley Research Center	

VOLUME 2

<u>SESSION V - PANEL REPORTS</u>	5-1
Science Applications - Franco Mariani, Bob Hudson	5-3
Electrodynamic Interactions - Dick Taylor, Noble Stone	5-11
Transportation Applications - Max Hunter, Ernesto Vallerani	5-31
Artificial Gravity - George Butler, Bob Freitag	5-87
Constellations - Frank Williams, Giovanni Rum	5-163
Technology and Test - Col. Norman Lee, Paul Siemers	5-193

APPENDICES

A ATTENDEES	A-1
B PANEL MEMBERSHIP	B-1
C MEETING AGENDA	C-1
D REFERENCES	D-1

SESSION I
INTRODUCTION

WELCOME; ORIENTATION AND PURPOSE

William R. Marshall
Marshall Space Flight Center

WELCOMING ADDRESS

WILLIAM R. MARSHALL
DIRECTOR, PROGRAM DEVELOPMENT
GEORGE C. MARSHALL SPACE FLIGHT CENTER

Within NASA we have been talking about tether satellites for about six or seven years, and the history of the tethers in space ideas goes back to well over eighty years. Presently, we are in the process of discovering the many useful applications of tethers in space.

We have started the development of a tethered satellite which will be released by a winch carried in the Shuttle orbiter. A downward release will enable upper atmospheric research and an upward release will allow the study of electrodynamic interactions between tether and space plasma.

There is much room for new ideas with tethers in space. Many new concepts have already been generated, and I hope that this workshop will generate many more tether applications together with an assessment of the scientific benefits as well as of technology issues and of the engineering feasibility of the various concepts.

I believe that the discussions we are going to have during the next few days will be very fruitful, particularly, because we have people with ideas and expertise as members of the six panels that have been established.

During the first morning we will hear about ideas and concepts that are currently being studied. I hope that these presentations will set the stage for real productive panel sessions over the next two days and stimulate new thoughts and applications. On the last day we will concentrate on the best approaches and listen to the findings of the individual panels.

Let me mention a few of our past efforts in tether applications (Fig. 1). We had a Stranded Astronaut Rescue Study many years ago which investigated the capturing of astronauts by a long tether. During 1967 we studied a tethered Apollo Telescope Mount versus one that was hard-docked to the Skylab. During this workshop we will hear more about the use of tethers in lieu of hard-docking between two spacecraft. During the Gemini program we also carried out a tether experiment.

SHUTTLE/TETHERED SATELLITE SYSTEM

PRIOR ACTIVITIES:

- STRANDED ASTRONAUT RESCUE STUDIES (BUOY ON A TETHER)
 - MARQUARDT CORPORATION (1963)
 - ANALYTICAL MECHANICS ASSOCIATES, INC. (1972)
- APOLLO TELESCOPE MOUNT/ORBITAL WORKSHOP STUDIES (TETHER VS. HARD DOCKING)
 - MARSHALL SPACE FLIGHT CENTER (1967)
- GEMINI XI AND XII TETHER EXPERIMENTS (1967) (TETHERED GEMINI AND AGENA VEHICLES)
- "SKYHOOK" PROPOSAL FOR LOW ALTITUDE TETHERED SATELLITE ORBITAL RESEARCH
 - SMITHSONIAN ASTROPHYSICAL OBSERVATORY - DR. COLOMBO (1974)
- TETHER TENSION CONTROL LAW (FEASIBILITY OF DEPLOYING, STABILIZING AND RETRIEVING)
 - MARSHALL SPACE FLIGHT CENTER (1975)
- ADDITIONAL FEASIBILITY STUDIES (DYNAMICS, CONTROL, THERMO, COMMUNICATIONS)
 - MARSHALL SPACE FLIGHT CENTER (1976)

Figure 1.

In 1974 Dr. Colombo, who is participating in this workshop, developed the initial idea of a tethered satellite which we have been refining over the years and which now has reached the hardware stage. Since 1975 we developed tension control laws and dynamic simulation models (Fig. 2) of long tethers which are rather involved and complex. This was done in cooperation with the Martin Marietta Aerospace Corporation and with Ball Aerospace. We also worked with the European Space Agency and with the Smithsonian Institution since the late '70's. Quite a number of feasibility studies and facility requirement definition took place.

SHUTTLE/TETHERED SATELLITE SYSTEM

PRIOR ACTIVITIES (CONT'D)

- TETHER SYSTEM DYNAMICS ANALYSES (CONFIRMED EARLY STUDIES)
 - EUROPEAN SPACE AGENCY (1976)
 - WHF AND ASSOCIATES (1976)
 - SMITHSONIAN ASTROPHYSICAL OBSERVATORY (1977)
- CONCEPTUAL DESIGN STUDY (PHASE A IN-HOUSE)
 - MARSHALL SPACE FLIGHT CENTER (1976)
- FACILITIES REQUIREMENTS DEFINITION TEAM ESTABLISHED (1978)
- PHASE B STUDIES
 - BALL AEROSPACE AND MARTIN MARIETTA
 - COMPETITIVE AND PARALLEL
 - 1977-80
- COOPERATIVE PROGRAM WITH ITALY

Figure 2.

These efforts were headed by Dr. Peter Banks with various members of other universities (Fig. 3). In addition to the facility requirements definition, this group identified specific investigations and detailed scientific requirements (Fig. 4). The final report represented the justification for the NASA administration to start the tethered satellite system project (Fig. 5). A final study, still in progress with Martin Marietta Aerospace Corporation, resulted in the first hardware construction. There is in existence now a cooperative program with the Italian government.

TETHERED SATELLITE SYSTEM
FACILITY REQUIREMENTS DEFINITION TEAM (FRDT)

<u>SPONSOR:</u>	NASA OSS/MSFC	
<u>CHAIRMAN:</u>	DR. PETER BANKS	UTAH STATE UNIVERSITY
<u>MEMBERS:</u>	DR. JAMES BURCH	SOUTHWEST RESEARCH INSTITUTE
	DR. GEORGE CARRIGAN	UNIVERSITY OF MICHIGAN
	DR. PAUL COLEMAN	UNIVERSITY OF CALIFORNIA, L.A.
	DR. GUISSSEPI COLOMBO	SMITHSONIAN ASTROPHYSICAL OBSERVATORY
	DR. FREDRICK CRAWFORD	STANFORD UNIVERSITY
	DR. DAVID EVANS	NOAA SPACE DISTURBANCE LABORATORY
	DR. MARIO GROSSI	SMITHSONIAN ASTROPHYSICAL OBSERVATORY
	DR. KENNETH HARKER	STANFORD UNIVERSITY
	DR. PAUL HAYS	UNIVERSITY OF MICHIGAN
	DR. ROBERT HELLIWELL	STANFORD UNIVERSITY
	DR. ROBERT HOFFMAN	GODDARD SPACE FLIGHT CENTER
	DR. UMRAN INAN	STANFORD UNIVERSITY
	DR. ROBERT REGAN	PHOENIX CORPORATION, RESTON, VIRGINIA
	DR. RAYMOND ROBLE	NATIONAL CENTER FOR ATMOSPHERIC RESEARCH
	MR. NELSON SPENCER	GODDARD SPACE FLIGHT CENTER
	DR. NOBIE STONE	MARSHALL SPACE FLIGHT CENTER
	DR. JAMES WALKER	UNIVERSITY OF MICHIGAN
	DR. P.R. WILLIAMSON	UTAH STATE UNIVERSITY

Figure 3.

TETHERED SATELLITE SYSTEM
FACILITY REQUIREMENTS DEFINITION TEAM (FRDT)

OBJECTIVES:

1. IDENTIFY SCIENTIFIC INVESTIGATIONS WHICH WILL BENEFIT FROM THE TETHERED SATELLITE SYSTEM (TSS).
2. DEFINE DETAILED SCIENTIFIC REQUIREMENTS OF THE SHUTTLE/TSS SYSTEM FOR THESE INVESTIGATIONS. INCLUDE ENGINEERING AND OPERATIONAL ASPECTS.
3. SUGGEST SEVERAL SCIENTIFIC INVESTIGATIONS FOR FIRST, PREDOMINANTLY ENGINEERING DEMONSTRATION, MISSION.
4. PREPARE REPORT SUMMARIZING CONCLUSIONS AND RATIONALE. SUITABLE FOR OSS PEER REVIEW PROCESS.

EMPHASIS IS TO BE ON OSS SCIENCE DISCIPLINES (ELECTRODYNAMICS, SPACE PLASMA PHYSICS, ATMOSPHERIC PHYSICS)

Figure 4.

TETHERED SATELLITE SYSTEM

FRDT CONCLUSIONS AND RECOMMENDATIONS:

- THE TSS REPRESENTS AN IMPORTANT OPPORTUNITY TO CONDUCT UNIQUE CLASSES OF SCIENTIFIC INVESTIGATIONS.
- NASA SHOULD PROCEED WITH DEVELOPMENT OF TSS CAPABLE OF ACCOMMODATING A BROAD RANGE OF USERS.
- INVESTIGATION OPPORTUNITIES SHOULD BE AVAILABLE THROUGH NASA ANNOUNCEMENT OF OPPORTUNITY PROCESS.
- REUSABLE, MULTIPLE INSTRUMENT CARRIERS SHOULD BE DEVELOPED AND PROVIDED FOR ELECTRODYNAMIC AND FOR ATMOSPHERIC EXPERIMENTS.
- OPPORTUNITY SHOULD BE PROVIDED FOR TSS EXPERIMENTS TO OPERATE IN CONJUNCTION WITH SHUTTLE SYSTEMS, PALLET-BASED INSTRUMENTS AND SPACELAB INSTRUMENTS.

Figure 5.

About five years ago we carried out a tether satellite system mission workshop (Fig. 6) at the University of Alabama in Huntsville. There we developed payload requirements and assessed technology concepts. Candidate missions were discussed and their implementation requirements.

The tethered satellite system is now becoming an on-going program and it is appropriate to look for expansions of the idea. That is the purpose of this workshop and we hope that out of our discussions will come more ideas and applications.

SHUTTLE/TETHERED SATELLITE SYSTEM

TETHER MISSIONS (REF. NASA/UAH TSS WORKSHOP, MAY 1978)

- REQUIREMENTS FOR PAYLOAD DESIGN.
 - BASED FIRMLY ON WELL DEVELOPED TECHNOLOGY.
 - FAIRLY SIMPLE.
 - YIELD INTERESTING AND APPLICABLE SCIENTIFIC RESULTS.

- PRELIMINARY CANDIDATES
 - TETHERED MAGNETOMETER MISSION.
 - ELECTRODYNAMIC TETHER
 - CHEMICAL RELEASE
 - TETHERED STUDIES OF THE UPPER ATMOSPHERE.

- POSSIBLE LATER MISSIONS:
 - GRAVIMETRY
 - POWER GENERATION
 - SIMULATION OF PLANETARY ELECTRODYNAMICS
 - PLASMA WAKE AND SHEATH STUDIES
 - LOWER ATMOSPHERIC DYNAMICS
 - GAS DYNAMICS AND WAVE STRUCTURE
 - MULTIPLE MEASUREMENTS ALONG A SINGLE TETHER

Figure 6.

The large variety of tether applications in space required a categorization in order to be manageable. We have five categories and in addition, science and applications, which cut across the various categories. They are now here represented by six panels (Fig. 7).

TETHER APPLICATIONS IN SPACE

WHAT ARE TETHER APPLICATIONS?

- BASED ON THE ONGOING TETHERED SATELLITE SYSTEM PROGRAM A LARGE VARIETY OF ALTERNATE APPLICATIONS OF LONG TETHERS IN SPACE HAVE BEEN PROPOSED.

- THESE TETHER APPLICATIONS FALL INTO FIVE CATEGORIES:
 - ELECTRODYNAMIC INTERACTIONS (E.G. ELECTRIC POWER AND FORCE GENERATION)
 - TRANSPORTATION (E.G. CHANGE OF SPACECRAFT ORBIT)
 - ARTIFICIAL GRAVITY (E.G. FRACTIONAL AND VARIABLE GRAVITY ENVIRONMENT)
 - CONSTELLATION (E.G. TETHER CONNECTED MULTIPLE SPACECRAFT)
 - TECHNOLOGY AND TEST (E.G. HYPERSONIC MODEL TESTING IN UPPER ATMOSPHERE)

- IT IS HOPED TO FIND MANY MORE AS YET UNDEFINED APPLICATIONS WITH POTENTIAL BENEFITS.

Figure 7.

In our NASA program planning we want to select an early flight demonstration mission. We expect that this workshop will select at least one that can be implemented by 1986 (Fig. 8).

TETHER APPLICATIONS IN SPACE PROGRAM DEVELOPMENT

PROGRAM SOURCES:

- CONTRACTED STUDIES AND NASA IN-HOUSE EFFORTS
- TETHER APPLICATION IN SPACE WORKSHOP
- NASA TETHER APPLICATIONS IN SPACE INTER-CENTER TASK GROUP

PROGRAM PLANNING

- PLANNING GOAL: FY1986 SELECTED PROOF OF CONCEPT FLIGHT EXPERIMENT
- PLAN CONTENT:
 - THEORETICAL FEASIBILITY
 - ENGINEERING DESIGN FEASIBILITY
 - TECHNOLOGY REQUIREMENTS
 - COST EFFECTIVENESS POTENTIAL
 - DESIGN AND CONCEPT VERIFICATION EXPERIMENTS
- PLANNING STATUS:
 - PROGRAM MILESTONE ASSESSMENT AND REQUIRED RESOURCES ESTIMATION
 - PROGRAM PLAN DEVELOPMENT IN PROGRESS

Figure 8.

Our workshop objectives are shown in Fig. 9. We want to develop a first order assessment and feasibility of the various concepts. We also want recommendations for future actions and want to find areas which need technology advancements. Finally, we want to stimulate industry and government planners to consider the unique properties of tethers in the design of future missions.

Workshop Objectives

- Identify potential applications for tethers in space.
- Develop a first order assessment of the feasibility and benefits of tether applications.
- Recommend future actions necessary to enable tether applications including required technology advancements.
- Stimulate industry and government planners to consider the unique properties of tethers in designs for future missions

Figure 9.

The six panels that have been formed have two co-chairmen each to coordinate and head the activities of the next few days (Fig. 10). Each panel will accomplish the four tasks listed (Fig. 11).

Workshop Panels

Electrodynamic Interactions

Richard Taylor (Smithsonian) Nobie Stone (MSFC)

Transportation

Max Hunter (Lockheed) Ernesto Vallerani (Aeritalia)

Artificial Gravity

George Butler (MDAC) Bob Freitag (NASA HDQ)

Constellations

Frank Williams (Martin-Marietta) Giovanni Rum (PSN/CNR)

Technology and Test

Col. Frank Redd (USAF) Paul Siemers (LaRC)

Science Applications

Franco Mariani (Italy) Bob Hudson (NASA HDQ)

Figure 10.

Panel Tasks

The workshop will be organized in six parallel panels. The goals of each are:

- Identify new applications for tethers in space.
- Analyze and critique all identified tether applications relative to their practicality, cost benefit, and operational requirements.
- Identify those critical design, performance, or operational factors that must be included in the evolution of the practical feasibility of each tether application.
- Provide recommendations to NASA for the continued evaluation and definition of the tether applications identified.

Figure 11.

The results of this workshop will provide an input to the NASA Tether Applications in Space Task Group under the direction of Georg von Tiesenhausen. The objective of this group is to develop a program plan on tether applications in space for the years 1984 through 1987 (Fig. 12). This plan will become available in September of this year.

TETHER APPLICATIONS IN SPACE TASK GROUP

OBJECTIVE: DEVELOPMENT OF A PROGRAM PLAN FY84-87

GROUP COMPOSITION

<u>CENTER</u>	<u>NAME</u>	<u>REMARKS</u>
MSFC	GEORG von TIESENHAUSEN	CHAIRMAN
LeRC		
JPL	PAUL PENZO	
JSC	MILTON CONTELLA	
LaRC	PAUL SIEMERS III	
NASA-OSF	EDWARD BRAZILL	CONSULTANT

PROGRAM PLAN AVAILABLE: SEPTEMBER 1983

Figure 12.

KEYNOTE ADDRESS

Ivan Bekey
NASA Headquarters

TETHERS OPEN NEW SPACE OPTIONS

Background

In 1895 Tsiolkovsky suggested connecting large masses in space by a long thin string to exploit weak gravity-gradient forces. Since the inception of the space program, gravity-gradient stabilization has been applied to satellites, but with a short rigid boom instead of a long string. Tethering has been tried only in Gemini 6 and 7 experiments with a short tether and in some long-antenna-wire experiments using little end-mass. The idea of long tethers for rescuing stranded astronauts has also been studied, but was not until 1974 that someone seriously considered applying the concept to heavy masses with very long tether strings--G. Colombo of Italy working at the Smithsonian Astrophysical Observatory (SAO). Since then NASA, supported by Colombo, SAO, the science community, and two contractors--Martin Marietta Denver Aerospace and Ball Aerospace--have defined the dynamics, design, and scientific uses of a 500-kg system to be tethered 100 km from the Space Shuttle. Recently this has developed into a cooperative program between Italy and NASA.

While this test will demonstrate again the versatility of the Shuttle and give us a unique reusable experiment platform that can reach atmospheric and ionospheric regions heretofore denied, the true potential of the "tether" lies in the many astonishing concepts which arise by exploiting its static, dynamic, and electric properties. This paper discusses some concepts now identified. Many more will surely be conceived. A few already have the benefit of dynamics calculations, simulations, or sizing study, though most have yet to seriously address guidance, system operation, and programmatic. Some may not survive such design or critical comparison with alternatives for achieving the same ends. But the intent of this article is to encourage consideration of tethers in novel solutions; thus the applications will be shown in their best light.

The tethering concept is deceptively simple. On the surface some of the following concepts may appear to violate laws of physics--may seem to be manufacturing energy or to "lift themselves by their own bootstraps." However, a short discussion on the fundamentals of tether action will dispel such impressions.

Tether Fundamentals

An elementary tether system has "dumbbell" form, with two masses connected by the tether. The top mass experiences a larger centrifugal than gravitational force, being higher than the orbit of the CG, whereas the reverse occurs at the bottom mass (see Fig. 1). Displacing the system from the local vertical generates restoring forces at each mass, tending to return the system to local vertical. The system will remain aligned with the local vertical or "gravity gradient" vector.

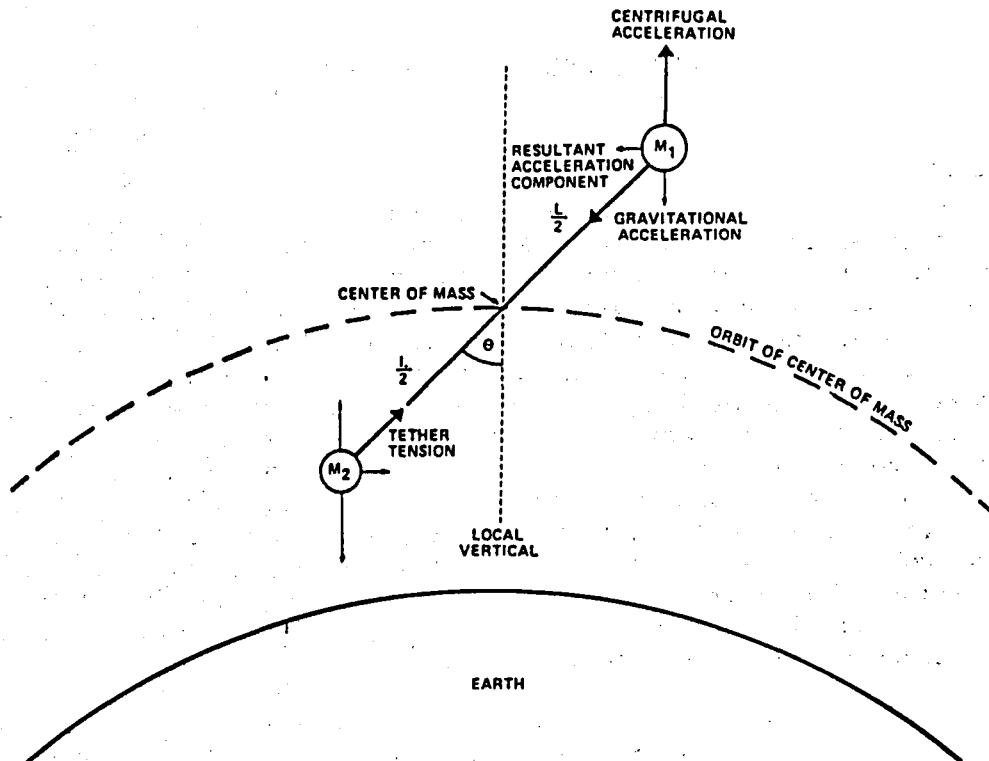

Figure 1. Stabilizing Forces Acting on Tethered Masses

The center of mass, halfway between equal masses, is in free fall, but the end masses are not. The top mass travels too fast for its altitude, thus giving rise to the excess centrifugal acceleration felt as tension in the tether, with the inverse occurring in the lower mass. The masses experience this tension as artificial gravity. Figure 2 shows its magnitude--far weaker, of course, than the forces on the surface of the Earth. As an example, the entire Shuttle could be suspended from a 25-km tether and generate a tension of only 10,000 newtons (2000 lb, or 1% of the Earth "weight" of the vehicle). That can be supported by a Kevlar line less than 1 cm in diameter. Likewise, a 500-kg mass suspended 100 km below the center of mass has a tether tension of only about 200 newtons (40 lb). Spacelab tethered at 10 km or a Shuttle External Tank at 1.0 km experiences approximately the same tension. The load requires only a 2-mm-diameter tether.

The mass of long tethers must be taken into account because the portion of the tether at the CG must support the tether as well as the payload. Thus, long tethers should be tapered for minimum mass.

The tether system is stable with either of two unequal masses "above" or "below" the center of mass. Due to the absence of damping, a dumbbell becomes a pendulum that oscillates or librates, about the line between it and the center of the Earth. Since both the displacement and restoring forces grow linearly with pendulum length, however, the libration periods for such gravity-gradient pendulums are independent of tether length. A flexible tether will thus swing solidly, rather than with the tether leading the tip masses, as with the chain of a child's swing. In-plane libration periods are very long and also independent of amplitude, being 0.577 orbit, while transverse librations have a period of 0.5 orbit.

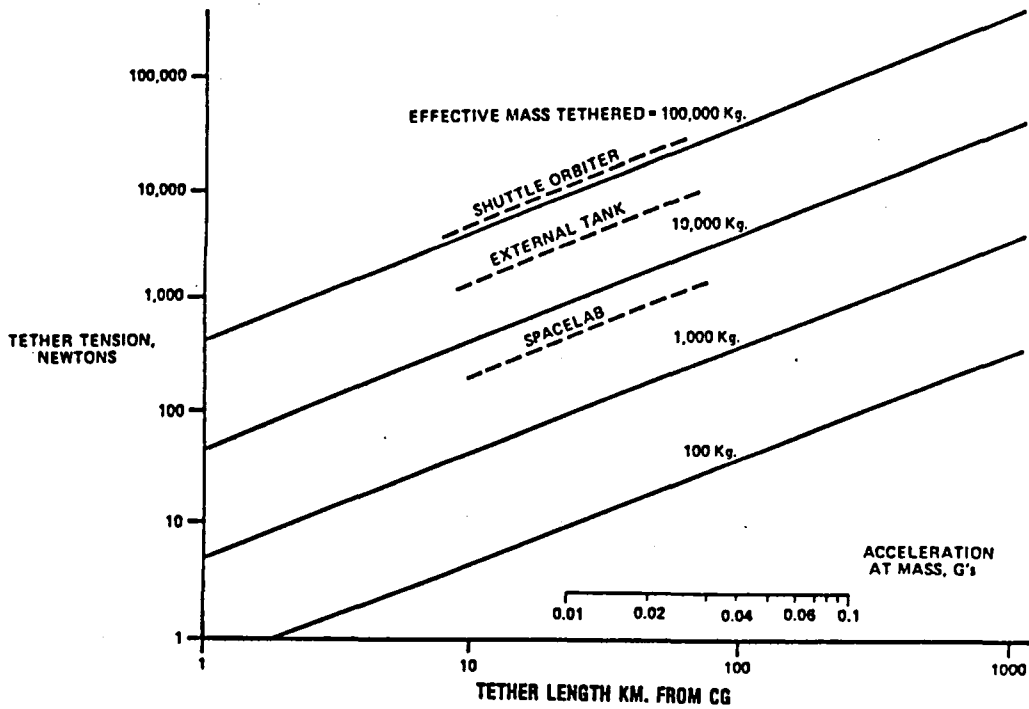

Figure 2. "Artificial Gravity" at Tethered Masses

The forces which cause a tethered system to librate are weak but persistent, and include the effects of Earth's oblateness and differential atmospheric drag due to solar heating. This libration can be damped out by varying tether length according to the following general rule: deploy tether when tension is more than usual and wind it in when tension is less than usual. This "yoyo" stationkeeping process pulls energy out of the system and can damp moderate in-plane and transverse librations simultaneously since they have different periods. The same goes for any shorter-period, higher-order tether vibrations.

A tethered satellite can be started into deployment by placing it a short distance from the system with an extendable boom, or giving it an initial velocity along the local vertical. For downward deployment this causes the satellite trajectory to move ahead of and down from the system, toward the Earth. As the satellite moves away from the deployer, the tether runs from the reel. The reel drive-motor operates as a brake. It produces tension in the tether, causing the satellite to move farther downward, as indicated in Fig. 3.

A slow deployment is nearly vertical; a fast one causes a large libration. The deployment action in effect transfers momentum and energy from the deployer to the satellite mass, with the system center of mass remaining at the initial orbit. By alternately reeling in and out, librations can be excited and even cause spinning of the system. These effects can be manipulated in practical system applications.

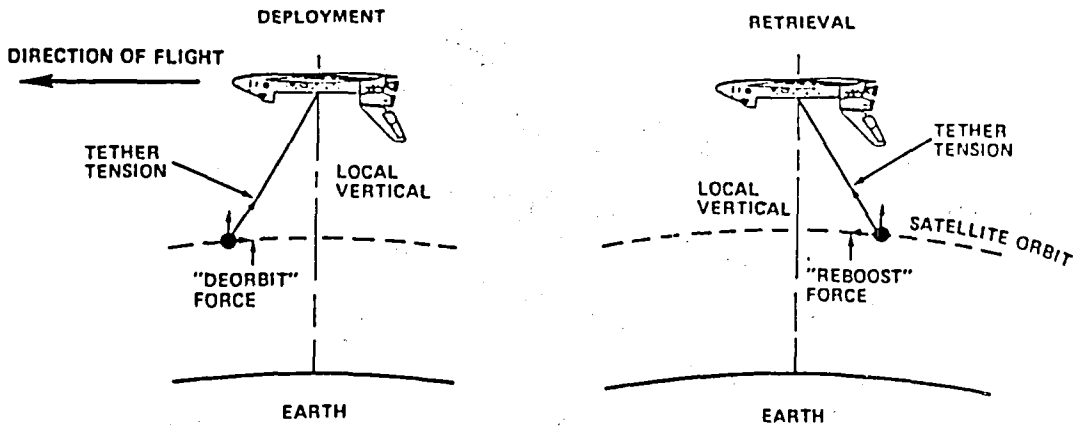

Figure 3. Deployment and Retrieval of a Tethered Satellite

Tethered Satellite System

A practical design of a tethered satellite system deployed from the Shuttle has evolved from nine years of study and advanced development by NASA, SAO, and the two industry contractors--Martin Marietta and Ball Aerospace. Figure 4 shows system design. It will flight-test the tether deployment and control on the Shuttle, plus perform useful scientific measurements in the bargain.

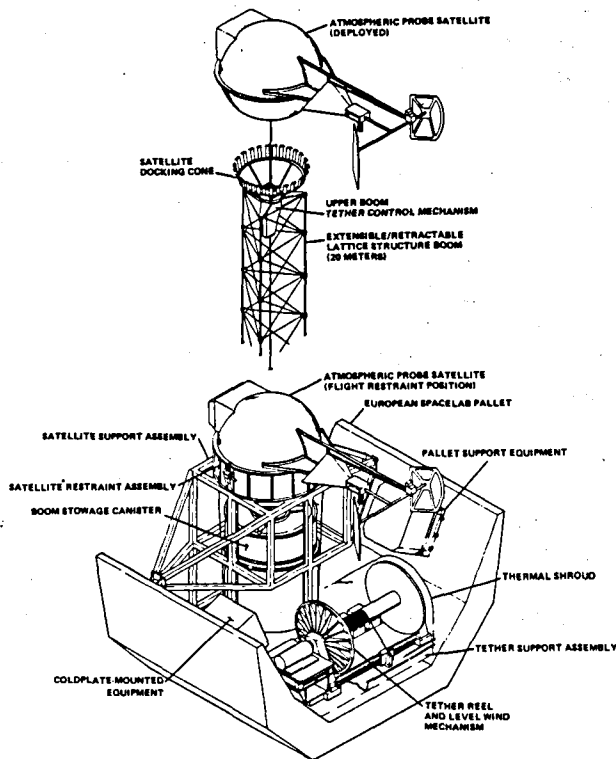

Figure 4. Typical Deployment and Control Mechanism

The satellite body takes the form of a sphere, aerodynamically stabilized and fitted with a dockline adapter that mates with a capture mechanism at the tip of an extendable boom. The tether is a very flexible metallic or synthetic line 1-2 mm in diameter and 100 km or more in length. The 20-m boom assists the satellite's deployment by displacing it from the Orbiter and also helps capture the satellite during retrieval.

The heart of the system design is the mechanism containing the tether reel and servo-drive motor and the tether tension, length, and rate sensors. A computer uses the sensor information and a closed-loop control algorithm to calculate drive commands for the reel motor. The crew operates the system from a control and display panel at the Orbiter aft flight deck.

The advanced development, flight program, and flight test of this system conjoins the government of Italy and NASA in a cooperative program. Italy will build and integrate the satellite. The U.S. will build the deployer and integrate the system with the Shuttle. Martin Marietta and Aeritalia have been selected as contractors. First flight has been scheduled for 1987. This system will pave the way for some intriguing applications, a number of which will be described in the following.

Applications

Atmospheric Uses: Tethered-vehicle access to altitudes as low as 100-150 km from the Shuttle would permit direct long-term observation of phenomena in the lower thermosphere and determination of its composition, observation of crustal geomagnetic phenomena, ability to control chemical-release experiences, and measurement of other dynamic physical processes which affect the atmosphere, ionosphere, and magnetosphere. The satellite for such measurements would be aerodynamically stabilized. Current designs can survive the temperatures of operating at least as low as 120-km altitude in steady state, and they can probably go even lower.

Towing an aerodynamic model from a space platform would give long-term access to such altitudes. Properly instrumented, such a model would represent a space-based "wind tunnel" experiencing Knudsen numbers not achievable in ground-based facilities. Heat shields, hypersonic vehicle designs, and aerobrakes for OTVs can be tested.

Electrodynamic Uses: Interactions between an insulated conducting wire tether and the Earth's magnetic field and plasma permits a more startling set of applications. In low-inclination orbits, a gravity-gradient-stabilized tether will become an electric generator by virtue of moving at high speed through the magnetic field. If electrons are collected by a metallized film balloon at the upper end and ejected at the lower end by an electron gun, a current will flow downward through the wire (see Fig. 5). This current will close by spiralling along the magnetic field lines intersecting the top and bottom ends of the wire and by flowing through the lower ionosphere at the ends of the lines. Tapping successive such plasma tubes the tether will generate a voltage of 200 V/km of length in low orbit. The current flows through different sections of the ionosphere as the wire tether moves in its orbit. The resultant

electric current can be passed through a payload connected between the lower end of the wire and the electron gun, and supply surprisingly large powers, as shown in Fig. 6.

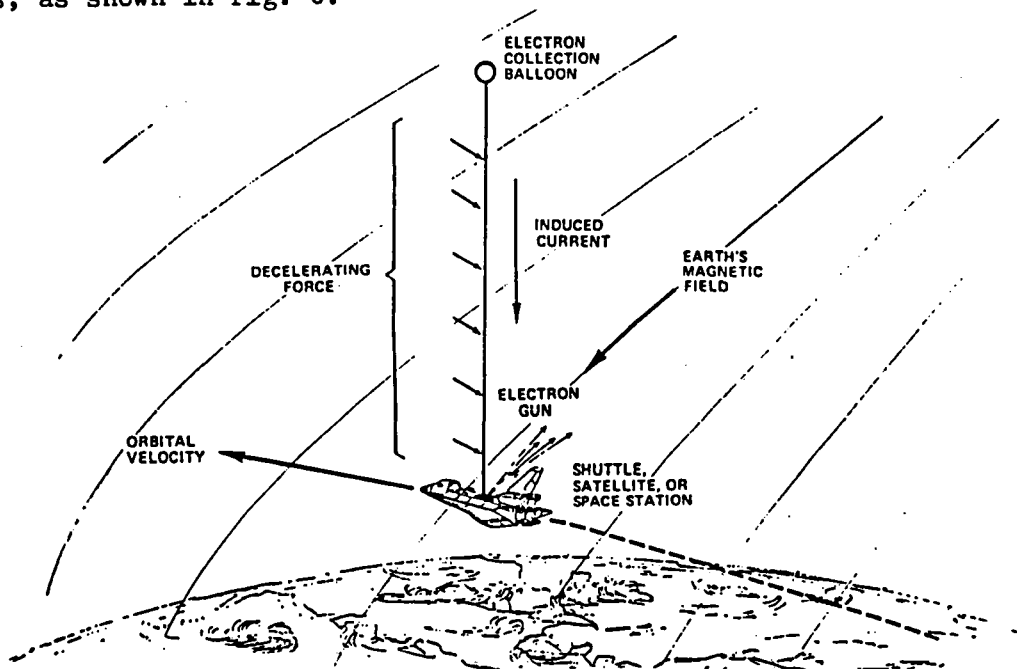

Figure 5. Tether As a Generator of High Power

	TETHER LENGTH		
	20km	50km	100km
CURRENT	3a	5a	5a
VOLTAGE	3.2kv	7.4kv	14.7kv
NET POWER TO PAYLOAD	8kw	33kw	70kw
ELECTRODYNAMIC DECELERATING FORCE	0.3 lb	1 lb	1.8 lb
TIME FOR ORBITER ALTITUDE DECREASE = 20nm	21 DAYS	7 DAYS	4 DAYS

Figure 6. Electrodynamic Power

The magnitude of the power depends on tether length, and is adjustable by controlling the electron gun's current. Thus 10-100 kW of power could be readily produced by a system much simpler and less expensive than solar arrays for such power. Not surprisingly, a price is paid; for the system extracts energy from its kinetic energy of motion through a small force that reduces system energy directly, at efficiency in the order of 70%.

In practice, altitude loss can be made up by continuous or periodic propulsive maneuvers, thus converting chemical energy to electrical at high efficiency by a rocket engine. Alternatively, the system could

provide high high peak powers for short times if altitude loss, such as shown in the table, is tolerable. Thus, the system could function as an emergency power generator for a space station should the primary system fail, and supplying, say, 8 kW at the expense of a loss of about 1 mi. per day. Similarly, this effect could force reentry of the Shuttle or other satellite outfitted with a tether should its retrorocket fail.

Such an electrodynamic tether could be reversed by driving a solar-array-produced current upward through the wire and placing the electron gun at the top instead of a balloon. The resulting electromotive force would increase the system altitude without expending propellants. This effect could be used for drag makeup for a space station or free-flying satellite. Additionally, in conjunction with its power-generated form it could supply peak power without propellants by reversing the current periodically and reboosting the system. For short-duty-cycle power, the solar arrays required for the reboost could be smaller than the power delivered by a factor equal to the duty cycle. For example, 100 kW can be produced for 10% of the time by a 10-kW solar array. Or the system could be used to eliminate batteries in solar array power systems.

The currents flowing through the wire of such a tether can stabilize satellites by properly timing their magnitude and direction. Thus electrodynamic tethers can provide power, increase or decrease altitude, provide for emergency deboost, decrease the size of solar arrays required, and provide for stability augmentation. In addition, cycling between use as a motor and generator at the right times can be used to circularize eccentric orbits or increase orbit eccentricity at will, without use of propellants.

In yet another potentially far-reaching effect, a wire tether can generate and launch extremely low frequency radio waves efficiently, by turning the electron gun on and off at the desired frequency, thus using the tether as an antenna. Waves can also be launched by a loop antenna composed of the tether, the magnetic lines of force, and the ionosphere. Since these waves leak through the lower ionosphere and then spread over most of the Earth by ducting, instant worldwide communications could be possible by simple self-powered tethered-wire "transmitters" of very high power.

Artificial Gravity Uses: All portions of a mass at the end of a tether experience a force equal to the tether tension. This force is perceived as artificial gravity. For a system stable along the local vertical it appears to be obtained without rotation since the entire system remains Earth-pointing. (In reality, it rotates about its own center of mass once per orbit.) The level of gravity obtainable is proportional to the length of the tether from the center of mass of the system and equals 4×10^{-4} g per km in low orbit. For space-station applications, this artificial gravity is free of floor-to-ceiling variations and the unpleasant coriolis effects present in small, rapidly rotating torus configurations (abandoned 20 years ago in favor of zero-g designs).

With tethers, consequently, the question of desirable g-level for a space station can be reopened, since a tether can be used to attain pure gravity simply by extending a counterweight along the gravity gradient. This mass could be passive, such as a piece of concrete, aggregated dead satellites, or Shuttle External Tanks; or it could consist of elements of the space station itself. The mass of the tether becomes a significant part of the station mass to attain 0.1 g (with 450 km of tapered tether), but is relatively minor for 0.05 g or less (Fig. 7). In fact, a full 1-g station is attainable with tethers made of known materials, but the tether mass would be considerably larger than that of the station itself. In all cases, the tether provides two-axis stabilization as well. An alternative would be to shorten the tether and induce a slow spin. This would make high g's possible, yet still avoid the bulk of the previous problems.

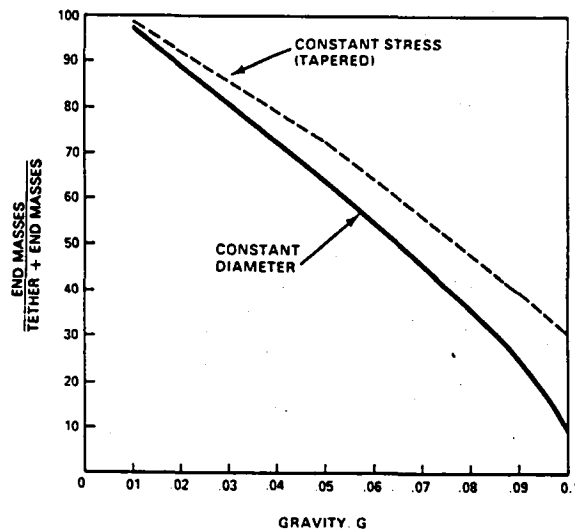

Figure 7. Mass of Tether Grows with Desired Gravity Level

The availability of 0.01-0.1 g in a station might allow less complex and more reliable crew-support systems (eating aids, showers, and toilets), more operational advantages (lack of floating objects, tools that stay where placed, and panels and controls operable the way used for training on the ground), and perhaps some long-term biological advantages. But these may be outweighed by such disadvantages as tether-system mass, complexity, and insuring survival after meteorite or debris impact. A zero-g space station obviously should be carefully compared to a tethered one in trade studies before a development decision.

Even if the space station proper employed zero g, a fractional-g facility, such as a life-sciences laboratory, could readily be tethered to it, with variable g attainable for a long time simply by adjusting tether length. Much shorter tethers could be used to hold safely and away from the station a platform having liquid propellants and other toxic or dangerous materials. Further, the artificial gravity at such a platform would greatly simplify the problem of propellant acquisition, storage, and transfer, making it ideal for OTV refueling with propellants transferred from the Orbiter (Fig. 8).

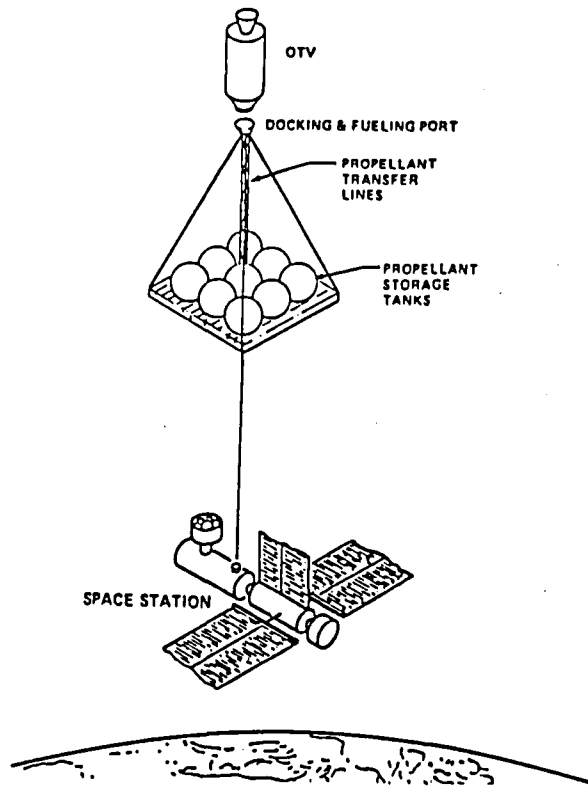

Figure 8. Cryogenic Propellant Storage and Transfer Platform

Figure 9 depicts a grander application, a wholly passive stable platform created by tethering two rows of empty Shuttle External Tanks or similar masses 10-20 km apart. The resulting milli-g level could be used for "parking" the Orbiter and for other platform functions of permanent facilities. Payloads brought to the lower level could be taken to the upper level without expending energy by coupling two movable transfer platforms together by tethers, of course, so that one moves toward the zero-g point as the other moves away from it.

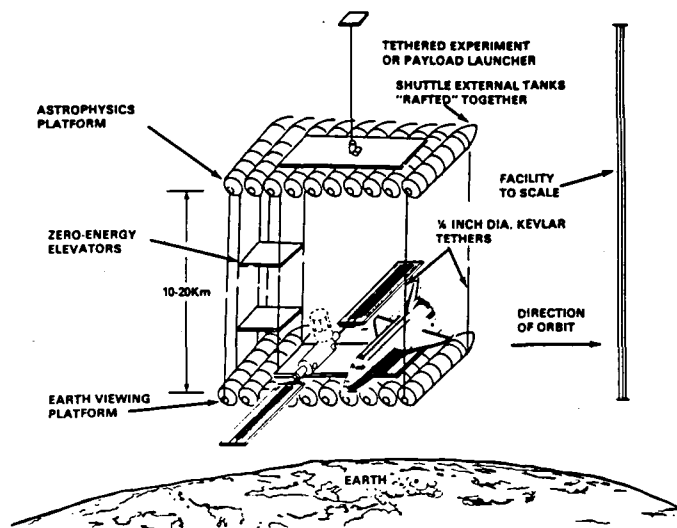

Figure 9. Passive Space Facility

Other potential high-payoff applications include a remote docking port for a space station to circumvent the danger of catastrophic collisions by incoming OTVs, satellites, or even the Shuttle. After docking at a safe distance, the vehicle would simply be reeled in slowly. Such a docking port could be passive, or it could contain a small tele-operated maneuvering vehicle allowing the incoming OTV to go passive. Tethers can also be used to store logistic aids around a space station.

Constellations: Constellations of space objects can be devised using tethers to tie them together and constrain their relative motions. This has broad application, but particularly so to the current conception of a space station as a base for servicing and tending a number of unmanned platforms co-orbiting with it. In the conventional solution, the platforms are placed in orbits with slightly differing elements so that each platform describes a trajectory "around" the station, coming near it periodically for rendezvous and docking. Although feasible, this scheme requires each platform to have separate utilities and complex operations. Instead, tethers could tie the platforms to the station, make them readily accessible, and supply power to them. Multiple platforms could be tethered like "beads on a string" along the local vertical, and such constellations have been analyzed and found to be stable, but they have poor access to the platforms.

Paired platforms represent a better solution. Dual reels would tether the platforms simultaneously toward and away from the Earth along the local vertical. Two-conductor tethers would allow powering the platforms from the central section. Deploying or retrieving the platforms simultaneously would avoid large shifts in the orbit of the central device. Such elements can be arrayed to form a two-dimensionally stable constellation, as indicated in Fig. 10, by placing them so that their central units (and center of mass) are in the same orbit plane and altitude, displaced along the velocity vector. Only slow relative motions would be induced by drag variations, solar pressure, etc. To keep them from drifting apart, or coming together, tethers connect them along the velocity vector and to a space station as well. Since tethers cannot support compressive loads, the entire system is lightly tensioned by insuring that the ballistic coefficient of each element is lower than that of the element leading it and higher than that of the element trailing it. In principle there is no limit to the number of platforms which can be so connected, powered and tended by a station.

Transportation Uses: In a tethered-mass system, the higher of two masses travels faster than the circular orbital velocity at its altitude, and the lower travels more slowly. The tether tension keeps the masses from flying apart. Suddenly disconnected, the upper mass will be in a Hohmann transfer to a higher apogee and the lower mass will be in a transfer to a lower perigee. That is, release from a tethered system can be used to change orbits without propulsion. Release can be from a tether stable along the local vertical ("hanging") or from intentionally librating or spinning masses, which yield larger separations between the masses. Separation half an orbit after release will be 7 times the tether length for a hanging release, up to 14 times with a

librating release, and greater than 25 times with a spinning release. this can greatly expand the sphere of access of the Shuttle or space station without propulsion in the payload and without any orbit-transfer rocket. Of course, shorter tethers could be used in conjunction with propelled transfer vehicles to reduce required Delta-V, to increase their payload, or both.

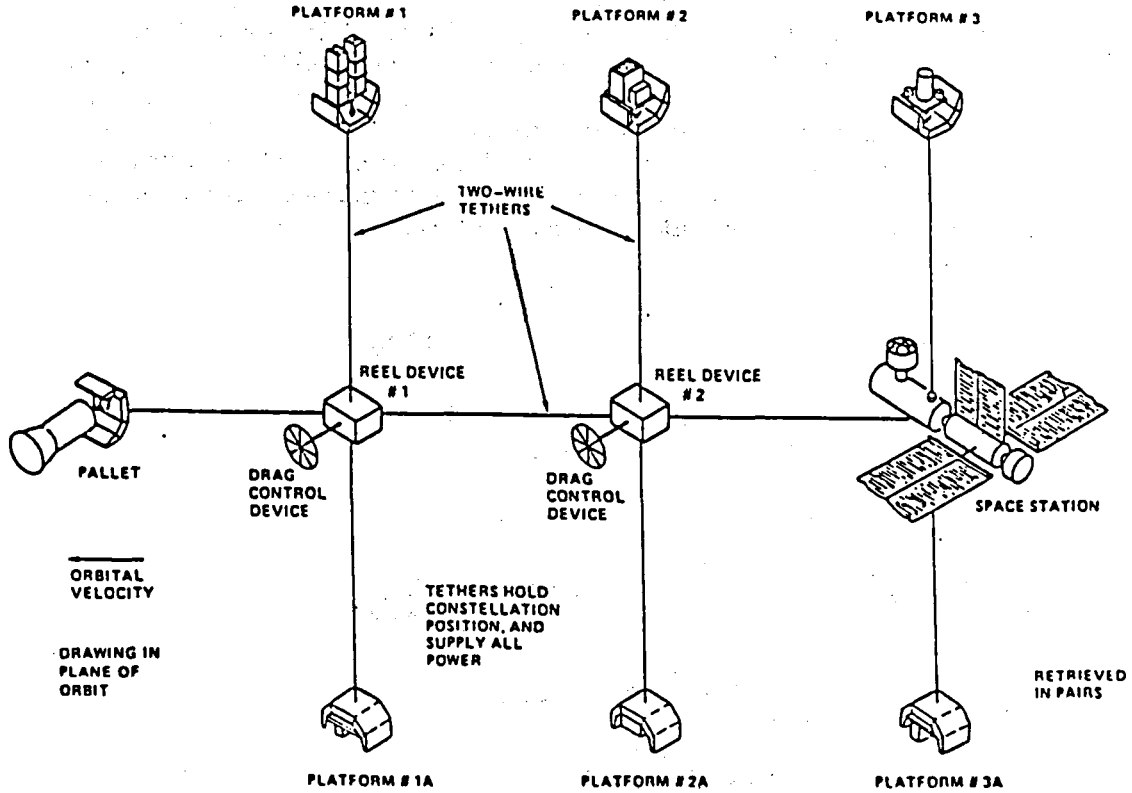

Figure 10. Two-Dimensional Tethered Constellation

A straightforward application would have the Shuttle External Tank (ET) delivered into orbit which increases the Shuttle payload by 1500 kg (since cryogenic rather than storable propellants would be used for direct ascent) and would also allow capture of excess propellants for transfer to permanent storage on a space station. The ET can be deorbited without any propellant-wasting burns by lowering it rapidly on a 25-km tether weighing about 100 kg, setting up a libration, and releasing it during a backswing. The ET can thus be made to deorbit precisely, transforming its momentum to the Orbiter and boosting it to a higher altitude. In a similar way, a Shuttle can rendezvous and dock with a space station, and when ready to go home, lower itself on a tether, thus raising the station orbit. With the contemplated frequency of Shuttle visits, the space station might not need any drag makeup propulsion. Further, the Shuttle would be able to lift 3000 kg more payload, not needing OMS propellants for a retroburn. Furthermore, the station orbit could be conveniently low for easy Shuttle access; that also increases Shuttle payload.

A variant of this concept envisions a space station supplied with electric power by an electrodynamic tether and periodically reboosted when resupply Shuttles depart.

A simple payload launcher would have payload plus transfer vehicle reeled out and then released in a hanging or swinging mode, simultaneously boosting the payload and reentering the Orbiter (Fig. 11). With a 260-km tether, this can add 40% to the LEO-GEO payload capability of a Centaur, IUS, or PAM. If the Shuttle is to avoid reentry from 400 km, the tether length must be limited to 100 km; that allows a 13% gain in payload. A similar system launched from a permanent launch facility would require energy to make up its altitude after a payload release. This energy can be imparted by departing Shuttles, by an electric propulsion system, or by the electrodynamic-motor effect using solar energy.

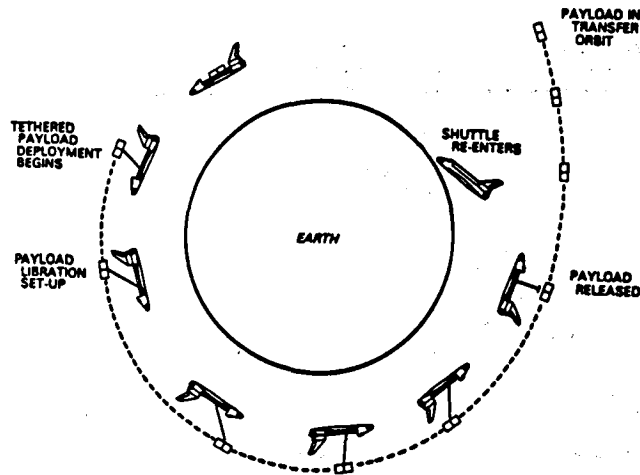

Figure 11. Payload Orbit is Raised and the Shuttle Deorbited

A permanent space base could consist of a spinning two-platform tether velocity-matched at the lower platform by a Shuttle at apogee. Payload transferred to this platform would be "transported" to the upper position by the tethered-platform's rotation and then released. Energy for the injection would come from a small reduction in the heavy-platform altitude; that energy would be made up by ion or electric-motor propulsion between launches. Although not necessitating use of a suborbital Shuttle, such a mode would increase Shuttle payload by 35% if the timing, docking, and safety problems can be solved. Payloads could be hurled most of the way to GEO using this scheme.

Another application of such tether launchers amounts to a piecemeal space elevator for transfer to GEO (Fig. 12). A payload released from a long tether on a LEO platform or Shuttle would transfer to a rendezvous with a longer tether deployed downward from a GEO platform. Upon hookup, which may require a small teleoperated maneuver package at the tether end to reduce guidance precision, the payload would climb up the wire. Ion

propulsion at the GEO end would supply the energy; and at the massive lower end energy could be supplied by any previously mentioned techniques. The system allows trading time for energy in the interest of mass.

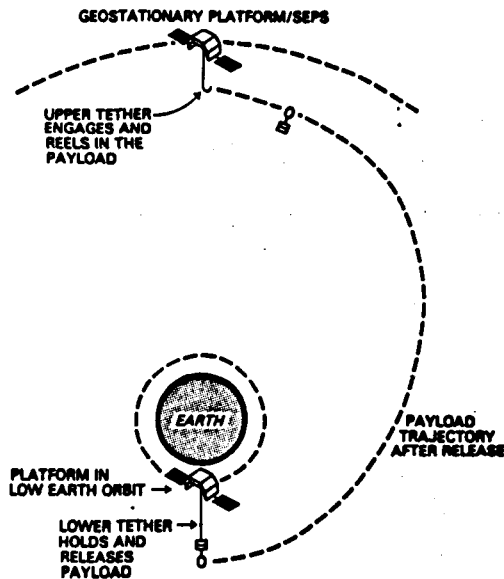

Figure 12. Two-Piece Tether "Elevator"

In principle, a completely propulsionless payload can be transferred impulsively from LEO to GEO with a very high (or infinite) I_{sp} by tethers constructed of known materials. Intuition fails us in sizing the necessary tethers: a 3300-km tether in GEO weighing 250 kg and with diameter of only 0.3 mm can suspend a 250 kg mass while developing a tension of only 20 n (4 lb). Thus the payload transfer could be achieved using a 1200-km tether in 400-km orbit and a 10,000-km tether at GEO (weighing the same as the shorter lower one due to the much weaker gravity field at GEO). Since the tether mass would be extremely large, a more practical solution would be to use shorter tethers and supply some Delta-V in the form of an OTV. As an example, a 430-km tether in LEO, a 5900-km tether in GEO, and a Centaur could transfer 2.8 times more payload than a Centaur alone--some 18,000 kg (40,000 lb). The combined tether mass would weigh 17 times the Centaur mass, or 340,000 kg, but this represents a reusable, permanent transfer resource showing a mass payback in seven flights.

The successful application of these concepts would depend on the development of navigation and operations techniques and their execution with precision. Such tether mediated transfers are very efficient and will probably play a significant role as transportation elements in a permanent space infrastructure.

SESSION II
TETHERED SATELLITE SYSTEM (TSS)

TETHERED SATELLITE SYSTEM
PROJECT OVERVIEW

Jay H. Laue

The use of tethers has really come a long way since 1974 when the use of the tether in conjunction with the shuttle was first proposed by Giuseppe Columbo to the AMPS working group. Just to give an idea of this progress, the concept as described by Columbo and others involved deployment of a large balloon downward from the shuttle using the atmospheric drag to further deploy it thereby giving a platform at the balloon to install scientific instruments. This concept was called Skyhook. This chart describes that concept.



The purpose of the Shuttle/Tethered Satellite System is to enable scientific investigations from the shuttle using a closed loop control system. This system has the capability for deployment toward or away from the earth, multiple round-trip missions, and deployment at distances up to 100 KM from the orbiter.



Shuttle/Tethered Satellite System

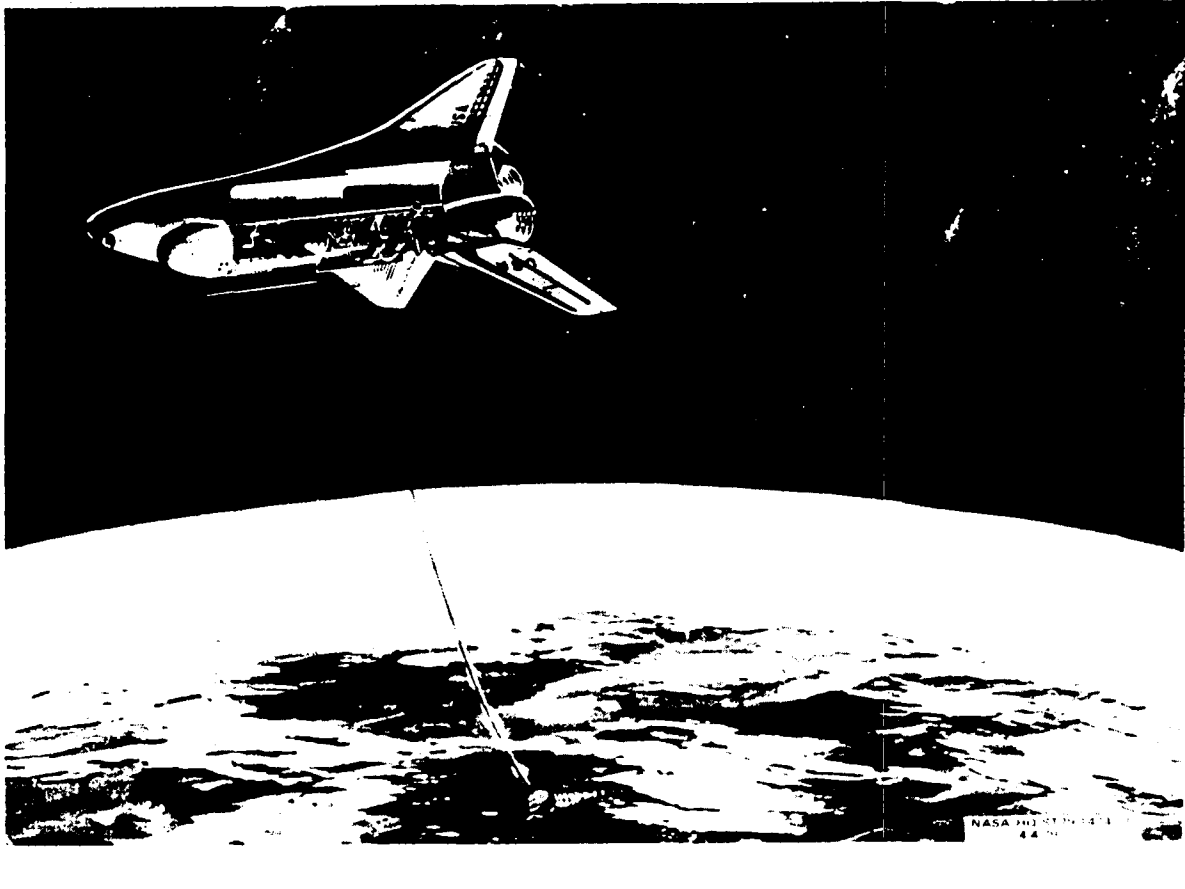

SHUTTLE/TETHERED SATELLITE SYSTEM

PURPOSE:

ENABLE A VARIETY OF SCIENTIFIC INVESTIGATIONS AND OPERATIONAL ACTIVITIES TO BE ACCOMPLISHED FROM THE SHUTTLE, CONSIDERING:

- USE A TETHERED SYSTEM WITH CLOSED-LOOP CONTROL
- DEPLOYMENT TOWARD OR AWAY FROM THE EARTH
- DEPLOYMENT UP TO 100 KM AWAY FROM THE ORBITER
- MULTIPLE ROUND TRIP MISSIONS

To give some perspective of the tethers length, consider the distance in Alabama from Huntsville to Florence. To put this in a local perspective, consider the distance in Virginia from Williamsburg to perhaps a little beyond Richmond or from Washington, D.C. to Hagerstown, Maryland. In Colorado it's about the distance from Denver to Colorado Springs. The message is that's a long, long string, 62 miles worth. That is what will be deployed for the first mission.



This chart indicates the satellite, the tether, and the deployer. For definition purposes, the deployer encompasses everything that is mounted on a pallet that shares a cargo bay with other payloads. The deployer includes an extendable boom, a reel for the tether, and the tether itself. The extendable boom for the shuttle tethered satellite system serves three purposes. It permits us to do the initial deployment and retrieval at a safe distance (at an arms length from the shuttle). It gives us the opportunity to align the force vector of the tether through the center of gravity of the shuttle. Finally, it gives some initial gravity gradient separation to aid in the deployment, and ultimately the retrieval of the tethered satellite.



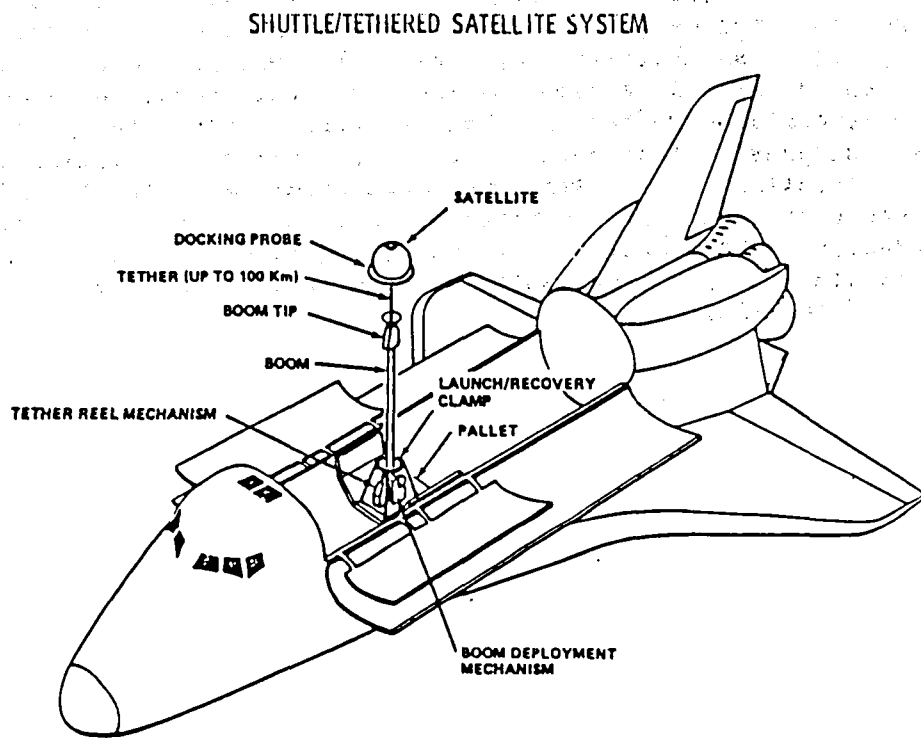
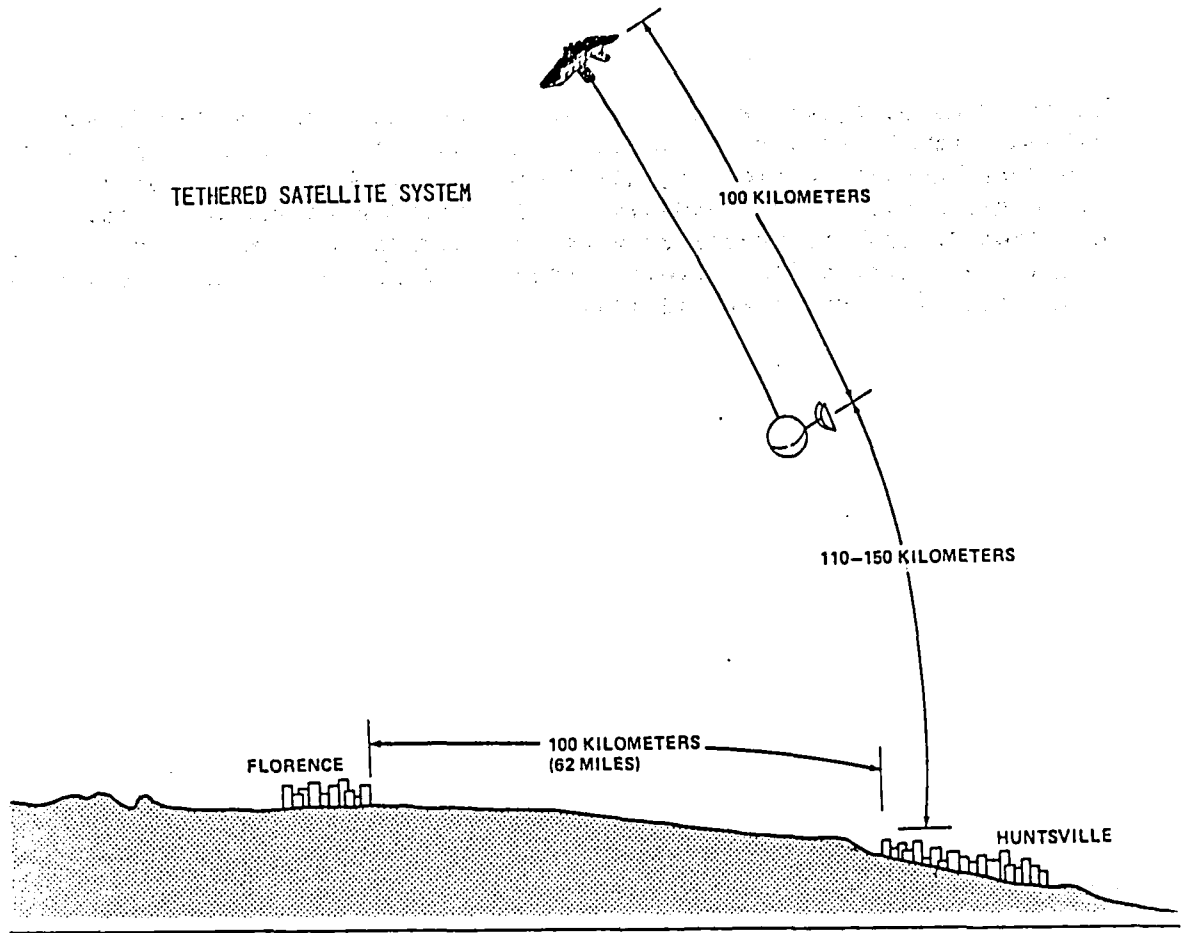

This chart summarizes Tethered Satellite System activities in terms of system studies, development of the tethered satellite system and science activities.



This chart points out the key guidelines of the Shuttle/Tethered Satellite System.



TETHERED SATELLITE SYSTEM

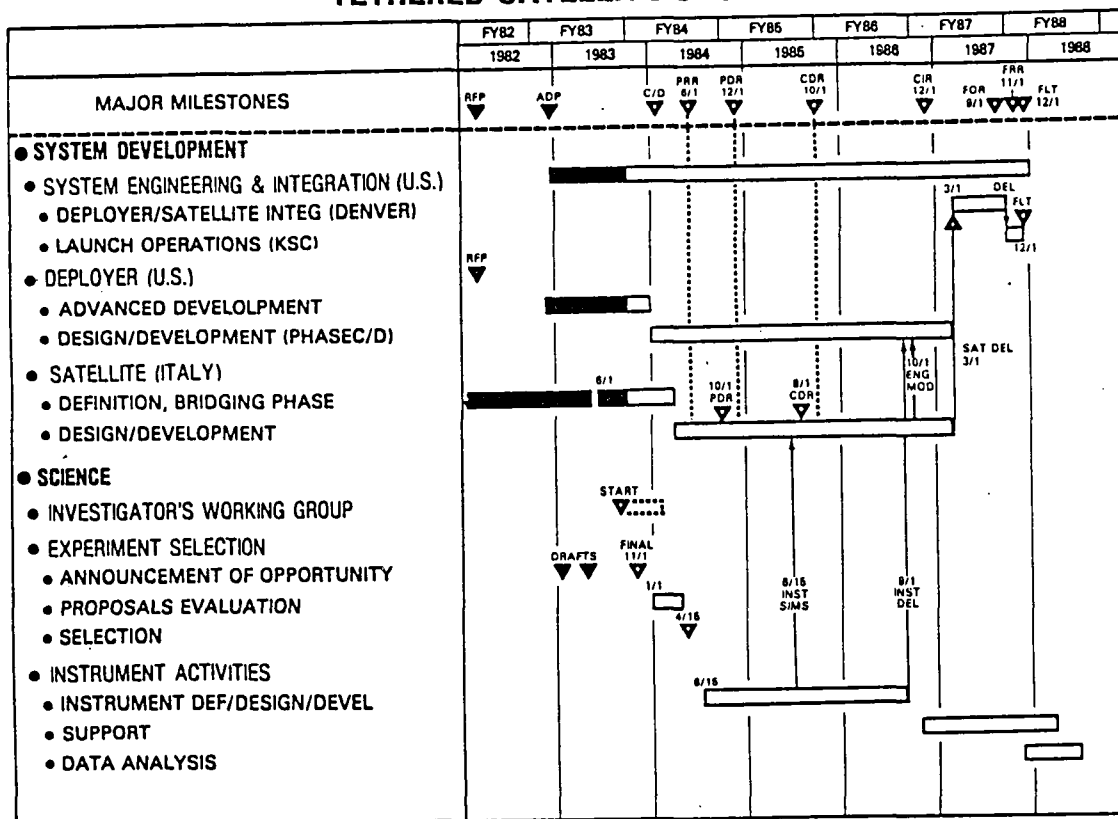

DELIVERY DATES ARE "ARRIVAL AT DESTINATION"

SHUTTLE-BORDED SATELLITE SYSTEM

KEY GUIDELINES

- 0 MISSION: ORBITER AT 230 KM, SATELLITE AT 130 KM.
36 HOURS VERIFICATION FLIGHT.
6.5-DAY MISSION CAPABILITY.
VERIFICATION FLIGHT IN 1987
- 0 SATELLITE MASS: UP TO 500 KG
- 0 SAFETY: JETTISON/RELEASE OF ALL DEPLOYED HARDWARE.
NO SINGLE POINT FAILURES ON CRITICAL HARDWARE.
- 0 LOW COST: PROTOFLIGHT APPROACH.
PROVEN CONCEPTS AND COMPONENTS.
- 0 POWER: PRIMARY POWER FROM ORBITER. TSS SECONDARY POWER.
- 0 CONTROL: FULL CONTROL OF ALL TSS SYSTEMS AND INSTRUMENTS FROM THE
ORBITER AFT FLIGHT DECK.
- 0 SATELLITE: ENGINEERING INSTRUMENTATION FOR SYSTEM VERIFICATION.
INFLUENCE DESIGN TO ACCOMMODATE AN ENGINEERING DEMONSTRATION
OF SCIENTIFIC COMPONENTS. FLEXIBILITY TO ACCOMMODATE POTENTIAL
USERS.

The responsibilities in the TSS progress are shown on this chart. The US will do the overall system and develop the deployer and Italy will develop the satellite. We will have a joint announcement of opportunity. Science instruments will be developed by both sides, European and non-European. The US will conduct launch operations supported by Italy.



This summarizes the user activities in the development of the TSS including the User Workshop in 1978 with the very important facility requirements definition team activity. It also includes the TSS peer review from July of 1980. The final meeting of the US/Italian Science Working Group has just been completed.



TIJHERED SATELLITE SYSTEM

RESPONSIBILITIES

UNITED STATES

ITALY

- o OVERALL SYSTEM:
 - REQUIREMENTS
 - INTEGRATION OF SATELLITE ONTO DEPLOYER
 - SYSTEM VERIFICATION
 - SYSTEM SOFTWARE
 - SYSTEM GSE
 - o DEPLOYER:
 - DEVELOPMENT
 - INTEGRATION OF INSTRUMENTS ONTO THE DEPLOYER
 - SOFTWARE
 - GSE
 - o ANNOUNCEMENT OF OPPORTUNITY (AO)
 - o SCIENCE INSTRUMENTS
 - DEVELOPMENT OF ALL NON-EUROPEAN INSTRUMENTS
 - o LAUNCH OPERATIONS
 - o MISSION OPERATIONS
 - o POST FLIGHT OPERATIONS
- o SATELLITE:
 - DEVELOPMENT
 - INTEGRATION OF INSTRUMENTS ONTO THE SATELLITE
 - SOFTWARE
 - GSE
 - o ANNOUNCEMENT OF OPPORTUNITY (AO)
 - o SCIENCE INSTRUMENTS:
 - DEVELOPMENT OF ALL EUROPEAN INSTRUMENTS
 - o LAUNCH OPERATIONS SUPPORT
 - o MISSION OPERATIONS SUPPORT
 - o POST FLIGHT OPERATIONS SUPPORT

TIJHERED SATELLITE SYSTEM

USER ACTIVITIES

- USER STUDIES (1976-1980)
 - SMITHSONIAN
 - UNIVERSITY OF CALIFORNIA, LOS ANGELES
 - UTAH STATE UNIVERSITY
- USERS WORKSHOP, NASA/UNIVERSITY OF ALABAMA HUNTSVILLE (MAY 1978)
- USERS WORKING GROUP (1977 - 1979)
 - OSTS - OSTA
 - OSS - OAST
 - MSFC - GSFC
 - DOD
- TSS FACILITY REQUIREMENTS DEFINITION TEAM (MAY 1979 - APRIL 1980)
- TSS PEER REVIEW (JULY 8-9, 1980)
- U.S./ITALIAN TSS SCIENCE WORKING GROUP (OCT. 1981 - PRESENT)

From the standpoint of science, I think it's generally recognized that the Tethered Satellite System offers a combination of capabilities that makes it quite unique. There is no other system that can give us all of these capabilities. It makes it very attractive for a number of scientific uses as well as the advanced applications. We have the capability to station keep at low altitude, the capability for upward or downward deployment, constant altitude flight, and conducting or non-conducting tethers. The satellite itself has the capability for carrying scientific packages. There are also the abilities to orient the satellite in its flight along with velocity vector and to measure its position in the command link from the satellite back to the orbiter.



The Science Working Group itself is a joint activity between the U.S. and Italy and is co-chaired by Dr. Hudson and Dr. Mariani, both of whom are here today with us. This group has had recent dialogue with TSS engineers providing technical advice, both the NASA and PSN, in the initial stages leading up to the issuance of the announcement of opportunity. This dialogue between the scientists and engineers will maximize the return from the TSS.



TETHERED SATELLITE SYSTEM

MAJOR SCIENCE AND APPLICATIONS ACCOMMODATION FEATURES

- LOW ALTITUDE STATION KEEPING CAPABILITY
- UPWARD OR DOWNWARD DEPLOYMENT
- CONSTANT ALTITUDE FLIGHT
- CONDUCTING OR NON-CONDUCTING TETHER
- EXCESS SATELLITE WEIGHT/VOLUME
- SATELLITE ORIENTATION CAPABILITY
- POSITION MEASUREMENT
- COMMAND LINK TO SATELLITE

TETHERED SATELLITE SYSTEM

U.S./ITALIAN SCIENCE WORKING GROUP (SWG):

PURPOSE

- PROVIDE SCIENTIFIC AND TECHNICAL ADVICE TO NASA AND PSN IN THE INITIAL STAGES OF ACTIVITY PRECEDING ISSUANCE OF JOINT ANNOUNCEMENT OF OPPORTUNITY (AO)
- ESTABLISH TWO-WAY DIALOGUE BETWEEN TSS SCIENTISTS AND ENGINEERS TO MAXIMIZE SCIENTIFIC RETURN FROM THE TSS

MEMBERSHIP

- NASA
 - DR. R. HUDSON, NASA/OSSA, CO-CHAIRMAN
 - DR. P. BANKS, STANFORD UNIVERSITY
 - DR. G. CARRIGAN, UNIVERSITY OF MICHIGAN
 - DR. P. COLEMAN, UNIVERSITY OF CALIFORNIA LOS ANGELES
 - DR. R. FREDRICKS, TRW CORPORATION
- ITALY, NATIONAL SPACE PLAN (PSN)
 - DR. F. MARIANI, UNIVERSITY OF ROME, PSN, CO-CHAIRMAN
 - DR. M. DOBROWOLNY, INSTITUTE FISICA SPAZIO INTERPLANETARIO, CNR, FRASCATI
 - DR. P. PELLEGRINI, INSTITUTE RICERCHE ONCLE ELETTROMAGNETICHE, CNR, FIRENZE
 - DR. S. VETRELLA, INSTITUTE AERODYNAMICA, UNIVERSITY OF NAPOLI

Based on all the user activities that have transpired to date, the plan for the first mission which will occur in April 87 will be an upward deployed electrodynamics mission. It will be primarily oriented to study field aligned currents, various wave modes and electrodynamic interactions with the tethered satellite. The second mission will be a downward deployed atmospheric flight which will study the dynamic properties and composition of the charge of neutral atmosphere, below 180 KM. It will also study accelerations due to atmospheric density variations in satellite temperatures.



This figure pictorially illustrates the first mission which will be upward deployed to a 20 KM distance. It will be a conducting electro-dynamics tether. The shuttle would be at the standard 160 NM orbit with the full 20 KM deployment upward.



SCIENCE OBJECTIVES
FOR THE TSS-1 AND TSS-2 VERIFICATION MISSIONS

● TSS-1 ELECTRODYNAMICS MISSION

TO CONDUCT ACTIVE EXPERIMENTS IN THE IONOSPHERIC PLASMA USING THE TSS TO STUDY THE GENERATION OF FIELD ALIGNED CURRENTS, THE GENERATION OF INSTABILITIES AND VARIOUS WAVE MODES, THE PLASMA - ELECTRODYNAMIC INTERACTIONS WITH THE TETHERED SATELLITE, ETC.

● TSS-2 ATMOSPHERIC AND SOLID EARTH PHYSICS MISSION

PRIMARY - TO MEASURE THE DYNAMIC PROPERTIES AND COMPOSITION OF THE CHARGED AND NEUTRAL ATMOSPHERE BELOW 180 KM.

SECONDARY - TO MEASURE THE SATELLITE ENVIRONMENT, INCLUDING SATELLITE ACCELERATIONS DUE TO ATMOSPHERIC DENSITY VARIATIONS, SATELLITE TEMPERATURE, ETC.

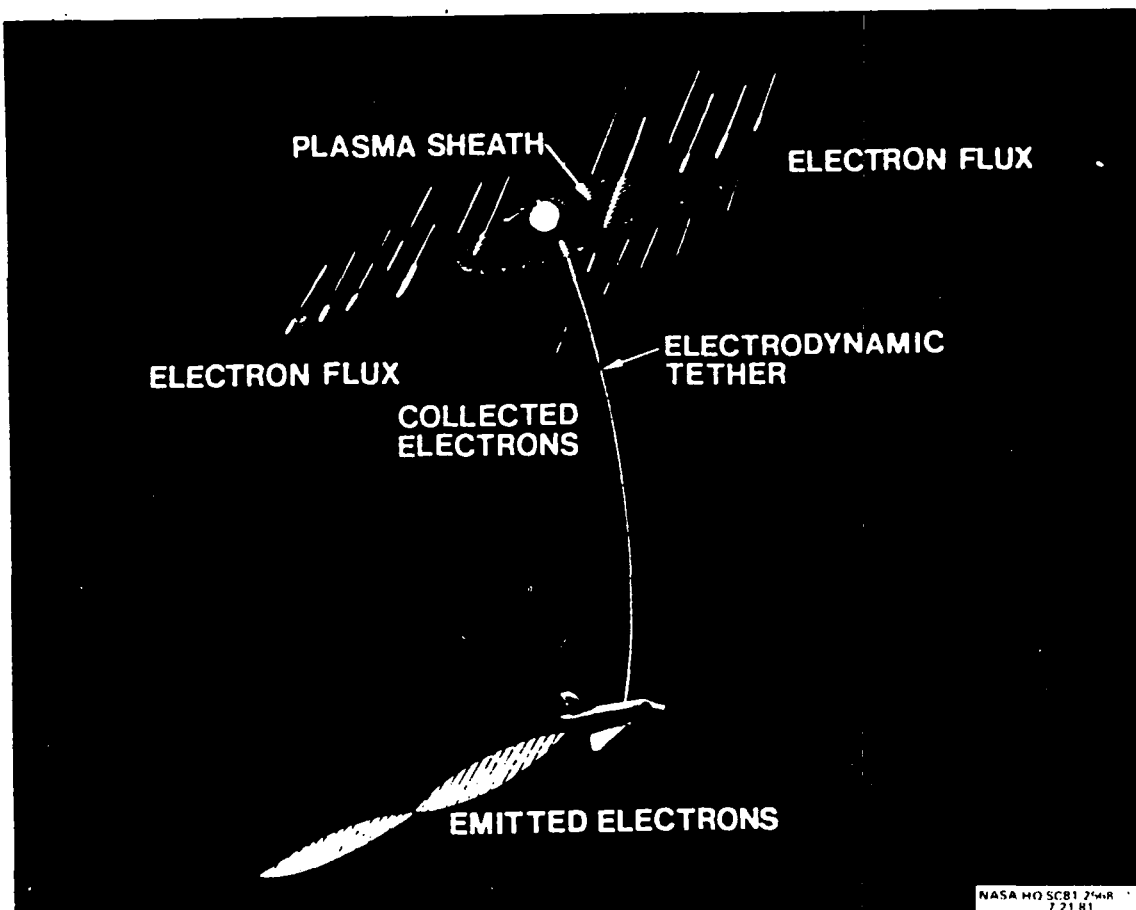

The second mission deploys to the full capacity of the reel mechanism, that is, down to 100 KM, with the orbiter in this case based at 230 KM. 100 KM deployment puts the satellite at an altitude of 130 KM. This is of considerable interest from the standpoint of atmospheric science and it provides a capability heretofore not realized.



In summary, the studies have established the feasibility of deployment and retrieval of the system. Preliminary designs and cost projections have been accomplished in phase B. Updated designs and the advanced development phase are currently being worked on. This two phase development approach is based on the expectation that it will be a cooperative endeavor between the U.S. and Italy. A Memorandum of Understanding is being finalized to that effect. Plans are being made for issuance of a joint announcement of opportunity this summer for the initial missions. These are planned for April 87 and a year later in April 88. It is expected that operational missions will follow from that.



TYPICAL SCIENCE TETHER APPLICATION

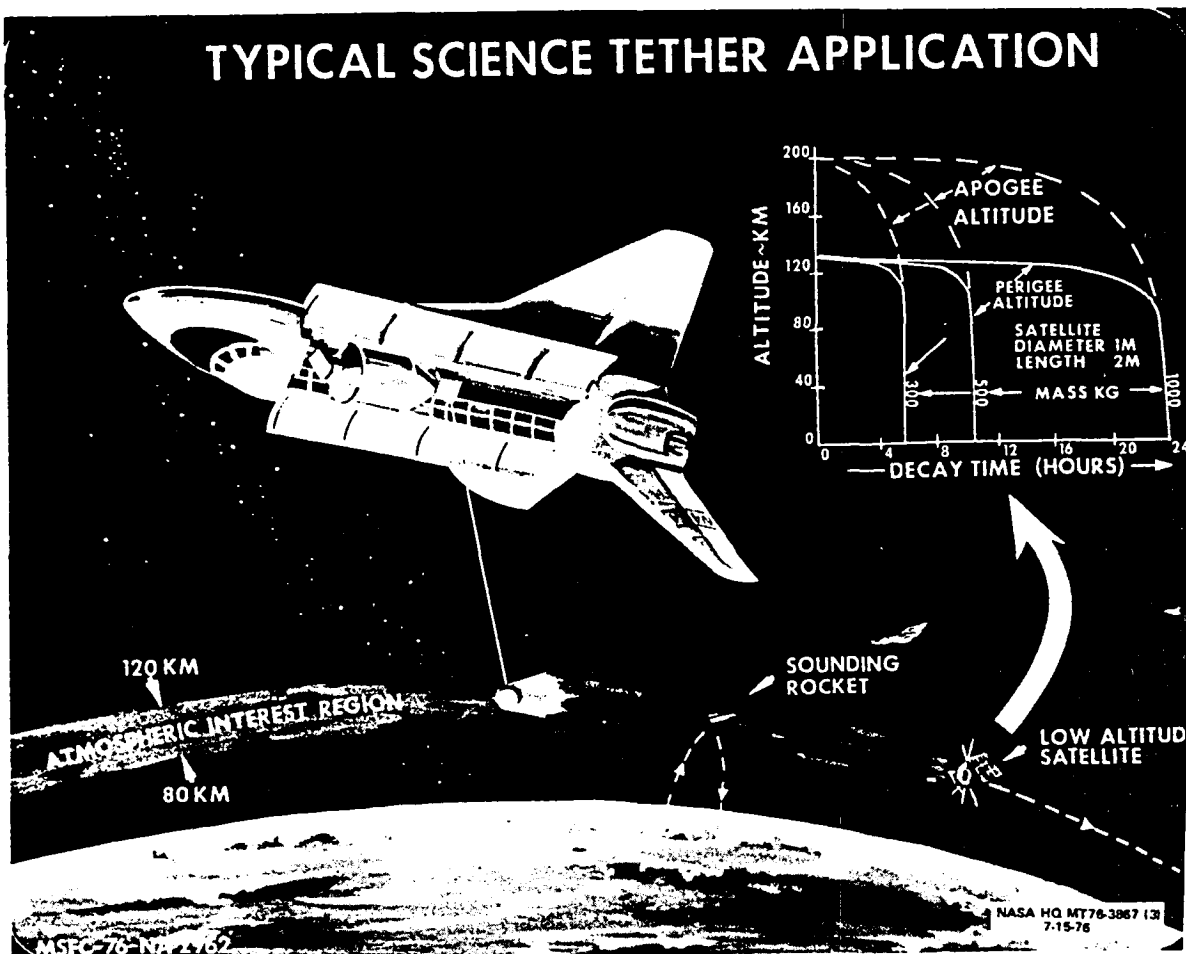

TETHERED SATELLITE SYSTEM

CURRENT STATUS

- PREVIOUS STUDIES HAVE ESTABLISHED FEASIBILITY OF DEPLOYMENT, STABILIZATION, AND RETRIEVAL OF A TETHERED SATELLITE.
- PHASE B DEFINITION STUDIES HAVE RESULTED IN PRELIMINARY DESIGNS AND COST PROJECTIONS.
- A TWO-PHASE TETHER SYSTEM DEVELOPMENT IS BEING IMPLEMENTED, BASED ON THE EXPECTATION THAT THE TETHERED SATELLITE SYSTEM WILL BE A COOPERATIVE U.S./ITALIAN PROGRAM.
- A JOINT U.S./ITALIAN ANNOUNCEMENT OF OPPORTUNITY (AO) WILL BE ISSUED THIS SUMMER FOR SCIENCE EXPERIMENTS TO BE FLOWN ON THE INITIAL MISSIONS.
- INITIAL MISSIONS ARE PLANNED FOR 1987 AND 1988. OPERATIONAL MISSIONS ARE EXPECTED TO FOLLOW.

So with that then as a kind of quick history and project overview, Don Crouch of Martin Marietta, our prime contractor for the development of the tethered system, will present an overview of the deployed development activity.

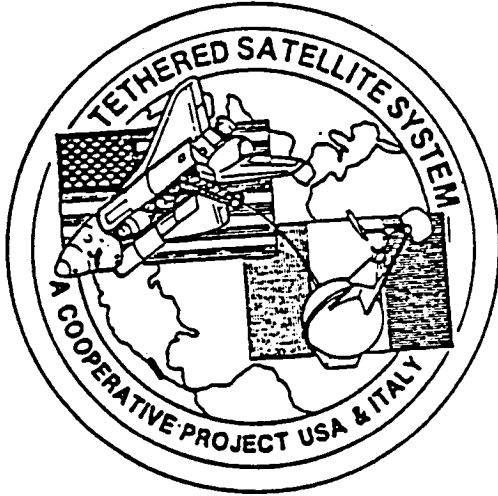

SHUTTLE TETHERED SATELLITE SYSTEM
PROGRAM OVERVIEW

Donald Crouch
Martin Marietta

Introduction

NASA and the Italian Council for National Research are currently performing the first phase of a two-phase program which will lead to demonstration flights of the Tethered Satellite System in 1987. The first phase of the program, being performed under a U.S.-Italian Letter of Agreement, consists of preliminary design, establishment of interfaces, and the development of critical engineering evaluation hardware. The second phase of the program, subject to the approval of both governments, will be performed under a new Memorandum of Understanding for the demonstration flights. This agreement designates NASA as being responsible for the overall system integration and interfacing hardware, launch operations, and mission operations. The Italian Council for National Research will provide the satellite for the first two demonstration flights.

President Reagan, in a recent letter to the President of Italy, has suggested the possibility of Italian and U.S. Payload Specialists being assigned to the first demonstration flight, currently designated as STS 52.

Martin Marietta-Denver Aerospace has been selected as the prime contractor to perform the U.S. portions of the project under the management of NASA's Marshall Space Flight Center. Aeritalia, located in Turin, Italy will develop the satellite for the two demonstration flights under the management of the Italian Council for National Research. Joint management of the project will be accomplished through a project Technical Plan operating within the guidelines of the U.S.-Italian Memorandum of Understanding.

Demonstration Flights

It is currently planned that demonstration of the tethered satellite system will consist of two scientific missions. The first mission, currently planned for April 1987, will include deployment of the satellite upward from the Orbiter 10-20 kilometers (6-12 miles) using an electrically conductive tether. It will allow understanding of tether electromagnetic interactions by in-situ generation and study of large hydromagnetic waves and magnetic field-aligned currents in the space plasma. The practicality of electric power generation using an electrically-conductive tether intersecting the earth's magnetic field will be demonstrated.

The second demonstration flight will follow the first by 6-12 months. This flight, with the satellite refurbished to an atmospheric probe configuration, will be deployed earthward a distance of 100 kilometers (62 miles) to an altitude of approximately 130 kilometers (80 miles) above the earth's surface. This probe, using an electrically non-conductive tether, will perform direct measurements of magnetospheric-ionospheric-atmospheric coupling processes in the lower thermosphere. Both missions will involve a deployed satellite operational time of approximately 36 hours.

A tethered satellite operational phase with frequent flights is expected to follow the two demonstration flights. Satellites can be designed to perform specific missions, and refurbished as required for follow-on flights at different altitudes and orbital inclinations.

Operational Overview

Tethered Satellite-to-Orbiter-to-Ground Interfaces

The Tethered Satellite System (TSS) is interfaced in the Orbiter for the two demonstration flights using a spacelab-type pallet as shown in Figure 1.

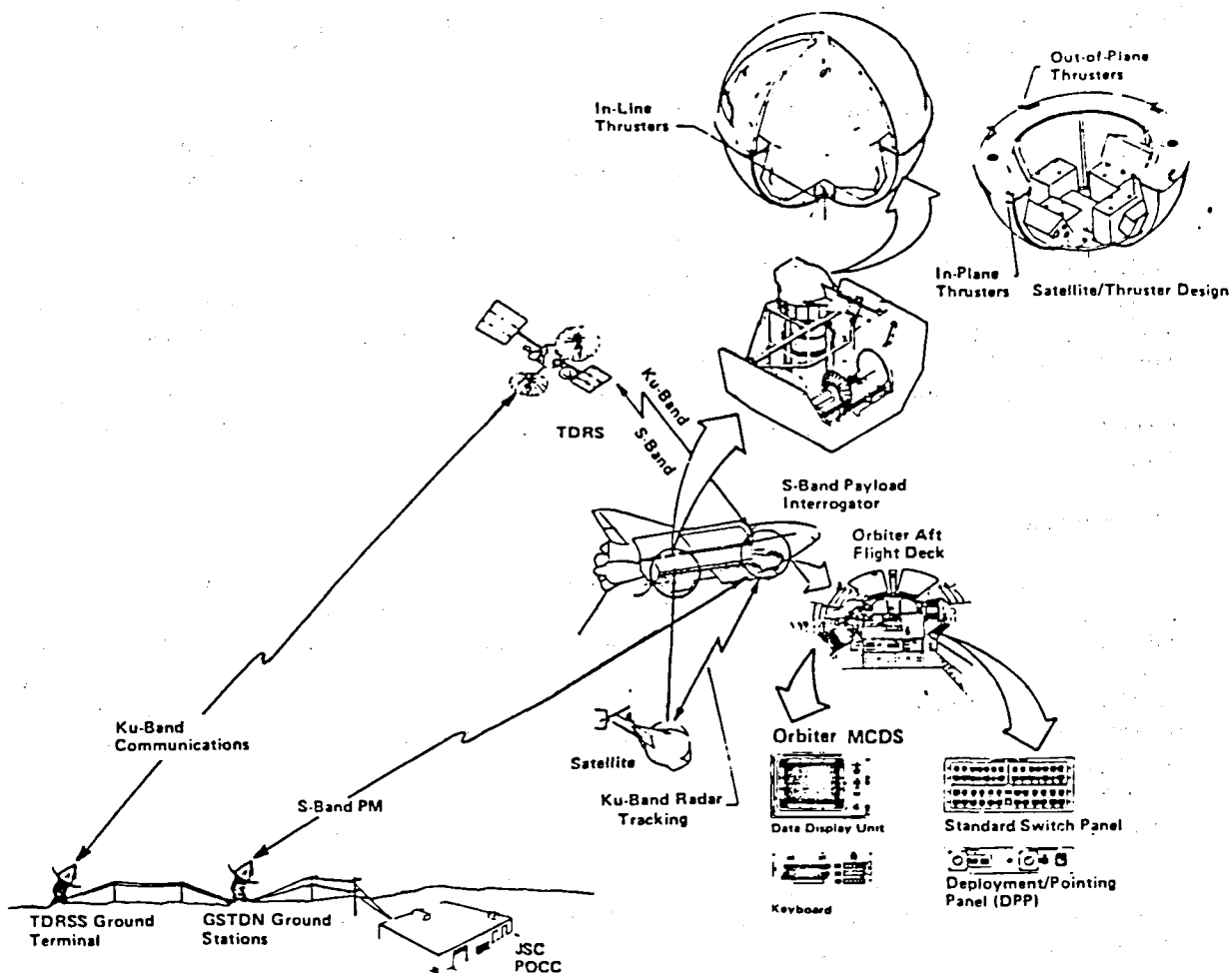

Figure 1. Design Overview - TSS/Orbiter/Ground Interfaces

Primary control of the TSS is accomplished by the Orbiter mission specialist or payload specialist operating from the Aft Flight Deck. The mission or payload specialist will use a combination of the Orbiter Multifunctional CRT Display System (MCDS), Standard Switch Panel, and Deployment Pointing Panel for controlling and monitoring the TSS. Overall automatic control sequences for both deployer and satellite are provided by a deployer-mounted, microprocessor-based computer.

Commands to the deployed satellite, and telemetry data from the satellite are accomplished using the Orbiter detached payload S-Band Payload Interrogator. Most commands for the tether control system and satellite thruster control system will originate in the TSS deployer computer. The Orbiter Ku-Band system, operating in the radar mode, is used for tracking the deployed satellite.

Both the satellite and deployer commands and telemetry are interleaved with the Orbiter data stream. Orbiter data is routed to the NASA Johnson Space Center (JSC) Payload Operations Control Center (POCC). The Orbiter data is transmitted via its Ku-Band and S-Band systems to the Tracking and Data Relay Satellite System (TDRSS), where it is retransmitted to the ground stations and on to the JSC POCC. Operational performance of the TSS is monitored at the POCC, and it will be possible to uplink commands (if required) to either the deployer or satellite. Scientific data are also monitored at the POCC, and it will be possible for the principal investigators to interact with their scientific instruments (satellite or deployer-mounted) throughout the mission.

TSS Deployment Concept

Satellites tethered to the Orbiter are inherently stable along the local vertical either directly below or above the Orbiter. In the case of the downward deployed satellite, the tether, which travels at the Orbiter angular velocity, forces the satellite to travel at the same angular velocity which is "suborbital" for the lower satellite altitude. Therefore, the downward earth gravitational pull on the satellite is greater than the centripetal force, and there is a net "gravity gradient" earthward force on the satellite which is reacted by the tether. The gravity gradient force reacted on the tether by a 500 kilogram (1100 pound) satellite deployed 100 kilometers (62 miles) is approximately 300 Newtons (65 pounds), depending upon the mass of the tether and operating accelerations.

The forces acting on an upward deployed satellite are similar to the downward case. The Orbiter-connected tether forces the upward deployed satellite to travel at a "superorbital" angular velocity. The resultant centripetal force exceeds the gravitational force producing a net "gravity gradient" reaction force in the tether. Satellites and tethers of equal mass produce the same gravity gradient force in the tether for equally deployed distances below or above the Orbiter.

Figure 2 illustrates the deployment concept for the TSS.

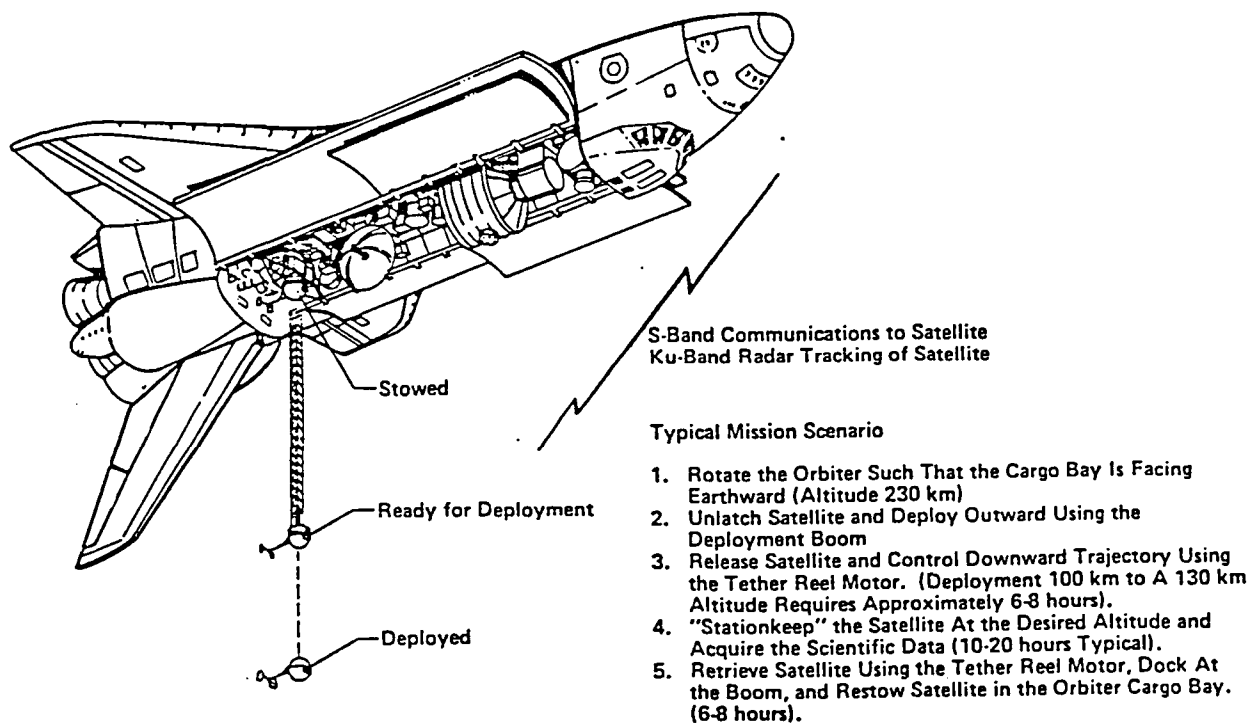

Figure 2. Design Overview - TSS Deployment Concept

The satellite is released from its restraining structure and translated downward (or upward) on a 12-meter boom. After final checkouts are completed, the satellite is released from the boom tip docking cone, and a combination of the gravity gradient force and small, tether-aligned thrusters (reference Figure 1) cause the satellite to begin deploying. The initial gravity gradient force acting on the satellite at a 12-meter separation distance is very small—approximately 0.01 Newtons (0.1 ounces). The tether aligned thrusters, operating at 1-2 Newtons (0.2 to 0.4 pounds), provide the additional force necessary to overcome tether friction in the upper boom tether control mechanisms. The natural gravity gradient forces in the tether rise with increasing separation distance, and the tether-aligned thrusters are turned-off when a value of approximately 2 Newtons is attained. This occurs at a separation distance of approximately 1 kilometer (0.6 miles).

Deployment of the satellite to a distance of 100 km requires 6-8 hours, depending upon the maximum separation velocity and angular deviation permitted during the descent. The TSS has been designed for a maximum velocity of approximately 80 km per hour (50 MPH). Figure 3 (deployment) illustrates typical deployment parameters including distance,

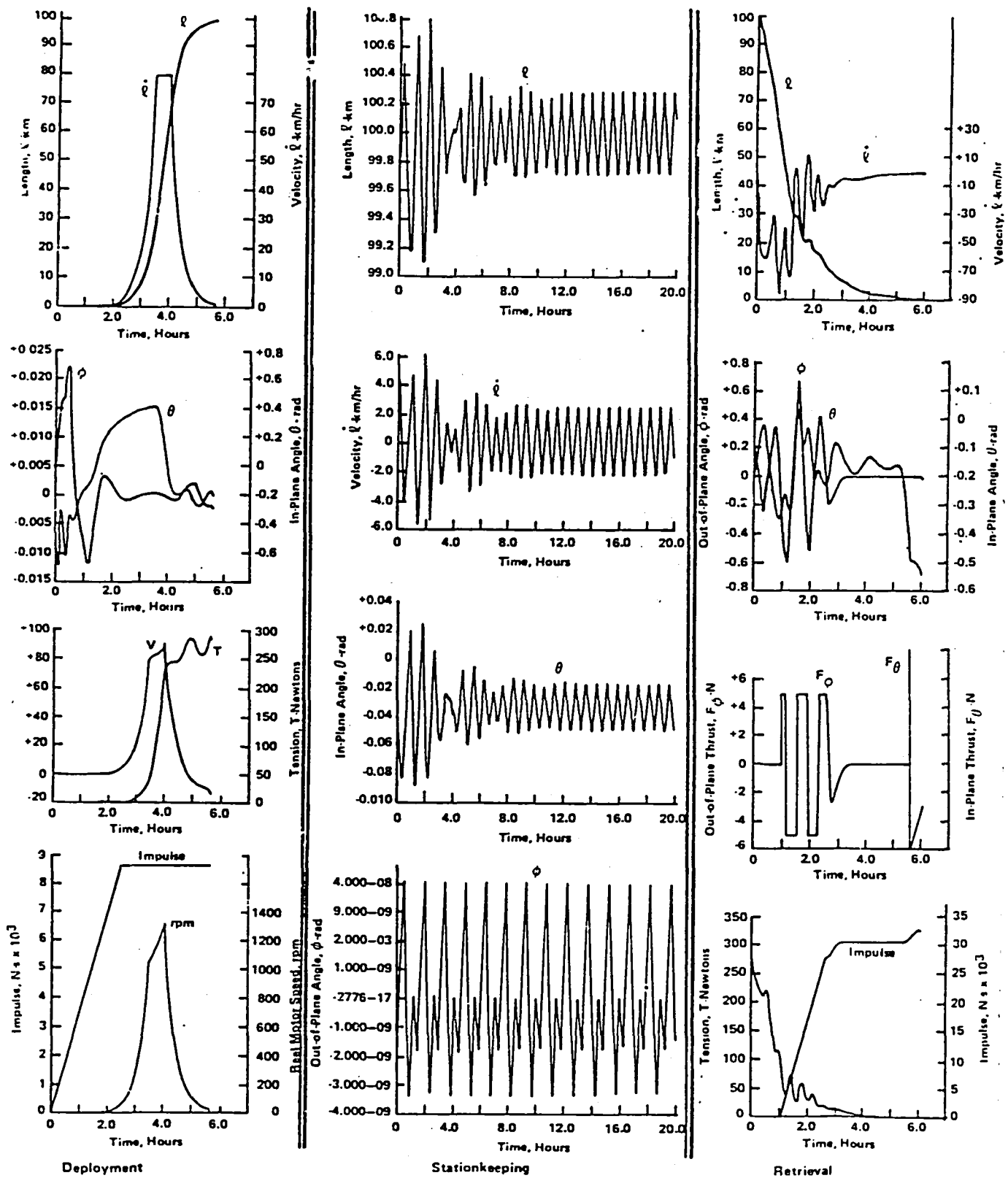

Figure 3. Typical Satellite Deployment, Stationkeeping, and Retrieval Profiles (130 km Deployment Altitude)

separation velocity, in and out-of-plane angles, tether reel applied voltage and rpm, and the tether-aligned thruster total impulse consumed as a function of time during deployment to a 130 km (80 mi) altitude.

Tether control is also required during "stationkeeping" at the deployed altitude, and particularly at the lower altitudes where atmospheric "wind forces" are significant. The 20-hour "stationkeeping" plots of Fig. 3 illustrate the effects of such a control whereby the tether is slowly retrieved and deployed approximately ± 300 m about the nominal 100 km deployed distance in order to damp the pendulous oscillations. The effects of the aerodynamic drag on the satellite can be seen as a 0.04 radian bias on the in-plane angle stationkeeping plot.

Retrieval of the satellite can best be performed using in-plane and out-of-plane satellite thrusters to dampen pendulous angles as they tend to build-up during the retrieval maneuver. The location of these small thrusters is shown in Fig. 1. Figure 3 (retrieval) illustrates a typical case whereby the logic is set to operate the in-plane and out-of-plane side thrusters when the pendulous tether angle exceeds 0.6 and 0.7 radians. The operation of both thrusters is illustrated, although the out-of-plane damping requirement predominates. As with the deployment case, the tether-aligned thrusters are operated during the last 1 km of separation distance prior to docking the satellite.

Control algorithms for operating both the tether control motors, and the satellite thrusters are stored in the deployer computer. These control algorithms, operating in conjunction with feedback data (range/range rate, angle/angle rate), compute the necessary control functions.

Design Overview

Tethered Satellite-to-Orbiter Interface

Figure 2 illustrated the major elements of the TSS which will be used for the demonstration flights including the satellite, satellite support assembly with deployment boom, tether support assembly, and cold plate-mounted equipment.

Figure 4 illustrates the pallet location at the most rearward position in the Orbiter although the system has been designed to operate at any pallet location within the cargo bay thus increasing the potential shared mission opportunities.

The satellite support structure is interfaced at two "sill" attachment hard points and at a lower pallet keel fitting. A satellite restraint structure is provided which interfaces to the satellite equatorial ring and the satellite is restrained by four motor-driven latches.

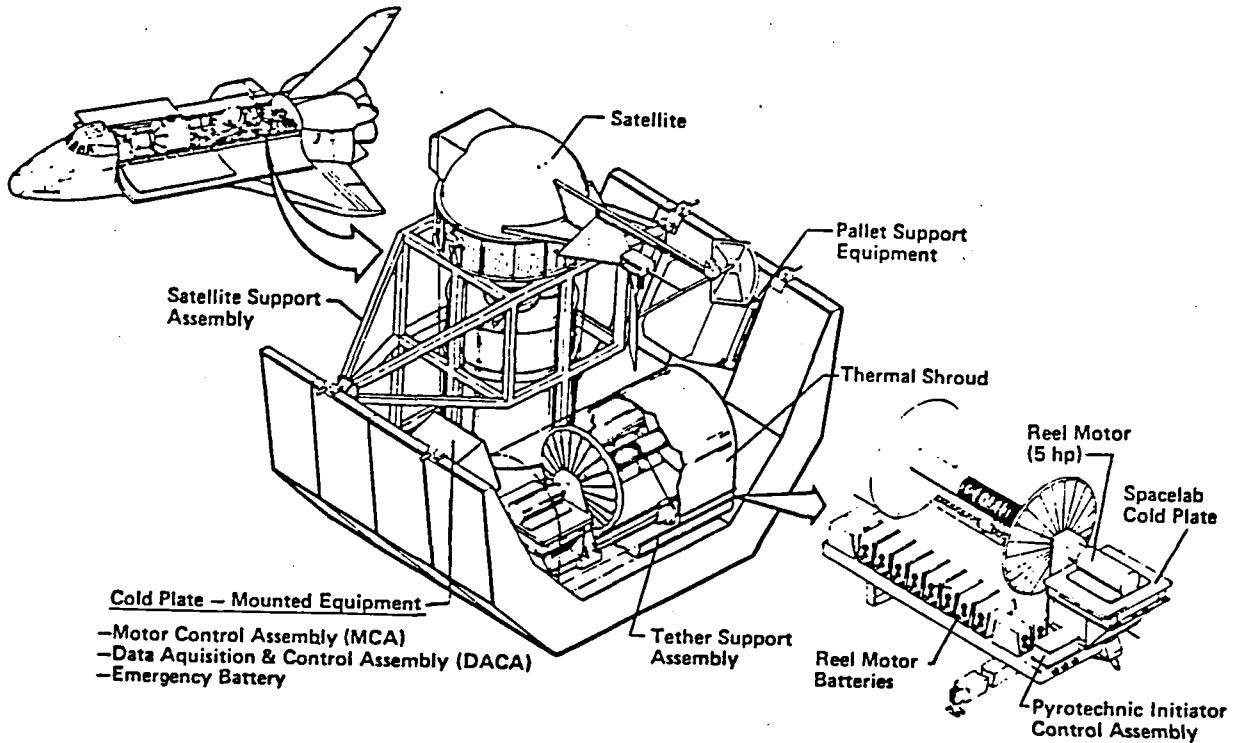

Figure 4. Design Overview - TSS/Pallet/Orbiter Interface

A tether support assembly is provided which supports the tether reel, 5-horsepower, brushless reel drive motor, and a battery bank which supplies a 170 VDC power source for the motor. A heated thermal shroud surrounds the batteries and various tether mechanisms. The pyrotechnic initiator control assembly is used under emergency conditions for severing the tether or jettisoning the satellite deployment boom.

Electronic equipment located on the cold plate includes the Motor Control Assembly (MCA) and the Data Acquisition and Control Assembly (DACA), which is the TSS-dedicated computer. The emergency battery is provided as a backup to Orbiter power for operating the pyrotechnic circuits if required.

Tether Control Mechanisms

Figure 5 schematically illustrates the tether control mechanisms, which include the reel drive, and upper and lower boom tether control mechanisms.

The reel assembly has been generously designed to accommodate a wide variety of tether diameters (1-3 mm) and lengths. The tether reel capacity chart in Fig. 5 illustrates the various combinations of tether diameters and lengths which can be accommodated. A slip ring assembly is included which is used for transferring the electric current flowing in the conductive tethers required for the electrodynamic satellites to other science instruments located on the pallet.

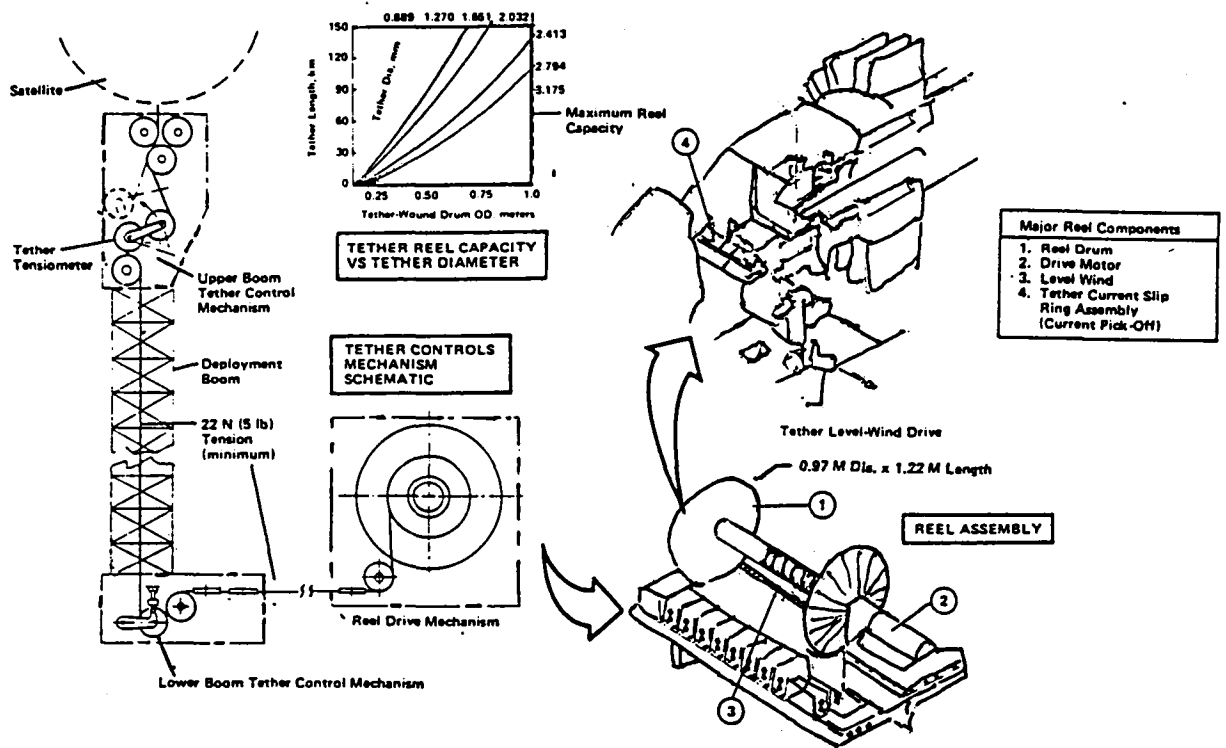

Figure 5. Design Overview - Tether Control Mechanisms

The lower boom mechanism located beneath the satellite deployment boom canister contains a tensiometer for measuring tether tension, and a tether measurement wheel for tracking the quantity of deployed and retrieved tether. The primary function of the upper boom tether control mechanism is to provide a positive drive tension to the tether during the phases of flight when the deployed satellite is within approximately 10 km (6 mi) of the Orbiter and the gravity gradient tension in the tether is less than approximately 22 Newtons (5 lb).

Tether Materials

Both electrically conductive and nonconductive tethers will be required for the TSS. Most of the tether designs considered to date are based around Kevlar-29, which has a very high strength-to-weight ratio, a wide temperature operating range (-100 to +200°C), and reasonably good mechanical fatigue properties. Table 1 provides a list of tether configurations currently being evaluated for the TSS. The various jackets and coatings will be tested for effectiveness against ultraviolet and atomic oxygen degradation.

Electrical Interfaces

Figure 6 schematically illustrates the TSS electrical interfaces.

TABLE 1
CANDIDATE TETHER CONFIGURATIONS

Type	Conductor	Jacket	Diameter In/mm	Weight Lb/1000 Ft/Kg/Km	Breakstrength Lb/Newtons
B29/12 X 15	None	None	0.065/1.65	1.35/2.0	650/2841
"	"	"	"	"	"
"	"	Silicone Dip	0.068/1.73	1.80/2.68	"
"	"	Teflon Braid	0.075/1.91	3.25/4.85	"
"	"	Kevlar Braid	0.087/2.21	2.75/4.10	"
"	"	Nomex Braid	0.085/2.16	2.70/4.03	"
Electrodynamic					
B29/12 X 10	24 AWG*	None	0.075/1.91	3.60/5.37	400/1779
B29/12 X 10	24 AWG*	Teflon Braid	0.102/2.59	5.60/8.35	400/1779

*Insulated with 0.38 mm (0.15 in.) polyethylene

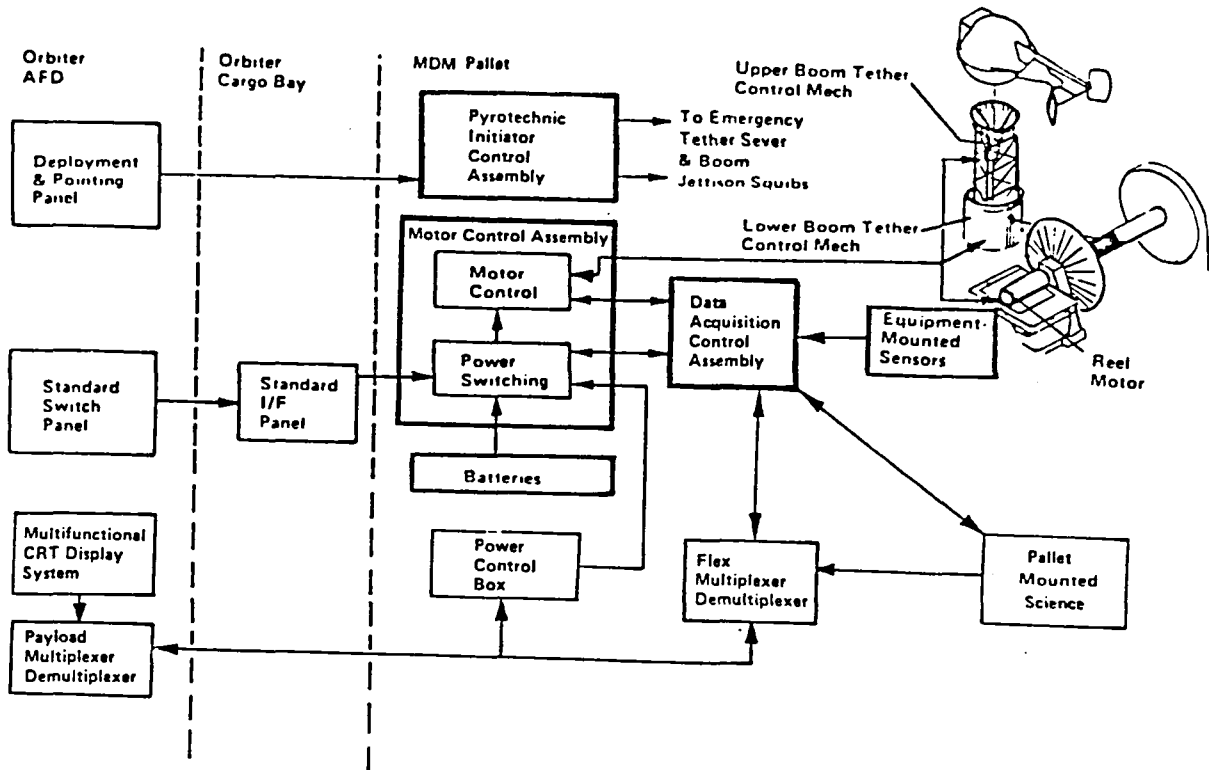

Figure 6. Design Overview - TSS Electrical Interfaces

As previously described, TSS control originates from the Orbiter Aft Flight Deck (AFD). The Deployment and Point Panel is used in a manual mode only for the emergency severing of the Orbiter-to-Satellite tether (2 places) or for jettison of the satellite deployment boom. The Standard Switch Panel is used primarily for "powering up" the system and performing special functions.

Most control and display functions will be accomplished by the mission specialist or payload specialist using the Multifunctional CRT Display System which interfaces with the TSS computer, the Data Acquisition and Control Assembly (DACA). The DACA contains the control algorithms required for computing all deployer and satellite control functions, provides analog/digital and digital/analog conversions, and controls the formatting of all telemetry data. It interfaces with the satellite through the Orbiter avionics and computers, and through the Orbiter S-Band Payload Interrogator. The DACA also interfaces with deployer-mounted science instruments.

The Motor Control Assembly (MCA) provides power switching functions, controls 2 brushless tether control motors, and 7 smaller motors, and provides for miscellaneous signal conditioning as required.

Demonstration Flight Satellites (Additional Data To Be Provided by Aeritalia During This Workshop)

The satellite for the first demonstration flight will be furnished by the Italian Council for National Research and will be developed by Aeritalia. The first flight is currently baselined as an electrodynamics mission. The 1.5 m diameter satellite will have a mass of approximately 500 kg. Its outer surface will be electrically conductive, and will be electrically connected (through control instrumentation) to the conductive tether. At the deployer end of the tether, the tether current will be passed through slip rings to the pallet-mounted science instruments and to a fast pulse electron gun which will route the current back to the space plasma. Figure 7 conceptually illustrates the electrodynamics satellite and the pallet-mounted science instruments for this mission.

Following completion of the electrodynamics mission, the satellite will be refurbished and configured for the atmospheric probe mission. Figure 8 illustrates a potential concept for the atmospheric probe. The currently defined science instruments anticipated for the first two missions are tabulated in Table 2.

The satellite subsystem includes the following:

- (1) Structure
- (2) Thermal Control
- (3) Attitude Measurement and Control
- (4) Propulsion
- (5) Telemetry, Tracking and Command
- (6) On-Board Data Handling
- (7) Electrical Power and Distribution.

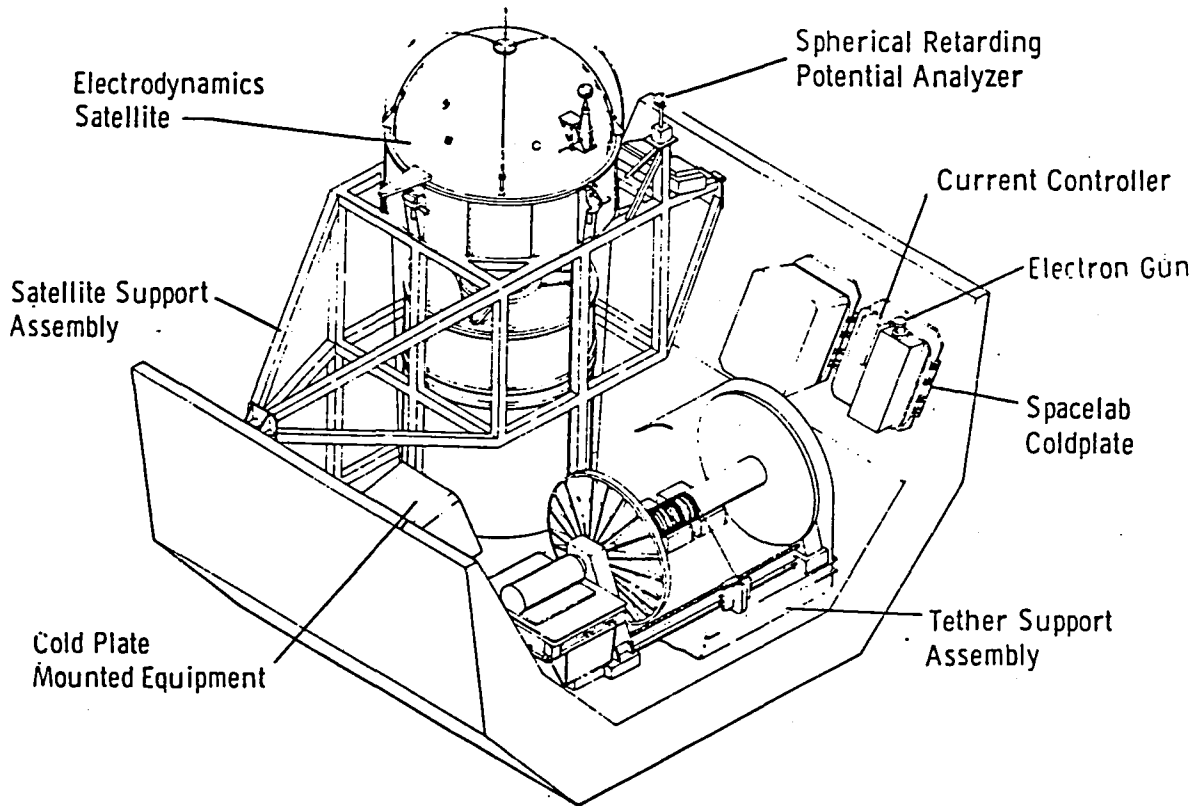

Figure 7. Design Overview - Electrodynamic Satellite

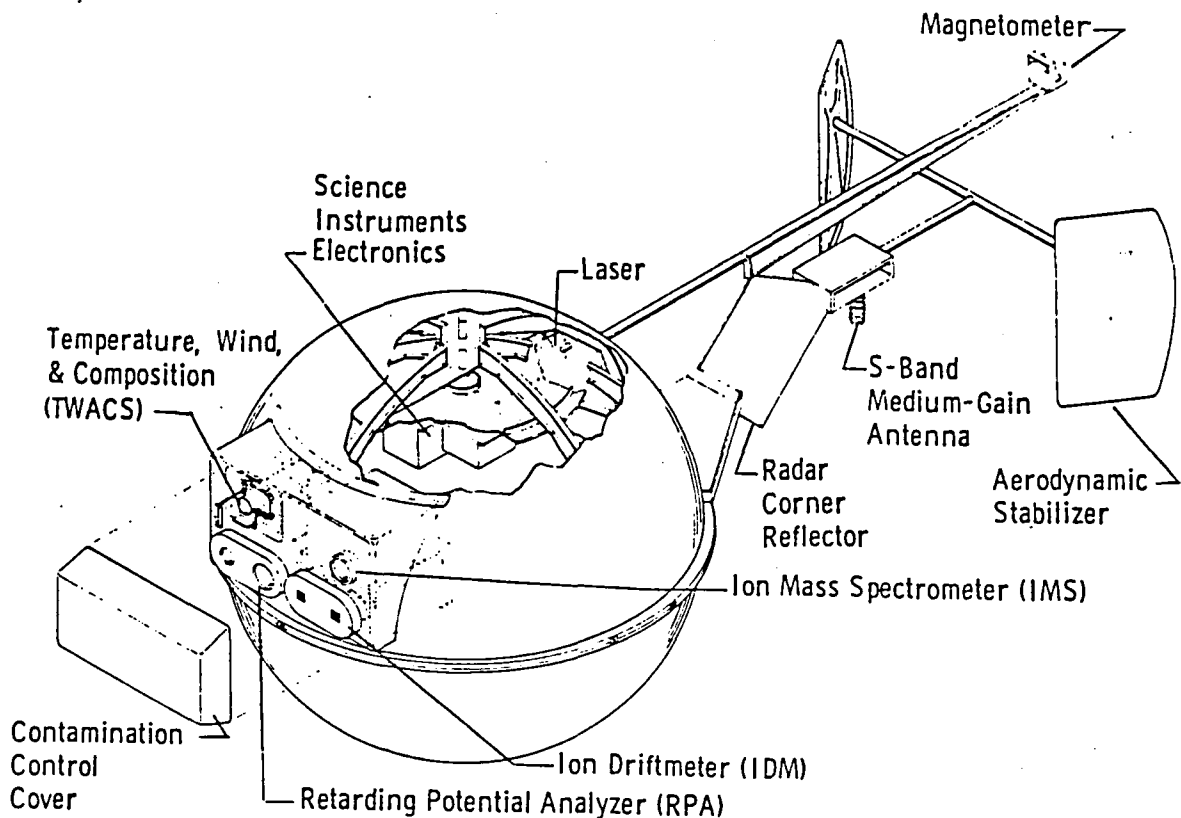

Figure 8. Design Overview - Atmospheric Probe Satellite

TABLE 2
DEMONSTRATION FLIGHTS SCIENCE INSTRUMENTS

Electrodynamics	Atmospheric Probe
Current Monitor	Temperature, Wind & Composition
Voltage Monitor	Ion Drift Meter
Current Probe	Ion Mass Spectrometer
Charge Probe	Retarding Potential Analyzer
Photometer	Magnetometer
Langmuir Probe	Ion Probe
Spherical Retarding Potential Analyzer	
Suprathermal Electron Spectrometer	
Search Coil Magnetometer	
Wave and Plasma Probes	

Tethered Satellite Demonstration Flight System Capabilities

The Tethered Satellite System is capable of accommodating a wide variety of scientific payloads, both on the deployed satellite and on the stationary, Orbiter-mounted deployer. A preliminary listing of the combined capabilities is provided in Table 3.

TABLE 3
TETHERED SATELLITE SYSTEM DEMONSTRATION FLIGHT CAPABILITIES

Parameter	Satellite	Deployer
Maximum Total Mass (kg)	500	2100
Scientific Payload Mass (kg)	60-80	500
Payload Volume	Negotiable (1.5m Diam)	Negotiable (Spacelab MDM Pallet)
Temperature (°C)	-10 to +50	Negotiable
Thermal Control (Watts)	50 (Passive)	2 Coldplates @ 1500 Ea.
Power @ 28 ± 4 VDC		
Average (Watts)	50	500-1000
Peak (Watts)	100	1500
Energy (Watt-Hrs)	900-2000	36,000
Data		
Telemetry (KBPS)	6-12	300-400
Commands (KBPS)	2	Flexible
Operational Altitudes (Km)	130 and Above	Up to 100 km Tether
Orbital Inclination	Any	Any
Mission Duration (Hrs)	36	36
Position Determ. (Rel. to Orbiter)		-
Range	±1%	-
Angular	±2°	-
Attitude Control		
Pitch, Roll	±2°	-
Yaw	±3°	-
Attitude Measurement	±0.1 to ±0.3°	-

TSS SATELLITE OVERVIEW

Gianfranco Manarini

The responsibilities of NASA and PSN/CNR on the TSS Cooperative Program.



PSN/CNR-AIT has completed a series of system support and technological studies.



NASA - PSN/CNR RESPONSIBILITIES ON TSS COOPERATIVE PROGRAM

N A S A

- MANAGEMENT OF THE OVERALL SYSTEM
- ADVANCED DEVELOPMENT PHASE
- DEPLOYER DEVELOPMENT AND TEST
- OVERALL SYSTEM INTEGRATION AND TEST
- OVERALL SYSTEM OPERATIONS

PSN/CNR

- SATELLITE MANAGEMENT
- SYSTEM SUPPORT STUDIES
- TECHNOLOGICAL STUDIES
- SATELLITE DEFINITION AND DESIGN
- SATELLITE DEVELOPMENT AND TEST
- PAYLOAD INTEGRATION INTO SATELLITE

TSS SCIENCE EXPERIMENTS ADDRESSED BY A JOINT U.S./ITALIAN SCIENCE
WORKING GROUP (SWG)

- U.S. RESPONSIBLE FOR U.S. AND NON-EUROPEAN SCIENCE INVESTIGATIONS
- ITALY RESPONSIBLE FOR ITALIAN AND OTHER EUROPEAN SCIENCE INVESTIGATIONS

PSN/CNR-AIT SYSTEM SUPPORT STUDIES

- ACTIVE VS. PASSIVE SATELLITE TRADE-OFF STUDY
- ANALYSIS OF ALTERNATIVE MANOEUVRES
- SATELLITE ATTITUDE AND POSITION DETERMINATION ANALYSIS
- FAILURE MODES ANALYSIS

PSN/CNR-AIT TECHNOLOGICAL STUDIES

- MOVABLE BOOM DYNAMIC ANALYSIS
- DOUBLE TETHERED SATELLITE SYSTEM
- THERMO/DYNAMIC ANALYSIS FOR 100-120 KM ALTITUDE RANGE

The results of the Active vs. Passive Satellite Trade-Off Study are listed. The active satellite configuration is characterized by tether line thrusters for added artificial gravity and by equatorial thrusters to damp the in-plane or out-of-plane oscillations for a fast satellite retrieval. The passive configuration is mainly controlled by the tether control law and the orbiter by maneuvers, damping out the oscillations for the same fast retrieval as in the active configuration. The trade-off study has covered system evaluation actions like position determination, low tension control mode, propellant consumption and dynamic analyses (stability during the retrieval). Based on the Aeritalia/Marshall Space Flight Center Study, the NASA/PSN conclusions can be summarized as the two systems are dynamically equivalent. They can both be made to operate safely for the orbiter. The active system is more complex in terms of basic design and safety for orbiter software. The system offers faster retrieval capability and potential design advantages, for example, deployment initiation with artificial tether tension. The passive system offers a greater payload mass/volume capability.



The active system has a greater maneuverability which is an advantage for future potential users and for the TSS concept application for the space station. The active system does not prevent the passive mode capability. The NASA/PSN design guidelines were mainly to include within the deployer and the orbiter system the capability to control an active satellite with the exception of the final stage of retrieval which must be compatible with the passive mode.



ACTIVE VS. PASSIVE SATELLITE TRADE-OFF STUDY

- SYSTEM EVALUATIONS
 - POSITION DETERMINATION
 - LOW-TENSION CONTROL MODE
 - PROPELLANT CONSUMPTION
 - DYNAMIC ANALYSIS
 - RETRIEVAL PHASE STABILITY ANALYSIS
 - IMPACT OF INITIAL CONDITIONS AND TIME CONSTANTS ON PROPELLANT CONSUMPTION AND REEL-MOTOR ELECTRICAL POWER
 - POTENTIAL MALFUNCTION-MODES EVALUATION
 - SATELLITE ATTITUDE DYNAMIC RESPONSE TO THRUSTER MISALIGNMENTS AND ORBITER OUT-OF-PLANE MANOEUVRES
 - NASA/PSN CONCLUSIONS
 - THE DYNAMICS OF BOTH SYSTEMS ARE EQUIVALENT (PASSIVE CONFIGURATION INVOLVES ORBITER MANOEUVRES FOR FAST RETRIEVAL)
 - BOTH SYSTEMS CAN BE MADE TO OPERATE SAFELY
 - THE ACTIVE SYSTEM IS MORE COMPLEX (BASIC DESIGN, SAFETY MEASURES, ORBITER SOFTWARE)
 - THE ACTIVE SYSTEM OFFERS FASTER RETRIEVAL CAPABILITY, POTENTIAL DESIGN ADVANTAGES (IN TERMS OF TETHER TENSION ENHANCEMENT, DEPLOYMENT INITIATION)
 - THE PASSIVE SYSTEM OFFERS GREATER MASS/VOLUME PAYLOAD CAPABILITY
-

ACTIVE VS. PASSIVE SATELLITE TRADE-OFF STUDY (CONT.)

- NASA/PSN CONCLUSIONS (CONT.)
 - THE ACTIVE SYSTEM OFFERS GREATER SATELLITE MANEUVERABILITY
 - GREATER POTENTIAL FOR USER INTERACTION
 - GROWTH ORIENTED FOR "TSS CONCEPT" APPLICATIONS CONNECTED WITH FUTURE SPACE STATIONS
 - THE ACTIVE SYSTEM DOES NOT PREVENT THE PASSIVE MODE CAPABILITY
- NASA/PSN DESIGN GUIDELINES
 - INCLUDE CAPABILITY WITHIN THE DEPLOYER AND ORBITER SYSTEM TO CONTROL AN ACTIVE (THRUSTING) SATELLITE DURING ALL BUT FINAL STAGES OF RETRIEVAL
 - DEVELOP AN ACTIVE (THRUSTING) SATELLITE COMPATIBLE WITH PASSIVE CONTROL DURING FINAL STAGES OF RETRIEVAL
 - CONSIDER MODULAR (REMOVABLE) PROPELLANT TANKAGE FOR LARGE MASS/VOLUME SCIENCE MISSION REQUIREMENTS

A summary of Analysis of Alternative Maneuvers is shown here. This dynamic study has been related to all of the phases of the mission, such as deployment, stationkeeping and retrieval. Its purpose was to achieve improved performance, but within the safety and engineering constraints. The deployment strategy involved the selection of the initial velocity vector. Six subphases controlled in tension or rate were defined. Advantages were a shorter deployment time and a lower propellant consumption, better starting conditions for the subsequent stationkeeping phase such as the strategy of optimized control parameters like the commanded length, time constant, argument of latitudes, damping factors and stiffness. The relative advantages were the shorter transition time and the smaller in-plane overswing. The retrieval strategy was a modified tension law which added a transition rate law and included additional factors in the tension rate, and thrusters laws. The advantages were a shorter retrieval time and a lower propellant consumption.



In the Satellite Attitude and Position Determination Analysis, a six degree-of-freedom mathematical model was developed with tether distributed mass, straight line, and unelastic. As to external torques, they were aerodynamic, thruster, restoring and thruster misalignment. The dynamic study indicated no specific critical behavior or instability. An active yaw control system is necessary during the retrieval phase because the aerodynamic drag is not capable of stabilizing the thruster misalignment torques.



ANALYSIS OF ALTERNATIVE MANOEUVRES

- DYNAMIC STUDY RELATED TO EACH PHASE OF THE MISSION AIMING TO ACHIEVE IMPROVED PERFORMANCES WITHIN THE SAFETY AND ENGINEERING CONSTRAINTS

<u>PHASE</u>	<u>STRATEGY</u>	<u>ADVANTAGES</u>
DEPLOYMENT	<ul style="list-style-type: none">• SELECTION OF INITIAL VELOCITY VECTOR• DEFINITION OF SIX SUB-PHASES CONTROLLED IN TENSION OR RATE	<ul style="list-style-type: none">• SHORTER DEPLOYMENT TIME• LOWER PROPELLANT CONSUMPTION• BETTER STARTING CONDITIONS FOR STATION-KEEPING
STATION-KEEPING	<ul style="list-style-type: none">• OPTIMIZED CONTROL PARAMETERS (ARGUMENT OF LATITUDE, COMMANDED LENGTH TIME CONSTANT, STIFFNESS, DAMPING FACTOR)	<ul style="list-style-type: none">• SHORTER TRANSITION TIME• SMALLER IN-PLANE OVERSWING
RETRIEVAL	<ul style="list-style-type: none">• MODIFIED TENSION LAW• ADDED TRANSITION RATE LAW• INCLUDED ADDITIONAL FACTORS IN THE TENSION, RATE, THRUSTERS LAWS (TAKING ADVANTAGE OF THE BOOM PRESENCE)	<ul style="list-style-type: none">• SHORTER RETRIEVAL TIME• LOWER PROPELLANT CONSUMPTION

SATELLITE ATTITUDE AND POSITION DETERMINATION ANALYSIS

- IMPLEMENTED A SIX DEGREES OF FREEDOM MATHEMATICAL MODEL
 - TETHER DISTRIBUTED MASS, STRAIGHT LINE, UNELASTIC
 - EXTERNAL TORQUES : AERODYNAMIC, THRUSTER, RESTORING (DUE TO TETHER TENSION), THRUSTER MISALIGNMENT
- GENERAL CONCLUSIONS
 - DYNAMIC ANALYSIS INDICATED NO SPECIFIC CRITICAL BEHAVIOR OR INSTABILITIES
 - ACTIVE YAW CONTROL IS NECESSARY BECAUSE AERODYNAMIC TORQUES ARE NOT ABLE TO STABILIZE THE MISALIGNMENT THRUSTER TORQUES

The Failure Mode Analysis considered four failure modes involving tether elasticity.



Two failure modes for a rigid tether were examined.



FAILURE MODES ANALYSIS

- FAILURE MODES INVOLVING TETHER ELASTICITY

- TETHER LONGITUDINAL VIBRATIONS (POSSIBLY EXCITED DURING TRANSIENT STAGES OF MANOEUVRES) DO NOT INCREASE THEIR AMPLITUDES IF TENSION IS MAINTAINED. VIBRATORY COMPONENTS OF MOTION EXPECTED TO DECREASE AND ULTIMATELY TO SLOWLY VANISH
 - SUDDEN REELING MECHANISM STOP (FAILURE) DURING DEPLOYMENT OR RETRIEVAL CAUSES TETHER SLACKNESS
 - FOR SHORT DEPLOYED TETHER LENGTH, AN IN-LINE THRUSTER FAILURE OR THE COUPLING BETWEEN SATELLITE SWINGING MOTION AND TETHER VIBRATIONS CAN CAUSE TENSION LOSS (COUPLING COULD BE PREVENTED BY DAMPER ON SATELLITE)
 - THE SEVERED TETHER CONNECTED WITH THE ORBITER COULD ACQUIRE ENERGY TO GET ENTANGLED IN SOME ORBITER APPENDAGES
-

FAILURE MODE ANALYSIS (CONT.)

- FAILURE MODES - RIGID TETHER

- UNEXPECTED IN-PLANE OR OUT-OF-PLANE THRUSTER SHUT-OFF IN RESPECTIVELY TOLERATED WITHIN 20 MT OR 4 KM FROM THE ORBITER. OTHERWISE (NOT TOLERATED) THE TIME FOR AN EMERGENCY ACTION RANGES FROM 1 TO 2 HR DEPENDING ON TETHER LENGTH
- UNEXPECTED IN-PLANE OR OUT-OF-PLANE THRUSTER FAILS OPEN IS NEVER TOLERATED UNLESS PROVISIONS FOR BACK-UP SOLUTIONS ARE PROVIDED. TIME FOR AN EMERGENCY ACTION RANGES RESPECTIVELY FROM 4 MIN (AT 500 MT) TO 70 SEC (AT 20 MT) AND FROM 1.5 HR (AT 20 KM) TO 70 SEC (AT 20 MT)

The purpose of the Movable Boom Dynamic Analysis was to verify the impact and the effectiveness of the movable boom on the satellite dynamics in the orbiter vicinity. An appropriate boom control law both in-plane or out-of-plane has been derived to optimize the damping of the satellite oscillations. As a result, the defined minimum boom length to satellite distance ratio which limits the boom effectiveness on the satellite dynamics was defined. Shorter retrieval time could be achieved by operating the boom out of plane.



A double tethered satellite system means a secondary satellite released from the deployed primary satellite. A mathematical model and computer program have been implemented to perform simulations and the secondary satellite deployment and retrieval maneuvers have been simulated in order to derive the systems dynamics which control the strategy and the optimum secondary satellite mass and tether length. In addition, two retrieval failure modes were studied. These are the primary tether break and the reel mechanism jam. The general conclusions are: an easy, simple, and fast secondary satellite release; a control strategy for complete, safe and fast secondary satellite retrieval in the passive mode, and that the failure mode seems to exclude collision with the orbiter.



MOVABLE BOOM DYNAMIC ANALYSIS

- TO INVESTIGATE EFFECTIVENESS AND IMPACT OF A MOVABLE BOOM ON THE SATELLITE DYNAMICS IN THE ORBITER VICINITY
 - DERIVED SUITED BOOM CONTROL LAWS (IN-PLANE AND OUT-OF-PLANE) IN ORDER TO OPTIMIZE THE SATELLITE OSCILLATIONS DAMPING
 - RESULTS
 - DEFINED (PARAMETRIC ANALYSIS) THE MINIMUM "BOOM LENGTH TO SATELLITE DISTANCE" RATIO WHICH LIMITS THE BOOM EFFECTIVENESS ON THE SATELLITE DYNAMICS
 - SHORTER RETRIEVAL TIME BY OPERATING THE BOOM OUT-OF-PLANE
 - DUALITY OF THE SATELLITE DYNAMIC BEHAVIOR FOR A FIXED BOOM AND A ROTATING ORBITER
-

DOUBLE TETHERED SATELLITE SYSTEM

- DEVELOPED A NEW MATHEMATICAL MODEL AND COMPUTER PROGRAM TO PERFORM SIMULATIONS
- SIMULATED "SECONDARY SATELLITE" RETRIEVAL IN ORDER TO DERIVE
 - SYSTEM DYNAMICS
 - CONTROL STRATEGY
 - OPTIMUM "SECONDARY SATELLITE" MASS AND TETHER LENGTH
- ANALYSIS OF THE "SECONDARY SATELLITE" DEPLOYMENT MANOEUVRE
- STUDY OF TWO RETRIEVAL FAILURE MODES
 - PRIMARY TETHER BREAK
 - REEL MECHANISM JAM
- RESULTS
 - SIMPLE AND FAST "SECONDARY SATELLITE" RELEASE
 - CONTROL STRATEGY ALLOWS COMPLETE, FAST, SAFE RETRIEVAL (PASSIVE) OF THE "SECONDARY SATELLITE"
 - FAILURE MODE STUDY SEEMS TO EXCLUDE COLLISION RISK WITH ORBITER
- DOUBLE TETHERED SATELLITE UTILIZATION SEEMS ATTRACTIVE

In spite of the very severe aerodynamic heat on the external skin of the satellite, it is possible to control the internal temperature by appropriate thermal control design or components like specific heat shields. Further investigation must be performed especially on the non-metallic materials for thermal protection. The major constraints are related to the total mass of the satellite which must be maintained within required limits. In the dynamic analysis, it was necessary to refine the modelization of the last 10 km of the tether. The simulations indicated stable dynamic response for a maximum tether length corresponding to 110 km.



For the most critical and severe conditions the amplitude of the in-plane oscillations ranges between quite high values and the aerodynamic drag induces an orbiter decay of about 15 km after about 3 orbits. As a preliminary conclusion, it appears that the reasonable value of about 110 km altitude could be achievable with acceptable in-plane oscillation and orbiter propellant consumption for the altitude make-up maneuvers.



THERMO-DYNAMIC ANALYSIS FOR 100-120 KM ALTITUDE RANGE

- THERMO ANALYSIS

- SEVERE AERODYNAMIC HEATING; EXTERNAL SKIN TEMPERATURE IN THE STAGNATION REGION CAN REACH VALUES ABOVE 1100 °C
- POSSIBILITY TO CONTROL THE INTERNAL TEMPERATURE BY APPROPRIATE THERMAL CONTROL COMPONENT AND DESIGN
- FURTHER ANALYSIS TO BE PERFORMED ESPECIALLY IN THE AREA OF NON-METALLIC THERMAL PROTECTION MATERIALS
- MAJOR CONSTRAINT RELATED TO SATELLITE WEIGHT (TO BE MAINTAINED WITHIN THE REQUIRED LIMIT)

- DYNAMIC ANALYSIS

- REFINED MODELIZATION OF THE LAST SEGMENT (10 KM) OF THE TETHER
- SIMULATIONS SHOW A STABLE SATELLITE DYNAMIC RESPONSE FOR A MAXIMUM TETHER LENGTH OF 110 KM

THERMO-DYNAMIC ANALYSIS FOR 100-120 KM ALTITUDE RANGE (CONT.)

- DYNAMIC ANALYSIS (CONT.)

- AMPLITUDE OF IN-PLANE OSCILLATIONS RANGES FROM 51 DEG BACKWARD TO 22 DEG FORWARD
 - AERODYNAMIC DRAG INDUCES AN ORBITER DECAY OF ABOUT 15 KM AFTER 3 ORBITS
 - REASONABLE VALUE OF 110 KM ALTITUDE APPEARS TO BE ACHIEVABLE WITH ACCEPTABLE IN-PLANE OSCILLATIONS AND ORBITER PROPELLANT CONSUMPTION
- POTENTIAL SCIENCE APPLICATIONS FOR DIRECT LONG-TERM OBSERVATION IN A REGION WHERE FLIGHT DATA ARE UP TO NOW LIMITED BY VERY SHORT MISSION DURATION

The next charts outline program objectives. The TSS system must be capable of towing a 500 km satellite in high or low earth orbit after an upward or downward deployment up to 100 km of tether length. It must also provide a retrieval and recovery capability with associated low recurring costs. Control in a closed loop motion provides long-term access up to altitudes as low as 130 km. This is the actual tether configuration, of course. A dedicated control panel will cover the TSS atmospheric observation here outlined, and the space plasma observation indicated in the next chart.



The possible TSS applications include electrical power; peak power or emergency power; electromotive force generation; VLF communications; microgravity experiments; earth observations; experimental data collection for reentry and aerobrakes; and chemical releases.



OBJECTIVES OUTLINE

- SYSTEM

DEVELOP A SYSTEM TO ENABLE A SATELLITE TO BE TETHERED AT DISTANCES UP TO 100 KM FROM THE ORBITER

- DEPLOYMENT TOWARD OR AWAY FROM EARTH
- RETRIEVAL AND RECOVERY CAPABILITY
- CLOSED LOOP MOTION CONTROL
- LONG-TERM ACCESS TO LOW ALTITUDES

- ATMOSPHERIC SCIENCE

- THERMOSPHERE STRUCTURE AND DYNAMICS
- ELECTRIC CURRENTS IN THE THERMOSPHERE
- ELECTRIC FIELDS AND ION-NEUTRAL COUPLING
- MIDDLE ATMOSPHERE COUPLING
- TRACE CONSTITUENT CHEMISTRY

OBJECTIVES OUTLINE (CONT.)

- SPACE PLASMA SCIENCE

- ARTIFICIAL GENERATION OF HYDROMAGNETIC WAVES
- CURRENT-DRIVEN INSTABILITIES
- PLASMDYNAMIC INTERACTIONS
- VLF, ELF WAVE GENERATION AND WAVE-PARTICLE INTERACTIONS
- LONG-WIRE ANTENNAS IN MAGNETOPLASMAS
- SIMULATION OF CELESTIAL BODY ELECTRODYNAMICS

- APPLICATIONS

- HIGH ELECTRIC POWER GENERATION
- ELECTROMOTIVE FORCE GENERATION
- ULF COMMUNICATIONS
- MICROGRAVITY EXPERIMENTS
- EARTH OBSERVATIONS
- RE-ENTRY AND AEROBRAKES DATA TEST
- CHEMICAL RELEASES

This TSS Satellite Configuration is a modular design approach for the satellite in order to minimize the modifications required to accommodate the payload selected for different missions.



Specific configuration requirements for deployment between 150 and 130 km altitude include thermal control provision for insulation and an aerodynamic stabilizer. The double satellite system is an alternative configuration capability.



TSS SATELLITE CONFIGURATION

- MODULAR DESIGN APPROACH IN ORDER TO MINIMIZE MODIFICATIONS REQUIRED TO ACCOMMODATE THE PAYLOAD SELECTED FOR EACH MISSION

SERVICE MODULE

- MULTIPURPOSE HEMISPHERICAL MODULE
- CONTAINS ALL SUBSYSTEMS
- SHARED BY A WIDE VARIETY OF MISSIONS

PROPULSION MODULE

- REMOVABLE TO SATISFY LARGE MASS/VOLUME PAYLOAD REQ.'S

PAYLOAD MODULE

- HEMISPHERICAL OR ANY OTHER GEOMETRY
- RE-CONFIGURED TO MEET PAYLOAD REQUIREMENTS
- ACCOMMODATES UP TO 80 KG OF SCIENTIFIC INSTRUMENTS

- DURING FINAL STAGE OF RETRIEVAL AND/OR IN THE "REMOVED PROPULSION MODULE CONFIGURATION", THE SATELLITE IS CONTROLLED IN PASSIVE MODE
 - BY TETHER LAWS
 - BY ORBITER ATTITUDE MANEUVERS WHICH PROVIDE THE EQUIVALENT OSCILLATION DAMPING FOR A FAST RETRIEVAL

TSS SATELLITE CONFIGURATION (CONT.)

- CONFIGURATION REQUIREMENTS FOR DEPLOYMENT BELOW 150 KM ALTITUDE
 - THERMAL CONTROL PROVISIONS (MULTILAYER INSULATION)
 - AERODYNAMIC STABILIZER
- ALTERNATIVE CONFIGURATION PROVIDES CAPABILITY TO DEPLOY A PAYLOAD PACKAGE OR A BALLAST MASS FROM THE DEPLOYED SATELLITE (DOUBLE TETHERED SATELLITE SYSTEM)

This chart indicates the programmatic aspects. Phase B which consists of system, subsystem, and GSE activities has been practically completed. The Phase B will be followed by a bridging phase for system and subsystem finalization.



This chart continues the bridging phase activities which follow the Phase B and the subsequent Phase C/D .



TSS SATELLITE PROGRAM

- PHASE B

SYSTEM ACTIVITIES

- REQUIREMENT, CONFIGURATION, SPECIFICATION, GENERAL DESIGN AND INTERFACE REQUIREMENTS
- SYS/TECHNOL. STUDIES, TECHNICAL NOTES, SYS I/F ANALYSIS
- AIV, PA, CONFIGURATION AND DATA MANAGEMENT PLANS, DOCUMENTATION TREE
- SUPPORT DOCUMENTS TO SWG, EXP'S ACCOMODATION HANDBOOK, EXPERIMENTS LOCATION (BOTH MISSIONS)

SUBSYSTEMS AND GSE ACTIVITIES

- REQUIREMENTS, SPECIFICATIONS, CONCEPTUAL DESIGNS, DRAWINGS
- DEVELOPMENT AND TEST PLANS

- BRIDGING PHASE

SYSTEM FINALIZATION

- SPECIFICATION, SYS INTERFACES, PLANS, DOCUMENTATION TREE
- DYNAMICS, OPERATIONS (GROUND AND FLIGHT)

SUBSYSTEMS AND GSE FINALIZATION

- SPECIFICATIONS, DESIGNS, DRAWINGS
 - EXPERIMENTS LOCATION AND I/F DEFINITION (BOTH MISSIONS)
-

TSS SATELLITE PROGRAM (CONT.)

- BRIDING PHASE (CONT.)

TECHNOLOGICAL ASSESSMENTS

- THERMAL DECOUPLING TESTS
- SURFACE FINISH (PROCESS, CHARACT.'S EVAL., THERMAL TESTS)
- PROPELLANT TANK HEAT TRANSFER SIMULATION

ADVANCE PHASE C/D ACTIVITIES

- STRUCTURAL MODEL DESIGN
- THERMAL MODEL DESIGN
- TOOLS DESIGN AND MANUFACTURING
- MATERIAL PROCUREMENT FOR STRUCTURAL AND THERMAL MODELS
- LONG LEAD ITEMS PROCUREMENT
- PHASE C/D PLANS

PHASE C/D PROPOSAL (INCLUDING SECOND MISSION)

- PHASE C/D

- MANUFACTURING, ASSY, INTEGRATION AND TEST

This chart lists the major program milestones. Phase B started 1 August 1981. The Baseline Design Review Meeting started 30 May and will be completed within the month. The subsequent Bridging Phase ATP is scheduled for June 1983, the Phase C/D proposed by late November or early December of this year, with a final review by March 1984. Phase C/D ATP starts 1 April 1984. The other indicated milestone dates are now under evaluation and are subject to change.



This chart summarizes the PSN/Aeritalia studies related to the TSS application to the Space Station. The first study was a deployment, stationkeeping and a retrieval of satellites by using the improved TSS configuration with less critical constraints than the ones imposed by the orbiter in terms of satellite mass, tether deployment length, and mission duration. Other studies include: tethered teleoperator maneuvering system studies; a rendezvous and docking facility for the Space Station; payload transfer to higher or lower energy orbits; stationkeeping with a possibility of modifying some orbital parameters; fluid transfer by gravity gradient; tether space architecture; and utilization of the external tanks. The wind tunnel facility will be related to the present TSS configuration for the acquisition of additional experimental data for reentry and aerobraking.



TSS SATELLITE MILESTONES

- PHASE B
 - ATP 1, AUGUST - 81
 - BASELINE DESIGN REVIEW (BDF) 30 MAY/1 JUNE - 83

 - BRIDGING PHASE
 - ATP JUNE - 83
 - PHASE C/D PROPOSAL DECEMBER - 83
 - FINAL REVIEW MARCH - 84

 - PHASE C/D
 - ATP 1, APRIL - 84
 - PREL. REQ.'S REVIEW (PRR) 1, MAY - 84
 - PREL. DESIGN REVIEW (PDR) 1, AUGUST - 84
 - CRITICAL DESIGN REVIEW (CDR) 1, MARCH - 85
 - ENG. MODEL AVL. AT MMA 1, MARCH - 86
 - EXP'S AVL. AT AIT 1, APRIL - 86
 - SATELLITE AVL. AT MMA 1, OCTOBER - 86

 - TSS AVAILABLE AT KSC 1, JANUARY - 87
 - FLIGHT 1 (FIRST MISSION) 30, APRIL - 87
 - FLIGHT 2 (SECOND MISSION) 30, APRIL - 88
-

TSS CONCEPT APPLICATION - PSN/AIT STUDIES

- DEPLOYMENT AND RETRIEVAL OF SATELLITES (IMPROVED TSS INTEGRATED INTO SPACE STATION)
- TETHERED TELEOPERATOR MANEUVERING SYSTEM
- RENDEZ-VOUS AND DOCKING FACILITY FOR SPACE STATION
- PAYLOAD TRANSFER TO HIGHER OR LOWER ENERGY ORBITS END RE-ENTRY
- STATION-KEEPING OF SPACE STATION AND POSSIBILITY OF MODIFYING THE ORBITAL PARAMETERS
- FLUID TRANSFER BY GRAVITY GRADIENT
- TETHER SPACE STATION ARCHITECTURES (LOW G FACILITY AND CONSTELLATION)
- UTILIZATION OF ET'S FOR TETHERED SPACE STATION
- WIND TUNNEL FACILITY FOR RE-ENTRY AND AEROBRAKES DATA TEST

SATELLITE MODULE DESIGN

Marcello Vignoli
Aeritalia

The basic requirements of the TSS satellite are a multimission vehicle able to carry scientific payload away from the Shuttle orbiter in the range of 130-330 nominal km, basing this figure on a 230 km shuttle orbit. The multimission capability is obtained by adopting a modular concept for the satellite. This allows easy reconfiguration mission by mission, easy refurbishment because the same service module performs both aerodynamic and atmospheric missions which are quite different and minimizes cost and schedule.



The modular concept is realized with a payload module (PM), an Auxiliary Propulsion Module (APM), and a service module (SM). These are three separate modules. For instance, the payload module is thermally separated from the other two modules in order to minimize the integration problem. The auxiliary propulsion module is a separate module to reduce the time of integration. The satellite is able to fly without any active thruster. The service module is the one that remains constant between all the missions both aerodynamic and electrodynamic. In the electrodynamic mission the satellite has a spin-up capability up to 1 rpm as required by the scientists. It can have a standard fixed boom for scientific instrumentation or a deployable boom furnished by the scientists. The capabilities to connect the conductive tether and the instruments and to vary the resistance between the satellite and the tether are required in some experiments. For atmospheric missions the satellite will not be spinning. It will be stabilized in yaw aerodynamically.



SATELLITE CONCEPT

- THE TSS-SATELLITE IS A MULTIMISSION VEHICLE ABLE TO CARRY SCIENTIFIC PAYLOADS AWAYS FROM THE SHUTTLE-ORBITER IN THE RANGE OF 130±330 KM IN ALTITUDE
 - THE MULTIMISSION CAPABILITY IS OBTAINED ADOPTING A MODULAR CONCEPT OF THE SATELLITE SUCH TO ALLOW FOR:
 - EASY RE-CONFIGURATION
 - EASY REFURBISHMENT
 - COST AND SCHEDULE MINIMISATION
-

SATELLITE CONCEPT (CONTINUED)

THE MODULAR CONCEPT IS REALIZED WITH:

- A PAYLOAD MODULE (PM)
- A SERVICE MODULE (SM)
- AN AUXILIARY PROPULSION MODULE (APM)

ELECTRODYNAMIC MISSION

- . SPIN-UP CAPABILITY
- . STANDARD FIXED BOOM FOR SCIENTIFIC INSTR.
- . CAPABILITY OF ELECTRICAL CONNECTION BETWEEN INSTRUMENTS AND TETHER

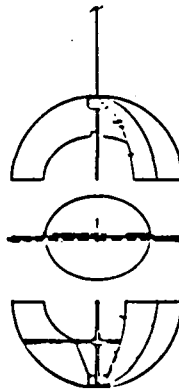

ATMOSPHERIC MISSION

- . AERODYNAMIC TAIL
- . PECULIAR THERMAL CONTROL
- . APM REMOVABLE AND REPLACEABLE WITH ADDITIONAL PAYLOAD (CHEMICAL RELEASE MISSION)

The main objectives of the TSS are to accomplish scientific experiments with instruments both on-board the satellite and on the deployer. However, in the two first missions particular attention will be given to demonstrate the feasibility of the tether concept in terms of the capability to deploy, maintain on station, and retrieve the satellite from the orbiter. This is priority one of the first two missions, the first electrodynamic and the second atmospheric. These missions plan to have a substantial payload in the satellite.



From the system verification point of view, two main objectives are to be achieved: (1) to demonstrate the capability of the combined action of the deployer (with suitable tether control laws) and of the satellite (with its thrusting capability) to control the satellite dynamics during the various mission phases, particularly during deployment and retrieval and (2) to demonstrate the capability of the satellite to withstand the atmospheric heating in the lower region of the atmosphere (130-150 KM of altitude above standard sea level).



MISSION OBJECTIVES

- THE MAIN OBJECTIVES OF THE TSS IS TO ACCOMPLISH SCIENTIFIC EXPERIMENT WITH INSTRUMENTS BOTH ON-BOARD OF THE SATELLITE AND ON THE DEPLOYER.

HOWEVER, IN THE TWO FIRST MISSIONS PARTICULAR DEVOTION WILL BE GIVEN TO DEMONSTRATE THE FEASIBILITY OF THE TETHER CONCEPT IN TERM OF CAPABILITY TO:

. DEPLOY

. MAINTAIN ON STATION

. RETRIEVE

THE SATELLITE FROM THE ORBITER

MISSION OBJECTIVES (CONTINUED)

FROM THE SYSTEM VERIFICATION POINT OF VIEW, TWO MAIN OBJECTIVES SHALL BE ACHIEVED:

- DEMONSTRATE THE CAPABILITY OF THE COMBINED ACTION OF THE DEPLOYER (WITH SUITABLE TETHER CONTROL LAWS) AND OF THE SATELLITE (WITH ITS THRUSTING CAPABILITY) TO CONTROL THE SATELLITE DYNAMICS DURING THE VARIOUS MISSION PHASES.
- DEMONSTRATE THE CAPABILITY OF THE SATELLITE TO WITHSTAND THE ATMOSPHERIC HEATING IN THE LOWER REGION OF THE ATMOSPHERE (130 ± 150 KM OF ALTITUDE)

SUITABLE PLANNING OF THE TWO FIRST MISSIONS AND DEDICATED ENGINEERING INSTRUMENTATION SHALL BE PROVIDED.

The first mission is planned to be an electrodynamic mission at 20 km away from the Earth. The second mission is planned to be an atmospheric mission at 100 km toward Earth, but not below 130 km in altitude. These are computed values and will be checked during the mission itself, if the temperature of the satellite has the expected behavior during this maneuver. The nominal mission duration is 36 hours. The non-operating time is 150 hours which is the time that the satellite can be in the cargo bay of the Shuttle with the door open. The minimum time for experiments is 16 hours. The satellite capability to operate with any orbiter inclination and in the range of 130-150 km of altitude will be examined.



This chart illustrates the mission phases. There is a 1-3 hour period during orbiter ascent and orbit acquisition and then a quiescent period of less than 150 hours during which the satellite is unpowered and the cargo bay are opened. Afterwards, we have a satellite checkout of 1 1/2 hours, followed by a satellite pre-deployment and full checkout period of 1 1/2 hours. Satellite deployment, stationkeeping, and retrieval comprise the next 36 hours of time, followed by a post-retrieval of 1/2 hour. The second quiescent period then occurs for a period of less than 150 hours followed by a 1-3 hour descent and landing period. The total mission duration of 36 hours can be increased if required by the scientists.



MISSION REQUIREMENTS

<p>1st MISSION</p> <ul style="list-style-type: none"> . ELECTRODYNAMIC . 20 KM AWAY FROM EARTH 	<p>2nd MISSION</p> <ul style="list-style-type: none"> . ATMOSPHERIC . 100 KM TOWARD EARTH BUT NOT BELOW 130 KM IN ALTITUDE
--	--

- . NOMINAL MISSION DURATION : 36 HOURS
- . NON-OPERATING TIME : 150 HOURS
- . MINIMUM TIME FOR EXPERIMENT : 16 HOURS
- . SATELLITE CAPABILITY TO OPERATE WITH ANY ORBITER INCLINATION AND IN THE RANGE OF 130 ÷ 330 KM ALTITUDE

MISSION DEFINITION

. THE MISSION PHASES (OPERATIVE AND NON-OPERATIVE SATELLITE) AND RELATED DURATIONS ARE PLANNED AS FOLLOWS :

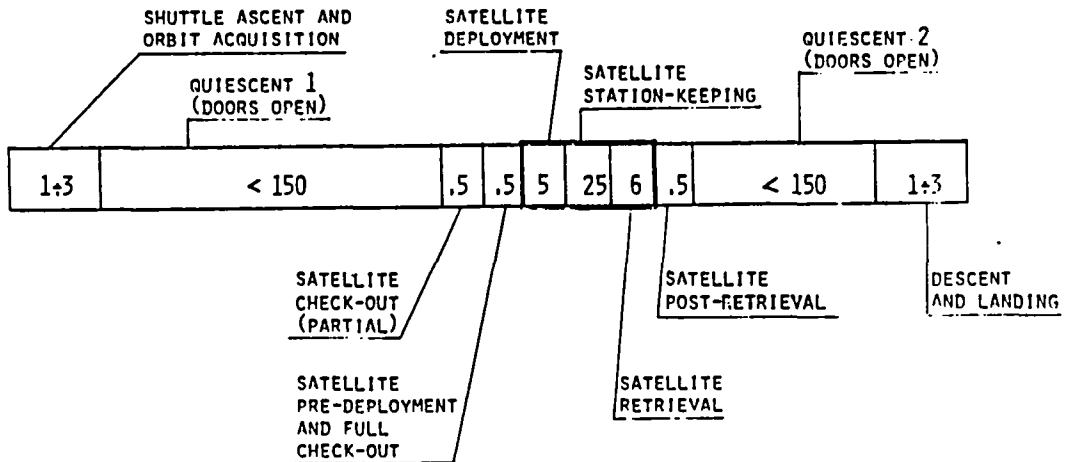

The satellite, by means of its subsystems will perform functions in support of the payload and the system operations. The following subsystems will be included: structure; thermal control; attitude measurement and control; auxiliary propulsion; telemetry, tracking, and command; on board data handling; electrical power and distribution; harness; engineering instrumentation.



The satellite configuration is a sphere with a 1.5 meter diameter. The satellite comprises two hemispheres which can be latched at the equator. The service module, attached to the tether, accommodates the electronic hardware required to support the payload. A honey-comb equatorial floor holds in position the GN₂ tank. The payload module, furnished with the annular and the two mutually orthogonal semi-circular frames, provides space for instruments location at least roughly 0.4 cubic meters.



SATELLITE FUNCTIONS AND PERFORMANCE

. THE SATELLITE, BY MEANS OF ITS SUBSYSTEMS WILL PERFORM FUNCTIONS IN SUPPORT OF BOTH THE PAYLOAD AND THE SYSTEM OPERATIONS.

. THE FOLLOWING SUBSYSTEM WILL BE INCLUDED:

- STRUCTURE
 - THERMAL CONTROL
 - ATTITUDE MEASUREMENT AND CONTROL
 - AUXILIARY PROPULSION
 - TELEMETRY, TRACKING AND COMMAND
 - ON BOARD DATA HANDLING
 - ELECTRICAL POWER AND DISTRIBUTION
 - HARNESS
 - ENGINEERING INSTRUMENTATION
-

. SATELLITE CONFIGURATION

- SPHERICAL IN SHAPE, WITH 1.5 METERS IN DIAMETER, THE TETHER SATELLITE COMPRISES TWO HEMISPHERES WHICH CAN BE LATCHED AT THE EQUATOR. _
- THE SERVICE MODULE, ATTACHED TO THE TETHER, ACCOMMODATES THE ELECTRONIC HARDWARE REQUIRED TO SUPPORT THE PAYLOAD.
- A HONEY-COMB EQUATORIAL FLOOR HOLDS IN POSITION THE CO_2 TANK.
- THE PAYLOAD MODULE, FURNISHED WITH THE ANNULAR FLOOR AND TWO MUTUALLY ORTHOGONAL SEMI-CIRCULAR FRAMES, PROVIDES SPACE FOR INSTRUMENTS INSTALLATION.

Section A-A of the tethered satellite.



Section B-B of the tethered satellite.



SECTION A-A

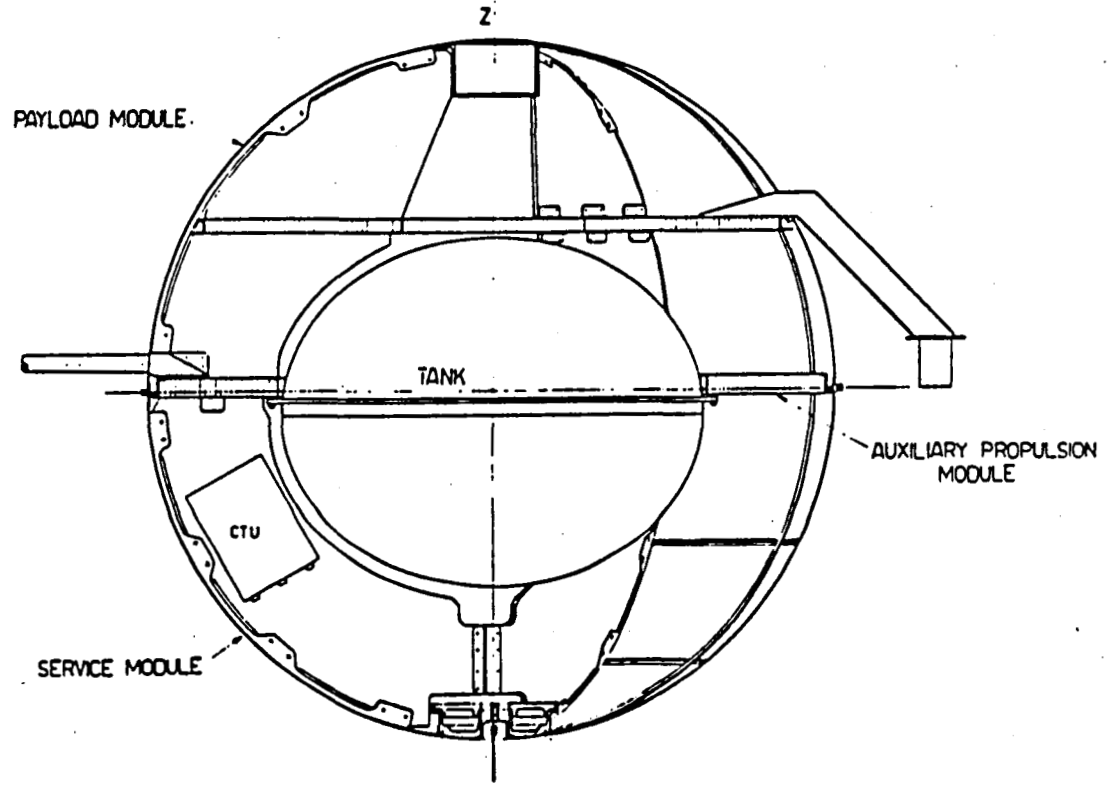

SECTION B-B

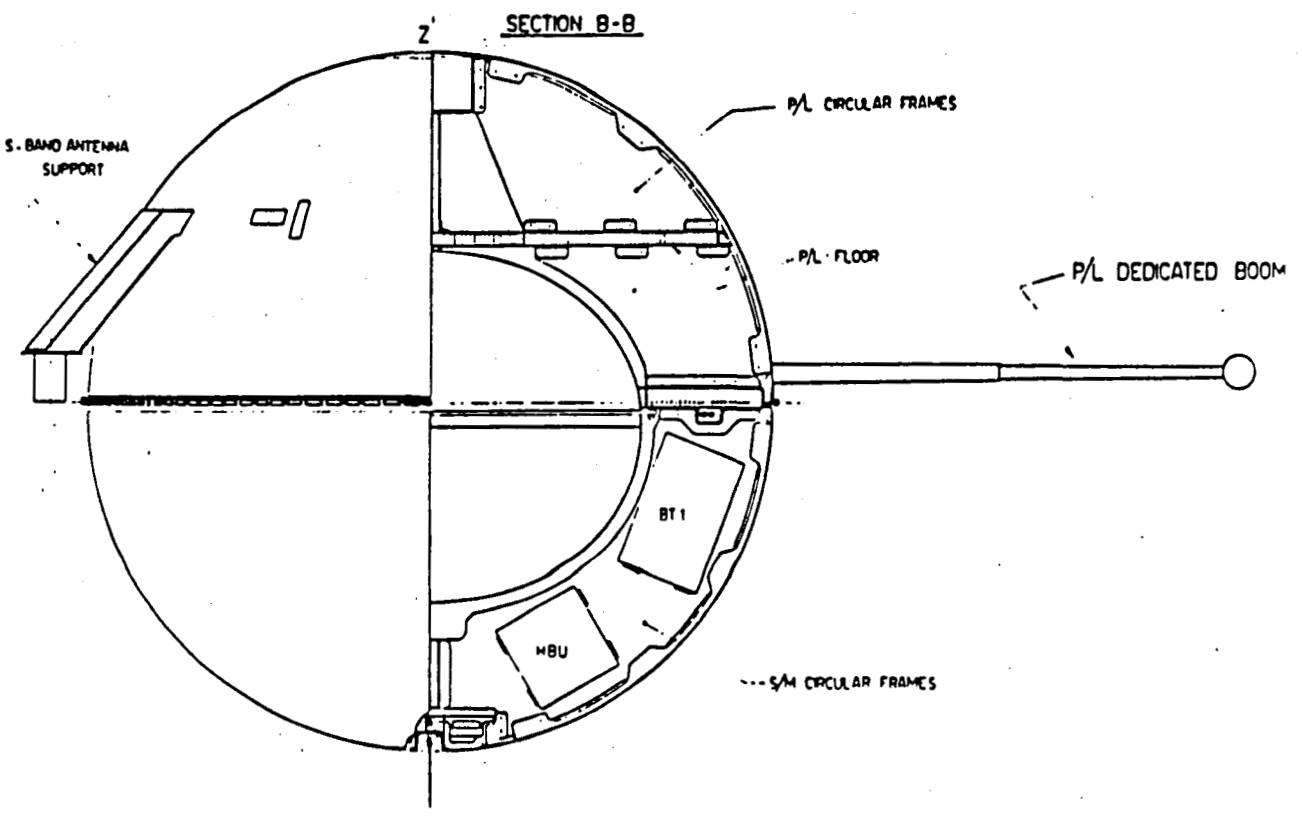

The total mass of the satellite is 500 kg. for both missions. The moment of inertia is roughly the same. The satellite shell material is aluminum alloy 20/24 E4. The surface finish is conductive for the electrodynamic mission and at least 15% surface area could be conductive for the atmospheric. We have just taken the option to consider the possibility to use the same surface finish for both missions so as to increase the conductance of the atmospheric satellite paint. The payload mass is 80 kg for the electrodynamic and only 60 kg for the atmospheric. This is mainly due to roughly 10 kg or more of gas required for the atmospheric mission retrieval. The weight of the inner sensor is required by the atmospheric scientists who require more precise data than the electrodynamic scientists. This adds roughly another 10 kg to the satellite's basic weight. The satellite external diameter is 1.5 m. The proposed paint is Goddard NS 53 B green, having surface resistivity of $1 \times 10^3 \Omega\text{m}^2$, while for ATM SAT it is Goddard NS 43 C yellow having surface resistivity of $1 \times 10^5 \Omega\text{m}^2$.



The thermal environment relative to the payload module is in general from -10 to +50 degrees. When β , the angle which the sun's rays make with the satellite orbit, equals 0 degrees the thermal environment ranges from -10 to +10 degrees; when β equals 90 degrees, the thermal environment ranges from +30 to +50 degrees. The +30 to +50 range is not expected with the currently planned orbiter.



Satellite Mechanical Capabilities

S.No	PARAMETER	TYPE	
		EDY SAT	ATM SAT
1.	SATELLITE TOTAL MASS	500 kg max.	500 kg max.
2.	MOMENT OF INERTIA	120 kg-m ²	120 kg-m ²
3.	SATELLITE SHELL MATERIAL	ALUMINIUM ALLOY	ALUMINIUM ALLOY
4.	SURFACE FINISH*	CONDUCTIVE	15% SURFACE AREA CONDUCTIVE
5.	PAYLOAD MASS	80 kg nom.	60 kg nom.
6.	SATELLITE SHAPE	SPHERICAL	SPHERICAL
7.	SATELLITE EXTERNAL DIAMETER	1.5 m	1.5 m

Notes

* Proposed paint for EDY SAT is Goddard NS 53 B green, having surface resistivity of $1 \times 10^3 \Omega \cdot m^2$, while for ATM SAT it is Goddard NS 43 C yellow having surface resistivity of $1 \times 10^5 \Omega \cdot m^2$.

Thermal Environment (Electrodynamic Mission)

NODE	Temp. °C		REMARKS
	Min.	Max.	
Payload Module	- 10 + 30	+ 10 + 50	$\theta = 0^\circ$ $\theta = 90^\circ$

* θ is the angle which the sun rays make with the satellite orbit.

The electrical facility dedicated to the payload has an average power of 50 W/16 hr with a peak power of 100 W/100 min total. The maximum energy during the mission is 900 W-h. The last science working group passed on the requirement to consider as a second option 2000 W-h of more energy at the expense of about 14 kg of payload. There is the requirement to consider this as a baseline mission so that the baseline is 2000 W-h and 66 kg of payload. As an alternative 900 W-h can be used with 80 kg of payload. There are limits in both average and peak power. The second requirement means that the scientists are looking at longer duration than planned mission. The voltage is supplied regulated at 28 ± 4 VDC.



The telemetry acquisition of payload data uses 64 channels (Analog, Discrete, 8-16 Bit Serial) with a bit rate of 6 KB/sec during deployment and retrieval because of the use of a lot of telemetry that is not in any way limited to 16 KB/sec by the shuttle payload interrogator during retrieval. This telemetry is used to control the satellite. During stationkeeping, 12 KB/sec are allocated to the payload. There is an event datation of 16 bit words between 8 μ s and 1 ms resolution, a synchronization signal between 2 and 32 μ s intervals, and a 16 bit word master time distribution. For the telecommand distribution, there is a 64 channel telecommand that can go to instruments. The command bit rate is .5 KB/sec during deployment and retrieval and 1.5 KB/sec during stationkeeping.



PAYLOAD DEDICATED ELECTRICAL FACILITIES

PARAMETER	VALUE
AVERAGE POWER	50 WATTS/16 HRS
PEAK POWER	100 WATTS/100 Mins.
MAXIMUM ENERGY	900 WATT-HRS (2000 WATT-HRS FOR LONGER DURATION AT THE EXPENSE OF ABOUT 14 KG OF PAYLOAD)
VOLTAGE	28 ± 4 VDC

Electrical Facilities

TELEMETRY ACQUISITION OF PAYLOAD DATA	
No. of Channels	64 (Analog. Discrete, 8-16 Bit Serial)
Bit Rate	6 KB/sec during deployment and retrieval 12 KB/sec during station keeping
Event datation	16 bit word 8 μs - 1 ms resolution
Sync. Signal	2 - 32 μs Interval
Master Time Distribution	16 bit word
Telecommand Distribution	
No. of Channels	64
Command Bit rate	0.5 KB/s Deployment & Retrieval phases 1.5 KB/s Station keeping Phase

This chart outlines the Satellite Position Determination Accuracies at the nominal condition of 20 km above the orbiter for the electrodynamic mission and 100 km below for the atmospheric. We expect to have an Orbiter-Satellite Altitude Accuracy of $\pm 120\text{m}$ for the electrodynamic mission and $\pm 400\text{m}$ for the atmospheric mission. This figure is based on Ku-band radar accuracy of the Shuttle radar. The Orbiter-to-Satellite Line of Sight Angle Accuracy is $\pm 2.5^\circ$. The satellite altitude accuracy and satellite planar accuracy are peculiar figures to be determined by Martin Marietta.



This chart outlines the expected parameters for Altitude Control and Measurement Accuracy.



Satellite Position Determination Accuracies (3σ)

S.NO.	PARAMETER	MISSION	
		EDY	ATM
1.	Satellite altitude above Orbiter	20 Km	100 Km
2.	Orbiter-Satellite Altitude Accuracy* (Ku-band radar accuracy)	±120 m	±400 m
3.	Orbiter-to-Satellite LOS Angle accuracy**	±2.5°	±2.5°
4.	Satellite altitude accuracy	TBD	TBD
5.	Satellite Planar accuracy	TBD	TBD

- * Ku-band radar used in Passive mode for EDY SAT and active mode for ATM SAT. Quoted accuracies are Sum of Random and Bias errors.
- ** LOS angle is Ku-band radar angle both for in-plane and out-of-plane angles.

ATTITUDE CONTROL & MEASUREMENT ACCURACY

S.NO.	PARAMETER	MISSION	
		EDY (20Km)	ATM (100Km)
1.	Tether in-plane angle range*	± 0.5°	1.5° Bias ± 1° (Polar orbit)
2.	Tether out-of-plane angle range *	± 0.1°	±0.2°
3.	Satellite Pitch angle range**	± 2°	±2° to -4°
4.	" Roll " "	± 2°	± 1°
5.	" Yaw " "	N.A.	±5.5° (Polar orbit)
6.	" Slide Slip " "	N.A.	± 2°
7.	" Pitch angle accuracy***	± 1°	± 0.3°
8.	" Roll " "	± 1°	± 0.3°
9.	" Yaw " "	± 1°	± 0.3°

- * TETHER PITCH & ROLL ANGLES RANGE CONTROL IS SYSTEM RESPONSIBILITY.
- ** THESE FIGURES, OBTAINED VIA AERITALIA SIMULATIONS NEGLECT TETHER CONTROL LAW ERRORS, AND TAKE INTO ACCOUNT POSSIBLE C. OF G.ERRORS, THRUSTERS MISALIGNMENT AND TETHER INERTIA EFFECTS.
- *** ATTITUDE ANGLES ARE MEASURED BY RATE INTEGRATING GYROS (RIG) AND ARE PERIODICALLY UP DATED BY FOUR TWO-CHANNEL SUN SENSORS.

This chart summarizes the Attitude Oscillation Characteristics for the electrodynamic and atmospheric missions.



ATTITUDE OSCILLATION CHARACTERISTICS

S.No	PARAMETER	EDY (20 km)	ATM (100 km)
1.	Tether in-plane oscillation period	3080 sec.	3080 sec. (Equatorial) 2667 sec. (Polar)
2.	Tether out-of-plane	2667 sec.	2667 sec. (Equatorial) 5334 sec. (Polar)
3.	Satellite Pitch Period	5+10/3080 sec.	5+10 sec. & Tether oscillation
4.	Satellite Roll Period	5+10/2667 sec.	5+10 sec. & Tether oscillation
5.	Satellite Yaw Period	N.A. (1 RPM \pm 10%)	120+220 sec. (and 5334 sec., in Polar Orbit)

SESSION III
FUNDAMENTALS AND APPLICATIONS

TETHER FUNDAMENTALS

Charles Rupp
Marshall Space Flight Center

The forces that are on each of the tethered bodies in the tethered satellite system are shown here in this chart.



When the system rotates, the position of the center of gravity is not going to be at uniform altitude and additional work needs to be done in really defining that motion. It's going to be some sort of elliptical or scalloped shape trajectory.



FORCES ON TETHERED SATELLITES

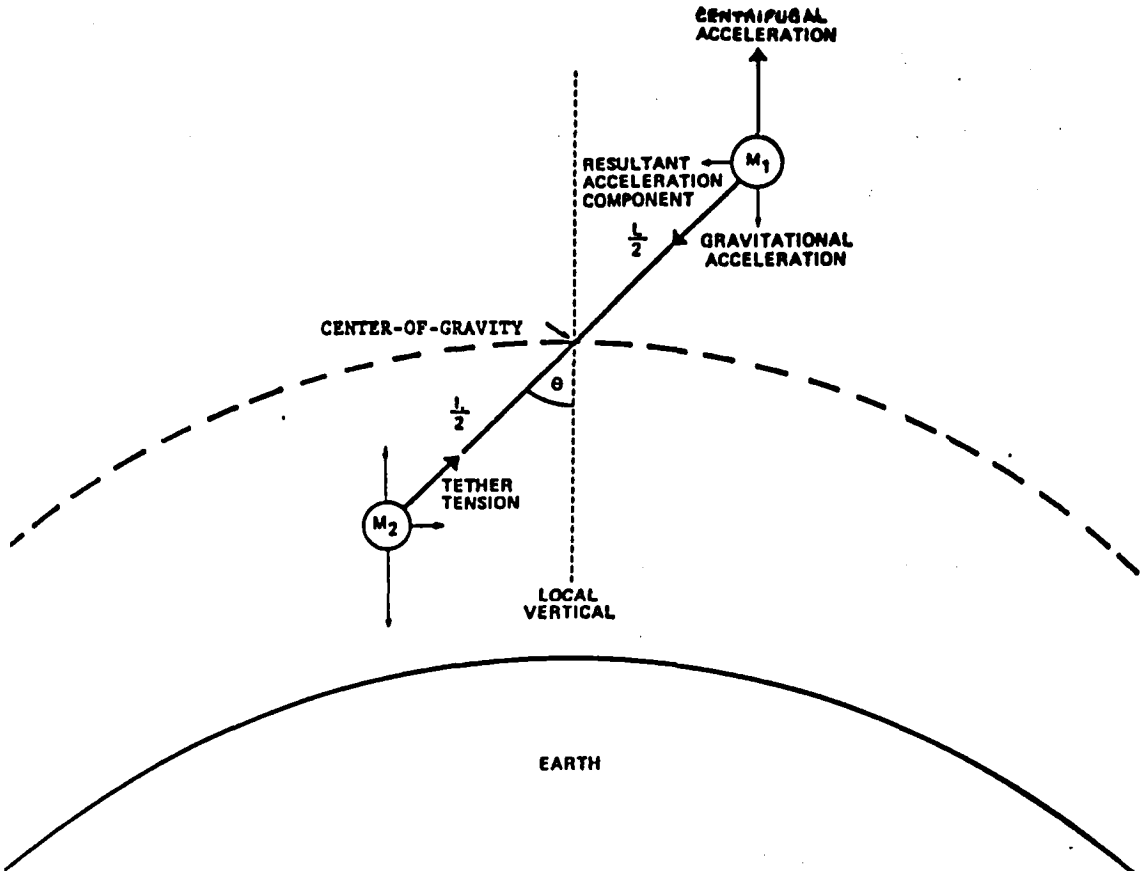
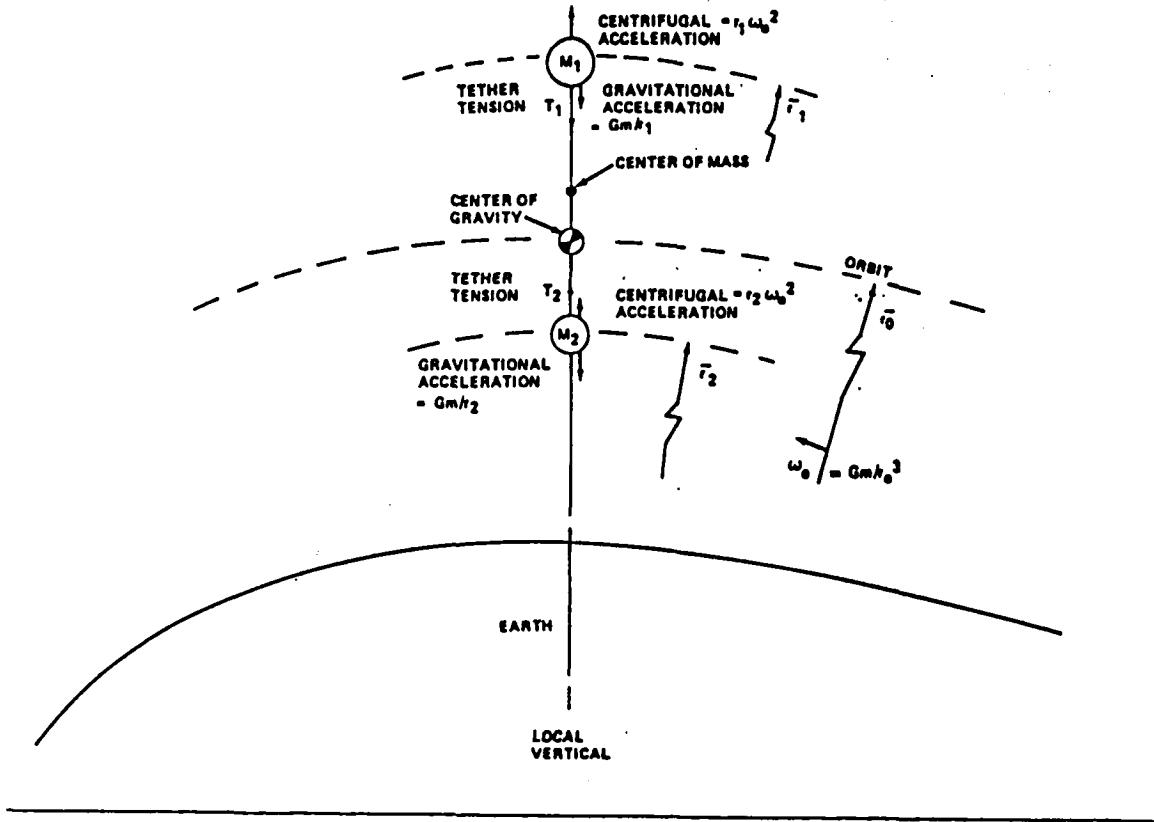

This chart plots tether tension as a function of the effective mass and the distance to which the satellite is deployed.



This chart shows some of the materials that have been considered for the use in tethered satellite systems. Early in the Phase A study the stainless steel wires were considered as the one alternative. The steel wires though suffer from being fairly stiff. Kevlar turns out to be a fairly good candidate from the viewpoint that it has a very high strength to weight characteristic and its roughly seven times stronger than steel for a given mass of tether.



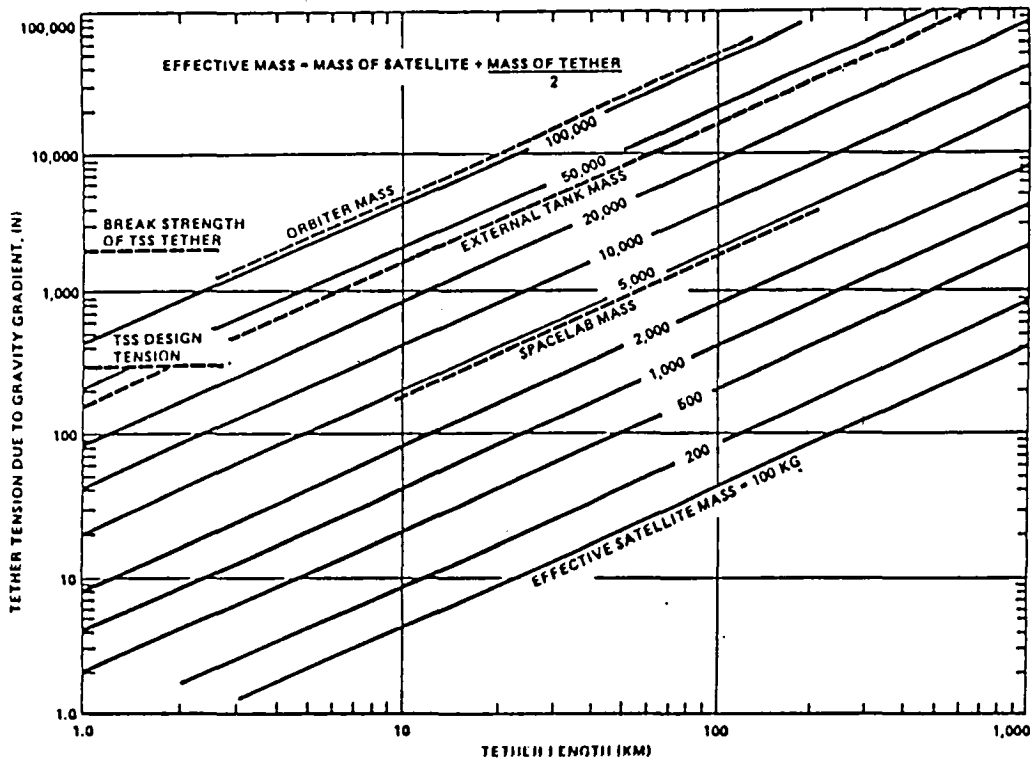

TETHER TENSION TO GRAVITY GRADIENT VERSUS TETHER LENGTH
FROM CENTER OF GRAVITY AND EFFECTIVE SATELLITE MASS

Candidate Tether Material Parameters

	Kevlar 29	Kevlar 49	Dacron T68	Nylon T-128	Rayon Viscose	Steel Wire	Glass E	Glass S	Graphite HT
Density g/cc	1.44	1.45	1.38	1.14	1.52	7.74	2.55	2.50	1.50
lb/in ³	0.052	0.052	0.050	0.061	0.055	0.280	0.092	0.09	0.054
Denier/Filaments	1500/1000	380/258	1300/1000	1260/840	Staple	Fil.	Fil.	Fil.	Fil.
Tensile Strength psi x 10 ³	500 (400)	525 (400)	105 (80)	117 (70)	70 (35)	600 (500)	500 (350)	650 (500)	500 (350)
MN/M ²	3.450	3.620	550	480	240	4.140	3.440	4.480	3.440
GPD (tenacity)	20-22	22.4	4.5 (8)	5 (8)	2 (4)	3.9	9.6	12	16
Tensile Modulus psi x 10 ⁶	9.1	19	1.5	0.7	0.4	30	10.5	12.6	35
MN/M ² x 10 ³	63	131	10	5	3	208	72	87	240
GPD (stiffness)	480	1004	21	18 (48)	11	—	—	—	—
Elongation %	3.6	2.75 (2.4)	15	19	17	1.1 (10)	3.1	3.	1.9
Dielectric Constant	3.4	3.4	4	4	4	—	4.5	4.5	5
Loss Tangent	0.005	0.005	.01	.01	.01	—	.01	.014	2.5
Specific T.S. (in) ¹⁰	10 (8)	10 (8)	2	1.8	1.3	2.1	5.4	7.2	9.3
Melt Point °F.	800°F chars 450°C	800°F chars 450°C	482 250°C	482 250°C	chars	2550°F 1400°C	1290°F 700°C	1540°F 840°C	6600°F 3650°C
Specific Modulus (in)	1.75	3.6	.3	.11	.07	1.1	1.2	1.4	6.5

(a) Nominal properties (Note): This table oversimplifies the properties with the use of single number filament properties. All have ranges of strengths, densities and statistical distributions of all properties. They are commercially available materials but yarn and composite properties will tend to be lower ((in parenthesis)).

The next chart states the control law that was looked into at Marshall in the Phase A study.



This chart describes tethered satellite deployment and retrieval.



STABILIZATION CONTROL LAW

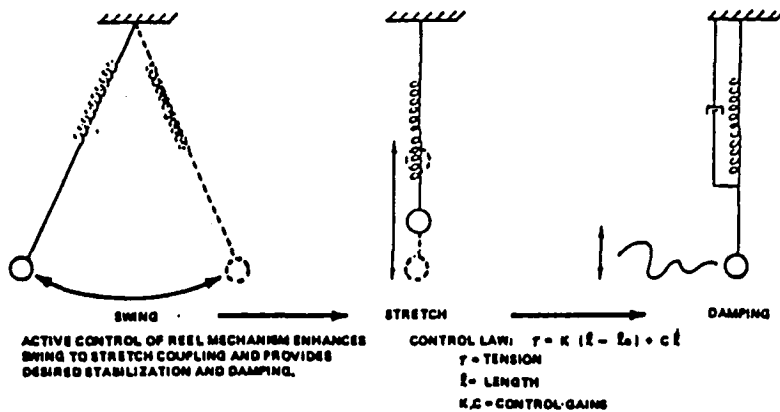

TETHERED SATELLITE DEPLOYMENT AND RETRIEVAL

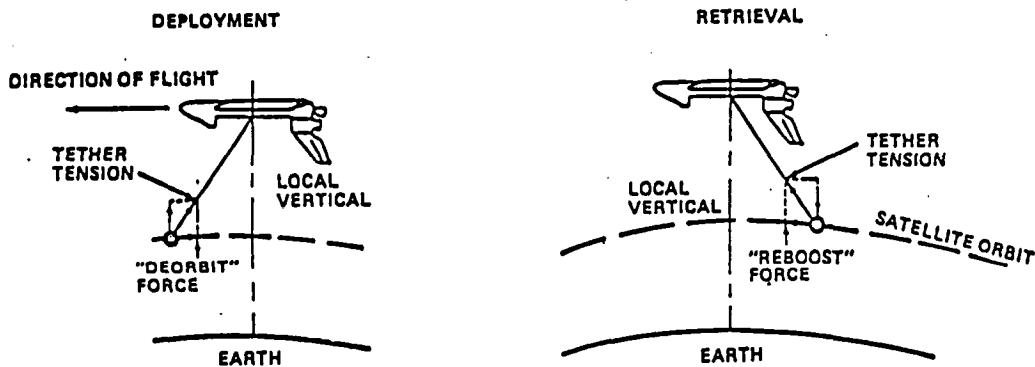

A tethered satellite system can have a great deal of angular momentum when you look at the rotation of the system about its center of gravity as it goes around in orbit and initially before the system is deployed if you consider the two bodies to be point masses.



This chart addresses the momentum issue which involves making use of the electric motor effect to boost the orbit of the tethered system.



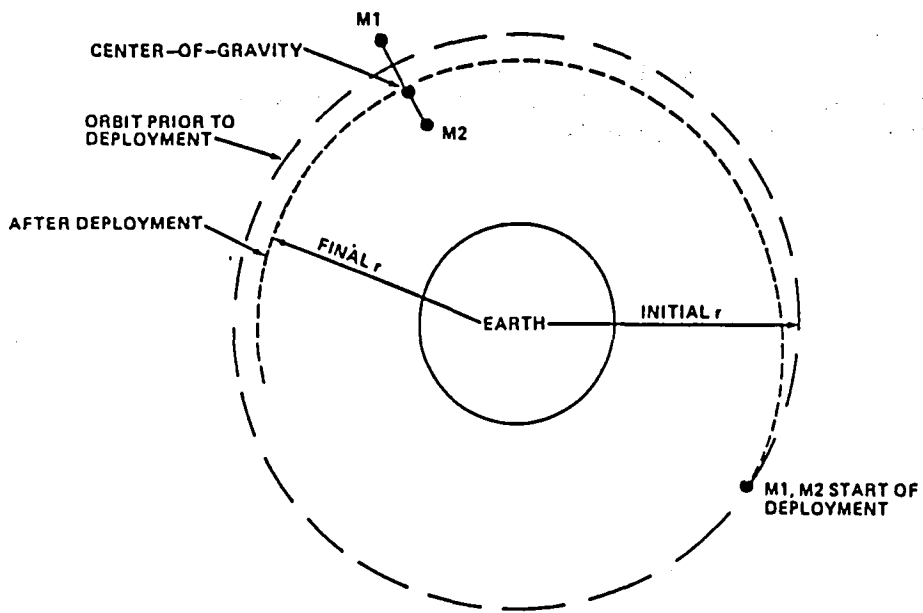

WHERE DID THE ANGULAR MOMENTUM COME FROM

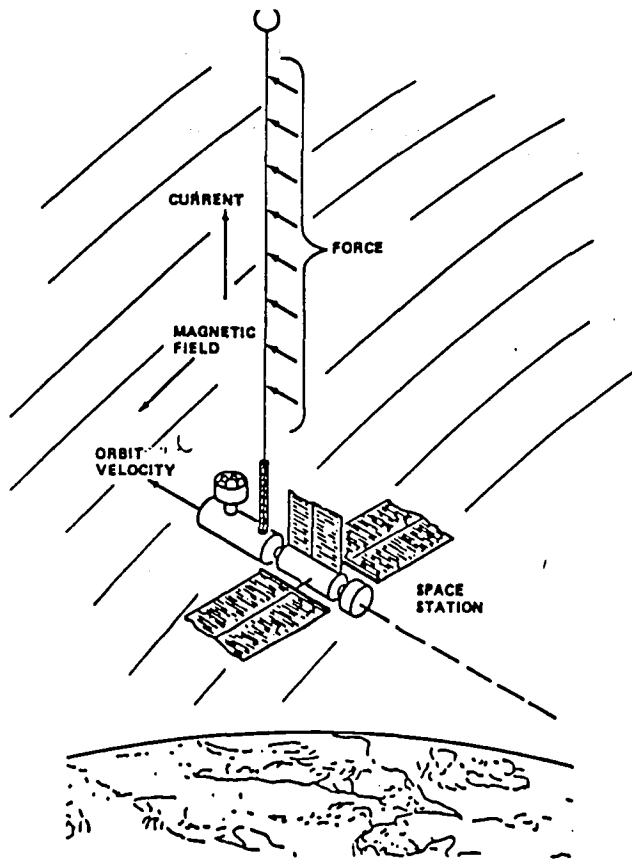

"ELECTRIC MOTOR EFFECT REBOOST"

This chart illustrates a phenomena described in a Smithsonian report. This is a report that Smithsonian did on the tether launcher work and it describes an interesting condition. For long tethers it is impossible to have a situation where as you retrieve the tether system, i.e., bring the two bodies together, the lower body can appear to be rising just up to the altitude of the higher body or likewise as you deploy, the altitude of the higher body can remain stationary.



This chart shows the tethered system acts on the orbiter center of gravity.



A VERY LONG TETHER PHENOMENON

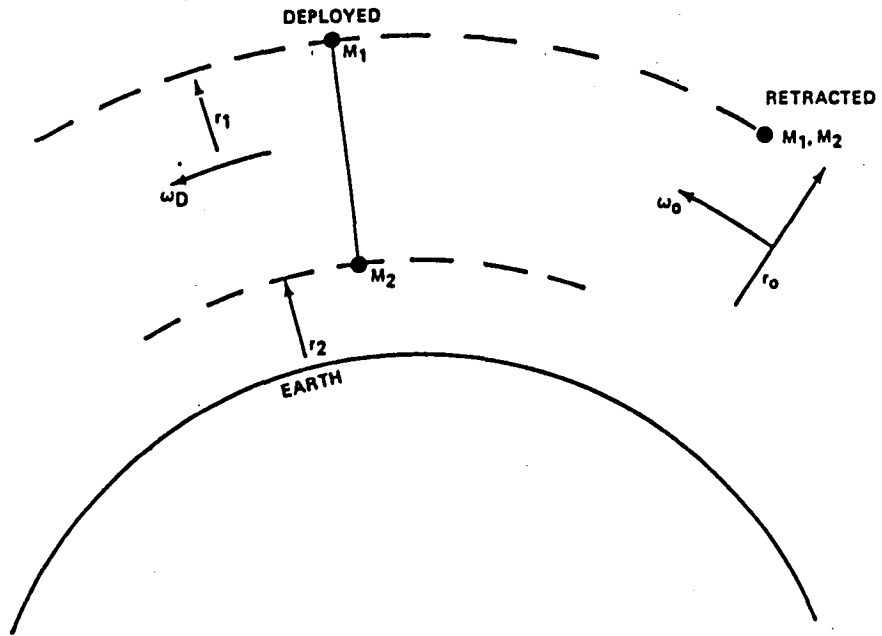

SHUTTLE TETHERED SATELLITE EFFECTS ON THE ORBITER

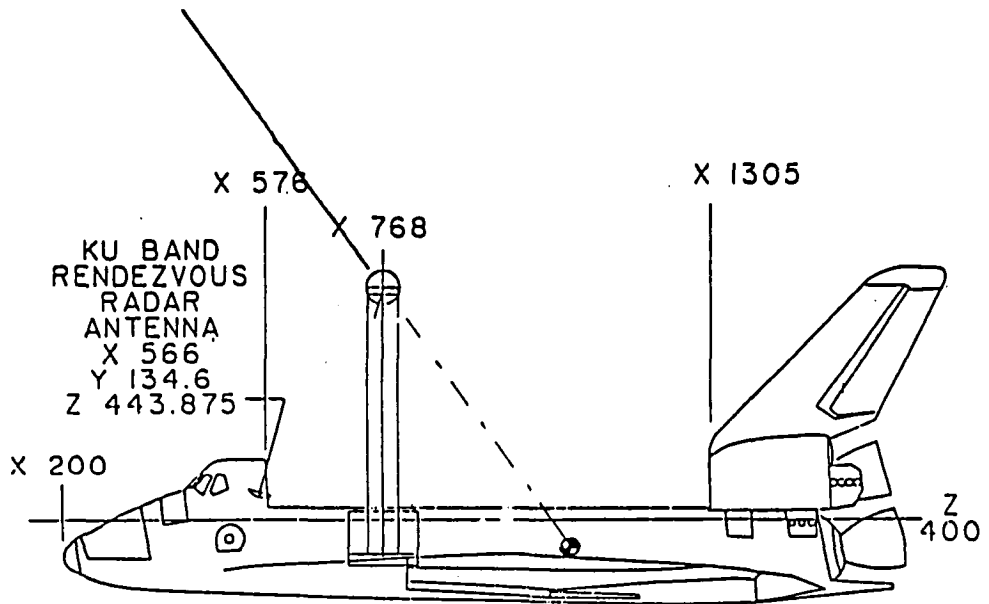

Plotted on this graph is the acceleration that is experienced at the end of a tether. This tether length is measured from the CG to the satellite. Very large accelerations require very long tethers. For the first early missions when using some of the more common kinds of tethers it is expected to have tethers roughly in this range. One has to go to the taper tether to get to the further longer deploying ranges. It is expected that there will be some science payloads that could take advantage of the even small amount of gravity associated with the short deployment.



This chart describes what might be the most critical problem associated with the tether launchers. The velocity of attempting to pick up a payload or snatch a payload from an orbiter that is coming up to a lower end of a tether launcher system. This is the relative velocity that a tethered satellite has with respect to a free flying satellite flying at the same altitude as the satellite at the end of a tether.



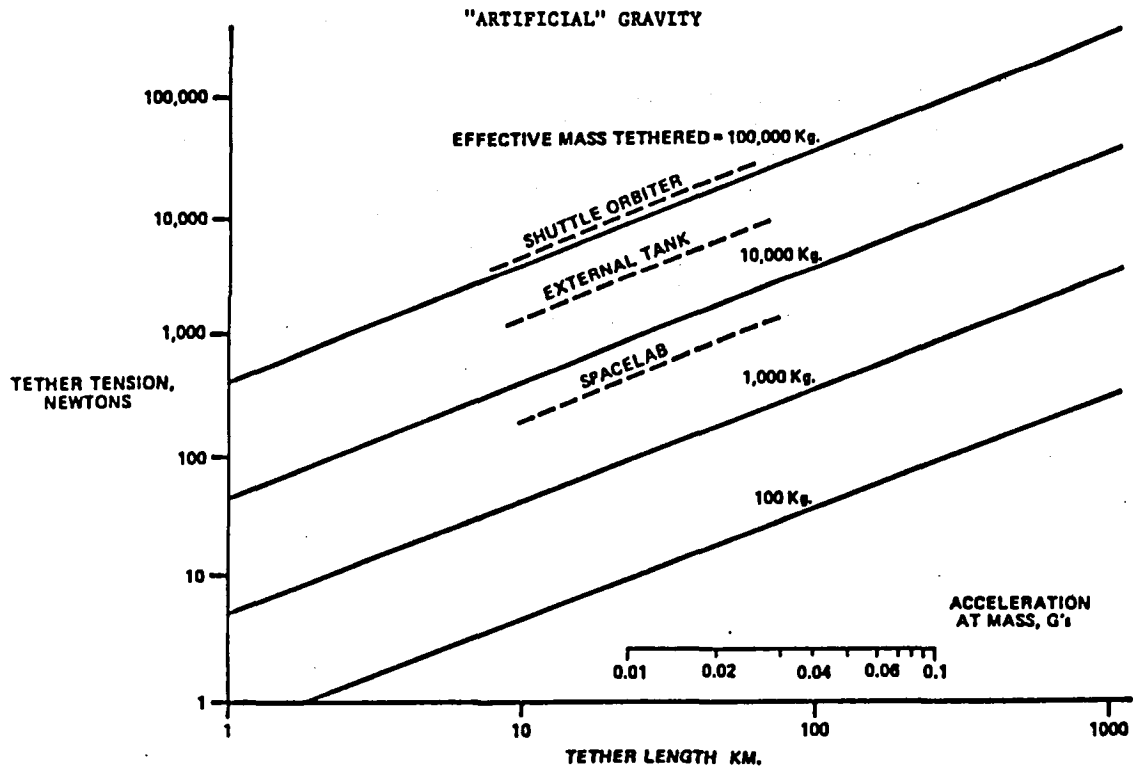

**TETHERED SATELLITE RENDEZVOUS AND DOCKING
RELATIVE VELOCITY**

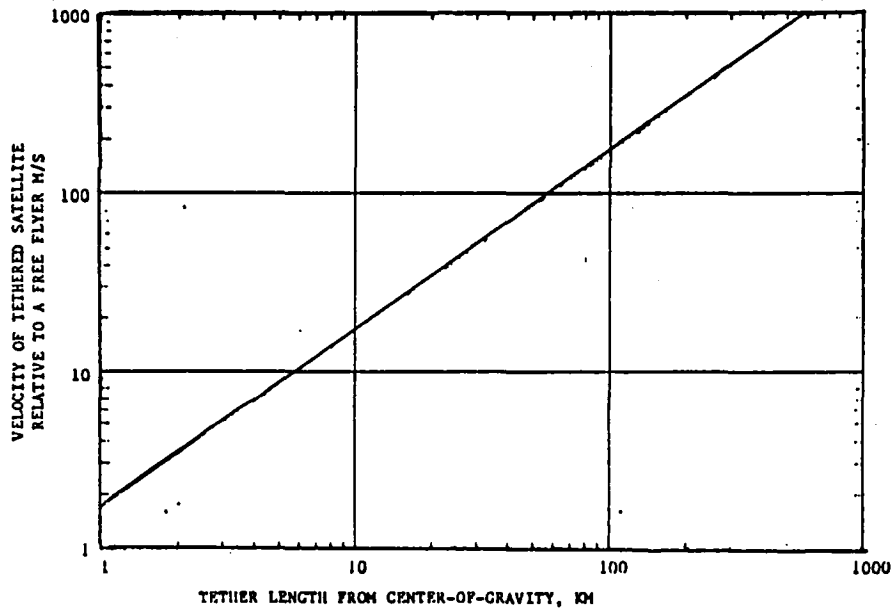

Shown here on the right is a characteristic of how much reel diameter is required to store given sizes of tether starting with drum diameters of 6" on out to 38". What the tether satellite system reel can contain and the tether length stored on the reel is shown. Also shown is a mass summary which breaks down the mass of the tethered satellite system into various elements. If one had an application having ten times the tether mass associated with it, one could possibly extrapolate upward from the 220 to 2,200 kg and multiply the tether support by a factor of ten and keeping the satellite support electronics the same get a handle on what the total subsystem or total system masses would be.



Where is the limit on our extrapolation of the designs to these future applications? The tether properties themselves will be the limit on most of the applications, finding the high strength, high temperature, high specific strength tether materials. Another issue associated with the strength requirement is what factor of safety should be used in the design? If it is a single strand, one would want to use a fairly high factor of safety which greatly affects the overall mass required in the tether system. If one is more clever, he might have multiple strands which can give redundancy and thus decrease the factor of safety one would want to have in the system and effect a more realistic design. System limitations are those kinds of limitations dealing with the end effector, and the terminal rendezvous and docking issue associated with launchers. The cost benefit trade is also of interest.



SCALING UP FROM THE SHUTTLE/TETHERED SATELLITE SYSTEM

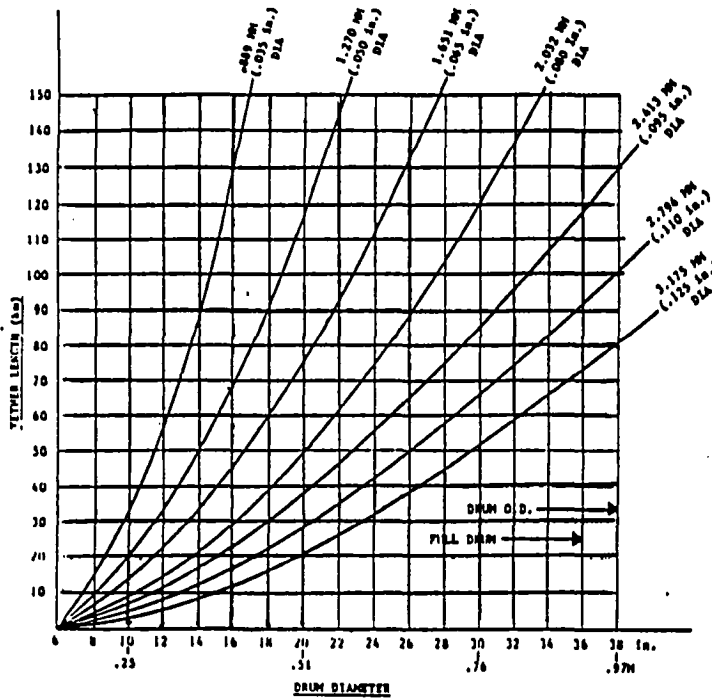

Tether Reel Capacity Vs Tether Diameter

TSS MASS SUMMARY (kg)

TETHER SUPPORT	784
TETHER	220
SATELLITE SPT	397
ELECTRONICS	75
SATELLITE	500
	<u>1976</u>

REEL SIZE

REEL LENGTH = 1.22 m
SPOOL DIAMETER = 0.152 m

TETHER CHARACTERISTICS

MATERIAL ARAMID
DIAMETER 1.6 mm
MASS 2kg/km
STRENGTH 2000 N
DERATE FOR LONG EXPOSURE
OR ELEVATED TEMPERATURE

WHERE IS THE LIMIT?

- TETHER PROPERTY LIMITATION
- SYSTEM LIMITATIONS
- COST/BENEFITS TRADES

SCIENCE APPLICATIONS I

Franco Mariani
University of Rome

SCIENCE BY TETHERED SATELLITES

Introduction

It is now sufficiently clear that tethers will play an important role on either technological or scientific progress of space science. After all, this is the real meaning of our presence here for our three-day workshop. In this short presentation, acknowledgment is given to previous documents where science by tethers has been suggested since the early ideas by Isaac et al. (1966) and the report by Colombo et al. (1974). Since then careful technical studies and wide scientific discussions have shown the feasibility of the project and confirmed its scientific interest to the point that we have now just reached the phase of soliciting scientific proposals from the worldwide community for the first two missions, which are indeed demonstration flights but also have a large scientific potential.

We shall give an overview on the science by tethered satellites, in particular for the first two missions, also the model payloads considered in the feasibility study for an electrodynamic and an atmospheric mission.

The Main Scientific Objectives

Scientific goals will be achieved in two correlated general fields: one has to do with the physics of the atmosphere, the ionosphere, and the magnetosphere; the other with the physics of plasmas in space. Actually the two fields primarily overlap with each other; however, we shall consider them separately for practical purpose.

Atmosphere, Ionosphere, and Magnetosphere. The neutral and ionized gaseous environment and its expansion toward the interplanetary medium, in the presence of the terrestrial magnetic field constitute a complex system whose understanding has made enormous progress in the last quarter of century. However, many basic questions on the global processes taking place inside the system are still unanswered, in particular those taking place in the range of altitudes below 200 km down to 80-120 km. It is just this last altitude where the atmosphere progressively ceases to be mixed by the turbulence, as typical of all the lower atmosphere. Above it molecular diffusion becomes predominant (i.e., atmospheric constituents begin to separate from each other) and atomic oxygen becomes an important constituent. At this altitude the mean free path of the atmospheric gas is comparable with a typical satellite size. Very little scientific data have been collected below 200 km altitude, by rockets and by some satellites (AE, Atmospheric Explorer, and DE, Dynamic Explorer) whose orbits were selected with a perigee low enough to spend a few minutes/orbit down to 150 km (AE) and also somewhat lower (DE). It is then obvious that the temporal and geographic coverage is absolutely inadequate compared to what is really needed to the physical understanding of the basic structure and processes occurring below 200 km.

So, the TSS is the only simple, and relatively inexpensive tool to keep a scientific payload on a very low altitude orbit as long as many days. One of the principal objectives is the determination of the chemical composition of the upper atmosphere, just in the region where the vertical transport processes are important for the exchange of hydrogen (upward) and of nitrogen compounds (downward). The presence of atomic and molecular hydrogen (H, H₂), atomic oxygen (O), and nitrogen (N₂), as well as traces of minor components (for example sulphur, S) gives rise to a large number of chemical constituents, which may have extremely different lifetimes. So any atmospheric model badly needs in situ mass spectrometric measurements to determine actual compositions, as well as the vertical distributions and temporal variations.

A number of active experiments can also be devised to understand most basic questions on the dynamical processes by means of chemical releases. Chemical tracers can be seeded inside large volumes and areas to study the complex neutral atmospheric circulation pattern.

Above 100 km altitude the atmospheric constituents are subject to the ionizing action of the ultraviolet solar radiation. As a consequence of the energy deposition, heating occurs and the temperature of the gas increases with the altitude: electrons, positive ions, and neutrals show different vertical profiles of temperature, because of the decreasing thermal exchange. At these altitudes a fast transition occurs between a regime of high collisional rate between neutrals and ions and one of rapidly vanishing rate. As a consequence, at lower altitudes the ions are carried along by neutral winds, while a few tens km above electric field drift motions dominate the ion motions. Global motions of the ionized components embedded in the neutral gas and in the presence of the geomagnetic field give rise to an electrical current system (the so called dynamo currents), which is the source of the ground geomagnetic variation either regular (i.e., diurnal) or irregular, as well as of Joule heating. These currents which are essentially ionospheric at low and middle latitudes are only one aspect of a general pattern of current circulation, which takes a very complex configuration at higher latitudes. Here, due to the high conductivity, nearly vertical geomagnetic field lines become electric ducts driving field aligned currents, called Birkeland currents, up to the magnetospheric regions, where the impinging solar wind delivers energy to the magnetosphere. Additional features occur, again at high latitudes in the polar caps, where direct bombardment of high energy protons frequently occurs.

Seeding of appropriate tracers can also be used to modify in some way the electrical conductivity of the ionosphere and then the circulation of electric currents in the ionosphere-magnetosphere system, so helping to clarify the nature and behavior of the magnetospheric dynamo.

Another challenging scientific objective is a more accurate determination of the electric field distribution in the very low atmosphere. At low altitudes close to the Earth's surface, thunderstorms are generally assumed to be the generators of an atmospheric vertical current flow; at the upper end, the boundary conditions may be determined by in situ measurements, so that reliable models of the global atmospheric

electricity distribution can be worked out once the conductivity vertical distribution is known (or at least estimated). Good knowledge of the entire circulation system is also required to clarify the solar weather relationship. In summary, the TSS mission will allow direct observation of the structure and the dynamics of the lower atmosphere; basic questions will be answered, some of them being: what the chemical composition of the atmosphere; what the coupling mechanisms between small and large scale motions; what the global wind field of the lower atmosphere, and how it is influenced by waves and tides; what are the mass, momentum, and energy fluxes in the lower thermosphere; how all above are affected by externally perturbed conditions (for example by magnetic storms, solar wind and its variability, etc.); what is the pattern of electric current circulation and its relationship with the magnetospheric environment.

A sketch of the concurrent atmospheric-ionospheric physical processes is given in Fig. 1, while some more specific facts are illustrated in Figs. 2 and 3.

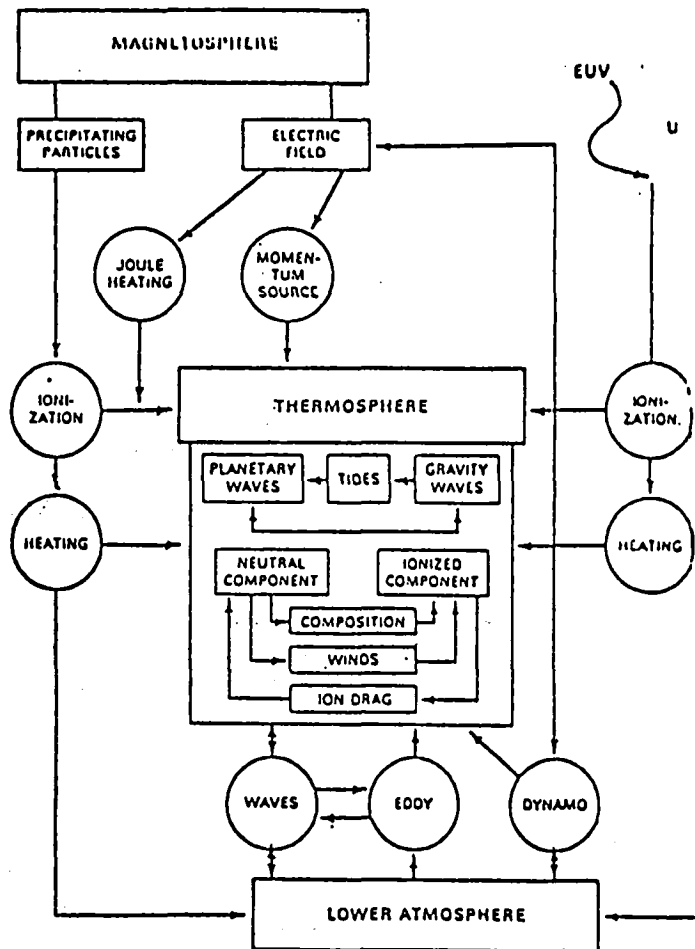

Figure 1.
Schematic Diagram
Illustrating the
Important Processes
Linking the Lower
Atmosphere, Thermosphere,
and Magnetosphere.
Within the thermosphere
a variety of waveforms
are generated ranging
from planetary scale
to gravity waves.

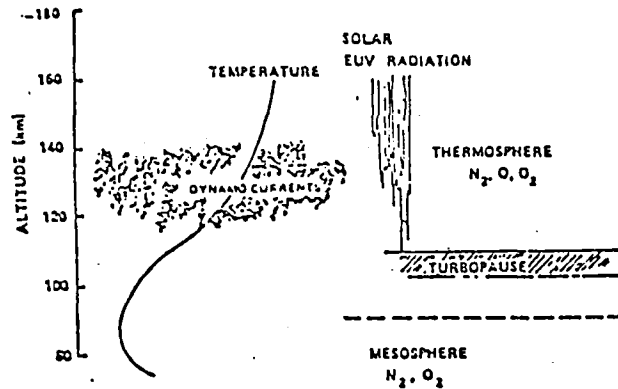

Figure 2. Upper Atmosphere Regions Showing Schematically the Transition from the Mesosphere to Lower Thermosphere, the Turbopause and the Zone Where Dynamo Currents are Present

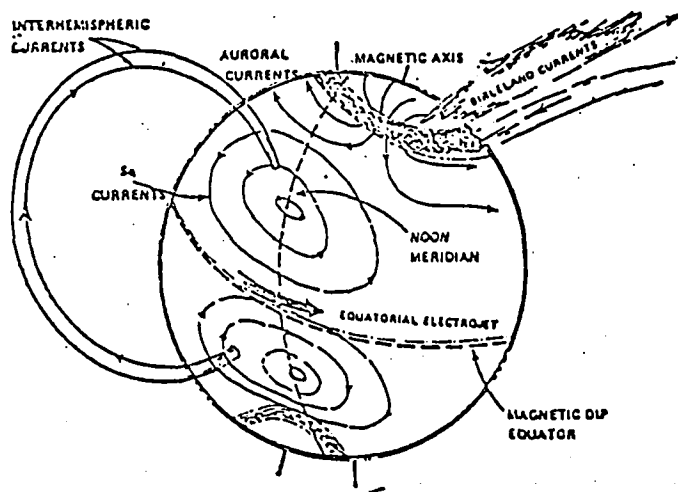

Figure 3. Schematic View of the Global System of Upper Atmospheric Currents Including Wind-Driven Currents at Mid-Latitudes, High Latitude Auroral Currents, and Inter-Hemispheric Field-Aligned Currents

Figure 1 summarizes the very complex intercorrelated mechanisms at work in the lower atmosphere, the ionosphere, and the magnetosphere. Figure 2 shows the physical situation of the atmospheric region where transition from the mesosphere to the thermosphere occurs: the incoming UV solar radiation is the main source of ionization and energy, and because of the high electric conductivity electric currents are generated by even very small induced electric fields. Figure 3 shows an idealized sketch of the global electric currents system where the diurnal system

(responsible of the geomagnetic diurnal variation) is shown, including the equatorial and the polar electrojets as well as the field aligned currents at middle latitudes and in the polar caps. The atmospheric downward TSS mission will also allow systematic in situ measurements of the geomagnetic field distribution in the lower atmosphere, which, in addition to being a very sensitive parameter to detect the characteristics of the current system, is also very interesting to improve our knowledge of the geomagnetic field gradient, and thus of the low scale internal source. A good improvement of higher order harmonics, i.e., of small scale features, will also be possible for the gravity field by means of gravity gradiometers. Simultaneous measurements of electric field, neutral winds, chemical composition and density will constitute a unique tool to understand the coupling between lower and upper atmosphere. The possibility of simultaneous sampling at different altitudes (as possible in more advanced missions) will allow the necessary tridimensional access to the full system, just in the region where most of the dynamics occur.

Space Plasma Physics. Here a different type of physical problems can be attached because of the fact that the TSS can be used to perform unique active experiments in the terrestrial plasma environment, in ways previously impossible, which will also be of big help in understanding the physical behavior of other planetary and interplanetary plasma environments, as well as in astrophysics.

The basic idea is that an induced electric field $E = v \times B$ is generated inside a conductive tether in motion with velocity v in the ionized ambient permeated by the geomagnetic field B . The satellite, upwards, becomes positively charged so attracting electrons from the surrounding plasma; conversely, the Shuttle, negatively charged, attracts positive ions. As a consequence, an electric current flows along the tether.

The concept of electrodynamic tether is illustrated in Fig. 4. If the tether is electrically insulated there is no possibility of discharging into the ionosphere, so electrons entering the satellite surface can only be emitted by the Orbiter. With a tether length of several tens km a potential difference of several thousands volts develops.

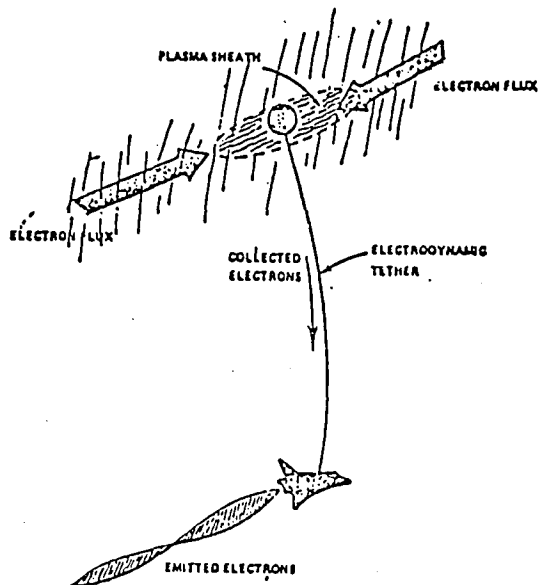

Figure 4.
Basic Components of Electrodynamic Experiments with the Tethered Satellite System. The conducting tether is insulated along its length from the ionospheric plasma so electrons can enter or leave the system only at the satellite and the Orbiter. Active electron emission occurs at the Orbiter, while electron collection takes place at the electrodynamic satellite.

The actual potential of the Shuttle and the satellite with respect to the surrounding plasma strongly depend upon the size of the two bodies, or, better, the size of their conducting surfaces. If the satellite is big so to collect a large flow of electrons from the environment there is a tendency for the satellite to have a low potential while the Shuttle takes a high negative potential. Safety reasons require an electron gun to emit sufficiently high electron flow to lower the potential to acceptable low values. In this way most of the potential drops ohmically along the tether. Model calculation of the current intensity along the tether show it may typically be as high as several amperes.

All above implies that a high priority objective of an electrodynamic mission is the determination of the electric potential distribution around the satellite, to understand clearly its interaction with the plasma in a variety of situations.

In general, either active or passive experiments can be envisaged, i.e., with or without electron guns. Waves can be generated, spontaneously or driven, in a wide bandwidth. Actually, the satellite and the Shuttle at any given time perturb the plasma in two regions located on different ambient field lines. Due to the rapid motion of the system in the ionospheric magnetoplasma and the high conductivity of this plasma along the magnetic field lines the two regions where excess of positive or negative charge is generated tend to rapidly extend themselves along the instantaneous field lines. Two thin sheets are thus produced, the so called Alfvén wings (Fig. 5) which propagate at Alfvén velocity (of the order of 200 km/sec) toward the lower ionospheric region, the E region, where the transverse conductivity becomes high enough so that charge neutralization finally occurs (Fig. 6). It is a very remarkable fact that the current intensity along the conducting tether can be widely changed, to get constant or time-modulated values. This can be easily obtained by varying an impedance connected in series with the conducting tether or by using an electron gun on the lower body. A large variety of different physical situations can thus be explored: in particular large amplitude VLF waves generation. VLF waves can also be generated as a consequence of instabilities produced in the ambient plasma by the field aligned currents or by particle stream acceleration due to the high electric potentials associated with the system. Other examples are the possibility of studying the propagation of low frequency waves and whistlers between opposite hemisphere; the excitation of a wide spectrum of electrostatic and electromagnetic waves by the field aligned currents in a very wide range of geometrical and physical parameters (angle to the field line, frequency amplitude, ambient ions velocity distribution, linear and also non-linear regimes). The tether can also serve as a long antenna in a magnetized not confined plasma, in contrast with what always happens in any conventional experimental device in terrestrial laboratories. Another physical effect may be the generation of beams of accelerated electrons interacting with the ambient plasma, locally and along the field lines.

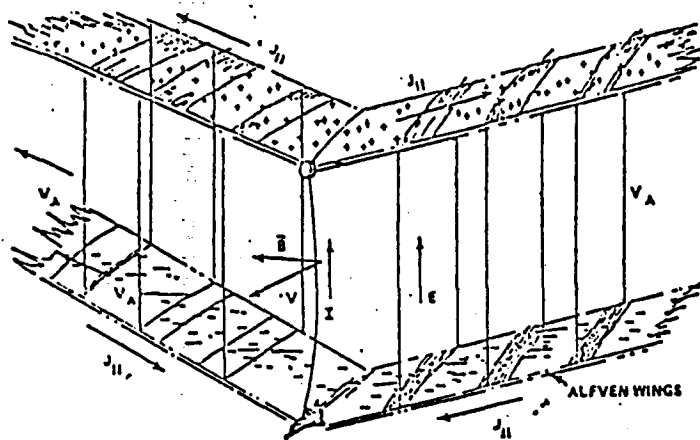

Figure 5. Schematic View of the Upper and Lower Current Sheets Which Spread Out from the Electrodynamics Tether System. The periodic darkened regions represent the outward propagation of Alfvén waves along the magnetic field. There is a net positive charge excess on the top wing and a net negative charge density on the lower wing.

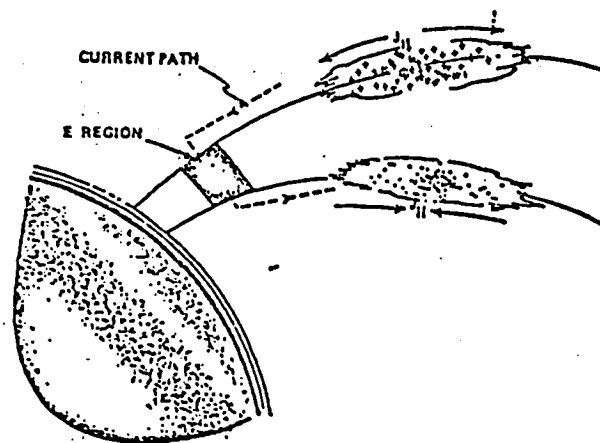

Figure 6. Illustrating the Magnetic Field-Aligned Currents Which Are Caused in the Ionosphere by the Transfer of Electrons from the TSS Satellite to the Shuttle. The net charge imbalance spreads along the magnetic field until the perpendicular resistivity is sufficiently high to permit transverse currents to connect the two magnetic flux shells.

In summary, fundamental plasma processes can be studied. The similarity of conditions in other plasmas in space makes also possible to get new important scientific achievements on the magnetospheres of the giant planets or more generally on the solar system. In particular, an interesting natural situation occurring in the solar system has been identified which resembles that which can be studied close to Earth by the tether techniques: this is the electrodynamic unusual phenomena associated with the Jovian satellite Io (radioemission, UV emission, energetic electron precipitation). The physical parameters close to Io, by simple scaling to the terrestrial case, are such that by analogy similar phenomena are expected to occur close to the tethered subsatellite (Fig. 7).

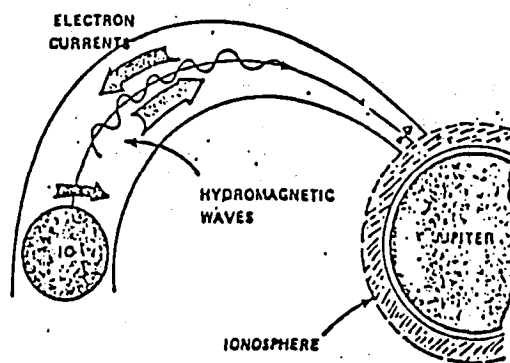

Figure 7. Schematic View of the Interaction of Io with the Rapidly Rotating Jovian Ionosphere. Large magnetic field-aligned currents connect to the Jovian ionosphere, propagating at the Alfvén speed in the moving medium.

Conclusions

A number of exciting physical and technical problems can be studied by means of tethered satellites. At present, two missions are approved: the upward mission essentially for electrodynamic oriented physics; and the downward mission for atmospheric-ionospheric studies. The scientific model payloads used for the feasibility study depending upon the particular scientific aim of each mission are shown in Tables 1 and 2, respectively.

The first launching is presently scheduled for early 1987. It is rewarding to all of us to see that several scientific groups, from other European and not European countries, have expressed their strong interest in joining scientifically this exciting Italy-USA TSS joint venture.

TABLE 1
ELECTRODYNAMIC MISSION EXPERIMENTS

- Current and voltage monitors with a programmable high voltage power supply
- Charge probe to measure charge accumulation on dielectric surfaces
- Current probes to furnish information about current collection on metallic surfaces
- Langmuir probe to measure the flux of ions or electrons (depending on its polarity) when a potential difference exists between it and the satellite skin
- Suprathermal Electron Spectrometer: to furnish velocity and direction measurements concerning plasma electrons relative to their thermal state
- Spherical Retarding Potential Analyzer/Langmuir Probe in combination to get velocity, temperature and density of ions. The instruments are to be mounted on a common fixed boom
- Search Coil Magnetometer to measure magnetic field fluctuations and oscillations mounted on the same boom which carries SRPA/LP
- Photometer to measure the flux of ionizing UV radiation
- Double probe detectors to detect plasma waves

TABLE 2
ATMOSPHERIC MISSION EXPERIMENTS

- Temperature, Wind and Composition Sensor to measure winds, neutral gas composition and temperature
- Ion Drift Monitor to measure ion drift velocity which, coupled with particle flux and magnetic field data, is used for obtaining electric field information
- Ion Mass Spectrometer to measure ion composition and density by means of a time-of-flight type spectrometer
- Retarding Potential Analyzer to provide ion temperatures, concentration and potential of the satellite w.r.t. plasma
- Fluxgate Magnetometer to measure both amplitude and direction of the vector magnetic field mounted on a long fixed boom
- Ionospheric Probe to study the ionospheric density irregularities looking at the phase and amplitude fluctuations on a radio frequency link between Shuttle and satellite

REFERENCES

The following references are to a few historical papers and general papers describing the science rationale for TSS.

- J. D. Isaacs, A. C. Vine, H. Bradner and G. E. Brachus, Satellite Elongation into a True Sky Hook, Nature 151, 682, 1966.
- G. Colombo, E. M. Gaposchkin, M. D. Grossi and G. C. Weiffenback, Shuttle Borne Skyhook: A New Tool for Low-Orbital-Altitude Research, Smithsonian Astrophysical Observatory, Reports in Geoastronomy 1, September 1974.
- G. Colombo and M. D. Grossi, Satellite connected by means of a long tether to a powered spacecraft, United States Patent 1097010, June 27, 1978.
- Proceedings of the UAM/NASA Workshop on the Uses of a Tethered Satellite System, edited by S. T. Wu, Huntsville, Alabama, 1978.
- Tethered Satellite System, Facility Requirements Definition Team Report, by NASA Marshall Space Flight Center and Utah State University, April 1980.
- Addendum to above report; Further Scientific Uses of TSS by National Research Council of Italy, May 1983.

The following documents give detailed description of the instruments flown on Atmospheric Explorer and Dynamics Explorer Satellites which can be considered as indicative of some possible instruments for TSS.

- Atmospheric Explorer Experiments, Special Issue of Radio Science, Vol. 8, N. 4, published by A.G.U., April 1973.
- Dynamics Explorer, Special Issue of Space Science Instrumentation, Vol. 5, N. 4, edited by R. A. Hoffman, Reidel P.C., 1981.

SCIENCE APPLICATIONS II

James Murphy
NASA Headquarters
Geodynamics Branch

The goals of this program are to contribute to the understanding of the solid earth; the origin and evolution of the earth; its internal structure and the dynamics of the core and the mantle; the movements and deformations of the tectonic plates that make up the surface of the earth; its rotational dynamics; the changes in the rotation rate of the earth; the orientation of the pole in space; variations of the gravity and magnetic field of the earth; the origin of the earth and the way in which the solid earth interacts with the oceans and the atmosphere. With these goals, the listed objectives then follow.



Some of the major questions in geodynamics at this time are: What forces drive the plates that make up the surface of the earth? How do they deform during this process? How do the current plate motions compare to those motions that are inferred over geological time scales? How is the crustal strain accumulated and released in the form of earthquakes? What's the pre- and post-seismic deformation in a region that an earthquake occurs in? What is the relationship, if any, between earthquakes and the path of the Earth's pole in space? What are the processes that have led to the formation of the mineral and petroleum deposits, and why do they occur, and why do they occur where they do? Are the variations in the earth's rotation rate associated with the processes occurring within the earth, or are they associated with the processes occurring within the atmosphere? Why is the earth's magnetic field changing?



GEODYNAMICS PROGRAM

- GOAL** - CONTRIBUTE TO UNDERSTANDING OF THE SOLID EARTH;
- ITS ORIGIN AND EVOLUTION;
 - ITS INTERNAL STRUCTURE, COMPOSITION, AND DYNAMICS;
 - THE MOVEMENT AND DEFORMATION OF ITS CRUST;
 - ITS ROTATIONAL DYNAMICS;
 - THE VARIATIONS IN ITS POTENTIAL FIELDS;
 - THE ORIGIN OF THE GEOMAGNETIC FIELD;
 - ITS INTERACTIONS WITH THE OCEANS AND ATMOSPHERE, AND WITH OTHER BODIES IN THE SOLAR SYSTEM.

OBJECTIVES:

- DETERMINE THE PRESENT MOVEMENT AND DEFORMATION OF THE TECTONIC PLATES;
 - DETERMINE THE FORCES WHICH MOVE AND DEFORM THE PLATES;
 - MEASURE AND MODEL CRUSTAL DEFORMATION AT ACTIVE PLATE BOUNDARIES;
 - STUDY THE STRUCTURE AND EVOLUTION OF THE LITHOSPHERE;
 - MEASURE AND MODEL THE EARTH'S GRAVITY AND MAGNETIC FIELDS AND THEIR SECULAR CHANGES;
 - SEEK CAUSATIVE RELATIONSHIPS BETWEEN THE EARTH'S ROTATIONAL DYNAMICS, ITS INTERNAL MASS MOVEMENTS, AND THE EXTERNAL ENVIRONMENT;
 - MEASURE AND MODEL THE INFLUENCE OF THE SUN AND MOON ON THE SOLID EARTH AND OCEANS.
-

GEODYNAMICS - MAJOR QUESTIONS

1. WHAT FORCES DRIVE THE PLATES?
2. HOW DO THE PLATES DEFORM?
3. HOW DO PRESENT PLATE MOTIONS COMPARE TO INFERRED MOTION?
4. HOW IS CRUSTAL STRAIN ACCUMULATED AND RELEASED IN THE FORM OF EARTHQUAKES?
5. WHAT IS THE RELATIONSHIP BETWEEN POLAR MOTION AND EARTHQUAKES?
6. WHAT PROCESSES LEAD TO THE FORMATION OF MINERAL AND PETROLEUM DEPOSITS?
7. ARE VARIATIONS IN THE EARTH'S ROTATION RATE ASSOCIATED WITH THE MANTLE AND CORE?
8. WHY IS THE EARTH'S MAGNETIC FIELD CHANGING?

The answers to these questions fall into two categories. One is measuring position and orientation and another one is measuring the gravity and magnetic field. In the area of positioning, laser ranging experiments have been conducted to the moon and earth satellites especially the Lageos satellite which is specifically designed solely for laser ranging experiments. In addition, we have conducted experiments using very long baseline interferometry and are now beginning to work with the Global Positioning System (GPS) technique. The global positioning system is a possible method for improving our ability to determine positions on the surface of the earth and more importantly changes in position and changes in length of the order of a few centimeters per year.



Laser ranging and VLBI systems have been deployed on many of the major tectonic plates that make up the surface of the earth in order to make measurements of plate motion and near the boundaries of the plates, to make measurements of crustal deformation. In addition, an important question is what is the stability of the plates. It turns out that the largest earthquake that occurred in the United States occurred in Missouri and not along the San Andreas Fault. While earthquakes occur because these plates are rubbing against each other when they buckle in the middle very large earthquakes occur.



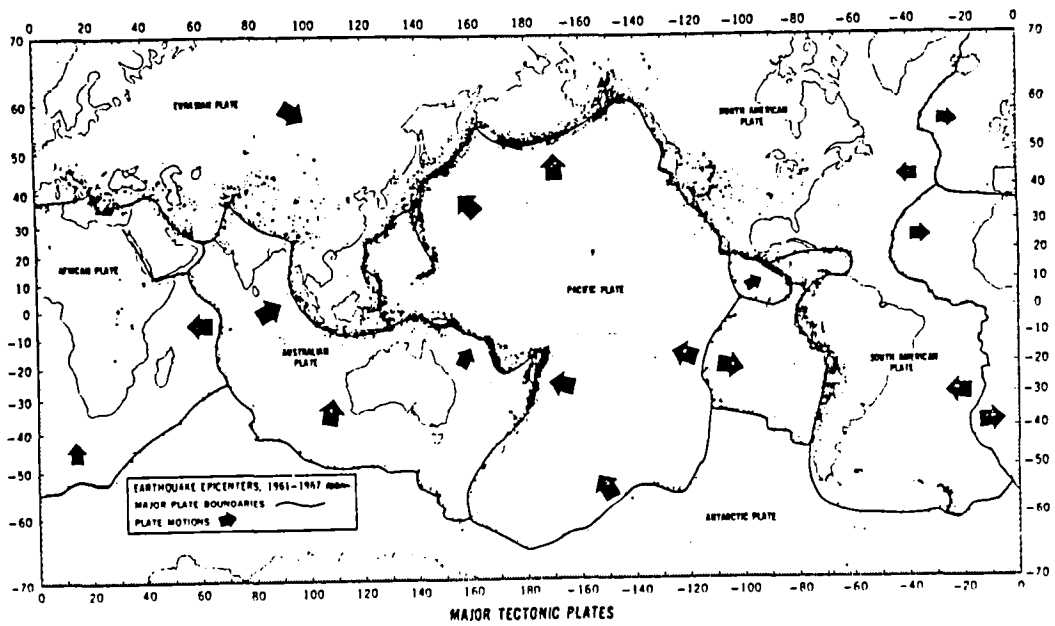
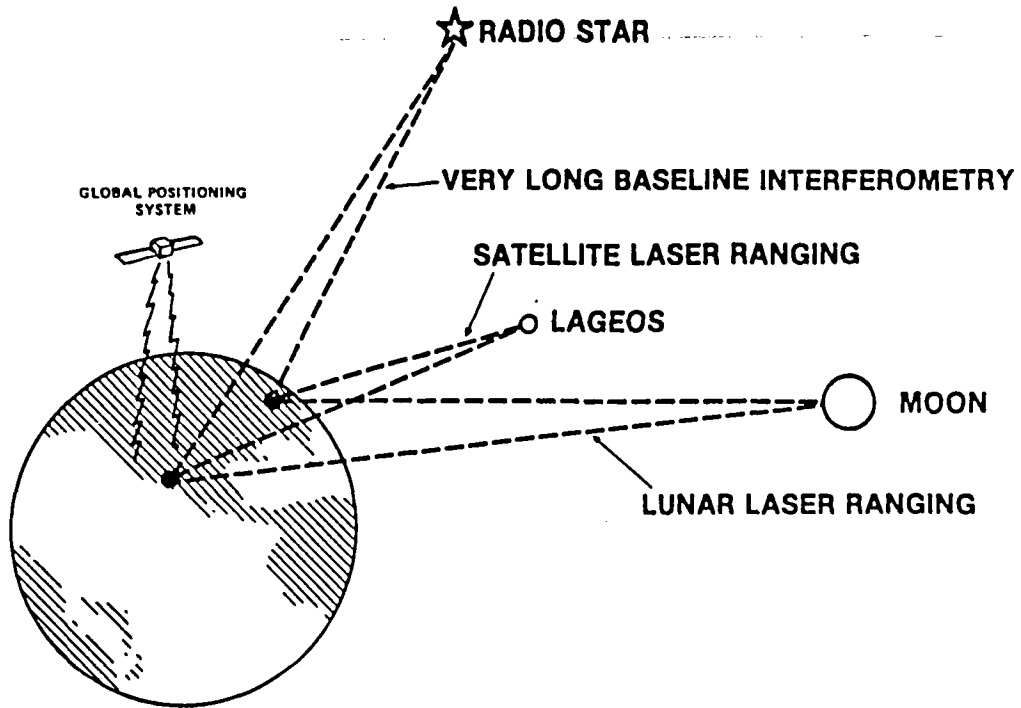

These results associated with measuring plate motion and plate stability were obtained from laser ranging and the VLBI.

Two points on opposite sides of the San Andreas Fault were occupied by Satellite Laser Ranging Systems. The length (nearly 900 km) has been monitored now for a decade. The difference between the changes in length from the points far from the boundary and local ground measurements near the fault are a measure of the energy being stored in the system.

As a by-product of some of these measurements the position of the Earth's pole of rotation is monitored very accurately. This chart is an example of the x and y component of the pole obtained from Lageos over the last five years. Geophysicists do spectral analyses of this data and are able then to obtain information about the interior of the earth.

CRUSTAL MOTION RESULTS

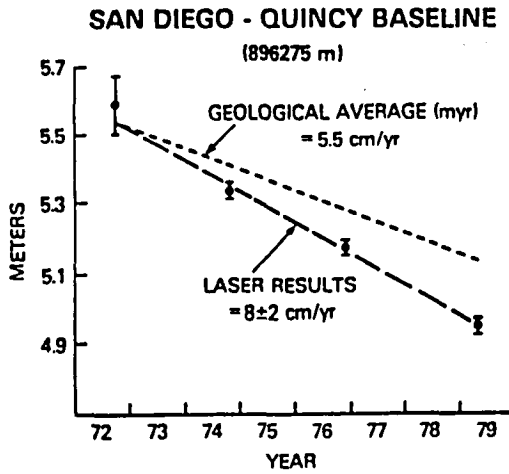

MOTION ALONG
THE SAN ANDREAS FAULT

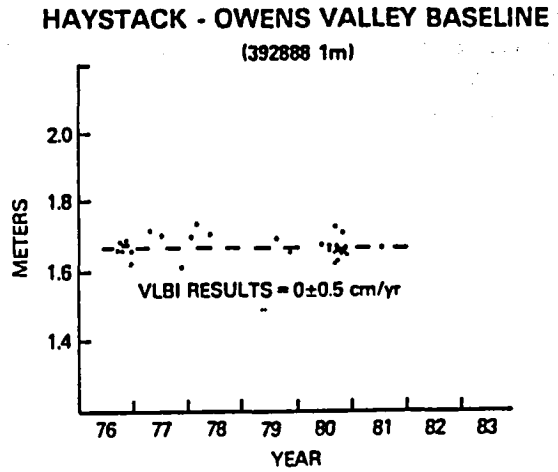

STABILITY ACROSS THE U.S.

LAGEOS POLAR MOTION MEASUREMENTS MAY 1976 - AUGUST 1981

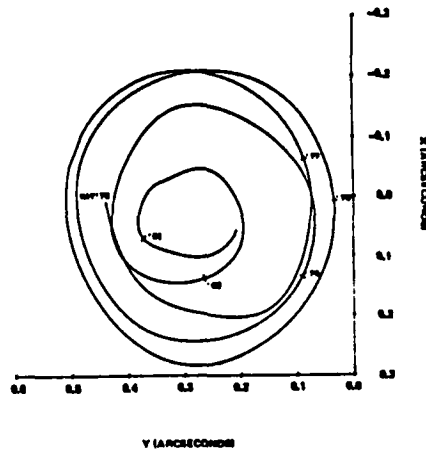
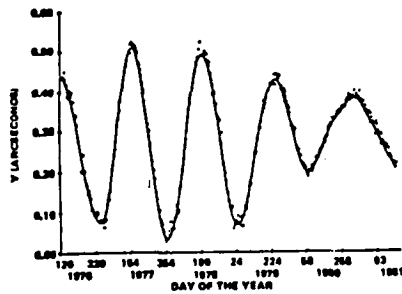
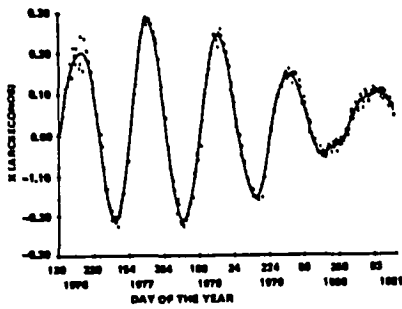

In a transition between trying to understand how these plates are moving with respect to each other and what's driving the motion, it turns out there are competing theories as to why the tectonic plates on the surface of the earth are moving with respect to each other. Not all terrestrial bodies have tectonic plate motion. Relevant questions are: Are the sizes of these cells the whole depth of the mantle?; Is there a dual cell?; What are the sizes of these cells?; Is the mechanism the same in the ocean basins as it is in the continental regions? One way in which one can shed information on this particular problem is through refinements in the gravity field and to a degree through refinements in the magnetic field.



This chart outlines the objective, strategy, and elements of the Geopotential Research Program Plan.



CRUSTAL MOVEMENT AND DEFORMATION

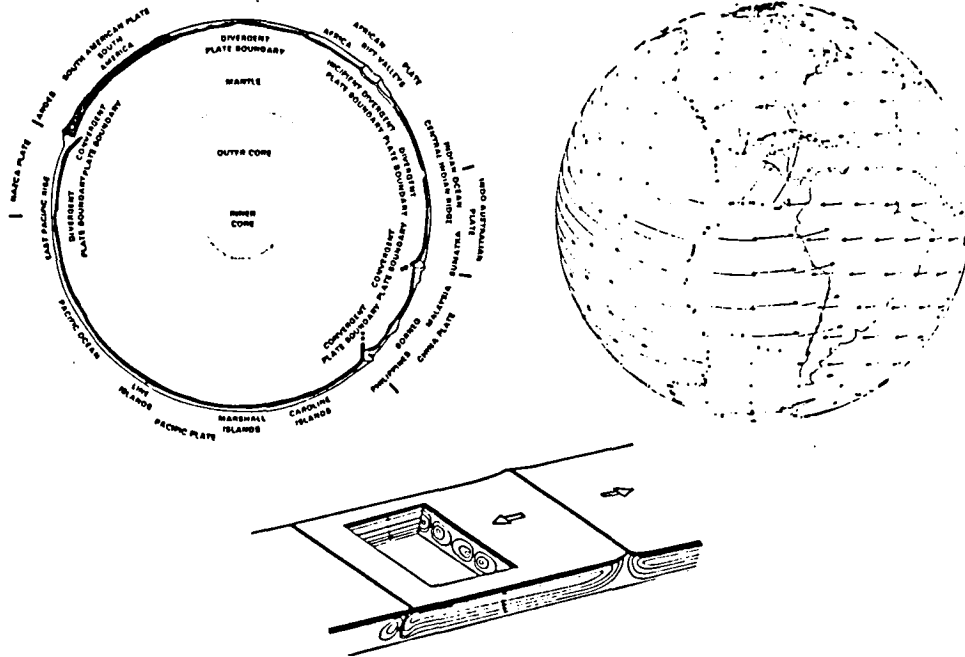

GEPOTENTIAL RESEARCH PROGRAM PLAN

- OBJECTIVE:** PROVIDE GLOBAL GRAVITY FIELD AND MAGNETIC FIELD INFORMATION REQUIRED FOR SCIENTIFIC STUDIES OF THE SOLID EARTH AND THE OCEANS AND FOR OPERATIONAL NEEDS OF THE FEDERAL AGENCIES.
- STRATEGY:**
- 0 REFINE EXISTING MODELS BY SELECTING BEST DATA SETS AND INCLUDING DATA NOW AVAILABLE FROM SPACE MISSIONS AND OTHER SOURCES.
 - 0 ACQUIRE ACCURATE DATA ACHIEVABLE WITH GEOPOTENTIAL RESEARCH MISSION.
 - 0 ACHIEVE ULTIMATE GRAVITY/MAGNETIC FIELD MEASUREMENT ACCURACIES; ESTABLISH LONG-TERM MAGNETIC FIELD MONITORING.
- ELEMENTS:**
- 0 FIELD MODELLING UPDATE/SCIENTIFIC INTERPRETATION
 - 0 GEOPOTENTIAL RESEARCH MISSION/MAGNETIC MONITOR MISSION
 - 0 SCIENTIFIC INTERPRETATION (GRM/MMM)
 - 0 ADVANCED MISSIONS
 - 0 CRYOGENIC GRAVITY GRADIOMETER
 - 0 TETHERED MAGNETOMETER

This chart displays a geoid model, the Goddard Earth model GEM10B which has in it 1° x 1° surface gravimetry data, satellite altimetry data, tracking data from satellites. (laser ranging optical observations, and radio observations).

We can see the low south of India which is actually a "wake" in the lithosphere due to India's rapid (on a geological time scale) motion from Antarctic until it crashed into the Eurasian Plate causing the creation of the Himalayas. This is an example of a continent-continent collision. The Nazra Plate under thrusting South America is an example of an ocean-continent plate collision (which created the Andes Mountains). Ocean-ocean plate collision can be found in the Aleutian Arc. All of these produce gravity signals.

In this chart the bar shows the current resolution of the previous global gravity model, GEM10B. In order to decipher which one, if any, of these particular models actually represents what's going on there has to be greater resolution. It seems that few good tracks over this region with a gravity gradiometer on a tethered system would be able to shed some light on this particular tectonic problem.

**NASA/GODDARD SPACE FLIGHT CENTER
GLOBAL DETAILED GRAVIMETRIC GEOID BASED UPON
A COMBINATION OF THE GSFC GEM 10B EARTH MODEL
AND 1° x 1° SURFACE GRAVITY DATA**

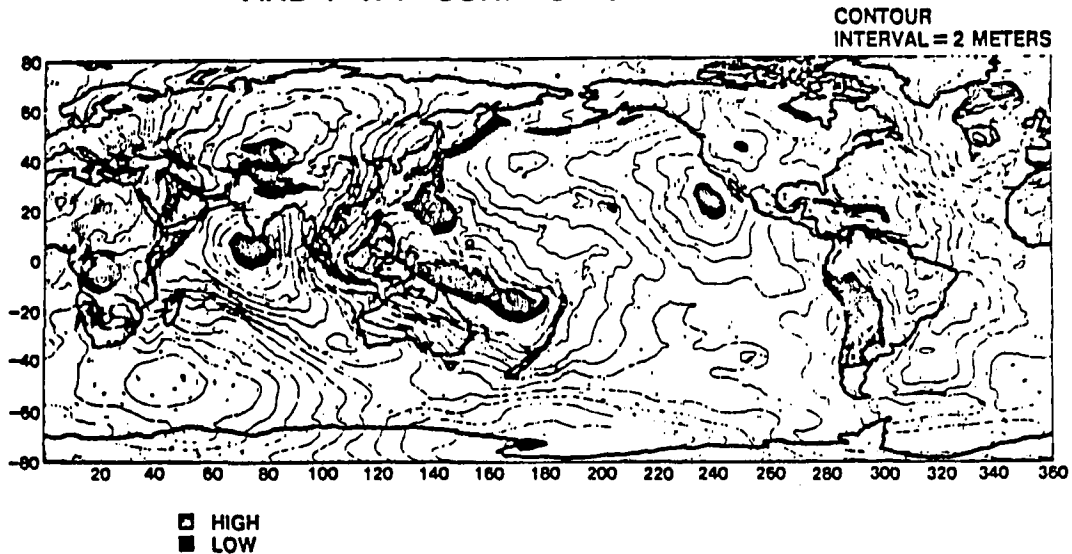

**CONTINENT—CONTINENT
COLLISION**

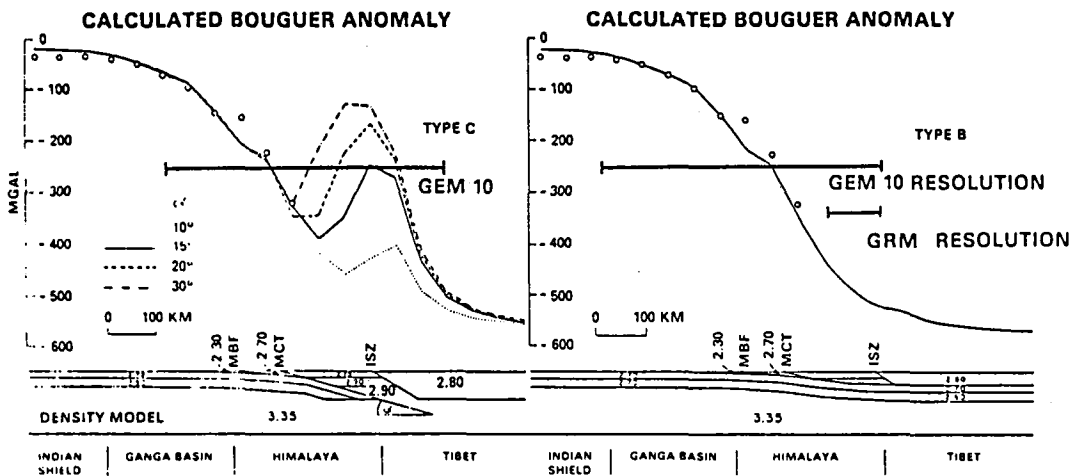

- GRAVITY ANOMALIES OVER THE HIMALAYA WILL INDICATE WHICH UNDERTHRUSTING MODEL IS CORRECT
- CURRENT DATA DOES NOT REACH THE CRITICAL AREA

FROM WARSI AND MOLNAR, 1977

This illustration shows ocean areas where there is a fair amount of detailed gravity information from satellite altimetry. Satellite altimetry more or less directly measures the ocean geoid from which one can then derive a gravity anomaly map and one can infer a particular pattern when using this map along with that gravity information, bathymetric data, heat flow, etc. It would be good to do on the continents what has begun to be done in the ocean areas but the gravity field details are not known well enough.



Here is displayed the Kentucky anomaly which was recently found. Geophysicists were able to take Magsat data coupled with their aeromagnetic data, and surface gravity data and come up with a model of the possible mechanism that caused this crustal anomaly.



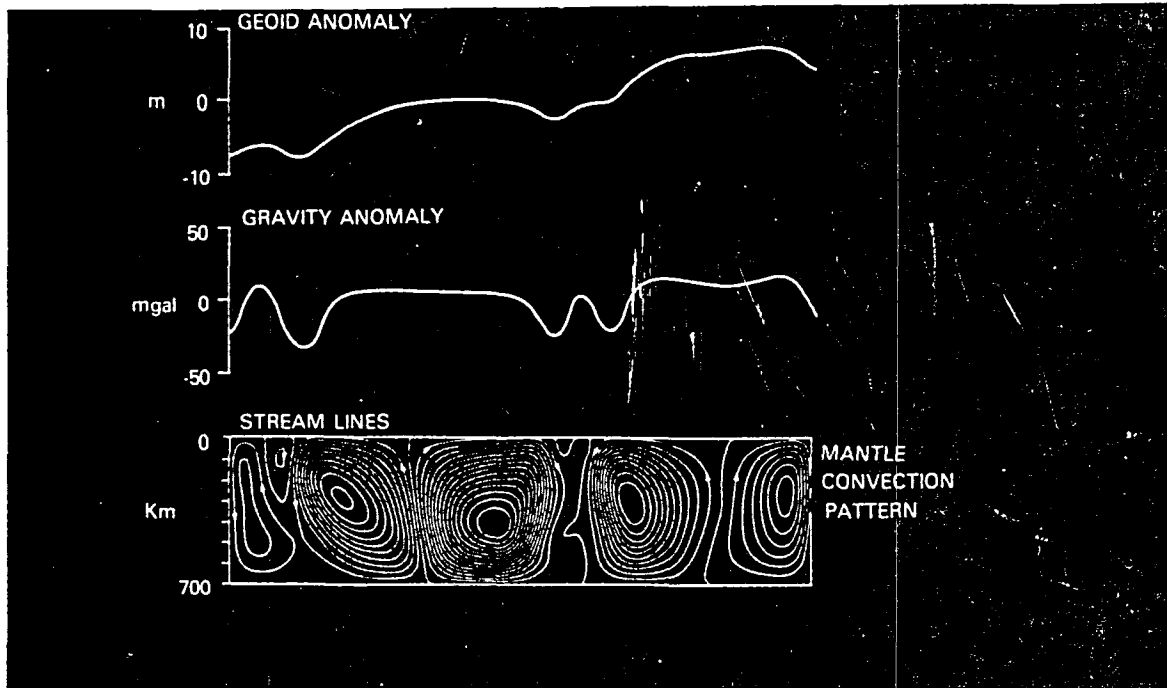

EXAMPLE OF GRAVITY AND GEOID ANOMALIES PRODUCED BY CONVECTION IN THE MANTLE (AFTER WATTS AND DALY, 1981)

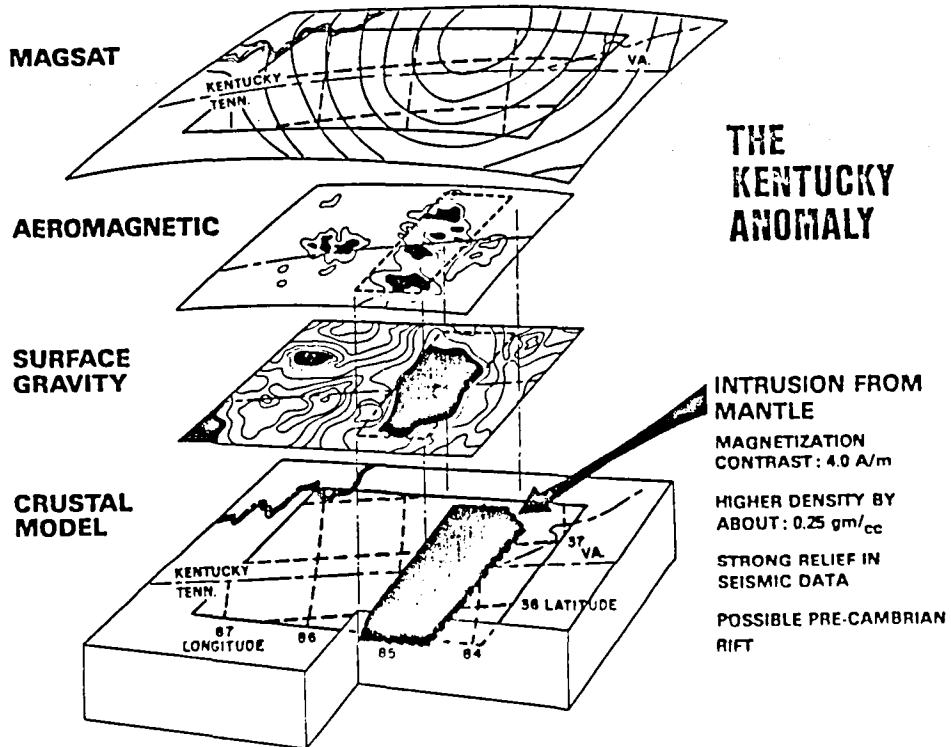

The main field of the earth is changing. In fact, it changes by as much as 7% in a decade in various regions. Geomagnetists modeled the main field using observatory data and satellite data when available. They model it in terms of spherical harmonical coefficients and sometimes linear and quadratic terms in time of those coefficients but we find that these models don't hold up very well with time. In the Magsat mission, we were able to do a fairly decent magnetic field model with three days worth of data that occurred during the first 10 days of the mission. Not an awful lot of data is required in order to do an update. It would be very helpful 7 or 8 years after Magsat flew to update the field and make improvements in our knowledge of the way the main field is changing.



This chart displays information obtained from polar satellites called Polar Orbiting Geophysical Observatories. These anomaly maps were produced to see whether the anomalies coincide with the paleo-plate boundaries. There is good agreement. For example, between Australia and Antartica and between South America and Africa. This has been done with gravity and magnetic anomaly maps. This is felt to be an important contribution to paleomagnetism.



THE EARTH'S MAGNETIC FIELD AND ITS CHANGE: 1980

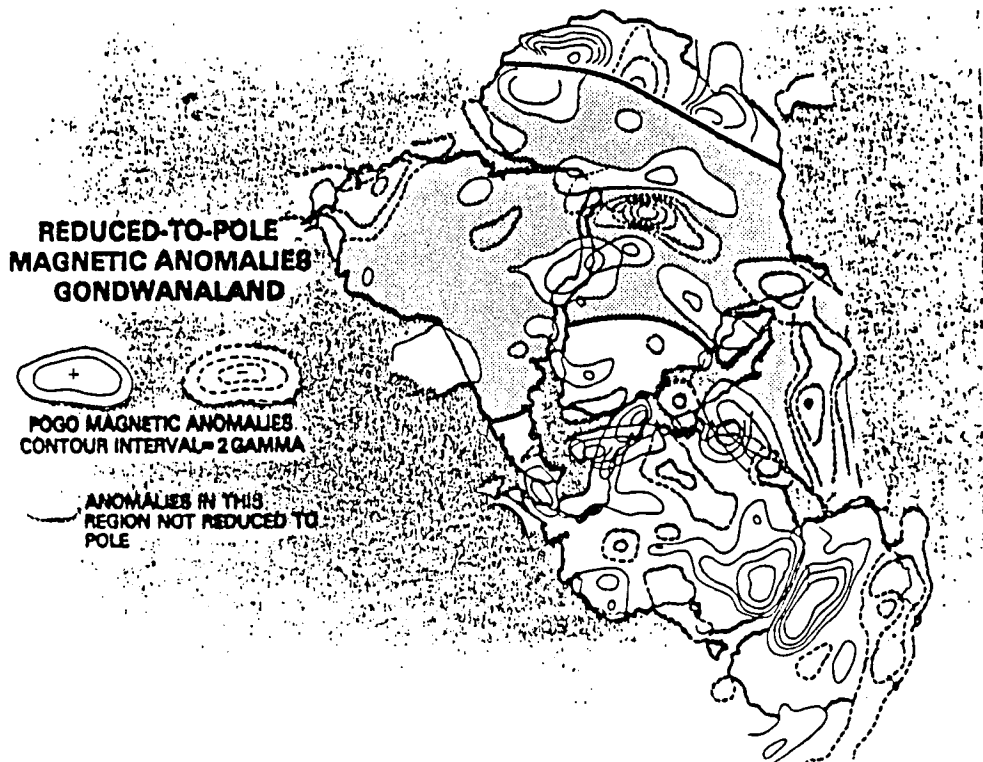
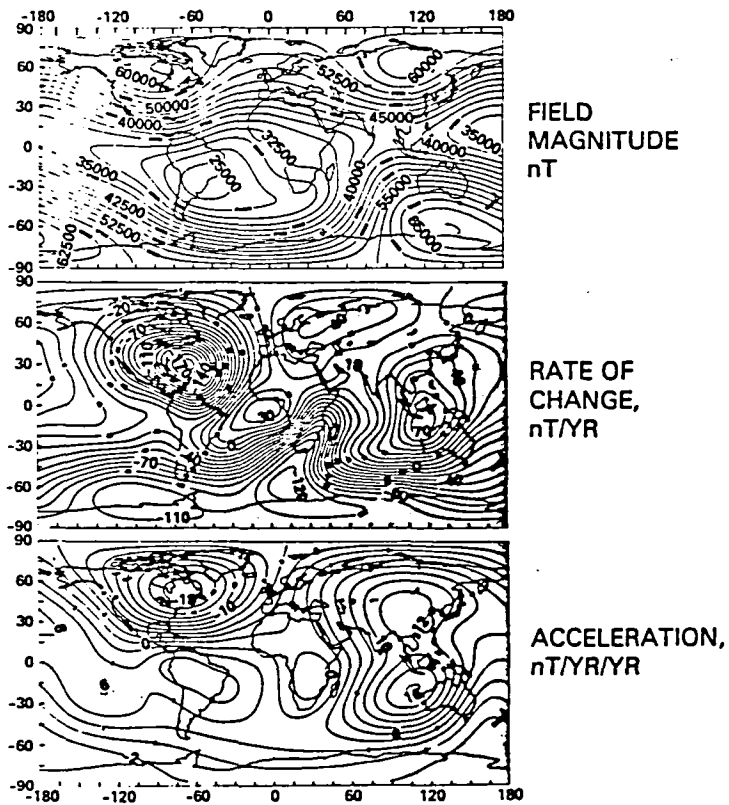

This chart serves as a transition to tie together geodynamics with the tethered satellite system.



TETHERED SATELLITE SYSTEM - GEODYNAMICS

GRAVITY FIELD:

- 0 IMPROVED ACCURACY AND RESOLUTION
 - 5° x 5° TO ORDER OF .1 MGAL
 - 1° x 1° TO ORDER OF 1 MGAL
 - 1/2° x 1/2° TO ORDER OF 5 MGAL
- 0 CONTINENTAL/OCEANIC GRAVITY TRANSITION
- 0 SHORT WAVELENGTH GEOID

MAGNETIC FIELD:

- 0 IMPROVED ACCURACY AND RESOLUTION
 - 1 NT ANOMALY MAPS WITH 50 KM RESOLUTION
- 0 REMOVAL OF (N/S) TRENDING IN ANOMALY MAPS
- 0 CORE FIELD/SECULAR VARIATION UPDATE
 - MAGSAT MODEL PLUS 7 YEARS

POSITION DETERMINATION

- 0 DUAL ALTITUDE MULTILATERATION

ELECTRODYNAMIC INTERACTIONS

Nobie Stone
Marshall Space Flight Center

The orbiter moves in an eastward direction, causing the conducting tether to cut across the earth's geomagnetic field lines at very high speeds (~ 8 km/s). This motion creates a $\vec{V}_O \times \vec{B}$ EMF that forces the current, in a classic sense, up the tether. In a more physical sense, the EMF creates a positive potential on the satellite at the top which attracts electrons and forces them down through the tether. These electrons must be actively emitted back into the ionosphere from the orbiter by an electron gun or plasma bridge or some similar charge emission device.



The two classes of applications of electrodynamic interactions exist: technological and scientific. And, as will be shown, many of the technological problems are of scientific interest or, in other words, the answers to many of the scientific questions are required in the technological applications of the electrodynamic tether. It, therefore, affords an interesting union between science and engineering.



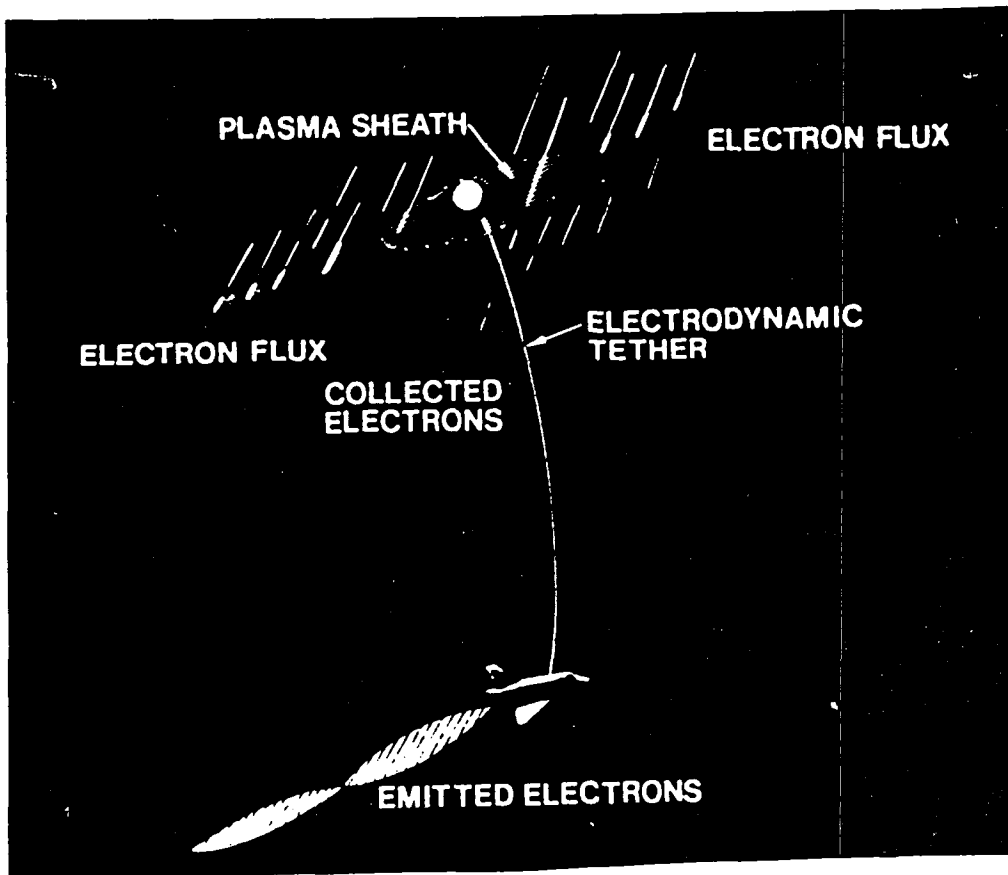

ORGANIZATION:	MARSHALL SPACE FLIGHT CENTER	NAME: DATE:
<p style="text-align: center;">APPLICATIONS OF TETHER ELECTRODYNAMIC INTERACTIONS</p> <ul style="list-style-type: none"> o TECHNOLOGICAL <ul style="list-style-type: none"> o GENERATION OF THRUST o GENERATION OF POWER o SCIENTIFIC <ul style="list-style-type: none"> o PLASMA WAVES AND INSTABILITIES o IONOSPHERIC CONDUCTIVITY o BIRKELAND CURRENTS o PROCESS SIMULATION 		

This chart contains information that has come originally from Smithsonian Astrophysical Observatory via Lewis Research Center. It describes power generation using the electrodynamic tether. The $\vec{V}_0 \times \vec{B}$ EMF attracts electrons to the top, and drives them down through the tether where they are emitted actively from the space station or orbiter. Current levels of 5 amps through a 100 km tether can produce upwards of 80 kW of power, which is sufficient to power a good size space station. The high voltage power produced would be particularly useful in driving devices such as particle accelerators. Of course, if it is to be used to operate electronics or for general utility power, then some power conditioning is necessary.



This chart indicates concepts of the tether thrust generator. Notice that its operation is the inverse of the tether power generator.



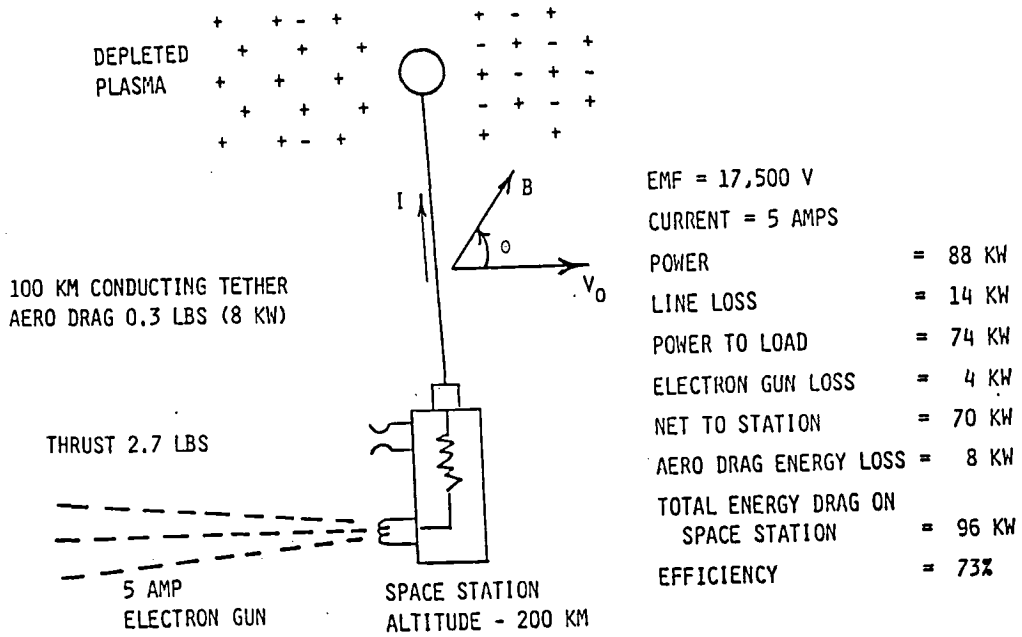

TETHER POWER GENERATOR

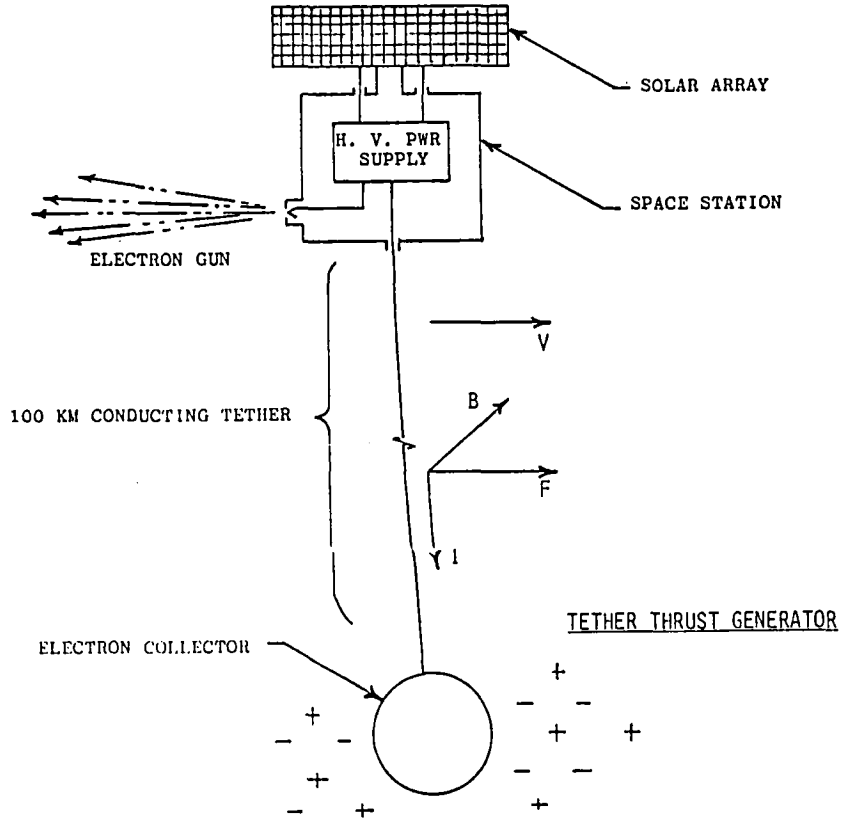

It is interesting to compare the efficiency of the tether power system with other competing power sources such as fuel cells. The major difference is that the fuel cell only makes use of the chemical energy in the fuel while the tether power system uses both the chemical energy as well as the kinetic energy of the fuel. As a result, it is approximately two and one-half times more efficient according to the LeRC calculations. Another interesting idea uses the fact that the thrust levels needed to make up the loss in kinetic energy are relatively small. On a space station operating with an open loop life support system, if water and various other waste products are expelled through a nozzle in the right direction, it turns out that the resulting thrust can just about make up the kinetic energy loss.



The first few areas of concern such as high voltage isolation at the spacecraft and tether insulation problems are basically engineering problems and I have great faith that with a little work and thought they can be solved. The last one, however, is a little more difficult and challenging and really it should be stated a little differently. It consists really of a dual problem. First, how much electron current can be drawn across the sheath of a very high voltage satellite and, second, with what efficiency can the current loop be closed through the ionosphere. This is an interesting question because it brings a unique union between science and engineering. Obviously for the technological applications, this is a very critical question. There can be no useful power generation if a significant amount of current cannot be drawn from the ionosphere. There can be no useful thrust levels generated if the current level is not high enough. From an engineering point of view, it is a very critical question. But the very nature of the question itself is the basis for a great deal of the scientific interest.



ORGANIZATION:	MARSHALL SPACE FLIGHT CENTER	NAME: DATE:
<p style="text-align: center;">TETHER POWER GENERATOR - COMPARATIVE EFFICIENCY</p> <ul style="list-style-type: none"> ● HYDROGEN - OXYGEN CONSUMPTION TO OVERCOME ELECTRICAL AND AERODYNAMIC DRAG OF THE TETHER POWER GENERATOR - 0.35 LBS/KWH. ● HYDROGEN - OXYGEN REACTIANT CONSUMPTION FOR 73 PERCENT EFFICIENT FUEL CELL - - - - - 0.86 LBS/KWH. ● TOTAL TETHER POWER GENERATOR DRAG (~3 LBS) CAN BE OFFSET BY EJECTION OF WASTE WATER. 		

ORGANIZATION:	MARSHALL SPACE FLIGHT CENTER	NAME: DATE:
<p style="text-align: center;">LIMITATIONS AND AREAS OF CONCERN FOR TETHER POWER AND THRUST GENERATION</p> <ul style="list-style-type: none"> ● USEFUL THRUST OBTAINED FROM TETHER ONLY WHEN MAGNETIC FIELD ORIENTATION IS SUCH THAT AVERAGE THRUST IS PARALLEL TO V_0. ● HIGH VOLTAGE ISOLATION AT THE SPACECRAFT. ● HIGH VOLTAGE INSULATION OF THE TETHER. ● HIGH POWER, HIGH-TO-LOW VOLTAGE CONVERTER. ● PLASMA-ELECTRODYNAMIC INTERACTIONS AFFECTING RETURN CURRENT LOSSES. 		

There are two limiting theories of how current is drawn to the high voltage satellite from the ionosphere. The top part of the figure shows a case which is strictly electrostatic. The sheath of the high voltage satellite extends out a large distance and any electrons that pass the boundary of the sheath due to their thermal motion simply fall down through the potential well and are collected by the satellite. Relatively high currents can be collected this way and this probably represents the maximum that can be expected. The lower figure is at the opposite end of the spectrum. In fact, we don't have a simple electrostatic case. The ionosphere is a magnetized plasma and particles are constrained to move along the magnetic field lines. In this case, it is assumed that the collection process is dominated by the magnetic field and that electrons are not able to cross the field lines. As a result, electrons can be collected only when they are spiraling along fields that intersect the satellite. The area of collection, therefore, is the cross sectional area of the satellite. In practice, the current collecting capability is somewhere between these extremes.



Assuming that it is possible to draw all of the current across the sheath that is needed, we come to the next question. What happens to the current that we have drawn and expelled from the system? Drawing electrons from the top has left a region of positive space potential. In reemitting the electrons at the bottom has created an electron cloud. From the engineering point of view, the circuit needs to be closed. Current has to flow and the engineer is concerned with what impedances must be overcome, if there are transmission line type losses and so forth. From the scientific point of view, this is simply an unacceptable circumstance in nature. Somehow the charge must get back together. The question then is where does this occur and what mechanisms are involved.



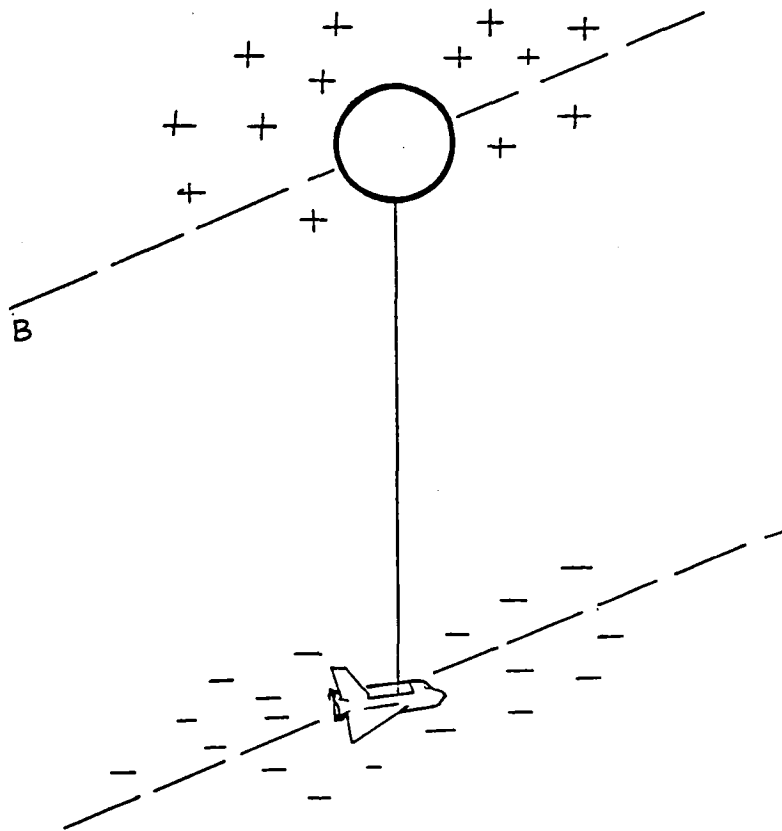
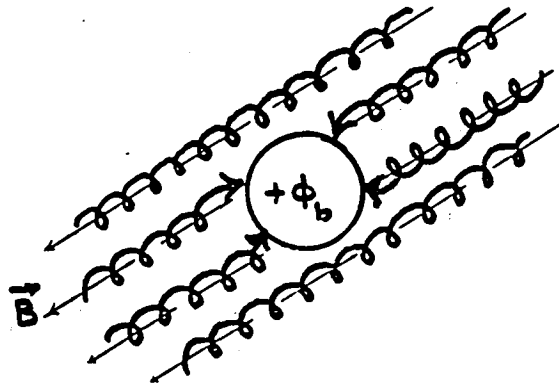
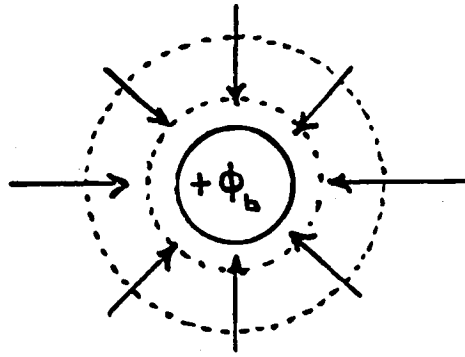

If these charge clouds are deposited on field lines which are some 10's or 100's of km apart, they probably will be constrained to move along the field lines. They could be expected to move down field lines into the vicinity of the E region of the ionosphere where there are sufficient collisions with neutrals to allow the electrons to migrate across the field lines and close the circuit.



Satellite IO has its orbit entirely immersed in the Jovian magnetosphere and as such it cuts across the field lines as it orbits around Jupiter in much the same way as the tethered system would in earth orbit. IO is, of course, large. One of the theoretical explanations of what happens there states that there is a very large EMF created across IO and as a result, charged particle currents are emitted and travel up and down the field lines, recombine in the lower ionosphere of Jupiter and create decimeter radiation when they do so. The system obviously has some similarities to the tether system on earth. The tether allows us to have an extremely large scale-size experiment which has not been possible before. This then allows us to study physical mechanisms and effects that may be applicable to IO through "process simulation."



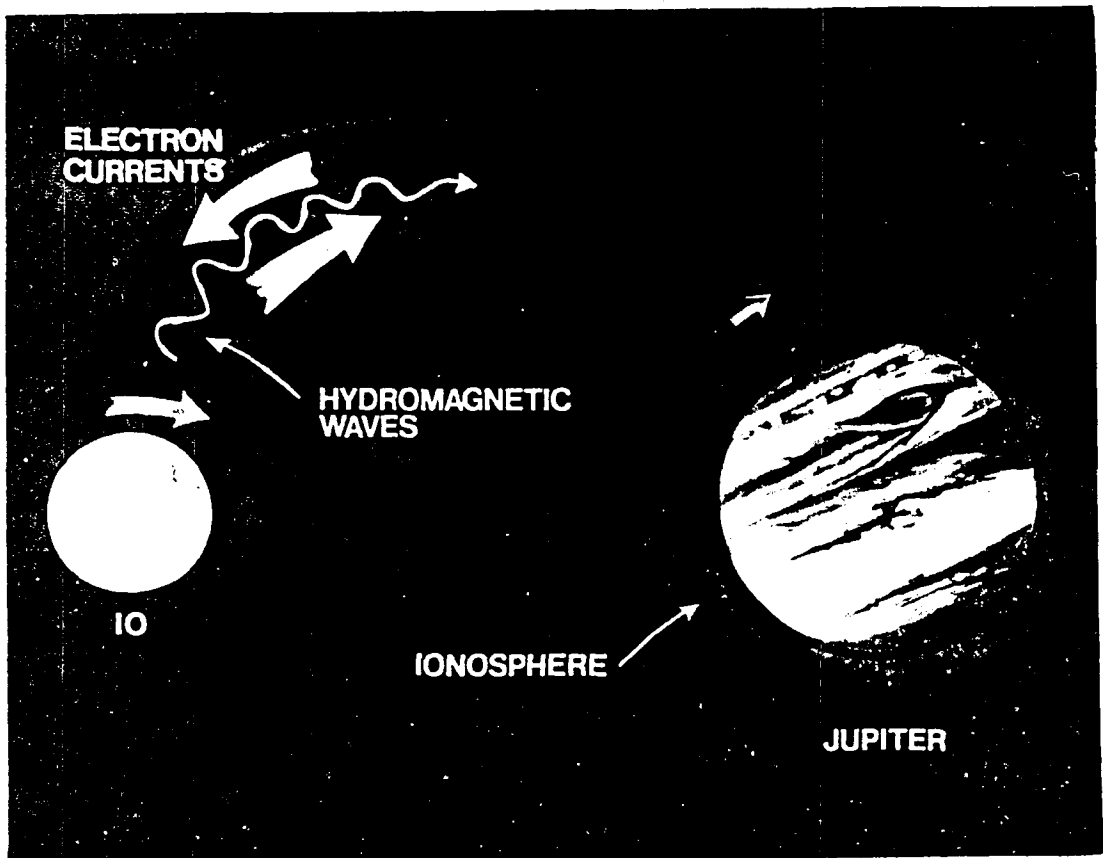
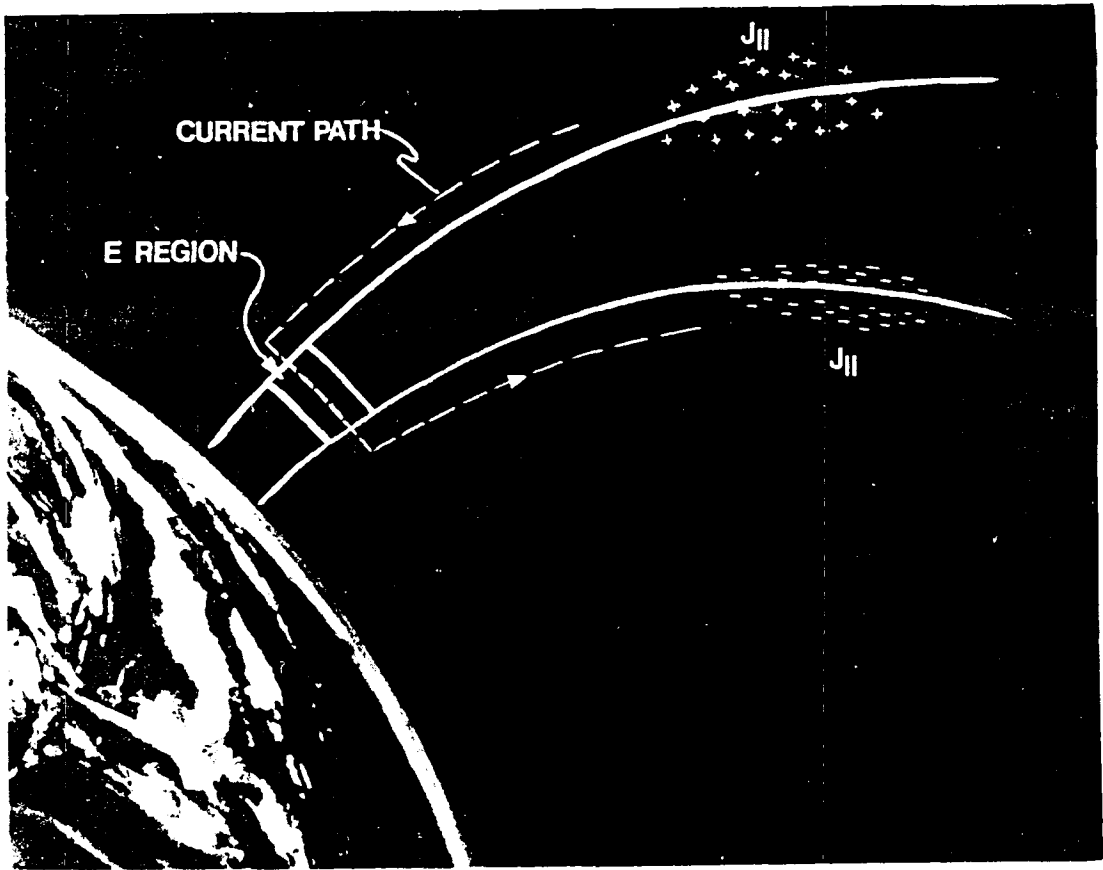

This chart defines Qualitative Scaling. Qualitative scaling requires that if a quantity is much greater than unity in space, then it must be much greater than unity in the experiment, but not necessarily to the same order of magnitude. The opposite equality of course applies also. Only when the quantity is approximately unity in space does it have to be closely approximated by the experimental quantity.



Several cases are shown on the far right. In the case of the 100 m inflated conducting tethered balloon the ionospheric conditions are both supersonic and subAlfvénic (S and M_A) i.e., the flow speed relative to the ion acoustic speed is greater than 1 but much less than the Alfvén velocity. This is exactly the condition for IO moving through the Jovian magnetosphere. The plasma Betas and the scale sizes in terms of the Debye length and the Larmor radii are also very well scaled. So one would expect that at the very least process scaling for cases such as that of IO will provide a valid comparison. In the ionosphere we gain a great extension of the parameter space for scaled experiments over the laboratory.



QUALITATIVE SCALING

DEFINITION: DIMENSIONLESS QUANTITIES RELEVANT IN A CERTAIN CONTEXT ARE KEPT QUALITATIVELY THE SAME IN THE LABORATORY AS IN SPACE

<u>IN SPACE</u>	<u>IN THE LABORATORY</u>
$X_S \gg 1$	$X_L \gg 1$
$X_S \ll 1$	$X_L \ll 1$
$X_S \sim 1$	$X_L \sim X_S$

AFTER FALTHAMMER (1974)

TABLE 1. PLASMA PROPERTIES AND SCALING PARAMETERS

PARAMETER	LABORATORY	IONOSPHERE @ 300 km	JOVIAN MAGNETOSPHERE @ 10
$N_{i,e}$ [cm ⁻³]	10 ³ - 10 ⁶	5 X 10 ⁵	2 X 10 ²
T_e [K ^o]	10 ³ - 10 ⁴	2.5 X 10 ³	~ 10 ⁵
T_i [K ^o]	<< T_e	1.5 X 10 ³	~ 10 ⁵
B [G]	-	0.5	2 X 10 ⁻²
V_o [km/sec]	> 6	7.7	5.6 X 10 ¹
R_o (effective) [km]	10 ⁻⁵ - 10 ⁻⁴	0.1	3.3 X 10 ³
M_i (AV) (AMU)	2, 28	20	~ 1
$S = (M_i V_o^2 / 2kT_e)^{1/2}$	> 3	6	1.4
$M_A = (4\pi N_i M_i)^{1/2} V_o / B$	-	5 X 10 ⁻³	2 X 10 ⁻²
$M_N = V_o \left[\frac{5k(T_e + T_i)}{3M_i} + \frac{B^2}{4\pi N_i M_i} \right]^{-1/2}$	-	5 X 10 ⁻³	2 X 10 ⁻²
$J = 8\pi N_i k (T_e + T_i) / B^2$	-	3 X 10 ⁻⁵	2 X 10 ⁻⁴
$R_{in} = 4\pi R_o V_o / C^2$	-	6 X 10 ⁷	6 X 10 ⁷
$R_n / R_L (e)$	-	4 X 10 ³	7 X 10 ⁵
$R_n / R_L (i)$	-	2 X 10 ¹	2 X 10 ⁴
R_i / λ_D	0.4 - 40	2 X 10 ⁴	2 X 10 ⁴
$R_o / \lambda_{i,e}$	10 ⁻⁸ - 10 ⁻⁷	2 X 10 ⁻¹	3 X 10 ⁻³
$\omega_{pe} / \tau : \tau = R_o \text{ (effective)} / V_o$	10 ¹¹ - 10 ¹²	5 X 10 ⁵	5 X 10 ⁷
ω_{pi} / τ	10 ⁹ - 10 ¹¹	3 X 10 ³	1 X 10 ⁶
ω_{ce} / τ	-	1 X 10 ⁵	2 X 10 ⁷
ω_{ci} / τ	-	3	1 X 10 ⁴

Another potential experiment involving process scaling is the study of the expansion of plasma from a high density area into a low density area or into vacuum. This may seem rather simplistic and mundane but some interesting things happen. In the expansion process, if we look at the leading edge as the ions are accelerated, the electrons being more mobile move ahead and create an electric field. An electric field tends to decelerate the electrons and accelerate the ions. As a result an ion front is created, as seen in the third frame, which is ion rich and follows the electron cloud. The electrons continue to move out because they continually gain energy from an essentially infinite source of thermal energy in the ambient plasma. As a result, the ion velocity increases approximately linearly and, ultimately, ions attain the thermal speed of the electrons. Only a few percent of the ions attain this speed, but it is an impressive process because that represents a 100 to 1000 fold increase in their energy. In nature such processes may be very significant as plasma expands from a region of high density on one side of the plasma pause, for example, to a low density region on the other side. In this case, even the few percent of the dense plasma which become energetic may be a significant factor in the low density region since density may decrease by 3 orders of magnitude across such boundaries.



This chart illustrates a two ion expansion process. When the heavy ion is dominant, it accelerates more slowly, resulting in a stronger bipolar electric field. This stronger field, in turn accelerates the light ions even more rapidly than if they were the only species. As a result, the plasma mixture becomes enriched with light ions in the expansion front. As in the single ion plasma, the light ions ultimately attain the thermal speed of the electrons.



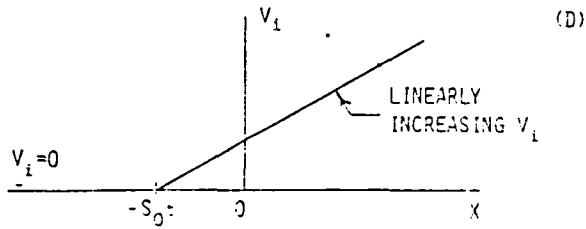
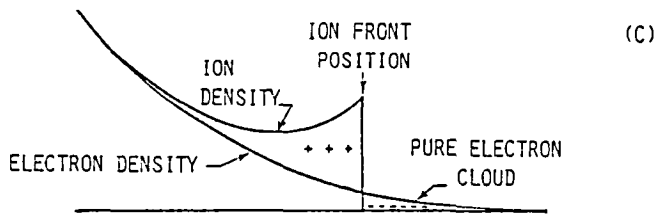
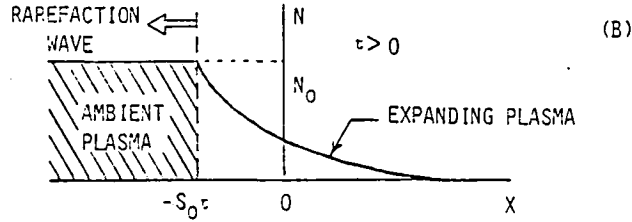
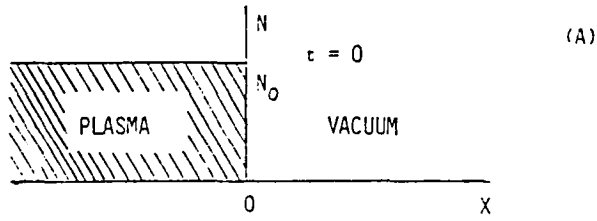

$N_0(O^+) \gg N_0(H^+)$ TWO IONS

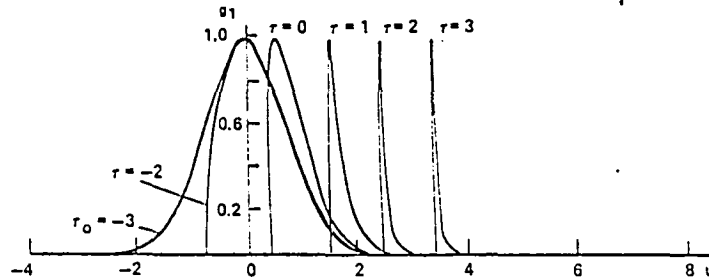
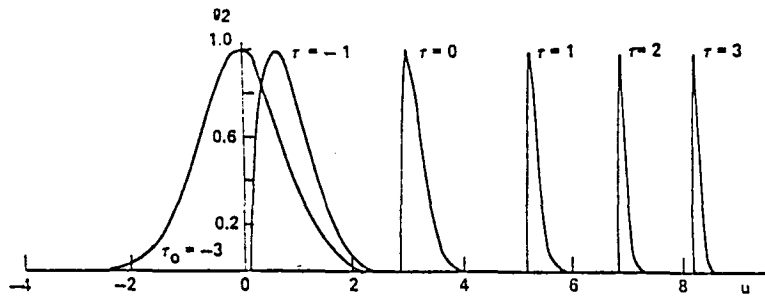

This chart depicts how these types of experiments might be carried out using the tether. The tether satellite being supersonic creates a void behind it, which can be easily studied by use of boom or maneuverable subsatellite-mounted diagnostic instruments.



This chart shows the Use of Multiprobes With the Electrodynamic Tether to measure VLF waves, particle acceleration, ionosphere currents, and Alfvén waves at various regions of interest. In summary, from these few examples, it is apparent that the electrodynamic tether offers new potential for unique scientific experiments which should enhance our understanding of space plasma physics and in particular certain classes of solar system plasma phenomena, and that these science studies will also address a number of key engineering concerns which may open up new power and thrust generation technology that could be a significant factor in future space operations.



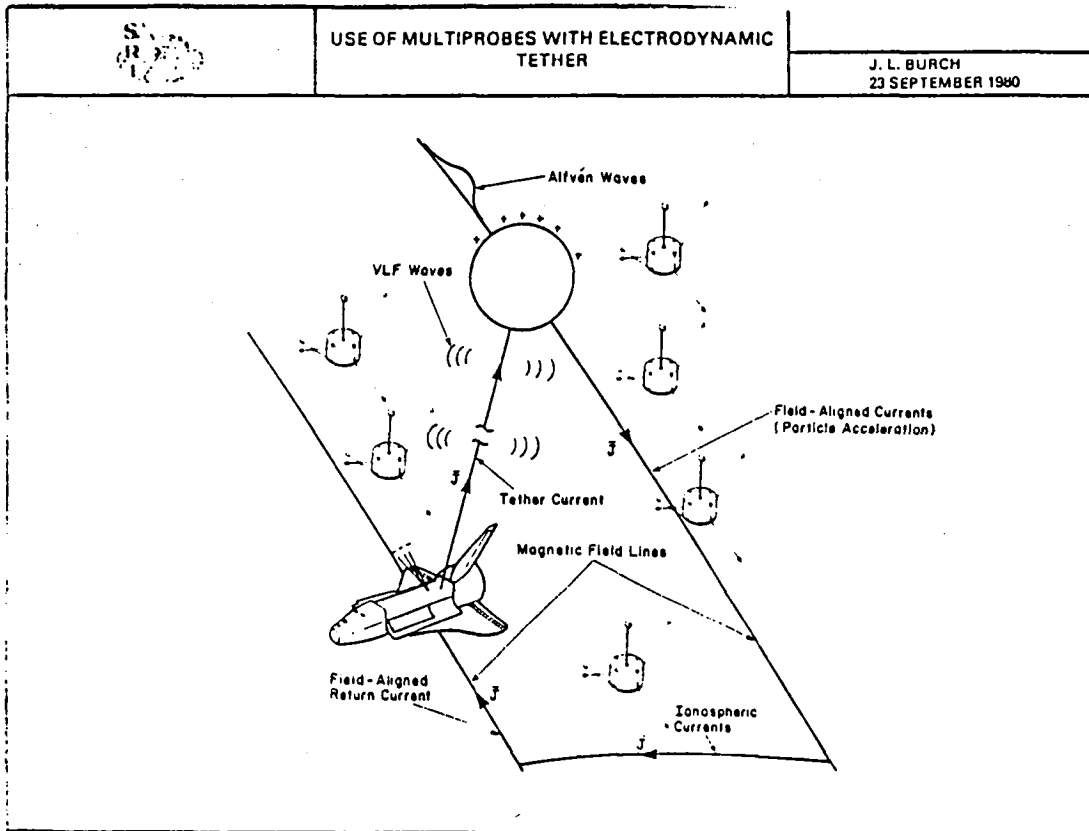
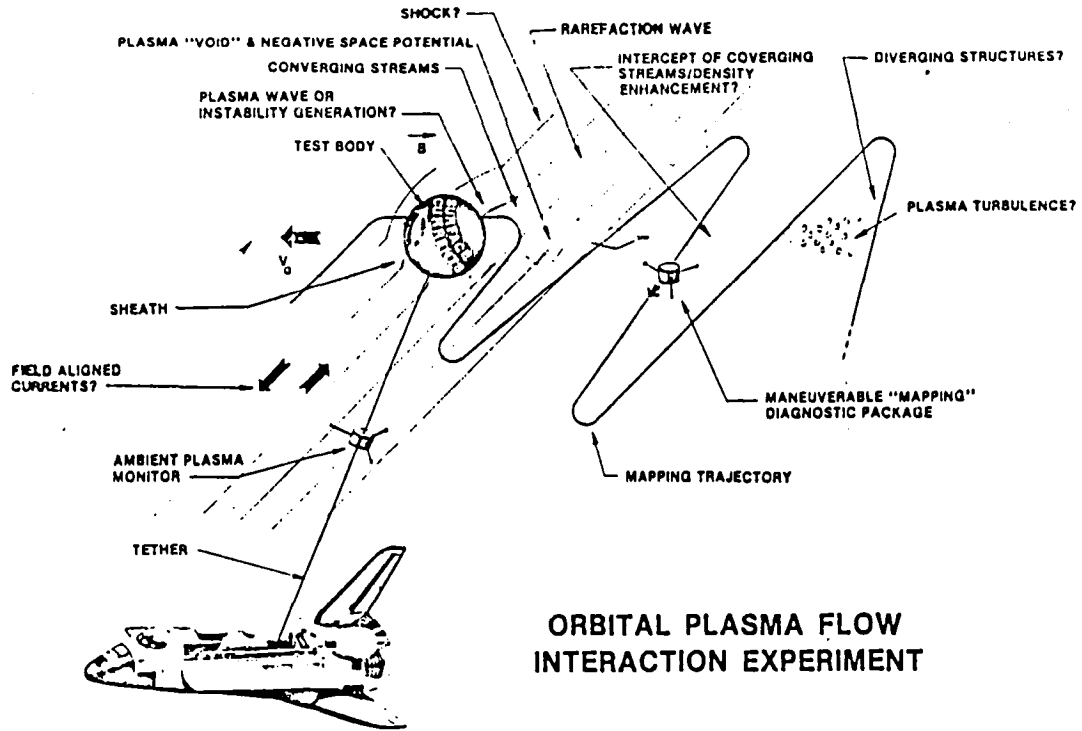

TRANSPORTATION APPLICATIONS I

Joseph Carroll
California Space Institute

The applications of tethers in support of space transportation can be divided into orbit transfer, orbit maintenance, and transfer within constellations. They are entirely different things; however, tethers are attractive in each of these areas.



Which release is optimum, swinging, or hanging?



TRANSPORTATION USES OF TETHERS: AN OVERVIEW

Joe Carroll--California Space Institute

(619) 459-7437

A. ORBIT TRANSFER	B. ORBIT MAINTENANCE	C. WITHIN CONSTELLATIONS
Momentum transfer release/rendezvous: hanging swinging spinning	Electrodynamic thrust in or out of plane, (depending on timing)	Deployment or retrieval of whole constellation
No attitude control system needed to vector the boost	Electrodynamic libration pumping or damping (w/ uneven tip masses)	Clothesline loop
Simplified docking: anywhere on length; "soft" structure	Momentum "scavenging": deboost orbiter & ET	Hoist (w/Coriolis "lag") "Tram" for travel on tether "Monkey" between tethers
	Isolate thruster exhaust from sensitive platforms	Power & fluid transfer

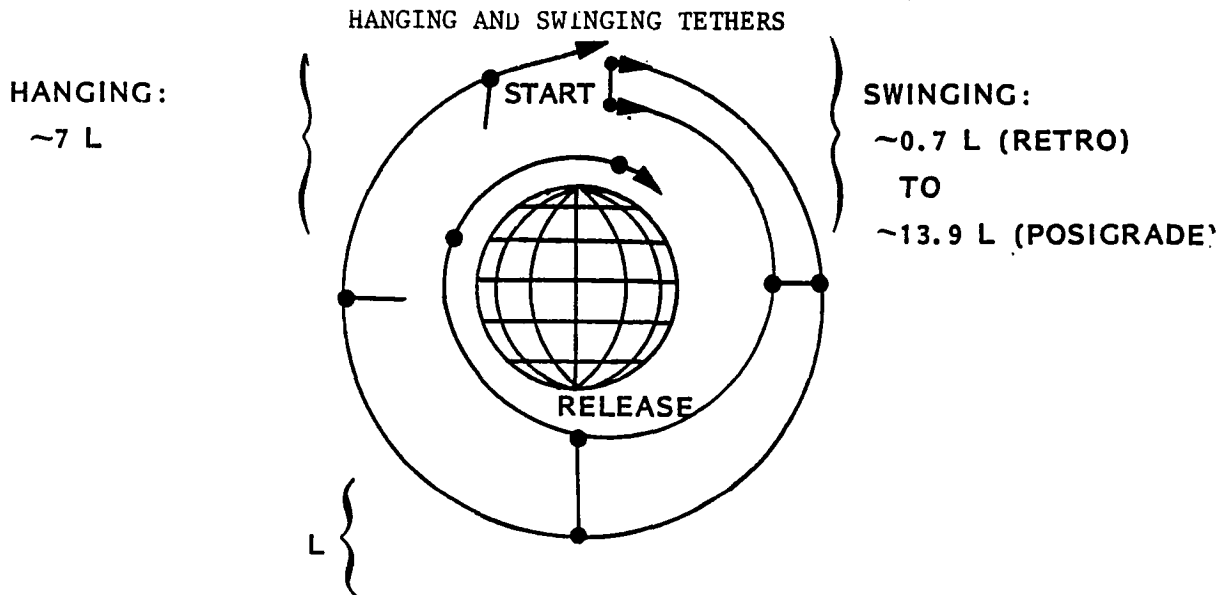

If you buy a system and size it for optimum use in a hanging operation, with the heaviest payload being an orbiter which is to return to the Earth from a space station, then that same piece of hardware will be ideal for swinging releases with somewhat smaller payloads and spinning releases with much smaller payloads.

The other question is how long does it have to be to be useful for momentum transfer applications. 1 km is enough to do some very useful things: contamination control; space station safety. If you go to much longer but still not tapered tethers and the mass of the tether is still small compared to mass of everything else, you can do some very interesting things. A shuttle launch going to a space station can rendezvous at the apogee of an eccentric orbit, saving 6 tons OMS fuel. In going to 300-km tethers, some very radical things happen (payload doubled, orbiter heat load is halved). However, the tether must swing to minimize the period of heavy drag, and the station must be approximately 20 times as massive as the object captured. 

The basic point is that you use the tether in a "flying trapeze" rendezvous. It is a lot easier than one would expect because the relative accelerations are lower than flying trapezes and there are far fewer perturbing forces. 

SOME TETHER SYSTEM DESIGN ISSUES

1. Which is best: to design for hanging, swinging, or spinning?

ALL { Hanging: heavy payloads & low gee-loads
Swinging: medium payloads & low-power retrieval
Spinning: light payloads & high Delta-V.

2. How long does a tether have to be to be useful?

~ 1 km: space station safety & contamination control

~ 60 km: no circularization burn (6 tonnes OMS)

~ 300 km (swinging down to near 100 km):

Launch safety: all debris falls in Atlantic

Delta-V reduction over 1 km/sec: payload DOUBLED

Reentry: integrated orbiter heat load HALVED

MANEUVERING FOR RELIABLE RENDEZVOUS

1. GPS has 2-5 meter RELATIVE position accuracy, SEP.
2. Coarse tuning is best done by vectoring during boost.
3. Last-minute fine-tuning by orbiter RCS or tether-tip thrust.
4. Gravity field may actually simplify the capture hardware:
if desirable, hard docking can be done AFTER capture.

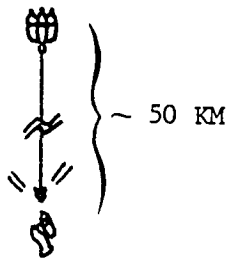

In terms of safety you should look at three different stages during a rendezvous and retrieval of the tether with an orbiter. You can arrange things such that there's no mission failure if the tether breaks at any point in time. What you do is waste fuel. And so you can make it so the tether is mainly used in an energy conservation mode, not to enhance payload but to enhance the amount of fuel which is made available for better use. And then on reentry you can arrange things so that there is nothing jeopardized.

Orbiter safety procedures during rendezvous and release are stated here.



This chart shows the deployment strategy as seen from a fixed orbital reference. If one looks at the strategy shown earlier with a movie camera fixed on the orbit, the ET has this trajectory. The second orbiter Delta-V cushions the end of deployment. The whole thing takes less than 2 hours; 80 minutes for deployment, and 30 minutes to swing to the vertical. This is followed by a pendulum swing.



ORBITER SAFETY DURING RENDEZVOUS & RELEASE

1. For missed rendezvous:

- 1-60 km tether: use OMS fuel intended for use by space station
- 300 km tether: design launch trajectory for safe abort

2. For successful rendezvous:

Mate tether with modified ET nosecone:

ET can support orbiter in 1 gee;

Orbiter safely away from tether & can leave at any time.



3. If tether breaks after rendezvous:

End attached to shuttle boosts shuttle to station.

4. If tether breaks before release:

End attached to shuttle/orbiter deboosts, releases, & reboosts.

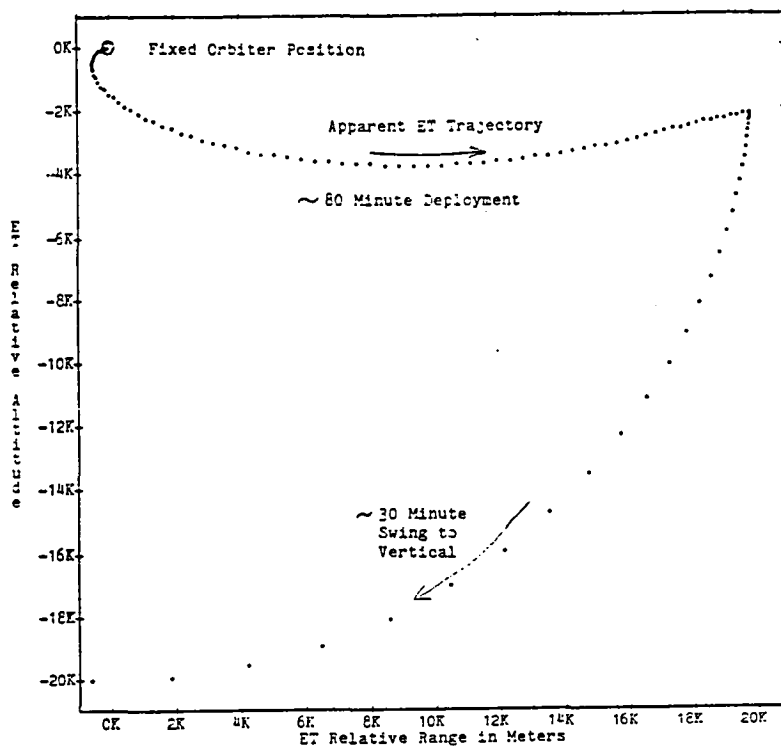

Figure 1. ET Position Relative To Orbiter at One-Minute Intervals

Notes:

- The above figure does NOT show ET inertial position, but ET position relative to the orbiter (which executes two minor RCS maneuvers during deployment).
- Deployment and release operations are as follows:
 - Deployment starts at 10 meter separation with a 1.35 m/s forward RCS burn.
 - Tether tension is actively maintained at 7.5 newtons during deployment.
 - Just before the tether is fully deployed, the orbiter executes a 3 m/s RCS maneuver towards the ET (forward and down), to reduce the deployment rate.
 - The tether remains at full deployed length until release.

This chart shows the deployment velocity over time, the deployed length and the tension which is 7.5 newtons (1.5-2 lb). There is tension all during deployment because the deployment velocity is always positive, a simple braking device can provide tension.

There is a nearly horizontal deployment strategy. What that does compared to a slow deployment is reduce the power that has to be absorbed by the reel brake by a factor of 500. That has to do with the fact that if you can use a shorter tether there is a squared tether length effect. Tension is further reduced by a factor equal to the square of the cosine of the deployment angle. With the radical simplification of your power-dissipating hardware for this sort of operation you can make the deployer much simpler.



This chart points to other possible future tether applications.



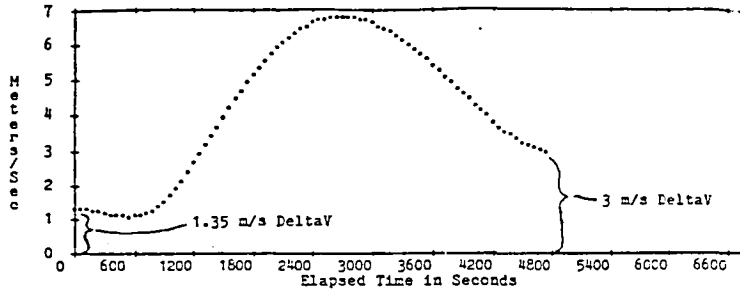

Figure 2. Tether Deployment Rate vs Time

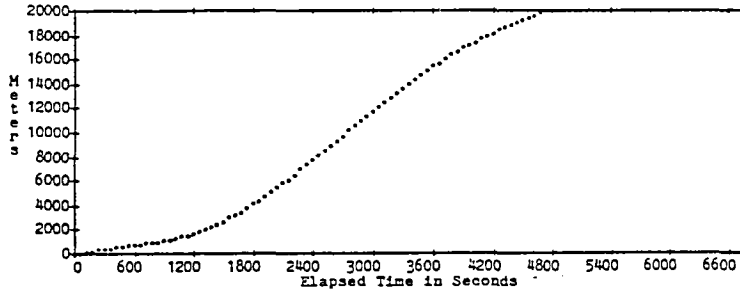

Figure 3. Deployed Tether Length vs Time

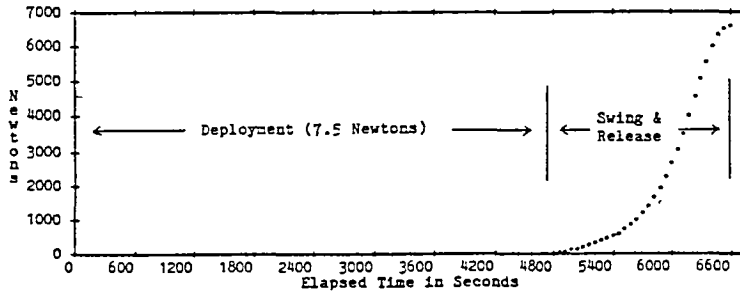
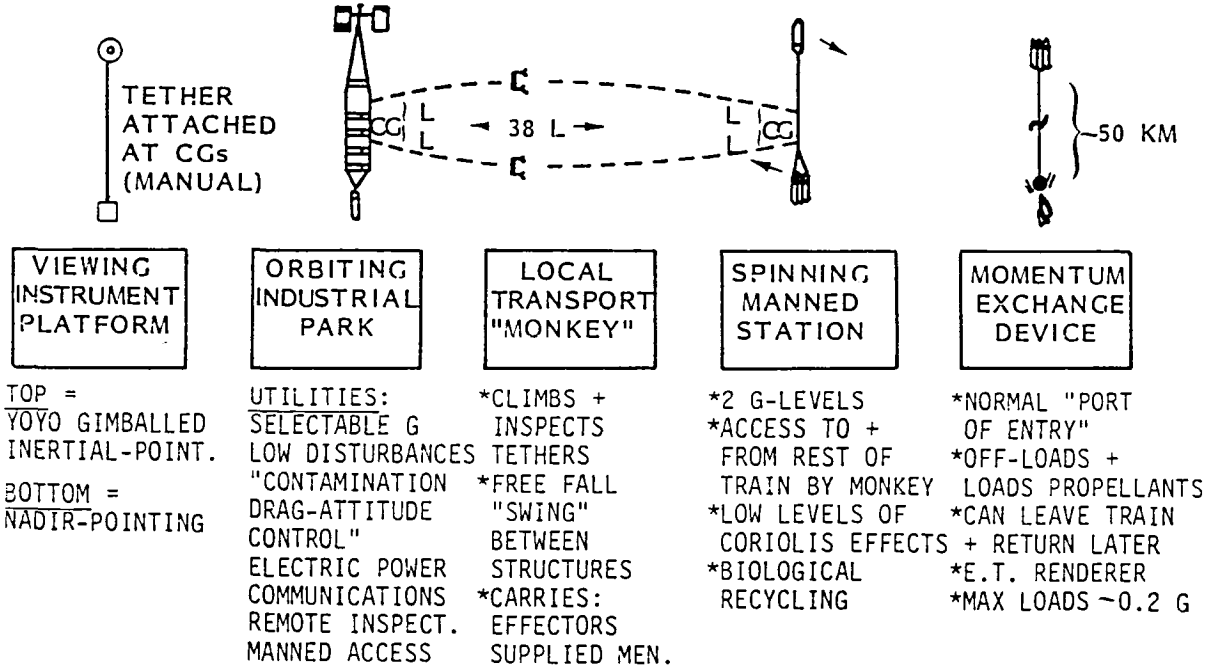

Figure 4. Tether Tension vs Time

A SPACE STATION "TRAIN" OR "PARADE"
(An Untethered Train of Tethered Structures)



This chart describes design and mission concepts for a simple free-flying electrodynamics experiment.



CONCEPT FOR A SIMPLE FREE-FLYING ELECTRODYNAMICS EXPERIMENT

Design Concept:

GPS translators at each tip relay their positions to ground.
Electric power comes from the tether and is monitored/controlled.

Mission Concept:

Deploy system from orbiter with TSS hardware.
Release system into fairly high orbit from eccentric STS orbit.
After separation, monitor remote ionospheric effects w/ orbiter.
From ground: monitor orbital decay and power output vs altitude.
modulate power for electrodynamic libration control.

TRANSPORTATION APPLICATIONS II

Enrico Lorenzini
Aeritalia

Tether applications look promising in the areas of payload transfer, reentry, rendezvous, and docking and orbit modification by tether control.



These applications can be exploited by a single specialized subsatellite called the Tether Teleoperator Maneuvering System (TTMS).



GENERAL CONSIDERATIONS

- . TETHERS ARE CANDIDATES FOR MANY INTERESTING TRANSPORTATION APPLICATIONS :
- . PAYLOADS TRANSFER TO HIGHER OR LOWER ENERGY ORBITS.
- . REENTRY
- . RENDEZ-VOUS AND DOCKING.
- . ORBIT MODIFICATION BY TETHER CONTROL.

TETHER TELEOPERATOR MANOEUVERING SYSTEM (TTMS) APPLICATIONS

- . AT THE PRESENT STAGE A STANDARD TELEOPERATOR IS A SPACE VEHICLE FOR PLACING, RETRIEVING AND SERVICING OTHER SPACECRAFTS.
- . A TETHERED TELEOPERATOR CAN ADD INTERESTING FEATURES TO THE STANDARD TELEOPERATOR CAPABILITIES.
- . TETHERED TELEOPERATOR PERFORMANCE MUST BE INVESTIGATED IN THE FOLLOWING AREAS :
 - . DEPLOYMENT AND RETRIEVAL OF THE TTMS.
 - . PAYLOAD TRANSFER
 - . REENTRY
 - . RENDEZ-VOUS AND DOCKING.

The expected advantages of the TTMS in the areas of payload transfer, rendezvous and docking and reentry are outlined here. The next several charts discuss a series of work statement tasks to examine the applicability of TSS and TTMS concepts to NASA Space Stations.



General guidelines for a TSS concept study of future applications to NASA Space Stations.



TETHERED TELEOPERATOR MANEUVERING SYSTEM EXPECTED PERFORMANCE

- o PAYLOAD TRANSFER
 - . PROVIDE AN ALTERNATIVE SOLUTION TO ORBIT TRANSFER PROBLEMS
 - . POSSIBLE INCREASE IN LAUNCHING CAPABILITY CONSIDERING THE OVERALL STRATEGY OF THE MISSION.
 - o RENDEZ-VOUS AND DOCKING
 - . REDUCE THE PERTURBATIONS ON LARGE BODY STRUCTURES (E.G. S/S) BY MEANS OF THE TETHER MEDIATION.
 - . EXPEDITE THE RENDEZ-VOUS AND DOCKING MANOEUVRES.
 - o REENTRY
 - . REDUCE THE REENTRY VELOCITY OF REENTRY SPACECRAFTS.
-

TSS CONCEPT FUTURE APPLICATIONS TO NASA SPACE STATIONS

STUDY GENERAL GUIDELINES

WORK STATEMENT. TASKS.

1. ASSESS IF MAJOR WEAKNESSES EXIST WHICH PREVENT THE CONTINUATION OF THE STUDY
2. PROVIDE THE RESULTS IN PARAMETRIC FORM VERSUS THE MAIN PARAMETER VARIATIONS IF THE FIRST POINT IS OVERTAKEN
3. PERFORM SOME PRELIMINARY COMPARISON EVALUATIONS WITH EXISTING SOLUTIONS.

Work statement tasks for examining the TTMS concept.



Work statement tasks examining TSS Deployment and Retrieval.



TSS CONCEPT FUTURE APPLICATIONS TO NASA SPACE STATIONS

TETHERED TELEOPERATOR MANOEUVERING SYSTEM (TTMS)

WORK STATEMENT. TASKS.

1. INVESTIGATE ALTERNATIVE PROPOSALS FOR THE TTMS CONTROL SYSTEM.
 2. ANALYZE THE JOINT TTMS CONTROL BY TETHER AND AUTONOMOUS TTMS CONTROL SYSTEM.
 3. EVALUATE THE MANOEUVERABILITY PERFORMANCE.
 4. VERIFY THE MANOEUVRE TIMES AND THE STATION-KEEPING AUTONOMY VERSUS OUT-OF-VERTICAL POSITIONS REACHED.
 5. EVALUATE THE ENERGY CONSUMPTION FOR THE MANOEUVERS AND THE STATION-KEEPING.
-

TSS CONCEPT FUTURE APPLICATIONS TO NASA SPACE STATIONS

DEPLOYMENT AND RETRIEVAL

WORK STATEMENT. TASKS

1. INVESTIGATE SUITABLE CONTROL LAWS FOR THE DEPLOYMENT, RETRIEVAL, STATION-KEEPING PHASES.
2. PROPOSE SOLUTIONS AND INVESTIGATE THE PERFORMANCE OF THE TTMS CONTROL SYSTEM IF ACTIVELY CONTROLLED.
3. EVALUATE THE ENERGY REQUIRED OR THE PROPELLANT CONSUMED BY THE TTMS CONTROL SYSTEM.
4. EVALUATE THE TETHER CHARACTERISTICS: MATERIALS, MASS, SHAPE, DIAMETERS, ETC.
5. EVALUATE THE POWER REQUIRED BY THE REEL MOTOR.
6. EVALUATE THE RETRIEVAL DYNAMICS IN THE CASE OF LARGE BOTH IN-PLANE AND OUT-OF-PLANE INITIAL ANGULAR VALUES RELEVANT TO A RECOVERY OF A TETHERED TELEOPERATOR IF A FAILURE OF THE ACTIVE CONTROL SYSTEM HAS OCCURRED.

Work statement tasks for payload transfer to higher or lower energy orbits and reentry.



A continuation of Payload Transfer Tasks.



TSS CONCEPT FUTURE APPLICATIONS TO NASA SPACE STATIONS

PAYLOAD TRANSFER TO HIGHER OR LOWER ENERGY ORBITS AND REENTRY

WORK STATEMENT. TASKS.

1. DETERMINATION OF THE RANGE OF ORBITS THAT CAN BE ACHIEVED AS A FUNCTION OF TETHER LENGTH BOTH IN THE CASE OF A HANGING AND SWINGING TETHER. INITIAL CONDITIONS ARE THE POSITION AND VELOCITY OF THE SUBSATELLITE AT THE MOMENT OF RELEASE.
 2. INVESTIGATION OF THE CONTROL STRATEGIES ALLOWING TO REACH THE ENVISAGED INITIAL CONDITIONS. DETERMINATION OF CONSTRAINTS ARISING FROM DEPLOYMENT/RETRIEVAL REQUIREMENTS.
 3. EFFECTS OF THE RELEASE OF PAYLOAD ON THE ORBIT OF THE MAIN STATION. OPTIMIZATION OF THE STRATEGY OF MANOEUVRES WITH REGARD TO THE STATION-KEEPING OF THE PLATFORM.
 4. BEHAVIOUR OF THE TENSION OF THE TETHER AFTER PAYLOAD RELEASE.
-

TSS CONCEPT FUTURE APPLICATIONS TO NASA SPACE STATIONS

5. EVALUATION OF THE UNCERTAINTY IN ACHIEVING THE DESIRED INITIAL CONDITIONS FOR PAYLOAD RELEASE DUE TO THE BEHAVIOUR OF THE TETHERED SYSTEM. SENSITIVITY ANALYSIS WITH REGARD TO THE ELEMENTS OF THE TRANSFER ORBIT.
6. SINGLE OUT AND ANALYZE POSSIBLE STRATEGIES FOR A TETHER INITIATED REENTRY.

Tasks for rendezvous and docking.



The most important point for rendezvous is to reduce the perturbation on the large body structure by means of tether mediation. Controlling the tension in the tether keeps the perturbations at the desired level and expedites the rendezvous. Consider an approaching spacecraft in an elliptic orbit. The relative velocity with respect to the docking probe is going to decrease and in a theoretical condition is zero at the point where the apogee of the orbits meet. A very fast rendezvous and docking with the spacecraft can be accomplished if the length of the tether is the appropriate one. In the general condition you have to swing the satellite to control the docking probe to follow or to mesh with the approaching spacecraft. For reentry the important point is the velocity. By resorting to the tether you reduce the initial velocity of the reentry spacecraft so that velocity in the upper layer of the atmosphere is reduced.



TSS CONCEPT FUTURE APPLICATIONS TO NASA SPACE STATIONS

RENDEZ-VOUS AND DOCKING

WORK STATEMENT. TASKS.

1. INVESTIGATION ON THE TIME CONSTRAINTS AND THE RELATIVE VELOCITY VARIATION DURING THE CLOSE APPROACH FOR DIFFERENT TRANSFER ORBITS (DIFFERENT TETHER LENGTHS)
2. ANALYSIS OF THE EFFECT OF THE ORBIT PARAMETERS DISPERSION ON THE RENDEZ-VOUS.
3. INVESTIGATE THE NEED FOR A GOOD MANOEUVERABILITY OF THE DOCKING PROBE TO INCREASE THE RENDEZ-VOUS SUCCESS.
4. EVALUATION OF THE ORBIT AND ATTITUDE PERTURBATIONS OF THE SYSTEM AFTER DOCKING.

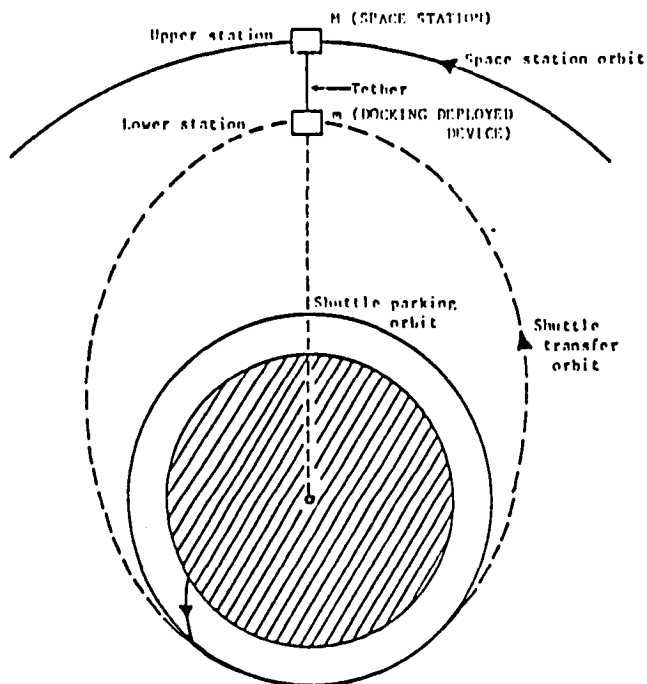

The relative velocity δ for docking and the geometry of the rendezvous are shown.



The present status of a study of stationkeeping and orbit parameters modification is outlined.



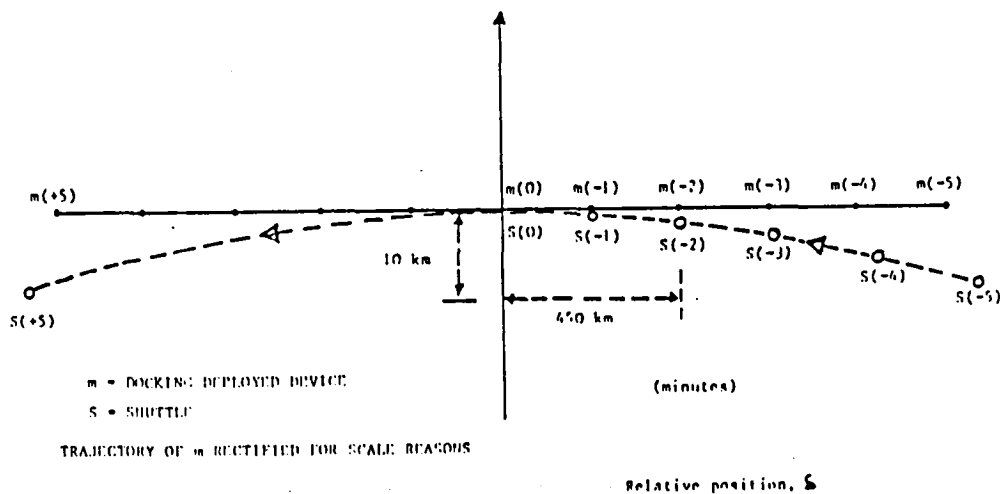
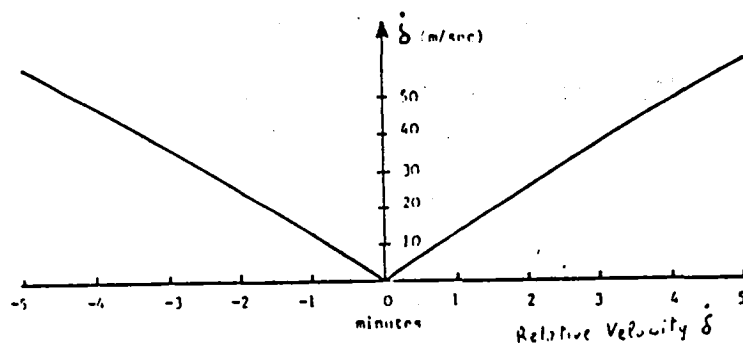

STATION KEEPING AND ORBIT PARAMETERS MODIFICATION
(GENERAL CONSIDERATIONS AND PRESENT STATUS)

- 0 SCOPE
 - . INVESTIGATE THE POSSIBILITY TO MODIFY THE ORBIT PARAMETERS BY INCREASING THE TOTAL ENERGY OF THE SYSTEM BY SUITED LENGTH CONTROL OF THE TETHER.
- 0 AN EXAMPLE
 - . THE TETHER OF A TETHERED SS FOLLOWING AN ELLIPTICAL ORBIT CAN BE LENGTHENED AT THE APOGEE AND SHORTENED AT THE PERIGEE OF THE SAME AMOUNT PRODUCING A TOTAL ENERGY INCREASE OF THE SYSTEM. CONSEQUENTLY THE ECCENTRICITY INCREASES.
 - . THIS STRATEGY COULD PROVIDE AN ALTERNATIVE SOLUTION TO COUNTERACT THE AERODYNAMIC EFFECT OF THE SS WHICH REDUCES THE ORBITAL ECCENTRICITY.
- 0 PRESENT STATUS
 - . THE SOLUTION IS NOW CONSIDERED LITTLE PROMISING.
 - . ORBIT ECCENTRICITY INCREASE WITH BOTH APOGEE INCREASE AND PERIGEE DECREASE SEEMS TO BE ACHIEVABLE ONLY.

The energy pumping system is illustrated.



This chart shows a logical development of the present TSS. This development would make some tests with a shuttle and a modification of a present TSS. The launch system is obtained by the minor modification to our service model of a TSS adding some grabbing device so to investigate the area of payload transfer in this case from the shuttle. It can be an interesting approach of a problem that we have in hand today. With major modification of a subsatellite by a present deployer, we could perform some tests on the rendezvous and docking with a shuttle and this sort of docking probe. These things go together for the creation in the future of a TTMS which should be a larger subsatellite capable of performing all these missions from a space station.



Energy Pumping Example

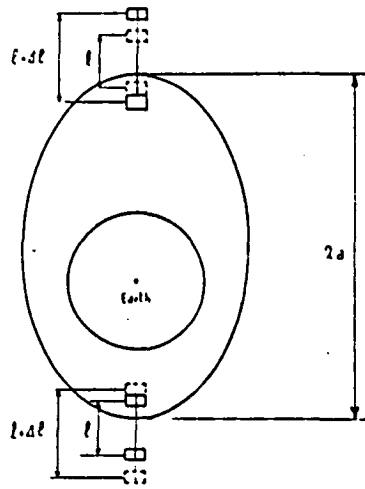

$$\text{Energy} = - \frac{K}{2a} \quad (\text{increase by pumping})$$

$$\text{Angular Momentum} = \sqrt{K a (1 - e^2)} = \text{const.}$$

Results:

- a . Increase
- e . increase
- a (1 + e) increase (apogee)

T S S CONCEPT EVOLUTION

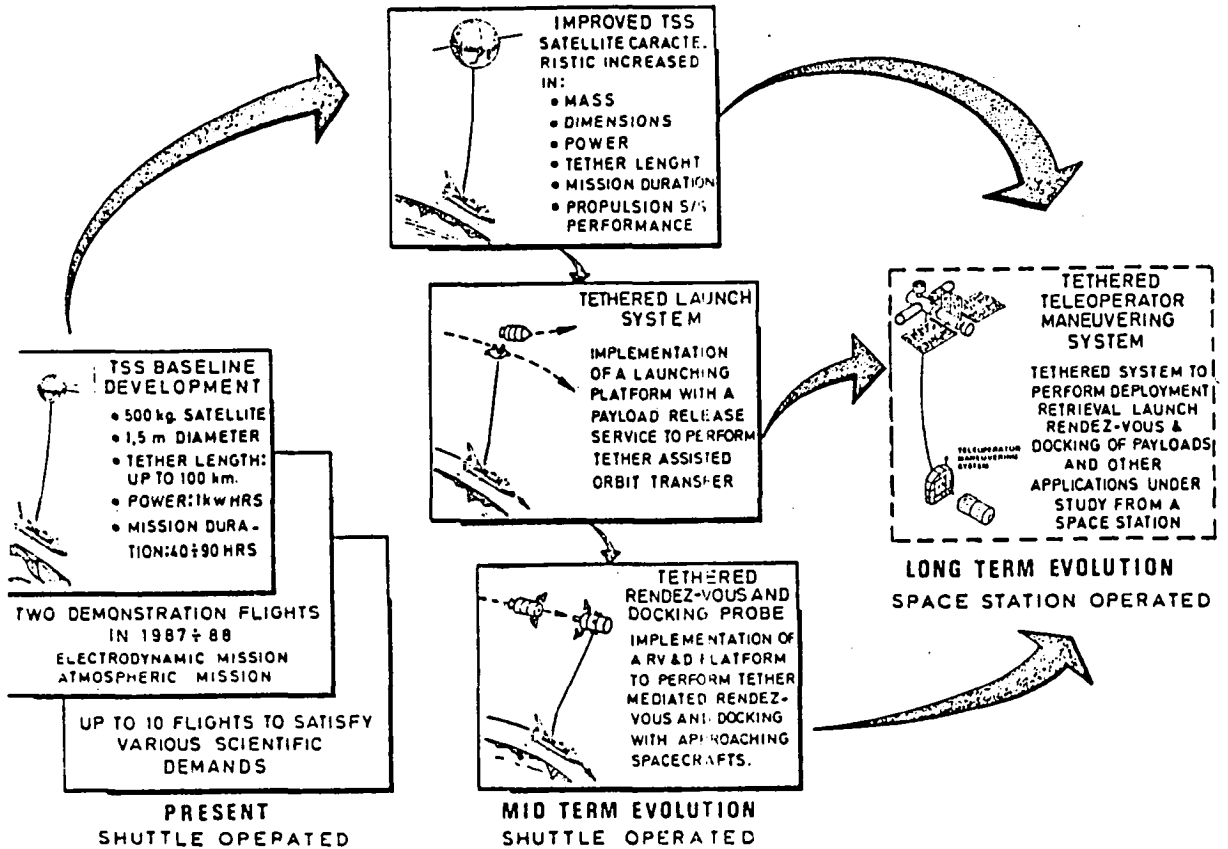

PHYSIOLOGICAL CONSIDERATIONS
OF
ARTIFICIAL GRAVITY

D. Bryant Cramer
NASA Headquarters

This chart suggests answers to the question as to why we might need artificial gravity.



This is a list of the generic aspects of what to worry about in terms of any organ system that is affected by weightlessness. 3 systems are clearly involved: cardiovascular, skeletal, vertibular.



ARTIFICIAL GRAVITY – WHY MIGHT WE NEED IT?

- **WEIGHTLESSNESS PRODUCES SIGNIFICANT PHYSIOLOGICAL CHANGES:**
 - THE MECHANISMS ARE NOT WELL UNDERSTOOD
 - WHETHER THESE CHANGES WILL STABILIZE OR PROGRESS TO PATHOLOGICAL STATES IS NOT KNOWN
 - WITH CURRENT COUNTERMEASURES, WE ARE PROBABLY SAFE TO SIX MONTHS' EXPOSURE
 - THE POINT AT WHICH RAPID READAPTATION TO EARTH GRAVITY BECOMES COMPROMISED IS PRESENTLY UNKNOWN
 - THERE IS MUCH WE NEED TO LEARN
 - A SPACE STATION IS THE IDEAL LABORATORY FOR STUDYING THE PHYSIOLOGICAL EFFECTS OF WEIGHTLESSNESS
 - **AS OUR CURRENT COUNTERMEASURES CONSUME AN EVER INCREASING PORTION OF AVAILABLE CREW TIME, MORE EFFICIENT ALTERNATIVES BECOME NECESSARY**
 - **ARTIFICIAL GRAVITY IS THE MOST "NATURAL" COUNTERMEASURE**
-

ARTIFICIAL GRAVITY – PHYSIOLOGICAL ISSUES

- **GENERIC ISSUES:**
 - ACUTE EFFECTS
 - NEW SET POINTS IN WEIGHTLESSNESS
 - STABILIZED STATE ALOFT
 - CAPACITY FOR RAPID READAPTATION TO EARTH GRAVITY
 - ROLE OF WEIGHTLESSNESS IN THE DEVELOPING INDIVIDUAL
 - EFFECTS OF ARTIFICIAL GRAVITY—HOW MUCH? HOW LONG?
- **THREE ORGAN SYSTEMS ARE KNOWN TO BE GRAVITY SENSITIVE:**
 - CARDIOVASCULAR
 - SKELETAL
 - VESTIBULAR

Systems in the cardiovascular, skeletal and vestibular categories which are affected by artificial gravity.



Two options for artificial gravity exist: small radii, high angular velocity (large torus) and large radii, low angular velocity (tether).



ARTIFICIAL GRAVITY—AFFECTED SYSTEMS

- **CARDIOVASCULAR:**
 - ORTHOSTATIC GRADIENTS
 - ACUTE FLUID SHIFTS
 - ORTHOSTATIC INTOLERANCE
 - COUNTERMEASURES:
 - “G” SUITS
 - LOWER BODY NEGATIVE PRESSURE
 - SALT LOADING/DRUGS
 - EARLY DEVELOPMENT

 - **SKELETAL:**
 - PERSISTENT LOSS
 - LOAD BEARING BONES
 - IRREVERSIBILITY
 - COUNTERMEASURES:
 - SKELETAL LOADING
 - DRUGS
 - EARLY DEVELOPMENT

 - **VESTIBULAR:**
 - SPACE SICKNESS
 - ILLUSIONS
 - COUNTERMEASURES:
 - DRUGS
 - ADAPTATION
 - BIOFEEDBACK
 - EARLY DEVELOPMENT
-

ARTIFICIAL GRAVITY — OPTIONS

- **EARLIER DESIGNS EMPLOYED A LARGE TORUS:**
 - RELATIVELY SMALL RADII
 - HIGH INCIDENCE OF MOTION SICKNESS
 - HIGH CORIOLIS ACCELERATIONS

- **TETHER-BASED DESIGNS PROMISE NEW OPPORTUNITIES:**
 - LARGE RADII
 - IT ROTATES—BUT SLOWLY
 - LOW INCIDENCE OF MOTION SICKNESS
 - LOW CORIOLIS ACCELERATIONS
 - VERY LOW “G” GRADIENTS

Parameter limits involved in artificial gravity.



This chart shows the angular velocity, centripetal acceleration, and radii in feet for artificial gravity parameters. Bounded by the coriolis limit, the tractor limit, the tether mass limit, and motion sickness limit are earth gravity as noted in the middle of the figure.



ARTIFICIAL GRAVITY— PARAMETERS

- UNAIDED TRACTION REQUIRES 0.1 G
- ANGULAR VELOCITY SHOULD BE LESS THAN 3.0 RPM TO AVOID MOTION SICKNESS
- MAXIMAL CENTRIPETAL ACCELERATION NEED NOT EXCEED EARTH GRAVITY
- CORIOLIS ACCELERATION SHOULD NOT EXCEED 0.25 CENTRIPETAL ACCELERATION FOR A LINEAR VELOCITY OF 3 FEET/SECOND IN A RADIAL DIRECTION
- "G" GRADIENT SHOULD NOT EXCEED 0.01 G/FOOT IN RADIAL DIRECTION
- TETHER MASS MIGHT BE LIMITED TO 10,000 TO 20,000 POUNDS

ARTIFICIAL GRAVITY PARAMETERS

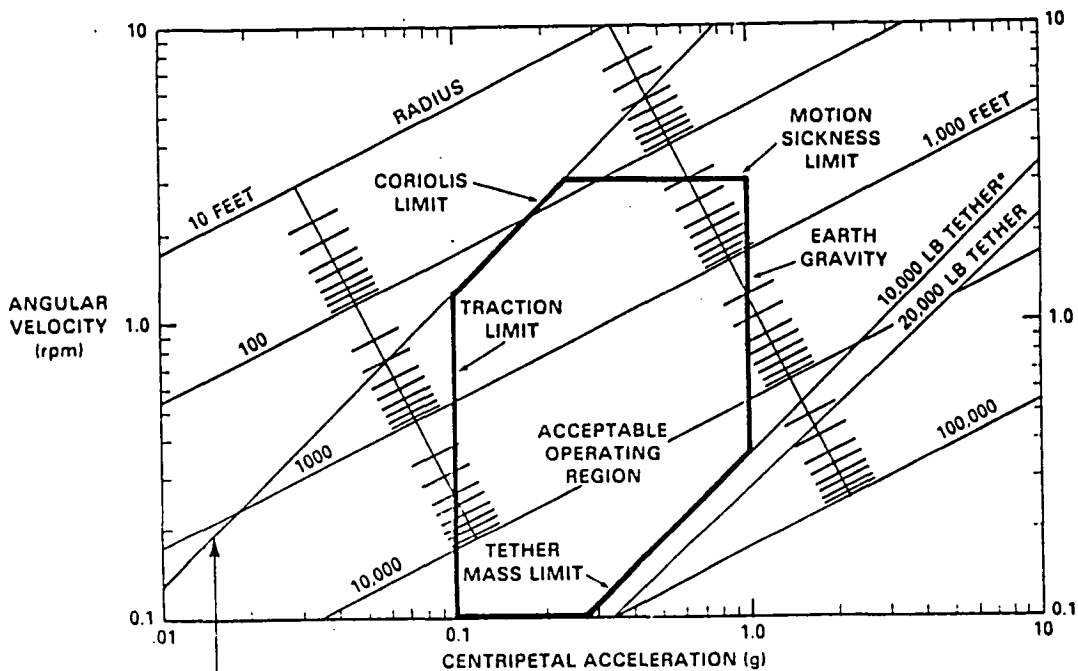

CORIOLIS ACCELERATION = 0.25 CENTRIPETAL ACCELERATION
FOR 3 FT SEC⁻¹ RADIAL VELOCITY

• TETHER MASS LIMIT:
100,000 LB MODULE AT EACH END,
KEVLAR, CYLINDRICAL TETHER

This chart shows how to approach a study of artificial gravity, obtain promising hypotheses by evaluating, and in each case working out objective criteria for evaluating. Two avenues are there - spacelab and space station.



This chart suggests artificial gravity alternatives. If it turns out that fractional G for a long period of time is really what we need (remember going back to the individual organ systems) then artificial gravity makes sense.



ARTIFICIAL GRAVITY— STUDY APPROACH

GROUND-BASED LABORATORY

- SIMULATED WEIGHTLESS EXPOSURE
 - BED REST
 - WATER IMMERSION
- RECONDITIONING STIMULI
 - INCLINED PLANE
 - CENTRIFUGE
 - ALTERNATIVE COUNTERMEASURES



STS SPACELAB

- ACUTE EFFECTS OF WEIGHTLESSNESS
- VALIDATE ANIMAL MODELS
- IMPROVE CURRENT COUNTERMEASURES



SPACE STATION

- CHRONIC EFFECTS OF WEIGHTLESSNESS (ANIMALS)
- VALIDATE MODELS IN HUMANS
- DEVELOP SECOND GENERATION COUNTERMEASURES
- BASIC RESEARCH IN GRAVITATIONAL BIOLOGY

ARTIFICIAL GRAVITY— ALTERNATIVES

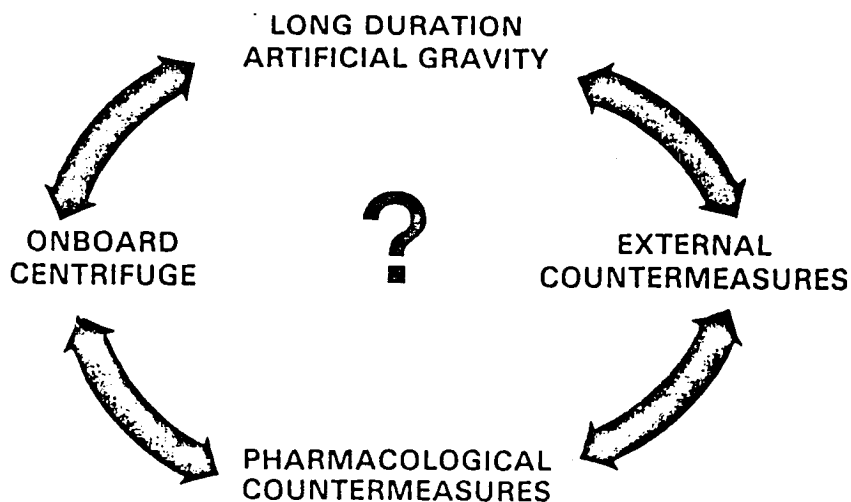

This chart suggests that as far as the ground based centrifuge is concerned, something is needed that can explore a rich variety of fractional gravity. What one has to do is have tethers that hold this guy up here to the ceiling. He's in slings down here. Notice that the long axis of the cardiovascular system, in fact, is null to gravity but in line with the centripetal acceleration of the centrifuge. Down here it may be wise to have scales or a treadmill or some other device.



This chart shows a cheaper alternative way of doing it is just to use an inclined plane. NASA did a great deal of this work back in mid-late 60s. There is still a large lunar simulation at Langley.



ARTIFICIAL GRAVITY — GROUND-BASED CENTRIFUGE

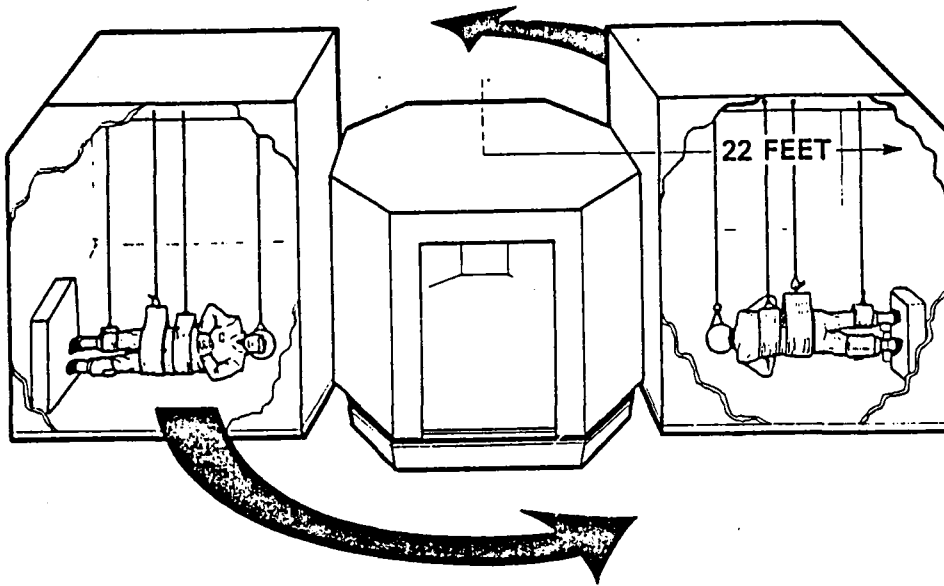

ARTIFICIAL GRAVITY — INCLINED PLANE

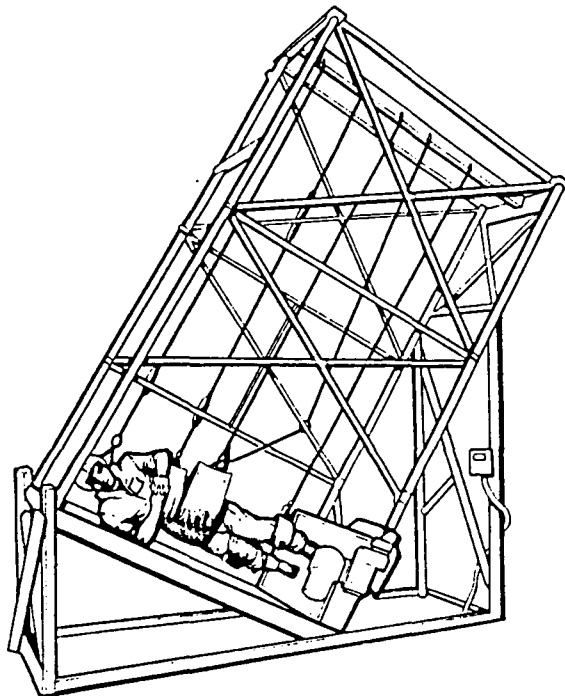

This chart illustrates a spacelab can and a kind of centrifuge you could put in there that would allow you to position man in different ways and using this kind of device validate whatever you wanted to look at regarding large amounts of acceleration for short period times in the space environment.



This chart summarizes artificial gravity knowledge.



ARTIFICIAL GRAVITY— SPACE-BASED CENTRIFUGE

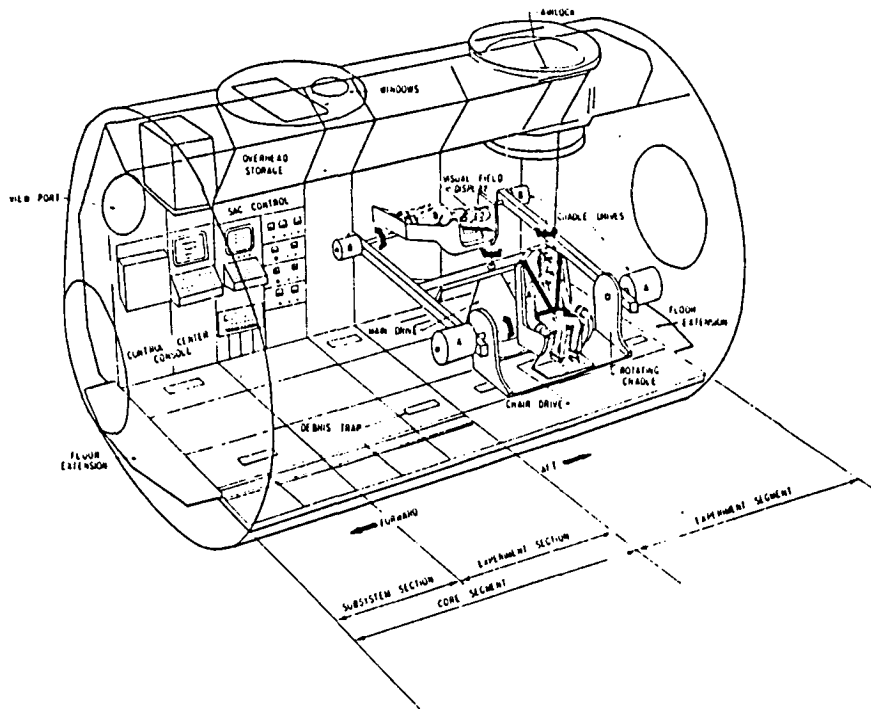

ARTIFICIAL GRAVITY—SUMMARY

- WEIGHTLESSNESS PRODUCES SIGNIFICANT PHYSIOLOGICAL CHANGES
- WHETHER THESE CHANGES WILL STABILIZE OR ACHIEVE MEDICAL SIGNIFICANCE IS NOT YET CLEAR
- ARTIFICIAL GRAVITY IS THE MOST PHYSIOLOGICAL COUNTERMEASURE
- TETHER SYSTEMS REPRESENT AN ATTRACTIVE APPROACH TO ARTIFICIAL GRAVITY
- MUCH MORE RESEARCH IS NECESSARY TO EVALUATE THE NEED FOR ARTIFICIAL GRAVITY

CONSTELLATIONS

David R. Criswell
California Space Institute

This chart reminds us that spacecraft design has been undergoing an evolution. It traditionally started with individual spacecraft and the various functions. Right now we are more or less at the peak of multifunction spacecraft. We have a lot of things going on all in the same unit. In the future, there will be space platforms such as the space station that will do a great many functions. One of the main challenges we've got coming up is how to create increasing opportunities to lower costs for various operations in space and what's being explored here are two rather specifically. The free swarm, and the tethered swarm. In the case of the free swarm, the perturbations which accumulate from the various satellites become less interdependent. Large Delta-Vs might be possible depending on the orbits you run into. On the other hand with tethers, you might have a common service area, a physical tether, a large number of satellites. There you'll have to worry about how you build your tether--by strings, by trusses, by forces, by drag. You have the ballistic coefficient, area, altitude and solar cycle or dynamic trusses.



We have experience with free-flying systems. The global positioning system is an example of this. Tracking data relay satellites are another. We might even have systems in counter-rotating polar orbits such that one could have things thrown out from them at the right time and have very high impact velocity experiments done perhaps over the Arctic and Antarctic and recover some of the fragments of collision.



Multi-Service Space Platforms and Swarms

INDIVIDUAL SPACECRAFT
SINGLE FUNCTION ① ② ③ ... ④

MULTIFUNCTION SPACECRAFT

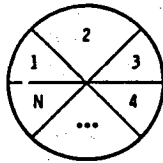

MULTI-SERVICE SPACE PLATFORM

CHALLENGE
CREATE INCREASING
OPPORTUNITIES AND
LOWER UNIT COSTS

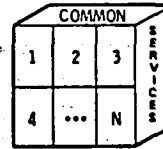

TETHERED SWARM

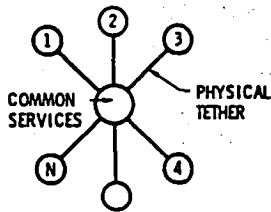

FREE SWARM

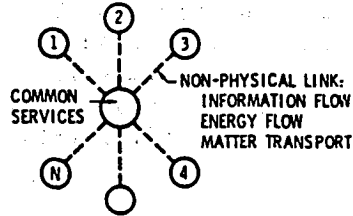

- TETHERS, TRUSSES, E-M FORCES, DRAG ($M^2, KG/M^2$, ALTITUDE; SOLAR CYCLE), DYNAMIC TRUSSES (IN & OUT OF PLANE), THRUSTING (ION, CHEMICAL, MASS DRIVER..), MAGNETS.
- CRAWL, HOP, FLING OR FLY BETWEEN UNITS
- REARRANGE UNITS, ADD, SUBTRACT, ISOLATE, CONNECT
- OUTWARD AND INWARD TRANSPORT

- INTERMITTANT CONTACTS
- PERTURBATIONS ACCUMULATE
- LESS INTERDEPENDENT, DISTRIBUTED COOPERATION
- LARGE DELTA-V POSSIBLE

FREE FLYERS EXAMPLES

- GLOBAL POSITIONING SATELLITES (GPS)*
- TRACKING AND DATA RELAY SATELLITES (TDRS)*
- MOTHER-DAUGHTER SCIENCE SYSTEMS (EX. MAGNETOSPHERE EXPLORERS)*, STIMULATION EXPERIMENTS (PLASMA RELEASE,..)
- DRAG OFF-SET ENCLOSED TEST MASSES*

PROPOSED

- LASER (HIGH) & MICROWAVE (LOW) COMMUNICATION SYSTEMS
- MICROWAVE & LASER BEAM REFLECTORS (EHRICKE, ROGERS,..)
- SPACE SOLAR POWER SATELLITES
- EARTH-MOON (PHASE LOCKED, OPERATIONAL)
- ASTRONOMICAL SYSTEMS (INTERFEROMETERS, FRESNEL ZONE PLATES,..)
- PARTICLE ACCELERATOR RING (HIGH ENERGY BEAMS, CIRCUM-EARTH)
- SOLETTAS OR LUNETTAS
- OCCULTORS (E-M, PARTICLES,..)
- ULTRA HIGH ENERGY (LONG LIVED) PARTICLE OBSERVATORIES
- EARTH OBSERVATION PAIRS
 - UPPER ATMOSPHERE (ACTIVE)
 - OCEAN/EARTH GRAZING RADAR
- COUNTER ORBITING IMPACTS FACILITIES
- DISTRIBUTED PHASED RADIO ARRAYS
- STAGED (ENERGY, MOMENTUMS BANKING) TRANSPORTATION SYSTEMS

This is essentially to remind you in a cartoon fashion of a 1-D tether configuration potpourri of possible things that could be done. It is important to remember that when we talk about tethers providing an opportunity for access to milli-G levels either directed toward earth or out away from earth that you still have a center of mass point which is at 0 G. It is really not a matter of buying one or the other. You actually can buy a range of different things. You can lower probes into the ionosphere as suggested. Jerome Pearson has a very nice idea about lowering high temperature cells into the upper atmosphere and using them to plane change so as to minimize reaction mass. You have this possibility with these 1-D systems of launching satellites to higher altitudes and perhaps large separation of your power plant mass from the major users.



It is important to remember the possibility of booms being employed in various components of the system so that you have static separation elements simply using booms that you can imagine being built now. There is a second aspect of this particular approach to booms. That is the access to experiments deployed along the 1-D axis. In effect you would not really like to have to climb around every experiment to access one or to have to pull them all in to get at one. One reason for proposing a boom deployed from the central service area is that you could have a crawler or something like that so that you could go out one free element and go across and repair or replace whatever is on your main experiment line. There are other ways to do this if this boom were very long or else if you had a long set of tethers.



1-D TETHER POTPOURRI

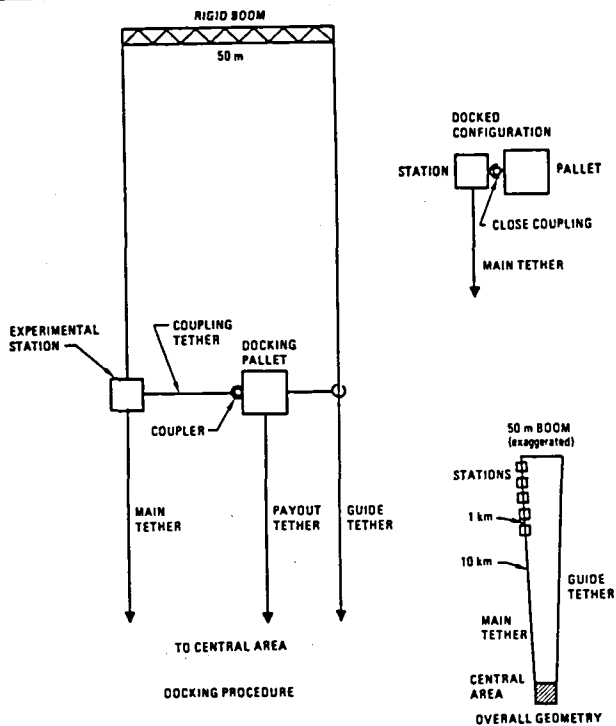
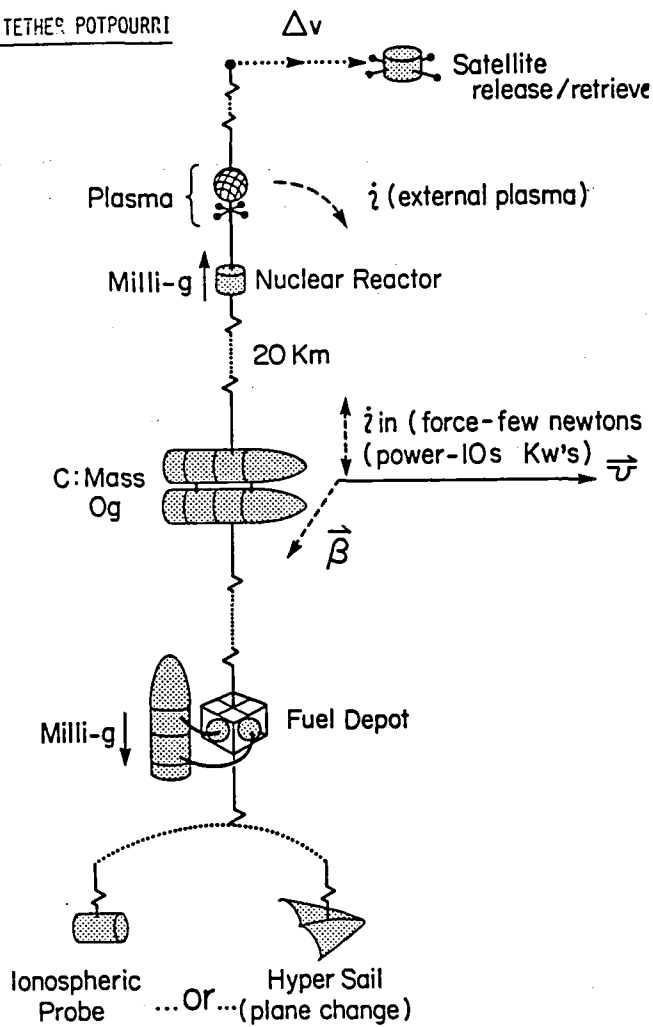

Transferring Pallet to Experimental Station

At the extreme, you can turn the boom into a raft using very massive collections of external tanks.



There is a possibility of using differential air drag across a structure. The low drag high ballistic coefficient element and the high drag low ballistic coefficient element gives you tension in the velocity vector direction, allowing you to start spreading out your array even more.



COLOMBO STATIONS

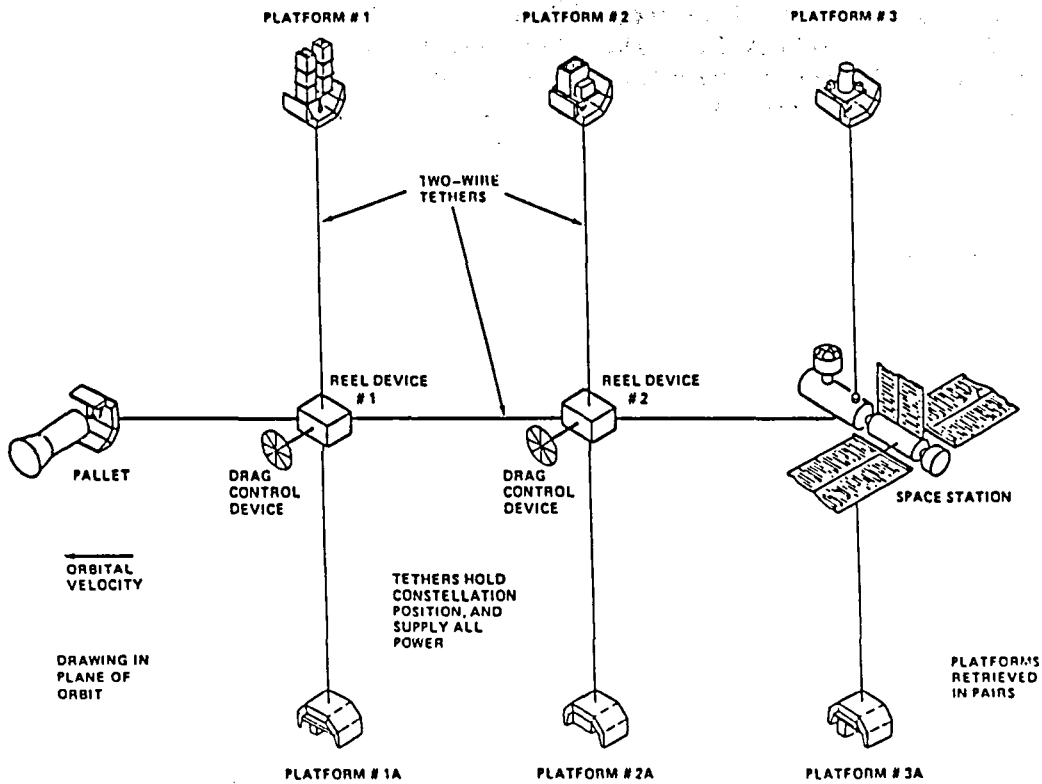
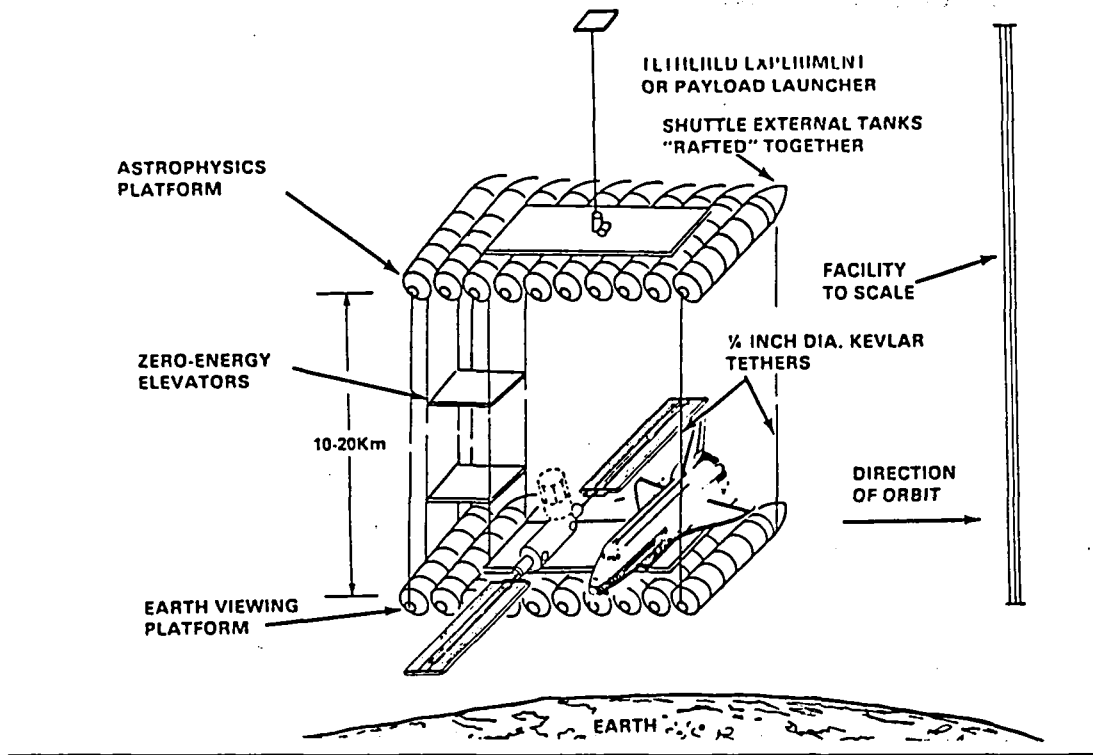

In this chart, types of tether configurations have been broken into two very broad areas, dynamic constellations and static constellations. The static constellations were broken down into drag stabilized units, pure gravity gradient stabilized and combining the two into a set using both drag and gravity gradient stabilization. There are other possibilities, dynamic constellations in which centrifugal force is used to provide your 2D structure, converging them to your gravity gradient forces to end point or perhaps like a wheel roll around in orbit.



This chart gives examples of connected constellations. There is the possibility that storage of very massive resources will be one very major use of these types of configurations; another might be the sub-orbital dumping of debris. With a manufacturing system at work in the near atmosphere portion of a 1-D configuration, debris could go into lower altitude orbit and be removed by the atmospheric drag much quicker. That may be a way of getting rid of an accumulation of debris. Another might be mobile shielding against energetic electrons if you had very large areas that you could place between you and the primary direction of the electron beams. This would remove from your immediate vicinity sources of x-ray emission. Extended systems might be used as microwave outriggers or, as clusters to transmit and receive on the same frequency through different antennas. Perhaps extensive ground planes to the local plasma might turn out to be important. Now that is something that might be tested out in orbits somewhat higher than low earth orbit before you went all the way to GEO to try it. A very important thing about all of this is the fact that it is not just the possibility of small gravity that controls the gravity over an interesting range of conditions that may turn out to be very important for applications of extended arrays. Again a foreword in a Physical Review article noted that you could arrange multi-pole mass distributions to actually produce small volumes in which G was 0 to very high orders. And you might use radial. One that comes to mind in geosynchronous is the possibility of radial probes through the plasma clouds extended out to geosynchronous orbit. This is a very interesting and dynamic area. Here would be a way to study the earth's magnetosphere along a radial vector over long periods of time in a way that couldn't be done otherwise.



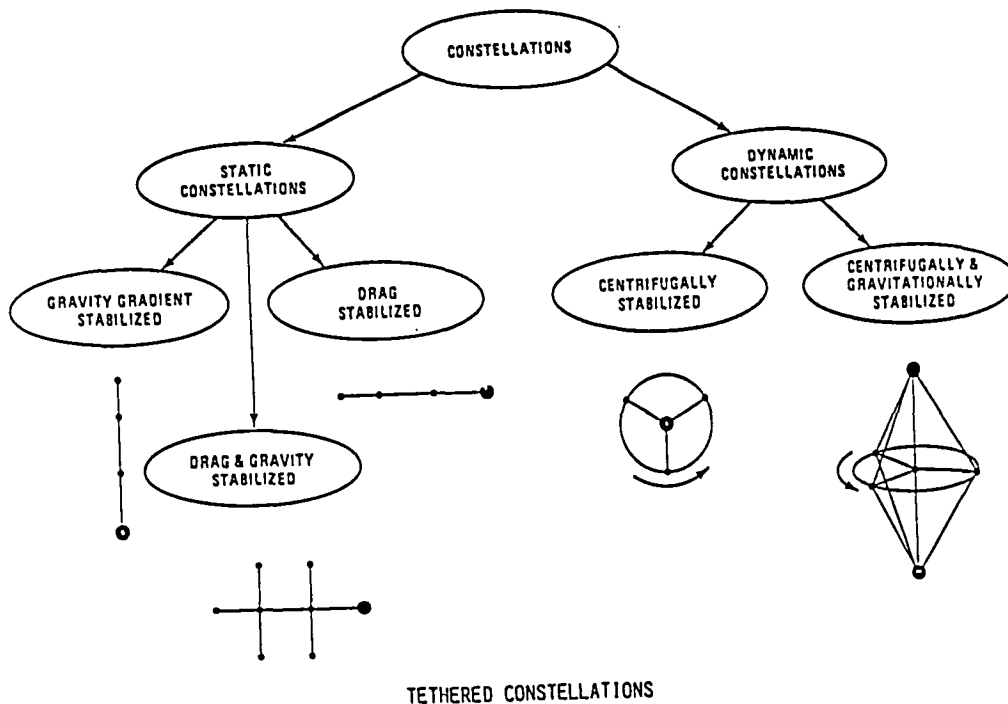

CONNECTED CONSTELLATIONS: EXAMPLES

APPLICATIONS

- STORAGE OF MASSIVE RESOURCES
- SUBORBITAL DUMPING OF DEBRIS
- DEPLOY SYSTEMS OUTSIDE OF LOCAL INFLUENCES (EX. SURFACE GLOWS, EFFLUENTS, WAKES, RFI, VIBRATIONS, ACCELERATIONS,...)
- MOLECULAR IMPACT SHIELDS (WAKE SHIELDS)
- PROBES AND TEST BODIES DEPLOYED TO IONOSPHERE AND UPPER ATMOSPHERE (PLASMA, REENTRY, HYPERSONIC FLIGHT, GAS RECOVERY(?), SINGLE OR MULTIPLE TETHERED LINES, COMMUNICATIONS(H,V,ULF THROUGH IONOSPHERE)).
- MOBILE SHIELDING AGAINST ENERGETIC ELECTRONS (LOSS CONE AND DRIFT BIASED)?
- ADVERTIZING & PUBLIC ANNOUNCEMENTS
- MICROWAVE - OUTRIGGERS, CLUSTERS, TRANSMITT/RECEIVE SETS
- PARASOLS
- EXTENSIVE GRIDDED GROUND PLANES TO LOCAL PLASMA
- LOFT FOR SOLAR SAILS
- HEO PARKING OF HIGH LEVEL WASTES

- MOMENTUM(S) & ENERGY BANKING
- SOLAR SAIL OFF-SET FOR GEO SATELLITES

SCIENCE

- SEGMENTED TELESCOPES & INTERFEROMETERS
- CONTROLLED GRAVITY FACILITIES - DRAG OFF-SET
 - CENTRIFUGAL
 - VIBRATION ISOLATION
 - GRADIENT (+/-)
 - HIGHER ORDERS (R.FORWARD)
- U/VLF WAVE ACTIVATION & LOCAL PLASMA EXPERIMENTS
- RADIAL PROBE THROUGH PLASMA PAUSE(GEO)
- STERO-IMAGER TRIPLETS (EARTH, LOCALE)
- MAPPING GRAVITY FIELD (GRADIENT FORCE)
- MULTIPLE LABORATORIES FOR: BIOLOGY, APPLICATIONS, SECURITY, MULTINATIONAL, COMPANIES, NATIONAL LABS.....

We should give more thought to the sense of how far can we take the process of filling up a large volume of space in a useful way, 3-dimensional way. According to Freeman Dyson and just based on simple gravity gradient calculations, you should be able to use lightweight structures to fill up their large volumes in earth orbit. Aerodynamics is clearly going to be a very major concern in rendezvous and docking, how you shake structures apart, how normal operations shake stuff apart, how you interact with the magnetosphere. These should receive a lot of attention. Qualitative things that haven't been looked at very much but clearly are important are central services vs. distributed capabilities. What advantages do you get from isolation vs. safety backups being close to you. Can you have long term utility and flexibility? There will be a lot of concern given to local transportation and also to human access both through improved space suits and possibly through local control of remote devices such as teleoperators. One thing that has been pointed out is that there was a lot of analogous work in teleoperators going on in the field of undersea robots used for deep ocean or industrial work in the ocean. There is quite a bit of experience there applicable in this area. We can look at this stuff in a way that we can see a creation of growing local resources.



MAJOR QUALITATIVE & QUANTITATIVE CONCERNS

- WHAT ARE THE OPTIONS FOR FORMING CONSTELLATIONS?
 - TETHERS - VERTICAL & ALONG DRAG
 - E-M INTERACTIONS (ACCELERATION & DRAG FORCES, TORQUE)
 - MAGNETIC ALIGNMENTS
 - SPIN-ORBIT COUPLING
 - TRUSSES - STATIC, DYNAMIC
 - DRAG ELEMENTS
 - COMPACT VS/OR EXTENDED 1,2,3^D
- DYNAMIC INTERACTIONS
 - CONFIGURATION AS IS
 - DURING RENDEZVOUS & DOCKING
 - CONFIGURATION CHANGES (QUICK, GRADUAL)
 - DEPLOYMENT PHASES
 - MAGNETOSPHERIC & ATMOSPHERIC CHANGES
 - THRUSTER PLUME EFFECTS
 - COLLISIONS WITH TETHERS(WHIP?) OR CENTRAL BODIES
 - TETHERS SNAPPING, DEGRADING
- CENTRAL SERVICES vs DISTRIBUTED CAPABILITIES
- ISOLATION vs SAFETY BACKUPS, ACCESSIBILITY, EASE OF INTERCHANGE, MINIMAL INTEGRATION, REDUNDANCY
- LONG TERM UTILITY, FLEXIBILITY
- LOCAL TRANSPORTATION METHODS
- HUMAN ACCESS
 - SPACE SUITS
 - LOCAL CONTROL OF REMOTE DEVICES (TELEOPERATORS,...)
 - EARTH BASED CONTROLS OF SYSTEMS, EXPERIMENTS,...
- CREATION OF GROWING LOCAL RESOURCES & OPPORTUNITIES
 - ENERGY & MOMENTUM VIA SOLAR POWER & E-M INTERACTIONS
 - ACCUMULATION OF MATERIALS RESOURCES
 - ETC.

Tethers in a different way open up the utility of large masses in orbit. They can be assets. This happens in several different ways. It might allow the reoptimization of the STS itself toward greater total mass and volume per launch. That would open up new ways of optimizing or upgrading the shuttle, even how you think about costing it. It might clearly enhance orbital energy momentum banks. There might be many uses for higher ballistic coefficients in orbits such as getting up towards hundreds of tons/m². Providing significant material resources on orbit should be extremely useful in thinking about a long term space program. For example, passive accommodations to the space environment yield either adequate shielding or long term time constants. This directly encourages a larger set of operations off earth. This will bring closer the re-accessing of the moon for use of resources. In a very general way, this is a village farm analogy. I think tethers might provide a way to combine the village and the farm. The village in this case could be something like a space station which could provide high cost common facilities at a core. You can have long range and a big bit rate communication. Heavy computing might be there and could accommodate labor, sometimes called astronauts. On the other hand, small satellites spread to the tether distance and could be specialized, semi-independent facilities. You could concentrate on reducing their cost and maximizing their accessibility to many other groups outside of the standard aerospace community. These might be used by national labs and universities. Perhaps France could support activity in a given small facility via Ariane. These user facilities could be specialized in various ways. They are interesting because they might give economies of scale in the production of the facilities or certain large housekeeping components of the facility such as power or local communications. It would open up also the possibility of creating local economic loops in space economies not economic space access but actually starting to do things in space that helps other space needs. One thing that may turn out to be extremely important is that it could simplify NASA interfaces to the outside world. If basically what you need is a string to hold onto and then talk to, your high bit rate comlink back to earth on a local basis might expand in a piecewise way. Minimal units of investment could be rented, leased, or remade in space to provide opportunities for other people to do things.



QUALITATIVELY ATTRACTIVE ASPECTS

oLARGE MASSES IN ORBIT (SPACE) CAN BE ASSETS:

- ALLOW REOPTIMIZATION OF THE STS TOWARD GREATER TOTAL MASS AND VOLUME PER LAUNCH (ETS, EXTRA & DIFFERENT PAYLOAD MIXES, BOOST OPTIONS).
- ENHANCE ORBITAL ENERGY-MOMENTUM BANKS.
- HIGHER BALLISTIC COEFFICIENTS POSSIBLE (TONS TO 100s TONS/M²).
- SIGNIFICANT MATERIALS RESERVES ON-ORBIT.
- PASSIVE ACCOMMODATIONS TO SPACE ENVIRONMENT.
- SHIELDINGS.
- DIRECTLY ENCOURAGE ACCESSING LUNAR RESOURCES TO SUPPORT LARGE LEO & DEEP SPACE OPERATIONS.

oVILLAGE-FARM ANALOGY

- PROVIDE HIGH COST, COMMON FACILITIES AT CORE (LONG RANGE & HIGH BIT RATE COMM., HEAVY COMPUTING, ACCOMMODATE LABOR,)
- MANY SPECIALIZED, SEMI-INDEPENDENT FACILITIES (ETS, PALLETS, SPACELAB UNITS OR SPECIALIZED PAYLOADS FOR USE BY NATIONAL LABS, UNIVERSITIES, COMPANIES, FOREIGN COUNTRIES).
- USERS FACILITIES HAVE NECESSARY SPECIALIZED RESOURCES (POWER, LOCAL COMM. & COMPUTING, CONTROLS,...).
- HAVE MANY USER FACILITIES TO ENCOURAGE:
ECONOMIES OF SCALE IN PRODUCTION;
LOCAL (IN SPACE) PROVISION OF GOODS & SERVICES;
SIMPLE NASA INTERFACES;
EXPAND PIECEWISE WITH MINIMAL UNIT INVESTMENTS & MANY RENT, LEASE AND REMAKE IN SPACE OPPORTUNITIES.

TECHNOLOGY AND TEST

Paul Siemers
Langley Research Center

This talk addresses the definition of the tether related technology status and the program that should be initiated to develop technology required by the satellite system and technology applications.



In looking at the tethered satellite system itself, it is necessary to go back and look at the technology that was developed and implemented in the successful Gemini program. Two problems in the area of technology have been identified. One is the state of dynamic modeling. This includes: the modeling of the tether itself; the tethered satellite; the influence of the tether satellite system on the shuttle and the implications of various perturbations and anomalies; the significant parameters that must be addressed; the state of the dynamic modeling systems that are presently available; and what work needs to be done and in what time frame. The second problem involves the materials that are presently proposed for the tether itself. From the recent experience on STS5 with the Kevlar experiment, it is known that there is atomic oxygen attack on the Kevlar material. How significant is that attack in the design of the tether and what materials must be developed to accomplish tether applications? The question marks are on the chart for the other technology problems that have been finally identified in the short period of time we have been working this task. Another item requiring examination is what are the manufacturing capabilities that exist to build components of the tether satellite system. The Langley Research Center is developing a process called pultrusion which will allow the manufacturing of an infinite length tether of any shape that is desired.



TECHNOLOGY AND TEST

- TETHERED SATELLITE SYSTEM
 - TECHNOLOGY APPLICATIONS
 - TECHNOLOGY AND TEST SUPPORT
-

TECHNOLOGY AND TEST

- TETHERED SATELLITE SYSTEM TECHNOLOGY
 - TETHERS IN SPACE EXPERIENCE: GEMINI
 - TSS: STATE OF TECHNOLOGY
 - DYNAMIC MODELING
 - MATERIALS
 - ? ? ? ?
 - MANUFACTURING TECHNOLOGY

The basic pre-defined technology areas appear to have application to tethered systems. In addition, supporting technology development is required relative to the instrumentation required to support tether application. Finally, the panel's activities are open to inputs from all participants.



The agenda for the Technology and Test Panel over the next few days.



TECHNOLOGY AND TEST

- TETHERED SATELLITE APPLICATIONS
 - ELECTRODYNAMICS
 - ATMOSPHERICS
 - POLAR ORBIT REQUIREMENTS
 - WAKE EFFECTS
 - AEROTHERMODYNAMICS
 - FLIGHT SYSTEMS
 - ORBITAL SYSTEMS
 - LARGE APERTURE ANTENNA
 - MATERIALS - TPS
 - STRUCTURES - LARGE AREA
 - INSTRUMENTATION
 - PANEL INPUTS
-

TECHNOLOGY AND TEST

- INTRODUCTION P. M. Siemers, LaRC
 - TETHER EXPERIENCE - GEMINI D. Lang, Consultant, JSC
 - TETHERED SATELLITE SYSTEM TECHNOLOGY STATUS D. Crouch, MMC
 - TETHER MATERIALS D. Crouch, MMC
D. Tenney, LaRC
 - TETHER SATELLITE SYSTEM DYNAMIC MODELING J. Slowey, SAO
 - TETHER MANUFACTURING J. MacConochie, LaRC
- ***LUNCH***
- ELECTRODYNAMICS LeRC
 - ATMOSPHERICS N. Engler, U of D
 - AEROTHERMODYNAMIC K. Sutton, LaRC
Col. N. Lee, USAF
G. Carlomagno, U of Naples
 - INSTRUMENTATION G. Wood, LaRC
 - ANTENNA RANGE P. Siemers for
W. Grantham, LaRC
 - PROPOSALS ALL

WHERE ARE WE GOING IN TETHERS

**Professor Giuseppe Colombo
Harvard-Smithsonian Center for Astrophysics**

Let me express first of all my deepest feelings of gratitude to NASA and, especially to the many people of NASA, and especially to my old friends with whom I began my work and the many friends who have contributed so much to my research. Most of the ideas I have had have been the product of the interaction with a large number of friends who often were more clever than I. Therefore, I do not know if I deserve the award which tonight has been bestowed upon me, or if I should share it with at least some of the friends with whom I have been closely working in the last 25 years since I came to the United States.

When I was 35 years old and had become a Professor of Theoretical Mechanics, I felt a pressing need for expanding my activities to widen the horizon of research beyond the necessarily confining limits of the scientific environment of my own town and my country. In older days, the spirit of the universality of knowledge, from which the name "university" derives in a sense, I was following an old tradition that particularly flourished in Italy during the Renaissance time, a tradition of the itinerant scientist. I came first to the United States where the action in space research was taking place. The decision had a revolutionary effect on my life, and in a few years, brought me in contact with a large number of people from the east coast, to the south, to the mid-west, to California. In Europe, my travels extended to England, France, Germany involving European programs of ESA and NASA. These extensive travels cost me a lot in terms of physical stress. However, it also gave me the opportunity of opening my mind to worldwide vistas of space research. Besides, and more importantly, I learned the basic theory that first you have to be ready to donate if you want to acquire and to receive. And secondly, that you don't have to keep track of what you owe and what you get, for checking the balance. The results were positive, even if my family and I had to pay a high price. During all this time the interest for scientific work kept mounting and has been providing the force and the courage to keep going against the odds, especially in the past 6 months.

Let's now move to the technical part of my speech. Where are we going with tethers? This is the title of my speech and I have made a list of the topics which I should speak about. However, what has been said in the sessions today is in a large part what I want to say tonight: in particular what is the state of the art of the tether at present in space science and applications and in space operations.

Therefore, I think I will limit myself to speaking about the history of the tether, and specifically, of my life with the tether. I was working back in 1974 on problems related to pipeline laying in the North Sea. I got acquainted with a very harsh environment of the North Sea, and the difficulty of laying a pipe down at the bottom of the sea, and when I came here my friend Mario Grossi asked me if I wanted to work with him on the possibility of deploying an antenna for ELF and ULF from the Shuttle. I thought that I had enough experience in long flexible members, that I could help him. So, in fact, we came up with the idea of the Skyhook in this way and from the Skyhook naturally developed the electrodynamic tether, and all other applications. We began thereafter to try to sell this idea.

The first invitation for presenting the idea was from Marshall Space Flight Center through my friend Chuck Lundquist. We went there and we made a presentation of the Skyhook. I had a feeling that at the beginning, the people were very skeptical but after 2 hours they weren't anymore. Well, as you realize, it took us something like 10 years to bring us here. If I could compare my few other things that I did in my life, I should say that it took me 5 minutes on the telephone to convince Irwin Shapiro that the rotation of Mercury was $2/3$ its orbit period. It took me 5 minutes to convince Bruce Murray to change the orbit of MVM 73 for making possible five flybys instead of one. It took me half an hour to convince Dr. Pickering that the Solar Probe was a mission deserving a very high priority. It took me 1 year to convince ESA to fly its Giotto mission. It took me the past 9 years to convince NASA to fly a tether.

You may ask why, and if, I have an explanation. In fact I have an explanation. You see, there is a fundamental problem here. How do we arrive at the dynamics of celestial bodies? You may arrive from the ground, or from the sky. When you arrive from the ground, you arrive with an experience of aeronautical engineering, or general mechanical engineering. When from space, you arrive with the experience of dynamical celestial bodies, the experience of space physics. This way you build up two completely different engineering fields while you have to deal with only one dynamic environment and you have to deal with engineering specifically for space. What happened is that space research grew up from aeronautics and mechanical engineering, carrying with it the weight and the difficulty of ground and air operation and the complexity of an environment which is controlled by random processes most of the time. While, when you start from the dynamics of artificial bodies in the sky, you generally come from an environment where deterministic processes are fundamental, and the random processes are negligible.

There is a fundamental reason science started in the sky. Because the dynamics in the sky are much simpler than the dynamics on the ground. Keplerian Laws were found before people understood the mechanics on the ground. We tried to interest NASA in the tether, proposing with MIT a dumbbell experience to the Advanced Applications Flight Experiment Program 5 or 6 years ago. This experiment was supposed to be launched on a Scout. We were thinking of deploying two satellites with a tether 50 to 100 km long. Unfortunately, this project was not accepted, but had history gone a little differently, we would have acquired very important experience.

As I said, the space dynamical experience is an environment where we have to make a new experience, a new sense, a new feeling. Not only us, I think, but even the astronauts. We both have to learn a little more of what is going on in operations exclusively for space.

Certainly, it is very strange that after the Apollo project, when we had come to a point where we had become familiar with very advanced space operations, we have to start again. However, and this is one of the fundamental reasons, it seems to me that because of the question of money, the speed at which NASA is now working and advancing isn't anything like the speed of the Apollo project. When I started the idea of

the Skyhook, we wanted to show that something which was impossible on the ground was possible in the sky by showing that a spaceborne tether 100 km long is feasible. It is the first really large structure in space. Those were the times when we were working with very large structures in space for solar powered spacecraft. So when I started, I started only with thinking big, we came up with the idea of using the tether for complicated systems. In the environment that we were then working in, the future of space was not only big, but also relatively close in time. Now, after having heard Bob Freitag today, I have the feeling that this process will be much slower than we think. The tether will fly possibly by the end of the 80s, and then people will begin to learn slowly what is going on in space.

Besides, I think the universities have to begin to teach a little more celestial mechanics to the students. For example, I today heard Chris Rupp speaking about the effects of the higher harmonics on the tether, for instance. But did anybody study the effects of the higher harmonics on the space station? Just to give you an example, I have been studying with one of my friends, Jack Slowey, at SAO, the critical inclination orbit, 63 degrees, which by the way is very close to the orbit of the Russian spacecraft. We found that in space you can modify the orbit simply, by just using the higher harmonics of the earth's gravity field. Or, you may ask how many engineering students know Cassini's laws regarding the motion of the moon? If you have a large space station, you have to know how the gravity gradient affects the motion of the space station about its center of mass. I have a feeling we are missing a fundamental point here.

Space technology is not the continuation of aerodynamics. This is the fundamental point. We are carrying into space something, the Shuttle, which is not meant for operating in space. It's made for carrying payloads from ground through the atmosphere into space. When we begin to think of building up something to operate in space then we have to think in a completely different way. Bob, today you said we have an evolutionary space station. But you don't grow a chestnut if you plant a small cherry tree. If you don't decide that now, you won't start well and you'll have to start everything again as you did with the Shuttle after Apollo.

It seems to me that I must be specific about what I am thinking regarding such a wonderful object like the Shuttle. I have been thinking in terms of the flexibility of the Shuttle. Not the flexibility you have now, the flexibility you will succeed in having in 3 to 4 years, before the tether will fly. I'm very worried about this. The 10 hours of tether deployment required today will reduce drastically in 4 or 5 years when we have more experience in space. This is a very big limitation we are accepting, naturally for very good reasons, for safety, at present. But we still have a system which will have a capability of doing much more than we can do today. So when we're speaking of where are we going with the tethers, we have to consider the evolution of space technology. If we don't consider the evolution of space technology and consider just the state of the art now, we will severely limit our possibilities in the future.

Certainly we may envisage two possible evolutionary patterns for the future of space and here I come back again with the work we have done with Phil Culbertson. If in space we are going to manage only information, then frankly I don't see a place for the Shuttle, but if in space we will do something else, which is most probable, then I see space for the Shuttle, and I see space for the tether as a fundamental basic structural element of the future.

SESSION IV
PANEL SUMMARY PRESENTATIONS

**SUMMARY PRESENTATION
OF THE
SCIENCE APPLICATIONS PANEL**

**Robert Hudson
NASA Headquarters**

First of all let me say a few words about the disciplines represented and the fact there will be some that essentially are not represented on this list.

- Geodynamics
 - Magnetic Fields
 - Gravity Fields
 - Magnetic Anomalies
 - Gravity Anomalies
 - Crustal Movement

- Aeronomy
 - Neutral Density
 - Ionospheric Physics
 - Chemistry

- Electrodynamics

- Earth Observations
 - Cartography
 - Land Use Classification
 - Vegetative Indices and Classifications
 - Hydrology

We have people here from the geodynamatics area and we're interested in studying magnetic fields, i.e., the rate at which ortho-normal magnetic fields change in time. With gravity fields, we're interested in magnetic and gravity anomalies and also interested in crustal movement. With the crustal movement there is really a positioning function. That is, if we have two beacons, one on the Shuttle and one on the tether, then we have a mechanism by which we can fix points on the ground. This gives us a much more accurate method for determining crustal movement.

In the area of aeronomy, we're interested in mutual density and also in composition particularly above 120 km where the atmosphere changes from a perfectly mixed, homogeneous atmosphere to one where each molecule is subject to each what is basically considered separation. Therefore, we get different rates of fall off with altitude with these ionospheric physics. We call this aeronomy because we really cannot separate the two. They act on one another and, therefore, to understand one you must understand the other. To fully understand the chemistry of

the atmosphere above 120 km, the atmosphere changes from an O₂ and molecular nitrogen atmosphere to one that is dominated by atomic oxygen. It's the rate at which it occurs that is of interest from a chemistry point of view. It is true to say that below 200 km we have limited data at this present moment. You have already heard from the technology panel that at 100 km, we have even less data. In fact, we are going to perform new basic research on the Earth's atmosphere with the tether system.

In the area of Earth observations, one can improve the resolution that is achievable by going to the lower altitudes. One can also improve spatial resolution and the spectral resolution. These areas that we have identified where we can use the tether allow us to improve the present state of knowledge in the area of cartography and land use classification; for example, crop classification and hydrology. These are the areas that we chose and what we have done is to put these things into some order of priority as to where to go with the tether system. What we have done is to try to define what the future applications of the tether system are required for our discipline. The reason we have one list is because we found as we went through each discipline beginning to require the same sort of development for the tether. Therefore, we put them on one list to represent all of our scientific needs. We call it "science" because we are very sensitive these days to the word "applications." There is always this feeling, and you hear it within NASA, which is NASA should be fundamental science and astronomy and applications; and the idea is that if you're working on the atmosphere or the land, it's second rate science. Earth sciences are the sciences we've removed the word "applications." I don't care if it's in the land or the atmosphere, it's science.

We believe that one really has got to exploit the present system; it may sound a silly thing to say, but we think that it is important to note that there is a lot of science that can be done with the present system.

FUTURE SCIENCE TSS APPLICATIONS

- Exploit present system
- Repeat missions
- Multiple payloads
- Lower altitude limit
- TSS from platform
- Free flying tethered satellites
- Constellations
- Planetary missions.

There are quite a few cases that need repeat missions. What we mean by that is that there needs to be guaranteed that these will have repeat missions. For example, the magnetic field of the Earth does not change that rapidly, but it does change. We need to follow that as a function of time. We may need one mission a year. We need a repeat mission to do that. Both those first two really don't require any new applications as far as tether is concerned. What we're saying is that there is a plethora of stuff we can do given the present system.

The first thing we would like to see added is ability to put multiple payloads onto the tether because we can do interesting things. We can get altitude profile of species. That's important because now we can begin to separate our temporal effects from spatial effects. Let me give an example of this. Thunderstorms and other interactions that occur on the surface of the earth generate gravity waves. These gravity waves are manifested when you get up to 120 km by changing the density with time. If we have one detector at one place and we see a change in density, we're never quite certain whether that's due to the moving of the satellite through that medium and, therefore, there is a special change or whether we are seeing a time change. One thing we can do by having several satellites or several satellites on a string is we can look at that whole gravity wave as it progresses up through the medium. You can see now how each of these detectors on the different satellites varies with time. We can begin to separate our time variations from spatial variations. Multiple payloads can also be used to obtain gradients although the general feeling of the group was that it is, in

fact, better to devise a gravity, radiometer and fly that in one satellite than it is to have two systems far apart. There are limitations. The lower altitude limit will have to be lowered. No question about that; we want to do flights which can get us down below 130 km. Our second priority insofar as applications are concerned is to get to those lower altitudes. We did discuss two ways of doing this. One is to lower the whole spacecraft down to lower altitude. One other system that we also considered was lowering a smaller secondary satellite down from the main satellite on a secondary tether. I think we even called it a subtether. One of the limitations that we see with the lower altitude limit is that you're going to reach a point where the spacecraft is going to skip along the top of the atmosphere. It won't go down any further. There is a whole range of engineering and other studies that must be made in order to really make certain that we can reach the lower altitudes. From a scientific point of view, there is a great deal of interest in it; and from an engineering or technology point of view, there is great interest in getting to those lower altitudes.

Having discussed lower altitudes, we next consider the fact that what we really would like, of course, is to do these tether missions for long periods of time. So we began to look at the whole question of the tether satellite system from a platform as distinct from Shuttle. The same thing that we have said before would apply to that particular thing also. The same bondages would apply--multiple payloads on a string, once can obtain over years, several years. One can also use the tether in this case to get away from the contamination which surrounds the platform which is one of the reasons why NASA is looking at the idea of a central space station with satellite clusters around it. Another way of doing that is to lower the thing on a platform. We really need to have a detailed study of just what stability can be obtained on what satellite system as it is lowered down from the platform. It is the stability for many of the measurements which is the important thing, especially the remote sensing measurements.

One of the proposals that was submitted to us includes the idea that for many purposes you need more than one angle of viewing of the Earth. The advantage in multiple payloads is that you can get more than one angle of viewing. For example, the sides of the SAR get an image factor which is highly angular dependent, and by looking at it at more than one angle, one can get much more information out of those two photographs or two images than one can get out of any single one. The reason for that is that the difference in the look angle gives you different topographic information. By combining those two, you learn a lot about the overall topography that you're looking at. The next thing we considered were free flying tether satellites. The original idea was basically to have one satellite beneath the other so that we could look at (with about one scale height apart in the atmosphere) the differences between temporal and spatial effects. We looked at the whole question of constellations because we'd also like to look at the variability in the horizontal plane. Some of the things that we saw coming out of the constellation group, the idea of satellite vertically displaced vs. horizontally displaced would also be very useful for us to look at from the point of view of getting more information on the temporal and the spatial effects.

Finally, we don't see why the whole idea of the tether system could not be applied to planetary missions, in particular, to get payloads as close to the surface as possible and not only in some of the weak atmosphere planets such as the moon and some of the moons of Jupiter but also perhaps getting it even lower down above Mars and above some of the other planets as well. We think it could, indeed, once you look at the whole question as to whether the TSS principle could not be applied to planetary missions. We have one final thing about which we knew nothing and, therefore, we feel quite obligated to tell you all about it. We wanted to know whether the whole concept of constellations is not something the astronomy community might not be interested in. They are building quite a few of these large arrays on the ground to improve the resolution of their present instruments and it would seem to use that if one would apply the same principle to an array of detectors, telescopes--but in space that one might find an interest from that community as well.

**SUMMARY PRESENTATION
OF THE
ELECTRODYNAMICS INTERACTIONS PANEL**

**Noble Stone
Marshall Space Flight Center**

Table 1 gives a list of ideas for technological and scientific uses of electrodynamic tethers in space considered by the electrodynamic interactions panel.

TABLE 1
ADVANCED APPLICATIONS OF ELECTRODYNAMIC TETHERS IN SPACE

- I. TECHNOLOGY
 - 1. POWER GENERATION (HI-I, LO-V)*
 - 2. THRUST GENERATION
 - 3. ULF/ELF COMMUNICATION
 - 4. ENERGY STORAGE
 - 5. IN-PLANE SHEET PLASMA CONTACTOR
 - 6. THRUST GENERATOR FOR PLANETARY CAPTURE
 - 7. INTERPLANETARY PROPULSION (SOLAR WIND)

- II. SCIENCE
 - 1. GENERATION OF WAVES IN PLASMAS
 - 2. FIELD ALIGNED CURRENTS
 - 3. LARGE BODY SHEATH AND WAVES
 - 4. PROCESS SIMULATION (SOLAR SYSTEM AND ASTRO-PHYSICS PLASMA SIMULATOR)

* ~1 KV.

In terms of the power generator, what is really required to generate utility power for general use on a space station is not a hundred kilometer tether. You don't want high voltage-low amp power for space station utility power. You'd rather get the high power by having high current and low voltage. This simplifies the situation in several ways. It gets away from the high voltage tether insulation problems, the high voltage isolation of the spacecraft, and also simplifies the conversion of the power into a usable form. One idea that we examined makes use of the constellation concept with a number of tethers deployed in parallel to generate the higher current (see Fig. 1).

This has several advantages. First of all, it provides a number of contact points with the ionospheric plasma. One of the problems that looms the greatest in this application is the ability to make adequate contact with the plasma and extract or exchange charged particles with it. So the ability to multiply the contact points increases the area of contact. This is important. The tethers will be somewhat shorter,

generating lower voltages, 1 kV rather than 20-30 kV. The current would be higher, 50-100 amps. This brings us into a parameter range where power converters are readily available.

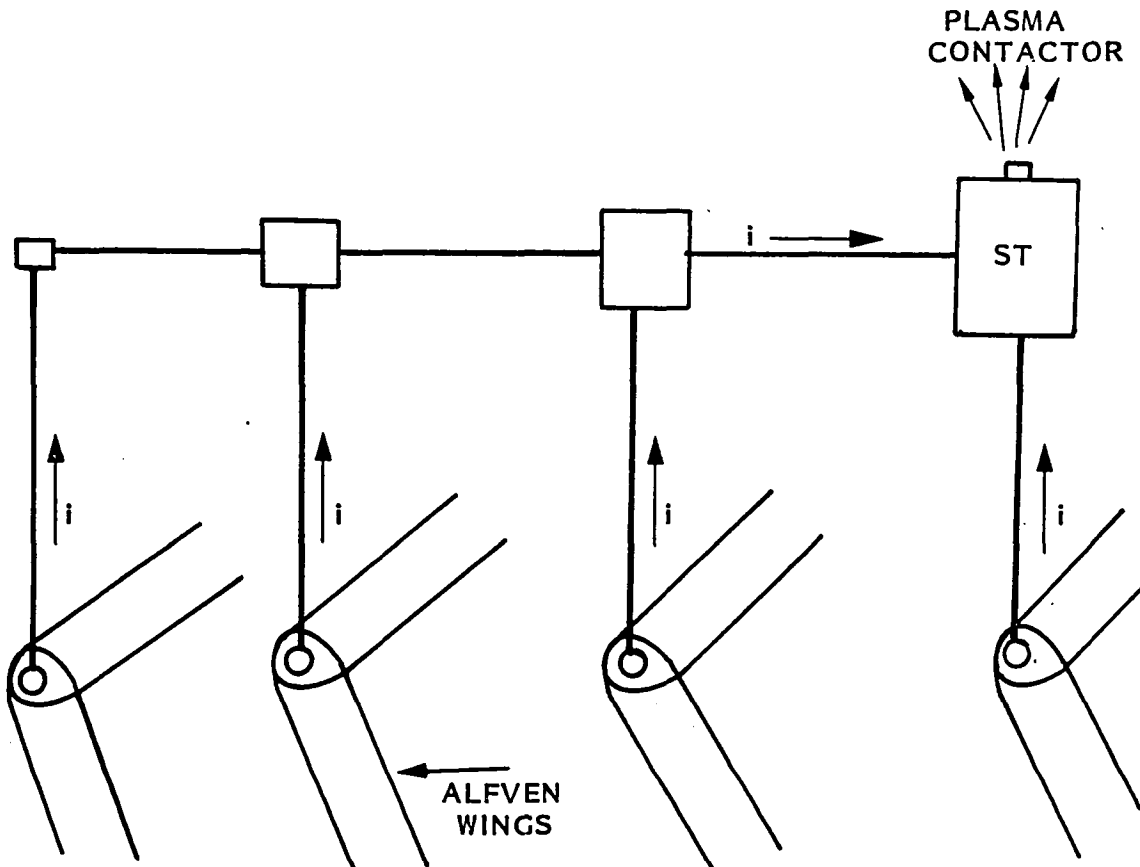

Figure 1. A Parallel Tether Current Generator

We were highly concerned about the mass of the tether and especially its mass once adequate insulation is applied to it for the very long power generation tether. A massive tether with massive insulation would be difficult to deploy. One way to solve this problem is not think of it in terms of deployment but, rather, in terms of erecting a semi-rigid system to remain there permanently. Oscillations would be taken out by varying the electrodynamic properties. If you think in terms of a semi-rigid tether concept, NASA has under development a program for a beam builder which takes a roll of flat material and rolls it out, molding it into a long beam. The system was designed to fabricate truss structures.

However, in this case, one can simply take a roll of material of the desired weight, roll it out, deforming it into a semi-rigid "beam" tether. The material could be pre-coated with as much insulation as required. It would be rigid enough to ease the problem of the initial erection and the tether dynamics and orbital dynamics would maintain it in position at greater distances. It wouldn't be rigid enough over a 10 km or a 20 km distance to keep its shape but then the normal tether orbital dynamics would maintain its shape.

In terms of thrust generation, the thrust vector from the $\vec{I} \times \vec{B}$ force is not always velocity aligned. In fact, one has to work at the situation in order to attain useful force to lower or raise the orbit. You don't just turn it on and leave it on because the angle between the velocity vector and the force varies over the orbit. Rather, one has to select portions of the orbit where the force is aligned in the required direction. Recognizing this, it's quite obvious that in addition to raising and lowering the orbit, one can also change the angle of inclination.

In the area of energy storage, the addition of a small increase in orbit height provides additional energy to be dumped back through a tether power generator at times when peak electrical power is needed. This technique can be used, for instance, with solar arrays because in low earth orbits solar arrays provide power only during the daytime. That being the case, a space station or platform would require a lot of batteries, which are very heavy, in order to store power for use during the nighttime. The energy storage technique, using the tether as a motor generator, could be used to make up this deficit at night. The orbit is simply raised slightly during the daytime, and the power dumped back down through the tether at night when no power is available from the solar arrays. This represents a different application of the tether thrust/power generator concept.

A new idea concerning contact with the plasma was presented today. If very large inflated balloons are deployed for plasma contact, the drag

becomes high enough that one has to become concerned about it. One way to get around this and still maintain the large collection area is to deploy an in-plane window shade type device. It could be a conducting mylar sheet deployed between two rigid structures. It can be in-plane since we're collecting electrons which are not aligned with the velocity vector. (It's the alignment with the magnetic fields that's important.) By being in-plane, the drag would be much lower while the collection area would be larger.

Another unique idea that was presented this morning was the use of a tether thrust generator on planetary missions for planetary capture (see Fig. 2).

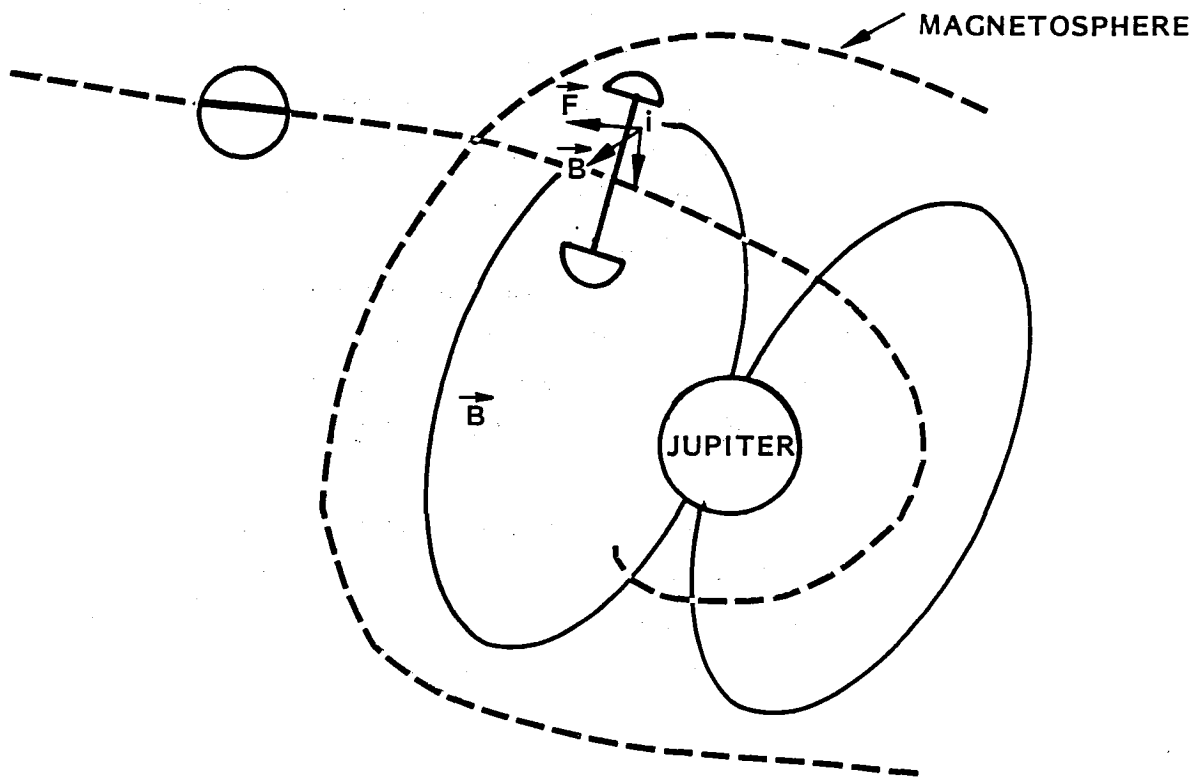

Figure 2. Electrodynamic Braking for Planetary Capture

Basically, the idea is that upon entering the magnetosphere of a planet with a strong magnetic field, such as Jupiter, the spacecraft splits into two halves and deploys an electrically conducting tether which conducts high current between the two pieces. The force generated decelerates the spacecraft allowing it to be captured in orbit about the planet. Of course, one has to look more closely at this idea to see if sufficient thrust can be generated to allow capture during one encounter. Otherwise, some chemical or other propulsion source would be required in addition to the electrodynamic braking. A second modification of the thrust generation idea is a very old one. It was originally thought of some years ago by Hannes Alfvén. It involves using the interplanetary magnetic field to generate thrust for interplanetary flights. Thrust can be fairly low but over a period of months a very high velocity can be attained because the sun continually emits a high velocity solar wind which carries solar magnetic field lines with it. The spinning motion of the sun produces a spiraling motion of the field lines (see Fig. 3) which travel away from the sun at something on the order of 300 km per sec. In this case, it is not the spacecraft velocity that's important but the solar wind speed. The main force generator is going to be the current crossed with the solar wind velocity which is quite high, and ultimately one can approach velocities on the order of the solar wind speed. It could be a very useful technique on planetary missions and might result in much shorter transfer times and higher payloads.

In terms of science, what is really surprising, as brought out in several of the presentations, is the very rich possibility for scientific investigation of this area in earth orbit; particularly for studying parametric relations of processes and phenomena inherent to solar system plasma physics. This is an important consideration for two reasons. During times of active planetary programs, such experiments can contribute very significantly to the planning of planetary missions. In the late 50s and early 60s, when we first began to launch satellites, we began to learn something about the earth's magnetosphere. Much later when we went to Jupiter, it was the understanding that we had gained about the earth's magnetosphere that enabled us to understand what we

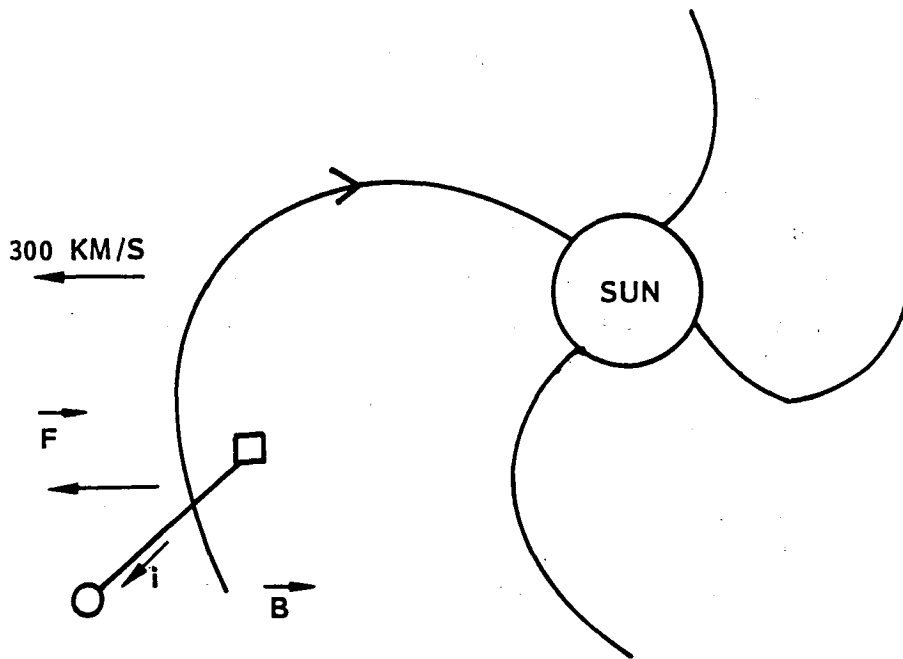

Figure 3. A Tether Thrust Generator for Interplanetary Missions

had observed at Jupiter and gain some insight into the nature of its magnetosphere. The same process can occur here. By understanding, in somewhat more detail, the processes involved, one could plan instruments, measurements and mission profiles that would greatly enhance the scientific output of planetary missions. In times like the present, when there are very few planetary missions, process simulation in earth orbit may, in fact, be one of the very few, if not only, means we have of learning much about the planetary processes. There is a possibility of studying a number of other effects such as field aligned currents, double layers, etc. that appear in our own earth system.

We spent most of the morning discussing some concerns that we have in regard to the application of the electrodynamic tether. Table 2 provides a listing of these areas of concern.

TABLE 2

AREAS OF CONCERN FOR TECHNOLOGICAL AND SCIENTIFIC
APPLICATIONS OF AN ELECTRODYNAMIC TETHER

- TETHER MATERIALS (STRENGTH, CONDUCTIVITY, INSULATION, ETC.)
- HIGH VOLTAGE TECHNOLOGY
- SPACECRAFT CHARGING
- VARIATIONS IN POWER WITH TETHER ANGLE AND MAGNETIC FIELD VARIATIONS
 - IMPEDENCE OF COLLECTION MECHANISM AND RETURN CIRCUIT REQUIRES EXPERIMENTAL AND THEORETICAL WORK
 - RADIATION LOSSES ALONG THE LINE—THEORETICAL STUDIES REQUIRED: SYSTEM RADIATION, STRUCTURE OF CURRENTS IN PLASMA
 - COLLECTION BODY PROPERTIES (E.G., EFFECT OF SIZE ON RADIATION AND ALTERNATE COLLECTORS)
 - COUPLING WITH IONOSPHERE; PLASMA DRAG AND WAKE—THEORETICAL STUDIES REQUIRED, LAB STUDIES IN EXISTING FACILITIES
 - EMIT PROPERTIES; IMPEDANCE, ETC.—PARTICULARLY WITH RESPECT TO HIGH CURRENT HANDLING CAPABILITY
 - $\vec{I} \times \vec{B}$ FORCE EFFECT ON TETHER ANGLE AND POSSIBLY ORBIT CHARACTERISTICS
 - DETECTABILITY OF RADIATION ON EARTH—THEORETICAL STUDIES REQUIRED, PROPAGATION MECHANISMS NOT WELL UNDERSTOOD. POSSIBLE TSS COMMUNICATIONS EXPERIMENT

Let me clarify the first tether materials concern. We're not talking about the tether used on the first two TSS missions. We recognize that there are some concerns there with the tether material but that's not what we're addressing. It is felt that the atomic oxygen problem and the insulation problems there are being dealt with adequately by current studies and are resolvable. What we're talking about here are the tether materials and insulations required for more advanced missions which have much more aggressive requirements. For example, in this workshop, we have considered tethering large, heavy structures. The current available tether materials are really not adequate. The strengths involved would require very large bulky tethers. If you're talking about tens of

kilovolts of potential, the insulations that we know of right now, and the techniques of applying those installations to conductors, are not sufficient. Then one has to worry about what happens with small meteorite pits which would penetrate the insulation, creating pin holes. It's known that such things as pin holes can cause a large scale breakdown in the vicinity of the conductor. So these are areas which need technology development.

Table 3 gives a list of recommendations. First of all, in attacking the problem of contact with the plasma, we felt it would be useful to have a proof of concept flight experiment in which one would investigate various devices that could be used to make this contact, whether it be a passive, inflated conducting balloon, a window shade device, a hollow cathode which forms a plasma bridge (which is not well understood at this point), or just an electron gun. All of these techniques need to be studied and compared, optimized and actually investigated as to how well they work in orbit. We need further development of the theory in several areas and, in particular, the three identified under the second bullet. Alfvén wings are supposed to form in the vicinity of the satellite and propagate outwards down field lines. This is of scientific interest, but it's also essential for technological utilization. The Alfvén wings are the primary ways that the charge gets spread over a large area allowing conductivity at high current levels. If the Alfvén wings don't form, then we may have a serious problem. The theory right now is not sufficient to guarantee that the Alfvén wings will always form. The fact is that the present theory was developed in the mid-60s and is not very definitive. We need some better understanding of the Alfvén wings, what conditions they form under, and what kind of power dissipation they might be able to handle. Radiation in the higher frequency modes will act to heat the plasma which represents a loss in efficiency for the system. If we radiate a lot of power at high frequencies, the system may operate at a much lower efficiency; that's our concern. ULF and ELF radiation and propagation through the ionosphere is not very well understood either. We can't tell you now if you radiate at certain power levels with a tether antenna in

orbit, whether you will be able to detect the signals on the ground; or what level signal will be transmitted to the ground; or what size antenna would be required. This is another area that needs to be better defined from a theoretical point of view.

TABLE 3
RECOMMENDATIONS OF THE ELECTRODYNAMIC INTERACTIONS PANEL

- PROOF-OF-CONCEPT FLIGHT EXPERIMENT TO INVESTIGATE PLASMA CONTACTING DEVICES
- FURTHER DEVELOPMENT OF THE THEORY FOR:
 - FORMATION AND CHARACTERISTICS OF ALFVEN WINGS
 - RADIATION OF HIGHER FREQUENCY MODES
 - ULF/ELF RADIATION AND PROPAGATION THROUGH THE IONOSPHERE TO GROUND
- FREE-FLYER (WITH PLASMA AND WAVE DIAGNOSTICS) TO MEASURE WAVE EMISSIONS AND PLASMA PARAMETERS IN THE NEAR FIELD OF THE TETHER/SATELLITE
- GROUND BASED MEASUREMENTS OF ULF/ELF EMISSIONS
- LABORATORY INVESTIGATION OF:
 - PLASMA WAKES AND ELECTRODYNAMIC DRAG AND EFFECT OF POTENTIAL
 - OPTIMIZATION AND CURRENT CAPACITY OF CHARGE EMISSION AND PLASMA BRIDGE DEVICES

We identified the need for a free-flyer for a number of reasons. The main purpose would be to make plasma and the various wave mode measurements in the near field of the tether. To do so, the free-flyer should be instrumented adequately with plasma and wave diagnostics. This allows measurement of emissions near the tether and, with the use of ground-based measurements, and the received power levels on the ground. This, in turn, gets folded back into the theory and we should then begin to develop a very good understanding of radiation transmission through the lower ionosphere to ground. We need ground-based laboratory investigations in the areas of plasma wakes and electrodynamic drag. The effect of very high voltages in this area has not been looked at

nor has the optimization of various devices for making contact with the plasma. For example, the hollow cathode device has been used for a number of years, but it has been used as a cathode in ion thrusters. What we want to use it for is a different thing entirely. It may not be optimized at all for plasma contactor purposes. So we need to make sure that it's optimized, that it works efficiently, and we have designed into it the highest possible current capacity.

**SUMMARY PRESENTATION
OF THE
TRANSPORTATION PANEL**

**Maxwell Hunter
Lockheed**

We have not yet arrived at a totally well-ordered priority and sequence of all this but what I am going to do is go through ten different suggestions that we came up with and being inventors and followers of instructions, we have a cartoon figure for each suggestion--courtesy of some nifty drawing that was done in real time this morning. We have this sequence of events. The first one is just plain to enhance the Shuttle delivery of payloads to higher orbits (Figs. 1 and 2). We made this in sequence of running through the benefits--what our assessment of practicality, most of the time we have questions on things like cost benefits, and of course, operational requirements. Of course, here the case is you can expect to go to higher orbits than you can with simply the Shuttle itself. Obviously not higher than you can do with all kinds of fancy upper stages. This is simply the separation of the payload, a sort of our basic system where the two of these are now in a gravity stabilized orbit; and when you release the Shuttle will come down; the payload will go to a higher orbit, and this seems to be one of the straightforward things you can expect to do relatively early in the game.

- BENEFITS: CAN REACH ORBITS CURRENTLY UNREACHABLE
- EXTENDS ALTITUDE AND PAYLOAD DELIVERY CAPABILITY TO HIGHER POLAR ORBITS
- PRACTICALITY: HIGH
- COST BENEFIT: ?
- OPERATIONAL REQUIREMENTS

Figure 1. Shuttle Delivery of Payloads to Higher Orbits

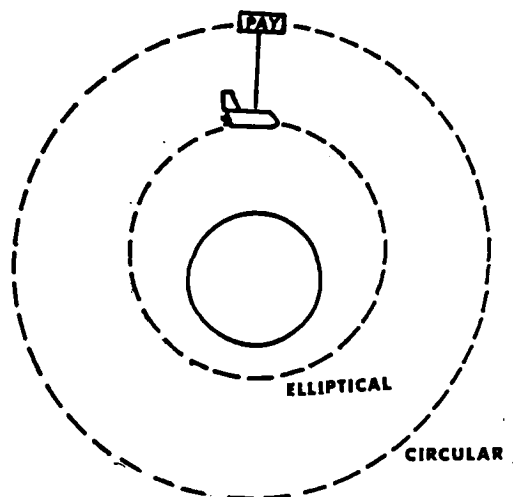

Figure 2. Placing Satellites in High LEO from Elliptic Shuttle Orbit

Now you can go to the question of having a Shuttle with an external tank and the question of the downward release of the external tank from the Shuttle (Figs. 3 and 4). In this case, you have the possibility of saving OMS propellant, increasing payloads and getting a control disposal of the extra tank. Most of these things are practical or we wouldn't be talking about them. A lot of these techniques are something that we're not use to. It's a sort of a different operational technique. Until people become familiar with them, practice with them, get a better feeling for them, and think about them, it's a little difficult to say about some of these things. Of course, you have had ways of attaching the ET to a tether from the orbiter and work out the various problems of impact prediction which should be relatively straightforward.

- BENEFITS: SAVES OMS PROPELLANT, INCREASES PAYLOAD, ALLOWS CONTROLLED DISPOSAL OF ET
- PRACTICALLY MEDIUM
- COST BENEFITS: ?
- OPERATIONAL REQUIREMENTS: ATTACHING ET TO TETHER FROM ORBITER, IMPACT ON ORBITER ALTITUDE CONTROL

Figure 3. Downward Release of ET from Shuttle Orbit

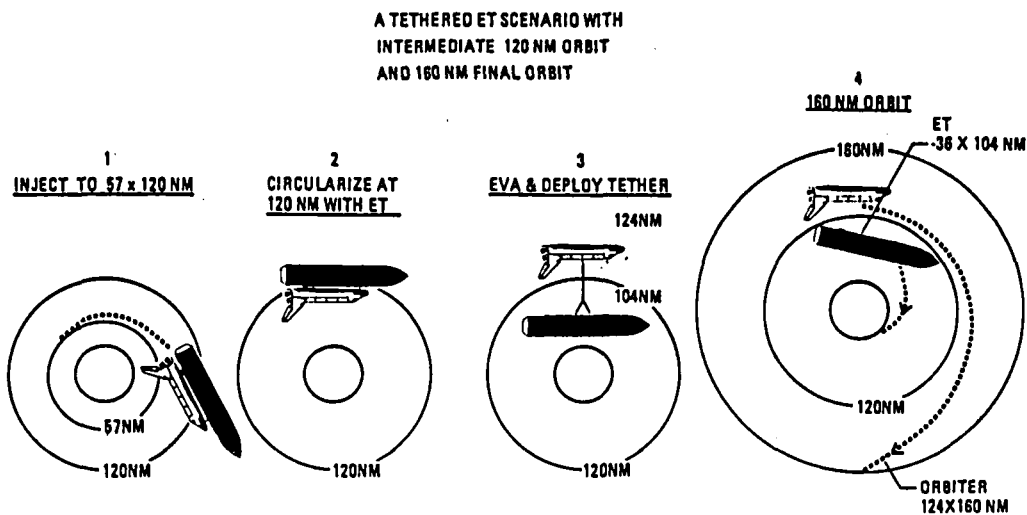

Figure 4. Typical Mission Scenario

The short of thing that we are saying here is shown in this sequence of events where essentially you take the ET which you've stabilized in orbit now by separating these two. We can use this to give more energy to the Shuttle--of course, you will pick up payload presumably because you can use the high energy propellants the whole way into orbit. This can be accomplished with relatively short tethers by which I means maybe 50 or 60 km. There is sort of a natural sequence of events whereas you try to get more performance out of tether systems, you tend to go to longer tethers which, of course, arrives at greater materials problems in developing the tethers. Some of the missions that you can come up with--this is an example of them--a relatively short orbit and relatively easy orbital structural problem. When you look at this performance, you quickly conclude that you like to have better and better tethers because that's where you get more and more performance if you decide, in fact, that these technique can be used. There is also a sort of growing involvement when you start talking about having both shuttles and a relatively large space station up there (see Figs. 5 and 6). You play the game a little bit in reverse and after you've got the shuttle to the station, you can transfer some of this momentum to the space station. So you do things like automatically deorbiting the shuttle while at the same time you get a higher energy orbit for the station. You have plenty of games using retransferring momentum back and forth between these systems just because of your skill in using tethers and your understanding of the orbital flight dynamics that you can use to your benefit. Therefore, you can, in fact, make these kinds of improvements--this one would appear to be fairly straightforward and again, of course, in the operational requirements, the case of learning to make tether reels and the things we are doing in our current experiments are one thing. We can now start to use these things in this way. There may be some interesting questions on how you're going to secure these tethers and how you're going to handle these operations with respect to these man devices that are up there.

- BENEFITS: STATION AND SHUTTLE PROPELLANT SAVINGS REDUCED HEAT LOAD ON ORBITER AS A RESULT OF A MORE GENTLE ENTRY
- PRACTICALITY: HIGH
- COST BENEFIT: UNKNOWN
- OPERATIONAL REQUIREMENTS: TETHER SECURED TO SPACE STATION

Figure 5. Space Station Altitude Reboost Using Shuttle Angular Momentum

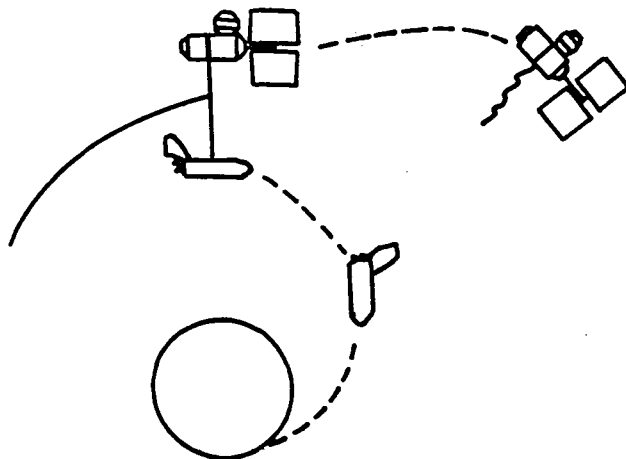

Figure 6. Reboosting Space Station by Lowering Shuttle When Ready for Reentry

There is no great significance as to where the tether is left go. The one on the figure was left to the artist's discretion. He obviously wanted to keep it on the space station. There is an interesting thing here. If you are deorbiting the shuttle, it's not clear that you can attach it that way because right now the shuttle operational requirements are such that you have to have the cargo bay closed before you initiate reentry. A little bit of thought, that's a logical thing. You can do this the way we normally think of tethers where they're on a reel down in the cargo bay. What you need is a quick disconnect after the cargo bay has been closed. So there may be a little question as the routine of tether design if you're going to use a system like this.

This is the case where depending upon how long you make the shuttle to be tethered and whether you use a swinging or gravity gradient stabilized tether, you start to get a strong interaction between the shuttle and the space station if you dock with a tether. And the longer

you make the tether, the more substantial the shuttle propellant savings. This can be used to transfer extra propellant to the space station if wish or carry more payload. What we are saying here is that the longer the tether, then the more you have enough courage to swing and rendezvous with it. The more you can start to, the shuttle will require less total Delta-V to get there, and therefore, you will be carrying more payload or if you go to a real extreme someday in the future, maybe you can even design a single stage vehicle to reach it. Another way of looking at it is the current shuttle. You are very likely to wind up with a lot of extra propellant when you dock and this can be transferred to the space station particularly if its usable in OTVs or upper stages of various sorts. This one I think is pretty good on practicality. It may take a little getting use to because now we are hanging together these larger devices. It would help if we had practiced this on some smaller things to start with.

We got into some interesting talks about this rendezvousing with this swinging tether, and there are several schools of rendezvous in the world. One says it takes a long time and you have to be very careful. Then there are retreads like me from the missile business that feel that rendezvous have sometimes been occurred in a matter of fractions of seconds and it ought to be implementable. In the missile rendezvous business, we never worried about accidentally colliding with the target. In this case, perhaps my loose intuition has got to be reined in a little bit. In general, if we have a swinging tether, you don't have to get this over with in fractions of a second, if you would like to do it in a minute or two. There is sort of an intermediate rendezvous case, which is where you can't go around a couple more orbits just because you didn't want to buy a decent IR. On the other hand, this absolutely hair trigger thing occurs in missile intercept where opposing velocity is very high. So we are going to work on that. That's something that seems to us a little bit of thinking starting along about now would be very helpful. Now there is another thing that comes out of this perpendicular deal. If you start making significant payload transfers by this process, you are going to start perturbing the orbit of the space station itself. That has interesting possibilities because in some

cases, you want to make up for orbit energy lost in the space station. That's liable to cause a huge urge for having electric or some form of high ISP rocket and it may make a requirement perturbation on the power required in the station. Furthermore, if this part of the station is part of a parade, it is latched up tight to other portions of the space station complex or even on tethers, if it is going to move around with respect to the others. It may not be any problem as far as the portion of the station which is the orbital refueling to which you are delivering the payloads. We do have a situation here where we start to make a major interaction with the shuttle transport vehicle on the part of the space station that docks is going to be moving around in respect to other portions of the space station complex. We need to give a little thought to that. This is a standard picture that goes with that (Figs. 7 and 8).

- BENEFITS:
 - SHUTTLE PROPELLANT SAVINGS
 - EXTENDED PAYLOAD
 - SAFETY DUE TO REMOTE DOCKING
 - EASIER PROPELLANT TRANSFER
- PRACTICALITY: MEDIUM
- OPERATIONAL REQUIREMENTS: PRECISE RENDEZVOUS MAY REQUIRE "SMART" HOOK

Figure 7. Shuttle Dock to Space Station Tether

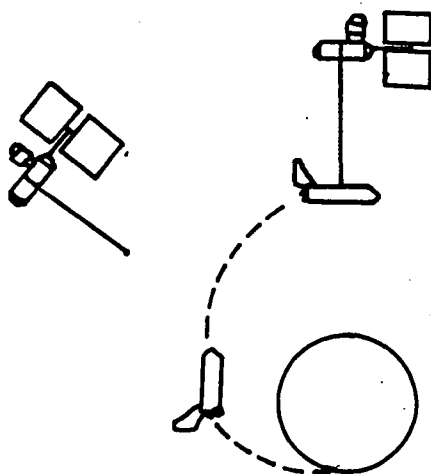

Figure 8. Docking Shuttle to Long Tether Lowered from Space Station--Enhances Payload and OMS to Station

Now so far we have talked about the cases where we're primarily dealing close to the space station and the shuttle orbit, but in fact, you can use these techniques for much improvement in payload deliver to very upper stage going onto higher energy orbits. That would appear to be relatively straightforward; and it's a matter of working out a bunch of conditions to see how you work this out, and how much you really gain. We tend to fill up the cargo bay pretty heavily with a lot of these things and with the chemical rockets so we may get into a question of the amount of space taken up in the cargo bay by the tethers and again this is very straightforward to visualize (Figs. 9 and 10).

- SHUTTLE TETHER FOR UPPER STAGE DEPLOYMENT TO HIGHER ENERGY ORBITS
- BENEFITS:
 - INCREASED PAYLOAD DELIVERY
 - LOWER PROPELLANT REQUIREMENTS
- ISSUE:
 - SHUTTLE ORBIT ENERGY AFTER PAYLOAD RELEASE TO BE ABOVE ENTRY CONDITIONS
 - SPACE IN CARGO BAY TO HOUSE TETHER

Figure 9. Shuttle Tether for Upper Stage Deployment to Higher Energy Orbits

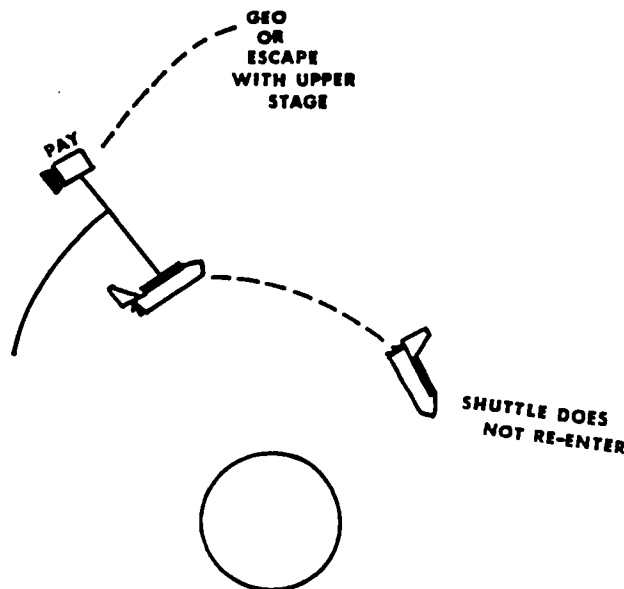

Figure 10. Using Shuttle-Based Tether to Assist Launch of Upper Stage for GEO or Interplanetary Orbits

This is simply the case that we tended to think of two different ways of doing these things, one where you are using only the shuttle for this work. The other is where you're basing it on the space stations (Figs. 11 and 12). You are doing much the same thing except in the case of the shuttle, you might be orbiting at the same time. In the case of the space station, you might use longer tethers, later heavier installations and, therefore, get more performance than you would just off the shuttle.

- 0 BENEFITS: LOWER PROPULSION REQUIREMENTS FOR SPACE STATION AND PAYLOAD (SYSTEM)
- 0 PRACTICALITY: MEDIUM
- 0 ISSUES:
 - SPACE STATION CHANGING ORBIT
 - INCREASED STATION POWER REQUIREMENTS

Figure 11. Space Station Based Tether to Deploy Payloads to Higher Orbits with Momentum Accumulator

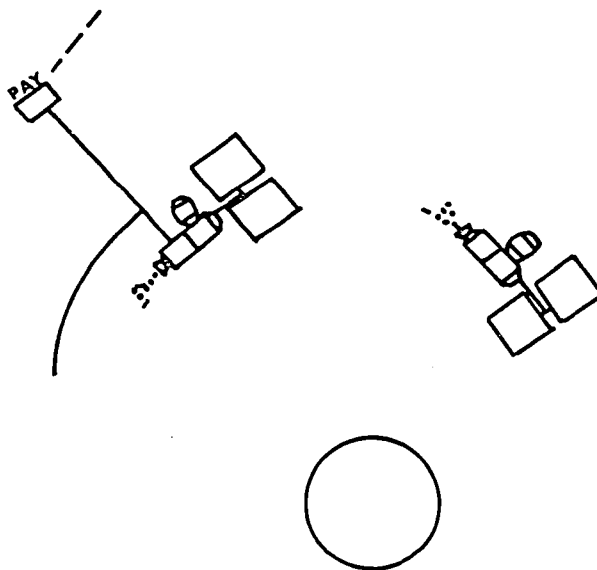

Figure 12. Using Station-Based Tether to Assist GEO or Deep Space Launch, Plus Electric Propulsion to Restore Orbit

In the game of changing angular momentums, you can, in fact, theoretically change the orbit eccentricity without an expulsion mask. You can do this by getting the vibration of the pair of tethered devices. It doesn't happen as fast as shown here. In fact by rotating

as you go, matching the period of rotation to the sort of unnatural period there, it turns out you can transfer to angular momentum of this librating satellite between that and the basic orbit in such a way that you will change the perigee and apogee without changing the rest of it (Figs. 13 and 14). There is a possibility here of circularizing orbits or making them more elliptic without, in fact, rejecting any mass. I'm not sure I understand exactly how long this kind of maneuver takes. It's a relatively new idea. It need substantially more thinking through before enough people are familiar with that one.

- BENEFITS: CHANGING ORBIT ECCENTRICITY WITHOUT EXPULSION OF MASS
- PRACTICALITY: UNKNOWN
- ISSUES: PRINCIPLE ESTABLISHED BUT APPLICATION REQUIRES FURTHER STUDY

Figure 13. Orbital Pumping

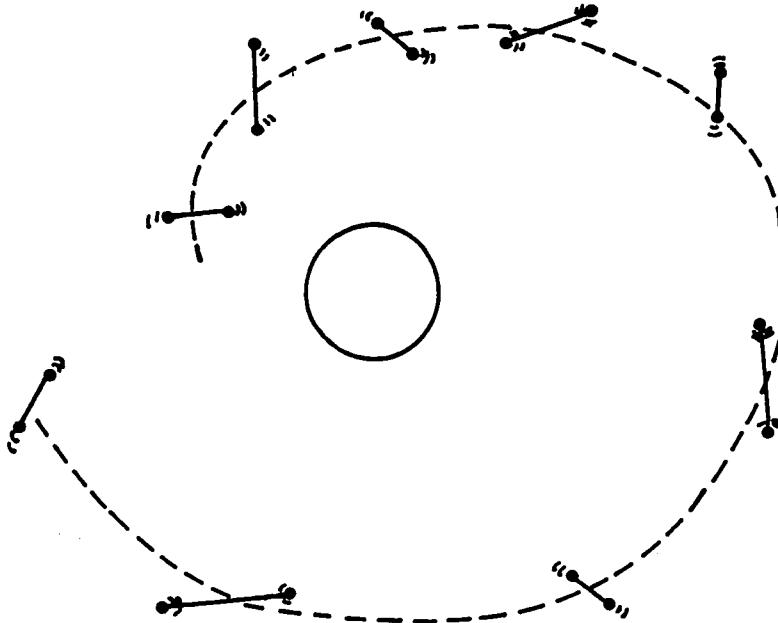

Figure 14. Modifying Orbital Energy and Eccentricity by Geometry Variations

Next is the case of putting air dynamic sails out in the atmosphere and using that for relatively large plane changes at low altitudes (Figs. 15 and 16). We think that is really pretty practical because it takes a lot of work. What you are trying to do is a very difficult performance product of making type plane changes at low altitudes. There is a lot of things that in this case have to be done. You've got tether sail materials. You need to make measurements to find out what the value of L/D is. You worry about tether drag. You have to understand how rapidly you can do this because it is a slow process compared to the plane changes that you could accomplish if you were willing to expend the rocket energy involved. In this case, there's about three different ways of thinking about it. You can do it in varying experiments. You can do it with the shuttle; it's unclear whether we want to use this as a shuttle maneuver technique because the sail requirement would be a large satellite. Later there's also the case where you operationally do this with the satellite that you are trying to change to get in a little different orbit. You don't push this large a mass around. Then there is the case of the experiments that you have to run and should run to learn about this very high speed regime. It is liable to require way too many shuttle flights and quite possibly is an excellent thing to be done in a space station because you have to do this more than once or twice before you are confident.

- BENEFITS: INCLINATION CHANGE WITH REDUCED PROPELLANT, ECCENTRICITY CHANGE. PROCESS POLAR ORBITS
- PRACTICALITY: HIGH
- ISSUES:
 - TETHER AND SAIL MATERIALS TO WITHSTAND HEATING LOADS
 - VALUE OF L/D
 - TETHER DRAG
 - SLOW MANEUVER IMPLEMENTATION

Figure 15. Aerodynamic Sails for Plane Change and Orbit Precision

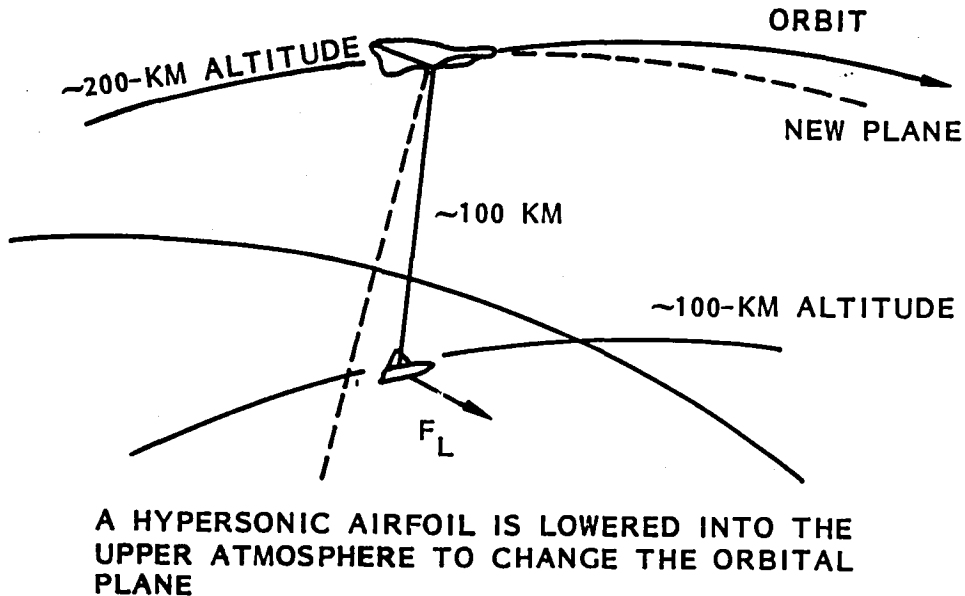

Figure 16. Satellite Sail

Even after you're way up there somewhere, you take just a simple case of the fact that you have a rocket that has just put a payload somewhere. Not you have a spent rocket stage. You don't know what to do with it. You can do some tether work and still get some momentum out of that and transport an orbital payload (Figs. 17 and 18). This is sort of a generalized technique.

- BENEFITS:
 - EXHANCED PAYLOAD DELIVERY
 - PROMPT, CONTROLLED REENTRY OF SPEND STAGES
- PRACTICALITY: MEDIUM
- ISSUES:
 - TETHER SYSTEM PLACEMENT
 - ENTRY OF TETHER

Figure 17. Tethers Which Use Angular Momentum of Discarded Stages to Boost Payloads

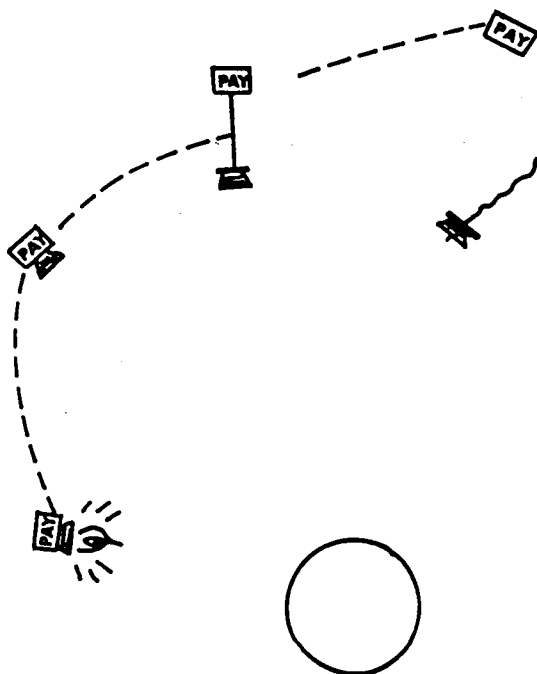

Figure 18. Using Tethers to Discard First Stages or Apogee Motors and Get Some Boosters

There was sort of a natural progression from early shorter shuttle to later longer shuttles if you want to carry that to extremes. Really there has been little thinking about what can be done in the various planetary programs or around the moon involving shuttles. It would appear there might be a number of things to get a closer observation of the bodies with tethers suspended below the satellite, play various energy management games. I don't think there has been much thinking here. In a lot of those cases as you get further from the earth, and in a lot of cases we are dealing with shorter lower gravity fields you tend to run into longer and longer tethers. On the other hand, you are dealing, in a lot of cases, this doesn't include Jupiter, with much lower gravity fields and, therefore, the practicality of building the tethers may, at least materials-wise, come about earlier than some of the relatively short but higher gravity fields tethers. So it may be that if you take this natural progression, the shorter, the longer, and then some decade you get around to very long ones, this might not apply in the planetary maneuver case. We think we ought to do some serious thinking about that in the long run and that is the end of those cases (Figs. 19 and 20).

- **BENEFITS:** CLOSE OBSERVATION OF BODIES, ENERGY MANAGERMENTS
- **PRACTICALITY:** ?
- **ISSUES:** COSTS, OPERATIONS, CONSTRUCTION

Figure 19. Planetary Applications of Tethers

TETHERS FOR
INTERPLANETARY
RESEARCH

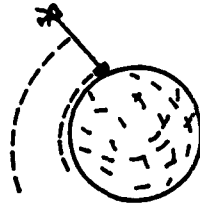

OR MOON BASED
TETHER ELEVATOR

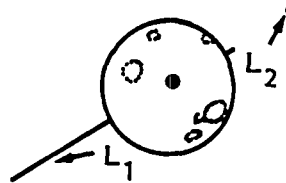
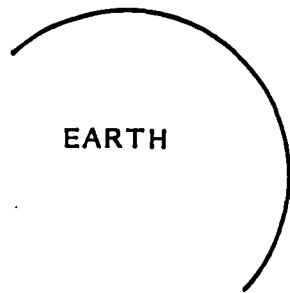

Figure 20. Planetary Applications

**SUMMARY PRESENTATION
OF THE
ARTIFICIAL GRAVITY PANEL**

**George Butler
McDonnell Douglas**

Pages 4-40 through 4-72 intentionally left blank.

- HIGHLY RECOMMEND AGGRESSIVE TETHER DESIGN DEVELOPMENT PROGRAM
- DEVELOPMENT OF TETHER DYNAMIC CODES - USER FRIENDLY
- MISSION/SYSTEM STUDIES RELATIVE TO TETHERED "WIND TUNNEL"
- DEFINITION/DEVELOPMENT STUDIES RELATIVE TO INSTRUMENTATION
- CONCEPT FEASIBILITY STUDIES

Figure 11. Recommendations

1. REPORT NO. NASA CP-2364		2. GOVERNMENT ACCESSION NO.		3. RECIPIENT'S CATALOG NO.	
4. TITLE AND SUBTITLE APPLICATIONS OF TETHERS IN SPACE - VOLUME 1				5. REPORT DATE March 1985	
				6. PERFORMING ORGANIZATION CODE	
7. AUTHOR(S) Alfred C. Cron, Compiler				8. PERFORMING ORGANIZATION REPORT #	
9. PERFORMING ORGANIZATION NAME AND ADDRESS George C. Marshall Space Flight Center Marshall Space Flight Center, Alabama 35812				10. WORK UNIT NO. M-475	
				11. CONTRACT OR GRANT NO. NAS8-35403	
				13. TYPE OF REPORT & PERIOD COVERED Conference Publication	
12. SPONSORING AGENCY NAME AND ADDRESS National Aeronautics and Space Administration Washington, DC 20546				14. SPONSORING AGENCY CODE	
15. SUPPLEMENTARY NOTES Alfred C. Cron: General Research Corporation, McLean, Virginia. Prepared by General Research Corporation under the direction of Dr. Georg Von Tiesenhausen, Program Development, Advanced Systems Office. Volume 2 - NASA CP-2365 Executive Summary - NASA CP-2366					
16. ABSTRACT The proceedings of the first workshop on "Applications of Tethers in Space" are summarized here. The workshop gathered personalities from industry, academic institutions, and government to discuss the relatively new area of applied technology of very long tethers in space to a broad spectrum of future space missions. This volume contains a description of the Tethered Satellite System, an ongoing project; and a section on tether fundamentals and applications and summary reports by the Panel Chairmen covering applications to science, transportation, constellations, artificial gravity, technology and test, and electrodynamic interactions. Specific recommendations to NASA were presented.					
17. KEY WORDS Tethers in Space Electrodynamic interactions Orbiter monitor transfer				18. DISTRIBUTION STATEMENT Unclassified - Unlimited Subject Category 37	
19. SECURITY CLASSIF. (of this report) Unclassified		20. SECURITY CLASSIF. (of this page) Unclassified		21. NO. OF PAGES 322	22. PRICE A14

National Aeronautics and
Space Administration

Washington, D.C.
20546

Official Business
Penalty for Private Use, \$300

SPECIAL FOURTH CLASS MAIL
BOOK

Postage and Fees Paid
National Aeronautics and
Space Administration
NASA-451



NASA

POSTMASTER: If Undeliverable (Section 158
Postal Manual) Do Not Return
