

PRELIMINARY RESULTS ON PASSIVE EDDY CURRENT DAMPER
TECHNOLOGY FOR SSME TURBOMACHINERY

Robert E. Cunningham
NASA Lewis Research Center
Cleveland, Ohio 44135

ABSTRACT

Some preliminary results have been obtained for the dynamic response of a rotor operating over a speed range of 800 to 10,000 rpm. Amplitude frequency plots show the lateral vibratory response of an unbalanced rotor with and without external damping. The mode of damping is by means of eddy currents generated with 4 "c" shaped permanent magnets installed at the lower bearing of a vertically oriented rotor. The lower ball bearing and its damper assembly are totally immersed in liquid nitrogen at a temperature of -197°C (-320°F). These preliminary results for a referenced or base line passive eddy current damper assembly show that the amplitude of synchronous vibration is reduced at the resonant frequency. Measured damping coefficients were calculated to $\mathcal{P} = .086$; this compares with a theoretically calculated value of $\mathcal{P} = .079$.

INTRODUCTION

- o Improved performance and durability of SSME turbopumps will depend, to a large degree, on an effective and predictable mechanism for dissipating vibrational energy in the rotors.
- o Properly designed dampers located at or near bearing supports can be effective in controlling vibrations produced by rotor unbalance, commonly known as synchronous whirl.
- o Dampers can also be effective in controlling non-synchronous whirl, the type often produced by shaft internal hysteresis, hydrodynamic seals, interference fits, tie bolts, etc.
- o Dampers can reduce the dependence on ultra precision balancing or the need for frequent rebalancing.
- o Dampers along with properly designed flexible bearing supports can reduce magnitude of transmitted forces thru the ball bearings to the casing, and thus extend ball bearing life.
- o A unique method of damping is by means of eddy current generation in a conductor caused to vibrate in a magnetic flux field.
- o The low temperatures encountered in the turbopumps actually increase the available energy dissipation and thereby make this mechanism an attractive candidate for SSME turbomachinery.

- o An objective of this work is to verify by experimentation the derived relationship that define the eddy current damping coefficient.
- o A rotating rest apparatus was designed and fabricated in order to properly evaluate candidate damper designs over a speed range of 800 to 10,000 rpm while operating in liquid nitrogen at -195°C .
- o Measured rotor response to unbalance forces with and without applied damping are compared to theoretical results from a computer code.

SUMMARY AND CONCLUSIONS

- o Demonstrated the successful attenuation of synchronous vibration at the first system resonance using passive eddy current damping in liquid nitrogen.
- o Obtained reasonable agreement between theoretical and measured response of an unbalanced rotor for both the undamped and damped cases. A measured damping coefficient of $\mathcal{D} = .086$ was obtained while the predicted damping coefficient was calculated to be $\mathcal{D} = .079$.

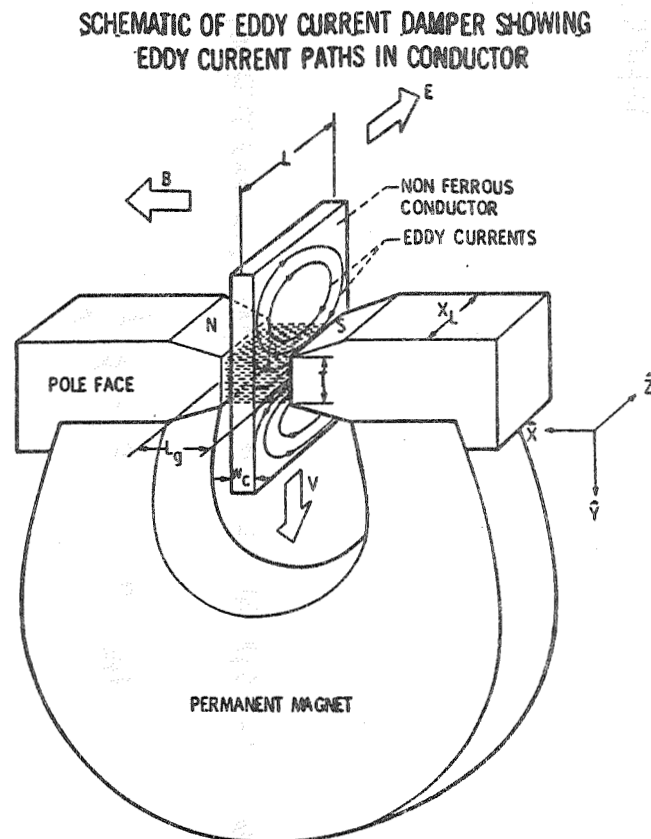

- STATING FARADAY'S AND LENZ'S LAWS IN EQUATION FORM
IT CAN BE SHOWN THAT:

$$(eq. 1) \quad F_M = \frac{B^2 \ell^2}{R} V \quad (\text{NEWTONS})$$

WHERE: B, FLUX DENSITY, $\frac{\text{WEBERS}}{\text{M}^2}$
 ℓ , CONDUCTOR LENGTH, M
R, RESISTANCE, ohms
V, VELOCITY, M/sec

- OBTAINING F_M IN TERMS OF MATERIAL CONDUCTIVITY WHERE:

$$(eq. 2) \quad R = \rho \frac{\ell}{A} \quad \text{WHERE } \rho, \text{ ohms-meters}$$

AND

$$(eq. 3) \quad F_M = \left(\frac{B^2 \ell A}{\rho} \right) V \quad (\text{NEWTONS})$$

- THE CONSTANT OF PROPORTIONALITY IS KNOWN AS THE DAMPING COEFFICIENT, C_D THEREFORE:

$$(eq. 4) \quad F_d = C_D V \quad (\text{NEWTONS})$$

- EQUATING $F_M \dot{\epsilon} = F_d$ AND SOLVING FOR C_D WE HAVE

$$(eq. 5) \quad C_D = \frac{B_g^2 \ell A}{\rho} \quad \left(\frac{\text{NEWTONS-sec}}{\text{M}} \right)$$

- THE DAMPING FORCE IS VELOCITY DEPENDENT AS IS VISCOUS OIL SQUEEZE FILM DAMPING. MOST IMPORTANTLY HOWEVER THE DAMPING COEFFICIENT C_D VARIES AS THE SQUARE OF THE MAGNETIC FLUX DENSITY, B_g AND INVERSELY AS THE CONDUCTOR MATERIAL RESISTIVITY ρ

ELECTRICAL RESISTIVITY OF COPPER AS A FUNCTION OF TEMPERATURE

REF: NBS CRYOGENIC DATA MEMORANDUM NO. M-11

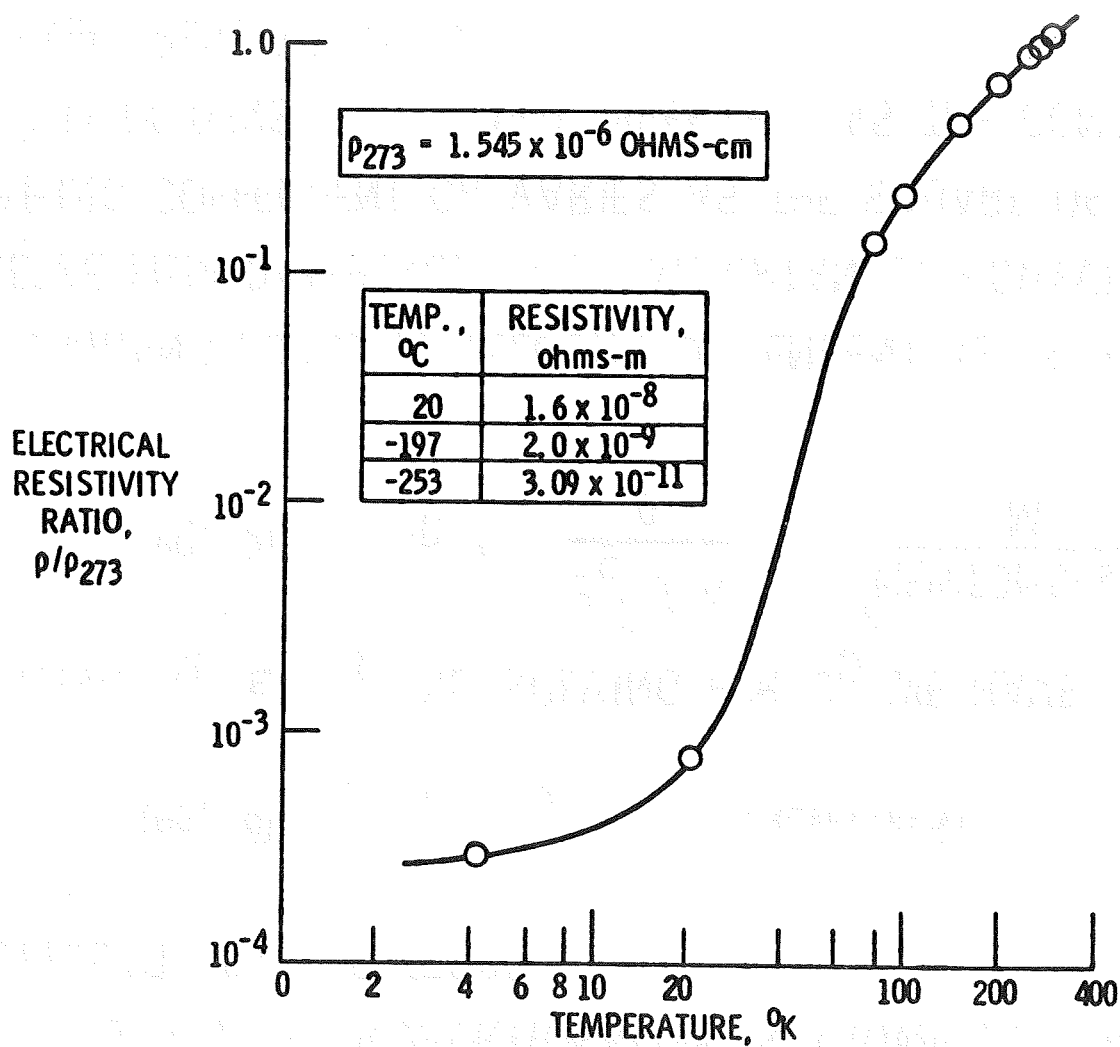

370

CS-84-0496

REVERSIBLE TEMPERATURE CHANGES IN REMNANCE FLUX AND COERCIVITY

REF: ARNOLD ENG'R

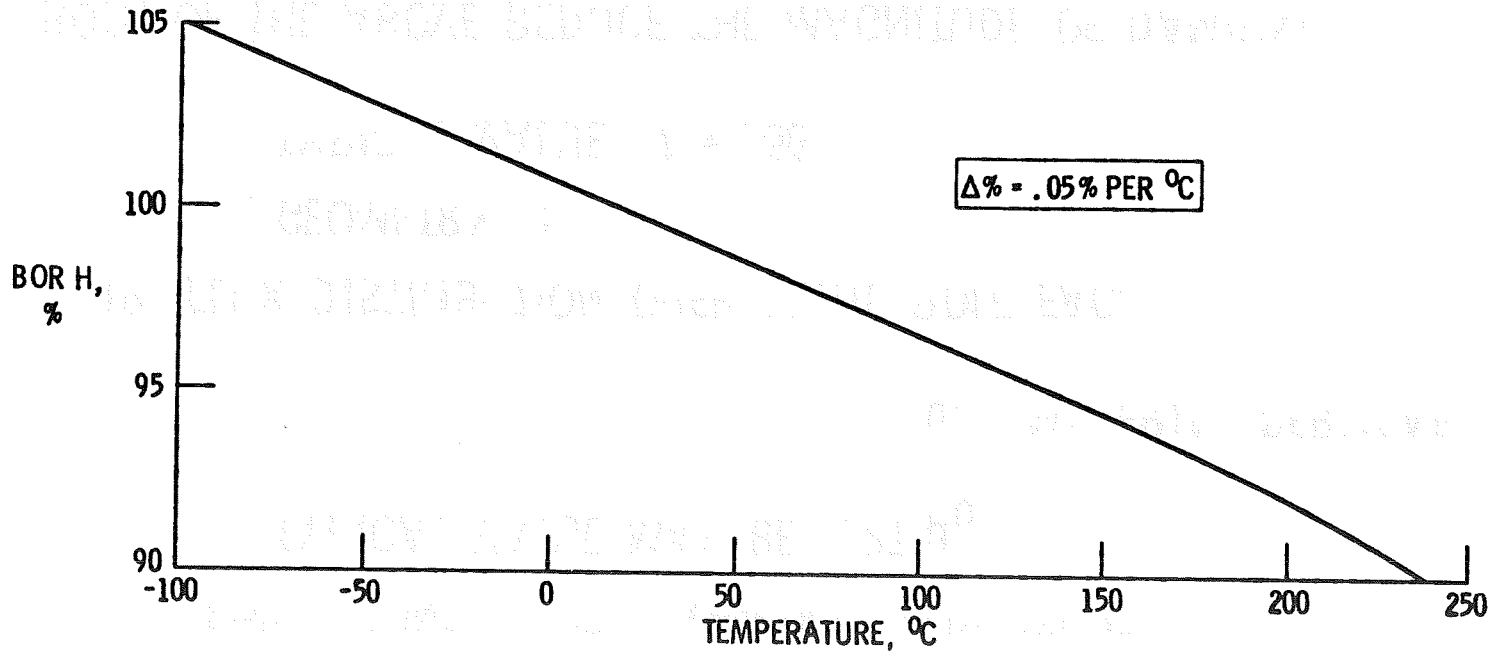

371

- THE EQUATION FOR DAMPING COEFFICIENT C_D MUST BE MODIFIED TO ACCOUNT FOR:

(A) FINITE CONDUCTOR GEOMETRY, INDUCTIVITY, L_i
 TYPICAL VALUE MAY BE, $.27 \mu_0$

μ_0 , MATERIAL PERMEABILITY

(B) FLUX DISTRIBUTION OVER FINITE POLE FACE
 GEOMETRY, f
 TYPICAL VALUE, $f = .66$

- BOTH OF THE ABOVE REDUCE THE MAGNITUDE OF DAMPING COEFFICIENT THEORETICALLY AVAILABLE

$$C_D' = \frac{(f B_g)^2 \ell A L_i}{\rho \mu_0} \left(\frac{\text{N-sec}}{\text{M}} \right)$$

THE FLUX DENSITY ACROSS AN AIR GAP, REF. FIG. 1,
 IS DETERMINED BY THE MAGNET MATERIAL AND ITS
 HYSTERESIS CURVE AND THE MAGNET GEOMETRY.
 THE FOLLOWING RELATIONSHIP IS GIVEN IN MAGNET
 DESIGN MANUALS.

$$B_g = \left(\frac{A_m}{A_g} \right) \frac{B_R}{\sigma}$$

WHERE: A_m , CROSS SECTIONAL AREA
 NORMAL TO MAGNETIC AXIS

A_g , CROSS SECTIONAL AREA OF
 POLE FACES

B_R , REMNANCE FLUX

σ FLUX LEAKAGE

$\left(\frac{A_m}{A_g} \right)$, FOCUSING EFFECT

σ , FLUX LEAKAGE IS A FUNCTION OF GEOMETRY.
 TYPICAL VALUES FOR "C" SHAPED MAGNET
 2.5 TO 4

PERMANENT MAGNET DESIGNS FOR EXPERIMENTAL EVALUATION IN LIQUID N₂ AND LIQUID H₂

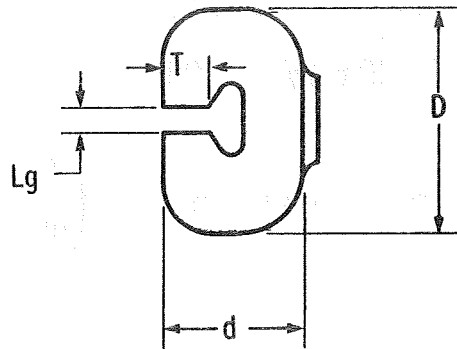

DESIGN A

"c" MAGNET MATERIAL, ALNICO V

DIMENSIONS

D = 2.4 in
 d = 1.5 in
 T = .5 in
 Lg = .25 in
 W = 1.2 in

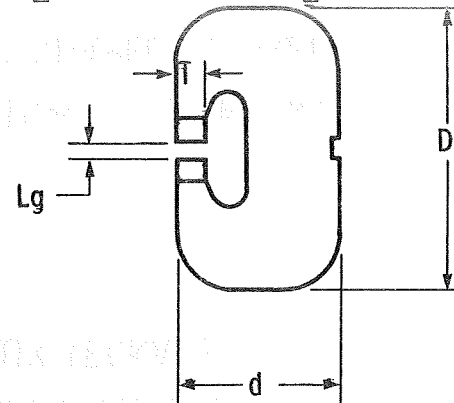

DESIGN B*

"c" MAGNET MATERIAL, ALNICO V
 POLE FACES, SAMARIUM COBALT

DIMENSIONS

D = 3.0 in
 d = 1.75 in
 T = .313 in
 Lg = .156 in
 W = 1.2 in

THEORETICAL DAMPING COEFFICIENTS

- ROOM TEMP. (20⁰ C)
 $C_D = .122$ lb-sec/in
- LIQUID N₂ (-197⁰ C)
 $C_D = 1.02$ lb-sec/in
- LIQUID H₂ (-253⁰ C)
 $C_D = 66.2$ lb-sec/in

- ROOM TEMP (20⁰ C)
 $C_D = 1.31$ lb-sec/in
- LIQUID N₂ (-197⁰ C)
 $C_D = 10.95$ lb-sec/in
- LIQUID H₂ (-253⁰ C)
 $C_D = 707$ lb-sec/in

* OPTIMIZED GEOMETRY, COMPUTER PROGRAM

EDDY CURRENT DAMPER

TEST APPARATUS - LN2

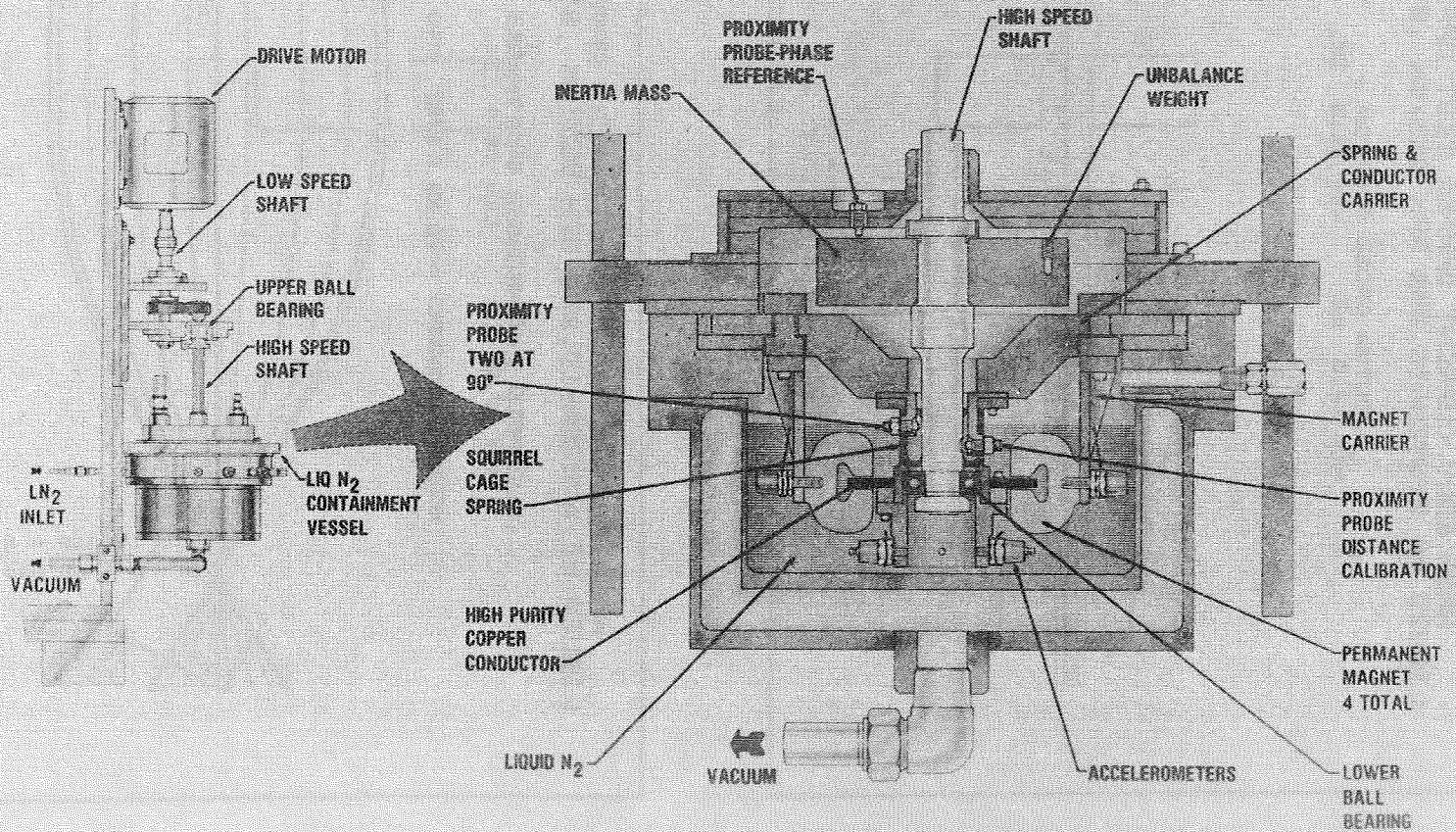

NASA EDDY CURRENT DAMPER TEST APPARATUS
 LIQUID N2 SYSTEM-15,000 RPM DESIGN ,STIFF SHAFT

- ROTOR CROSS SECTION -
 Mt= 17.5 LB Lt= 19.5 IN.

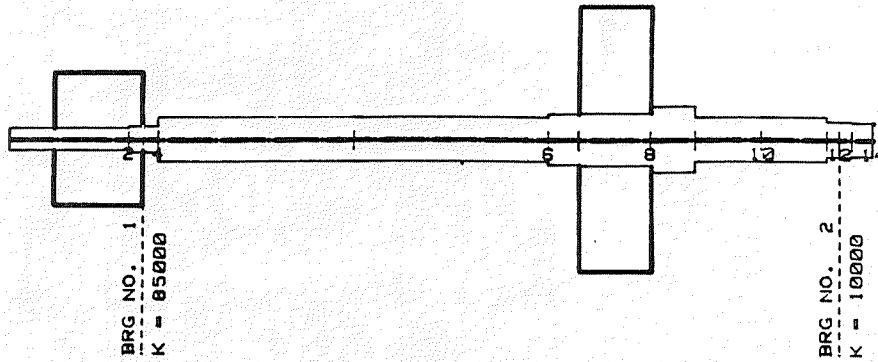

NO. OF STATIONS = 14
 NO. OF BEARINGS (&SEALS) = 2

NASA EDDY CURRENT DAMPER TEST APPARATUS
 LIQUID N2 SYSTEM-15,000 RPM DESIGN ,STIFF SHAFT

UNDAMPED SYNCHRONOUS SHAFTMODES
 Mt= 17.5 LB Lt= 19.5 IN.

MODE 1 FREQUENCY = 98 HZ (5920 RPM)

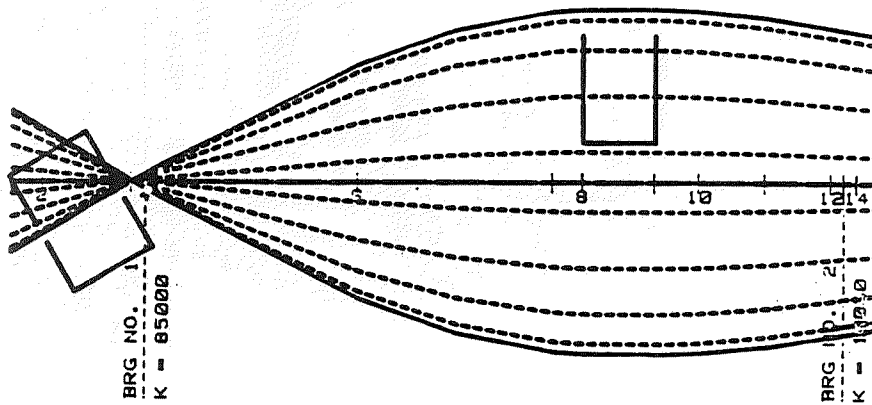

NO. OF STATIONS = 15
 NO. OF BEARINGS (&SEALS) = 2

THEORETICAL RESPONSE OF UNDAMPED VERSUS DAMPED ROTOR

UNBALANCE, 0.149 oz-in. ; THEORETICAL DAMPING COEFFICIENT ζ , 0.084

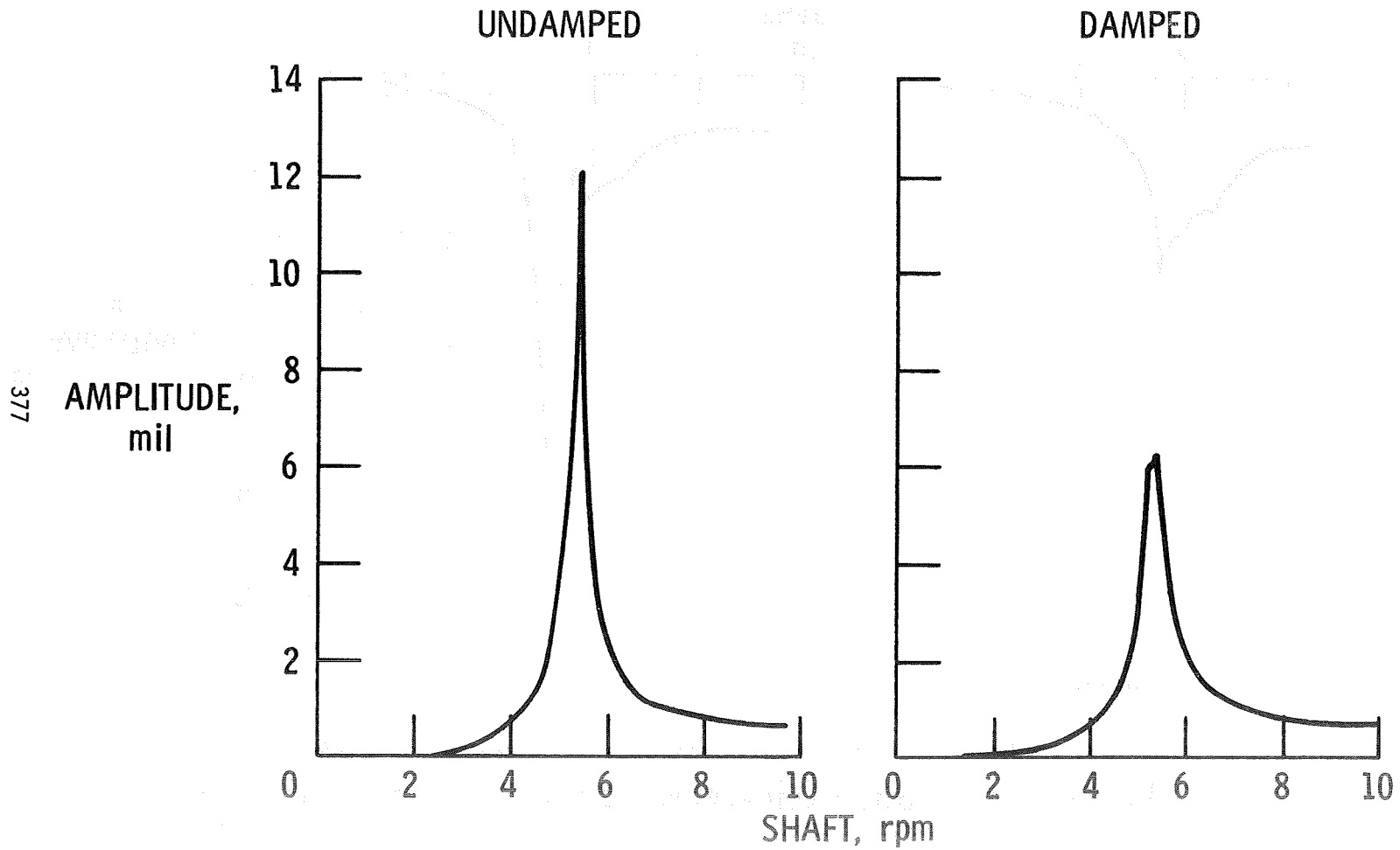

V-2144

MEASURED RESPONSE OF UNDAMPED VERSUS DAMPED ROTOR

UNBALANCE, 0.149 oz-in. ; MEASURED DAMPING COEFFICIENT ζ , 0.079

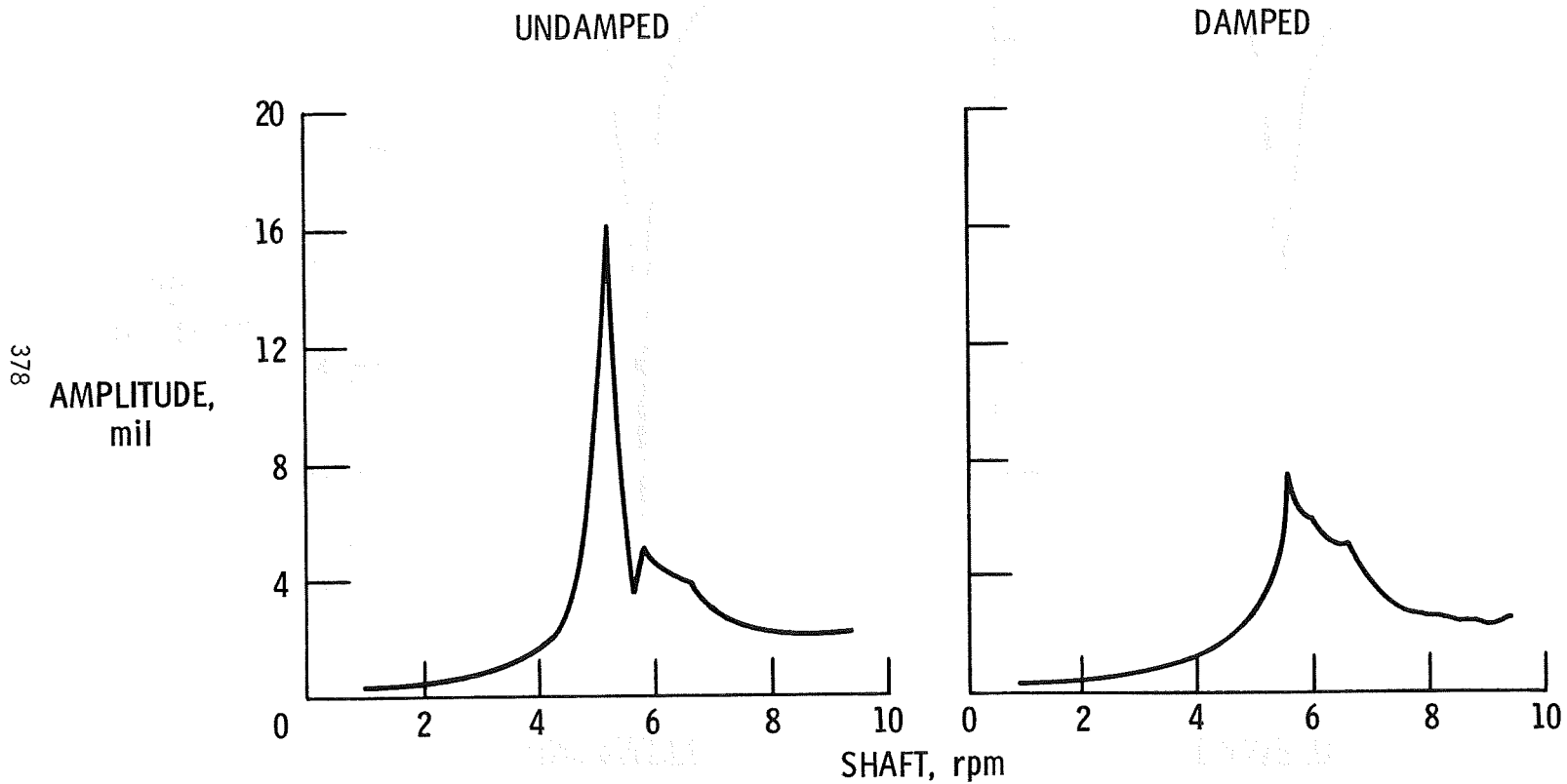

V-2143

SUMMARY OF THEORETICAL VS MEASURED RESPONSE FOR LN₂ TEST ROTOR

ROTOR UNBALANCE, .149 OUNCE - INCHES

SPRING CONSTANT, $K_s = 11,100$ lb/in

THEORETICAL RESPONSE

MEASURED RESPONSE

379

	<u>UNDAMPED</u>	<u>DAMPED</u>	<u>UNDAMPED</u>	<u>DAMPED</u>
RESONANT FREQ. (CPM)	5400	5400	5200	5600
MAX. AMPLITUDE AT RESONANCE (MILS)	11.9	6.2	16.1	7.3
DAMPING COEFFICIENT	≈ .002	.084		.079

V-2185

SUMMARY OF THEORETICAL VS MEASURED RESPONSE FOR LN₂ TEST ROTOR

ROTOR UNBALANCE, .149 OUNCE - INCHES

SPRING CONSTANT, K_s = 11,100 lb/in

	<u>THEORETICAL RESPONSE</u>		<u>MEASURED RESPONSE</u>	
	<u>UNDAMPED</u>	<u>DAMPED</u>	<u>UNDAMPED</u>	<u>DAMPED</u>
RESONANT FREQ. (CPM)	5400	5400	5200	5600
MAX. AMPLITUDE AT RESONANCE - (MILS)	11.9	6.2	16.1	7.3
DAMPING COEFFICIENT	≈ .002	.084		.079