

General Disclaimer

One or more of the Following Statements may affect this Document

- This document has been reproduced from the best copy furnished by the organizational source. It is being released in the interest of making available as much information as possible.
- This document may contain data, which exceeds the sheet parameters. It was furnished in this condition by the organizational source and is the best copy available.
- This document may contain tone-on-tone or color graphs, charts and/or pictures, which have been reproduced in black and white.
- This document is paginated as submitted by the original source.
- Portions of this document are not fully legible due to the historical nature of some of the material. However, it is the best reproduction available from the original submission.

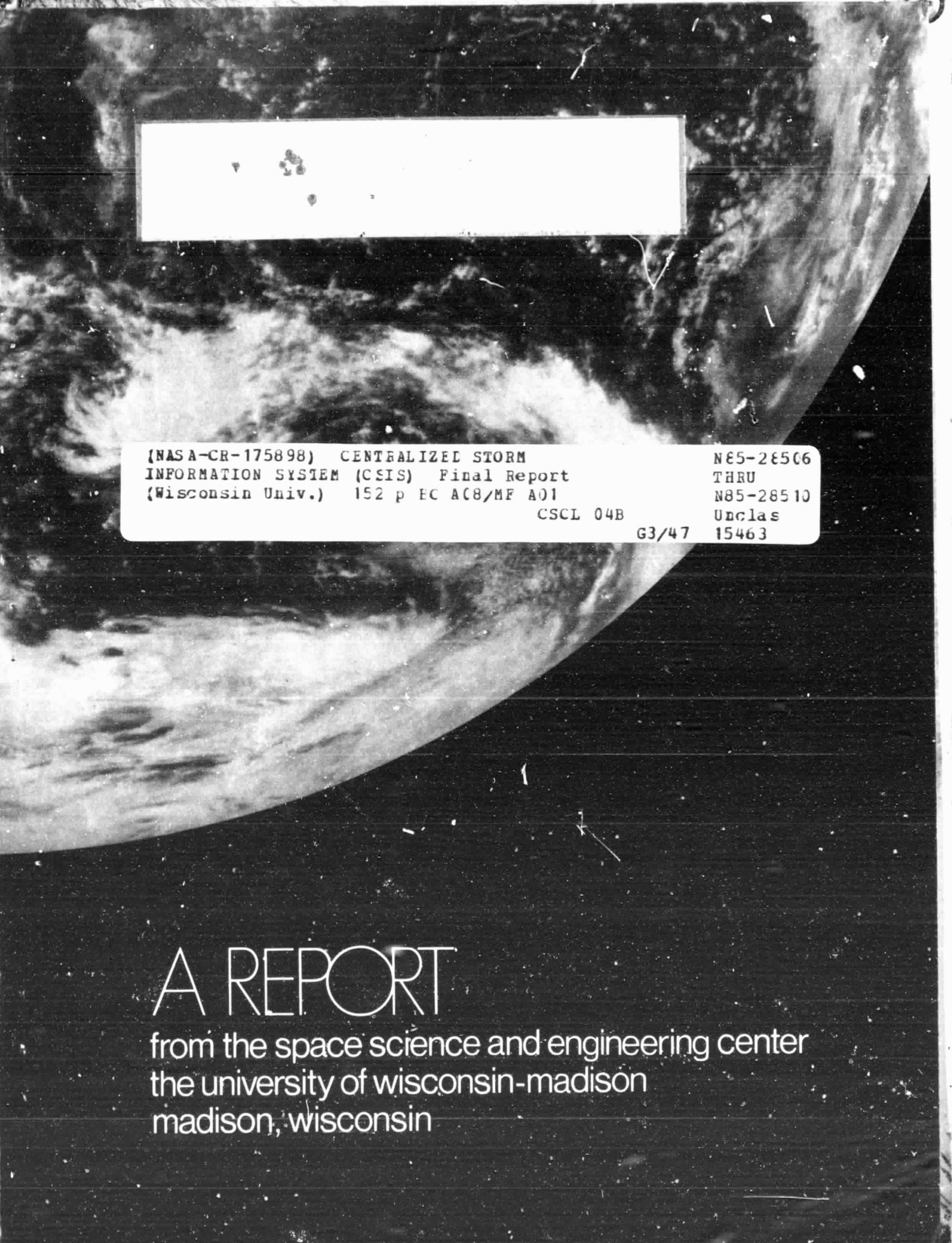

[Redacted]

{NASA-CR-175898} CENTRALIZED STORM
INFORMATION SYSTEM (CSIS) Final Report
{Wisconsin Univ.} 152 p EC AC8/MF A01

CSSL 04B

G3/47

N85-28506
THRU
N85-28510
Unclas
15463

A REPORT

from the space science and engineering center
the university of wisconsin-madison
madison, wisconsin

N85-28507

D1

Centralized Storm Information System (CSIS)
(Contract # NASW-3476)

A Final Report to the
National Aeronautics and Space Administration

Prepared by

Carl C. Norton ✓

Space Science and Engineering Center
at the University of Wisconsin-Madison
1225 West Dayton Street
Madison, WI 53706
(608) 262-0544

April 1985

Table of Contents

| | <u>Page</u> |
|--------------------------------------------------------------------------------------------------------------------------------|-------------|
| I. Introduction | 1 |
| II. CSIS Objectives | 1 |
| III. CSIS Hardware | 3 |
| IV. CSIS Software | 4 |
| V. Conclusion | 6 |
| VI. References | 7 |
| | |
| Appendix A: The CSIS at the NOAA Kansas City Complex | |
| Appendix B: Recent Technical Advances at the NSSFC That Will Improve Short Term Aviation Advisories | |
| Appendix C: Use of CSIS in Severe Weather Prediction | |
| Appendix D: Lessons Learned from CSIS | |
| Appendix E: Impacts of Interactive Processing Systems on the Forecasting Ability of the National Severe Storms Forecast Center | |
| Appendix F: CSIS Test and Evaluation | |
| Appendix G: Functional and Performance Requirements of the Next NOAA-Kansas City Computer System | |

I. INTRODUCTION

Operational forecasters have habitually been plagued with the problems associated with acquisition, display, and assimilation of data used in preparing forecasts. The necessity of performing these preliminary functions naturally detracts from the time available for thinking about the meteorological content of the data. The CSIS experiment provided an operational forecaster with an interactive computer system which could perform these preliminary tasks more quickly, accurately, and completely than any human could. Thus, using such a system should provide a forecaster time to examine more data and machine products that could not reasonably be made by hand (Anthony, R.W. et al., 1982; McCann, P.W. et al., 1983).

The unknowns were: Would the forecaster accept and utilize such a system; what would be the impact of such a system on an operational environment; and what are the optimum characteristics (hardware and software) of an operational system? These questions were answered by the CSIS experiment, and the lessons learned provided the basis for designing the next operational National Severe Storm Forecast Center (NSSFC) system. While some of the conclusions drawn from CSIS are specific to NSSFC, many can be extrapolated to other operational forecast environments.

II. CSIS OBJECTIVES

As stated in the "CSIS Implementation Plan" (SSEC 1981), the objectives of CSIS were:

- "(1) To improve the overall severe storms forecast and warning procedure, and
- (2) To demonstrate the operational utility of techniques developed with applied research environments."

With respect to the first objective, installation of an advanced interactive computer system had a positive impact on severe storm forecast and warning procedures (Ostby, F.P., 1984). Most obvious was the rapid replacement of radar by "real-time" satellite images as the primary data used to monitor development and movement of convection (Mosher et al., 1982; Mosher, F.R., 1985). The capability to improve the timeliness and quality of satellite and radar imagery and to superimpose these data on conventional analyses allowed forecasters to more easily assimilate and interpret data. This, when coupled with a ready means for tracking severe storms and extrapolating their motion, resulted in more accurate and more timely alerts to the public of potential or impending severe weather.

The second objective was achieved almost simultaneously with the CSIS installation. The initial system was nearly an exact copy of the McIDAS developed at the University of Wisconsin's Space Science and Engineering Center (SSEC), primarily for research. Although much of the software contained within the initial CSIS was not applicable to NSSFC operations, those programs which were applicable found immediate acceptance by the forecasters (CSIS Test and Evaluation - Final Report, NOAA/NESDIS, 1983).

As anticipated, the initial system did not satisfy all the desires of the forecasters. Increased utilization and dependence on the CSIS resulted in a continually updating list of desired software changes and new capabilities. A prioritized list of enhancements was worked on during the experiment by SSEC programmers, with the result that all of the highly desirable items and most of the lesser requirements were satisfied.

III. CSIS HARDWARE

The CSIS was installed and made functional in February, 1982 as scheduled. The system consisted of a GOES antenna system, three Harris Corporation computers with peripherals, two interactive workstations, and interface equipment. A third workstation was installed in April. (See the CSIS Implementation Plan, 1981, for a detailed description.)

The three-computer system was designed to operate in a fail-soft degraded mode. The CPU's were switchable between data base management and applications processor modes, so that failure of one computer did not bring down the entire system. Also, any workstation could be switched to any CPU. As a consequence of this design no total system down time was experienced due to computer failure.

The single exception to the scheduled installation was the auto dialer for the WBRR. The local telephone company would not allow the phone interface used by SSEC to be attached to their system. Purchase and modification of a commercial auto dialer had the WBRR working within two months of the system installation.

During the evolution of the CSIS experiment, several hardware additions/changes were made. The hardware addition which had the most impact on operations was the data tablet. Originally, the tablet was desired to facilitate input of coordinate information to the computer. However, its function was quickly expanded to include rapid key-ins of user-defined functions, using plastic overlays. The data tablets greatly improved the user friendliness of the CSIS workstations and dramatically reduced the time required to access data or prepare analyses and displays.

A system hardware addition was made as a result of the catastrophic disk failures which resulted in more than a week of down time. Most of the

down time was the result of attempting to re-install the system from tape. An additional 300 mb disk was installed to facilitate system saves, after it was found that the system could not be adequately saved on tape.

Several relatively minor hardware changes were made to the CSIS: The WBBR system was replaced by an interface to the Kavouras RADAC network; cooling fans were installed in the data concentrators; the workstations were insulated with soundproofing to reduce the forecasters' exposure to fan noise; and a black and white hard copy device was added to allow production of 8½ x 11 inch prints of the video images.

IV. CSIS SOFTWARE

Pre-delivery software development efforts for CSIS resulted in a system significantly different from the parent McIDAS. To ensure that future McIDAS developments could be readily transferred to CSIS, it was necessary to bring the two systems to a compatible state. To do this, the CSIS system was installed on the McIDAS network, allowing the user community to evaluate and debug the software. While this effort was traumatic for SSEC, it did result in a nearly trouble-free CSIS installation.

Phase I of CSIS was designed to allow forecasters to evaluate the existing McIDAS capabilities and to suggest modifications needed to enhance CSIS' operational utility. In this phase two remote workstations from the SSEC McIDAS were installed at NSSFC and made available to the forecasters for 3½ months. Phase II concentrated on the period following installation, but with the same objectives as Phase I. The result of these evaluations was a list of specifications of additional requirements for an operational interactive computer system (Mosher, F.R., 1984).

SSEC's response to this prioritized list of additional capabilities was an evaluation of the resources required (cost and time) to deal with each item. After reconsideration of priorities, a list was provided to the SSEC programming staff for software development. The following is a brief description of the more important system enhancements resulting from this process.

1. Watch box preparation was greatly facilitated by allowing the forecaster to create boxes on a satellite image or other map bases, using joystick control. The computer output the text required to describe location and dimensions of boxes.
2. A Service-A decoder was designed to extract remarks indicating severe weather. The remarks were then routed to all workstations to alert forecasters of the occurrences of severe weather.
3. County outlines were added to the graphics capabilities, aiding the forecaster in describing areas affected by impending or forecast severe weather.
4. A "help" function was included to aid occasional users who knew the desired command but not the necessary parameters.
5. Software required to operate the data tablet described earlier was written.
6. A pilot report decoder was written to flag reports of hazardous weather.
7. Installation of a $1/2^\circ$ grid interpolation system fixed the problem of analyses changing with different resolutions.
8. A missing data alarm was installed to alert forecasters to loss of 604 data.
9. An icing potential algorithm was encoded and installed on the CSIS.
10. A program to color enhance a satellite image as a function of location was written to delineate spatially varying phenomena such as the tropopause temperature.
11. Software was written to allow forecasters to view the effect of altering radiosonde plots.
12. A streamlined TV load program was written to lessen the impact of the numerous TV loads on the interactivity of CSIS.

13. The WBRR system was replaced by a better quality Kavouras RADAC system.
14. Software to accumulate statistics on frequency of use of the CSIS commands was developed.
15. The capability for forecaster modification of machine analyses was added to CSIS.

The above is not a complete list of the software changes made during the evolutionary phase of CSIS; nor does it include the numerous small modifications which were made almost continuously to enhance the system's utility.

V. CONCLUSION

The CSIS experiment was a success. A highly interactive computer system was provided for use by the forecasters of the NSSFC. Most of the forecasters readily accepted the CSIS and utilized its capabilities to enhance their forecasting prowess and to disseminate more accurate and timely severe weather forecasts.

A very significant conclusion derived from the CSIS experiment was the desirability of the "bottom up" design to evolve a usable operational system. Feedback from the personnel actually using the CSIS was utilized to determine the course of the system development, rather than any preconceived design. This resulted in a more ready acceptance of CSIS by the forecasters and a more truly operational system.

References

- Anthony, R.W., W.E. Carle, J.T. Schaefer, R.L. Livingston, A.L. Siebers, F.R. Mosher, J.T. Young, and T.M. Whittaker, 1982: The Centralized Storm Information System at the NOAA Kansas City Complex. Preprint Volume of the 9th Conf. on Weather Forecasting and Analysis, Seattle, Washington, June 28. July 1, 1982. Published by the American Meteorological Society, Boston, Massachusetts.
- McCann, D.W., E. Ferguson, M.D. Mathews, S.J. Weiss, A.L. Siebers, and J.L. Hobson, 1983: Recent Technical Advances at the National Severe Storms Forecast Center That Will Improve Short-Term Aviation Advisories. Preprint to the 9th Conf. on Aerospace and Aeronautical Meteorology, Omaha, NE, June 6-9, 1983. Published by the American Meteorological Society. 101-105.
- Mosher, F.R., 1984: Functional and Performance Requirements of the Next NOAA-Kansas City Computer System, National Severe Storms Forecast Center, Kansas City, MO. 1984.
- Mosher, F.R., 1985: Impacts of Interactive Processing Systems on the Forecasting Ability of the National Severe Storms Forecast Center. Preprint to the International Conference on Interactive Information and Processing Systems for Meteorology, Oceanography, and Hydrology, January 7-11, 1985, Los Angeles, California. Published by the American Meteorological Society.
- Mosher, F.R., and J.T. Schaefer, 1983: Lessons Learned from the CSIS. Preprints - 9th Conf. on Aerospace and Aeronautical Meteorology, Omaha, Nebraska. American Meteorological Society.
- Ostby, F.P., 1984: Use of CSIS in Severe Weather Prediction. Preprint from Recent Advances in Civil Space Remote Sensing, S.P.I.E. Vol. 481, 78-83.
- Siebers, A.L., J.T. Schaefer, R.W. Anthony, W.E. Carle, W.D. Hirt, D.W. McCann, K.C. McCarthy, 1983: CSIS Test and Evaluation - Final Report, NOAA/NESDIS.

APPENDIX A
TEST AND EVALUATION PLAN FOR THE
CENTRALIZED STORM INFORMATION SYSTEMINTRODUCTION

The Centralized Storm Information System (CSIS) will be installed in early 1982 at the NOAA operational complex, Federal Building, Kansas City, Missouri. For convenience, this complex which includes the National Severe Storms Forecast Center and a Satellite Field Service Station (SFSS) will be denoted in this plan as NSSFC. The CSIS represents a new and revolutionary development in information handling, intercomparison and display. With CSIS, computers will act in concert with forecasters to merge and analyze the myriad data sets needed to forecast severe convective storms. The primary purpose of CSIS is to demonstrate and evaluate real-time interactive computerized data collection, interpretation and display techniques as applied to severe weather forecasting. This plan sets forth an evaluation strategy so that CSIS will yield a specification of performance requirements and a functional design for the future operational interactive system at NSSFC.

The CSIS will consist of three computers, four interactive terminals, a satellite antenna, six data lines and a large briefing television. The system requires a minimum of two computers to operate. The third computer will normally be devoted to development work. However, if one of the primary computers is out of service owing to maintenance or failure, the third one can be transferred to the operational chain. The CSIS hardware will be a modified version of the University of Wisconsin Space Science and Engineering Center's (SSEC) Man-Computer Interactive Data Access System (McIDAS). A major development in the CSIS program will allow communication between CSIS and the NSSFC Eclipse Computer. Since the Eclipse will be interfaced to AFOS and NMC, CSIS will be integrated into the NWS operational system for the purpose of the test and evaluation as well as near term NSSFC support.

The CSIS software will be a modified version of that which drives McIDAS. This software has been undergoing development for approximately ten years. The modifications will permit testing and use of the CSIS system in the NOAA operational environment. Since CSIS is derived from the already functioning McIDAS, only a short shakedown period will be required between installation and operation.

A remote interactive terminal to the SSEC has been used by NSSFC since March 1980. This terminal was installed to evaluate satellite sounding techniques. However, it is available for data

analysis when it is not being used for the VAS evaluation. A second remote terminal was installed at NSSFC in mid-December 1987. This terminal is being used for pre-CSIS training and augments the NSSFC operational system. Because of the similarities between CSIS and McIDAS, experience and knowledge gained on these terminals will be directly transferrable to CSIS.

GOALS AND OBJECTIVES

The ultimate goal of CSIS and its operational successor is to make the overall severe storm forecast and watch procedures at NSSFC and services provided by SFSS-Kansas City more effective. Such an improvement can take several forms. It can be reflected in improved accuracy, timeliness, creation of new products or even in an increase in forecaster productivity.

Initially, CSIS will be primarily an information handling tool, operating upon presently available data. In later phases, CSIS will include ingestion of data from new sources such as VAS or NEXRAD. At first, CSIS will incorporate analysis and forecast techniques and procedures available through McIDAS. Development of new forecast techniques and procedures will be carried out during later phases of CSIS.

Throughout the course of the experiment, CSIS's primary function will be to assist the operational meteorologist in displaying, analyzing and intercomparing data sets in a timely, reproducible and easily comprehended manner. The use of modern technology will allow the forecaster to more fully use data and to apply theoretical concepts in the preparation of severe weather forecasts. The unique demands to be placed on CSIS are summarized in table 1.

Because weather prediction leans heavily upon theory, a viable forecast program requires constant infusion of new knowledge from the research community. Basic knowledge is distilled by applied research into proposed operational methods. NOAA must be able and willing to evaluate these techniques and to implement those which are truly helpful. This latter phase often requires an interactive computer system such as CSIS. A secondary goal of CSIS is to test and demonstrate the operational utility of techniques and procedures developed by applied research groups.

The specific objectives of the CSIS demonstration are more limited. The primary objective is to evaluate and establish the utility of an interactive system to the severe storm forecaster. A second objective is to use CSIS to establish the functional and performance requirements of an operational NSSFC interactive computer system. A third objective is to establish and evaluate

interface requirements between an interactive computer system and the evolving operational systems used by NOAA. With current rapid advances in technology, many new operational systems are either being implemented or anticipated (e.g., AFOS, NEXRAD, etc.). CSIS will complement the PROFS effort in this field.

FUNCTIONS, CRITERIA AND MEASURES

Specific aspects of CSIS will be evaluated against the CSIS objectives. The functions to be evaluated characterize the attributes of a generalized interactive computer system. Some of the items may not be part of the initial CSIS. Deficiencies (either inadvertently or intentionally omitted) as well as beneficial attributes of CSIS will be noted and fed back into improvements of CSIS, and/or into specifications for the future operational system. Although many of the measures are subjective, as much objectivity as is realistic and meaningful will be used. The functions can be broadly categorized as pertaining to system: (I) capabilities, (II) maintainability and (III) utility.

In the broad category of system capabilities, the following specifics will be examined and an analysis will be made which will be directed toward the specification for the operational system:

- Ia) System Reliability. An operational system must operate on a 168 hour a week basis. System failures or crashes must be infrequent and have a minimal impact. A log of CSIS downtime will be maintained. The generic (hardware, software, maintenance) and specific causes, seriousness, impact and duration of failures will be noted. Statistics on this information and the mean time between failures will be determined.

- Ib) System Monitoring and Control Procedures. An operational system must be reasonably simple to monitor and control. The amount and complexity of manual intervention necessary to keep the computer operating and ingesting data will determine the number and quality of computer operators necessary. Specific items that will be addressed are the ease of the system configuration for routine "rebooting" procedures, the complexity and speed of these procedures and the complexity of changing from a three to a two computer operation. Also, the quality and quantity of diagnostics indicating disfunctioning of the system will be examined. The criteria for evaluation of these

factors will be subjective and based upon the downtime log.

- Ic) System Protection. The operational system has to be protected against failure due to inadvertent actions by the meteorologist and system operators. An entry in the downtime log will document the specific actions that caused a CSIS system failure. The types, frequencies and impact of these crashes will be analyzed. A knowledge of the limitations and effectiveness of the system protection will result.

- Id) Data Acquisition. Meteorological data sets must be timely, complete and of high quality. To be useful, all observations including those taken at non-standard times (i.e., specials) must be accommodated. Subjective remarks as well as objective measurements are needed. Further, the quality of the data (conventional and satellite) should not be degraded by system ingest. Data timeliness and completeness will be automatically measured and statistics tabulated. The amount of degradation and data comprehensiveness will be estimated by comparing the CSIS data with that obtained by existing sources. The relative merits of alternate data input sources (i.e., WR604, AFOS, etc.) will be examined.

- Ie) Data Storage and Retrieval. The adequacy of the computer storage and the timeliness of data retrieval can be estimated from experience with the system. Also, the flexibility in data base management will become apparent after CSIS is in operation. The time needed to access various data types will be studied. A pertinent question that must be answered is how much data are lost due to system crashes. The amount of data recoverable after system failure will be examined. The downtime log will contain information on this aspect.

- If) Forecaster Machine Interface. The mechanical devices which allow computer interaction will be examined. CSIS will have joy-stick cursor and keyboard input. Questions as to the merits of this hardware will be addressed. Also, the ease with which the meteorologist can master the command language will be documented in the user documentation record. The quality of error messages and the ability of the system to "help" the user will also be noted.

- Ig) User Training. Questions as to the amount, degree and retainability of training will be answered. One pertinent aspect to be determined is whether training can be accomplished locally or must it be external.
- Ih) User Documentation. The user's manual must be complete, clear and understandable. These aspects will be evaluated. Suggestions for improvement will be made.
- Ii) External System Interfaces. The compatibility and ease with which CSIS can be integrated with existing and future operational systems will also be examined. The flexibility of the interfaces, the ability to shift to alternate data sources will be evaluated.
- Ij) Work Environment. Human engineering considerations of the system will be evaluated. Are the interactive terminals convenient to use? Is the hardware suitable to the problem? Can the equipment be used by all people (right- or left-handed, tall or short, etc)? Also, since the meteorologists will spend a significant portion of their time at the terminal, the fatigue factor, distractiveness of the equipment and its physical integration into the forecast environment will be evaluated.
- Ik) System Expansion. The amenability of CSIS to expansion will be evaluated. The ease with which new hardware and/or software is added during the course of the experiment will be documented.

The second broad grouping is system maintainability. Specific aspects to be examined are:

- IIa) Ease of Repair. A log will be kept which will document the time spent on system maintenance. Included will be the type and duration of preventive maintenance with comments on the complexity of procedures. When there is hardware failure, the cost of repair, the diagnosis time and the actual corrective time will be noted. Similarly, a log of software problems that includes diagnosis and corrective time will be maintained. Questions to be examined include which components fail, how often they fail, how easy they are to repair and how critical their failure is to CSIS.

IIb) Hardware Documentation. The extent and sufficiency of the documentation will be noted. Comments as to its adequacy to support future modification will be made. The necessary level of expertise of the electronic technician who is responsible for the future operational system will be estimated.

IIc) Software Documentation. The extent and clarity of software documentation will be evaluated. Comments as to its adequacy to support future modification or additions will be made. The level of programming expertise needed in order to make software additions will be noted.

Under the category of system utility, various aspects of the application of an interactive computer system to severe weather forecasting will be addressed. Specifics to be documented on a shift log are:

IIIa) Presentation and Display. The characteristics of the presentation and display capability of the system will be examined. The adequacy of labelling of the display will be noted. The sufficiency of enhancement capabilities and gray scales to delineate fine detail in satellite imagery will be assessed. An idea of the number of image and graphic frames desirable in a future operational system will be obtained. Animation capabilities will be evaluated. Erasure characteristics and limitations will also be examined.

IIIb) Data Quality Control. Statistics as to the amount and types of data automatically flagged as erroneous will be collected. An evaluation of the manner that the system recognizes and modifies (or deletes) bad data will be made. Manual quality control capabilities will also be examined. The ability to meld various data from compatible, but different sensors will be examined.

IIIc) Data Analysis. Evaluation of the variety and timeliness of data analysis will be made. The RMS and algebraic error of analyses will be objectively computed. The reasonableness of patterns will be noted.

- IIIId) Derived Quantities. The comprehensiveness, timeliness, and operational utility of derived fields (i.e., moisture convergence, positive vorticity advection, etc.) will be examined.
- IIIe) Format Transformations. The capability to transform the format of various analyses and data sets so that a uniform and combined presentation can be made will be examined. The sufficiency, timeliness, adaptability, quality and clarity of the transformations will be evaluated.
- IIIIf) Integration of Analyses. The capability to superpose various analyses will be examined. The flexibility, timeliness and needs of the meteorologist for such integration will be noted. Experience will allow determination of the number of color and contour options necessary to superimpose an operationally determined number of fields.
- IIIIg) Local Product Preparation. CSJS will be integrated into the operational structure at NSSFC. The compatibility of CSIS generated fields with conventional data sets will be examined. The use of CSIS to determine watch positioning and storm report locations will be explored.
- IIIHh) Simple Models. The capability to use simple models to extrapolate the centroid, area of coverage and other significant features of meteorological phenomena will be examined. The availability, timeliness and utility of such models will be documented.
- IIIii) Development of Operational Procedures. The utility, adaptability, flexibility and comprehensiveness of the operating procedures will be examined. The development and documentation of a routine operational procedure will be an ongoing task. This will evolve from a preliminary procedure developed during the first month of the CSIS test. The ease of deviating from the rote in developing situations will be evaluated.

OPERATIONAL ASPECTS OF THE CSIS EXPERIMENT

The principal organizations involved with operational aspects of the CSIS program are the NWS-National Severe Storms Forecast Center (NSSFC) and the NWS Kansas City Satellite Field Services Station (SFSS).

The NSSFC is subdivided into semi-autonomous units, each with a distinctive mission and unique responsibility. Two of the operational units will play a major role in the experiment. These units are the Severe Local Storms Forecast Unit (SELS) and the National Aviation Severe Storms Advisory Unit (SIGMET).

SELS issues tornado and severe thunderstorm watches for the contiguous 48 states. This unit also continually monitors thunderstorm activity and issues outlooks for severe and general thunderstorms for periods up to 24 hours.

SIGMET issues hourly bulletins to aviation interests for in-flight hazardous convective weather phenomena over the contiguous 48 states. This unit routinely plots hourly radar reports.

The mission of the Kansas City Satellite Field Services Station (SFSS) is to receive, process and interpret data provided by the NOAA operational satellite system. The SFSS is responsible for the timely relay of information derived from satellite data to both NSSFC and to others in a 21 state area of responsibility. To realize the goals of this mission, the SFSS continuously monitors all cloud systems, determines the direction and speed of movement of weather systems and assesses change in cloud patterns.

Other NOAA groups who will have access to CSIS on a time available basis, but will not participate directly in the evaluation, include an Aviation Forecast Unit with a six state area of responsibility, and the National Public Service Unit which prepares weather summaries for nationwide mass media dissemination. Features of CSIS which could be of potential benefit to these units will be noted during the test and evaluation.

In pursuing their mission, each of the three major participating units (SELS, SIGMET, SFSS) perform specific tasks. These tasks can be considered as belonging to one of five groups. The groups are synoptic overview, routine upper air analysis, weather monitoring, time-triggered product preparation, and crisis (non-scheduled) product preparation. For each unit, these tasks are interrelated by the schematic flow diagram of Figure 1. Table 2 indicates the tasks which each unit performs in each group.

Since CSIS (and its operational successor) will be integrated into the NSSFC forecast system, it will not be responsible for all the tasks listed. The AFOS, the NSSFC computer system (an Eclipse S 230 and a Varian minicomputer) and

other existing weather service systems are designed to perform the synoptic overview groups and the composition/dissemination portions of the product preparation groups. Thus, quite logically they will be responsible for such tasks. Also long, computationally-involved jobs will continue to be run on the NSSFC computer or NOAA's IBM 360/195 system, if necessary. The routine upper air analysis and weather monitoring groups as well as decision phases of product preparation, will be the domain of CSIS. Use of CSIS must be guided by the concept that it is highly desirable to hold processing time to a minimum on interactive computer systems.

EVALUATION STRATEGY

The evaluation strategy arises from a knowledge of the CSIS functions constrained by the NSSFC severe storm mission. The routine upper air analyses are performed over the North American continent. During the two hours immediately following rawinsonde time, all 27 tasks of the SELS routine analyses must be completed. Several of the tasks require multiple (>10) fields be analyzed. Further, during these periods, the weather monitoring tasks must also be performed and the NSSFC workload is the heaviest.

From the 00Z routine analysis, a time triggered product (the convective outlook) is produced. This outlook determines the "problem of the day". The location, risk and synoptic forcing of the likeliest severe weather threat is specified. While the meteorological fields examined are relatively constant irrespective of the situation, the scale of greatest concentration of effort changes. For example, during dryline situations an area of about 100,000 square nautical miles is typically threatened. At the other extreme, northwest flow weather systems commonly affect areas of greater than 300,000 square nautical miles. The continuing weather monitoring tasks concentrate on the appropriate scale.

Moreover, monitoring must continue over the entire country. For example, more than one threat situation often exists, or developing weather patterns can produce new, previously unexpected problem areas. Also, the scale changes as the weather develops. While the watch is based upon mesoscale analysis, the status report relies upon storm-scale data. The ability to change scales and areas is mandatory. In fact, this is one major advantage that CSIS has over the present system.

Severe convective storm forecasting is based upon a limited set of analyses. Major day-to-day changes are in scale and location. Thus, the evaluation can proceed on a unified strategy, with the final report structured under a stratification

by synoptic type. A user documentation record (UDR) (Figure 2) will be maintained for each shift during the experiment. All the CSIS utilization functions are listed and the criteria will be subjectively rated on an A to F scale (4 to 0). For each report the distribution of the grades for each aspect will be used to designate the features of CSIS which are not operationally useful. Also listed on the UDR is automatically collected information on the programs executed. Compiling this information will yield data relating to the types of analysis most frequently used in various synoptic situations.

The UDR will contain space for a discussion of the system characteristics which effect the meteorologist. This information will be verbal rather than numerical so that a "feeling for the problems" can be obtained. With these aspects, forecaster response is the guiding factor.

During the evaluation, three logs will be maintained. They are a downtime log, maintenance log and a software log. The general form is indicated in Figures 3, 4 and 5. All contain quantifiable information and are rather self explanatory. The UDR and the three logs will be quality controlled daily throughout the course of the evaluation. The results will be summarized on a weekly and monthly basis in order to insure the integrity of the project. Computer generated statistics on average data completeness, timeliness and analysis accuracy mentioned previously will be collected monthly during the experiment.

In addition, the SFSS will routinely note instances when the system yields specific mission-oriented insights into non-severe convective events. Records will be maintained of all instances where unique knowledge (i.e., knowledge that would have been unavailable without the benefit of an interactive system) is provided. Verification will be performed to determine if solutions to problems obtained from the system were satisfactory and accurate. Specifically, this SFSS project will include information on the value and utility of CSIS derived information as it applies to heavy snowfall, fruit frost, excessive precipitation and the fog/stratus forecast problems.

CSIS EVALUATION SCHEDULE AND REPORTING

The CSIS evaluation time schedule is constrained by the equipment installation dates, the budget cycle and severe storm climatology. CSIS itself will not be installed until at least January 1982. Experience indicates that a shakedown period is necessary for a computer system to operate in a satisfactory and reliable manner. Further, the bulk of the severe weather season lasts until late June. Thus, evaluation from a severe weather

viewpoint should not be made until spring 1983. However, this schedule is totally unrealistic owing to budget constraints. A compromise is necessary.

Three evaluation reports will be completed (Table 3). Each of the reports will contain a matrix of design specifications which, based upon CSIS experience, are needed for development of an operational interactive system. The first evaluation period will begin on 1 April 1981 and end on 15 July 1981. This period will include one severe weather season. The first report will be completed for use as input to the FY 1984 budget initiative in October 1981. Since this report will be based on McIDAS experience, it cannot cover all elements. In Table 1, numbers 2, 4, 8, 9 and 10 cannot be addressed. Thus, the first report will only cover three items from I [system characteristics (d, h, f)] and all items of III [system utility]. The remainder of the evaluation measures are not pertinent in this pre-CSIS stage.

Since the McIDAS installation at SSEC is fully staffed only on an eight hour, five day a week basis, evaluation time will be severely limited. This will necessarily bound the aspects of the NSSFC program that can be examined during this first evaluation period. The busiest time at NSSFC is the two hours after each rawinsonde release time (00Z and 12Z). Unfortunately, for this report only part of the two hour period following the 12Z release can be examined because of SSEC staffing considerations. Further, during the morning hours severe weather is at a diurnal minimum and the monitoring task is of lesser importance.

The second report will be ready in time for the 1984 Congressional Budget Defense. This evaluation will cover the remainder of the pre-CSIS experiment and the first portions of CSIS. The system will be developing during this period. However, many of the salient features of CSIS can and must be examined. The pre-CSIS time will be used to further examine CSIS impact (on an 8-hour a day basis) on SELS, SIGMET and SFSS. This portion of the examination will be restricted to the same elements as the first report. When the CSIS is implemented, an evaluation of all 23 items will commence on a 168 hour-a-week basis. With this "around the clock" coverage the full CSIS impact upon NSSFC can be assessed.

The final evaluation report will be completed during the summer of 1983. During the last three months of the evaluation period (March, April, and May - a good portion of the severe weather season), the CSIS software will be frozen. No development of the operational equipment will occur. From this evaluation, a detailed specification of the hardware and software requirements for the NOAA-Kansas City operational replacement of CSIS can be obtained.

Reports will be sent to NOAA Headquarters, NWS Headquarters, NESS Headquarters, NASA Headquarters, SSEC, and ERL Headquarters. Copies of the report will also be sent to appropriate subgroups within these organizations.

DIRECT PARTICIPANTS IN TEST

A special CSIS meteorological unit (CMU) will be established to do the test and evaluation. During pre-CSIS, it will be staffed on an 8 hour, 5 day week basis. With CSIS installation, the CMU will be needed 168 hours a week. The CMU meteorologists will perform the evaluation. Also, they will have the primary responsibility for system operation, system utilization and the development of operational procedures. These individuals will maintain the logs and the UDR. By acting as advisors to the operational units, the CMU staff will be intimately involved in the forecast process and be able to have the UDR reflect the comments and benefits realized by the forecasters. Non-routine system operation (i.e., restarting the system after soft failures) will also be their responsibility. The CMU will remain in existence for the duration of the CSIS experiment. After the experiment is completed and the operational successor to CSIS is installed, CMU personnel will be assimilated into other units.

The Electronic Data Processing Unit (EDP) computer operators responsible for the NSSFC Data General Eclipse computer system will perform routine support services such as tape mounting. The NSSFC Electronics Technician Staff (E.T.) will oversee the maintenance of the hardware and diagnose the causes of failure. The Techniques Development Unit (TDU) will be responsible for developmental work on CSIS. This will involve the design, development, implementation and testing of new analysis and forecast techniques. These techniques will go beyond those supplied with CSIS and will be aimed at expanding the scope of the project in the areas of data retrieval and display. CSIS project reports will be prepared under the guidance of the Chief, TDU.

RESOURCES REQUIRED

NSSFC has space and air conditioning available for the CSIS system. Recurring expenses not covered in the SSEC contract for the system (mostly paper and electricity) will be minimal. This plan has been written under the assumption that the following staff will be available by the dates specified:

| | | |
|--------------------------|-------|------|
| 1 meteorologist | April | 1981 |
| 1 electronics technician | June | 1981 |

1 computer specialist
4 meteorologists

December 1981
January 1982.

FIGURE 1
GENERALIZED FLOW OF NSSFC SHIFT

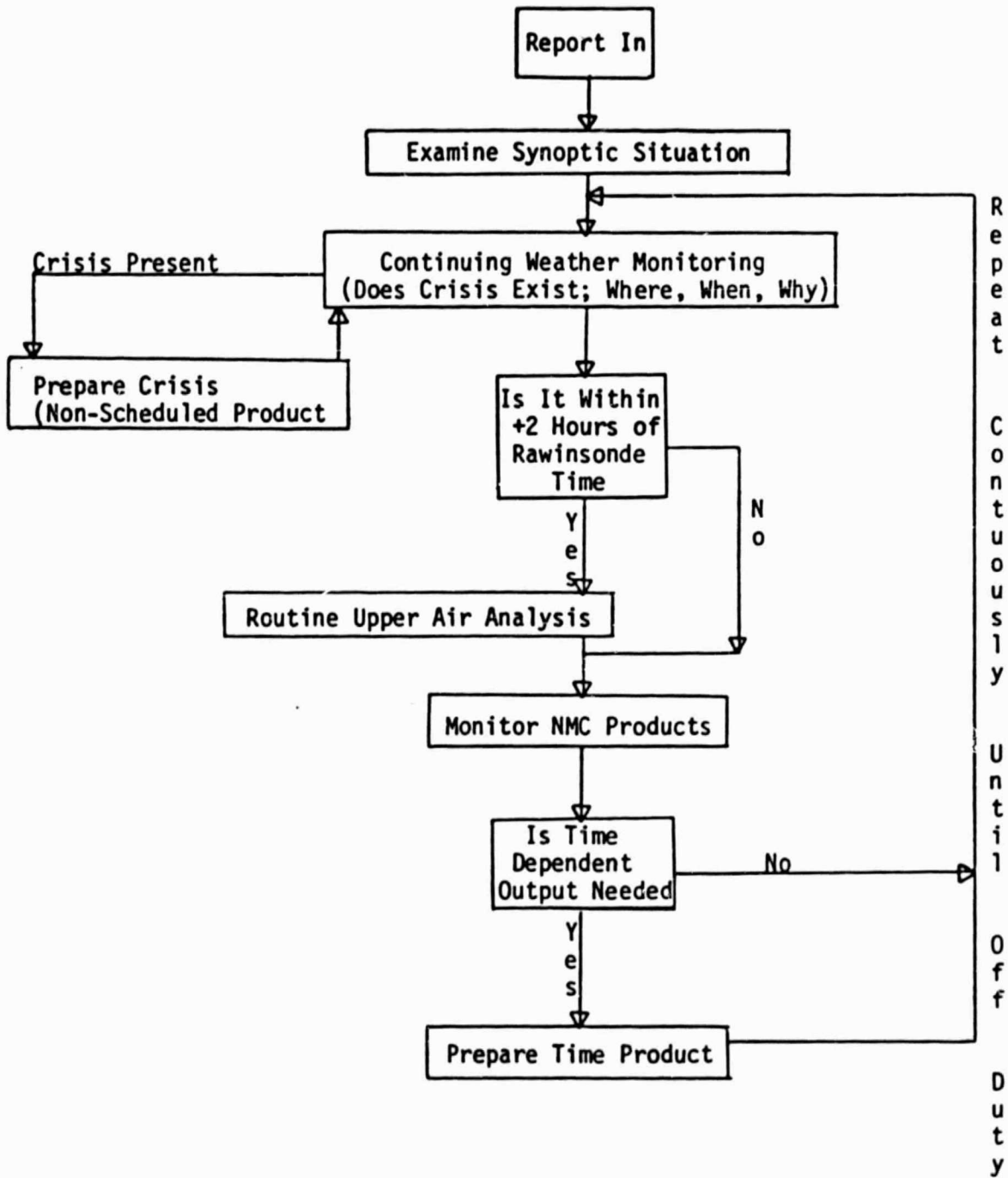

Figure 2

User Documentation Record

Operating Problems (Control language, physical layout,
poor documentation, etc)

Day _____
 Shift _____
 CMU _____
 SELS _____
 SIGMET _____
 SFSS _____
 Problem of Day _____
 Areas of Interest _____

Meteorological Problems (Data Comparison, Analysis
Comparison, etc)

Programs Executed

| Function | Field | Area | Duration (Time From Que In to Completion of Output) | Terminal | No. of Times Executed |
|-----------------------------------------------------------|-------|------|-----------------------------------------------------------|------------------------|--------------------------|
| | | | | Grade (A through F) | <u>Comment</u> |
| <u>Qualities</u> | | | | | |
| Display Characteristics | | | | | |
| Adequacy of Labelling | | | | _____ | |
| Contrast (subtle cloud details visible) | | | | _____ | |
| Zoom (time needed to change scale) | | | | _____ | |
| Erasure (availability, usefulness) | | | | _____ | |
| Number of Graphics Available (if more needed comment) | | | | _____ | |
| Number of Images Available (if more needed comment) | | | | _____ | |
| Animation Characteristics (length, refresh rate, etc.) | | | | _____ | |
| Data Quality Control | | | | | |
| Quality of Automatic Data Q.C. | | | | _____ | |
| Ease of Modifying Bad Data | | | | _____ | |
| Ease of Bogusing Data | | | | _____ | |
| Timeliness of Data | | | | _____ | |
| Data Analysis | | | | | |
| Adequacy of Analysis | | | | _____ | |

Figure 3

Downtime Log

| Time Down | Time Up | Cause | Impact | Amount of Data Lost | How Noticed |
|-----------|---------|-------|--------|---------------------|-------------|
| | | | | | |

Figure 4

Hardware Maintenance Log

| Problem | Time to Diagnose | Time to Repair | Type (P.M. or "Crash") | Cost | Comments on Documentation |
|---------|------------------|----------------|------------------------|------|---------------------------|
| | | | | | |

Figure 5

Software Maintenance Log

| Problem | Age of Program (Months) | Time to Diagnose | Time to Correct | Comments of Documentation, Modularity, etc. |
|---------|-------------------------|------------------|-----------------|---------------------------------------------|
| | | | | |

TABLE 1
OPERATIONAL DEMANDS ON CSIS

- (1) Earlier receipt of data and/or analysis.
- (2) Quality control of computer data base.
- (3) Derived variables not readily available elsewhere.
- (4) More detailed and versatile data displays.
- (5) Overlay different analysis.
- (6) Improve understanding of situation.
- (7) Faster recognition and/or solution of impending crisis.
- (8) Interface with other users.
- (9) Develop new forecast techniques.
- (10) Test and evaluate new forecast techniques.

TABLE 2 (Page 1)
 TASKS PERFORMED BY NSSFC/NESS OPERATIONAL UNITS
 Examination of Synoptic Situation - Part 1

| <u>SELS</u> | <u>SIGMET</u> | <u>SFSS</u> |
|----------------------------------|---------------|-------------|
| History of Current Pattern | * | * |
| NMC Hemispheric Surface Analysis | * | * |
| NMC U.S. Surface Analysis | * | * |
| NMC Hemispheric 500 mb Analysis | * | * |
| NMC Hemispheric 300 mb Analysis | * | * |
| LFM Model Output | * | * |
| Barotropic Model Output | * | * |
| Spectral Model Output | * | * |
| TDL MOS Output | * | * |
| NMC Surface Forecast | * | * |
| NMC 3-5 Day Forecasts | | |
| NMC 6-10 Day Forecasts | | |

TABLE 2 (Page 2)
 TASKS PERFORMED BY NSSFC/NESS OPERATIONAL UNITS
 Continuing Weather Monitoring - Part 2a

| SELS | SIGMET | SFSS |
|-------------------------------------------------------|--------|------|
| A) Obtain Surface Observations | * | * |
| B) Obtain Radar Data | * | * |
| C) Obtain Visual Satellite | * | * |
| D) Obtain Infrared (IR) Satellite Data | * | * |
| E) Obtain Other Teletype Products | * | * |
| F) Obtain NMC Products Quality Control A through F | * | * |
| G) Analyze Surface Wind Field | * | * |
| H) Analyze Sea Level Pressure | * | * |
| I) Analyze Surface Temperature | * | * |
| J) Analyze Surface Dewpoint | * | * |
| Analyze Surface Geostrophic Wind | * | * |
| Analyze Surface Moisture Convergence | * | * |
| Analyze Surface Features | * | * |
| Analyze Surface Pattern | * | * |
| Analyze Time Changes of G, H, I, J | * | * |
| Analyze Surface Lifted Parcel Temperature | * | * |

TABLE 2 (Page 3)
 TASKS PERFORMED BY NSSFC/NESS OPERATIONAL UNITS
 Continuing Weather Monitoring - Part 2b

| SELS | SIGMET | SFSS |
|--------------------------------------------------|--------|------|
| Monitor Weather or Surface Observations | * | * |
| Monitor Winds on Surface Observations | * | * |
| Monitor Remarks on Surface Observations | * | * |
| Examine Large Scale Radar Pattern | * | * |
| Examine Large Scale Satellite IR Pattern | * | * |
| Examine Large Scale Satellite Visual Pattern | * | * |
| Monitor Detailed Satellite Imagery | * | * |
| Synthesize all Analyses | * | * |
| Compare Present Pattern With Forecast Fields | * | * |
| Monitor Special/Severe Weather Statements | * | * |
| Collect Severe Reports | | |
| Maintain/Monitor Activity Chart | * | |
| Code Report Verification Log | | |
| Maintain KCRT Files of Severe Reports for NWS Hq | | |
| Monitor State Forecasts (FP1) | * | * |

TABLE 2 (Page 4)
 TASKS PERFORMED BY NSSFC/NESS OPERATIONAL UNITS
 Continuing Weather Monitoring - Part 2c

| SELS | SIGMET | SFSS |
|-----------------------------------------|--------|-----------------------------------------------------------------------|
| Monitor FP3's | * | * |
| Coordinate With Other Internal Units | * | * |
| Analyze Surface Weather | | |
| Analyze Cloud Chart | | * |
| Monitor PIREPS | | |
| | | Correlate cloud patterns conventional meteorological parameters |
| | | Compute motion of cloud features |

TABLE 2 (Page 5)
 TASKS PERFORMED BY NSSFC/NESS OPERATIONAL UNITS
 ROUTINE UPPER AIR ANALYSIS - Part 3a

| SELS | SIGMET | SFSS |
|-----------------------------------------------------|--------|------|
| Ingest Upper Air Data | * | * |
| Quality Control Upper Air Data | * | * |
| Analyze 850 mb Data @ | * | * |
| Analyze 700 mb Data @ | * | * |
| Analyze 500 mb Data @ | * | * |
| Analyze 250 mb Data @ | * | * |
| Analyze Tropopause Temperature | * | * |
| Analyze Tropopause Height | * | * |
| Analyze Upper Jet Stream | * | * |
| Analyze Showalter Index | * | |
| Analyze Vertical Totals | * | |
| Analyze Cross Totals | * | |
| Analyze SWEAT Index | * | |
| Analyze 850-500 mb Thickness | * | * |
| Analyze 850-500 mb Shear Wind | * | * |
| Analyze Expected Surface Temperature due to Heating | * | |
| Analyze Positive Area Field | * | |
| Analyze Negative Area Field | * | |
| Analyze Mean Low Level Mixing Ratio Field | * | * |
| Analyze Contours of Wet-Bulb Zero Height | * | |

TABLE 2 (Page 6)
 TASKS PERFORMED BY NSSFC/NESS OPERATIONAL UNITS

ROUTINE UPPER AIR ANALYSIS - Part 3b

| SELS | SIGMET | SFSS |
|-------------------------------------|--------|-----------------------------------------------------------------------------------------------------------------------------------------------------------------------------------------------------------------------------------------------------------------------------------|
| Analyze SELS Lifted Index | * | |
| Analyze Maximum Low Level Wind | * | |
| Analyze Maximum Mid Level Wind | * | |
| Analyze Mean Tropospheric Wind | * | |
| Analyze Mean Upper Level Divergence | * | |
| Construct SELS Composite Chart | | |
| Plot Individual Soundings | * | Analyze snow cover as depicted in satellite imagery Locate and Plot 0°C surface isotherm from infrared data Determine probable areas of active snow melt Provide FA with location and movement of low cloud edges Analyze satellite rawinsonde cloud top height chart |

@ Note this analysis includes the following: (1) geopotential, (2) temperature, (3) dewpoint, (4) wind speed, (5) wind direction, (6) vorticity, (7) advection of 1-6, (8) time changes of 1-5, (9) patterns of 1-8, and (10) divergence.

TABLE 2 (Page 7)
 TASKS PERFORMED BY NSSFC/NESS OPERATIONAL UNITS

Time Triggered Product Preparation - Part 4

(Items marked by @ are decisions which arise from monitoring)

| SELS | SIGMET | SFSS |
|--------------------------------------------------------------------|-----------------------------------------------|------------------------------------------------|
| @Layout Proposed Convective Outlook (AC) General Thunderstorm Area | @ Layout Proposed Convective SIGMETs (WS1) | Compose Satellite Interpretation Message (SIM) |
| @Layout Proposed AC Severe Thunderstorm Area | Finalize WST Points | Transmit SIM |
| Determine Severe Risk Category | @Determine Which Zones They are in (W,C or E) | Prepare Satellite Summary Chart |
| Finalize AC Area Points | @Define States Involved | Provide Chart to SELS with Verbal Briefing |
| @Define States Involved | @define Movement | |
| Compose AC Message Including Narrative | @Define Maximum Tops | |
| Transmit AC | Determine Forecast Trend and Severe Potential | |
| Code AC Verification Log | Transmit WST | |
| | Coordinate With Appropriate WSFO's or CWSU's | |

TABLE 2 (Page 8)
TASKS PERFORMED BY NSSFC/NESS OPERATIONAL UNITS

Crisis (Non-Scheduled) Product Preparation - Part 5a
(Items marked by @ are decisions which arise from monitoring)

| SELS | SIGMET | SFSS |
|---------------------------------------|-------------------------------------------------------|--------------------------------------------------------------------------------------------------------------------------------------------------------------------|
| @ Decide Type of Watch (MW) | Determine if Unexpected Convection Meets WST Criteria | Provide SELS with Location and Trend of Boundaries, Trigger Mechanisms and Features Precursory to Convective Development for use in Watch Location and Orientation |
| @ Layout Proposed MW | | |
| Coordinate with WSFO's/NHC/NMC | Prepare (as in Part 4) Special WST | |
| Finalize MW Location | | |
| @ Define End Points | | |
| @ Define Width | | |
| Define Issue, Valid and End Times | | Advise WSFOs and RFCs of Potential for Flash Flooding as Suggested by Satellite Data |
| Prepare Aviation MW (AMW) | | |
| Transmit AMW | | |
| Define Maximum Expected Wind Gust | | |
| Define Maximum Expected Hail Size | | |
| Define Cloud Tops | | |
| Define Expected Mean Cloud Layer Wind | | |
| @ Define End Point Coordinates | | Advise SELS of how Convection Relates to the Valid Watch(s) and of Conditions that Suggest a Need for Additional Watch |
| Compose MW Message | | |
| Transmit MW | | |
| Prepare Radar (FAX/AFOS) Message | | |
| Transmit Radar (FAX/AFOS) Message | | |

TABLE 2 (Page 9)
 TASKS PERFORMED BY NSSFC/NESS OPERATIONAL UNITS
 Crisis (Non-Scheduled) Product Preparation - Part 5b
 (Items marked by @ are decisions which arise from monitoring)

| <u>SELS</u> | <u>SIGMET</u> | <u>SFSS</u> |
|-----------------------------------|---------------|-------------|
| Code Match Verification Log | | |
| Determine if AC is Still Valid | | |
| Amend AC if Necessary | | |

TABLE 2 (Page 10)
 TASKS PERFORMED BY NSSFC/NESS OPERATIONAL UNITS

Crisis (Non-Scheduled) Product Preparation - Part 5c
 (Items marked by @ are decisions which arise from monitoring)

| SELS | SIGMET | SFSS |
|-------------------------------------------------------------------------------|--------|--------------------------------------------------------------------------------------------------------------------------|
| Compose Status Report (WW-A) and All-Clear Message | | Prepare SIM Updates as Needed |
| Transmit WW-A | | Transmit Updated SIM |
| Compose Special Statement (WWUS-9) Detailing Unusually Severe Weather Threats | | Provide Convective SIGMET Unit with Satellite Interpretation of Location, Trends and Height of Significant Thunderstorms |
| Transmit WWUS-9 | | Provide SELS Unit with Information Derived from Satellite Data that Relates to Severe Thunderstorm Development |
| Determine if WW Cancellation is Needed | | Interface with WSFOs and River Forecast Centers |
| Compose Cancellation Message | | Estimated Precipitation Amounts Derived from Infrared Satellite Imagery and Potential Flash Flood Areas |
| Transmit Cancellation Message | | Coordinate with NWS Field Offices on Unique and Pertinent Information Derived from Satellite Data |
| Coordinate With WSFO's/NHC | | |

TABLE 3
REPORTING FRAMEWORK

| <u>USE</u> | <u>PREPARATION PERIOD</u> | <u>EVALUATION PERIOD</u> | <u>SYSTEM STATUS</u> | <u>ASPECTS EVALUATED</u> |
|---------------|---------------------------------|---------------------------------------|----------------------|--------------------------|
| First Report | 1984 Budget Initiative | Summer 1981 | McIDAS | Id, Ih, If, All of III |
| Second Report | 1984 Congressional Defense | Summer 1982 | McIDAS | Same as First Report |
| Final Report | Detailed Contract Specification | Summer 1983 | CSIS Shakedown | All 23 |
| | | 15 July 1981 through Mid-January 1982 | | |
| | | Mid-January 1982 through 15 July 1982 | CSIS Shakedown | All 23 |
| | | 15 July 1982 through 28 February 1983 | Developing CSIS | All 23 |
| | | 1 March 1983 through 31 May 1983 | Frozen CSIS | All 23 |

U.S. DEPARTMENT OF COMMERCE
NATIONAL OCEANIC AND ATMOSPHERIC ADMINISTRATION
NATIONAL WEATHER SERVICE
(National Severe Storms Forecast Center)

and

NATIONAL EARTH SATELLITE DATA AND INFORMATION SERVICE
(Satellite Field Service Station - Kansas City)

CSIS TEST AND EVALUATION -- FINAL REPORT

OCTOBER 1983

A.L. Siebers
J.T. Schaefer
R.W. Anthony
W.E. Carle
W.D. Hirt
D.W. McCann
K.C. McCarthy

CSIS TEST AND EVALUATION -- FINAL REPORT

TABLE OF CONTENTS

| | |
|----------------------------------------------------|----|
| Executive Summary | 1 |
| Introduction | 3 |
| CSIS Hardware | 4 |
| Operational Evaluation | 7 |
| System Reliability | 14 |
| System Monitoring and Control Procedures | 15 |
| System Protection | 15 |
| Data Acquisition | 16 |
| Data Storage and Retrieval | 18 |
| Forecaster-Machine Interface | 20 |
| User Training | 21 |
| User Documentation | 21 |
| External System Interface | 22 |
| Work Environment | 22 |
| System Expansion | 23 |
| Ease of Repair | 24 |
| Hardware Documentation | 24 |
| Software Documentation | 25 |
| Presentation and Display | 25 |
| Data Quality Control | 28 |
| Data Analysis | 29 |
| Derivative Quantities | 30 |
| Format Transformations | 31 |
| Integration of Analyses | 32 |

| | |
|-------------------------------------------------|----|
| Local Product Preparation | 32 |
| Simple Models | 33 |
| Development of Operational Procedures | 33 |
| Summary | 36 |
| Figure 1 | 39 |
| Figure 2 | 40 |
| Appendix A | 41 |

CSIS TEST AND EVALUATION -- FINAL REPORT

EXECUTIVE SUMMARY

This report covers the period from February 1982 when the CSIS system was installed at NSSFC through June 1983.

CSIS has had a dramatic and positive impact on the operations of the NSSFC. The continued evolution of the system to meet the needs of NSSFC has produced a high degree of forecaster acceptance and dependence on CSIS. While verification statistics for such a short term must be interpreted with caution, these indicate that the proportion of severe weather watches which were verified reached an all time high in 1982. Watch verification for 1983 has remained near the record 1982 level.

The evolutionary "bottom up" design philosophy of CSIS has resulted in many changes to the system. During the reporting period, over two hundred new programs and 400 program modifications have been implemented. The system has evolved in response to individual forecaster's needs and desires. This has resulted in improved system efficiency and acceptability.

The most significant operational features of the system include:

- o timely and flexible presentation of satellite imagery
- o color enhancement of satellite imagery

- o access to conventional surface and upper air data
- o ability to superpose data and analyses on satellite imagery
- o capability to schedule commands for execution
- o ability to create derived quantities (divergence or advection of a parameter, time and level changes)
- o capability of creating unique analyses via manipulation of gridded data
- o location of points on the satellite imagery using various coordinates
- o macro language facility for defining a sequence of commands
- o availability of simple models
- o modular work stations
- o color graphics.

Several significant enhancements to CSIS have yet to be evaluated, including:

- o ingest of Kavoris type radar data
- o link to NSSFC computer system
- o ingest of lightning strike data.

The capabilities found to be needed in an operational interactive computer system over and above those of CSIS include:

- o increased processing capabilities to allow greater interactive usage

- o additional image and graphic frames
- o 8 bit display capability for image frames
- o individually eraseable graphics
- o capability to perform 0.5 degree grid analyses for entire U.S.

CSIS represents a major step toward providing the operational meteorologist a truly interactive, information handling and display system. It was also the driving factor in determining the potential for "high tech" data handling methods in the NSSFC forecast environment. These have been documented in the report, Functional and Performance Requirements of the Next NOAA-Kansas City Computer System.

INTRODUCTION

The Centralized Storm Information System (CSIS) is an experimental interactive computer system at the NOAA operational complex in Kansas City. This complex consists of the NWS National Severe Storms Forecast Center and a NESDIS Satellite Field Services Station (SFSS), and will be denoted as NSSFC in this document.

CSIS is the first major interactive system available to the operational forecaster. The primary objective of the CSIS demonstration is to evaluate and establish the utility of an interactive computer system to the severe storm forecaster. A second objective is to establish the functional and performance requirements of an operational NSSFC

interactive system. A third objective is to establish and evaluate the interface requirements between an interactive computer and the evolving operational systems used by NOAA. The ultimate goal of CSIS and any operational successor is to improve the overall severe storm forecast and watch procedures at NSSFC and the services provided by the Kansas City SFSS.

Specific aspects of CSIS will be evaluated against the objectives outlined in the Test and Evaluation Plan for CSIS (Appendix A). In addition to the Test and Evaluation plan, two previous reports have been prepared, CSIS Test and Evaluation -- Phase I and Phase II. The Phase I report was a pre-CSIS test based upon experience gained on two remote terminals connected to the University of Wisconsin's Man Computer Interactive Data Access System (McIDAS) during the period April 1-July 15, 1981. In February 1982 the stand-alone CSIS was installed at the NSSFC. The Phase II report covered the period from mid-July 1981 through June 1982 and concentrated on the final three months of the period. This report will cover the period from February 1982 when the CSIS system was installed through June 1983.

CSIS HARDWARE

The CSIS hardware consists of a GOES receiving antenna system, three Harris/6 computers, three interactive terminals, FAA "604" teletype input, two autodialers, and an

interface to the NSSFC computer. The autodialers provide access to weather radar data, while the interface to the NSSFC computer provides a direct link to the National Meteorological Center (NMC), the NWS-AFOS system, and the FAA-Weather Message Switching Center (WMSC).

GOES imagery is acquired by a 15 foot antenna on the roof of the Federal Building in Kansas City. The GOES receiving system performs the data reception, demodulation, and synchronization functions necessary to receive digital satellite data in real time. Sectorization is performed in CSIS so that any part of the entire hemisphere can be examined.

The three Harris/6 computers are identical, but each performs different functions. There is one data base manager (DBM) and two application processors (AP). These computers are linked by a high speed (10 mb/sec) line. The DBM handles all incoming data. Its function is to receive, preprocess, and store all of the data which is used by CSIS. The second computer is used as an AP for the operational support of CSIS. This AP is connected to two interactive terminals and performs all of the analysis and display functions requested by the forecasters. The third computer is used as an AP for both forecast and development activities. It drives a single interactive terminal.

The system was designed with enough redundancy for a

fail-soft, degraded operational mode. The input data lines go to all of the computers, but only the computer designated as the DBM listens actively to these lines. Terminals are attached to the APs through a patch panel, so any terminal can be plugged into any computer. The criteria which determine if a computer is a DBM or AP are contained in software on the disk pack. If one of the computer systems fails, the system is reconfigured with the two remaining computers becoming a DBM and single AP. Reconfiguration takes place through switches on the front of the computer.

CSIS has three interactive terminals. Each terminal consists of an alphanumeric CRT, a high resolution color TV monitor, a joystick pair for input/output, a data tablet, an alphanumeric hardcopy printer, terminal electronics, and a terminal enclosure-desk. The data tablet is used for both position dependent inputs and for user defined command sequences. Each terminal can generate and display two different types of TV presentation (frames). Image frames are essentially pictures and are used to display satellite imagery and radar data. Graphics frames are for displaying less intricate (line segment type) figures. Graphics are used for map backgrounds, analyses, and data presentation. The number of images and graphics is controlled by the number of memory boards in the terminal. Presently, each terminal can store a total of 26 image frames and 13 graphic

overlays. Image frames are configured into paired opposites; the contents of one image in a pair can be modified by the other. For example, visual images can be colorized according to the IR temperature. Also, instantaneous switching between opposites is possible. The graphic overlay pictals can have up to seven different colors. These colors are selectable by the meteorologist via the colorizer tables.

OPERATIONAL EVALUATION

CSIS has had a dramatic and positive impact on the operations of the NSSFC. Because of CSIS, "real time" satellite images have replaced radar as the main tool used at NSSFC to assess movement and growth patterns of thunderstorms. The continued evolution of the system to meet the needs of NSSFC has produced a high degree of forecaster acceptance and dependence on CSIS. The weekly CSIS reports from the operational meteorologists (SELS, SIGMET, SFSS) are peppered with accolades such as "invaluable", "tremendous asset" and "extremely helpful". While CSIS is officially designated as an "experimental" system, in reality it has developed into an operational forecast tool which is relied upon. The usage of CSIS has continued to increase throughout its lifetime. During the current evaluation period an average of 69 programs per hour were executed on each applications processor.

While verification statistics for such a short term must be interpreted with caution, the trend since the installation of CSIS is encouraging (Figure 1). The proportion of severe weather watches which were verified reached an all time high in 1982. Only the rough statistics are available for the first half of 1983, however these indicate that watch verification has remained near the record 1982 level.

CSIS's greatest impact upon the NSSFC operations has been the timely and flexible presentation of satellite imagery. Visible and infrared satellite data are available for a window which includes all of the contiguous United States. The satellite data are received in real-time and are automatically, via a scheduler, displayed at five minutes after the image start time. The meteorologist on duty can define up to six animated loops by specifying the center point and magnification of the picture. When it becomes necessary (or desirable) to change these image parameters, it is a trivial task. A single command triggers a macro to build the new loop. Because of this the forecaster can operate in two different modes. CSIS can be used for sub-synoptic scale surveillance over suspect regions and detailed mesoscale observations where a threat exists, or is expected to develop. With multiple loops, the meteorologist can operate in both modes simultaneously.

The capability to dynamically enhance the satellite

imagery is extremely useful. Color enhancement of the infrared imagery is done routinely. The digital data can be manipulated such that selected portions of the atmosphere (such as low clouds or cold cloud tops) can be displayed with the same temperature resolution as the satellite sensor. Standard color enhancement tables have been created for highlighting details in cold cloud tops. The meteorologist can modify the color enhancement breakpoints as the upper air conditions change (either temporally or spatially). This gives flexibility in data usage. In addition, two images can be functionally combined in a variety of ways. For example, the infrared color enhancement can be used to overlay a visible image.

Conventional surface and upper air data can be printed, plotted or contoured. Plotted and analyzed data can be superposed over the satellite imagery. Numerous fields can be obtained, including divergence or advection of any standard parameter. The ability to create derived quantities such as streamlines, equivalent potential temperature and moisture convergence fields is an outstanding feature of the system. Time and level changes of parameters are also available. The addition of the data tablet to CSIS has permitted easy access to most of the conventional data (Figure 2), without the need to remember the command structure.

Thermodynamic analysis (Stuve or Skew-T), vertical wind

shear information and icing potential probabilities can be obtained rapidly. In addition, isentropic and cross sectional analyses are available to the forecasters.

The capability to create unique analyses is very useful. Data fields can be algebraically manipulated and combined. An example of this is a 500 mb lifted parcel temperature excess. This routine is used to produce an hourly index of the stability using surface data and a prognostic 500 mb temperature field. Grids of the upslope flow component of the surface wind field are also obtainable by manipulating gridded wind and elevation data.

A lot of use is made of routines which sort the conventional ("604") data. Pilot reports sorted by intensity are used routinely by the aviation units. The surface observation remarks scanner is also frequently used to identify areas where notable weather is occurring. The access of text by state rather than by catalog number has increased the utility of these data. A voice synthesizer is also used to alert the meteorologists to any severe weather reports which are received.

Another important aspect of CSIS is the ability to locate points on the satellite imagery using various coordinates. Routines to give the towns, the distance and direction to reporting stations and to VORs from the cursor are often used. Similarly, their inverse, giving the actual

location of a town, airport or VOR on a satellite image have become an integral part of the NSSFC operations. The meteorologist can now identify the exact location of cloud features, and locate the clouds associated with weather observations. Cloud features can also be tracked between two satellite images so that velocities can be obtained. Various map backgrounds are also available. County outline boundaries are used extensively by the SFSS. SIGMET uses a set which show the jurisdiction areas of the FAA-air traffic control centers. A map showing all major cities is used by all units.

CSIS is capable of ingesting weather radar data via two autodialers. Radar data can be composited and remapped into a satellite projection. The data can be color enhanced, animated, and superposed on other data sources. These capabilities have not been fully utilized, since the WBRR data are poorly suited to a digital display. Work is underway to ingest digital radar data from a commercial source.

Two other major enhancements to CSIS have yet to be realized. A link to the NSSFC computer is being established. This will allow CSIS to access model output from NMC. In addition, programs to ingest and display data from lightning detection networks are being developed.

CSIS has undergone evolutionary growth since its installation. From February 1982 to June 1983 over two

hundred new programs have been added to the system. In addition, more than four hundred program changes were made to improve system performance. These changes include:

- o improved objective analysis routines
- o satellite data available for the entire contiguous U.S. and immediately adjacent territories
- o more flexibility in creating animated satellite loops
- o additional IR-color enhancements
- o improved decoders to process all available data
- o routines to execute programs from data tablet
- o unified command structure for processing conventional data
- o procedures for ingesting rapid scan satellite data
- o fast graphics routines for saving base maps
- o missing data alarm for conventional data
- o sorting of conventional data by remarks
- o sorting of pilot reports by intensity
- o accurate location of features with respect to various known sets of points (VORs, counties, etc.)
- o development of report logger utilizing SELS directory
- o improved thermodynamic analysis (Stuve, Skew-T)
- o construction of proposed watch areas directly on a satellite image

- o more efficient program for loading satellite images
- o access of conventional observations by state
- o provisions for user definable map boundaries
- o routines to provide hourly stability index
- o routines to ingest and display lightning detection data
- o programs to permit communications with NSSFC computer
- o routing of severe reports to speech synthesizer
- o routine to compute upslope wind component
- o routines to make system more "user friendly"
- o programs to get and process LFM gridded data
- o computation of icing potential probability
- o computation of vertical and horizontal wind shear
- o improved access to pilot reports
- o rapid azimuth and range calculations
- o vertical profile of wet bulb potential temperature to assess convective instability
- o conversion of thermodynamic analysis routines to standard Wobus functions
- o routines for assessing the parameters involved in mesoscale convective complexes
- o capability to modify sounding parameters
- o addition of lifted parcel temperature and potential wet bulb temperature

- o simplified procedures for operating in a degraded mode.

SYSTEM RELIABILITY

Under the ground rules of the CSIS experiment, the computer system is available to the forecasters on a 168 hour a week basis. However, personnel intimately acquainted with the CSIS software are only available 80 hours per week. Further, technician support is limited to a 40 hour week.

Even under these constraints, unintentional computer halts occurred at an average rate of nine per week for each computer. It should also be noted that the ease of "rebooting" the system (time required is about 30 seconds) makes this procedure the first thing done whenever a problem is experienced.

There was one major system failure during this reporting period which brought the whole CSIS system down for approximately 24 hours. On January 6 and 7, 1983, all of the disks failed so that the system could not be rebooted. The system was reinstalled from backup tapes. However, the tapes were incomplete and nearly a week of effort was required to bring the system back to the previous state.

The main lesson learned from this is that tape backup of the system is not totally adequate. An additional disk drive was added to the system in order to perform a disk-to-disk copy.

SYSTEM MONITORING AND CONTROL PROCEDURES

While NSSFC has computer operators on duty 24 hours a day, the CSIS system has the lowest priority on their time of the three computer systems. Even with this low priority, 52 percent of the computer halts are rectified within two minutes; and 83 percent are restarted within ten minutes.

During the fifteen month period, a computer was inoperative for over one hour on 37 occasions. The effect of these failures is minimized because CSIS was designed to be a fail-soft system. If one of the computers becomes disabled, CSIS can be reconfigured into a two computer degraded mode.

SYSTEM PROTECTION

CSIS appears to have adequate protection against programmer errors causing failure. During the fifteen month test period only 39 computer halts were caused by program error. This represents less than 3 percent of the total. Also, the effect of these halts is minimized since software development is restricted to one of the applications computers. The DBM and the second applications processor are unaffected by programmer errors. The capability to test new software on one computer and then migrate the final version to the other computers is quite useful.

There is also adequate protection against inadvertent actions by the meteorologists. No computer halts have occurred as a result of keyins at the terminals.

DATA ACQUISITION

Presently, five basic types of data are available in CSIS. Conventional surface data, rawinsonde data, teletype messages, GOES mode A satellite imagery and WBRR radar data are ingested.

Surface data are obtained via the FAA '604' line. Presently, about 95% of the available data are disseminated on this line. The surface observation decoder has been modified so that all stations are used as well as specials and delayed reports. The hourly data are decoded as they are received, with most observations present by 20 minutes past the hour. This time is competitive with the direct Weather Message Switching Center line which is NSSFC's principal data source.

Rawinsonde data for the United States, Canada and Mexico are also available in a decoded format in a time frame comparable with other NSSFC data sources. An initial problem with the rawinsonde decoder has been rectified so that all available stations are used.

"Teletype message" data includes forecasts, warnings, MDR data and pilot reports. The timeliness of this data varies from type to type. While the pilot reports are current, MDR data are often more than an hour and a half old before it is available on CSIS. Other sources of these data should be explored. The pilot reports are extremely valu-

able to the NSSFC aviation programs. Routines have been created to periodically list all urgent pilot reports.

Mode A GOES imagery is available from one satellite via a roof-top antenna. This data is available in real-time, approximately 30 minutes sooner than was previously possible. Some modifications to the system are necessary to allow VAS (mode AA) ingestion since after 1985 only mode AA data are scheduled to be collected. A need also exists for a second antenna. Presently, only GOES-EAST data are received. For storms along the Pacific coast, GOES-WEST is almost a necessity.

The radar data are presently ingested through automatic telephone dialers from WBRR attachments at NWS sites. While this has shown the feasibility of getting remote radar data into CSIS, the quality of the WBRR system makes meaningful analysis virtually impossible. A change to the Kavoris system is anticipated later this year.

The Bureau of Land Management operates a lightning detection network across the intermountain region of the western United States. Work has begun to allow CSIS to ingest and display these data.

Work is also underway to allow CSIS to access products from NMC via the NSSFC computer system. This will allow CSIS to acquire model output data and automatically recorded and transmitted aircraft data. This is expected to be a

significant enhancement to CSIS capabilities.

DATA STORAGE AND RETRIEVAL

This is perhaps the nub of an operational meteorological computer system. Without readily accessible current data, no computer - no matter its size or speed - will aid the forecast problem. The CSIS storage and retrieval techniques for data received from the '604' line are quite impressive. Programs to sort these data proceed rapidly with little impact on the system. Redundancy exists so that data is not lost when a computer fails.

Satellite imagery is stored only on the DBM in order to minimize the impact (both in disk space and time) on the system. Thus, when the DBM is inoperative all imagery is lost. This is a minor problem because the system can be re-configured if the DBM fails. All three computers are capable of ingesting satellite data. The amount of data lost averages less than one pair of images (visible-infrared) per day.

However, the time taken by satellite image display is significant. It takes approximately 30 seconds to display an individual image. When this is going on, other processes proceed at a significantly slower rate. A more efficient image display routine has been developed which permits more interactive usage during the display process. While this routine has helped ease the display problems, the image

loading process continues to be a major load on the system.

This is a direct indication of the limitations of computer power in CSIS. A Harris/6 type computer can drive only one video system and remain interactive. Experience with CSIS has shown conclusively that the processing capabilities are undersized. The impact of this is aggravated by the fact that meteorological data are collected and transmitted in "bursts", with myriad data transmitted simultaneously. This in turn causes the meteorologist to also work in a burst mode, looking at data as soon as it is available.

When 15 minute satellite information is being ingested, the problem obviously magnifies. Three minute satellite data can be collected, however a staff member must be dedicated to oversee the operation. Real time display and utilization of three minute data is nearly impossible.

As the number of image frames on CSIS increases, along with the additional impact of radar imagery, this problem will become more significant.

Radar data ingest and processing has a high overhead. The process to remap the data to a satellite projection effectively takes an entire computer for three to five minutes. The WBRR data have not shown enough information content to merit the expense. Significant improvement in data quality is expected from the Kavoris system which is scheduled to be installed later this year.

FORECASTER-MACHINE INTERFACE

Data tablets were installed on all the terminals in September 1982. The tablet configuration is user definable with up to 25 different configurations saved in the system. Programs on the tablet are activated by a pressure pen. A command matrix for conventional surface and upper air data has been developed for one section of the tablet (Figure 2). The matrix allows many of the learning advantages of traditional menus without the sequential constraints and inherent limitations of menus. For example, to display the current analysis of surface temperature advection overlaid on a satellite image the forecaster would use the pen to touch "CONTOUR", "T", "param ADV", "NOW", "SFC", "SAT", "GO". To view the same parameter from the past hour would then require touching only "-1 HR", "GO". Time and level changes of parameters are also available. The tablet interface has allowed users to access a wide variety of products without much knowledge of the system. The tablet interface needs to be expanded to include access to additional products.

Strings of programs (macros) are used extensively on CSIS. These macros permit multiple keyins to be executed by a single command. For example, the upper air analysis package can be displayed via a single keyin. Macros have also been implemented for conventional data plotting and analysis. This has resulted in a more unified and logical

command structure.

A system help function has been added to the system for refreshing the meteorologist's memory of how any particular command should be entered. Any keyin on the system can be entered along with a "?" to obtain an explanation of the necessary input.

USER TRAINING

The evolutionary nature of the software has made extensive formal training impractical. Rather, training of meteorological users has been done by a hands on approach. Such OJT is very effective. No matter how trained, users will remember only the commands they need and use. The addition of more system help functions and the data tablet command mode has alleviated the need to remember lengthy command formats.

Operator training has been adequate. Significant improvements were made to the operator's manual, the most notable being a chapter on problems/solutions. This has proven to be a valuable aid in handling most of the problems which occur.

USER DOCUMENTATION

The CSIS user's manual is essentially a dictionary covering the 182 programs which are available. The manual is functionally oriented (giving instructions for use) rather than documentary (describing how operations are

performed). It is useful for informing users how to execute elements from a large software library. While improvements in the manual have been made, the need still exists for a general guide on how to use CSIS.

EXTERNAL SYSTEM INTERFACES

The interfacing of CSIS to the NSSFC Eclipse computer, which in turn is interfaced to both AFOS and NMC, is in the testing stage. One fact that has become apparent is that the use of different principal data sources for the two NSSFC computer systems is desirable. When one source fails the other can be used to get data to the forecaster.

WORK ENVIRONMENT

Ergonomic factors have been a major concern in the implementation of CSIS in an operational environment. Our experience has been that the forecasters tend to "pass through" the work station without spending prolonged periods glued to the screen. Because of this, the physical discomfort from using standard office furniture did not arise. The special "bio-chairs" which were purchased with CSIS were not robust enough and broke.

The modular design of the work stations has proven desirable. The various components of the terminal can be positioned according to the needs of the work situation. However, the electronics for the CSIS terminals are located in the storage area of the desks used to support the

screens. This arrangement puts the cooling fans in the midst of the forecast area. Their drone is very distracting, and tends to induce drowsiness during the early morning hours. In addition, the electronics can be affected when chairs bump into the cabinet inadvertently.

Drawing map backgrounds and contours with two pictal thick lines has eased the "30 Hz flicker" problem.

SYSTEM EXPANSION

Software can be written, tested on one of the processors, and then transferred to the other two fairly simply. This competence now exists at NSSFC. Since February 1982, over two hundred new programs and 400 program modifications have been implemented. This is an indication of the evolutionary nature of CSIS. Requests, ideas, complaints, etc., of CSIS were collected and prioritized into a "wish list" which was passed to the Space Science and Engineering Center (SSEC). The system was then added to or modified according to the needs of the forecasters. In order to minimize adverse impacts on the operational system, many changes were first developed on the McIDAS at SSEC and then installed on the development computer of CSIS. The dramatic acceptance of the system by the forecasters is a result of their involvement in the changes made to CSIS.

Several hardware additions to CSIS have been made. Data tablets have been added to each of the three applications

terminals. The tablets have virtually replaced the keyboard for accessing conventional weather data and analyses. A speech synthesizer has also been added. This is used primarily to alert the meteorologist to incoming reports of severe weather. An additional 300 mb disk drive has been added to CSIS. This drive is used to copy operational disk packs and decrease the problems which are involved in backing up all the necessary programs and files on magnetic tape. It has also served as a backup disk drive which has been used when disk problems occur on the DBM. In addition, a hard copy device has been added which permits copies to be made from any terminal.

EASE OF REPAIR

The accessibility of spare parts allows "troubleshooting by substitution" and allows us to maintain the system. Local repair capabilities have been greatly enhanced by the completion of on-site electronic technician training and additional diagnostic routines. There will always be the unavoidable problem of testing some of the equipment "on-line", but it can be kept at a minimum. A peripheral equipment repair plan has been prepared. This plan appears satisfactory, except for the antenna hardware group which lacks spare parts.

HARDWARE DOCUMENTATION

Many of the initial shortcomings in hardware documenta-

tion have been solved. There is now a comprehensive overall drawing of the terminals which shows all the interconnecting cables and the data flow paths. While this is not available for the Harris/6 and SSEC equipment, drawings of the individual subsystems are available. Some additional documentation has been obtained from the VISSR Interactive Registration and Gridding System (VIRGS) Terminal Group. While this information is not totally current, it gives functional descriptions and circuit analyses for the system.

SOFTWARE DOCUMENTATION

NSSFC has obtained documentation on the various file structures which are used in CSIS. Documentation has also been provided for most of the system subroutines. In addition a source management system has been implemented and comprehensive listings of all current source codes for CSIS are maintained.

The documentation is adequate for a programmer to gain the expertise needed to modify programs and to create original programs. During the fifteen month evaluation period, 57 new programs or macros were developed by NSSFC.

PRESENTATION AND DISPLAY

The presentation and display capabilities are one of the outstanding features of CSIS. The color enhancements which are available for the imagery have proven invaluable. Standard enhancement tables have been developed for dis-

playing the infrared satellite images. These allow the meteorologist to manipulate the enhancement breakpoints relative to the tropopause or equilibrium temperature. Additional enhancements have been developed for the cold season, when relatively warm low clouds have a significant impact upon the aviation forecast program and the SFSS guidance. One problem with the image display capabilities is that only 64 gray shades (6 bit) are available for display, while the infrared data has a range of 256 values (8 bit). Software capabilities allow CSIS to display full resolution data over selected portions of the infrared temperature spectrum, however, some resolution must be sacrificed outside of that range. For instance, maximum display resolution is often used to enhance cold cloud tops, with a loss of detail in the warmer temperature regions. Experience has shown the desirability of having some eight bit display capability available.

The CSIS video terminals currently have 26 "image" frames and 13 "graphic" frames available. The image frames are typically blocked off into four animated loops. The animation capabilities of CSIS allow the meteorologist to easily monitor the development and movement of weather systems. The use of "opposite" frames permits easy switching between the visible and infrared loops. Also, the contents of two image frames can be combined, such that the

infrared enhancement can be used to tint the visible image. The capability to interlace the contents of three image frames is desirable. This would allow visible, infrared and radar imagery to be presented as one unified data set. This capability would also be valuable for the display of VAS imagery.

It has become apparent that more than 26 frames are needed for displaying images. This problem will become more acute when greater utilization is made of radar data. A minimum of 12 additional image frames are needed on each CSIS terminal. Under the CSIS construct architecture a 12 image frame increase would also give a 6 graphic frame increase. The additional graphics frames are needed to display Numerical Weather Prediction (NWP) products from NMC and lightning network data. The additional graphics will permit animation of NWP fields.

The CSIS graphic frames are 3 bit frames which allow 7 colors. Several analyses can be overlaid using different colors, but experience has shown that the forecasters seldom use more than 3 graphic overlays for a single display. The current graphics are not individually erasable, whenever a graphic frame is erased, all fields are erased. A system which had the graphics one bit deep (with individual coloring capabilities) and individually erasable is desirable.

The animation system has been modified so that the loop pauses on the latest image. Also the ability to loop forward and backward has been added. These animation features can be used both with image and graphic frames.

Initial problems with the labelling of analyses have been resolved. Both time and level changes of a parameter are now properly identified. Seven graphics colors can be selected, and variable length dashed lines are available.

Work has begun on an interactive reanalysis routine. This will allow the meteorologist to interact with the computer by reanalyzing portions of the contours. The change made to an analysis would also be reflected in the gridded data, such that further operations could be performed with the new analysis.

A Honeywell VGR 4000 black and white hard copy device has been added to CSIS. The device can be switched to obtain copies from any of the CSIS terminals. The copier has been used extensively for saving both images and graphics.

DATA QUALITY CONTROL

There is no automatic quality control of conventional ("604") data before archiving. This is by design since the meteorologist needs to be aware of any changes to the data. For similar reasons there is no screening for bad data when a plot is selected. A "buddy check" routine written by

NSSFC is used before data analysis. This has proven to be an adequate error capturing routine, and has eliminated the problem of "bulls-eyes" in the analyses.

A program has been added to CSIS to alert all terminals when conventional data over the 604 line is not being received. It has been decided that a similar alert for missing satellite ingestions is not needed since the loading of a blank image makes the problem apparent.

DATA ANALYSIS

One of the greatest improvements to McIDAS made in CSIS is the quality of the analysis algorithms. The implementation of the data tablet and "macros" has allowed easy access to nearly all of the analysis routines. However, there is still a need to perform a surface analysis over the entire U.S. region with 0.5 degree grid spacing. This would permit detailed analyses over the entire U.S. to be scheduled, and would eliminate the problem of getting a different analysis when using different grid spacing. It would also speed up the display of the analyses since the data would be pre-gridded. Software to perform this analysis was tested during this reporting period. It was concluded that the program size and running time for these routines caused the potential for locking out other programs which are required for routine ingestion and dissemination of data.

Work to allow a manual reanalysis capability is

underway. Human modification of the machine analysis is seen as an integral step in making CSIS truly forecaster interactive.

Thermodynamic analysis backgrounds have been improved, including options to plot Stuve or Skew-T analysis. In addition, programs to compute the icing potential, vertical wind shear, and vertical profile of potential wet bulb temperature have been added to CSIS.

The thermodynamic analysis procedures used on CSIS for computing quantities such as lifting condensation level, pseudo-wet bulb potential temperature and lifted parcel temperature have been converted to use standard NSSFC (Wobus) algorithms.

DERIVATIVE QUANTITIES

The capability to create derived quantities from conventional data remains a strong feature of CSIS. Access to derived quantities has been added to the data tablet so that divergence or advection of any parameter can be easily computed. Moisture convergence and temperature advection fields are among the most frequently utilized derived parameters. Also, the capability to perform both time changes and level changes of parameters is invaluable.

The ability to manipulate gridded data fields also permits "non-conventional" derived products to be created. An example of this is the hourly computation of the lifted

index field, via subtraction of surface lifted parcel temperature data from the 500 mb temperature analysis. Also, the upslope flow component of the surface wind field can be computed by combining gridded wind and elevation data.

Quantities such as cloud growth rates derived from satellite data are also available to the meteorologist. While this information is presently used subjectively, work is currently being directed towards the objective documentation of its relationship to severe weather.

FORMAT TRANSFORMATIONS

The philosophy of transforming coordinates of data to that of the densest data set concurrently displayed has proven quite reasonable. The distorting of satellite imagery to a Mercator projection can lead to fallacious conclusions. This completely obviates the need for this type of transformation.

Conventional data and analysis are nearly always displayed in the satellite projection. The transformation process appears to be very efficient, with no detectable delay required for the coordinate change.

The coordinate transformation required to remap radar data into a satellite projection has a high overhead. The process requires approximately three minutes of computer time to remap a single radar image. The resources required will obviously limit the amount of radar data which is

remapped.

INTEGRATION OF ANALYSES

The ability to superpose data and analysis on the satellite imagery helps the forecaster integrate the various data sets which are available. Also, the ability to construct severe weather watches directly on the satellite loops allows the forecaster to monitor the intensity and movement of thunderstorms relative to the watch area. Various features in the satellite imagery can also be located with reference to the surface reporting network. These capabilities have been extremely helpful.

Experience with superposed graphics has shown that even with color only two fields (and a map background) can be intelligently interpreted. An easily used fade capability for graphics would aid in the interpretation of multiparameter charts. Also, individually erasable graphic fields are desirable.

Kavoris type radar data has not yet been available on CSIS. This data is expected to be a significant enhancement to the system, by allowing direct comparison of satellite, radar and conventional data.

LOCAL PRODUCT PREPARATION

CSIS is not used for direct generation of forecast products for public dissemination. These are done on the other computer systems at NSSFC. However, CSIS is used to

produce information that is directly inserted into publicly disseminated products. When severe weather watches are constructed directly on satellite images, the geographic information needed in the watch message is returned. In addition, a routine exists to generate the information needed to plot severe weather reports on the SELS "activity chart".

Because of CSIS, "real-time" satellite images have replaced radar as the main tool depended upon at NSSFC to assess growth patterns of thunderstorms. CSIS has the capability to locate cities, counties and VORs which aids in many aspects of forecast product preparation.

SIMPLE MODELS

Position extrapolations via trajectories constructed assuming a steady state wind field are used extensively in NSSFC operations. An hourly lifted index chart is produced by advecting the 500 mb temperature field and lifting the latest observed temperature, dewpoint and pressure fields.

The advection model is also used to extrapolate meso-scale convective complexes. The timeliness of the model is excellent and its quality is very surprising. The ability to create vertically averaged, density weighted wind fields has also proved useful for computing the wind field to be used by the advection scheme.

DEVELOPMENT OF OPERATIONAL PROCEDURES

McIDAS was developed as a research tool and much of the work done at NSSFC has been to adapt it to an operational environment. The primary objective was to permit simple routine operation of the system while maintaining flexibility. Numerous programs and macros have been developed at NSSFC to streamline the operational procedures, including:

- o a routine to schedule the satellite data ingests
- o routines to automatically load satellite loops at each terminal
- o procedure for rebuilding or repositioning a loop
- o development of standard IR color enhancements
- o routine to plot position of surface observing stations
- o routines to locate severe reports on the satellite imagery
- o procedure to relate features in the imagery to the nearest surface observation
- o routines to control the access of satellite loops
- o macro for plotting or printing conventional data
- o macro for analysis of conventional data
- o macro for display of soundings
- o procedures for generation and display of upper air data and extrapolations
- o procedures for generation and display of isentropic

analyses

- o macro for display of vertical cross sections
- o development of software for use with data tablet
- o operational procedures for satellite ingests during RISOP and RRSO
- o scheduled generation of hourly lifted index field
- o computation of upslope flow component of surface wind field
- o "buddy-check" procedure to screen for bad data prior to analysis
- o addition of convective sigmet coastal water boundaries
- o procedure for saving a map outline for each satellite loop
- o procedures for displaying the profile of vertical wind shear
- o procedures for displaying the vertical profile of the wet bulb potential temperature
- o procedure for labelling of time or level change analyses
- o conversion of thermodynamic routines to Wobus functions.

In addition, operational procedures have been developed for saving conventional data, system files and system programs on tape. All source code for CSIS is also rou-

tinely backed up on tape. Procedures for operating the system in a degraded mode have also been improved.

SUMMARY

The most significant operational features of the system include:

- o timely and flexible presentation of satellite imagery
- o color enhancement of satellite imagery
- o access to conventional surface and upper air data
- o ability to superpose data and analyses on satellite imagery
- o capability to schedule commands for execution
- o ability to create derived quantities (divergence or advection of a parameter, time and level changes)
- o capability of creating unique analyses via manipulation of gridded data
- o location of points on the satellite imagery using various coordinates
- o macro language facility for defining a sequence of commands
- o availability of simple models
- o modular work stations
- o color graphics.

Several significant enhancements to CSIS have yet to be evaluated, including:

- o ingest of Kavoris type radar data
- o link to NSSFC computer system
- o ingest of lightning strike data.

The capabilities found to be needed in an operational interactive computer system over and above those of CSIS include:

- o increased processing capabilities to allow greater interactive usage
- o additional image and graphic frames
- o 8 bit display capability for image frames
- o individually erasable graphics
- o capability to perform 0.5 degree grid analyses for entire U.S.

CSIS represents a major step toward providing the operational meteorologist a truly interactive, information handling and display system. It has had a dramatic and positive impact on the operations of the NSSFC. While verification statistics for such a short term must be interpreted with caution, these indicate that the proportion of severe weather watches which were verified reached an all time high in 1982. Watch verification for 1983 has remained near the record 1982 level.

The CSIS experiment was the driving factor in determining the potential for "high-tech" data handling methods in the NSSFC forecast environment. These are documented in

the report, Functional and Performance Requirements of the Next NOAA-Kansas City Computer System.

The evolutionary "bottom up" design philosophy of CSIS has resulted in many changes to the system and a dramatic acceptance of the system by the forecasters. Since CSIS was an experiment, no one was forced to use it. All of the preexisting NSSFC capabilities were left intact during the CSIS experiment, and forecasters could use anything they wanted. As the system evolved during the first year, more forecasters came to use and depend on it. Having a system which can evolve in response to the individual forecaster's needs and desires has resulted in improved system efficiency and acceptability.

SEVERE WEATHER WATCH VERIFICATION

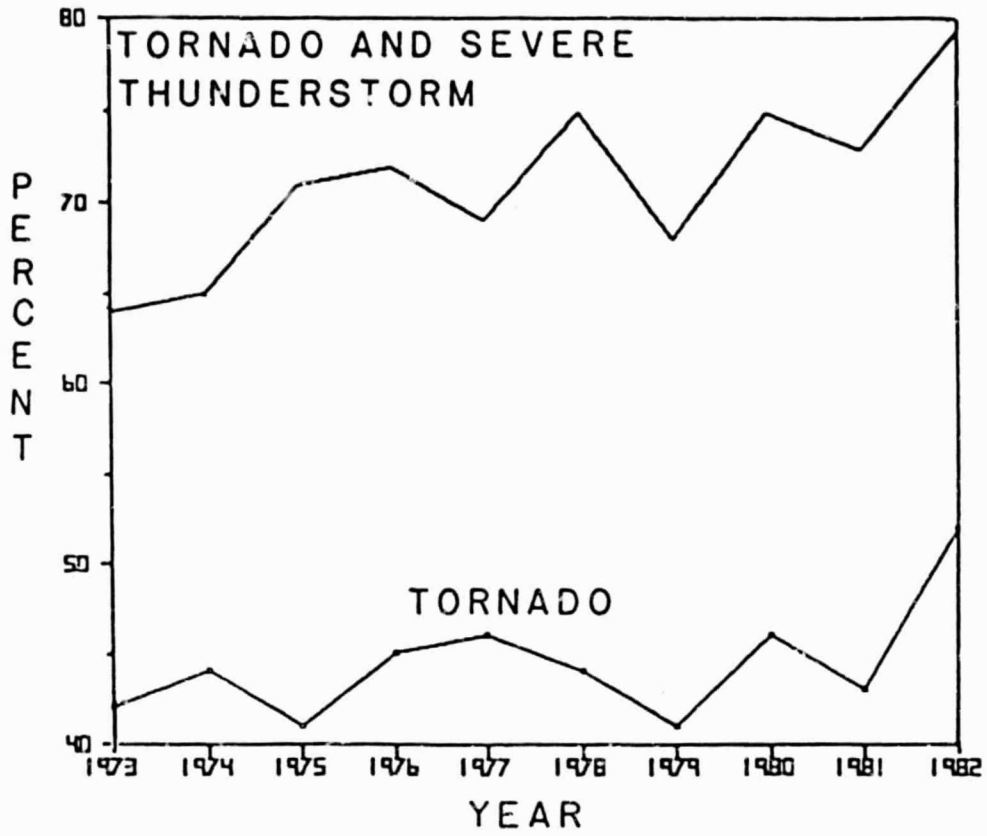

Figure 1. Percent of severe weather watches verified.

| oper | param | | time | levl | map | |
|------------------|---------------|------------|-----------------|------------------|--------------|---------------|
| PLOT | T | THE | NOW | SFC | SAT | |
| | TD | Q | -1 HR | 850 | MERCATOR USA | |
| CONTOUR | PRE | Z | -2 HR | 700 | MERCATOR CTR | |
| | WIN | STR | -3 HR | 500 | color DFLT | interval DFLT |
| PRINT | PLT | SPD | -6 HR | 400 | 2 | 1 |
| | DIV | T.IW | -12 HR | 250 | 3 | 2 |
| CLEAR UP PROBLFM | WX | LCL | -24 HR | 200 | 4 | 4 |
| | LPT | VOR | -48 HR | TRO | 5 | 5 |
| ERASE | SAVE MYP_____ | ABV | set time change | set level change | 6 | 10 |
| | param: DIV | param: ADV | change off | change off | 7 | 20 |
| Go | | | | | dash on | 50 |
| | | | | | | 100 |

Figure 2. Data tablet command matrix for conventional data.

N85-28510

D4

FUNCTIONAL AND PERFORMANCE REQUIREMENTS OF THE NEXT
NOAA-KANSAS CITY COMPUTER SYSTEM

Frederick R. Mosher
National Severe Storms Forecast Center
Kansas City, Missouri

46
October 1984

NATIONAL CENTER UPGRADE PROGRAM
TABLE OF CONTENTS

| | <u>Page No.</u> |
|----------------------------------------------------------------------------------------|-----------------|
| I. Introduction | 1 |
| II. Basic Organizational Responsibilities | 1 |
| A. Mission | 1 |
| B. Operational Units | 1 |
| 1. The Severe Local Storms Forecast Unit (SELS) | 2 |
| 2. National Aviation Weather Advisory Unit (NAWAU) Convective SIGMET Section | 2 |
| 3. National Aviation Weather Advisory Unit (NAWAU) In-Flight and Area Forecast Section | 2 |
| 4. National Public Service Unit (NPSU) | 3 |
| 5. Satellite Field Services Station (SFSS) | 3 |
| C. Support and R&D Tasks | 4 |
| 1. Techniques Development Unit (TDU) | 4 |
| 2. Electronic Data Processing Unit (EDP) | 4 |
| 3. AFOS Gateway Backup | 4 |
| 4. Central Region Headquarters (CRH) Scientific Services Division (SSD) | 5 |
| 5. Maintenance and Administrative Support | 5 |
| III. Current Computer Capabilities | 5 |
| A. Data General Eclipse S/230 | 5 |
| B. AFOS | 6 |
| C. EAS | 7 |

| | | |
|-----|------------------------------------------------|----|
| D. | CSIS | 8 |
| E. | Radar Receivers | 9 |
| IV. | Scope of System Upgrade | 10 |
| A. | Time Frame | 10 |
| B. | Extent of System Upgrade | 10 |
| C. | Anticipated Future Expansion | 10 |
| 1. | Organizational Changes | 11 |
| 2. | VAS | 11 |
| 3. | NEXRAD | 12 |
| 4. | GOES-NEXT | 12 |
| 5. | Profiler | 13 |
| 6. | Lightning | 13 |
| 7. | Automated Surface Observing System | 14 |
| 8. | AWIPS-90 | 14 |
| 9. | ARF | 14 |
| V. | Requirements | 15 |
| A. | Input Data | 15 |
| 1. | Surface Data | 15 |
| 2. | Satellite Imagery | 17 |
| 3. | Radar Data | 20 |
| 4. | Pilot Reports | 22 |
| 5. | Plain Language Messages and Coded Forecasts | 23 |
| 6. | Upper Air Observations | 24 |
| 7. | Centralized Charts | 25 |
| 8. | NMC Fields | 25 |
| 9. | Lightning | 26 |

| | | |
|-----|---------------------------------------------|----|
| 10. | Data Collection Platforms | 26 |
| 11. | Input Data Summary | 27 |
| B. | Output Data - Forecasts | 27 |
| 1. | Forecast Text Preparation | 27 |
| 2. | Forecast Preparation Using Graphical Inputs | 28 |
| C. | Data Processing | 29 |
| 1. | Sizing of Processing Development | 29 |
| 2. | Data Ingestors | 30 |
| 3. | Decoders | 30 |
| 4. | Quality Control of Incoming Data | 31 |
| 5. | Plotting and Listing of Observations | 32 |
| 6. | Analysis of Data | 33 |
| 7. | Geographic Data | 36 |
| 8. | Satellite Data Processing | 37 |
| 9. | Radar Data Processing | 40 |
| 10. | Aviation Data Processing | 40 |
| 11. | Numeric Guidance Processing | 41 |
| 12. | Verification Processing | 41 |
| 13. | Lightning | 42 |
| D. | Workstation Requirements | 42 |
| 1. | Workstation Functions | 42 |
| 2. | Workstation Command and Control Module | 43 |
| 3. | Alphanumeric Display Module | 44 |
| 4. | High Resolution Graphic Display Module | 45 |
| 5. | Image Display Device | 46 |

| | | |
|------|-----------------------------------------|----|
| 6. | Extended Looping Display | 47 |
| 7. | Map Plots | 48 |
| 8. | Printers | 48 |
| 9. | Image and Graphic Copies | 49 |
| 10. | Ergonomic Requirements | 49 |
| E. | System Utilization | 50 |
| 1. | Conventional Data Utilization | 50 |
| 2. | Satellite Data Utilization | 52 |
| 3. | Radar Data Utilization | 53 |
| 4. | Forecast Data Utilization | 53 |
| 5. | Diagnostic Model Utilization | 54 |
| 6. | Forecast Product Preparation | 54 |
| 7. | Research and Development Utilization | 54 |
| VI. | System Support | 55 |
| A. | Software Development Aids | 55 |
| 1. | Programming | 55 |
| 2. | Higher Order Command Procedures | 55 |
| 3. | Interactive Editors | 56 |
| 4. | Utilities | 56 |
| 5. | Processing on Remote Computers | 56 |
| 6. | Software Documentation | 56 |
| B. | Hardware Maintenance | 57 |
| C. | Training | 58 |
| VII. | System Reliability | 58 |

I. INTRODUCTION

The development of the Advanced Weather Interactive Processing System for the 1990's (AWIPS-90) will result in more timely and accurate forecasts with improved cost effectiveness. As part of the AWIPS-90 initiative, the National Meteorological Center (NMC), the National Severe Storms Forecast Center (NSSFC), and the National Hurricane Center (NHC) are to receive upgrades of interactive processing systems. This National Center Upgrade program will support the specialized inter-center communications, data acquisition, and processing needs of these centers.

In the preparation of this initiative, a document called "The Functional and Performance Requirements of the Next NOAA-Kansas City Computer System" by Schaefer et al (1983) was prepared. This document outlined the missions, current capabilities and general functional requirements for the upgrade to the NSSFC. The ground rules for preparing this document were to state the requirements without any regard for system costs. In view of limited resources being made available for the National Centers Upgrade, a validated requirements document is needed. An attempt will be made to validate and prioritize the requirements.

A sense of current system capabilities and performance will be given along with the requirements for the upgraded system.

II. BASIC ORGANIZATIONAL RESPONSIBILITIES

II.A. MISSION

The National Severe Storms Forecast Center (NSSFC) in Kansas City, Missouri is the office responsible for forecasting severe thunderstorms and tornadoes throughout the contiguous United States. In addition to severe weather forecasting, NSSFC responsibilities include a variety of national and regional functions. The 85 meteorologists, meteorological technicians and support staff at NSSFC work round-the-clock and prepare national weather summaries, aviation forecasts and advisories to aircraft in flight.

II.B. OPERATIONAL UNITS

In order to fulfill its mission, the center is divided into semi-autonomous units, each with unique responsibilities and distinctive requirements. The operational units are:

II.B.1. The Severe Local Storms Forecast Unit (SELS)

The Severe Local Storms Forecast Unit has the responsibility for the issuance of severe thunderstorm and tornado watches for the contiguous 48 states. This unit maintains a continuous watch for thunderstorm activity and issues outlooks for general and severe thunderstorms for a 24-hour, 21-hour and 16-hour period ending at 6AM CST the next day. These outlooks are disseminated in both alphanumeric and graphic forms. SELS also issues, as required, from one to six hours in advance, severe thunderstorm and tornado watches for specific areas and time periods. Watches are issued for those areas where thunderstorms are forecast to produce one or more of the following:

1. Hailstones of 3/4 inch diameter or larger
2. Surface wind gusts of 50 knots or greater
3. Tornadoes.

II.B.2. National Aviation Weather Advisory Unit (NAWAU) Convective SIGMET Section

This section issues bulletins to aviation interests for in-flight hazardous weather phenomena of a convective nature (e.g., thunderstorms, tornadoes) for anywhere in the contiguous 48 states. These bulletins are issued hourly and describe the location, intensity, movement and trend of convective storms. This unit also routinely plots hourly radar reports from more than 100 sites in the U.S. and Canada, keeping the SELS forecaster briefed on significant storm development as depicted by radar.

II.B.3. National Aviation Weather Advisory Unit (NAWAU) In-Flight and Area Forecast Section

This section issues aviation forecasts for the 48 conterminous states based on guidance products prepared by NMC as well as terminal and route forecasts prepared by the various WSFOs. These forecasts are issued three times daily for periods up to 18 hours and include ceiling, visibility, precipitation, surface winds, icing and freezing level, turbulence and other weather elements of concern to aviation. The section also issues, as warranted, in-flight advisories on potentially hazardous flying weather for broadcast through FAA facilities to aircraft in-flight and directly to FAA and NWS personnel.

II.B.4. National Public Service Unit (NPSU)

This unit prepares weather information of a national interest. Its products include the National Weather Summary issued four times daily, the Selected Cities Weather Summary and the Travelers Forecasts, both issued twice daily. In times when a hurricane has entered the United States, a special National Storm Summary is produced every 6 hours to describe the storm's progress and the various weather watches and warnings that have been issued by Weather Service field offices. This unit also prepares special forecast summaries for national holidays. National dissemination of all products is achieved through an AFOS link-up with the National Meteorological Computer System which in turn distributes to users through Service C and NOAA Weather Wire Systems.

II.B.5. Satellite Field Services Station (SFSS)

The SFSS routinely receives and processes cloud photographs from the GOES spacecraft. These photos are displayed and interpreted for local use at the NSSFC. The SFSS also relays the satellite data over facsimile circuits to NWS Forecast Offices (WSFOs) in 23 cities within the Central and Southern Regions of the NWS, as well as other government agencies and some private and commercial organizations.

In addition to providing support to the NSSFC, a primary responsibility of the SFSS is to provide interpretative services to the WSFOs. In this capacity, the SFSS meteorologists act as consultants and directly contribute to the decision making process required to produce or amend forecasts and warnings. This is accomplished by direct telephone contact and Satellite Interpretation Messages (SIM), which are prepared and disseminated every six hours. The messages are based on satellite imagery and include information on all significant weather systems in the central portion of the U.S.

Recently the SFSS meteorologists began issuing Meso Update SIMs. This product, based on extensive mesoscale meteorological experience and state-of-the-art technology, is designed to provide the field forecaster a detailed interpretation of what will happen in the next 1-3 hours concerning significant features. Phenomena such as rapidly developing thunderstorms, merging cells, intersecting boundaries, and heavy snow are highlighted.

The SFSS has assumed the responsibility of evaluating the utility of remotely sensed atmospheric soundings from

the GOES East VAS (VISSR Atmospheric Sounder). Working closely with NSSFC forecasters, the SFSS is evaluating VAS data as it applies to NSSFC's products in order to determine the value of acquiring high resolution soundings.

II.C. SUPPORT AND R&D TASKS

Support and R&D tasks at the center which require computer support are pursued by:

II.C.1. Techniques Development Unit (TDU)

The Techniques Development Unit of NSSFC is pursuing a program of organized research aimed at general improvement of decision-making procedures in severe storm prediction, the analysis of prediction errors, and the identification of weather conditions leading to warning requirements. The research team has as its main task the introduction of science, advanced technology, and the systematic study of severe storm forecasting. The unit serves as an interface transferring advances in mesoscale meteorology to the operational forecasters. The unit is skilled in the application of digital computers and modern interactive technology, in developing diagnostic programs and procedures, and in the analysis of errors in numerical prediction models. TDU continually interfaces with forecasters to understand the problems faced, to present them with new procedures for resolving these problems, and to sympathetically seek and receive the forecaster's reaction to the application of these procedures. The TDU also conducts the NWS convective watch/warning verification program. The verification activities may be expanded in coming years to include other types of watch/warnings.

II.C.2. Electronic Data Processing Unit (EDP)

The Electronic Data Processing Unit operates an AFOS-type Data General Eclipse computer system which is linked to the NSSFC AFOS computer and to NMC's IBM 360/195's. This computer system is used to process the voluminous amount of data received here at the National Severe Storms Forecast Center. It does much of the select-sorting, and calculations required to support the needs of the Center's various operational programs. The computer is also used extensively for research and the investigation of severe local storms and other weather phenomena.

II.C.3. AFOS Gateway Backup

Backup to the AFOS is supplied by the NSSFC computer system. When the NWS-Weather Monitoring Control Center's Gateway is not functioning, the NSSFC computer relays selected products from the FAA's communication system to AFOS and from AFOS to the FAA's communications system.

II.C.4. Central Region Headquarters (CRH) - Scientific Services Division (SSD)

The NSSFC computer system is used by the colocated CRH/SSD in the development of new AFOS products. The development and evaluation of new application programs are done on the NSSFC computer before they are released to the field. The NSSFC frequently makes use of these new products after preliminary evaluation has been completed by the SSD.

II.C.5. Maintenance and Administrative Support

The NSSFC has a staff of computer operators and electronic technicians tasked with the operations and maintenance of the NSSFC computer systems. In addition, there is currently technical word processing done on the system, center accounting, and inventory control programs run in support of administration activities.

III. CURRENT COMPUTER CAPABILITIES

III.A. DATA GENERAL ECLIPSE S/230

The Eclipse S/230 16-bit computer forms the backbone of the NSSFC computational capabilities. As presently configured (Fig. 1) this computer has 1,024,000 bytes of memory and has auxiliary storage on several disks including two 300 MB disks, diskettes and tape drives. Currently there are 36 terminals and communication lines active on the computer. It is noted that the present system serves as a word processor to the secretaries of TDU, SFSS and CRH-Data Acquisition Division (DATAC). This function is not anticipated for the future system. The requirements and usage of secretarial word processing is such that independent systems are more cost effective (ref: Feasibility Study for Purchase of Word Processing Equipment at the National Severe Storms Forecast Center, 1982) and thus should be used.

The Eclipse is interfaced to the NOAA computers in Suitland, the AFOS systems, the FAA-Weather Message Switching Center (WMSC) computers and CSIS. The Suitland link is via a remote job entry emulator with a 9600 baud line. Effectively, the Eclipse serves as a card reader, line printer to the IBM 360/195 system. Through this link

large, computationally involved algorithms are executed in both operational and research modes. This link is also used to create data files on the NOAA computers for inclusion in NMC products. NSSFC products output to NMC over this link include severe storm and tornado watch box coordinates and the daily severe storm activity summary. NMC products input to NSSFC over this line include LFM forecast products not available over AFOS, a hourly bandpass analysis, and a back-up access to the WMSC surface and upper air reports.

Interfaces to both the NSSFC AFOS and the CRH AFOS exist. These interfaces allow products created at NSSFC to be disseminated over the AFOS network. Both charts and forecasts are transmitted this way.

The WMSC interface serves as the principal data source at NSSFC. Surface data, rawinsonde data and pilot reports are all obtained through this interface. This interface also serves as the main dissemination device for the aviation products.

Efforts are being made to get a second Data General Eclipse system to ease some of the current overloading problems as an interim measure until the National Center Upgrade can take over these functions. A Data General MV-4000 computer is being procured to serve as a back-up for the S-230. The MV-4000 will be slightly faster than the S-230, have 6 megabytes of memory and two 356 MByte disks when fully configured.

III.B. AFOS

NSSFC has two WSFO two-computer AFOS configurations. There are nine work stations (one A3G, five A2G, one AG, one AAG, and one AK) connected to the computers. Also the NSSFC AFOS systems are augmented by two tape drives and three 10 megabytes disks. AFOS is interfaced to the Eclipse system (Fig. 2). AFOS is the principal source of NMC products at NSSFC. Virtually all of the synoptic examination functions are performed on the system. A DIFAX facsimile circuit supplements the NMC products displayed at the NSSFC. The Eclipse/AFOS link is used to allow products generated on the Eclipse to be disseminated over AFOS.

CRH also has a WSFO two-computer AFOS configuration. The CRH has four work stations (three AK, one AGG) connected. The primary function of this system is regional monitoring. This function will not be part of the NSSFC upgrade. The CRH system is interfaced to the Eclipse system (Fig. 3). This interface allows the CRH to serve as a backup AFOS dissemination function of the Eclipse system.

C-2

III.C. EAS

The Electronic Animation System (EAS) is a micro-processor (Motorola 6800) controlled display system that animates the satellite imagery. The heart of the system is a large double-sided disk, holding 300 tracks (images) per side (Fig. 4). Video images are recorded on the disk by a system of multiple read/write heads which include fixed heads as well as one movable head on each side of the disk. Each head generates an independent channel of video output. Image sequences (generated by the movable heads) can operate in two modes: forward and then reverse or forward only (flyback). Images stored beneath the fixed heads (two more channels) can be combined (overlaid) with either animated sequence, a feature which allows grids to be corrected. The various combinations result in eight channels of video which are sent to channel select switches and then to the output monitor.

Input video signal is generated by a camera at the Data Entry Station (DES). This camera also contains the master synchronizing source for the system. By applying an external synchronizing signal to the camera, it may be gen-locked to that external source. Up to seven external signals can be input into EAS and distributed to the work stations via a channel select switch.

The Data Interpretation Station (DIS) is the remote controller used by the meteorologists. It communicates to EAS through the DES and can be locked out when the DES operator is entering pictures. The DIS has a trackball to control a video cursor. The primary use of the EAS is to maintain long duration animated sequences of satellite imagery. Both GOES-East and GOES-West loops are maintained showing continental views of the previous 24 hours satellite imagery.

The EAS is owned, operated, and maintained by NESDIS through a contract with G.E. Matsco. Although NESDIS is in the process of procuring a national upgrade of EAS type equipment, current plans do not include the NSSFC as an installation site. The current function of the EAS will be taken over by the National Center Upgrade system. The G.E. Matsco contract also provides for the monitoring of the GOES TAP phone line distribution to the approximate 75 users over a 21 state area. This sectorized satellite imagery distribution is transparent to the NSSFC operations. It is a NESDIS responsibility and it is assumed not to be part of the National Center Upgrade.

III.D. CSIS

The CSIS is an experimental four computer network which gives the operational meteorologist interactive capability and access to digital satellite data. It is built around 24-bit Harris/6 computers with 384,000 bytes of memory. Each computer controls a 300 megabyte disk and a tape drive. There are four interactive imaging work stations and four interactive non-imaging terminals connected to CSIS (Fig. 5).

One of the computers serves as a data base manager (DBM). Its function is to ingest data, decode it and store it in an accessible manner. The other three computers are applications processors (AP). These computers control the terminals. The AP's have access to the DBM. Most applications programs are run on these computers. CSIS was structured in this fashion so that data storage is not impacted by applications programs.

The imaging terminals each include an Intel 8085 microprocessor. Two of the terminals have storage for 42 image frames and 13 graphic frames. The other two have 64 image frames and 32 graphic frames. The image frames are six bit storage while the graphics frames have three bits. Each terminal has a keyboard, joysticks and a data tablet for input. Output is via a CRT, a color television monitor and/or a medium speed printer. Images can be colorized (via a false color lookup table), animated, manipulated and interlaced. A cursor can be used to obtain point locations within the image in any of four interrelated coordinate systems (pixels, image pixels, latitude longitude and location name). The graphics frames can be overlain upon the images. The non-imaging terminals consist solely of a CRT and a keyboard.

The DBM is presently connected to a GOES-East mode "A" satellite antenna system. Through this means, direct digital satellite data is ingested in real time into CSIS. The DBM is also connected to the FAA "604" line. This teletype circuit carries conventional data (surface observations, rawinsonde observations, pilot reports, aviation forecasts). There are also two auto-dialers hooked to telephone lines. These enable CSIS to obtain Kavouras radar data and lightning location data from the summer time Bureau of Land Management network in the western U.S. There is also an interface to the NSSFC Eclipse S230 computer. This interface gives CSIS access to AFOS and to the NOAA 360/195. A dial-in telephone port and a card reader are also present. Data ingestion is either by a clock-controlled schedule or by user request from a terminal.

The APs use the data stored in the DBM to generate products. The satellite data is sectorized, enhanced (in colors) and digitally manipulated. Routines exist to treat radar data in a similar manner. Radar data can be remapped into the satellite projection. Also composite presentations from more than one radar can be created. Satellite and radar data are stored as images. The "604" data can be listed, sorted, plotted, manipulated algebraically, contoured and mapped into various map projections.

The APs, in response to operator commands, totally control the terminals. Display and animation of terminal stored products are functions of the host computer. Responses to all operator interrogations of a terminal come from an AP, because of this the terminals are not classified as intelligent.

One unique feature of CSIS is that it is designed to operate in a "fail-soft" mode. The hardware on all four computers is functionally identical. Only software determines whether a CPU is an AP or a DBM. Terminals can be reconnected to any CPU via a patch panel. Thus, if one or more computer fails, the system can be reconfigured through a simple change of switch settings. Total failure of CSIS is highly improbable.

While CSIS is experimental, it is used in support of operations. The purpose of the experiment was to learn exactly what role an interactive computer could fulfill in the NSSFC environment. It was determined that there is indeed a need for such equipment at the center. The ability to actually manipulate the satellite imagery radiance values to estimate cloud height, motion and growth rate is useful to the forecaster. Further, the capability to rapidly create exotic analyses (e.g., equivalent potential temperature divergence) as direct overlays on the satellite image is an extremely effective tool for gathering information from our measurements. The ability to exactly locate cloud features not only with respect to its geographic location but also with regards to synoptic features is invaluable.

III.E. RADAR RECEIVERS

Radar data is available by a number of means. Manually digitized radar observations are received over AFOS and manually plotted every hour into a national composite (because the national composite from NMC is not available in a timely fashion). Individual radar imagery can be accessed

via dial-up services. CSIS has access to radar via the Kavouras network switching center in Minneapolis, Minnesota. A stand alone Kavouras radar system is also available at the NSSFC. An autodialer allows direct access to 96 radar sites equipped with Kavouras transmitters. In addition, two stand alone NWS Radar Information Display (RADID) systems allow access to the FAA's Radar Remote Weather Display System (RRWDS).

Access to NEXRAD type products have been made available to the NSSFC on a test basis via a remote terminal. This terminal is not a permanent installation.

IV. SCOPE OF SYSTEM UPGRADE

IV.A. TIME FRAME

It is anticipated that the National Centers Upgrade will be part of the AWIPS-90 budget starting in FY 1986, with physical installation of the NSSFC system by 1988. The system will have to meet the requirements of the NSSFC through the late 1990s.

IV.B. EXTENT OF SYSTEM UPGRADE

The current computer systems at the NSSFC have been developed in a piece meal, uncoordinated fashion. It is envisioned that the National Center Upgrade system will replace the entire current system of computers and interactive terminals. This would include the Data General Eclipse systems, the AFOS terminal display functions (but not the AFOS communication functions), CSIS, the EAS, and the radar receivers. It is envisioned that future systems and requirements would be interfaced to the basic National Center system such that an integrated system approach would still be preserved, i.e., future data sources and future product requirements would be incorporated into the National Center system without stand alone work stations or processors. This dictates a modular system design with well defined interfaces. Likewise, the system needs to have spare cycles, memory space, and disk space at the time of delivery so that gradual growth and developments can take place. It is envisioned that the National Center system will be allowed to evolve during its lifetime.

IV.C. ANTICIPATED FUTURE EXPANSION

There are several factors which necessitate changes to the system over its lifetime. While it is difficult to fully anticipate future changes and their impacts, the following are some of the factors which must be considered.

IV.C.1. Organizational Changes

Currently there are no planned changes in the roles of the NSSFC. However, it must be noted that the mission of a national center evolves to meet the urgencies of the situation. During the last six years, four major changes in the NSSFC mission have occurred. The TDU research unit was established in 1976. With this addition, the computer demand at the center increased markedly. During 1978 the radar development unit (RADU) was disestablished. In its stead, the convective SIGMET unit with its mission was begun. This unit significantly altered the communication needs of NSSFC operations. All responsibility for local weather products was removed in 1979, when the Public Service Unit with its radar observation program was relocated. This obviated the need for direct communications from NSSFC to the local Kansas City media. In 1982, the aviation area forecast program of the NWS was centralized at NSSFC. This program again incremented the processing demands at NSSFC.

Recently there have been informal investigations into the possibility of transferring the national flash flood forecast responsibility to the NSSFC and expanding the verification program to include all types of watches and warnings. While no decision has been made yet on these additional responsibilities, the message is clear that the possibility exists for additional national forecast units to be added to the NSSFC.

The limiting factor in how many new responsibilities will be added to the NSSFC over the next 15 years will probably be floor space. With the anticipated elimination of the communications center and the EAS equipment room, there would be sufficient floor space for up to two new functional units. Hence, for planning purposes, it is conceivable that the current work environment of five units with ten work stations working round the clock could be expanded to seven units with 14 to 16 work stations. Hence, the National Center Upgrade system needs to have at least a potential 50% growth capability over its lifetime to account for organizational changes.

IV.C.2. VAS

The VISSR Atmospheric Sounder (VAS) is currently an experimental program on the GOES geostationary satellite. It is anticipated to become operational during the mid-1980s. VAS will provide remote temperature soundings in clear air

throughout the day. It also will provide the visible, infrared imagery currently supplied by GOES and have additional imagery bands available such as atmospheric water vapor.

The VAS program development plan calls for a VAS Data Utilization Center (VDUC) to be established at the NSSFC. While the main VAS sounding processing will be done at NMC and transmitted to the field, the NSSFC VDUC will need to be able to ingest the raw VAS imagery, distribute the imagery to different users within the NSSFC, communicate with the NMC VDUC for access to processed fields, and process on demand soundings and sounding products over limited regions of interest.

The VAS VDUC functions should be incorporated into the National Center Upgrade system at the very beginning of the National Center Upgrade.

IV.C.3. NEXRAD

The next generation radar (NEXRAD) system for the weather service will start to be deployed in the late 1980s and be completely deployed by 1993. This system will not only replace the present WSR-57 radars, but will also augment their capabilities with the inclusion of Doppler measurements and onsite computer processing of the radar data. The onsite radar image and products data base will be accessible remotely via dial-up phone circuits with speeds up to 4800 baud. A large selection of products will be available, such as reflectivity and velocity image displays, echo tops, wind shear, severe weather probability, gust fronts, icing, etc.

The current radar access is through the dial-up capabilities of the NWS Radar Information Display (RADID) accessing the FAA Radar Remote Weather Display System (RRWDS) or through the commercial Kavouras system. Since there will be a five year period during which NEXRAD will be partially deployed, the National Center Upgrade system will have to support both radar access systems simultaneously during this transition period.

IV.C.4. GOES-NEXT

The current geostationary satellite system (GOES) will be replaced around 1990 by a new series satellite. The government is still preparing a request for proposals for this satellite system, and the exact details of data rates, etc., will depend somewhat on the vendor selected to build

the system. The new satellite will have simultaneous sounding and imaging capabilities. The imaging system will have five simultaneous channels (visible, 11 micron window infrared, split window low level water vapor, 6.7 micron high level water vapor, and 3.9 micron near window infrared). The visible channel will have a one kilometer field of view at subpoint, the window channels will be four kilometers and the water vapor channel will be eight kilometers. The visible channel will be eight bits deep and the infrared will be ten bits. The imaging system will be able to scan the U.S. every five minutes, or the full disk every 25 minutes. The sounding system will be an infrared remote sensing system with fourteen channels. It will be able to sound the U.S. every 40 minutes. The data rate of GOES-NEXT will be approximately the same as the GOES mode AAA data (2.2 MBits/sec).

IV.C.5. Profiler

The wind profiler developed by ERL will probably be deployed in a nationwide network by the early 1990s. The profiler is a ground based microwave active sounding system. It can produce vertical wind soundings every five minutes with a vertical resolution of better than one kilometer. A test network of four wind profilers is currently in operation in Colorado. As part of the proposed STORM program and expansion of the basic weather service capabilities, a network of 70 or more profilers will be deployed by 1990. National distribution of the profiler network data will probably be hourly.

IV.C.6. Lightning

Lightning location data is currently not one of the data sets routinely used by the weather service. However, lightning location networks exist covering over half of the U.S. The Bureau of Land Management maintains a summer network west of the Rockies. The State University of New York at Albany has an East Coast network, and NSSL has a network covering Oklahoma. Outside access to these networks is generally available through dial-in ports over 300 or 1200 baud lines.

The technology for sensing lightning location is new and has not been standardized. Several groups in the government operations and in the research field are actively developing systems and networks. The weather service is looking into the technology of sensing lightning with the ultimate goal of producing lightning forecasts. It seems highly possible that lightning location will be one of the basic data sets available in the 1990s.

IV.C.7. Automated Surface Observing System

The deployment of Automated Surface Observing Systems (ASOS) is aimed toward further automation of observations. The principle goal of this program is to replace or augment the human observer at selected weather observing sites. While the current goal is to replace existing human observers, it is not inconceivable that automated observing stations would be deployed beyond the current surface observation stations.

IV.C.8. AWIPS-90

The Advanced Weather Interactive Processing System for the 1990s (AWIPS-90) will replace the current AFOS communications network in addition to replacing the interactive AFOS display capabilities. The National Center Upgrade system will initially communicate with AFOS and then with AWIPS-90 when it is deployed. The basic communication system will probably change from a land based ring configuration to a satellite based system. It will probably have a high bandwidth broadcast function from a central site to all the field sites with a limited bandwidth return from each NWS office. Specifications for the AWIPS-90 communications are still being developed.

IV.C.9. ARF

The Aviation Route Forecast (ARF) is a digital gridded weather product designed for direct user access. The concept is being developed as part of the FAA's National Service Automation System. Forecasts are entered into a digital grid which are stored. When a pilot requests a briefing, route processing software retrieves the grid values along a corridor around the route he will be flying, and a briefing is assembled. ARF will allow site specific, user specific forecasts to be assembled by computers without manual intervention by a weather brief.

The FAA has been developing the ARF concept through contracts with the MITRE Corporation. This has included prototype forecast entry work stations as well as pilot briefing terminals. The goal is to have an operational system by 1987. The decisions as to which forecast offices will be responsible for the general forecast entry into ARF grids have not been made yet. However, since the NSSFC has some aviation forecast responsibility, it should be assumed that the forecast products produced by the NSSFC will have to be put in ARF grids. Hence the National Center Upgrade system

needs to have the ability to prepare and disseminate forecasts on ARF grids.

V. REQUIREMENTS

The following are the perceived requirements for the National Center Upgrade at the NSSFC. Many of the requirements are reflections of current capabilities on one or more of the current systems. The following requirement section will try to include the basic requirements, a brief explanation of the reason for the requirements, the critical factors associated with each requirement such as timeliness, data volumes, etc., and a brief description which and how the current systems handle these requirements.

V.A. INPUT DATA

The NSSFC needs a large number of input data from a variety of sources. These data must be collected, processed, and displayed in a timely fashion in order to monitor the evolving weather situation.

V.A.1. Surface Data

Surface observations are one of the principal quantitative data sets used by the NSSFC. Such observations include readings of temperature, dewpoint, wind velocity and direction, sea level pressure, altimeter setting, ceiling height, cloud amount, visibility, any occurring weather, and added remarks. Surface observations are taken hourly at approximately 1100 sites in the contiguous United States, northern Mexico, and southern Canada. As weather conditions deteriorate observation frequency increases and special reports are transmitted. Synoptic observations are also reported by approximately 250 stations every 3 hours and summary reports every six hours. The hourly reports are used by all the forecast units, while the synoptic reports are used primarily by the National Public Service Unit.

Surface reports come from a variety of sources. About 25% of the observations originate from the NWS and are transmitted over AFOS. The rest of the observations are primarily made by the FAA and are collected at the FAA Weather Message Switching Center (WMSC). The current WMSC is in Kansas City, but future plans call for new centers at Salt Lake City and Atlanta by 1986. Data from the FAA and the NWS are relayed to each other through the NWS-System Monitoring Control Center's Gateway. The NSSFC provides the operational backup for the Gateway. The WMSC uses an FAA developed synchronous protocol.

Surface reports currently enter the NSSFC through a number of different circuits. The Eclipse has a direct synchronous link to the WMSC. Observations are continually ingested and decoded. Over 80% of the observation reports are available during the first 15 minutes of each hour. The computer operator has a continuous status report of the observations received. When a sufficient number of reports are received, hourly maps of various parameters are produced. These map products have generally been completed by 20 minutes after each hour.

CSIS obtains surface observations from monitoring the FAA 604 teletype circuit which originates at the WMSC. Observations are continually ingested and decoded. Products are produced from the data file on demand of the forecasters and use all of the available reports up to the time of the request. The timeliness and completeness of the data from CSIS and the Eclipse are essentially identical.

AFOS also has surface observations which are primarily used as simple listing of observations because of the limitations of AFOS for locally generated derived products. The timeliness of AFOS data is essentially identical to the other two systems.

The NSSFC currently has three quasi-independent means of obtaining surface observations. Experience has shown that it is frequently possible for one reason or another that one of the sources will be inoperative while the others are supplying data. Because of the importance of the surface observations for the NSSFC operations, the National Center Upgrade system should be connected to two quasi-independent data sources, one NWS and one FAA. Data from both sources need to be continually ingested and decoded to insure operations. Because of the duplication of data, only one of the decoded data files needs to be processed.

The data volume of surface observations each hour from any one source is typically 80 to 100 kilobytes. Because of the growing number of observations made by automated stations, this volume should increase in coming years, possibly by a factor of two or more. Because of the need for time change analysis and synoptic overview considerations, the surface data must be maintained on the system for at least 24 hours. The surface data currently is archived onto tape every day. The archived surface data is used for case studies and local research programs. The National Center Upgrade system needs to have the capability to archive the surface data, read the archived data back

into the system, and support simultaneous processing of current and archived data sets.

V.A.2. Satellite Imagery

Geostationary satellite imagery forms one of the main data bases of the NSSFC operations. Data is currently received directly from GOES-East via a roof-top antenna, and from GOES-West via phone line connections to GOES-TAP and the University of Wisconsin McIDAS system. Full resolution GOES-East coverage of the entire U.S. is provided from CSIS. Continental coverage by GOES-East and West is currently provided by the EAS displays. The National Center Upgrade system needs to provide full resolution GOES coverage from at least longitudes 65°W to 128°W , latitudes 24°N to 49°N . For synoptic surveillance, data with at least a 4 km resolution must be maintained over the area 50°W to 170°W longitude, 60°N to 10°N . Since no one satellite can adequately cover this region, both GOES-East and GOES-West data is required.

The current GOES satellites have a visible channel with a 1 km field of view and a window channel infrared channel with a field of view of about 8 km (which is over-sampled to 4 km for transmission). The current mode A data rate is 1.8 megabits/sec. Normal operations provide a new GOES image from each satellite every half hour except during severe weather RISOP mode when data is provided every 15 minutes. Research data sets are frequently produced with frequency as often as every three minutes.

When the National Center Upgrade is operational, the VAS instrument will be operational and the mode AAA will be the normal GOES transmission operations. Mode AAA will have a data rate of 2.2 megabits/sec, 1 km visible data, two simultaneous infrared channels, and a data block of approximately 120 kilobits per spin or 27 megabytes per image. Multiple spins per line allow the VAS to produce multiple infrared channels. The National Center Upgrade system needs to be able to ingest GOES mode AAA from both satellites, extract the visible, 11 micron infrared and at least one other infrared channel (such as water vapor) for display purposes, extract the multiple infrared channel data for sounding retrieval and other VAS processing, and extract the auxiliary data block. The auxiliary data block will contain some processed VAS data and other meteorological data of interest.

The VAS allows very flexible scanning schedules for the GOES satellite. The National Center Upgrade System needs to

have the capability to ingest any of the scanning sequences which the GOES satellite may be used in. This would include rapid scan sequences, multiple spin sounding sequences, etc.

As discussed in Section IV.C.4., GOES-NEXT will become operational during the lifetime of the National Center Upgrade system. It will have simultaneous sounding and imaging capabilities, more channels, and more frequent scanning. The system needs to be expandable to include GOES-NEXT data. Since both GOES satellites will probably not be replaced simultaneously, the system needs to be able to support one GOES-VAS and one GOES-NEXT simultaneously during the transition period.

The current policy of maintaining a two geostationary satellite system is enforced by limited lifetimes of the satellites, and the cost of ground station equipment. Research and severe storm forecasting efforts would be greatly benefitted by a third GOES-Central satellite. While it is improbable that this would happen any time soon, it is conceivable that this could occur during the lifetime of the National Center Upgrade system. The ability to expand to ingest three simultaneous GOES satellites would be a desirable, but not required, feature of the National Center Upgrade system.

The data storage requirements for the National Center Upgrade system will largely be dictated by the volume of stored satellite data. The full resolution visible requirements stated in the previous paragraphs require an array of approximately 2400 lines by 6000 elements, or 14.4 megabytes per image (the six-bit visible data is stored as an eight-bit byte) for each satellite. The 4 km resolution data requires an array of approximately 1200 lines by 2400 elements or 2.9 megabytes per image for each satellite. The infrared is currently transmitted as a 4 x 8 km pixel, and stored as a 4 km pixel even though the radiometric field of view is 8 km. The storage requirements are based on a 4 km infrared pixel storage.

A 24 hour storage of the 4 km data base is required for synoptic surveillance purposes. A time interval of 30 minutes between images is required for this data base. During severe storm operations, RISOP data is obtained every 15 minutes. The NSSFC operations require a three hour sequence of the full resolution data. The GOES satellite can transmit at higher time resolutions. While the NSSFC operations do not currently ingest rapid scan data, and does not have an absolute requirement for this data, it would be highly desirable to have this capability in the National

Center Upgrade system. Rapid scan data of five minutes between images would need to be stored for the previous one hour.

VAS ingestions will add a second infrared image (generally the water vapor) for storage and distribution to users. In addition, dwell sounding data would be ingested for computations of VAS retrievals and other products. The 12 VAS channels at 14 km resolution can sound the U.S. every 1 1/2 hours with current transparent VAS operations. This would require an array of at least 300 lines by 600 pixels to cover the area of responsibility. The VAS data is stored as 16 bit data. Each VAS U.S. data set thus requires 4.3 megabytes of disk storage. This data needs to be kept for one day.

The following is the anticipated satellite image storage requirements for the National Center Upgrade system. It assumes a worse case rapid scan operations on both satellites.

| | |
|------------------------------------------------------------|----------------|
| a. 1 hour visible U.S. every 5 minutes | 346 megabytes |
| b. 1 hour IR U.S. every 5 minutes | 22 megabytes |
| c. 3 hour visible U.S. every 15 minutes | 346 megabytes |
| d. 3 hour IR U.S. every 15 minutes | 22 megabytes |
| e. 24 hour IR hemispheric every 30 minutes | 276 megabytes |
| f. 14 hour visible hemispheric every 30 minutes | 161 megabytes |
| g. 24 hour water vapor (8 km) hemispheric every 30 minutes | 69 megabytes |
| h. 24 hour VAS U.S. dwell soundings every 1 1/2 hours | 69 megabytes |
| | <hr/> |
| TOTAL | 1311 megabytes |

When GOES-NEXT becomes operational, the basic storage requirements will remain valid. Additions due to increased IR imaging channels would add 552 megabytes. The increased sounding frequency would add 69 megabytes. The 10 bit word length of the IR would add 97 megabytes to the basic data storage and an additional 138 megabytes to the additional IR imaging channels. The basic storage requirements already

handle the rapid scan and higher spatial resolution of GOES-NEXT. Hence, GOES-NEXT will be expected to increase the satellite data storage requirements by 856 megabytes.

The system will not have an archive requirement for GOES data as this is being done by NESDIS. However, the system needs to be able to save and restore selected data sets for use in research and case studies. The system needs to have the capability to store at least one research data set in addition to the operational data sets. A research data set will be defined as three hours of 15 minute data from one satellite, or 194 megabytes of data. In addition to the capability to save and restore locally received satellite data, the system needs to have the capability of reading tapes of satellite data obtained from the official U.S. GOES archive at NESDIS.

The satellite data needs to be available in near real-time. Current operations of the GOES has the starting scan of the U.S. at three minutes after the half hour, and completing it by six minutes after. Current CSIS capabilities start loading satellite imagery at six minutes after the half hour and have completed all the various loads to all the various terminals by ten minutes after the half hour, or four minutes after availability of the data. As part of the requirements on the terminal load times in a later section, this four minute time period to load all the images would go to three minutes.

V.A.3. Radar Data

Along with surface observations and satellite imagery, radar forms the backbone of the information required for weather monitoring. These data are currently available in two forms, both of which are required for any future system.

National radar coverage is provided by the manually digitized radar (MDR) coded observations. These observations are taken nationally every hour on the half hour. The observations are on a grid of approximately 22 nmi resolution which contain the maximum reflectivity within the grid cell. Information on echo heights and movements is appended to the messages. AFOS is used to transmit the observations. The NWS guidelines for issuing SIGMETs specify MDR thresholds as criteria for issuance of SIGMETs. These SIGMET messages must go out at ten minutes before the hour. While a national composite of MDR data is produced in Washington and transmitted over AFOS (and routinely used by the NPSU), it is not timely enough to be useful in issuance of SIGMETs.

Consequently, the MDR data is hand plotted as it is received over AFOS and is generally available 20 minutes before the hour.

Radar images for any specific site are available via dial-up services from over a hundred separate locations. Current capabilities use a Kavouras receiver, a dedicated CSIS interface to the Kavouras network, and two Weather Service RADID displays. These radar image products have an image size of 256 x 256 pixels, with threebits per pixel (25 kilobytes per image) and are received over a voice grade phone line (either 1200 or 2400 baud depending on the system used). The data generally take one to four minutes to be ingested into the system. Each radar has a limited diameter of coverage of about 250 nmi. Several radar sites are generally required to cover the area of interest of a forecaster, so the ability to ingest several radars, remap them into a common projection and display the resultant loops is required. CSIS currently provides this remap capability in a satellite projection. Radar loops are frequently displayed with satellite loops.

The radar image data is used in several fashions by different forecast groups. The SIGMET section use the radar image data to clarify and localize the information received from the low resolution MDR product (the MDR has a severe smearing of individual cells). The SELS forecasters monitor the radar along with the satelliteto determine the initial occurrence of convection in an area suspected of potential severe weather. The radar is also used to determine if watch boxes should be extended or the placement of new areas inside regions which have had heavy convection with extensive cirrus blow off.

The National Center Upgrade system needs to access the raw coded MDR data from AFOS, any national radar composites from NMC, dial-up radar image data, and NEXRAD image and graphic products. The MDR data needs to be received, processed, and displayed in a national composite within 10 minutes after the beginning of data reception (within two minutes after the end of data reception). The radar image data needs to be ingested from a number of separate sites, remapped and composited. The frequency of radar data needs to be consistent with the frequency of satellite coverage (15 minutes between images). Two separate forecast units (SELS and SIGMET) require access to radar data loops (either in original projection, or as composites), while a third (SFSS) could make use of the radar data on occasion. At least two and frequently three radars are needed for the composite by each forecast unit. Hence, the National Center

Upgrade system needs to be able to access and process at least six radar sites every 15 minutes. A growth potential to access and process an additional six sites (12 total) every 15 minutes would be desirable for support to the SFSS and potential future missions. The radar image data needs to be maintained for three hours to maintain consistency with the satellite data, making a storage requirement of 1.8 megabytes (3.6 with growth potential).

The NEXRAD radar system will start to replace the current radars by the end of the decade as described in section IV.C.3. The system needs to be able to support both the current radar access and the NEXRAD access during the transition period when NEXRAD is being deployed. The system needs to have the ability to access any of the NEXRAD products available to remote users. The NEXRAD products most likely to be used routinely by the NSSFC units will be the processed products such as the composite hazards chart. The system needs the ability to access at least three NEXRAD products per site for six sites every fifteen minutes. An expansion capability of either the number of products or the number of sites would be desirable.

The system needs to be able to save radar data. The ability to save image data should parallel the requirements of satellite, i.e., the ability to save the current data set and the ability to restore and process both current and historic data sets.

V.A.4. Pilot Reports

Quantitative reports of in-flight weather conditions directly transmitted by pilots form one of the primary data bases of the aviation forecasters at the NSSFC. Approximately 3500 reports of about 320 bytes each are transmitted a day (1.1 megabytes a day). They contain information on turbulence and icing in addition to cloud cover, heights, bases, winds and temperature. Of the reported conditions, less than 10% are of portentous conditions of turbulence or icing and require immediate attention. Primary transmission of pilot reports is via the FAA circuits.

The primary current use of the pilot reports is for information on turbulence and icing. Current capabilities of CSIS and the Eclipse AOS include complete listings of reports and edited listings of reports containing turbulence and icing information. The aircraft meteorological information is not routinely processed because of the extensive manual editing required of the pilot meteorological

observations, and the non-synoptic nature of the observations. New systems such as ACARS and ASDAR promise an improved meteorological data base if they are ever deployed in sufficient numbers.

The National Center Upgrade system needs to have the ability to receive and decode pilot reports. Reports with icing and turbulence information need to be made available to the aviation forecasters as soon as they are decoded. The ability to decode the meteorological parameters should be included to support potential future efforts at generating an aircraft meteorological data base, and should have access to ACAR and ASDAR reports.

The system should have the ability to archive messages which contain reports of moderate or greater turbulence, moderate or greater icing, or low level wind shear, read these archived data back into the system and process both current and historic data sets.

V.A.5. Plain Language Messages and Coded Forecasts

Severe weather warnings, statements, summaries, forecasts, etc., are transmitted over NWS circuits and represent an important information source for all the forecast units. Message headers are used to route the messages to the appropriate forecast unit. Current operations use AFOS CRT displays or printers to read the various messages. For instance, SELS gets a printer output of all severe weather warnings and statements, which is used to update the SELS log of severe weather activity. The NPSU scans various statements and summaries on AFOS to obtain the background information required for the national summary products.

The total AFOS message traffic is approximately 14 megabytes per day, which represents a current upper bound on message traffic to be handled. (Since AFOS communication channels are currently saturated, if the communication rate is increased in the future, the potential exists for increased message traffic demand.) Additional message traffic is also currently received from FAA sources. Much of the current message traffic is not used by the NSSFC.

The National Center Upgrade system needs to have the ability to monitor message traffic and route appropriate messages to different work stations. The system should have the capability to store and display messages for the length of the duty cycle of the work station (typically between 6 and 24 hours except for verification activities which require an archive of messages). The system should have the

ability to decode selected types of messages and automatically enter events into a log. (Current logging operations are manual.) Logs would include the SELS log of severe weather events and an aviation hazards log.

V.A.6. Upper Air Observations

Upper air observations are a critical piece of information for all the NSSFC operations. The principal current source of upper air reports are rawinsonde observations which are routinely collected and transmitted every 12 hours (at 00 and 12 GMT). There are approximately 100 rawinsonde stations over the section of North America that the NSSFC has responsibility for. These data contain temperatures, dewpoints, wind direction, and speeds for various vertical points (typically 50) over each station. Rawinsonde information is contained in about 80 kilobytes and is transmitted twice a day. The data flow is essentially limited to 90 minute spans. Upper air observations are received via FAA Switch (WMSC) on the Eclipse, the FAA 604 on CSIS, and the AFOS.

While rawinsonde data is the only current source of upper air information, VAS soundings and Profiler wind soundings will be available routinely during the lifetime of the National Center Upgrade. VAS soundings and sounding derived products will be routinely available from NESDIS starting in 1986. These will provide upper air observations in clear regions throughout the day. Approximately 200-300 temperature and moisture soundings per hour could be produced with approximately ten levels of information. The wind profiler is a ground based active microwave wind sensor. A network of over 70 profilers may be in place starting in 1988. The profiler will have all weather capabilities. While wind data can be obtained every five minutes, the data available routinely to locations such as the NSSFC will probably be hourly. Approximately 20 levels of data can be obtained from the profiler. Plans for distribution of VAS and profiler data have not been made yet, but will probably be over conventional means of data communications.

The National Center Upgrade system must be able to ingest, decode and store upper air observations from the U.S., Canada, and Mexico. Rawinsonde, VAS and profiler soundings should be ingested and processed. The option to include or exclude various types of upper air observations will need to exist for processing algorithms. Because of the needs for synoptic overview and change analysis, the upper air soundings need to be kept on the system for at

least 36 hours and then archived in a manner similar to the surface observations. Also, similar to the surface observations requirements for two semi-independent paths of data entry, the rawinsonde observations should be available from two sources.

V.A.7. Centralized Charts

Charts distributed over the national NWS circuits form an integral part of the NSSFC data base. These NWS produced charts consist of analyzed fields (such as upper air observations), forecast products, and other graphical fields (such as the national radar composite). These charts are used by all the forecast units in the NSSFC. Previously these charts were received over a DIFAX line with hard copy output. The current operations have these charts coming mainly from AFOS displays. They are viewed either on the AFOS video display or printed and put on the wall. Wall mounted charts are saved for the month and then stored for use in case studies.

AFOS transmits charts using a line segment vector graphic technique. Future systems such as AWIPS-90 are expected to transmit chart information in a digital gridded format with the local processor drawing the lines through the gridded fields. Likewise many of the locally generated graphical displays described in later sections will use grids as an intermediate product.

The current AFOS graphics represent about 3 megabytes of data per day. Storage of locally generated intermediate grids will require approximately 13 megabytes additional. The National Center Upgrade system must have the ability to collect, store, and display charts generated externally and transmitted over AFOS. It must be able to be modified to accommodate charts or grids intended for chart generation which will be transmitted over AWIPS-90. It must have the ability to produce inexpensive wall mountable hard copy of these charts in addition to video displays.

V.A.8. NMC Fields

In addition to forecast fields received as charts over AFOS, the NSSFC requires additional numeric guidance products which are not available over AFOS. A remote job entry (RJE) port into the computer complex at the NMC is currently used to obtain these forecast fields. The fields are obtained either as an analyzed map composed of alpha-numeric characters and printed on the AOS system printer, or as a gridded field and transferred to CSIS for video

display. Currently about 200 fields, twice per day, are obtained from NMC. This number is expected to increase in coming years. In addition to more operationally produced fields, it is anticipated that experimental mesoscale numerical model evaluation activities will require substantially more gridded fields sent from NMC to the NSSFC. As many as 600 grids of 1.6 kilobytes each could be expected twice per day, for a data volume of 2 megabyte per day.

The National Center Upgrade system needs to communicate with the NMC computer complex over a moderate speed link (9600 baud or greater). It must be able to receive, store, and display data produced at NMC. This NMC data could take the form of alpha-numeric observations or gridded fields. In addition, a capability to remotely program the NMC computers and to receive printed alpha-numeric output from NMC is required.

V.A.9. Lightning

As discussed in section IV.C.6., there exists a possibility that lightning may be one of the data inputs to the NSSFC during the lifetime of the National Center Upgrade system. As part of a NASA sponsored experiment, the NSSFC has received lightning data from the Bureau of Land Management network in the Western U.S., and judged the data to be useful. Lightning data is accessible remotely via dial-up phone connections and asynchronous protocols.

If, when, or how a national lightning location system would be developed is still not clear. It is desired that the National Center Upgrade system have expansion capability to allow future dial-out phone circuits (up to four) for lightning data collection.

V.A.10. Data Collection Platforms

The GOES satellite has the capability to relay data from remote data collection platforms. This capability is currently being extensively used at remote sites for river level monitoring instruments, buoy instruments, etc. None of this data is of interest currently to the NSSFC. However, the capability seems ideal for future deployment of remote automated surface observations, and as such may represent a future source of data.

The GOES data collection platform data is received via a standard GOES antenna and receiver, but with different electronics after the receiver. It would be desirable that the National Center Upgrade system have capability to add a data

collection platform interface at some future date. Data volume would probably be less than two megabytes per day.

V.A.11. Input Data Summary

The following is a summary of the anticipated data inputs into the National Center Upgrade system. Table 1 lists the various data connections envisioned, types of data collected, line data rates, protocols used, and status of current usage.

V.B. Output Data - Forecasts

The main output product from the NSSFC consists of forecasts and watches. These are alphanumeric text data which must be transmitted to AFOS (and AWIPS-90), the NMC computer complex, and the FAA Weather Message Switching Center. Each of the five NSSFC forecasting units generate forecast messages with the length and frequency varying between units. Convective SIGMET messages go out hourly, aviation area forecasts (FA) go out three times per day, the NPSU Weather Summary reports go out four times per day, the SELS watches go out as needed, the SELS convective outlooks go out three times per day and the satellite interpretation messages go out four times per day. The text length varies according to the product but can be up to several pages long.

Forecast preparation is a major part of a forecaster's duties and needs to be made as time efficient as is possible. The National Center Upgrade needs to assist the forecaster preparing the messages by using word processing capabilities and graphical message generation assistance. The system also will need to support ARF type output products.

V.B.1. Forecast Text Preparation

The National Center Upgrade system will require word processing capability similar to standard secretarial word processing systems. Some of the required features would be:

- o ability to automatically perform carriage returns and line feeds as one types

- o ability to use "speed typing" where simple codes and/or keys are automatically expanded into stock words, phrases, sentences, or paragraphs

- o ability to easily cancel a command either before or after it has been requested (an undo function)

- o ability to use pre-formatted forms fill-in

- o ability to scroll up or down a document either by line, paragraph, or page

- o ability to rapidly and easily locate the text which requires editing, such as using a cursor to locate the word, line, sentence, paragraph, etc.

- o ability to edit and delete characters, words, lines, sentences, paragraphs, pages, etc.

- o ability to insert characters, words, sentences, paragraphs, etc.

- o ability to highlight and/or correct spelling errors using a programmable spelling dictionary

- o ability to store and edit documents in user definable names

- o ability to search for and locate characters, words, phrases, etc.

- o ability to move characters, words, lines, sentences, phrases, paragraphs, etc.

- o ability to handle multiple messages composition simultaneously from a single terminal and switch quickly and easily between the separate message (up to six simultaneous messages being processed)

- o ability to copy and move phrases, lines, sentences, paragraphs, pages, documents between the separate messages

- o ability to easily switch between word processing mode and system command modes.

- o ability to accept textual information generated by processes other than keyboard data entry (such as graphic processor described next).

V.B.2. Forecast Preparation Using Graphical Inputs

Forecast messages contain frequent mention of geographically oriented information, such as lists of cities or regions affected by the forecast. This information can

be most rapidly generated using interactive graphical means. A current example on CSIS is the generation of the SELS tornado or severe storms watch areas. The program allows the forecaster to put a watch area on the graphic overlay on top of the satellite and other displayed information. The system then allows the forecaster to interactively reposition and/or change shape of the watch area until it is oriented exactly over the area of maximum threat. The computer will then give the forecaster the geographic information necessary for the watch message (such as: 70 statute miles either side of a line from 20 miles south of Burlington, Iowa to 40 miles east-northeast of Benton Harbor, Michigan, and the latitude/longitude locations of the four corner points). Another example would be in order to define a region of a forecast, the forecaster would draw a line on the interactive graphics and the computer would locate the string of weather station offices (or other appropriate landmarks) closest to that line which could be used as a textual description of the line.

V.C. Data Processing

An extensive amount of data manipulation is required for the National Center Upgrade System. Data must be ingested, decoded, checked, stored, retrieved, manipulated, intercompared, and displayed.

V.C.1. Sizing of Processing Development

The sizing of the computer processing requirements is difficult to do in detail at this time. One measure of the required computer sizing and development task is the existing systems at the NSSFC. The National Center Upgrade System must take over all the functions of the combined current systems. While there is a minor amount of overlap between current system functions, it is not significant. The current systems have consumed all current capacity so that any new system needs significantly more capacity than is currently available.

The current CSIS package has 1380 major software modules with 194,000 lines of code. The AFOS system has approximately 100,000 lines of code in the basic system and display functions used at the NSSFC. The AOS operational code is estimated at well over 100,000 lines of code although an actual count of lines is not available. While some code may be able to be salvaged from current systems, it is unlikely that extensive amounts of current code will be utilized in the National Center Upgrade System because of the basic differences and incompatibilities among the current systems.

Hence, a development effort of well over 400,000 lines of code can be anticipated for the National Center Upgrade System at the NSSFC.

The sizing of the computer requirements needs to be based on processor load requirements and timeliness requirements. The current system has eight computers with a combined processing speed of approximately 2.4 million instructions per second and disk storage of over 2.5 gigabytes. As mentioned, the current systems are inadequate, so the National Center Upgrade must anticipate significantly more computer resources than are currently available.

As part of sizing the computer processing tasks for the National Center Upgrade System, the following is a brief description of the basic processing requirements.

V.C.2. Data Ingestors

Ingestors are required for all the input data types discussed in section V.A. This includes surface hourly observations from two quasi-independent sources, geostationary satellite imagery from two antenna sources, manually digitized radar data, dial-up radar data, pilot reports, plain language messages, coded forecasts, radiosonde observations, VAS sounding products, profiler products, centralized NWS distributed AFOS charts, NMC gridded digital forecast products, and probably lightning data collection platform, GOES-NEXT, and NEXRAD products. Refer to section V.A for details on the different data types and Table 1 for data speeds, protocols, etc. Format information on each of the data types required for writing ingest software will be provided in later documents.

As part of the ingest systems, provisions must be made to scan product header records and determine if the product should be ingested. As part of the AFOS ingestor, currently over 7500 separate header identifiers are ingested. The current system allows growth to up to 10,000 headers. Other data sources such as FAA products require header record identification, but are much more limited in number of headers as compared with AFOS.

V.C.3. Decoders

Many of the data products require decoders to extract the required quantitative information from the text originally designed for manual reading. Decoders currently in use include a surface hourly observation decoder, a ship

and buoy decoder, a mandatory level radiosonde decoder, a significant level radiosonde decoder, a terminal forecast decoder, a manually digitized radar decoder, a pilot report decoder, a remarks decoder, a FP4 forecast decoder and special decoders for Mexican and Canadian data sources. Future plans call for FOUS R1, R2 and R3 decoders of forecast data products, and possibly decoders on watch, warning messages for use in automating verification efforts.

Decoders are required for several reasons. The primary is to process quantitative observations into a form where they can be stored by the data base management system. A second is to allow computer monitoring of message traffic and alert the forecaster to messages and conditions which require attention. For instance, pilot reports are currently monitored for remarks concerning turbulence and icing. Surface observations are monitored for remarks on high wind, sudden pressure changes, particular cloud types, severe weather, thunder, etc. These particular remarks are listed out for the forecaster. In the case of extreme conditions, the CSIS system uses a voice synthesizer to alert the forecaster to the hazard. The National Center Upgrade System requires decoders similar to those currently in use and the ability to monitor message traffic for pertinent information.

V.C.4. Quality Control of Incoming Data

After data has been ingested and decoded, it needs to be quality controlled before being filed. If carried to extremes, quality control of data can be an enormous task. While sophisticated quality control algorithms would be desirable, for most cases rudimentary checks would be sufficient. Surface and upper air data should be checked for physically realistic values. Temperatures greater than boiling, winds greater than 300 mph, etc., would be discarded. This rudimentary check could use climatological values of observations as a base line for what is physically realistic. Dew point temperatures should be checked to be less than or equal to the temperature. Radiosonde data should be checked for vertical consistency using a hydrostatic check.

In addition to the required gross error checking just described, a "buddy checking" quality control algorithm would be desirable for both horizontal planes of data, and time series of data. Data which radically departs from neighboring stations, and/or from the time history of data from a given station should be flagged in error. Buddy checking threshold criteria need to be made flexible so that

they can be changed by operators if desired. Also, the buddy checking flags should be able to be overridden by the forecaster. He should be able to see what data has been flagged and unflag it for analysis if desired.

Quality control of the high data rate image data is limited by the sheer volume of data. Satellite and radar image data should be checked for existence. Scheduled ingestors which fail to occur should be flagged such that any subsequent processing steps would not be started. Any routinely available quality figure such as bit error rates from the ingestors should be filed with the image document.

In addition to automatic quality control algorithms, the system should also support manual quality control. Individual stations or parameters within a given station's observations (such as the dew point) should be able to be flagged so as to be excluded from further processing such as on objective analysis. The flagging should be either for a given observation period, or until further notice (lists of permanently flagged stations should be readily available so that flagged stations don't get "lost" forever).

Image data quality enhancement routines should be available on demand rather than automatically executed for every image. (Image data quality is generally quite good so quality enhancement routines are not normally needed.) A routine to detect missing, noisy, or repeated lines and replace the bad line with a combination of bracketed good lines should be available on demand. Likewise, an algorithm to do an image brightness normalization to correct for sun angle changes would be desirable for demand call up, as would be an algorithm for removing stripping of the visible image.

V.C.5. Plotting and Listing of Observations

The system needs to be able to support simple plotting and listing of incoming data. Listing of data needs to be in a variety of formats and access patterns. The system should support lists of observations in various geographic regions, such as the entire U.S., the upper Midwest, South Dakota, a group of states, etc. Within any given region the system should be able to list observations which exceed any given threshold, such as temperatures greater than 90°F, dew points less than 60°F, present weather beginning with thunder, precipitation greater than or equal to one half inch, etc. The system should be able to list remarks flagged by the decoder in any given geographic region. The listing of remarks should also be able to use thresholds, such as pilot reports with moderate or greater turbulence or icing.

The system should be able to list a time series of observations for any given station (and produce graphics of a time series of any given parameter of any given station). The system should be able to list the current observations within any given radius around any given point designated on the satellite/radar image or map.

Listings should be able to be directed either to a CRT or a printer. Likewise, incoming messages such as warnings, statements, storm reports, etc., should be able to be automatically routed to either a printer or CRT. Observations or remarks which exceed critical thresholds set by the fore-caster should set off an alarm/alert device.

In addition to lists of data, the system should be able to support horizontal plots of observations on either printers, graphic devices, or as overlays on satellite and/or radar images. The printer plots should be able to use preprinted map background forms. Both surface and mandatory level upper air observations are currently plotted on base maps and then hand analyzed. In addition to plots of base observations, the system should be able to plot changes of parameters such as altimeter (pressure) changes, dew point changes, height changes, etc., over user specified time intervals (2 hours, 3 hours, 12 hours, etc.). Plots of data should be able to be used either as simple plots of numbers or as plots of observations combined with the contours of an objective analysis. The plotting routines need to be flexible enough to support complete station model plots, several parameters, or only one depending on the users needs. The system should be able to support various scales or zooms of data without overplotting. When various parameters are being plotted, color should be able to be used to distinguish between the parameters. When data is being printed on preprinted map backgrounds, colors such as black and red would also be desirable. Likewise, having wind observations printed as wind barbs or special symbols showing wind direction is highly desirable.

V.C.6. Analysis of Data

After the incoming data has been ingested, decoded, and filed, it must be objectively analyzed. The gridded data resulting from the objective analysis can then be used for further processing (such as computing parameter advection) or contoured for display. Current NSSFC systems use Barnes analysis routines. They are satisfactory for most single variant analysis tasks, although higher order multivariant analysis schemes would be desirable. Likewise,

an objective analysis scheme which flags data void regions would be desirable.

The grid resulting from the objective analysis should be treated as a fundamental data type which is filed by the data base management system. The surface data should be routinely analyzed over the continental United States and adjacent Canadian and Mexican land masses with a grid resolution of approximately 50 kilometers. The upper air grid should have a grid resolution of approximately 200 kilometers and cover at least the North American continent.

The surface objective analysis should be computed hourly for the following parameters; temperature, dew point, pressure, u component of wind, v component of wind, equivalent potential temperature, mixing ratio and altimeter change. Every three hours analysis of precipitation and snow cover should be available. In addition, grids of manually digitized radar products, terminal forecast products, observed and forecast ceiling height need to be derived from the coded messages.

The upper air objective analysis at the mandatory levels should have grids of height, temperature, dew point, u component of wind, v component of wind and the vertical component of the wind if it is available. The upper air grids need to be computed every 12 hours for radiosonde data, and up to every hour for VAS and profiler data. The upper air grids can be computed at a national location such as NMC and transmitted to the NSSFC, but some local upper air analysis capability is required as a back-up capability.

In addition to an upper air data base in pressure coordinates, several other coordinate systems should be maintained. A sigma coordinate system of height above terrain needs to be maintained for the aviation forecast sections. It needs grids of temperature, relative humidity, u component of the wind and the v component of the wind. It should have grid levels consistent with the NMC Nested Grid Model (NGM). The bottom nine levels of analysis (all levels below approximately 500 mb) should be routinely maintained in the system. A isentropic coordinate system would also be desirable. Grids of temperature, mixing ratio, u component of wind, v component of wind, pressure levels, and Montgomery stream function would be desired at five degree intervals between isentropic surfaces in the range of 275 to 340 degrees Kelvin.

Once the basic meteorological variables have been objectively analyzed, additional products should be able to be

derived from the grids using algebraic and/or finite difference manipulations. These derived grids should be able to be either scheduled or called on demand. The derived products would include streamlines, time change of any variable, vorticity, divergence of any parameter, band pass of any parameter, shear and stretching deformation, addition, subtraction, multiplication and division of any two parameters, gradient of any parameter, creation of a constant grid, creation of a grid containing only values greater than, less than, or equal to a given value, square root of a grid, etc. The derived product's utility should be able to be used to computer output grids of any meteorological equation.

Once the data has been gridded, contoured displays of the data is required. The contour interval, color, and smoothing factor should be able to be specified by the user. Likewise, the forecaster should be able to specify the display geometry. Mercator, polar stereographic, Lambert conformal, satellite, and radar image projections should be supported. Any of the contoured fields need to be able to be displayed at any given center point and at any given integer blow up or blow down factor.

In addition to the horizontal analysis just described, the system should be able to support vertical cross sections between any two points. The system should either automatically select the radiosonde profiles closest to the line between the two points or allow the forecaster to specify the desired radiosonde stations. Contours of potential temperature, mixing ratio, and wind speed should be supported. The system should allow derived products such as Richardson numbers, etc., to be calculated from the cross sectional analysis.

Another vertical display required is radiosonde single station analyses. Skew T/log P and Stueve diagrams showing temperature, dew point, and wind as a function of height with background lines of constant potential temperature, mixing ratio, and equivalent potential temperature are required. Vertical plots of wind shear, observed potential temperature, equivalent potential temperature and wet bulb temperature are also required. Computed stability indices of the SELS lifted index, K index, total-totals index energy in the "positive area" of the sounding, precipitable water, etc., are required with the sounding diagram. A one dimensional convective model would be desirable for computing potential cloud top heights, vertical velocity, hail sizes, etc. Another desirable feature would be for the system to be able to compute changes in the vertical profile

due to surface heating and display a modified profile for current conditions. Another desirable feature would be the ability to modify a sounding (without destroying the original data) and display the resulting stability parameters. This would be used to see the effects of forecast changes in the environment.

V.C.7. Geographic Data

Locations of towns, counties, state boundaries, and topography form an important background for forecast operations. The current systems at the NSSFC support a variety of geographic data bases which the National Center Upgrade System should also support.

One of the larger data bases is a file of the location of all the towns in the United States. The data base was generated at the NSSFC from detailed Rand McNally maps. It is used in a variety of ways. Whenever severe storm reports come in, the forecaster can ask the system where it is. The location, county, and distance from the nearest Weather Service Office will be displayed on the CRT, and the cursor will move to that location on the satellite image. The location of the report will also be used by forecast verification programs. The system also allows for searches of all towns within a state which start with any given combination of letters. This is useful in trying to locate misspelled town names. Another use of this data base is to locate the 20 nearest towns to the location of a cursor on the satellite (or radar) image or the 20 nearest towns closest to any given town. The distance between two towns is also a well used function in the determination of the number of separate severe storm reports.

Another geographic data base supported is the location of all the weather observing sites in North America and aircraft VOR locations. This data is also used in a variety of ways. The system can be asked the full name, location, and the cursor to be put on a map background or satellite image of any three letter weather observing or VOR site. This also includes the ability to locate positions relative to a station, such as 30 NW MCI (30 miles northwest of the Kansas City International Airport). This data base can also be used to plot the location of all the weather observing stations on the satellite or radar image. The plot can be either a large dot, the station letter identifiers, or the numeric identifiers.

Because severe storm warnings are issued on a county basis, counties form an important geographic data base.

Current NSSFC systems support a county outline file for gridding satellite and radar images and for determining if any given location is in any given county. In addition to the county outline, information is kept on the county geographic center, the Weather Service Office responsible for the severe warnings in that county, the county seat, the county area, and the county population. This information is used primarily for verification programs.

Geographic grids superimposed on satellite and radar images is a critical feature in the usefulness of remotely sensed data. The grids are computed from files of latitude longitudes forming the boundaries of states, major lakes, and rivers. In addition to the state boundaries, the system supports files showing the boundaries of SIGMETs offshore area of responsibility, the CWSU boundaries, major jet traffic ways, major highways, and river basins used for snow mapping. The National Center Upgrade needs to support the existing gridding capabilities and be flexible enough to add additional boundaries dictated by future requirements.

Another geographic file maintained deals with graphical message composition. In section V.B.2 there was discussion of message composition using graphical inputs. The forecaster draws on a map on the satellite image the box, line, etc., required for his forecast message. The system then picks up the appropriate town or location names and inserts them into the message. Current capabilities have lists of approved towns for severe storm watches and for convective SIGMETs. In the coming year, the names used in area forecast messages will be added to the system. The National Center Upgrade System should support the existing message composition capabilities, and be flexible enough to add to these capabilities in the future.

Terrain data also forms an important input to forecasters. The current system uses station elevation in the computing of upslope winds (elevation advection) in the western United States. Another terrain data base supported is a grid of elevation every 1/6 degree of latitude and longitude. This data base is used to form an image of terrain which is remapped into the satellite or radar projection. Another use of this terrain data base planned for the coming year is to compute turbulence in mountainous regions caused by high winds interacting with the terrain.

V.C.8. Satellite Data Processing

Satellite data forms one of the primary data bases for the NSSFC operations. The satellite imagery forms a

back drop for all of the other data sources as well as being used as a surveillance tool. In addition to the qualitative uses of the image data, a modest amount of quantitative processing of satellite data is necessary for the National Center Upgrade System.

The qualitative uses of satellite data require a number of different loops at various locations and resolutions. They will be described in greater detail in the section on the terminal display. The control of the loops needs to be kept quite flexible and easy to use. The forecaster should be able to specify for up to eight different loops, the earth located center point, the resolution, the number of frames in the loop, the loop which is opposite (such as the infrared loop which is opposite a visible) and the time interval between images in the loop. The loops should be able to be activated or deactivated and any loop which is active would be automatically updated with current data. The forecaster should be able to switch rapidly (less than three seconds) between loops. The forecaster should be able to rebuild loops over a new area from data stored on the system disk. He should be able to have a graphic depiction of the specified area to be rebuilt prior to the rebuilding process to insure that the specifications are correct. The loop control should also allow false color enhancements specified by the forecaster to correspond to critical thresholds to be automatically restored to the images whenever the loop is called up. Likewise graphic overlays such as state boundaries, watch boxes in effect, and other critical graphic overlays should also be automatically restored whenever a loop is switched on for viewing.

As part of satellite data processing, navigation support is a vital part for many of the uses of the system. (Navigation is the precise location of the satellite and its altitude which is used as part of the system for converting from earth coordinates to satellite image coordinates and vice versa.) The ability to quickly and easily compute the earth location on a satellite image is required for loading of aligned loops, the computation of grids for overlays, the remapping of graphics and other data into the satellite projection, the positioning of geographic data like cities, counties, etc. Parameters necessary for the navigation calculations are encoded into the infrared line documentation of the GOES data. The system needs to extract the necessary information and make it available to all processing requiring navigation information. This should also include historic data being used for case studies.

The quantitative image processing required of the National Center Upgrade System is generally little more than the extraction of a subset of digital values under the direction of the forecaster and then computing derived products rather than the intensive processing which is more typical of image processing in other disciplines. The system should be able to extract the digital values inside a cursor and display them as counts or temperatures (for infrared data). It should be able to take the temperature data from inside the cursor and compute the cloud height using radiosonde (or VAS) profiles for the conversion of temperature to height. It should be able to track cloud features and compute the velocity and height of the cloud feature. It should be able to use a cursor to draw around a feature and extract the digital data inside the outline. This digital data could then be used to extract information such as area of the cloud, growth rate of the area, etc. The ability to image process entire images would be desirable for research studies (but are not expected to be used operationally at first). Image processing capabilities desired for a single image would be the ability to detect and remove bad lines, to form an equal occurrence of brightness values auto enhancements, to perform a high pass filter, to perform a low pass filter, to perform a shot noise filter, to perform a digital stretch, to perform a gradient operator, to add, subtract, multiply, or divide the data by a constant, to perform an interpolated blow-up of the data, and to average the data down for blow-downs. Other standard image processing capabilities such as fast fourier transforms, etc., would be acceptable for the National Center Upgrade System, but are not currently used at the NSSFC. Desired image processing capabilities for multiple images would include averaging of images, minimum brightness composites, maximum brightness composites, weighted linear combination of images, cloud threshold composites (clouds only excluding the ground), addition, subtraction, multiplication and division of images, and mosaicing of images. The functional combination of images and gridded data would also be desired, such as the ability to display infrared data whose gray scales are relative to the tropopause temperature (or equilibrium temperature) at any given location.

Another image processing capability required would be a remapping capability. The system should support the remapping of various data into the projection of other data. While the satellite data will frequently be the base projection of the display because of its high data volume, the ability to remap the satellite data into other projections is still required. The ability to remap the satellite into the projection of another satellite, a polar stereographic

projection, a mercator, a Lambert conformal projection and a radar projection is required. The ability to rotate an image would be desirable for research purposes. When an image has been remapped (or any other geometric transformation has been done) the system needs to keep track of the transformation so that overlays of other data would still be possible.

In addition to processing visible, infrared images, the National Center Upgrade System will also have to perform the functions of the VAS Data Utilization Center (VDUC) system. The exact VDUC requirements for the NSSFC are still being developed with the following being projected VAS processing requirements. The system will have ingest and distribute the VAS imagery to all forecast stations requiring VAS data. In addition the system should be able to compute composite images based on various sounding bands, such as a low level moisture image and a composite stability image. The system should be able to compute a limited number of sounding retrievals and associated products (with the main retrieval tasks being done routinely at NMC). The system needs to be able to access the routinely processed NMC VAS retrievals and use them as sounding data as was discussed in section V.A.6 and V.C.5 and 6.

V.C.9. Radar Data Processing

Radar data process is very similar to satellite image processing. The ability to request specific radar ingests, loops of the radar, composites of several radars, radar images in satellite projections, and tracking of radar features is required. In addition, the ability to highlight by flashing or similar means specific radar reflectivities would be required. The ability to overlay other data sources, grids, etc., on the radar loops is required in the same fashion as the satellite data.

V.C.10. Aviation Data Processing

In addition to the normal ingest, listing, plotting, etc., of aviation related observations, several special processing capabilities are required for the aviation forecasting groups at the NSSFC. In addition to plots of forecast products derived from NMC such as NGM gridded displays and FOUS displays, the system should also support terminal forecast displays as a function of both space and time. Because terminal forecasts are manually developed, they frequently contain hedging (such as a forecast for partly cloudy with a chance of thunderstorms). The system should be able to show plots of the forecast data and also to display the hedging information if desired.

The system should support an algorithm for determining icing potential, such as the algorithm developed by the U.S. Air Force. It should have an algorithm for objectively determining mountain wave turbulence threat areas, capability for plotting a nephanalysis of instrument flight rules (IFR) areas caused by low clouds, an analysis of ceiling height above ground and above sea level, an algorithm for determining areas affected by turbulence caused by winds interacting with terrain, an algorithm for determining areas affected by clear air turbulence, etc. It should be able to support displays of forecast winds, temperatures, dew points, and ceiling heights.

V.C.11. Numeric Guidance Processing

It is anticipated that the system will have gridded numeric guidance products which can be used for custom displays and further diagnostic processing. The ability to produce displays of derived products (such as streamlines, etc) produced by manipulating objectively analyzed observational data as described in section V.C.6, should also be available for gridded forecast data, as should the ability to produce contoured displays. In addition to these capabilities, the ability to further process forecast data is necessary. One product would be an hourly lifted index produced from observed surface data and forecast 500 mb temperature grids as is currently being done for the SELS unit. Another processing product would be the interpolation of 6-hourly forecast fields to any given time. This would allow forecasters to ask "what is the state of the atmosphere right now" as well as for some specific forecast time in the future. Another product desired would be indicators of how well the model has been doing recently. This would take the form of difference fields between forecasts and recent observations, and phase speed errors determined by bandpass analysis of forecast and observed fields with a correlation analysis to determine errors in the speed of propagation of forecast features.

V.C.12. Verification Processing

The NSSFC currently collects and verifies all severe storm and tornado watches and warnings in the United States. Weekly status and monthly verification statistics for each Weather Service Forecast Office are generated by the NSSFC/TDU and sent to the appropriate offices. Currently the data collection and data entry is semi-manual. The computer will look for appropriate message header information and send the messages to a printer. The verification

specialist codes the information, puts it into appropriate files, and then runs various programs for the generation of verification statistics. The severe storm event files then become the basis for severe storm climatologies. The verification program at the NSSFC will probably be expanded to include winter storms, flash flood and high wind events. It is also anticipated that the data collection and data entry functions will be made more automated in the future. The National Center Upgrade will have to support the verification programs by allowing the automatic collection of appropriate data, data entry, manual quality control, background processing of the statistics, and dissemination of results over AFOS/AWIPS-90 and printer output for mailing.

V.C.13. Lightning

It is anticipated that lightning location data will be available within the lifetime of the National Centers Upgrade System. Beyond ingest and filing of the lightning data, the required processing includes displaying stroke location as overlays for other data with color being used to designate timeliness. The ability to outline a cloud or a region, derive statistics on number of strokes as a function of time, and derive statistics on the time rate of change of strokes would be required. Other processing routines will probably be developed as lightning research progresses.

V.D. Workstation Requirements

The interactive workstation forms the main focus point of the National Center Upgrade System. Here the forecaster controls all the processing of tasks pertinent to his forecasting duties, receives all the necessary information required for the generation of his forecast, and does all of the forecast product generation. The workstation combines all of the capabilities of the current AFOS, CSIS, Eclipse AOS, and EAS workstations.

V.D.1. Workstation Functions

The forecaster workstation should consist of a command and control module, an alphanumeric display module, a high resolution graphic display module, an image display with graphic overlay module, and an extended looping image display module. A workstation is required for each forecaster on duty as well as a research and development facility. The actual characteristics of each work station (such as the number of image frames, etc.) will vary according to the needs of the different units. A total of thirteen workstations are required initially although the

sys- tem should be expandable to at least 20 workstations to accomodate any future expansion as described in section IV.C.1. The initial twelve workstations would be used as follows with type A terminals having more frame space than type B terminals.

| | <u>Number</u> | <u>Type Terminal</u> |
|----------------------|---------------|----------------------|
| SELS lead forecaster | 1 | A |
| SELS assistant | 2 | B |
| SFSS | 2 | A |
| Convective SIGMET | 1 | A |
| FA | 3 | A |
| NPSU | 1 | B |
| TDU | 1 | B |
| SFSS R&D | 1 | B |
| Maintenance | 1 | B |
| | 13 | 7A and 6B |

V.D.2. Workstation Command and Control Module

The man-computer interface forms a critical node in the successful deployment of the National Center Upgrade System. The specification of the interface is difficult because of the rapidly changing technology in this field. Traditional interfaces have used a CRT keyboard with either a menu or command language for system control. Menus have the advantage of ease of learning by offering visual cues. They have the disadvantage of lack of flexibility and slow responsiveness for experienced users. Command languages have the advantage of rapid, flexible control but suffer from difficulties in learning the language and poor retention of seldom used commands. The man-computer interface required of the National Center Upgrade should combine the advantages of both menus and command language without any of the disadvantages of either. The perfect interface does not yet exist, but the several systems have prototype interfaces which show promise. The data tablet of CSIS allows the forecaster to easily chain together a command is an example of a way to use a visual control device to a command language. While the CSIS data tablet can support many different command configurations it, by itself, is not adequate for an operational system. A means of having the computer write the command set-up on the data tablet would be required. The command interface at PROFS likewise is a good example of having a flexible visual control device overlaying a menu-driven system. Commercial examples of this type of control are demonstrated by the Apple Lisa system and other new business oriented systems.

The National Center Upgrade system designer should try to develop a user interface which is fast, flexible, and easy to use. A computer written command display which has a large number of options for system control would be suggested.

Whatever the eventual design of the user interface, it must have certain devices and functions. A keyboard will be needed for message text generation and could be used for system control functions also. The interface must allow the chaining of commands into functional tasks which can be executed with a single command. The system must allow for at least 100 of these user defined functional commands for each terminal in addition to general command and control functions common to all workstations. The interface also must support position dependent controls of cursors on all the different displays. These controls will be used for pointing to specific locations on the display and also for contouring graphics. A combination of interactive control devices could be used for different control functions as long as the system was still easy and efficient to use.

The man-computer interface must be sophisticated enough to allow the computer to alert the forecaster to obvious human errors made in entering commands and errors which occur during system procedures. Also, there must be an operator selectable mechanism by which the system alerts the user to such items as the receipt of significant information, impending deadlines and any requirement of further input.

The system requires a scheduler which can initiate procedures at defined times and automatically recover from most error conditions. The scheduler should start requested procedures within a specified time window. It must be able to handle multiple requests for different procedures within requested overlapping time windows. The scheduler should be able to start either interactive or batch type commands.

The system should allow one program to initiate another program. Many control decisions are based on data dependent factors. If a satellite starts transmitting data, then the appropriate ingest program should be started. Likewise, when a given amount of conventional data has been ingested, then a decode program should be started.

V.D.3. Alphanumeric Display Module

The alphanumeric CRT and associated keyboard must have a 132 columns by at least 48 lines of display. A four

"window" splitscreen capability with a simple copy capability to transfer portions of text from window to window is required. It must have a scrolling (up and down) display capability for each window. The keyboard must have the standard typewriter keys, cursor control keys, unique AFOS character keys, tab keys which can be set via the computer for message composition and special purpose keys which can be defined for meteorologically or image processing unique commands. It must set up for rapid word processing control as discussed in section V.B.1.

V.D.4. High Resolution Graphic Display Module

A high resolution (1,000 lines or better) display is needed for graphic and alphanumeric displays. The device should display at least three graphic fields plus a map background simultaneously. The graphic fields should be able to be displayed and removed independently of one another. The removal of one must not affect the remaining fields. The graphics must be color coded, with the colors under operator control to accommodate color blind people who may require different color combinations than other users. Solid, dashed and dotted lines for contours must be possible. Operator assigned lengths for dashes and dash gaps is also a desired feature. The capability to rapidly change between types of lines and to cause them to fade is required. Labels on graphics must be standardized and located such that they do not interfere with each other when fields are superposed.

It must be possible to loop through graphic products. Considering a single graphic display as a single frame, at least 24 frames of graphics are required for the loop. Simultaneous looping through three different graphics with a constant background must be possible. The looping should be selectable to be either under manual or computer control for the stepping between frames. Loop speed will be hardware controllable and vary between five displays per second and one display every ten seconds. Flyback or reverse animation is to be the user's option. While only 24 graphic frames would be available for immediate use, capability to store a larger number of graphic products on the computer should be provided. The system should be able to store up to 2000 graphic products per terminal.

The display must have zoom and translation functions. Additionally, it must also be available for use as an auxiliary CRT display. When used in this mode, it will have the same basic features of the CRT previously described. The main and auxiliary CRT functions should be independent so

that two messages can be displayed and worked on simultaneously.

V.D.5. Image Display Device

Image data from satellites and associated graphic overlays are needed. The image must have 256 gray shades (eight bit display). A medium resolution display of 480 lines or better is required. A minimum of 48 frames is required with 64 to 96 frames being highly desirable for type A workstations. A minimum of 24 frames is required for a type B workstation with 48 to 64 frames being highly desirable.

Looping must be under both manual and computer control. Automated loop speed should be operator controllable with a maximum loop rate of five frames per second for the entire frame space and up to fifteen frames per second for a loop of up to six frames. The user must be able to vary the loop bounds, rate and mode of transition. The system should allow the loop to dwell on the most recent image and have either flyback or reverse animation.

A large amount of meteorological image data is "paired" such as the visible and infrared data from the geostationary satellites. The terminal must, therefore, allow instant transfer between paired images.

A capability to perform a pixel-replication "zoom" on the contents of any frame or sequence of frames is required. This should be an instantaneous capability centered over a cursor designated location at 2 and 4 times resolution. The intent is not to display more information; rather it is desired to "enlarge" or "blow-up" what is currently displayed on the frame.

The system must have a graphic capability of the same resolution as the image. The graphic must be able to be superposed over images with noninterference of labels. It must be a nondestructive overlay which can be superimposed or removed without affecting the underlying image. Four separate graphics (three graphic products plus a map background) are required to overlay a given image frame. The interaction of the graphics should be nondestructive. The graphics should be able to be color coded according to the desires of the individual user. The graphic color should have a higher precedence than the underlying image.

While a maximum of four individual graphics are to be shown at any given instant, the system should have the capa-

bility of looping graphic overlays either along with or separately from the underlying image.

The system should allow false coloring of the data. Each of the image's 256 gray shades should be able to be colored differently. The false coloring system should also allow black and white enhancements of the image. Separate loops of data on the system should have separate false coloring and enhancements available so that when loop bounds are changed, the enhancements will automatically change. Up to eight loops of images and associated enhancements are desired. The graphic colors should also be under the control of the individual user.

In addition to false coloring of a single image loop, the system must support the functional combination of images with false colors. An example would be to have the infrared image loop tint the visible loop according to the temperature of the clouds in the infrared images.

The normal false color configuration is an input of two eight bit images and an output display of three color channels. However, it is desirable to have this basic 16 bit enhancement system available for nonstandard configurations using functional combination of several images and graphics. Finally, the ability to animate these functional combinations must exist.

V.D.6. Extended Looping Display

An extended looping capability is required for the purposes of presenting background information on large-scale atmospheric processes. This information is required at all the workstations and as such can be a shared resource. This essentially takes over the function of the present EAS system. There is a requirement to display loops of one day's worth of half hour satellite images. Hence at least 48 images in a loop are required. Since a satellite puts out two simultaneous channels (visible and infrared) each loop of 48 images needs to have an "opposite" loop of images of the other channel with instant transfer between the two loops. A pair of working loops for each satellite is required. In addition, loops of water vapor from each satellite (one image/hr) should be supported with 24 images in each loop.

Along with the extended loop, there must be false color capabilities which access the full bit range of the infrared data. There needs to be a graphic overlay of geographic and state boundaries. There should be instant transfer between

the opposite loops. In addition, there should be a capability for the functional combination of paired loops. This should include coloring the visible according to the temperature of the infrared image. A capability to juxtapose any two of the six working loops side by side should also exist.

Looping rate must be hardware controllable (5 frames per second maximum). Transition from the end of a loop to its beginning must be either instantaneous (flyback) or by reverse animation at the meteorologist's option.

The basic display of the extended loops should be on a TV standard RGB image of 480 lines or better. At each workstation, the forecasters should have the ability to switch to any of the working loops, to zoom, start, stop, change loop end points, change transition mode or step through the loop. Operations on one loop should not impact any other. A master control station should not only have the capability to do these functions but also be capable of loading backup loops, creating enhancements, etc. The master control station can override the commands of the workstation loop monitors. There must be communications between the workstations and the master control station.

V.D.7. Map Plots

There is a requirement for the generation of paper maps with computer plotted station models and contours. These paper plots should be able to be hand contoured (only station model plotted including wind direction and speed symbols) or be machine contoured. The paper must be such that it can be drawn on with colored pencils or pens. Erasing should not destroy the computer drawn information. It would be desirable for the plotter to have capability for different colors, for different parameters in the station model or different contours. The map background must be variable between plots without the need for constant operator intervention. Up to six different map backgrounds should be supported at a time.

V.D.8. Printers

There is a requirement for low-noise printers of approximately 100 lines per minute in the immediate work area of each CRT terminal. These slow printers are for hard copy alphanumeric output of data and information. One printer is required for each of the six work areas. Additionally, there is a requirement for one central printer facility for large file outputs. Two printers of 300 lines per minute or one printer of 600 lines per minute or faster

would meet the needs for program files, data files, archive print files, etc.

V.D.9. Image and Graphic Copies

There is a need to document and display various image and graphic products from the video monitors. Such hard copy outputs should be approximately 8" x 10" or larger. The hard copy can be black and white with colors being converted to gray shades. A true color copy capability is highly desirable but not required. The copy must be able to be written on and erased with colored pencils without destroying the original imager with the erasures. The copy's lifetime should be several days or longer. Each of the graphics/video monitors must be accessible to the hard copy device. The use of the hard copy device should not disrupt the use of the monitor for more than ten seconds.

In addition, there is a requirement for a high quality color photographic copy capability. These copies would primarily be used for publication purposes. These copies should be either 35 mm slides or color prints of 4" x 5" or larger. Also, there is a requirement for video copies (either tape or disk) from the video monitors. These copies would be used for training and documentation. The video copy capability requires the original recording function, a playback function, and an edit function. The ability to do simplex studio editing functions of fades, insets, single frame edits, etc., is desired. There is a need for only one of each of these units which can be assessed by any workstation.

V.D.10. Ergonomic Requirements

The workstations should be designed with human factors carefully considered. Control devices, monitors, table space for map analysis and telephone set must all be within an arm's length.

The workstations must be designed to reduce visual and physical fatigue. The lettering on the CRT displays should be large enough that they can be easily read without eye strain. Flicker, jitter and/or shimmer of the monitors must be minimized. Thirty Hz flicker of the presentations cannot be tolerated. The terminals should be designed for use in lighting compatible with an office environment where documents are routinely read. Means should be available for controlling glare problems.

The work space design should be considerate of differences in heights and body builds by allowing variations in chair and keyboard height adjustments. Sufficient table space should also be available for documents, charts, etc., to be layed out and worked on in the terminal area. Noise due to cooling fans, etc., should be kept to a very low level. The work stations must be able to stand the shock of operators rolling about on chairs bumping into them inadvertently.

V.E. System Utilization

While a system such as the National Center Upgrade can do almost anything, it does not do everything all the time. The following is an estimate of the anticipated hourly work load of the system for current tasks. As mentioned in section IV.C.1, the current forecast responsibility may grow by a factor of 50% during the lifetime of the system. Likewise, the system should have some growth capability to accommodate normal growth of desires for system capabilities. (Past experience has been that within a year after any system installation, all the computing resources have been used and the demand exists for still more.) A total growth factor of 100% should be anticipated over the lifetime of the system.

V.E.1. Conventional Data Utilization

Every hour, an objective analysis of the United States at 50 km resolution is required for the temperature, dew point, pressure, altimeter change, u component of the wind, and v component of the wind, mixing ratio, and equivalent potential temperature. From these basic grids contoured displays should be computed for all of the working loops at each terminal. Each loop defines an area, resolution, and projection of interest. Type A terminals will have up to eight loops. Assuming three pairs of loops, then there will be five different basic projections. Type B terminals will have up to four loops of which one will probably be paired leaving three basic projections. For each loop, the forecaster should be able to have precomputed displays of temperature, dew point, pressure, streamlines, isotachs, altimeter change, and up to four other contoured fields derived from the same basic gridded fields. A total of 10 displays for five loops, for seven type A terminals and three loops for four type B terminals for a total of 470 precomputed contoured fields per hour should be available. These precomputed contoured fields would be available for rapid loading onto the graphics overlay. The basic objective analyses of the base data should be completed within five minutes after receipt of data. The six displays for

each loop of temperature, dew point, pressure, streamlines, isotachs, and altimeter change should be available within 10 minutes after receipt of data and all ten fields should be available within 15 minutes after receipt of data.

In addition to precomputed displays of contoured surface data, the system should support station plots of temperature, dew point, pressure, wind speed and direction, and altimeter change. These station plots should be available for either hand analysis or overlaying on the contoured graphics. The station displays should be available at each of the seven type A terminals either as a graphic or hard copy within 10 minutes after receipt of data.

The system should also support listing of observations at any time. Approximately 10 requests per hour per terminal for a total of 110 could be expected per hour. Listing operations should be completed within 30 seconds of each request.

The system should also be able to support "non-standard" requests of data analysis and displays which are not precomputed. Approximately four per hour per terminal could be expected for a total of 44 per hour. These displays should be available within two minutes after the request.

Upper air data is available every 12 hours. Contoured fields should be routinely available at the 850, 700, 500, 250, and tropopause levels. Fields of streamlines, isotachs, temperature, dew point, heights, height changes, wind direction change and temperature advection should be made available on a U.S. scale display for all the workstation graphics within 15 minutes after receipt of data. Station plots of the observations and change of observations should be available at the same time. Fields derived from radiosonde data, such as stability parameters, should also be available within 15 minutes after receipt of data. Any of the basic upper air data should be able to be plotted or contoured on top of any loop of satellite or radar within 30 seconds of the request. Requests for non-standard upper air displays requiring grid manipulation (such as band pass, etc.) and contouring should be supported. These displays should be available within two minutes after the request. Four per terminal per hour could be expected for a total of 44 per hour. Requests for displays in other coordinate systems, such as sigma or isentropic, should be supported if requested. Contoured fields, etc., appropriate for that coordinate system should be available within fifteen minutes of the request. A request for this other coordinate system could be expected from one workstation every 12 hour period.

It can be assumed that this request would not overlap the time required for processing the upper air data in pressure coordinates.

Plots of single station data, such as a skew-T/log P or Stuve diagram should be completed within 30 seconds of a request. Approximately 3 request/hr/workstation is anticipated for a total of 33/hr. Cross sections should be completed within two minutes of a request. Two per hour from three terminals can be expected for a total of six cross section/hr.

V.E.2. Satellite Data Utilization

Up to date loops of satellite imagery form the backbone of most of the NSSFC operations. During severe weather situations, fifteen minute satellite imagery is routinely available. Of the eight loops on the type A terminal, seven will probably be satellite imagery and one radar. The radar will also probably be updating at a fifteen minute cycle. The four loops on the type B terminals will probably be mainly satellite imagery. Hence, within each 15 minute period, 8 loops on 7 type A and 4 loops on four type B loops for a total of 72 TV frame loads (288 per hour) can be expected. However, because of the demand for timeliness in satellite displays, the system should be able to load seven loops on seven type A and four loops on four type B terminals for a total of 65 TV frames) within three minutes after receipt of data. In addition to loading the workstation loops, the system must also load the extended looping device every 30 minutes for four loops and every hour for two more (for a grand total of 298 loads/hour). Also, the system should support rebuilding of loops in a new region from data stored on the system disks. A loop of six images should be able to be reloaded within two minutes after the request.

VAS processing will consist of both image display functions and computational intensive retrieval tasks. The VAS image display utilization tasks are contained in the previous paragraphs. The anticipated retrieval tasks would be the generation of up to 100 sounding retrievals within 10 minutes of request. It can be assumed that one terminal per hour would require VAS processing capabilities. Display of VAS products generated at NMC would be similar to the display of radiosonde data discussed in section V.F.1. It can be assumed that VAS data displays would take place during hours when radiosonde data is not being processed.

In addition to VAS data processing, quantitative processing of satellite imagery such as cloud growth, cloud displacement, image manipulation, etc., is anticipated. It can be assumed that half the terminals (5) will request some type image processing program each hour.

V.E.3. Radar Data Utilization

Radar from six radar sites ingested every 15 minutes is specified in section V.A.3, of input data, with an anticipated expansion to 12 radar sites during the lifetime of the system. The radars should be able to be displayed in a loop or composited. The display requirements are included in the previous satellite section. The remapping and compositing would be for either two or three radars. It can be assumed that six remaps and three composites will be required every 15 minutes. (The remaps will probably be into the satellite projection.) The time required for the two remaps and one composite should be three minutes or less. All of the radar data received in each 15 minute period should be processed within the 15 minute period (including the anticipated expansion to 12 radar sites).

In addition to radar image data manually digitized radar (MDR) displays including reflectivity levels, heights and motion of cells should be generated from coded observations. The MDR data is taken every hour on the half hour. The national display of MDR data must be completed within 10 minutes of the beginning of data reception (or 2 minutes after the end of data reception).

NEXRAD products will include computer processed products as well as imagery. It is anticipated that the NEXRAD imagery utilization would be covered by the previously stated radar imagery requirements. In addition, NEXRAD processed products should be used as graphic overlay displays. A total of three graphics per radar site per 15 minutes (total of 18-36 graphics/15 min) can be expected.

V.E.4. Forecast Data Utilization

Currently, approximately 120 AFOS forecast displays and 200 grids of LFM forecasts are received at the NSSFC. The gridded products can be expected to expand to 600 or more in coming years. The system needs to support the contoured display of gridded data. Any given display of gridded data should be completed in 30 seconds or less. Each workstation can be expected to request 15 fields per hour for a total of 165 contouring request per hour. In

addition, derived products such as vorticity advection which require grid manipulation can be expected. Approximately 4 requests per terminal per hour can be expected for a total of 44 grid processing and display operations.

V.E.5. Diagnostic Model Utilization

In addition to displays of observations and forecast fields, the NSSFC operations require the utilization of special diagnostic models. An icing potential model, a mountain wave model, a clear air turbulence potential model, and a low level terrain induced turbulence model are routinely used at the NSSFC. Simple numeric models such as a one dimensional thunderstorm model and a two dimensional advection model are also currently used. The use of diagnostic models can be anticipated to increase in coming years. It can be anticipated that half the terminals (5) will request the running of some diagnostic model during each hour.

V.E.6. Forecast Product Preparation

The various units have forecast products described in section II.B, which require word processing capabilities described in section V.B.1. All workstations should be able to simultaneously generate messages without interference with one another. However, for sizing purposes, it can be assumed that only three workstations will be generating messages during any given time.

V.E.7. Research and Development Utilization

The National Center Upgrade system is anticipated to be a dynamically growing system throughout its lifetime. It must support both meteorological research and program development in addition to the normal forecasting workload. The meteorological research workstation display requirements have been included in the work loading specifications of the previous sections. However, the data base of images, observations, and grids will be for a different time period than the current forecast operations. Two of the workstations (TDU and SFSS research) could be processing historic data. The system needs to support at least one historic data set per research workstation (two for the entire system).

Program development and system support activities will require interactive CRT terminals and the ability to do system development activities concurrent with system operations. A total of 19 programming type terminals are required for the following groups:

| | | | |
|--------------|---|--------------------|---|
| TDU | 5 | Computer Operators | 1 |
| Verification | 2 | SFSS Research | 1 |
| EDP | 2 | Administration | 2 |
| Maintenance | 2 | Forecast Units | 4 |

The system should be able to support an average of six people working simultaneously on program development, each with an average of four Fortran compiles, links, and loads per hour for a system total of 24 per hour.

The system also must be available for general computational work loads, such as verification, general scientific development activities, administrative functions, etc. A total throughput of approximately 10 jobs per hour can be expected.

VI. System Support

The system must be maintainable and capable of future expansion. It must be able to maintain 24 hr/day, 365 day/year operations. It must be developed so that a dedicated staff of professional electronic technicians, computer operators, and programmers can operate, maintain, and expand the system.

VI.A. Software Development Aids

Because of the changing environment throughout its lifetime, the system must supply software development aids such as programming compilers, macro expansion capabilities, editors, a source level debugger, and documentation routines.

VI.A.1. Programming

The system must support popular compiler languages including at least Fortran, at least one other high order scientific programming language, and Assembly Language. Utility programs such as data access subroutines must be available to programs written in all the high level languages. The compilers must have informative error messages which aid in the debugging of programs. They must be available either from foreground or background devices such as interactive image terminals, interactive non-image CRTs, a card reader, and tape drives.

VI.A.2. Higher Order Command Procedures

The interactive command procedures discussed earlier will allow a user to initiate applications programs. However, there needs to be a means of stringing modular applications programs into procedures. Higher order command procedures are needed in order to build macros of the command controls. This macro facility should be simple but effective. It must include standard programming features such as arithmetic and logic operations, program jumps, and decision constructs. The macro control logic should be able to be controlled by outputs of commands within the macro.

VI.A.3. Interactive Editors

The system must support interactive programming via a CRT editor. This interactive programming capability must include the standard features of an advanced interactive editing system. These editors must be user friendly since many of the programmers will be meteorologists, not computer specialists. The system should support a source management system.

VI.A.4. Utilities

The system must support program development. It must contain libraries of utilities which can be used as parts of new programs. These libraries must include standard scientific, mathematical, image processing, word processing and statistical support functions in addition to system specific functions for data access and manipulation.

VI.A.5. Processing on Remote Computers

The Central Computer Facility in FB4 must be accessible from this system. The system must allow Remote Job Entry (RJE) access to the NMC Central Computing Facility to start production run programs, for remote data access, and for programs (such as models), which require the use of a larger computer. Also, medium to high speed computer to computer data transfers between the Central Computer Facility and the NSSFC system must be possible.

VI.A.6. Software Documentation

The software must be maintainable and expandable by in-house programmers. The software should be carefully designed and be highly modular in nature. The interfaces between modules should be easily identifiable and well documented. The system documentation should have a clear overview of the software system including the control logic, flow of processing, data base management philosophy,

libraries available for use, etc. Every program and sub-routine should be documented with comment cards to include input data, output data, what general processing has been done to the input data to get the output data, and any transfer of control other than a return to the calling program. Sufficient comment cards should be used throughout the program such that an experienced programmer can follow the flow of logic in the program. Common blocks should be documented as to what other programs use the common block. All file structures and protocols should be carefully documented.

In addition to the general system overview and the individual program documentation, a directory of all software with a brief description of every software module should be provided. A means to search the directory for software program names or for program functions should be provided.

All of the documentation must be in a form such that it can be updated as changes are made to the system. Paper listings in binders of the software should be provided in addition to the disk based source management system.

The computer operating systems should be supported by the computer vendors throughout the lifetime of the system.

Any firmware developed for system should also be documented to the same level of detail as the software written in assembly language. Listing of the firmware code should be included as part of hardware documentation.

VI.B. Hardware Maintenance

The system must be able to be maintained by technicians other than the original designers of the system. A complete set of spares must be provided for all the hardware not supported by vendor maintenance agreements. At least one of every board, module, etc., should be available such that a failure occurs, the failed equipment can be unplugged and a good module plugged in. The time to get the system back in operation should be one half hour or less. A maintenance facility should also be provided such that the failed module can be brought back to the maintenance facility and fixed as time permits. The maintenance facility should be provided with sufficient stock of components to maintain the system over a projected ten year lifetime. The maintenance facility should have sufficient test equipment (or specifications for required test equipment) for all aspects of system maintenance.

Thorough operations and maintenance manuals should be provided. Manuals on the general system overview, module specific theory of operations, trouble shooting aids, etc., are required. Complete schematics, layout charts, and cabling diagrams are required. All OEM vendor manuals available for components of the system should be provided.

VI.C. Training

Comprehensive training courses for hardware maintenance, software maintenance, computer operations, and forecaster users should be provided. A means of training new personnel throughout the lifetime of the system should be provided.

VII. System Reliability

Because of the critical nature of the mission of the NSSFC, the system must be able to operate 24 hours/day, 365 days/year. Total failure of the system would be catastrophic. The system should have fail-soft characteristics so that it can continue to operate, albeit in a degraded mode, rather than failing completely. There should be no potential single point failures in the system which could bring the entire system down.

While the system should be designed for very high overall availability, fail-soft failure modes can be tolerated for short periods. A loss of up to one half the terminals and one half the computing processing could be tolerated for up to eight hours if all data input and output functions were maintained. The loss of any one data input could be tolerated up to eight hours if a complimentary data source were available (such as the loss of one satellite ingestor if the other satellite ingestor were still available). Highly critical data such as conventional surface and upper air data should be available from two complimentary data sources (one NWS and the other FAA).

FIGURE 1
 NSSFC Eclipse S/230

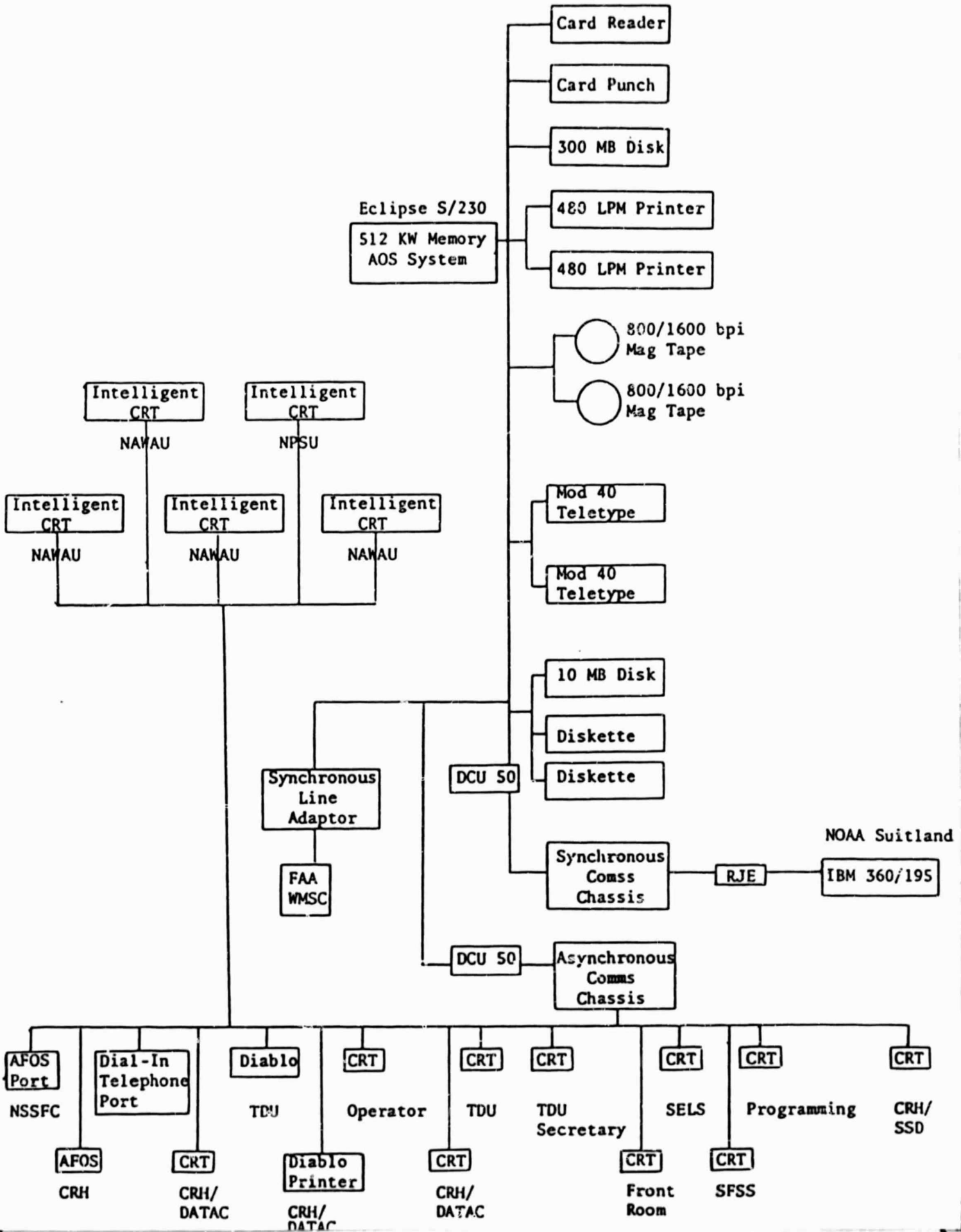

FIGURE 2
NSSFC AFOS Systems

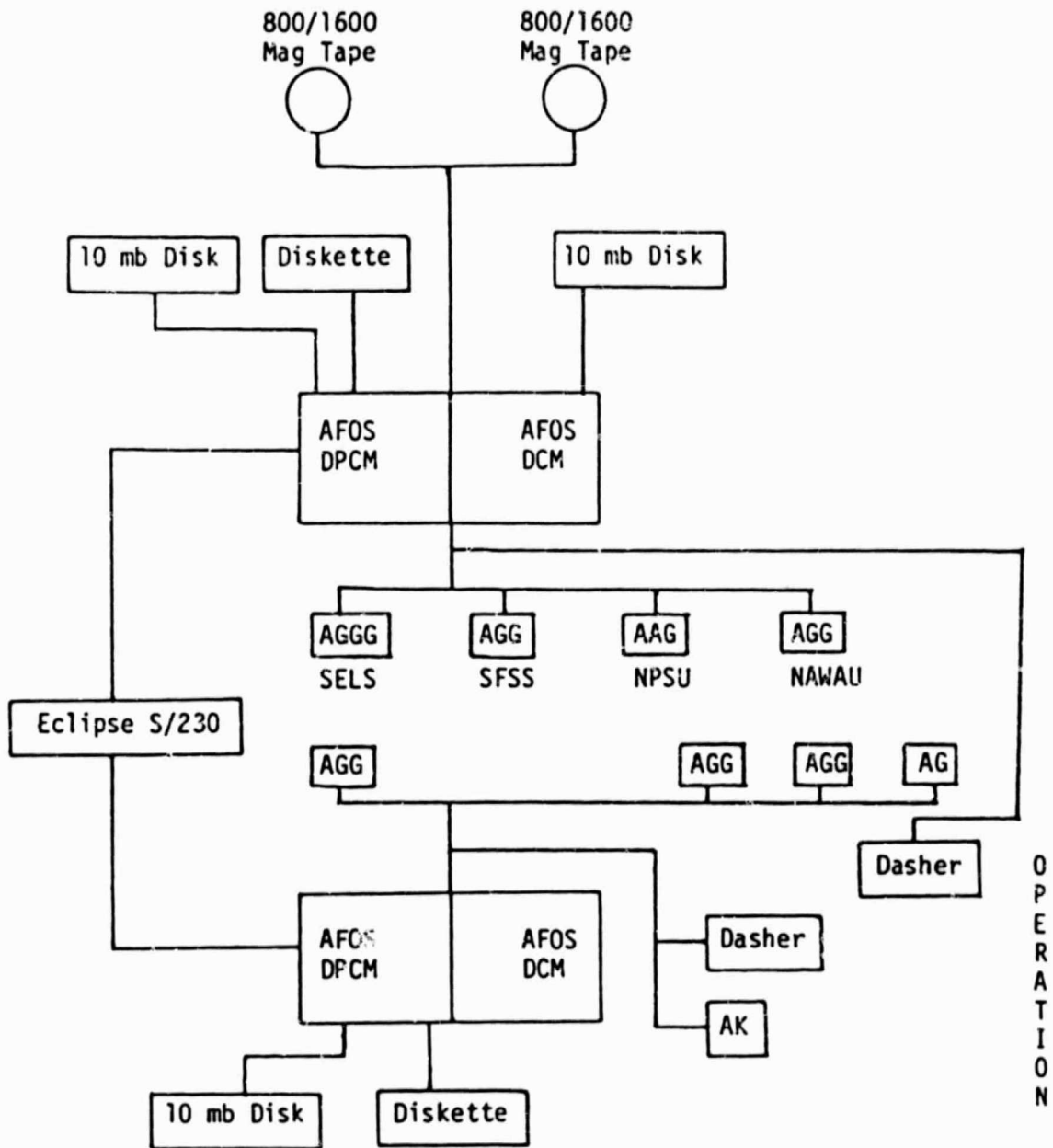

FIGURE 3
CRH AFOS SYSTEM

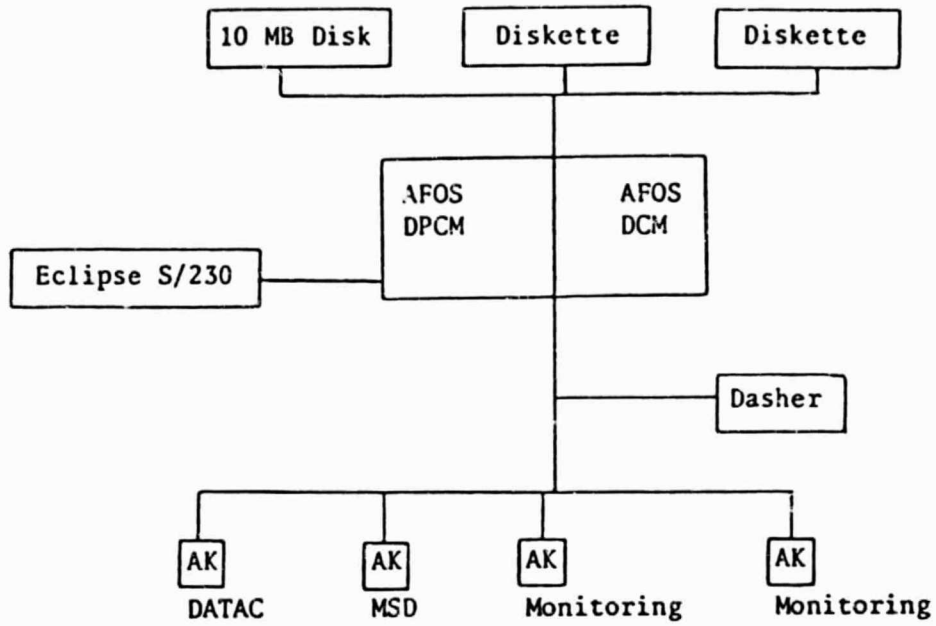

FIGURE 4
EAS SYSTEM

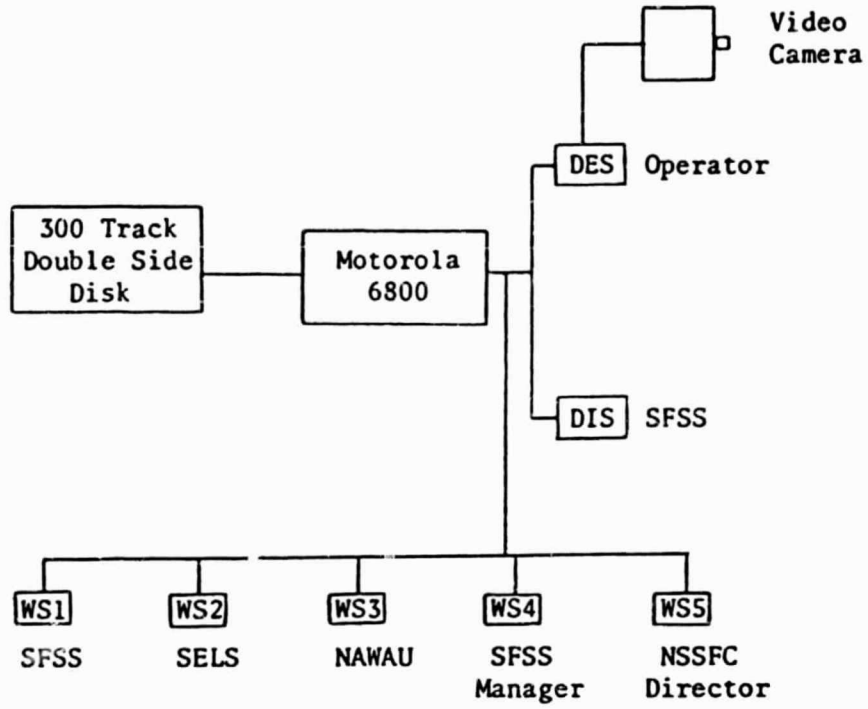

FIGURE 5
 CSIS FULL CONFIGURATION

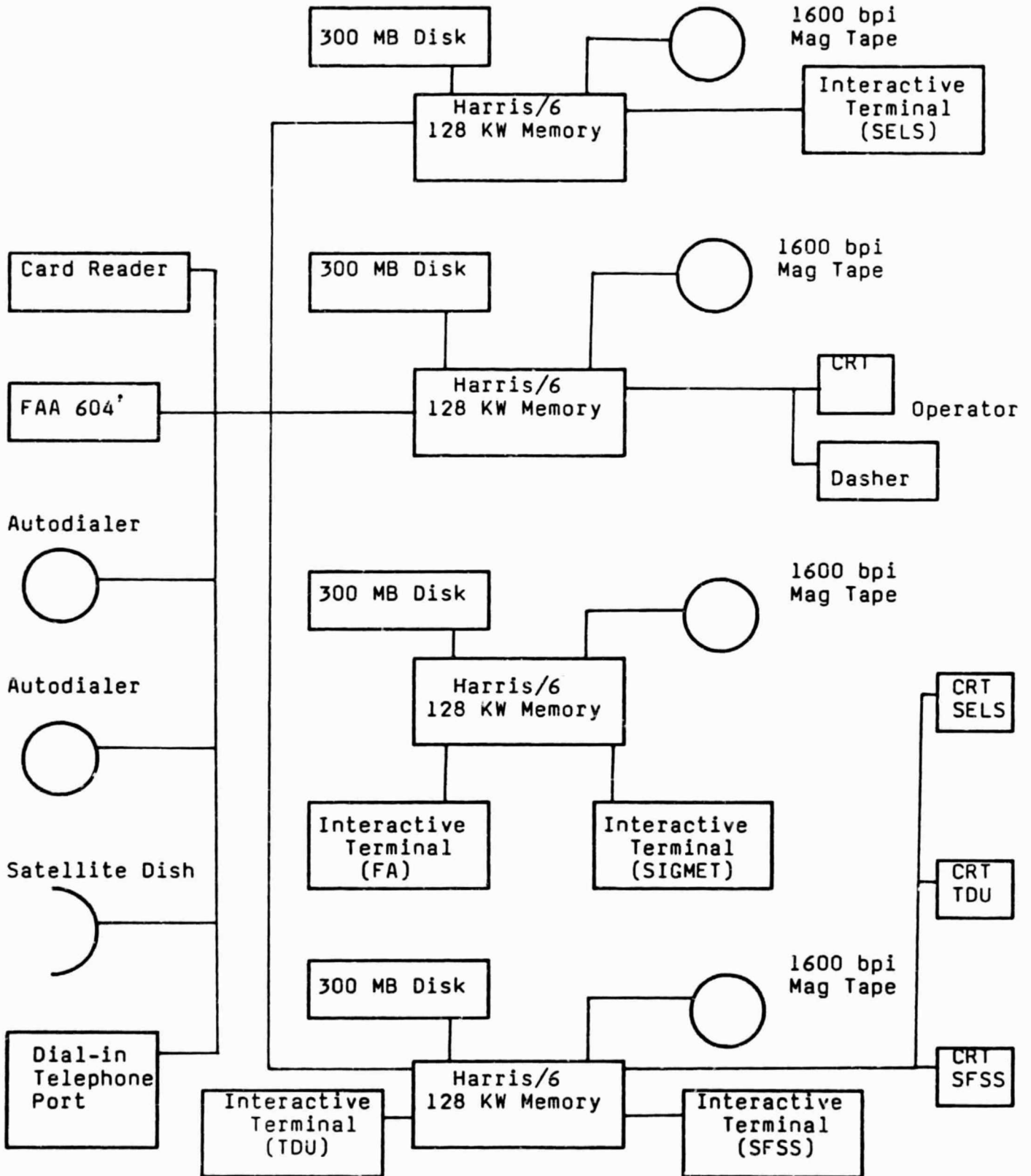

TABLE 1
National Center Upgrade Input Data

| <u>Data Source</u> | <u>Data Collected</u> | <u>Current Data Rate (bits/sec)</u> | <u>Future Data Rate</u> | <u>Data Protocol</u> | <u>Data Storage Volume (Megabytes) (Initial) / (projected)</u> | <u>Current Status</u> |
|------------------------------------------------|-------------------------------------------------------------|-------------------------------------|----------------------------------|----------------------|----------------------------------------------------------------|-------------------------------------------|
| FAA WMSC | Surface Observations, Upper Air Observations, Pilot Reports | 2400 | 9600? | FAA developed | 2.5 / 5.0 | on AOS; on CSIS (through FAA 604 circuit) |
| GOES-East; GOES-West | Satellite Images | 1.8 x 10 ⁶ (Mode A) | 2.2 x 10 ⁶ (Mode AAA) | Binary data stream | 1311 / 2167 operations + 184 / 368 research | GOES-East received on CSIS in Mode A |
| Dial up Radar (RRWDS (2-4 phone lines needed)) | Radar Images | 2400 | 4800 (NEXRAD) | SDLC | 1.8 / 3.6 | Kavours/RADID Currently used |
| AFOS/AWIPS-90 | Observations graphics MDR | 2400 | ? | ADCCP/Async | 18.1 / ? | AFOS displays used |
| NMC | Forecast grids, display grids, VAS data | 9600 | ? | Bisync | 14 / ? | RJE link |
| Lightning via phone line | Lightning location | 1200 | ? | Async | 1 / ? | Experiment on CSIS |
| | | | | | 1532.4 Total | 2544+ |

TABLE 2
AUXILIARY TABLES

| CLOUD COVER | | | |
|---------------------------------------|----------------------------------|----------------------------|-----------------------|
| COVERAGE | REMARKS PERTAINING TO BASES | REMARKS PERTAINING TO TOPS | OBSCURATION PHENOMENA |
| Scattered | Mountain Ridges Obscured | Merging layers | Fog |
| Scattered-broken | Mountain Passes Obscured | Multiple layers | Haze |
| Broken | Mountain Tops Obscured | | Dust |
| Broken-Overcast | Lower Clouds Coastal Regions | | Smoke |
| Overcast | Lower Coastal Stratus | | Sand |
| Partial-obscuraton | | | Snow |
| Total-obscuraton | | | Drizzle |
| | | | Rain |
| | | | Blowing snow |
| | | | Volcanic ash |
| RANGE OF BASES | RANGE OF TOPS | | |
| BLO- <i>nnn</i> Below <i>nnn</i> | BLO- <i>nnn</i> Below <i>nnn</i> | | |
| SFC- <i>nnn</i> Surface to <i>nnn</i> | <i>nnn-nnn</i> | | |

| SURFACE VISIBILITY | | |
|----------------------------------|---------------------------------------------|---------------------|
| OBSTRUCTION | INTENSITY | REMARKS |
| Blowing Sand | Light | In Low Lying Areas |
| Blowing Dust | Moderate | Over Higher Terrain |
| Haze | Heavy | Locally |
| Smoke | | |
| Fog | | |
| Drizzle | | |
| Freezing Drizzle | | |
| Rain | | |
| Freezing Rain | | |
| Freezing Precipitation | | |
| Snow | | |
| Snow Showers | | |
| Blowing Snow | | |
| Ice Pellets | | |
| RANGE OF TOPS | SURFACE VISIBILITY | |
| BLO- <i>nnn</i> Below <i>nnn</i> | <i>nn-nn</i> | |
| <i>nnn-nnn</i> | L1- <i>nn</i> Less than 1 mile to <i>nn</i> | |
| | <i>nn-G6</i> <i>nn</i> to greater than 6 | |
| | L1 Less than 1 mile | |
| | G6 Greater than 6 miles | |

| CONNECTIVE ACTIVITY | | | | | |
|---------------------------------------|----------------------------------|---------------------------------------------|-------------------|------------------|-------------------|
| ACTIVITY | COVERAGE | COVERAGE REMARKS | THUNDERSTORM TYPE | SHOWER INTENSITY | INTENSITY REMARKS |
| Showers | Isolated | Diminishing | Embedded | Light | Diminishing |
| Thunderstorms | Widely Scattered | Increasing | Severe | Moderate | Increasing |
| | Scattered | In Mountains | Severe-Embedded | Heavy | |
| | Numerous | | | | |
| RANGE OF BASES | RANGE OF TOPS | VISIBILITY | | | |
| BLO- <i>nnn</i> Below <i>nnn</i> | BLO- <i>nnn</i> Below <i>nnn</i> | <i>nn-nn</i> | | | |
| SFC- <i>nnn</i> Surface to <i>nnn</i> | <i>nnn-nnn</i> | L1- <i>nn</i> Less than 1 mile to <i>nn</i> | | | |
| <i>nnn-nnn</i> | | <i>nn-G6</i> <i>nn</i> to greater than 6 | | | |
| | | L1 Less than 1 mile | | | |
| | | G6 Greater than 6 miles | | | |

| ICING | | | | |
|---------------------------------------|-----------------|-------------------|------------|------------------|
| TYPE | INTENSITY | INTENSITY REMARKS | COVERAGE | COVERAGE REMARKS |
| Rime | Light | Diminishing | Isolated | Diminishing |
| Clear | Light-moderate | Increasing | Scattered | Increasing |
| Mixed | Moderate | | Widespread | |
| | Moderate-severe | | | |
| | Severe | | | |
| HEIGHT | | | | |
| BLO- <i>nnn</i> Below <i>nnn</i> | | | | |
| SFC- <i>nnn</i> Surface to <i>nnn</i> | | | | |
| <i>nnn-nnn</i> | | | | |

| TURBULENCE | | | | |
|---------------------------------------|-----------------|-------------------|--------------------|------------------|
| TYPE | INTENSITY | INTENSITY REMARKS | COVERAGE | COVERAGE REMARKS |
| Clear Air | Light | Diminishing | Isolated | Diminishing |
| Mountain Wave | Light-moderate | Increasing | Scattered | Increasing |
| In Cloud | Moderate | | Widespread | |
| Low Level Wind Shear | Moderate-severe | | Over Rough Terrain | |
| Strong Surface Winds | Severe | | | |
| HEIGHT | | | | |
| BLO- <i>nnn</i> Below <i>nnn</i> | | | | |
| SFC- <i>nnn</i> Surface to <i>nnn</i> | | | | |
| <i>nnn-nnn</i> | | | | |

.....
All RANGE's and HEIGHT's are given in hundreds of feet MSL.
All VISIBILITY's are given in nautical miles and default to G6.
All other values default to "none."