

NEW FEATURES OF DIFFERENT FREQUENCY GENERATING SYSTEMS DUE  
TO THE USE OF ELECTRODELESS RIGIDLY MOUNTED BVA QUARTZ  
CRYSTAL RESONATOR

A. Jendly/E. Graf/G. Busca  
OSCILLOQUARTZ S.A.  
Brévard 16  
2002 NEUCHATEL - Switzerland

D.A. Brownsea  
PLESSEY ELECTRONIC SYSTEMS LTD.  
Grange Road  
CHRISTCHURCH - England

ABSTRACT

Design and production data of BVA quartz crystal resonators and oscillators have been presented in the past at the Frequency Control Symposium. [1,2,3,4]

The BVA 5 MHz crystal equipped frequency sources exhibit a new blend of remarkable performances such as  $10^{-11}$  daily stability,  $5 \times 10^{-13}$  short term stability (1 to 30 s time intervals) and close to the carrier low phase noise (1 Hz : -120 dBc, 10 Hz : -140 dBc), whereby retaining the customary crystal oscillator benefits of small volume, high reliability and low price, as opposed to more sophisticated frequency generators which would be required to achieve comparable performances.

Examples illustrating the impact of the Oscilloquartz BVA OCXO in different frequency generating systems will be presented :

- in cesium frequency standards
- in a hydrogen frequency standard
- in a precision distribution sub-system for satellite ground stations
- in high hierarchy exchanges of digital networks, synchronized by the master-slave method

PRECEDING PAGE BLANK NOT FILMED

## INTRODUCTION

Over the past 4 years, OSCILLOQUARTZ S.A. went through the various and challenging steps of turning the basic "BVA CONCEPT" into an industrial product, then to put that product into the field.

This paper intends to focus on the last portion of the program, namely to describe where and why BVA oscillators have been chosen for various frequency generating devices, and how such devices benefit from the BVA technology.

### PRODUCT DESCRIPTION : BVA RESONATOR

The BVA unit we are discussing here, consists of an "electrodeless" resonator at 5 MHz, 5th overtone, AT-cut, which is decoupled from his mounting structure by 4 bridges. These bridges are precisely made (width : 0.4 mm) and located and serve the purpose of keeping the mounting stress away from the active center part (resonator) as much as possible.

The electrodes are evaporated on two counterpieces, like condensers, also made of AT quartz blanks with the same cutangle as the resonator blank (see fig. 1).

The 3 parts are rigidly held together with stainless steel clips, and the whole sandwich is spring-mounted into a rigid cage consisting of a base plate and a cover plate which are fixed to four columns.

The BVA assembly is mounted in a cold-weld enclosure with a chimney which enables to bake out the finished resonator at 250°C while pumping it to  $10^{-8}$  mbar with a cryo pumping system and sealing the enclosure by a pinch-off process (see fig. 2).

This fairly complex structure offers many advantages, namely :

- the "electrodeless design" eliminates most of the problems linked to surface perturbations and ion migrations
- the use of a crystal resonator mounting made out of quartz material eliminates the problems linked to discontinuities, relaxation and stresses in the mounting points
- the reduction of space surrounding the active part eliminates the problem linked to contamination

Typically, the BVA resonator provides the following characteristics (5 MHz AT 5th overtone unit) :

$$\begin{aligned} Q &= 2.5 \times 10^6 \\ R_1 &= 80 \Omega \\ C_1 &= 1.02 \times 10^{-4} \text{ pf} \\ C_0 &= 4.1 \text{ pf} \end{aligned}$$

ORIGINAL PAGE IS  
OF POOR QUALITY

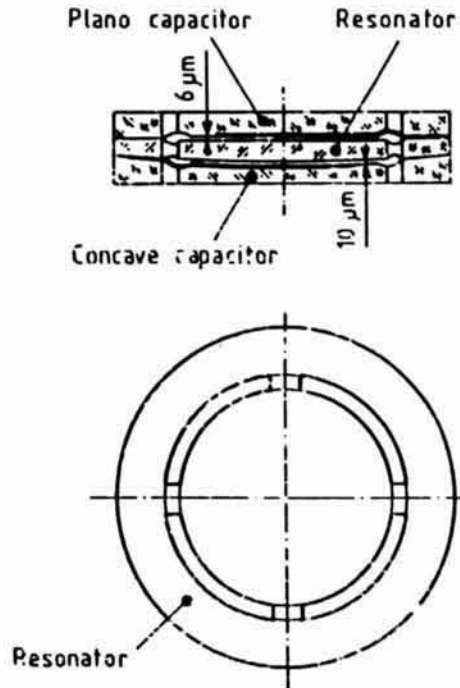

FIGURE 1 : BVA INNER ASSEMBLY

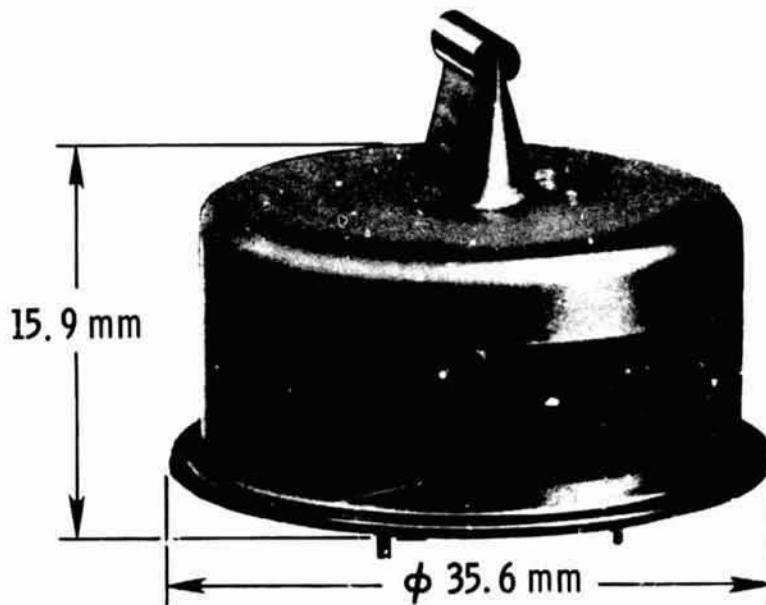

FIGURE 2 : BVA RESONATOR (COMPLETE)

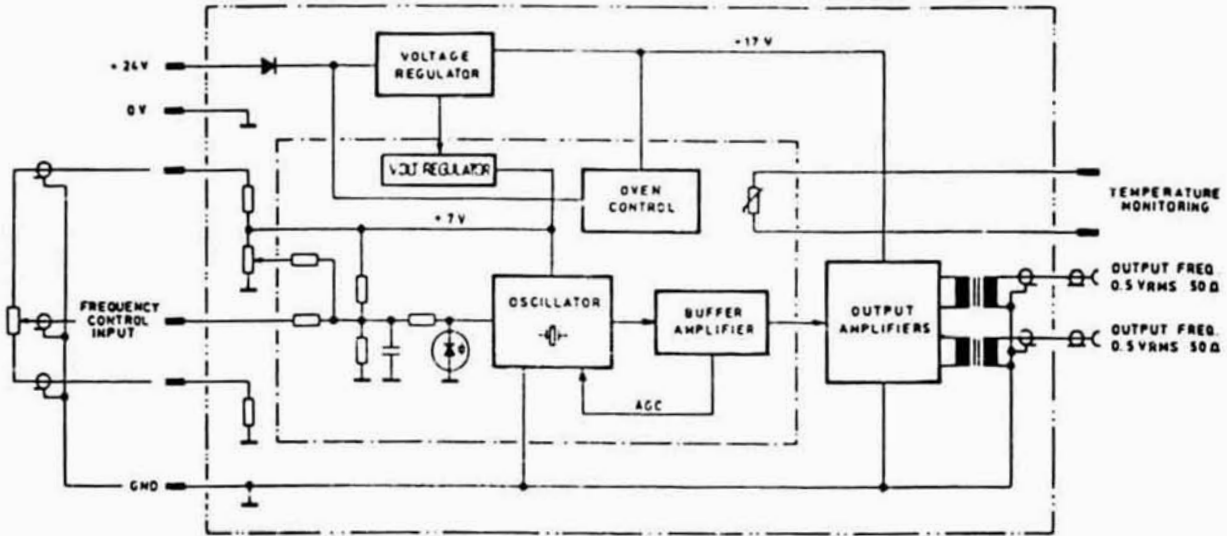

FIGURE 3 : OSCILLATOR BLOCK DIAGRAM (MODEL 8600/8601)

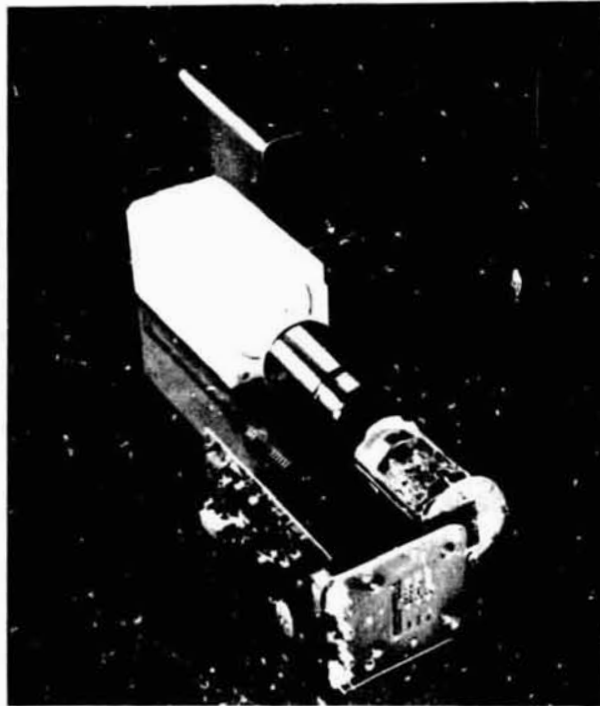

FIGURE 4 : BVA OSCILLATOR (MODEL 8600/8601)

PRODUCT DESCRIPTION : BVA OSCILLATOR

To match the outstanding performances of the resonator, the electronics of our best OCXO B-5400 has been redesigned, with high emphasize on low noise and high stability at all levels of the package. Basically, the BVA oscillator (so-called 8600 or 8601) includes the following sub-sections (see fig. 3 and 4).

- Inside the oven assembly :
- BVA resonator
  - 5 MHz oscillator and automatic gain control
  - Frequency pulling network
  - oven control circuit
  - 17 V/7 V voltage regulator

- Outside the oven assembly :
- thermal isolation
  - 24 V/17 V voltage regulator
  - dual output buffers
  - mechanical frequency adjustment

The most significant features and performances of the BVA oscillator can be outlined as follows (typical values) :

- long term stability :  $\leq 1 \times 10^{-10}$ /month
- short term stability ( $\sigma_T$ ) :  $\leq 5 \times 10^{-13}$  for  $\tau = 0.2$  to 30 sec
- phase noise (  $S_{\psi}$  ) : at 1 Hz = -120 dB / at 100 Hz = -150 dB
- static "g" sensitivity :  $5 \times 10^{-10}$ /g

In these areas, the BVA oscillator has considerably improved the performances obtained with commercially available OCXOs, and has set new standards to this category of frequency sources. This further, closes the gap between the best OCXOs and the Rb sources offered on the market.

It should also be noted that due to its relative simplicity, the BVA oscillator compares very advantageously to its nearest atomic competitor (rubidium standards) both in terms of prices and reliability.

We shall now take a closer look at the various possibilities offered with this device, when integrating it into various frequency generating systems.

### APPLICATION IN CESIUM FREQUENCY STANDARDS

Combined requirements for high accuracy and good spectral purity of the output signal can be found in Doppler Radar Networks, where many observation sites must operate in perfect synchronization.

A cesium standard with BVA oscillator offers the ideal solution to fulfill these requirements :

- the cesium accuracy enables plesiosynchronization of the network while
- the BVA oscillator guarantees the spectral purity of the distributed output

The crystal oscillator in a cesium frequency standard loop (see fig. 5) serves the following purposes :

- provides a 5 MHz output to the user and to the multiplier chain
- contributes to the determination of the loop time constant
- contributes to the phase performances of the output signal ( $S\psi$ ) for Fourier frequencies located above the loop band-width
- contributes to the short term stability performances of the output signal ( $\sigma_T$ ) for the time intervals ( $\tau$ ) shorter than the loop time constant

For a given device (in our example, the cesium oscillator OSA 3000), the replacement of the flywheel oscillator (conventional AT-P5 OCXO) by a BVA oscillator results in the following advantages :

POSSIBILITY TO INCREASE THE LOOP TIME CONSTANT FROM 1 TO 3 sec (SHORT)  
AND/OR 10 TO 30 sec (LONG)

A conventional AT-cut, 5th overtone crystal oscillator has a typical static g-sensitivity of  $2 \times 10^{-9}/g$  while the BVA oscillator improves that figure by a factor of 4 (typically  $5 \times 10^{-10}/g$ ). In the cesium loop, the BVA oscillator can therefore be more closely locked to the cesium beam tube, thus allowing a better exploitation of its superior short term stability and spectral purity.

#### IMPACT ON THE PHASE NOISE PERFORMANCES

With a time constant set to either 3 or 30 sec, the cesium standard now exhibits the following characteristics (see fig. 6) :

Frequency offset from carrier	$S\psi \tau = 3 \text{ sec}$	$S\psi \tau = 30 \text{ sec}$
1 Hz	- 90 dB	-105 dB
10 Hz	-132 dB	-136 dB
100 Hz	-145 dB	-145 dB
1'000 Hz	-145 dB	-145 dB
10'000 Hz	-145 dB	-145 dB

ORIGINAL PARTS  
OF POOR QUALITY

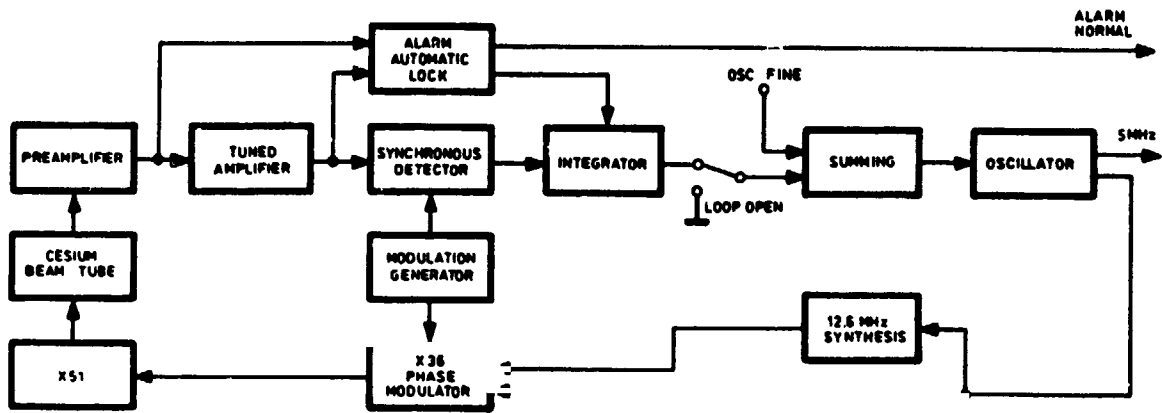

FIGURE 5 : CESIUM FREQUENCY OSCILLATOR BLOCK DIAGRAM

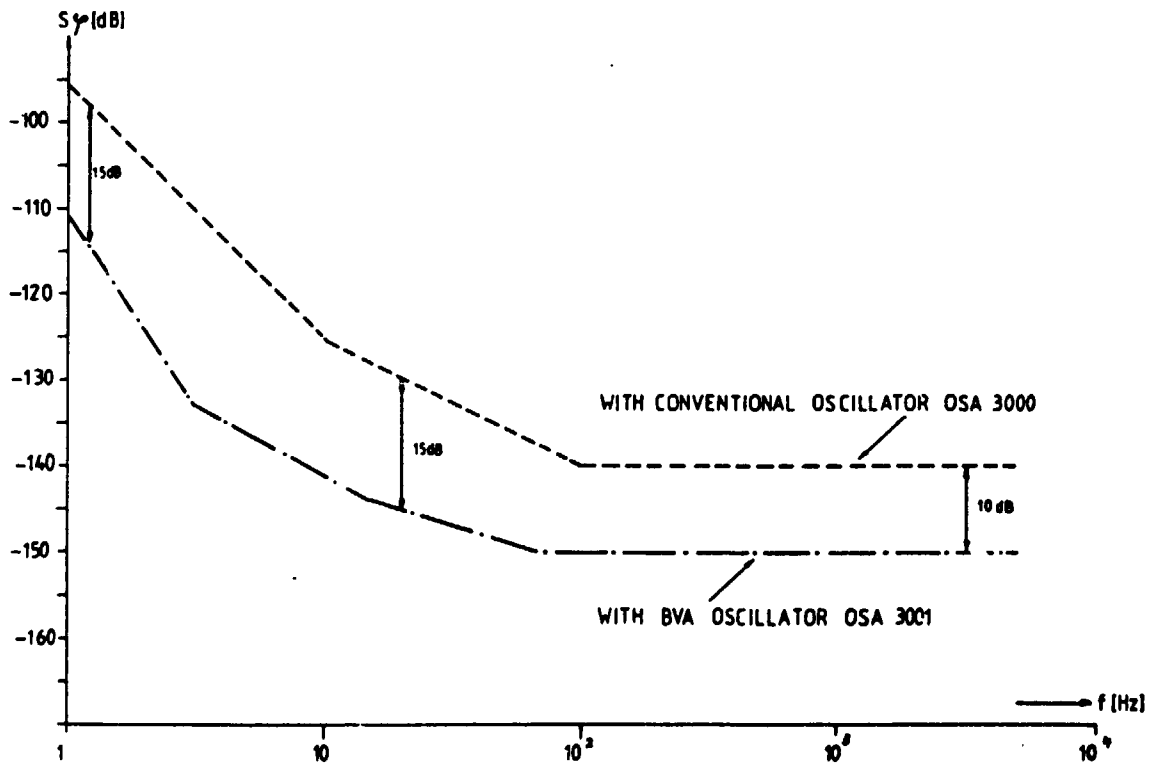

FIGURE 6 : 3000/3001 - PHASE NOISE DATA PLOT ( $10^0 + 10^4$  Hz)

IMPACT ON THE SHORT TERM STABILITY PERFORMANCES

With a time constant set to either 3 or 30 sec, the cesium standard now exhibits the following characteristics (see fig. 7) :

Time interval ( $\tau$ )	$\sigma$ ( $\tau = 3$ sec)	$\sigma$ ( $\tau = 30$ sec)
0.1 sec	$5 \times 10^{-12}$	$1 \times 10^{-12}$
1 sec	$2 \times 10^{-11}$	$2 \times 10^{-12}$
10 sec	$9 \times 10^{-12}$	$4 \times 10^{-12}$
100 sec	$3 \times 10^{-12}$	$3 \times 10^{-12}$

Figure 6B provides the same data, looking at Fourier frequencies very close-in to the carrier. Assuming that the equipment could operate in a very stable environment, the loop time constant could even be increased to 100 sec, providing even better results.

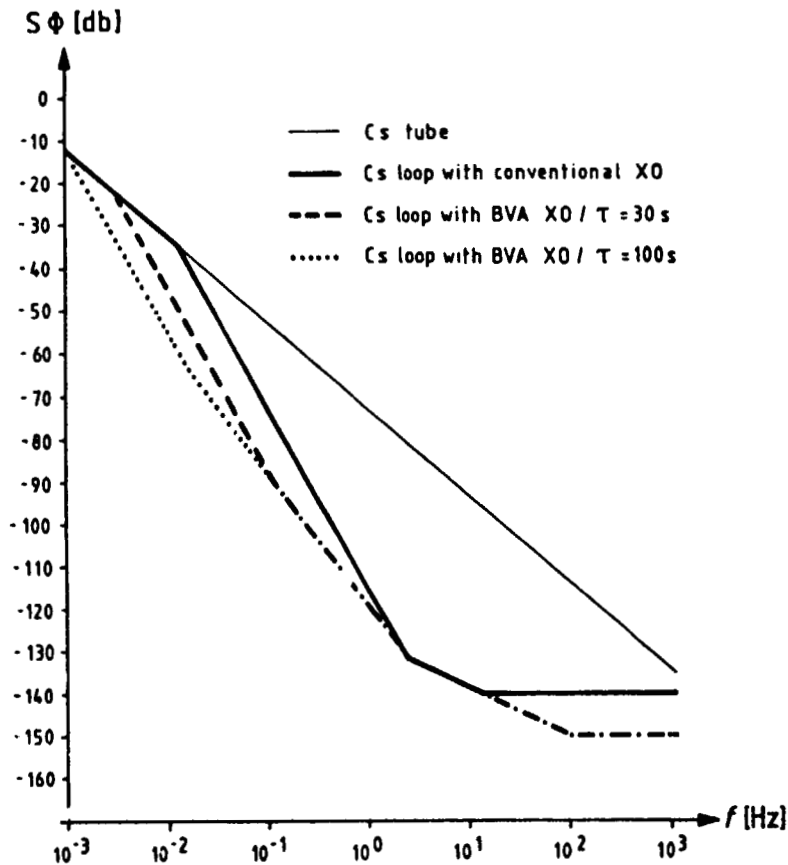

FIGURE 6B : 300G/3001 PHASE NOISE DATA PLOT ( $10^{-3}$  -  $10^3$  Hz)



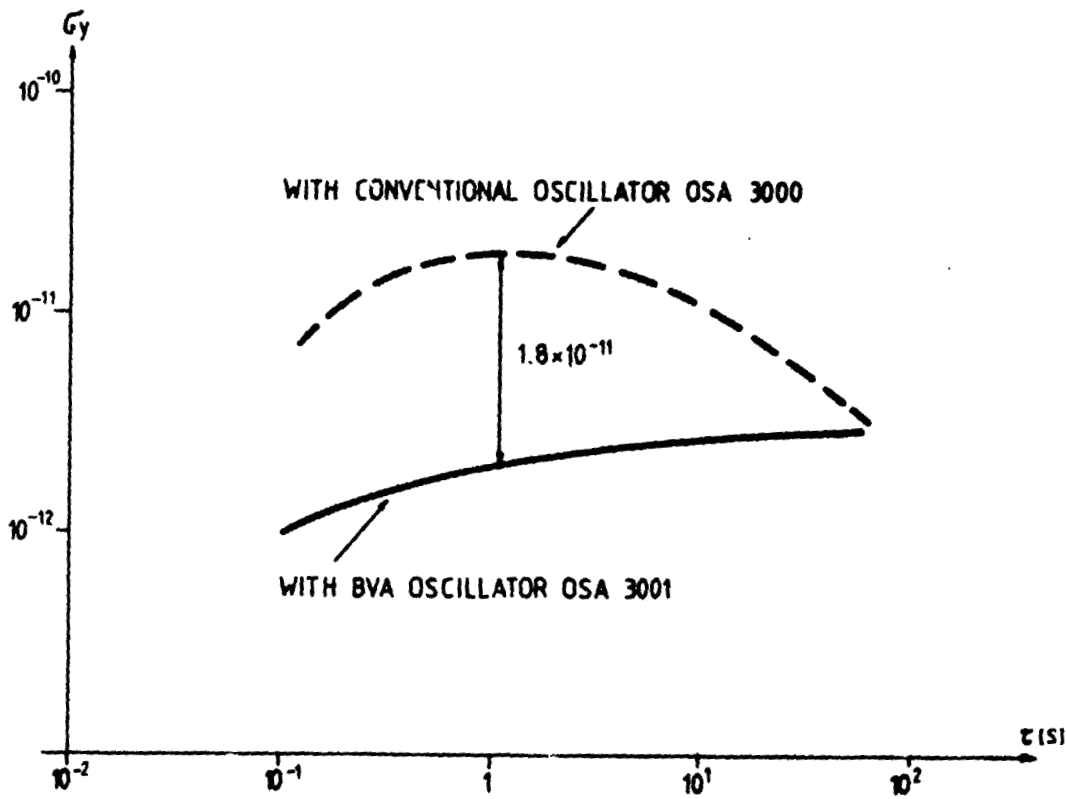

FIGURE 7 : 3000/3001 SHORT TERM STABILITY DATA PLOT ( $10^{-2} - 10^2$  s)

APPLICATION IN A HYDROGEN MASER

The use in radioastronomy and VLBI (Very Long Baseline Interferometry) of increasingly higher observation frequencies creates a unique requirement for an oscillator having the lowest spectral density of phase fluctuations ( $S_{\psi}$ ) obtainable for both high Fourier frequencies (i.e. from 1 Hz up to a few MHz) and low Fourier frequencies (i.e. down to  $10^{-5}$  Hz). The LO (Local Oscillator) signal needed for a radioastronomy receiver is normally derived from an H-maser atomic signal through at least 2 phase lock loops (see fig. 8). A VCXO (Voltage Controlled Crystal Oscillator) having normally a 5 MHz output frequency is phase locked to the atomic signal with a typical loop bandwidth of a few Hz, and the microwave oscillator is phase locked to the VCXO signal. The bandwidth of this last PLL (Phase Locked Loop) depends on the phase noise characteristics of the microwave oscillator and is typically of the order of  $10^5$  Hz. The reason behind that design resides in the fact that the atomic signal has the lowest phase noise for Fourier frequencies below 1 Hz, the VCXO multiplied to the LO frequency has normally the lowest phase noise in the Fourier frequency range between 1 and  $10^5$  Hz and the microwave oscillator has the lowest phase noise for Fourier frequencies above  $10^5$  Hz. Here we are concerned mostly with the phase locking of the VCXO on the atomic signal.

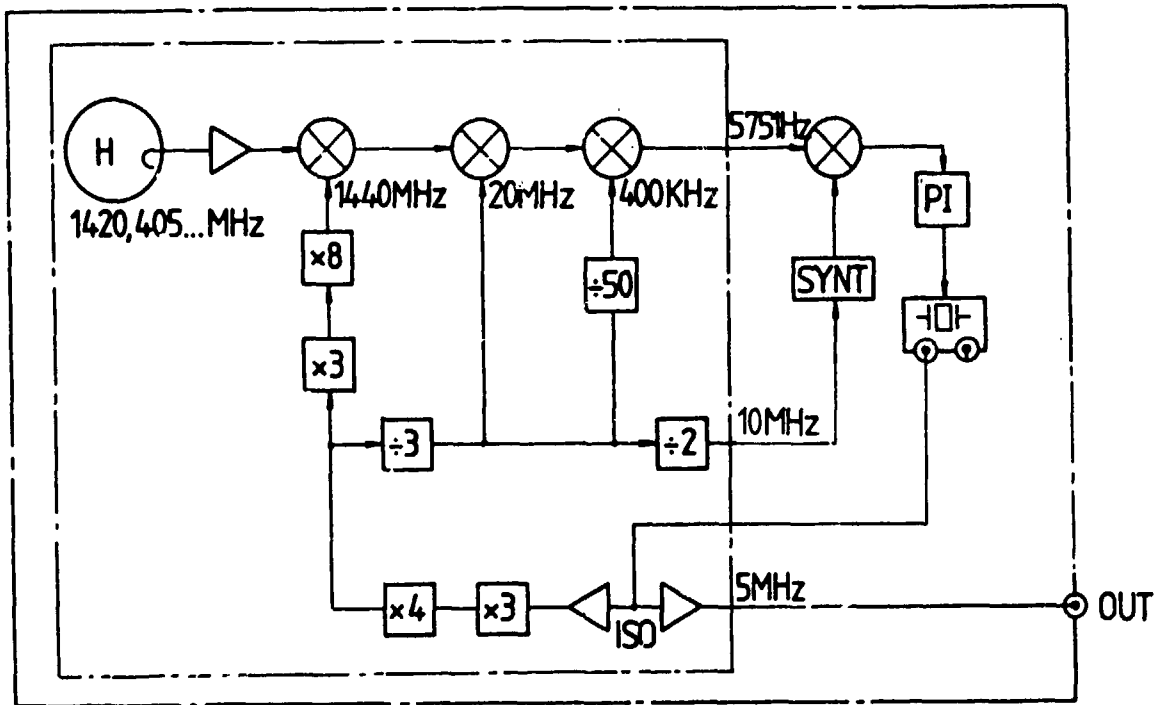

FIGURE 8 : MASER PHASE-LOCK SYSTEM

## REALISATION OF AN "OPTIMUM" PLL

The state-of-the-art 5 MHz BVA quartz crystal oscillators (4) has a spectral density, at 5 MHz, given by

$$S_{\psi Q} = 10^{12.2} x f^{-3} + 10^{-13.2} x f^{-1} + 10^{-15.7} x f^{-0} \quad [6]$$

A maser oscillator typical phase noise referred to 5 MHz is given by (4)

$$S_{\psi A} = 10^{12.9} x f^{-2} + 10^{-11.1} x f^0 \quad [4]$$

An "optimum" PLL similar to the one described in ref. 7 has been designed and realized according to the criterion of minimum integrated rms phase noise. The experimental results are in good agreement with the theoretical calculation and are represented, at the 5 MHz output frequency, in fig. 9, 10 and 11, for Fourier frequencies above 1 Hz. The result derived from the final setting (fig. 11) is believed to be one of the best available today and is still susceptible to an improvement of 15 dB in the white phase noise region. The previous results give a total rms time jitter of 0.32 ps in the 1 Hz-100 kHz bandwidth, this means that this maser could be conveniently used up to 200 GHz interferometer frequency with a negligible 10% coherence loss. For the details of the calculation we refer to ref. 5

## SPECIFICATIONS DETERMINATION - FREQUENCY STABILITY

In addition to the previous discussion of the requirement of the short term/long term frequency stability the following comment is in order. The optimum PLL previously described can be used conveniently only in vibration free environments, because the loop bandwidth is approximately 0.5 Hz and the BVA oscillator g-sensitivity  $5 \times 10^{-10}/g$  the slow coherence requirement normally is translated in the following specification for the Allan Variance :

$$\text{and } \begin{aligned} \sigma_y(\tau) &= 7 \times 10^{-13} \tau^{-1} & 1 \leq \tau \leq 100 \text{ sec} \\ \sigma_y(\tau) &= 2 \times 10^{-15} \tau^0 & 1'000 \leq \tau \leq 10'000 \text{ sec} \end{aligned}$$

which appears fully satisfactory in consideration of the  $1 \times 10^{-14}$  Allan variance limitation imposed by the atmosphere itself. The 5 EFOS H-masers (8) constructed and tested in our laboratory have shown consistently stabilities within the previous specs (see fig. 9).

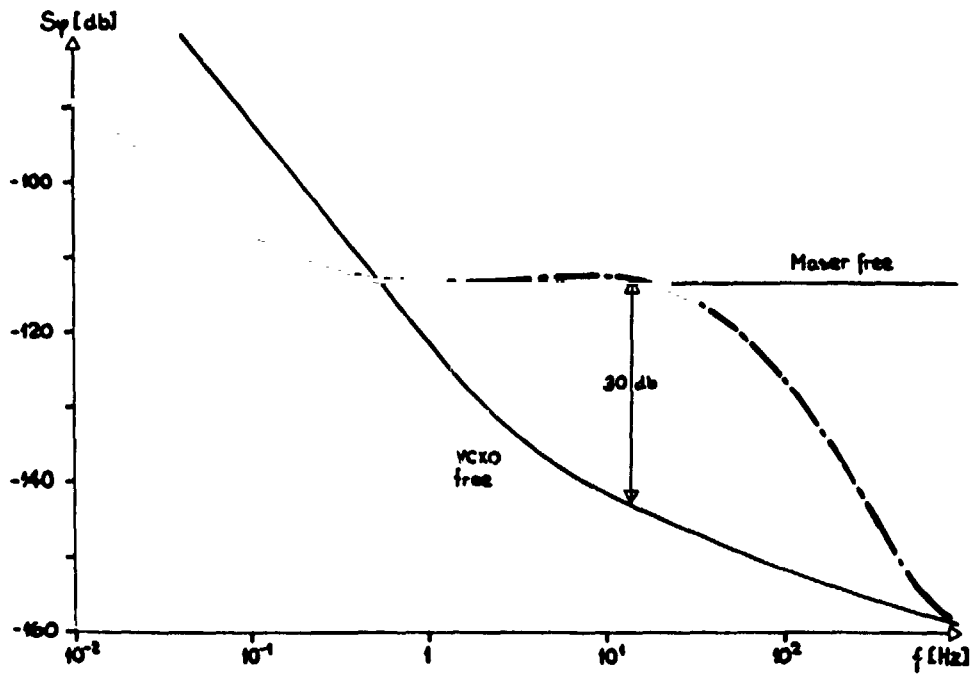

FIGURE 9 : MASER PLL & VCXO TYPE BVA 8601/5 MHz  
 $F_n = 10.6$  Hz

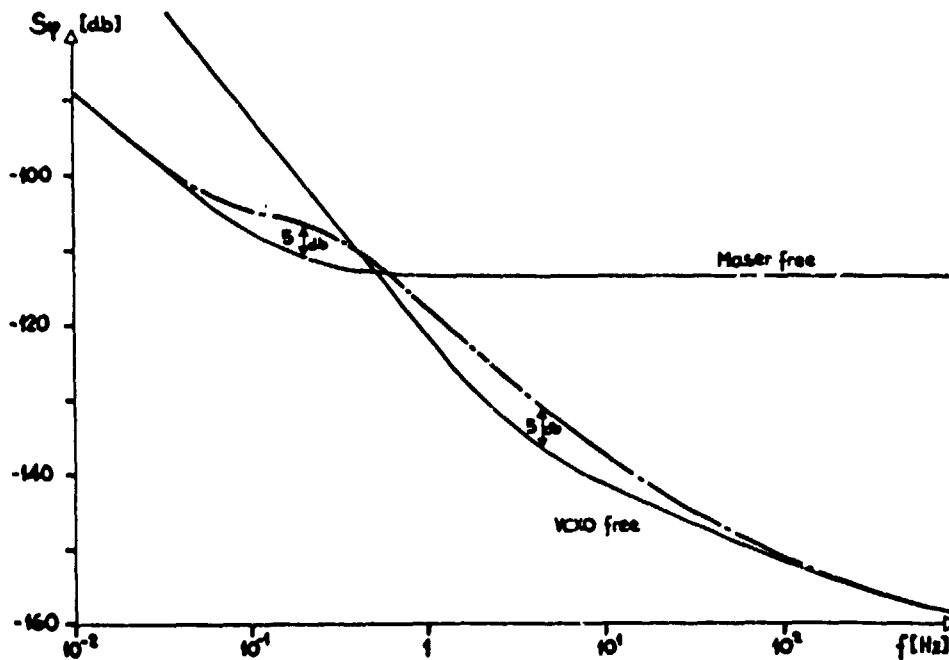

FIGURE 10 : MASER PLL & VCXO TYPE BVA 8601/5 MHz  
 $F_n = 0.25$  Hz

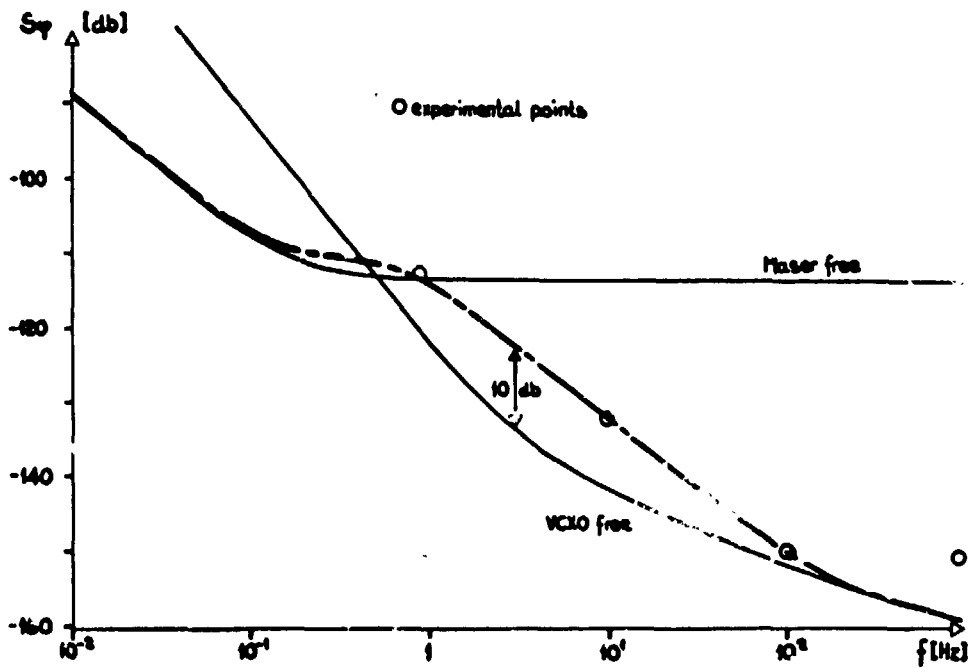

FIGURE 11 : MASER PLL & VCXO TYPE BVA 8601/5 MHz (FINAL SETTING)  
 $F_n = 0.55$  Hz

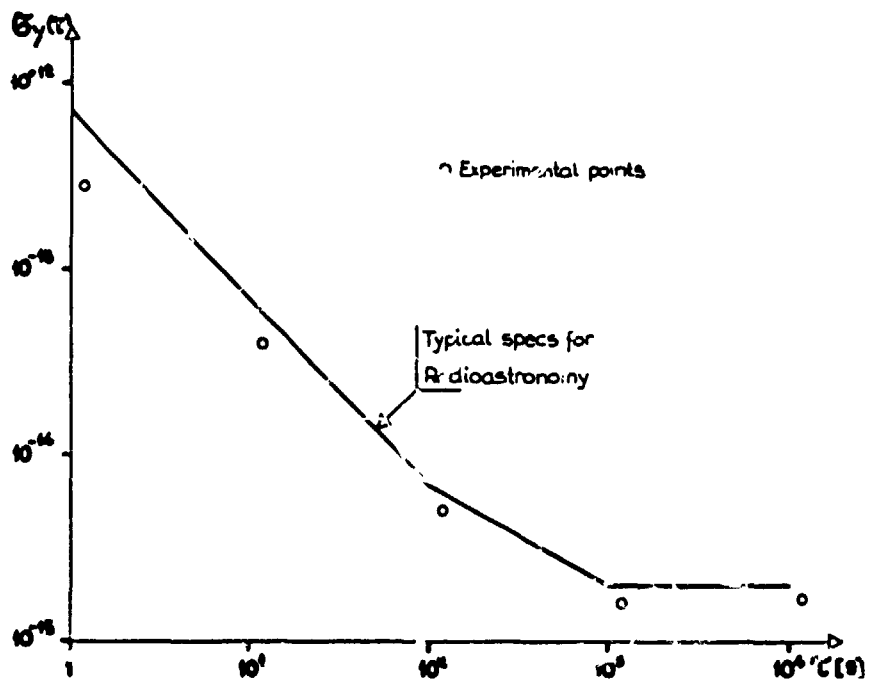

FIGURE 12 : EFOS MASER FREQUENCY STABILITY

## APPLICATION IN PRECISION DISTRIBUTION SUB-SYSTEM FOR SATELLITE GROUND STATION

### DESIGN PHILOSOPHY

With the requirements in satellite communication systems to make maximum usage of the frequency spectrum, coupled with the reliability and availability requirements of a state-of-the-art communications system, the technical specification of a frequency distribution sub-system is extremely stringent, especially since the operation of the station is totally dependent on that sub-system.

In order to meet this high technical specification within a relatively short development timescale, a design was evolved making the maximum use of state-of-the-art proprietary equipment modules.

The main frequency references for the sub-system are provided by two crystal frequency standards, each including BVA oscillators.

Crystal oscillators although not as stable, long term wise, than rubidium standards, were used because of their extremely low phase noise and high MTBF.

Longer term trends in stability are determined by comparing the oscillator outputs with a rubidium standard. Considering the typical aging of the oscillator below 10-11/day, the number of periodic recalibration can be set to a minimum.

### IMPLEMENTATION

The sub-system may be conveniently divided into five main areas for consideration :

- THE FREQUENCY GENERATION
- INTERMEDIATE CABLING
- REMOTELY SITUATED AMPLIFIERS
- THE POWER SUPPLY

The relationship between these areas can be seen in fig. 13.

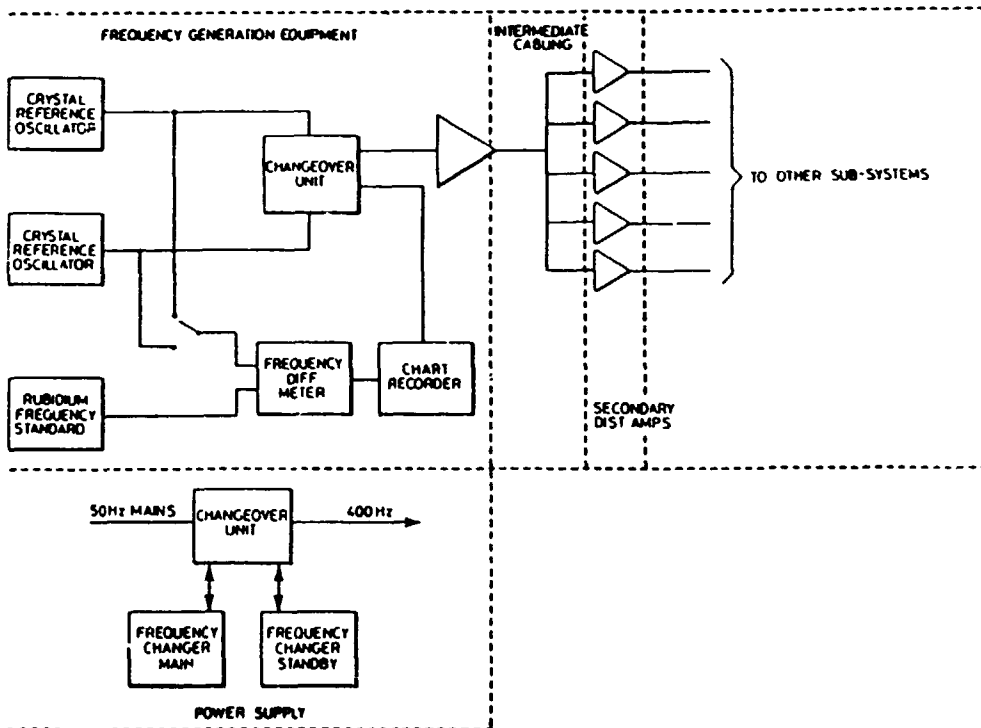

FIGURE 13 : FREQUENCY DISTRIBUTION SUB-SYSTEM -BLOCK DIAGRAM-

### FREQUENCY GENERATION EQUIPEMENT (see fig. 14)

Two frequency references are provided in the frequency generation equipment. These sources, each of which is provided with its own internal backup battery supply, contain a unique type of crystal oscillator which provides an output signal with a long term stability of better than  $\pm 2$  parts in  $10^{11}$  per day, ie approaching that of a rubidium standard. The outputs of these two reference sources are fed to an automatic changeover unit in order to increase the reliability and availability of the output. The output from the automatic changeover unit is in turn fed to a main distribution amplifier which provides the main feeds for the various areas. The output frequencies from the reference sources are compared to the output from a rubidium standard using a frequency difference meter, coupled with a chart recorder, enabling appropriate fractional changes to be effected manually. To further increase the availability, battery backup is provided for the whole rack of equipment and comprehensive monitoring is provided to enable faults to be quickly rectified.

### INTERMEDIATE CABLING

Having obtained a very high signal, it is essential that it is not degraded to any extent during transmission to other sub-systems. For this reason, a coaxial cable originally designed for electro-magnetic protection in nuclear reactors is used. It consists of three braids and two spirally wound mu-metal tapes. This provides greater protection against electro-magnetic interference than semi-rigid coaxial cables, whilst retaining a flexibility similar to that of standard coaxial cable. Special connectors are used with this cable in order to preserve its high shielding properties.

### REMOTELY SITUATED AMPLIFIERS

As many more outputs are required than can be supplied by one amplifier, further amplifiers are situated in the sub-systems that they serve. These amplifiers are of the same type as the main distribution amplifier and are once again of a very low noise design. Situating them in the same area as the equipments they serve keeps interference to a minimum and reduces cable costs. Each amplifier is coupled to an alarm unit to display power or frequency failure faults.

### POWER SUPPLY

Due to the requirements for extremely low phase noise outputs, it is also vitally important to avoid components in the phase noise that are derived from the power supply. Whilst it is not possible to eliminate 50 Hz mains components completely in an unshielded environment they are reduced by providing a 50 to 400 Hz power convertor. Most of the sub-system is run off 400 Hz, thus reducing the effect of the components produced. Generally, the 400 Hz components in the phase noise will fall outside the loop bandwidth of the RF convertors and the RF system is subsequently more tolerant of such components. The convertors are provided in duplicate together with automatic changeover to maintain the overall availability of the system.

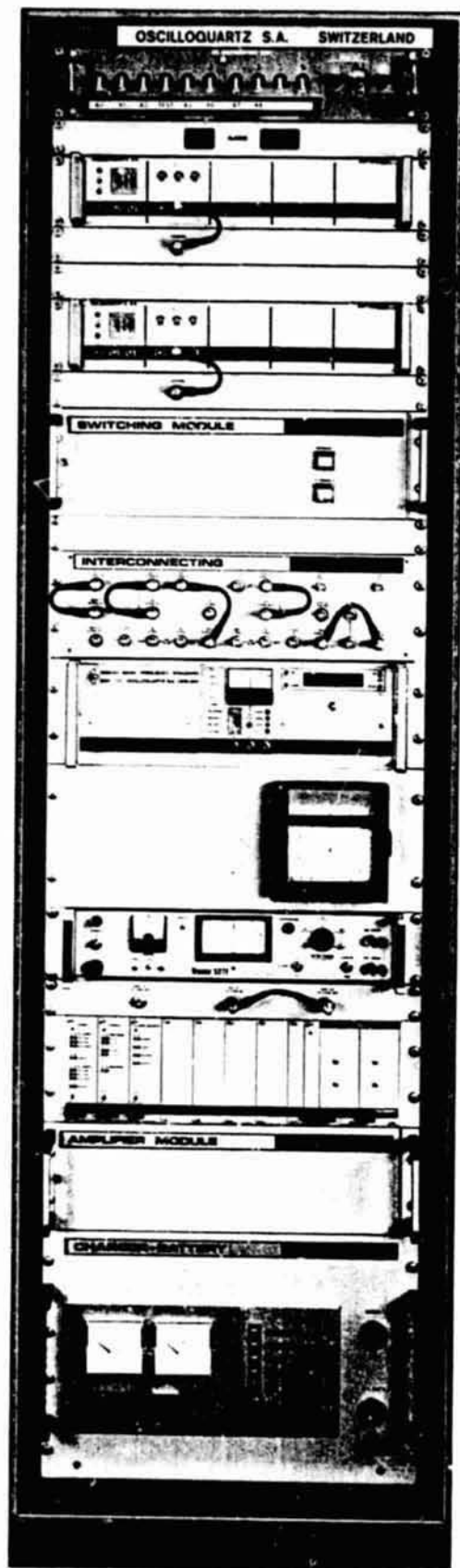

ORIGINAL PAGE IS  
OF POOR QUALITY

FIGURE 14 : FREQUENCY GENERATION EQUIPMENT



SUMMARY

The frequency sub-system meets the stringent technical requirements with a phase noise performance that represents the best available, using today's technology.

The phase noise figures obtained are equal to, or better than, the following :

Frequency offset from carrier (Hz)	SSB phase noise in 1 Hz bandwidth (dBc/Hz)
1	-110
10	-130
100	-140
1'000	-141
10'000	-141
100'000	-141

Now harmonically related and power supply related spurious phase noise components (spurs) are better than

- 144 dBc in the range of 1 Hz to 395 Hz from carrier
- and - 94 dBc in the range of 395 Hz to 10 kHz from carrier

The achievable system stability is : short term,  $\pm 1$  part in  $10^{11}$  per second  
long term,  $\pm 2$  parts in  $10^{11}$  per day

An available figure of 99.9995% ensures almost continuous on-line operation of the station.

The modularity of the sub-system makes simple provision for future expansion to meet new requirements. The sub-system can be either compressed or expanded in size, or modified to suit different physical constraints without affecting its essentially high technical specification.

APPLICATION IN A SYNCHRONIZED DIGITAL NETWORK

The needs and characteristics of reference clocks for digital communications systems are extensively described in ref. 10 and 11. From these information, we can summarize trends, facts and requirements as follows :

- Data transmissions by means of time division multiplex (TDMA) are becoming increasingly popular in modern telecommunication networks.
- International data communication are ruled by ITU (International Telecommunication Union), by means of CCITT recommendations.
- CCITT recommendation G-811 calls for a maximum frequency offset of  $\approx 1 \times 10^{-11}$  between two international exchanges. This value is based on the maximum error rate (or slip rate) allowable between two nodes to ensure proper data transmission.

To comply with this recommendation, trends are nowadays to achieve "frequency synchronization" :

- At an INTERNATIONAL LEVEL in a plesiosynchronous way, using master clock systems including cesium standards.
- At a NATIONAL LEVEL in a synchronous way, using synchronizing modules at each nodes connected directly or indirectly to the master clock.

A typical network configuration is given in fig. 15.

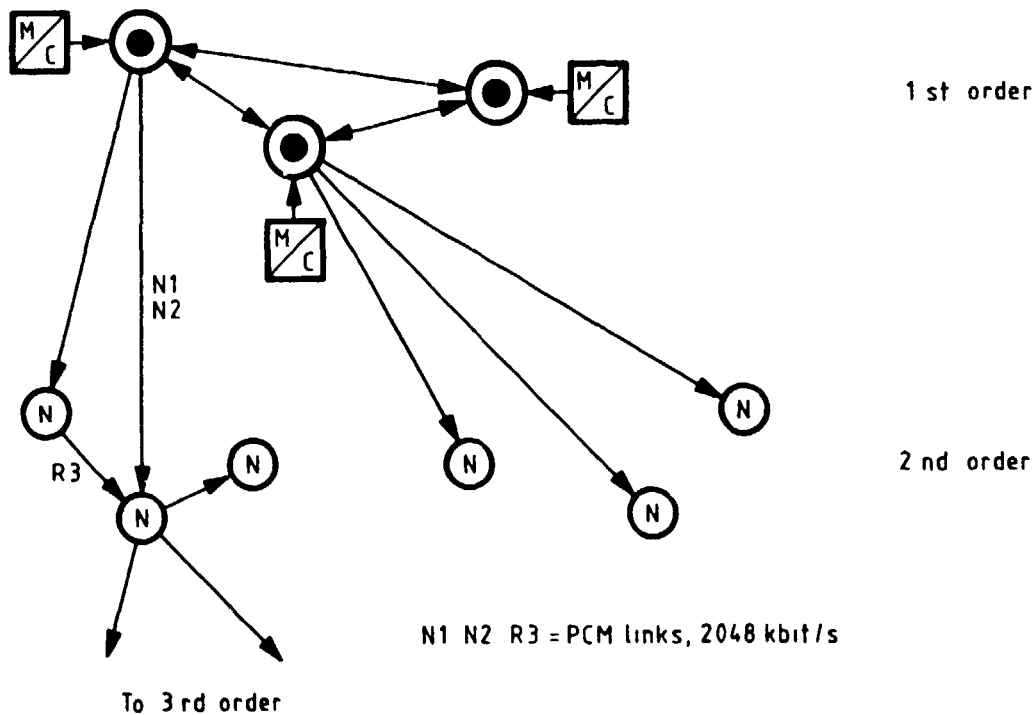

FIGURE 15 : TYPICAL NETWORK CONFIGURATION (MASTER SLAVE MODE)

TERMS AND DEFINITION

It should be mentioned at this stage that the requirements and concerns of the "telecommunications people" in terms of frequency sources are expressed in a very specific manner.

- "Oscillators people" like to define and characterize their product in terms of ACCURACY, STABILITY per unit of time or over a given environment, REPRODUCIBILITY, AGING, etc.
- "Telecommunication people" on the other hand specify their needs by using the following terms :

- JITTER : RMS phase deviation in a given bandwidth
- WANDER : systematic and/or random phase or time fluctuation, linked to cable delay, seasonal temperature variations, transmission effects, etc.
- TIE : "TIME INTERVAL ERROR"; definition of the clock performances limits given by the relation
 
$$\text{TIE}(t) = \Delta T(t + \tau) - \Delta T(t)$$

AVAILABILITY : time during which the system will remain within the CCITT G-811 limits, in case of degradation or absence of synchronizing reference

The latter is of particular interest to us since directly related to the long term stability (aging), of the fly-wheel oscillator in the synchronizing module. A low aging oscillator will indeed give more time to the operator for servicing the nodes in case of reference failure.

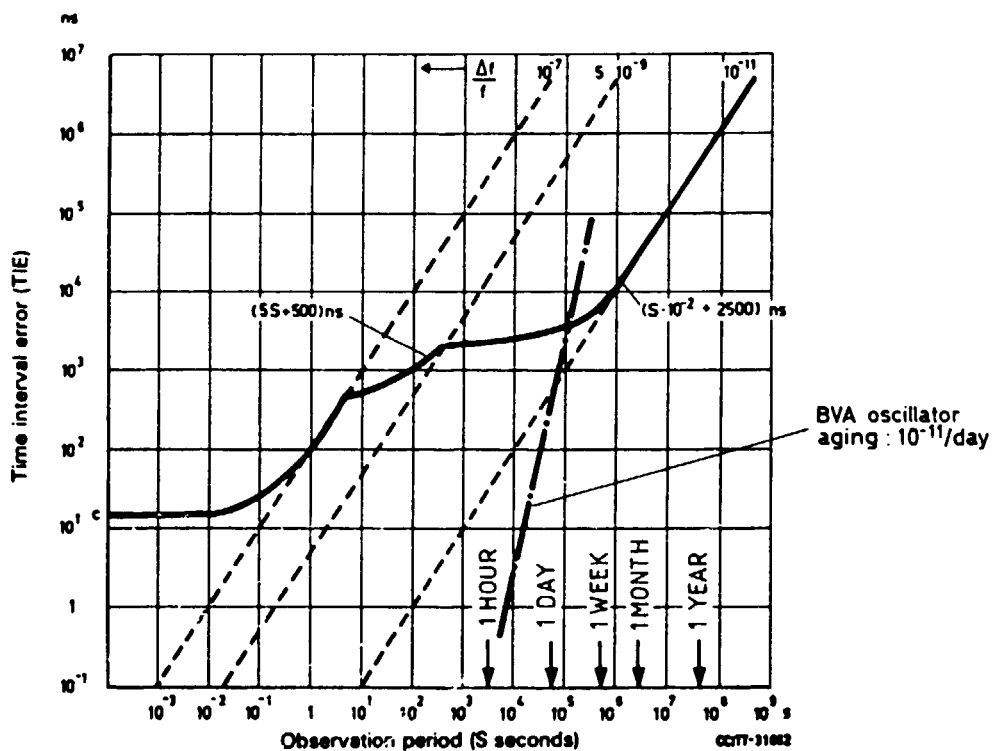

FIGURE 16 : TIME INTERNAL ERROR LIMITS, CCITT REC. G-811 (DRAFT REVISION 1980)

### SYNCHRONIZING MODULE

As previously shown (fig. 15), each node located at a secondary level is connected to one or several lines carrying the synchronization and reference signal (in our example, at 2048 kHz).

Each line also carries messages which, combined with the effects of distance and the nature of transmission, require special precaution to extract and use the reference frequency.

The main purpose of the synchronizing module is to extract, filter and regenerate, from this signal a clean reference frequency which is compatible to the CCITT recommendation G-811.

This frequency will be used for driving the frequency converter and distribution amplifiers intended for local use.

A typical 2nd level node configuration would consist of 3 synchronizing modules each driven by one or preferably several reference input lines (see fig. 17).

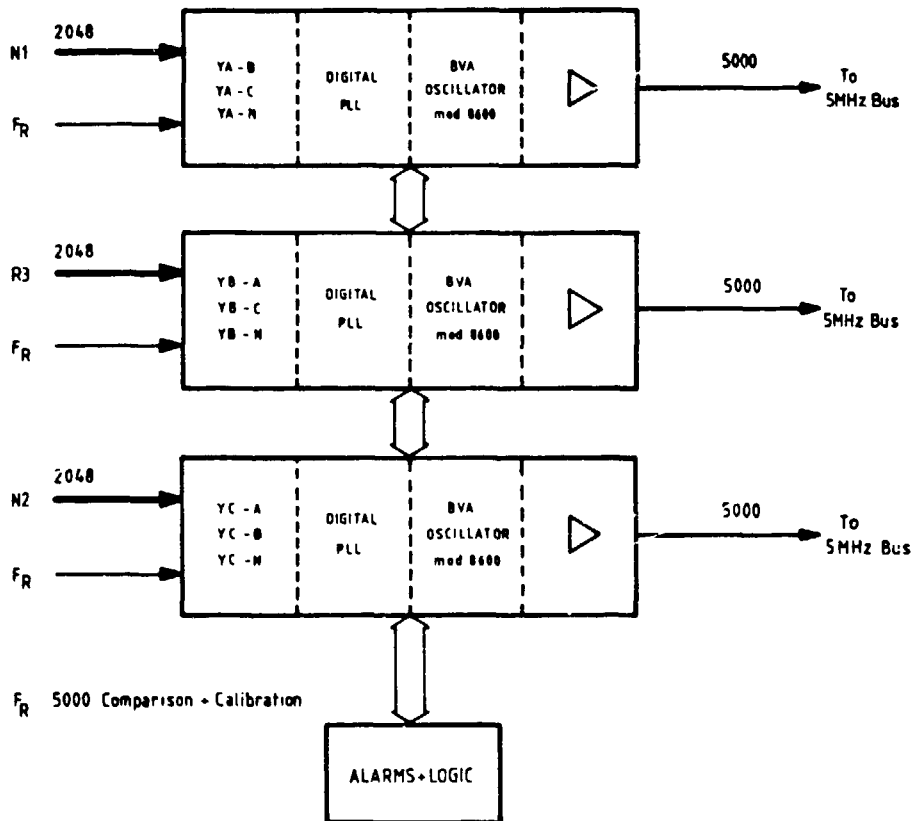

FIGURE 17 : TRIPPLICATE SYNCHRONIZING MODULE

### ROLE OF THE OSCILLATOR

In view of these different constraints, many features only offered with the BVA oscillator can be exploited to the benefit of the system performances :

<u>OSCILLATOR FEATURES</u>	<u>SYSTEM BENEFITS</u>
Very low aging rate ( $< 10^{-11}$ /day)	24 hours autonomy (availability in case of loss of reference)
Excellent short/medium term stability ( $\leq 5 \times 10^{-13}$ from 0.1 to 30 s) and low sensitivity to environmental changes	Possibility to use high PLL time constant, thus to improve the jitter rejection
High MIBF	Improves system's availability figure. Decreases servicing and operating costs
Linearized frequency control function	No variation of loop time constant with time (following compensation of XO aging)

The data plots provided in fig. 18 and 19 exhibit the performances of the synchronization module we realized for this application, based on the use of a BVA oscillator in a loop bandwidth of  $\sim 1 \times 10^{-4}$  Hz.

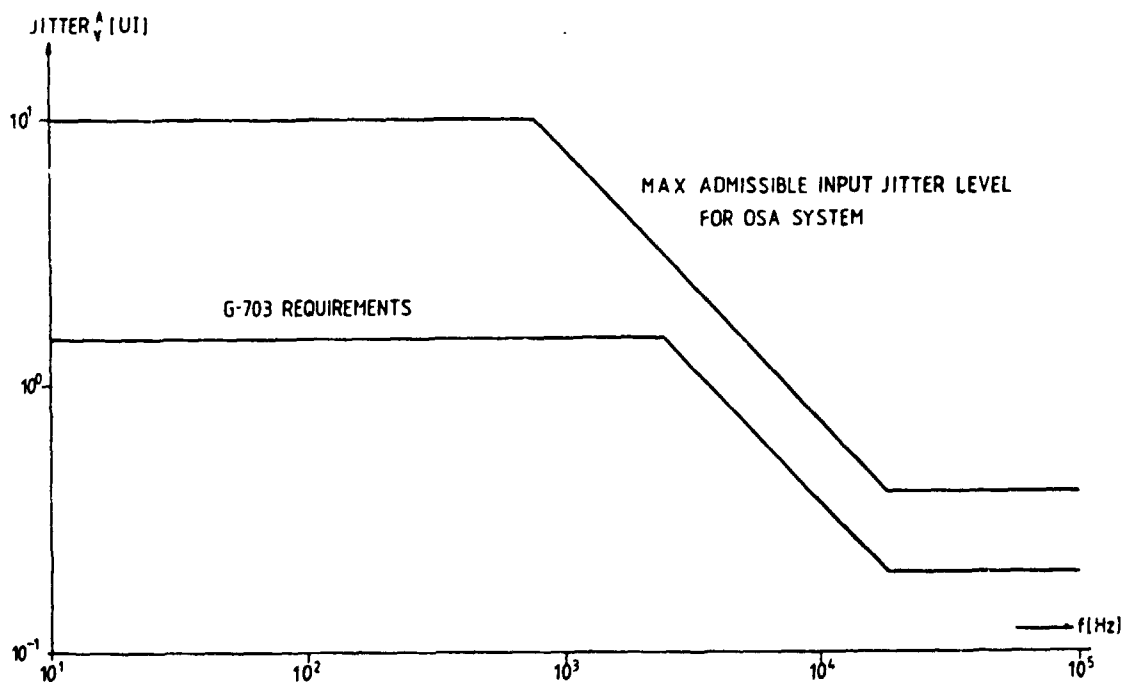

FIGURE 18 : MAX. JITTER LEVEL VS G-703 RECOMMENDATION

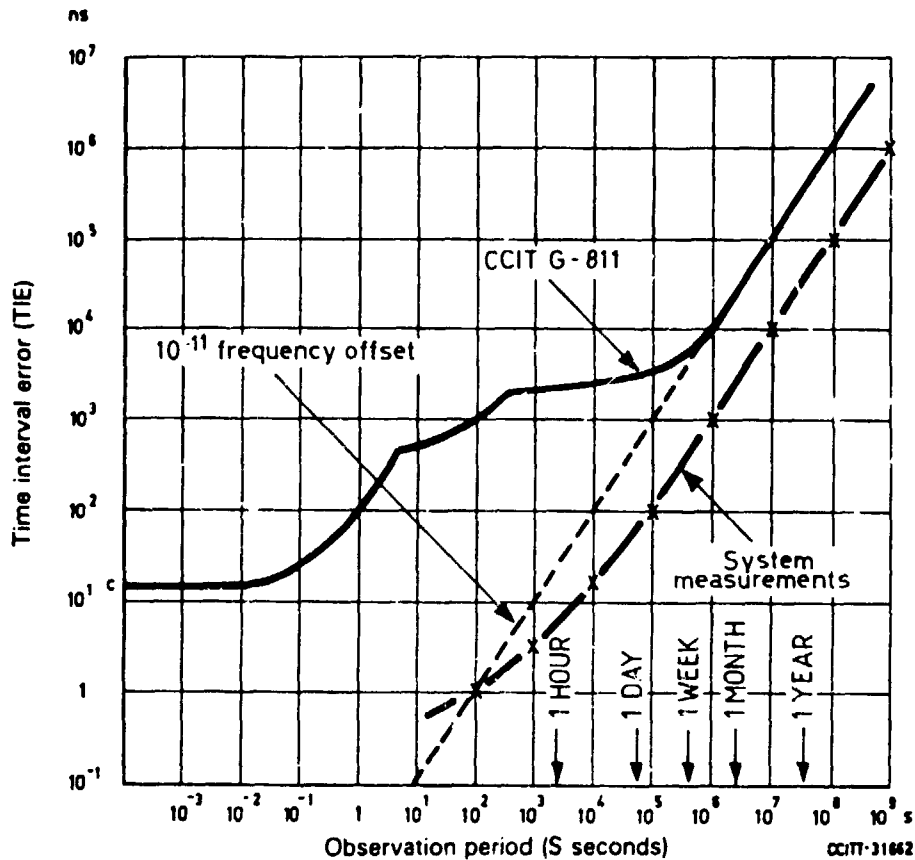

FIGURE 19 : PERMISSIBLE TIE (G-703) AND TYPICAL SYSTEM'S PERFORMANCES

#### CONCLUSIONS

- BVA oscillators have now reached industrial maturity both in terms of their production and applications.
- Substantial performances improvements have been demonstrated in various frequency generating devices, following the replacement of the conventional OCXO with a BVA oscillator.
- Developments based on the BVA technology are being conducted in the areas of HF OCXO and low g-sensitivity oscillators. These efforts, combined with the growing number of applications calling for very high performances frequency sources, are contributing to further improve the state-of-the-art in quartz crystal oscillators.

## REFERENCES

- 1) R. Besson, "A New Piezoelectric Resonator Design",  
Proc. 30th AFCS (1976), p. 78-83
- 2) R. Besson and U. Peier, "Further Advances on BVA Quartz Resonators",  
Proc. 34th AFCS (1980), p. 175-182
- 3) E.P. Graf, D.A. Emmons, et al., "Performance of New Oscillators Designed for  
'Electrodeless' Crystals",  
Proc. 34th AFCS (1980), p. 457-462
- 4) E.P. Graf, U. Peier "BVA Quartz Crystal Resonator and Oscillator Production. A  
Statistical Review",  
Proc. 37th AFCS (1983), p. 492-500
- 5) S. Weinreb, National Radio Astronomy Observatory Charlottesville, Virginia,  
Electronics Division, Internal Report No 223 "Short Term Phase Stability Requirements  
for Interferometer Coherence", June 1983
- 6) A.E. Rogers and J.M. Moran, IEE Transactions and Means, Vol 17 30, No 4, p. 283-286,  
December 1981
- 7) L. Probst, G. Busca and F.E. Gardiol, IEEE Trans. on Inst. and Measur., June 1984,  
Vol 33, No 2, p. 116
- 8) G. Busca et al., Proc. of the 36th Annual Frequency Control Symposium Philadelphia,  
1982, p. 260-264
- 9) B. Vessot, Proc. of the 15th Annual Precise Time and Time Interval (PTI) Appl. and  
Planning Meet., Washington 1983, in publication
- 10) P. Kartaschoff "Reference Clock Parameters for Digital Communications Systems  
Application"
- 11) P. Kartaschoff "Frequency Control and Timing Requirements for Communications Systems"

QUESTIONS AND ANSWERS

ALBERT BENJAMINSON, S. T. RESEARCH: Can you tell us more about the BVA resonator?

MR. JENDLY: Do you mean specifications?

MR. BENJAMINSON: Yes.

MR. JENDLY: Yes, they are in the paper. I can give you the paper right away, if you wish. The Q factor is 2.5 million, and the resistance is 280 ohms, and  $C_1$  and  $C_p$  I can give you right away.