

ATOMIC HYDROGEN MASER ACTIVE OSCILLATOR  
CAVITY AND BULB DESIGN OPTIMIZATION

H. E. Peters and P. J. Washburn

Sigma Tau Standards Corporation  
Tuscaloosa, Alabama

## ABSTRACT

The performance characteristics and reliability of the active oscillator atomic hydrogen maser depend upon "oscillation parameters" which characterize the interaction region of the maser: the resonant cavity and atom storage bulb assembly. With particular attention to use of the cavity frequency switching servo (1) to reduce cavity pulling, it is important to maintain high oscillation level, high atomic beam flux utilization efficiency, small spin exchange parameter and high cavity quality factor. It is also desirable to have a small and rigid cavity and bulb structure and to minimize the cavity temperature sensitivity. In this paper we present curves for a novel hydrogen maser cavity configuration which is partially loaded with a quartz dielectric cylinder and show the relationships between cavity length, cavity diameter, bulb size, dielectric thickness, cavity quality factor, filling factor and cavity frequency temperature coefficient. The results are discussed in terms of improvement in maser performance resulting from particular design choices.

## INTRODUCTION

In an atomic hydrogen maser, hydrogen atoms are produced in an RF discharge source from which they emerge and pass in a beam through a magnetic state selector, with atoms in the proper hyperfine energy level passing to a quartz storage bulb mounted within a cavity resonant at the hydrogen frequency wherein maser action occurs, producing a CW output signal at the frequency of 1,420,405,751.689,3xx Hz. Figure 1 illustrates the major elements of the physical structure of masers currently constructed at Sigma Tau Standards Corporation. Several of the advantages of this general configuration were described in Reference 1. The optimization of the cavity assembly through computer analysis of the relevant maser oscillation parameters will be the primary subject of this paper.

## CAVITY DESIGN AND ELECTROMAGNETIC FIELD DIAGRAM

The cavity configuration used in the Sigma Tau hydrogen masers is illustrated in Figure 2. A copper cylinder and copper end plates form the cavity walls. A relatively thick circular cylinder of quartz is held by spring tension between the end plates, and the quartz atom storage bulb is secured to the quartz cylinder using quartz shims and hard epoxy. The quartz cylinder provides dielectric loading to reduce the outer diameter of the cavity as well as the temperature sensitivity, and at the same time provides rigid support for the bulb and a fixed spacing of the cavity end plates. The electromagnetic field mode is the TE<sub>011</sub> mode of the usual hydrogen maser active oscillator. Figure 2 also illustrates the orientation of the electric and magnetic field lines.

Figure 3 shows a diagram of the cavity and bulb assembly which is the model used for subsequent computations. The region within the inner diameter of the storage bulb is Region 1 with the dielectric constant of vacuum. In computing the filling factors, integrations of the z axis magnetic field were performed numerically over the inside volume of the bulb. Region 2, with the dielectric constant of fused quartz, includes the quartz wall of the bulb as well as the wall thickness of the quartz cylinder. The approximation is used that the quartz wall of the bulb ends is equivalent to the effect of the extra wall thickness at the ends of the cylinder, and this is a very adequate approximation since the cavity fields are relatively weak in the end regions and the bulb wall is relatively thin. Region 3, with the dielectric constant of vacuum, extends from the quartz cylinder to the copper side wall of the cavity.

## OPERATIONAL EQUATIONS OF THE HYDROGEN MASER

Reference (2) presented the basic operational equations for the hydrogen maser oscillator, and the maser equations presented herein will either be taken from or derived from that reference. By combining equations (15) and (9) of reference 2, the following equation is obtained for the relative power radiated by the hydrogen atomic beam:

$$P/P_a = 1 - I/I_{th} - 3q - 2q^2 (I/I_{th}).$$

In this equation, P is the radiated power,  $P_a$  = the power available from the beam if the maser were 100 percent efficient, I is the beam intensity (atoms/second),  $I_{th}$  is the flux required for oscillation if spin exchange could be neglected, and q is the spin exchange parameter defined in Reference (2).

Spin exchange is due to collisions between hydrogen atoms within the maser storage bulb and is the main factor which limits the possible oscillation level and line Q of the hydrogen maser. Figure 4 illustrates the severe limitation on beam utilization efficiency as the spin exchange parameter becomes large. The dependence of the spin exchange parameter on the cavity assembly configuration may be expressed (from Ref .2, Eq. 11) as:

$$q = Kl/(n'x Qc)$$

where  $K_1$  is a constant (approximately equal to 1,000),  $Q_c$  is the loaded quality factor of the cavity, and  $\nu$  is the "filling factor," which is defined as:

$$n' = \frac{V}{V_c} \frac{\langle H_z \rangle_b}{\langle H^2 \rangle_c}$$

In the foregoing equation,  $V_b$  is the bulb volume,  $V_c$  the cavity volume,  $\langle H_z \rangle_b$  is the z axis magnetic field averaged over the bulb volume and  $\langle H^2 \rangle_c$  is the average of the square of the magnetic field over the volume of the cavity.

Considering only those factors which depend on the cavity configuration,  $I_{th}$  may be expressed as:

$$I_{th} = K_2 x (\text{bulb dia.}) / (n' x Q_c).$$

Therefore both the spin exchange parameter and the flux required to oscillate depend upon the product of  $n'$  and  $Q_c$ . The loaded quality factor of the cavity,  $Q_c$ , is given by:

$$Q_c = Q_0 / (1 + P_c/P_0)$$

where  $P_c$  is the power coupled from the cavity which is available to the receiver input amplifier and  $P_0$  is the power dissipated within the cavity.

In a practical hydrogen maser oscillator it is very desirable that the coupling of the receiver to the cavity be light to reduce cavity frequency dependence on receiver impedance changes or other external environmental effects, and so  $P_c/P_0$  is typically a small fraction (of the order of .1 to .3). The above considerations indicate that it is highly desirable to maximize the product of  $n'$  and  $Q_0$  to obtain an efficient and reliable maser oscillator.

#### ELECTROMAGNETIC FIELD ANALYSIS

The electromagnetic field analysis follows conventional procedures and will not be given in detail in this paper. In outline, we start from Maxwell's equations for the curl of the electric and magnetic fields in material media and use the expressions for the curl in cylindrical coordinates. The general known solution for the electric field is expressed in terms of Bessel's functions of the first and second kinds of orders 0 and 1, and by application of appropriate boundary conditions, differentiations and integrations, several simultaneous equations are obtained which describe the electric and magnetic field coordinate components in the separate cavity regions identified in Figure 3. A computer was then programmed to obtain subroutines for the fields and the subroutines were used in further calculations to obtain the data presented in the pages which follow.

Typical results for the field analysis are illustrated by Figures 5 and 6, which show the electric and z axis magnetic fields for a cavity 12 inches long with a bulb 4.13 inches in diameter having several different thicknesses of quartz cylinder.

## $Q \times n'$ , CAVITY SIZE AND TEMPERATURE COEFFICIENT

In the curves which follow it has been assumed that the dielectric loss factor of quartz is .000,1 and the dielectric coefficient is 3.75. Also, the electrical conductivity of copper = 2.0 microhm-cm and the expansion coefficient of copper =  $1.7 \times 10^{-5}$ . The length of the bulb for the 12 inch long cavities is 9.0 inches, and the assumed shape is a straight central section with hemispherical ends. This shape is not quite optimum, but is a practical approximation which more detailed calculations show is very close to optimum. For cavity lengths other than 12 inches, the bulb length was made proportionately greater or smaller. In calculating the cavity frequency temperature coefficients, both the expansion coefficient of quartz and the variation of the dielectric coefficient of quartz with temperature have been ignored since these have a small effect compared to the thermal properties of copper.

It is interesting to observe the separate behavior of the quality factor and the filling factor as the thickness of the quartz dielectric is increased. The general form of the curves for all cases considered is exemplified by the case of the 12 inch long cavity and 4.13 inch diameter bulb shown in Figure 7. While the quality factor continuously decreases with increased dielectric loading, the filling factor rises to a peak in the range of .5 to 1.5 cm before decreasing. Therefore the use of thin-walled quartz bulbs in conventional oscillating hydrogen masers is not in general the optimum configuration to obtain the highest value of  $(n' \times Q)$ .

Figure 8 illustrates the variation of  $(Q \times n')$  and cavity radius for several different lengths of cavity and one bulb diameter. This figure shows that there is a significant improvement in these parameters with longer cavities, and also that the optimum conditions occur with a relatively thick quartz cylinder. Figures 9 through 13 show the effect of use of different diameter bulbs and different thicknesses of quartz in cavity lengths of 18, 14, 12, 10 and 8 inches.

One of the motivations for adding quartz dielectric loading to the cavity is to reduce, as much as possible, the cavity frequency temperature sensitivity. Figures 14, 15, and 16 show the cavity frequency temperature coefficient as a function of dielectric thickness for several interesting cases. Figure 14 shows the temperature coefficient for a fixed cavity length of 12 inches and three different bulb radii. For reference, a copper cavity without loading would have a temperature sensitivity of approximately 24.0 KHz/Degree C. Figure 15 shows the result for a bulb radius of 5.25 cm and two different cavity lengths, and Figure 16 shows the result for a 4.25 cm bulb and three cavity lengths.

## DISCUSSION OF RESULTS

The analysis and results presented in this paper were undertaken to optimize the hydrogen maser cavity and bulb design based upon the general configuration represented in Figures 1, 2 and 3. A primary consideration

has been that successful use of the cavity frequency switching servo technique requires very good maser output signal to noise ratio and the best possible efficiency in use of the power available in the state selected atomic hydrogen beam. It is evident that these goals can be achieved in masers with different application requirements.

For example, if small size and portability are not too important, and the highest possible line  $Q$  and smallest wall shift are desired, a large diameter bulb and long cavity would be the logical choice. As shown in Figure 9, with an 18 inch long cavity and a 6.75 cm radius bulb the best ( $Q \times n'$ ) value occurs for minimum quartz thickness. The minimum practical bulb wall is approximately .15 cm, and using a relatively thin quartz cylinder of .25 cm wall, the cavity radius would be about 12.5 cm (9.85 inch diameter cavity), and  $(Q \times n') = 27,000$ . Using a cavity coupling coefficient of .25 one would calculate from the equations previously given that the spin exchange parameter  $q = .046$ . This would be a very efficient maser oscillator, and with the exception of the high  $Q$  copper cavity is very similar in size and bulb volume to masers constructed in the past at NASA, Goddard Space Flight Center (3).

To make somewhat smaller size masers without compromising efficiency or stability significantly, one might choose a 12 inch long cavity. It is seen in Figure 8 that the improvement in ( $Q \times n'$ ) is not great when increasing the length beyond 12 inches. For a 5.25 cm radius bulb (4.13 inches diameter) and .5 cm dielectric thickness, the resultant cavity radius would be about 12.2 cm (9.6 inches diameter) and the calculated spin exchange parameter with .33 cavity coupling is .039; these are the dimensions and parameters for the masers reported in Reference 1. These masers have extremely good efficiency, and are the first hydrogen masers to successfully use the cavity frequency switching servo technique to control cavity pulling. As cavities shorter than 12 inches are chosen, there is an increasing penalty in both ( $Q \times n'$ ) and cavity diameter. For the larger bulb sizes in short cavities the maser becomes less efficient, and if the cavity wall material has a realized electrical conductivity much less than that of copper, a very borderline oscillator will result.

The use of copper as the cavity wall material has important advantages from several points of view. In addition to good electrical conductivity, giving high cavity  $Q$ , it has high specific heat which results in relatively large thermal mass. Systematic thermal perturbations are a most important consideration in attempts to improve stability for measuring intervals of about 1,000 seconds and longer, and the large thermal capacitance reduces the rate at which the cavity frequency can change, and also relaxes the required response time of thermal control systems or automatic cavity tuners.

The cavity frequency temperature coefficients illustrated in Figures 14, 15 and 16 are relatively low in comparison to an unloaded metal cavity. In practice, the average cavity frequency is controlled in our present designs by changing the temperature; this has the advantage of a relatively wide, linear and smooth cavity frequency control range, and the cavity, coupling loop, and cavity frequency switching varactor are automatically held at constant temperature by the control servo. If the cavity were made of a low expansion material such as silvered fused silica, it would be necessary

to control the average cavity frequency with a varactor; not only would this result in a non-linear and narrow frequency control range, it would introduce the possibility of changing the cavity Q's or receiver coupling coefficient when modulating the cavity frequency. So the use of a metal cavity with the cavity frequency switching servo is strongly indicated, and the temperature dependence shown by the figures is well suited to the requirements of cavity tuning.

## CONCLUSION

The results presented in this paper provide guidelines for the design of cavity and bulb assemblies for hydrogen masers in an optimal fashion which are well adapted to use of the cavity frequency switching servo technique, as well as information which should be of more general interest for consideration of alternative maser cavity assembly design approaches. The two hydrogen masers described in Reference 1 were the first masers constructed using the new configuration. These masers also demonstrated the first use of the cavity frequency switching servo, and the stability results obtained show that unprecedented stability as well as the other advantages discussed in this paper can be realized. An example of the long term stability obtained in recent maser comparisons is illustrated in Figure 17. This figure shows the fractional frequency change for a thirty day period between the two hydrogen masers described in Reference 1. The slope of the frequency differences over this period is  $5.8 \times 10^{-16}$  per day, so the effect of drift on the daily frequency fluctuations is negligible. Figure 18 shows the measured stability in a "Sigma Tau" plot using the two sample "Alan Variance" for intervals from one second to ten days. There has been no drift term removed, nor other modifications made to the data.

## ACKNOWLEDGEMENTS

The authors gratefully acknowledge the interest and support of the following organizations in this work: The Naval Research Laboratory, The Applied Physics Laboratory of The Johns Hopkins University, and NASA, Goddard Space Flight Center. (APL Contract No. 601748-S, NRL Contract No. N00014-83-C-2015.)

## REFERENCES

1. H. E. Peters, "Design and Performance of New Hydrogen Masers Using Cavity Frequency Switching Servos," Proceedings, 38th Annual Symposium on Frequency Control, 1984.
2. D. Kleppner, et al. "Hydrogen Maser Principles And Techniques," Phys. Rev., Vol. 138, No. 4A, A972-A983, 17 May, 1965.
3. Victor S. Reinhardt, et al. "NASA Atomic Hydrogen Standards Program - An Update," Proceedings, 30th Annual Symposium on Frequency Control, 1976.

ORIGINAL PAGE IS  
OF POOR QUALITY

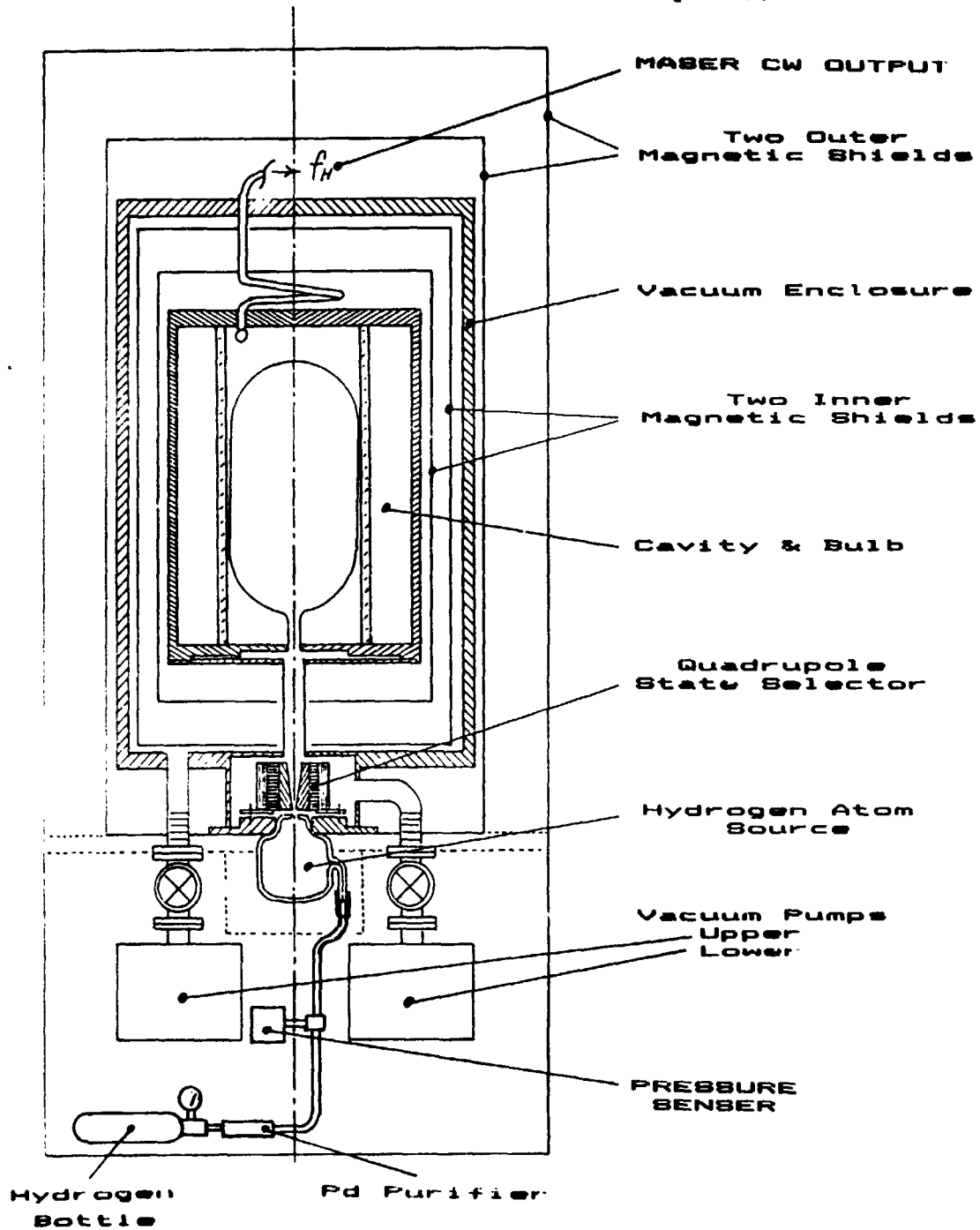

HYDROGEN MASER PHYSICAL ASSEMBLY

Figure 1.

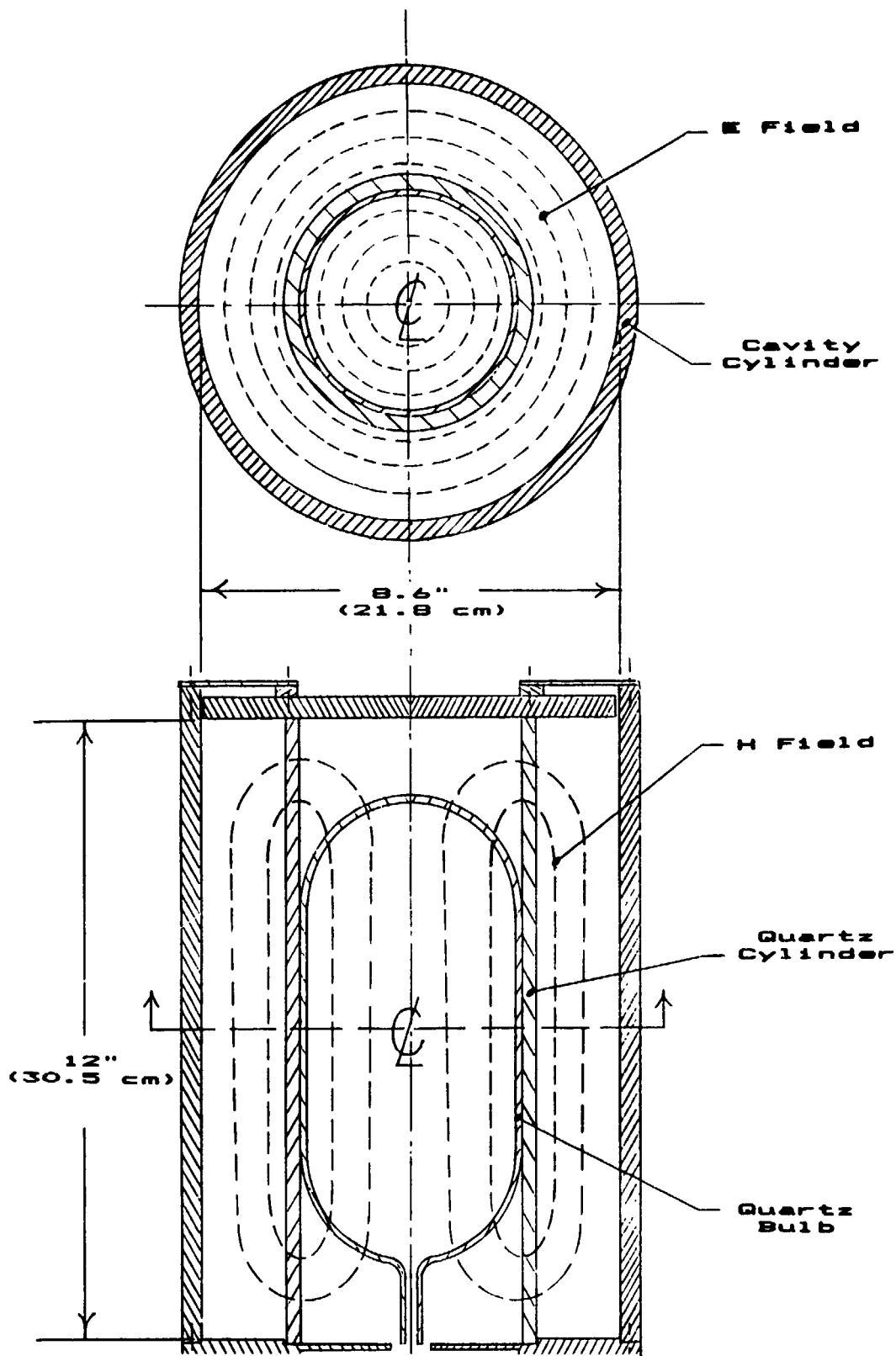

**HYDROGEN MASER CAVITY**  
**Figure 2.**



ORIGINAL PAGE IS  
OF POOR QUALITY

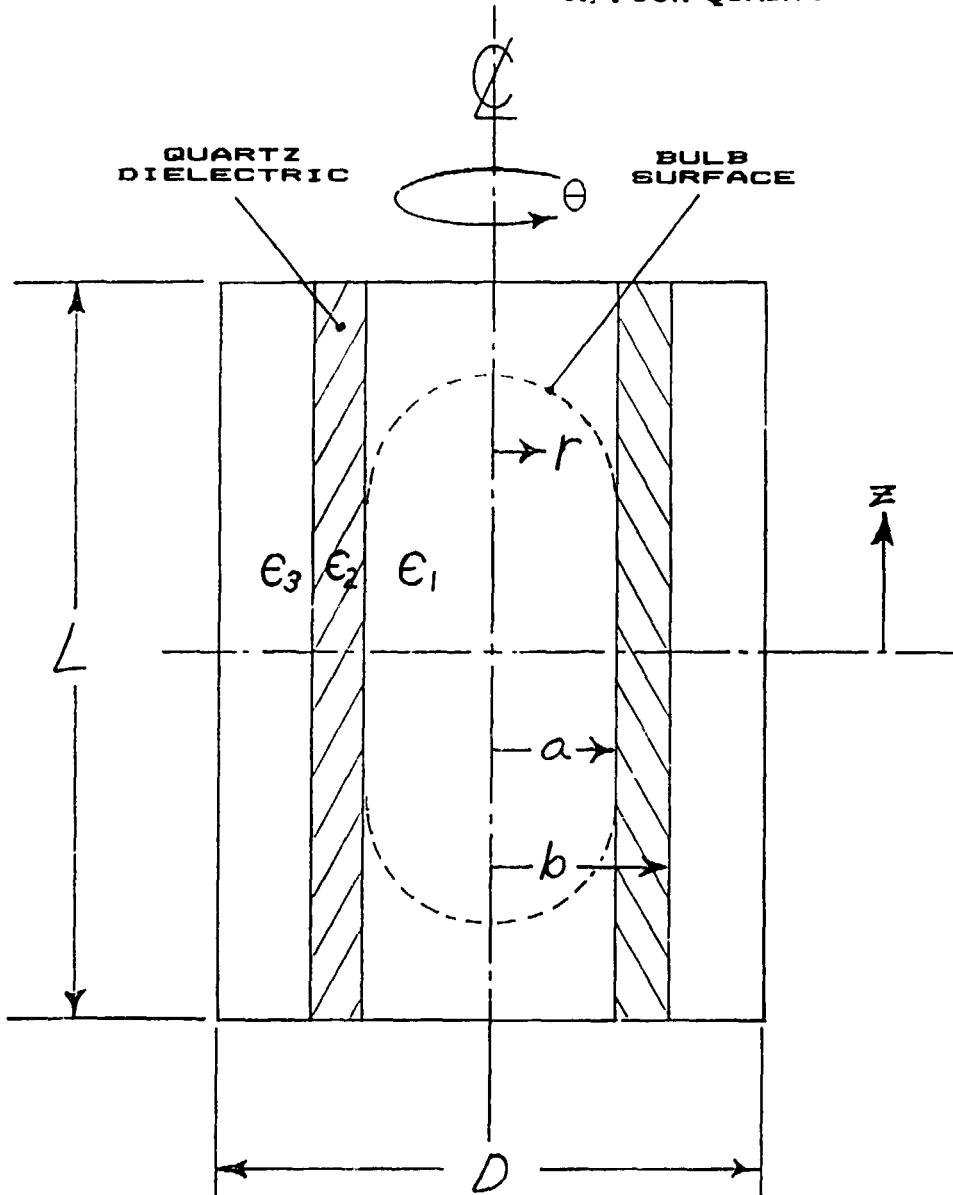

CAVITY ANALYSIS MODEL

Figure 3.

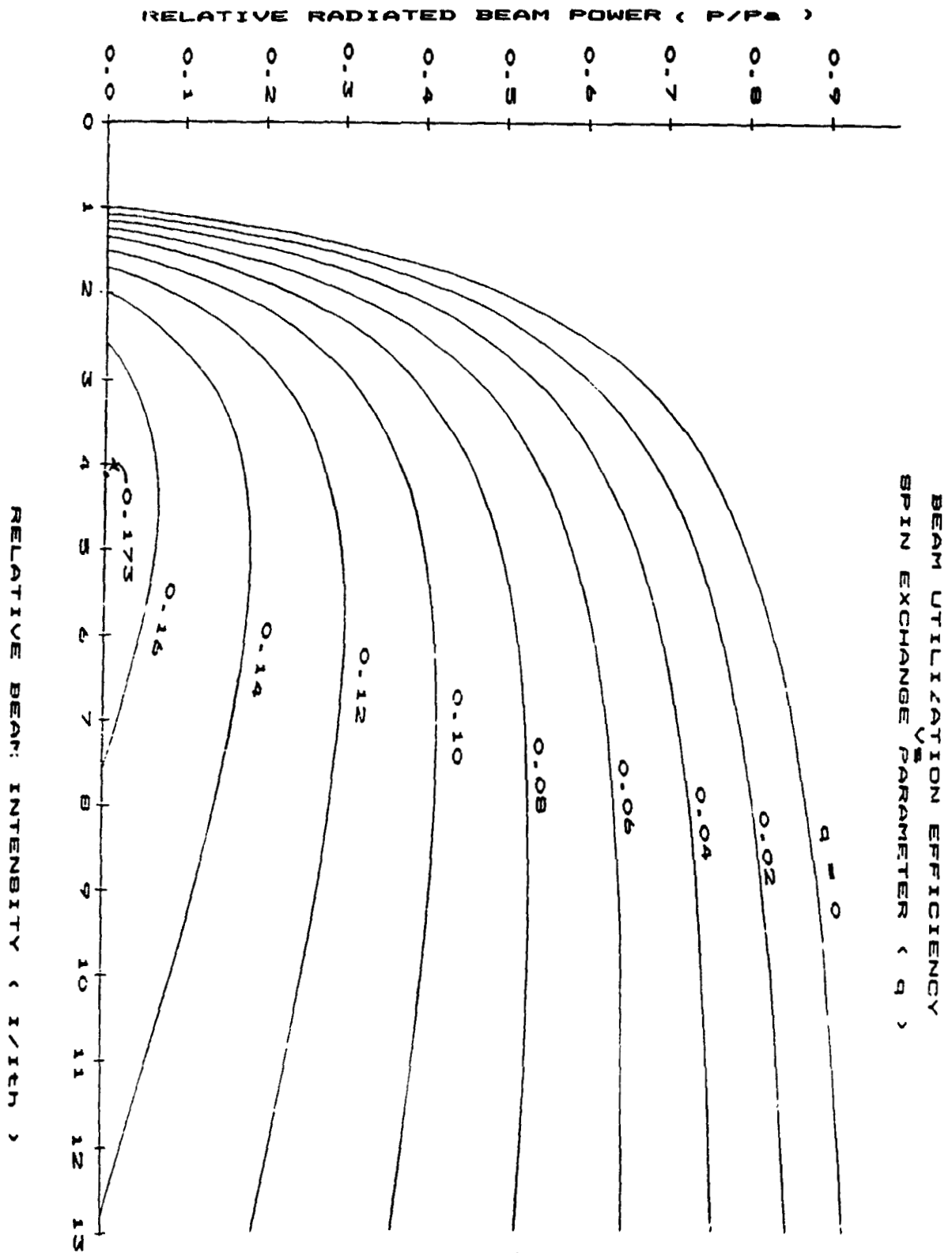

Figure 4.

ORIGINAL PAGE IS  
OF POOR QUALITY

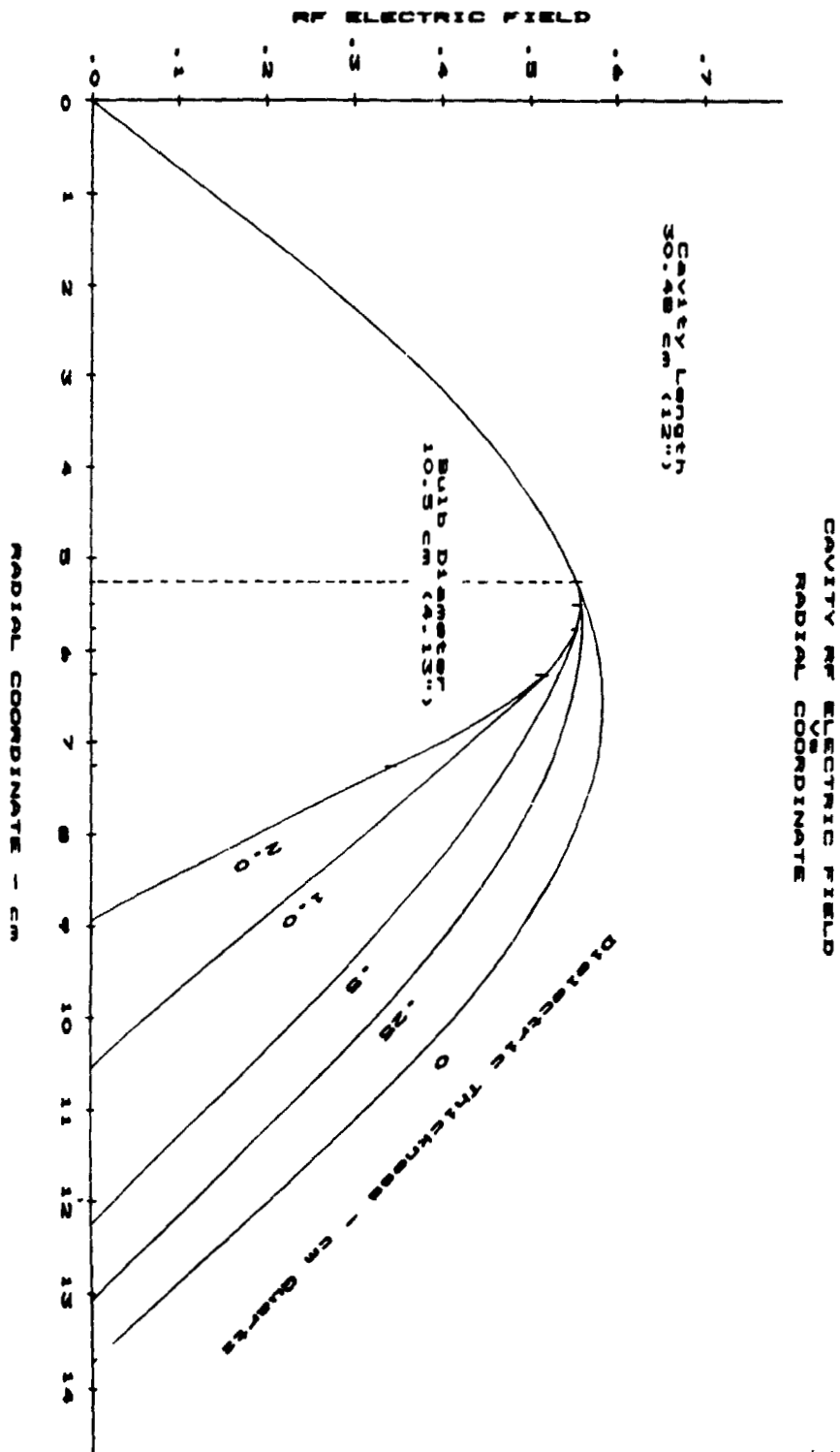

Figure 5.

ORIGINAL PAGE IS  
OF POOR QUALITY

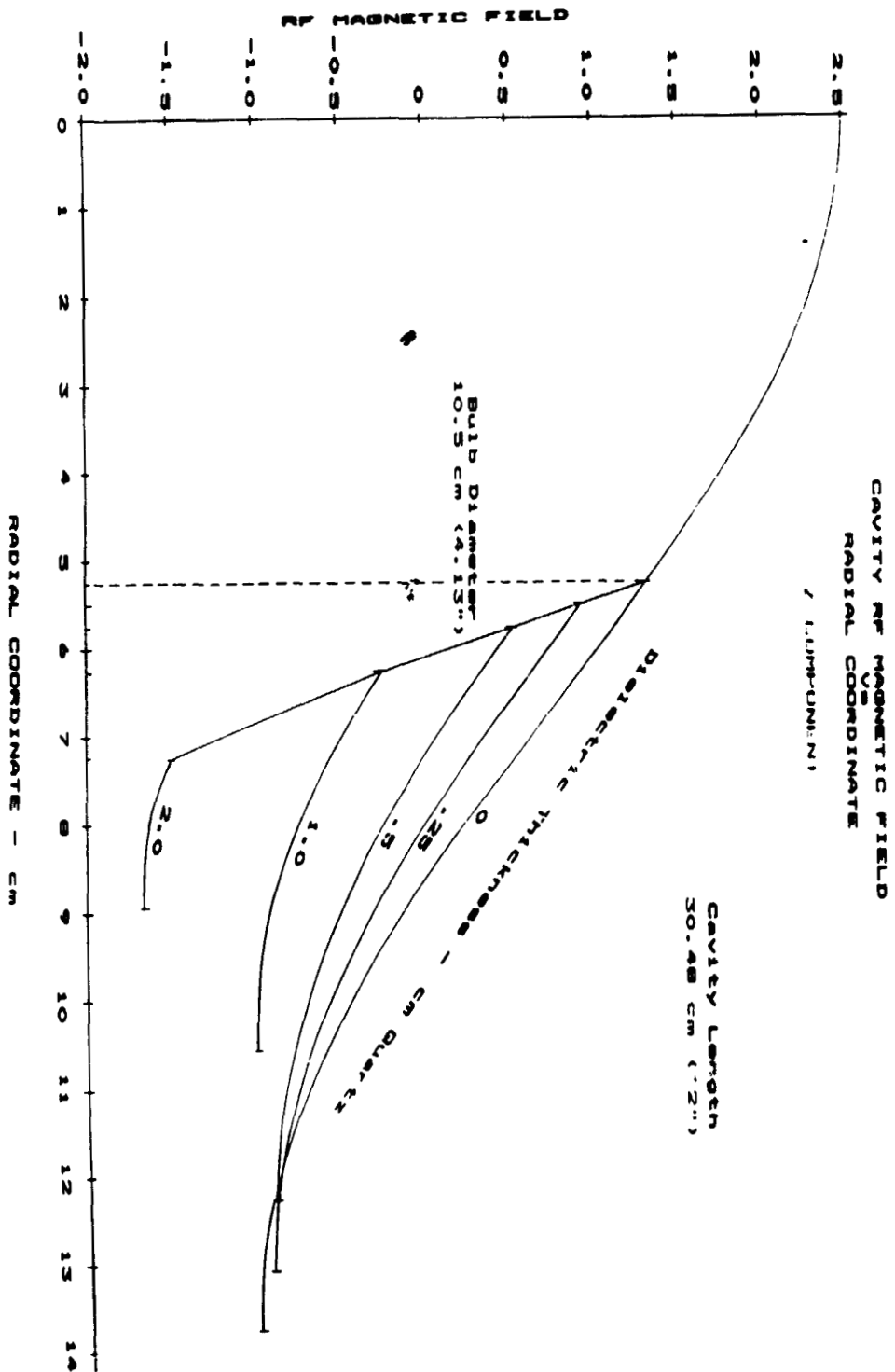

Figure 6.

ORIGINAL PAGE IS  
OF POOR QUALITY

THIS PAGE IS  
 UNCLASSIFIED

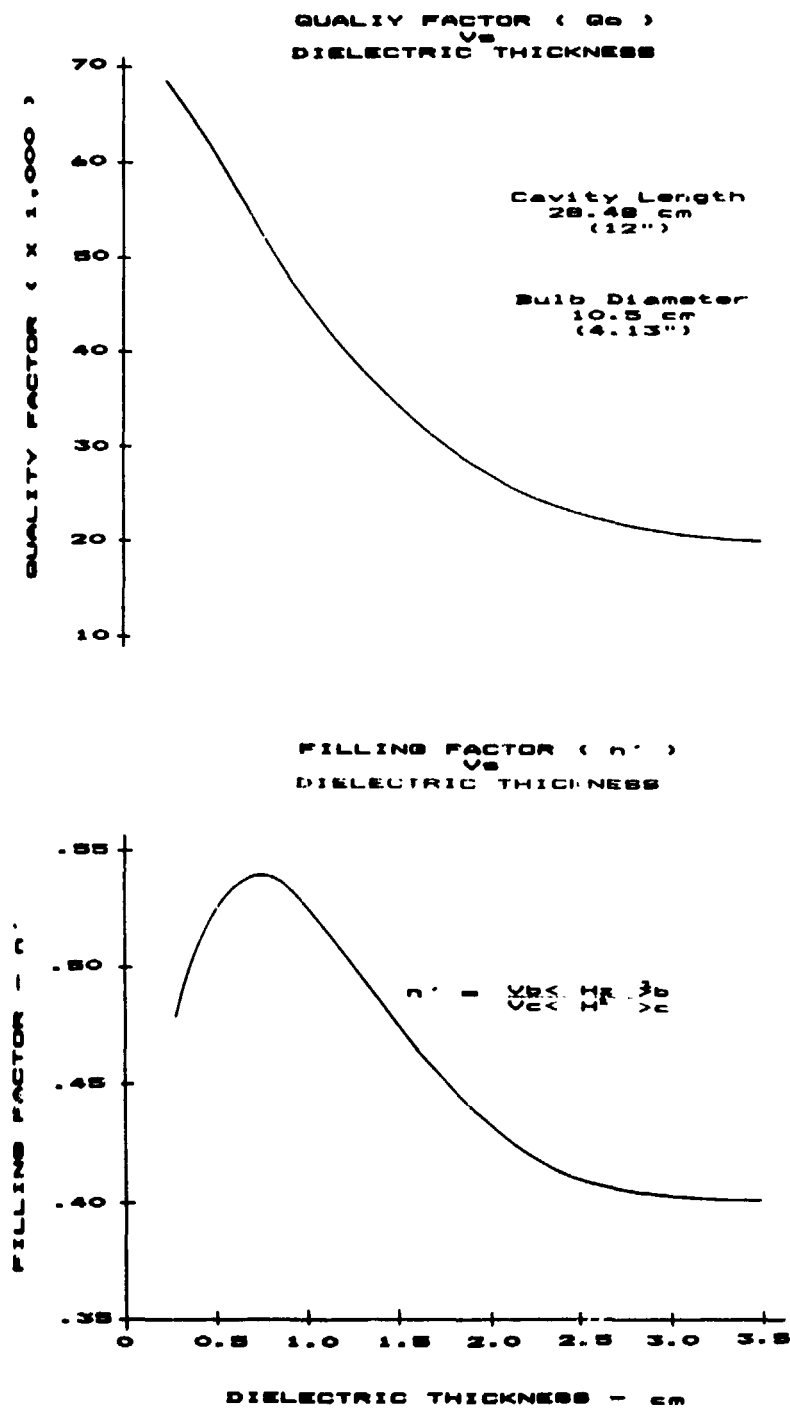

Figure 7.

QUALITY FACTOR & FILLING FACTOR  
OF POOR QUALITY

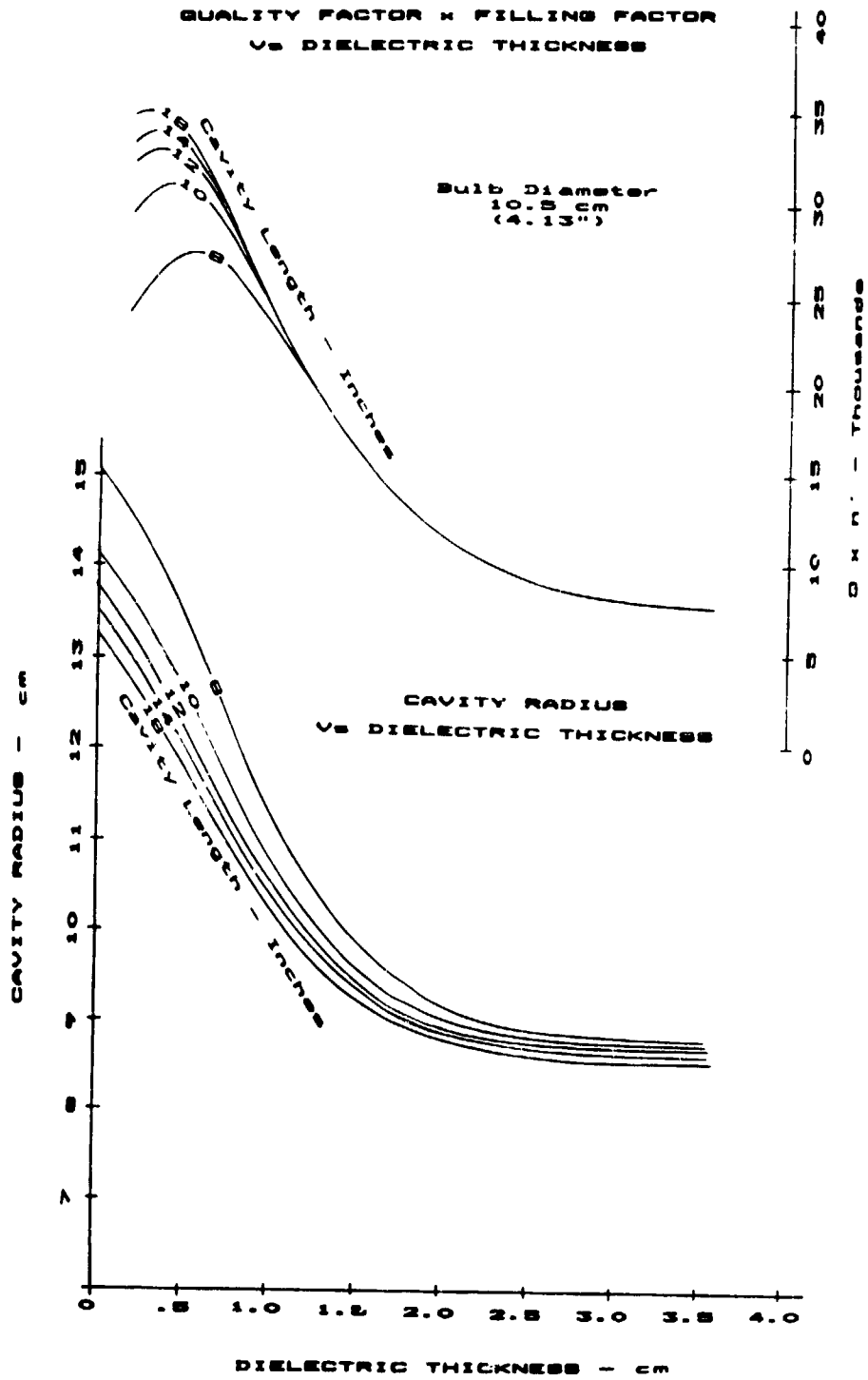

Figure 8.

QUALITY FACTOR x FILLING FACTOR  
 VS DIELECTRIC THICKNESS

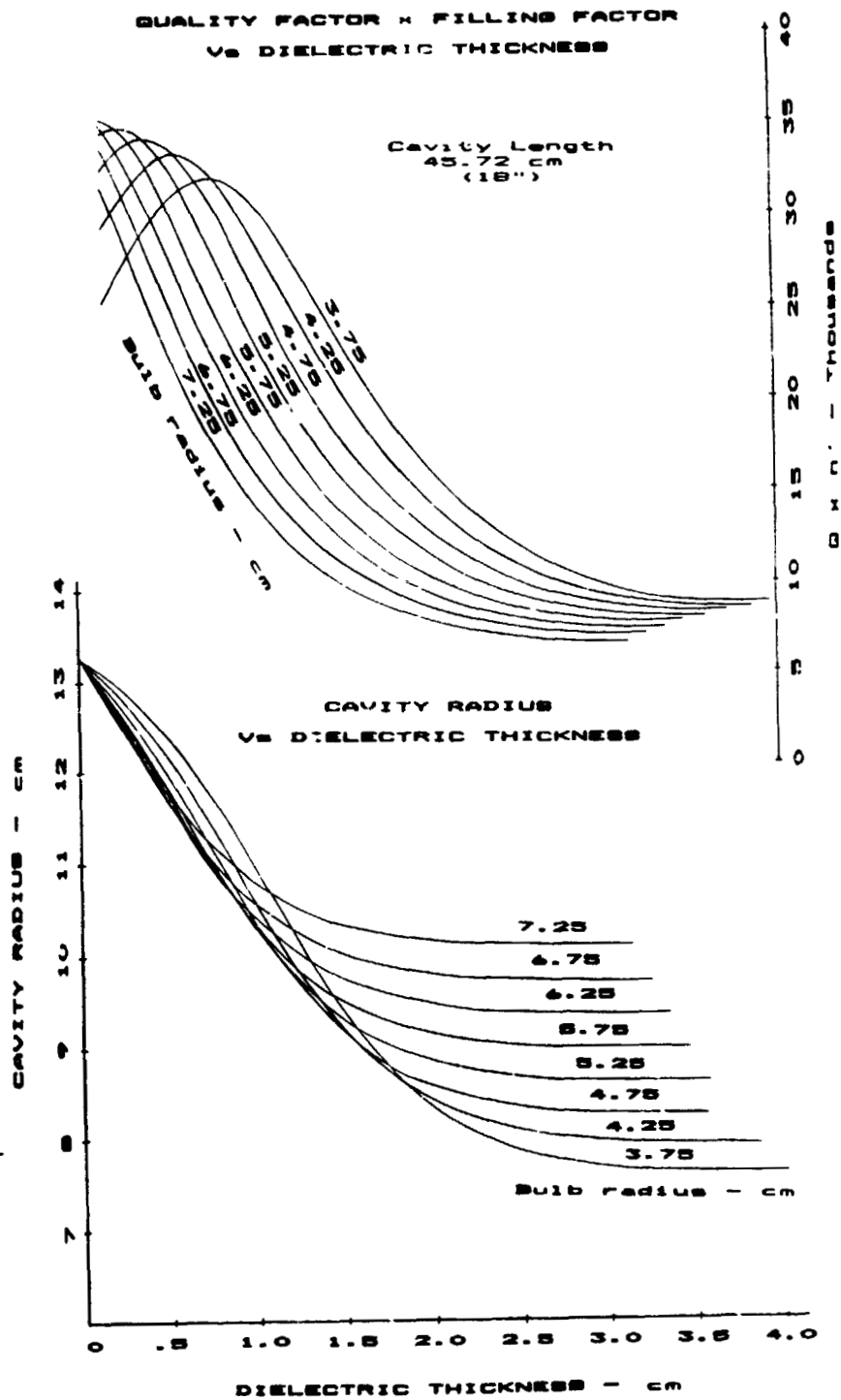

Figure 9.

ORIGINAL PAPER  
OF POOR QUALITY

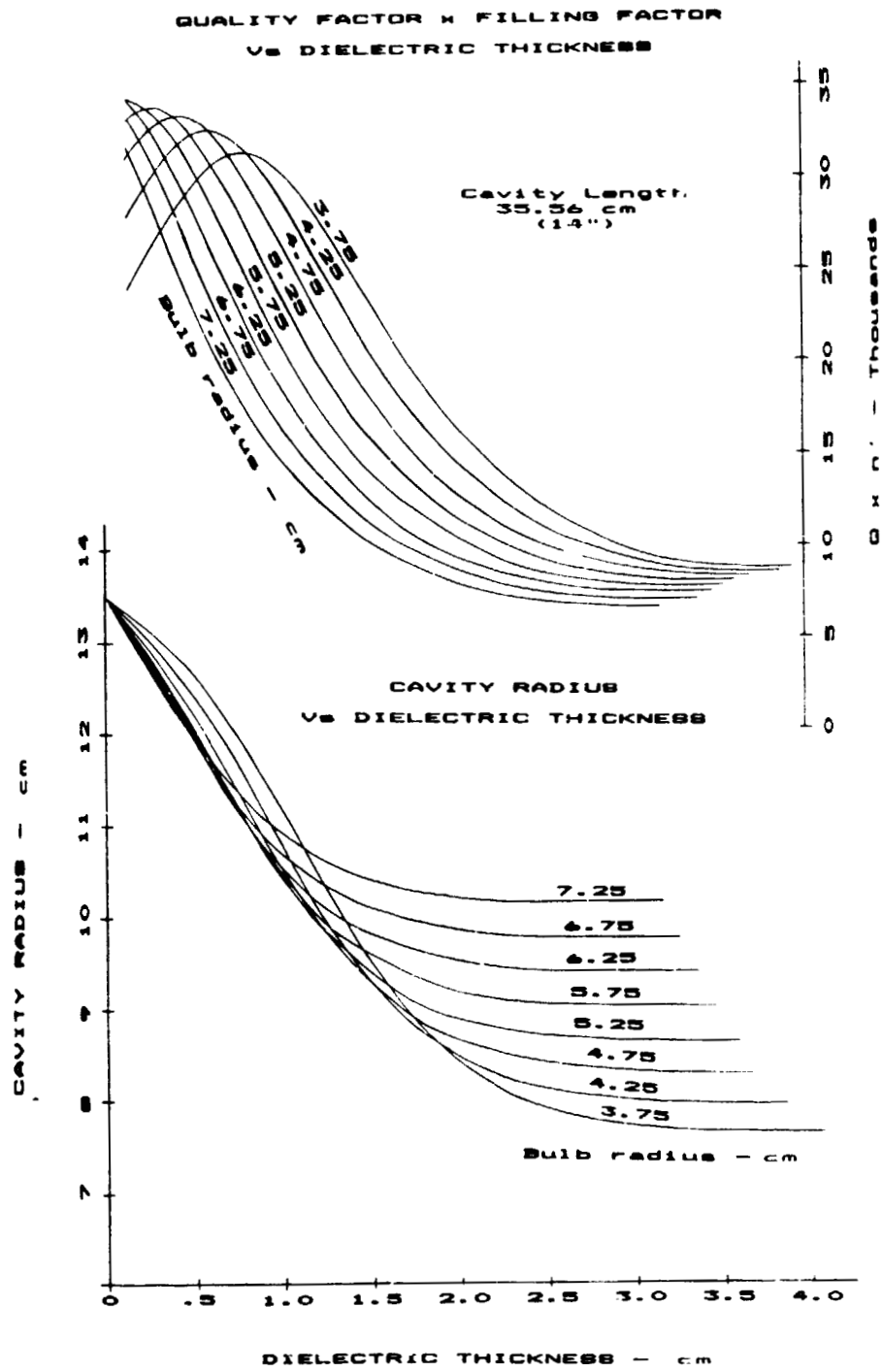

Figure 10.



ORIGINAL PLAN  
OF POOR QUALITY

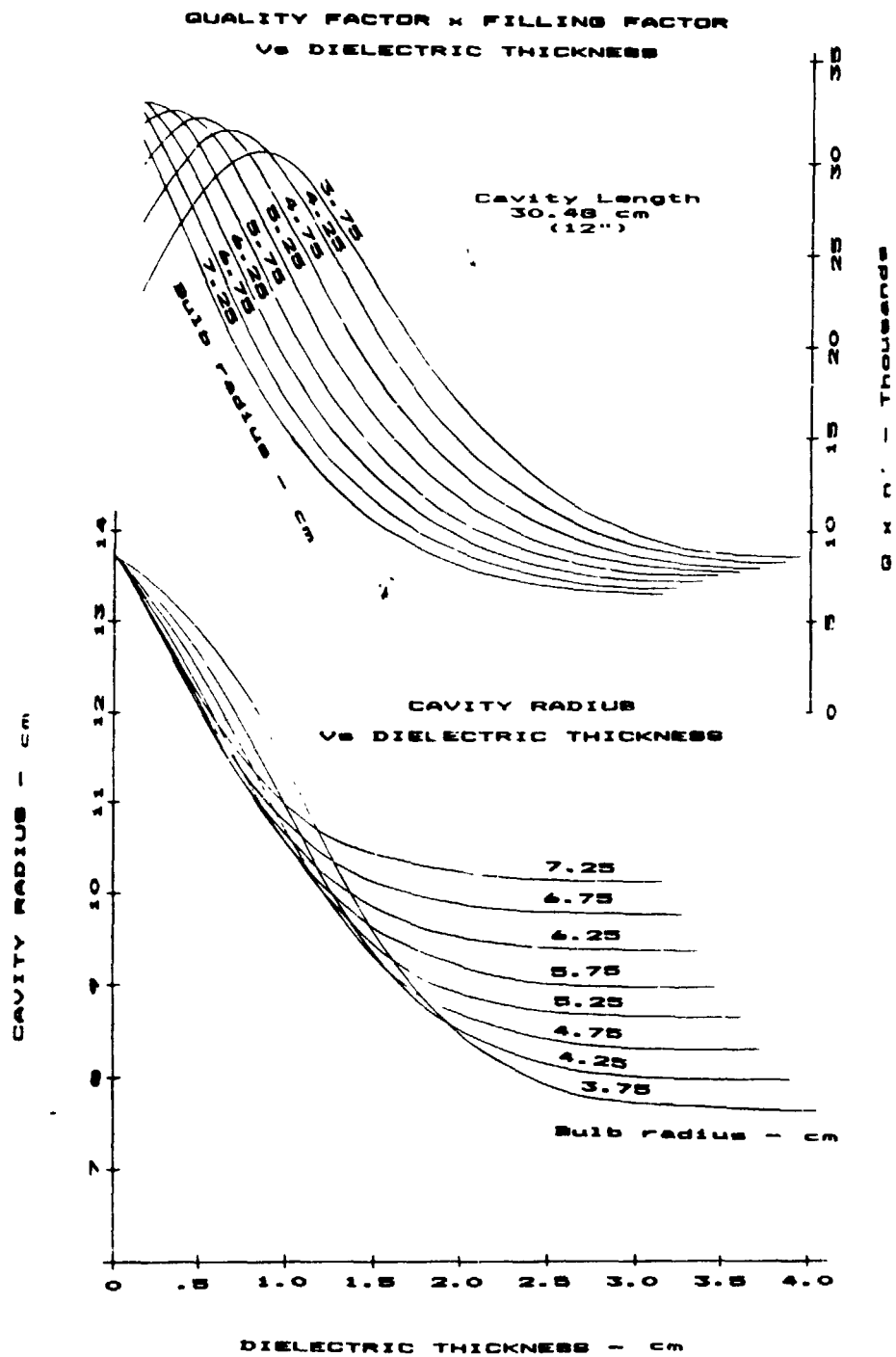

Figure 11.

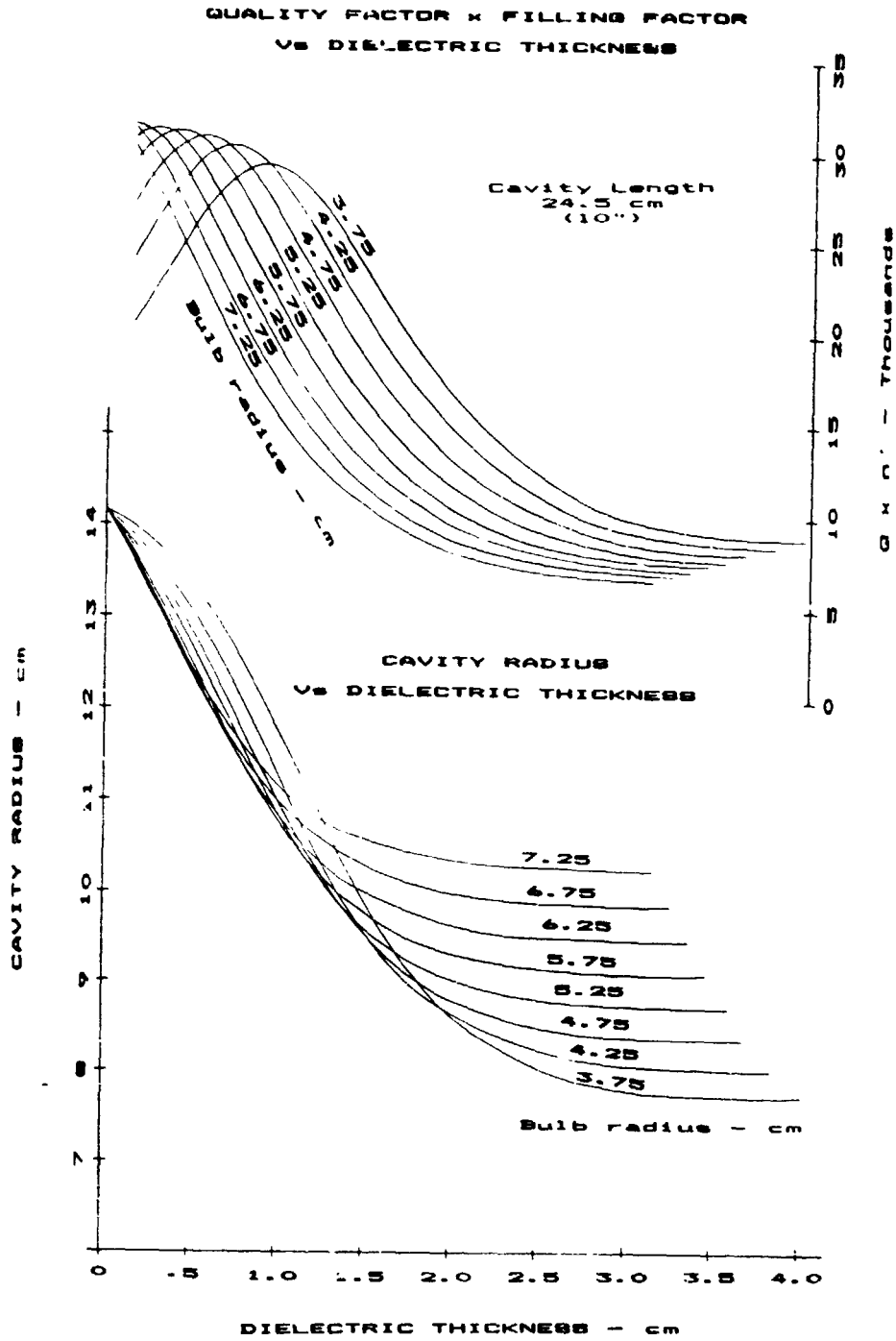

Figure 12.

ORIGINAL SOURCE  
OF POOR QUALITY

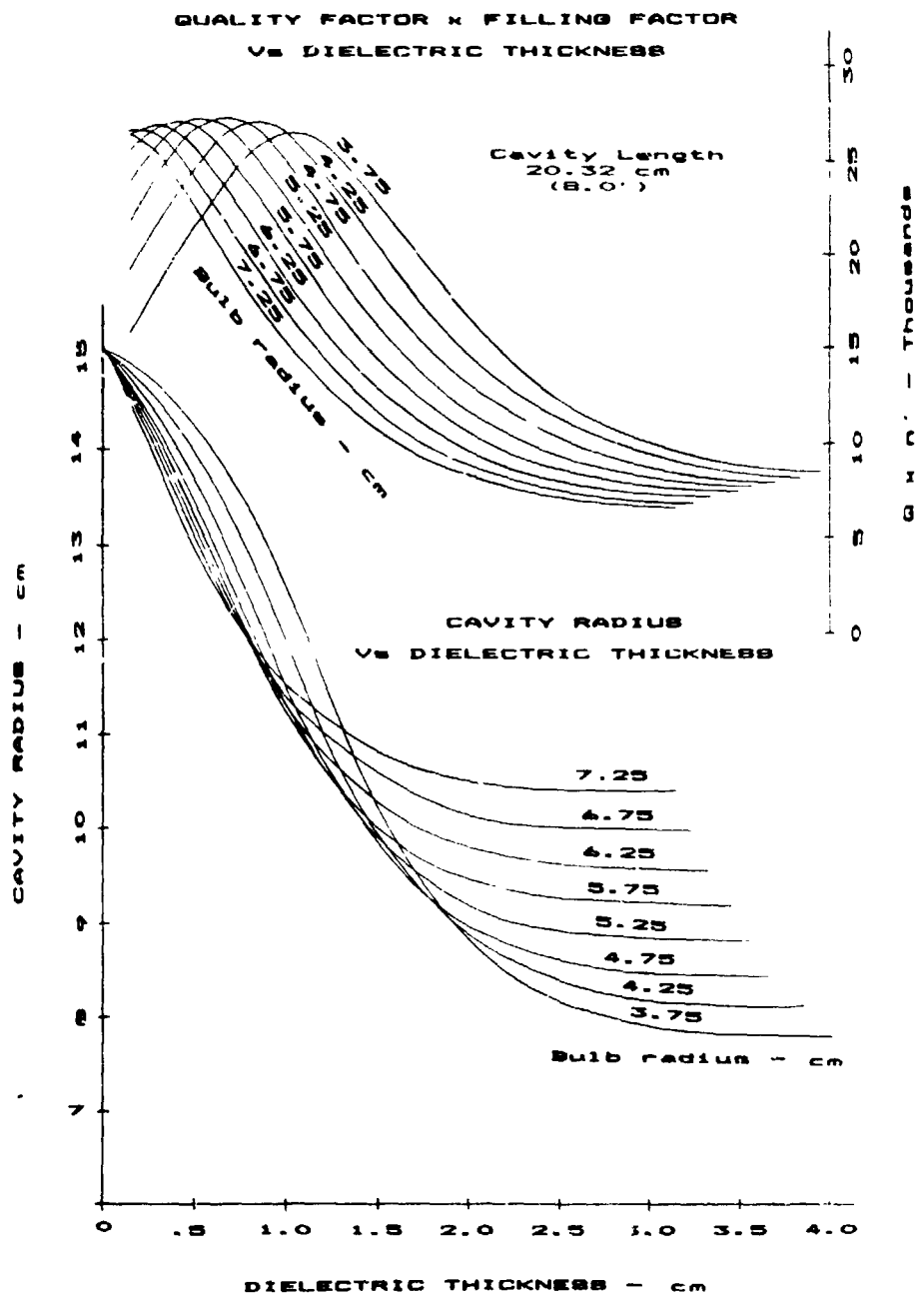

Figure 13.

ORIGINAL PAGES  
OF POOR QUALITY

TEMPERATURE COEFFICIENT  
vs  
DIELECTRIC THICKNESS

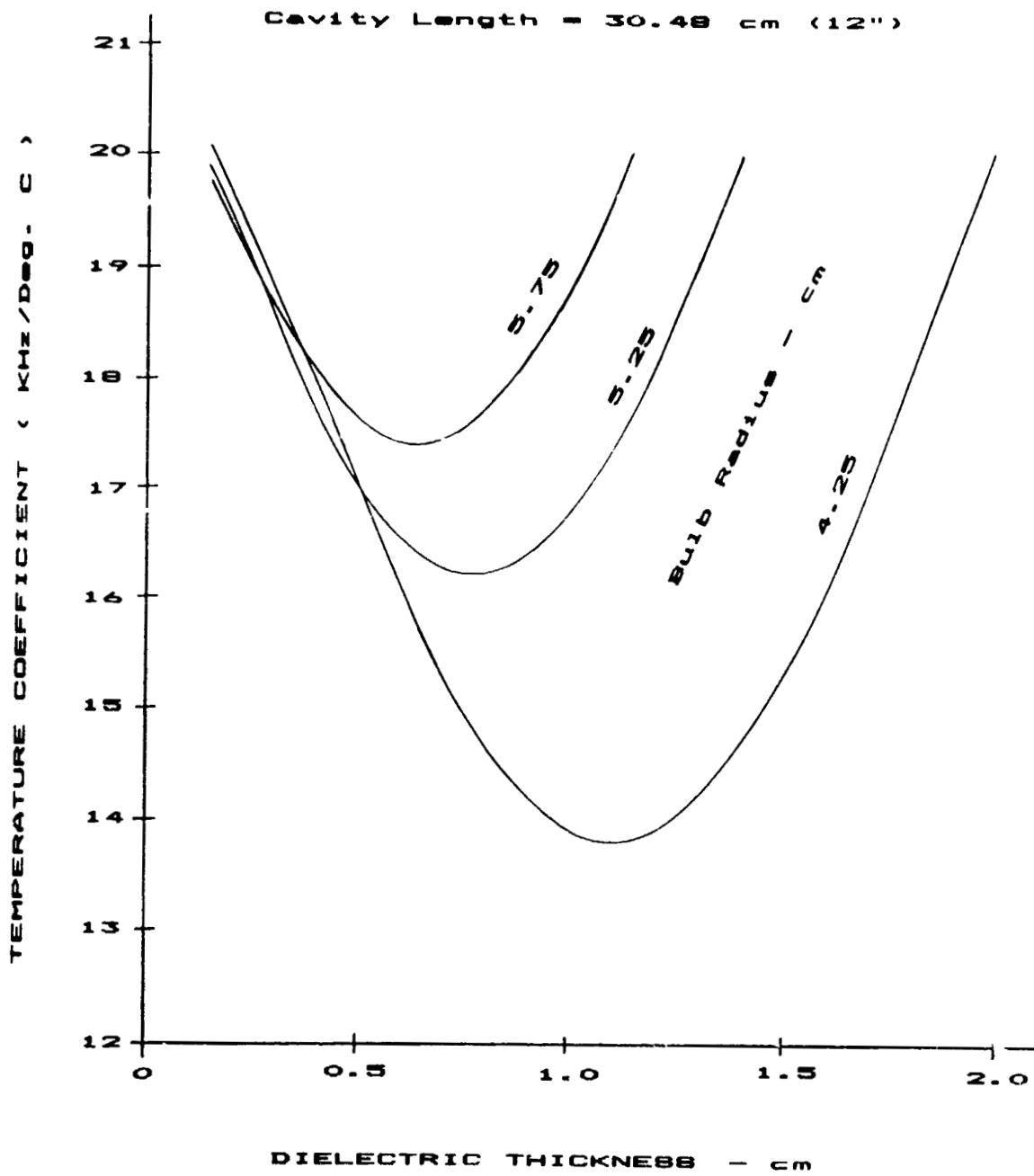

Figure 14.

ORIGINAL COPY  
OF POOR QUALITY

TEMPERATURE COEFFICIENT  
DIELECTRIC THICKNESS

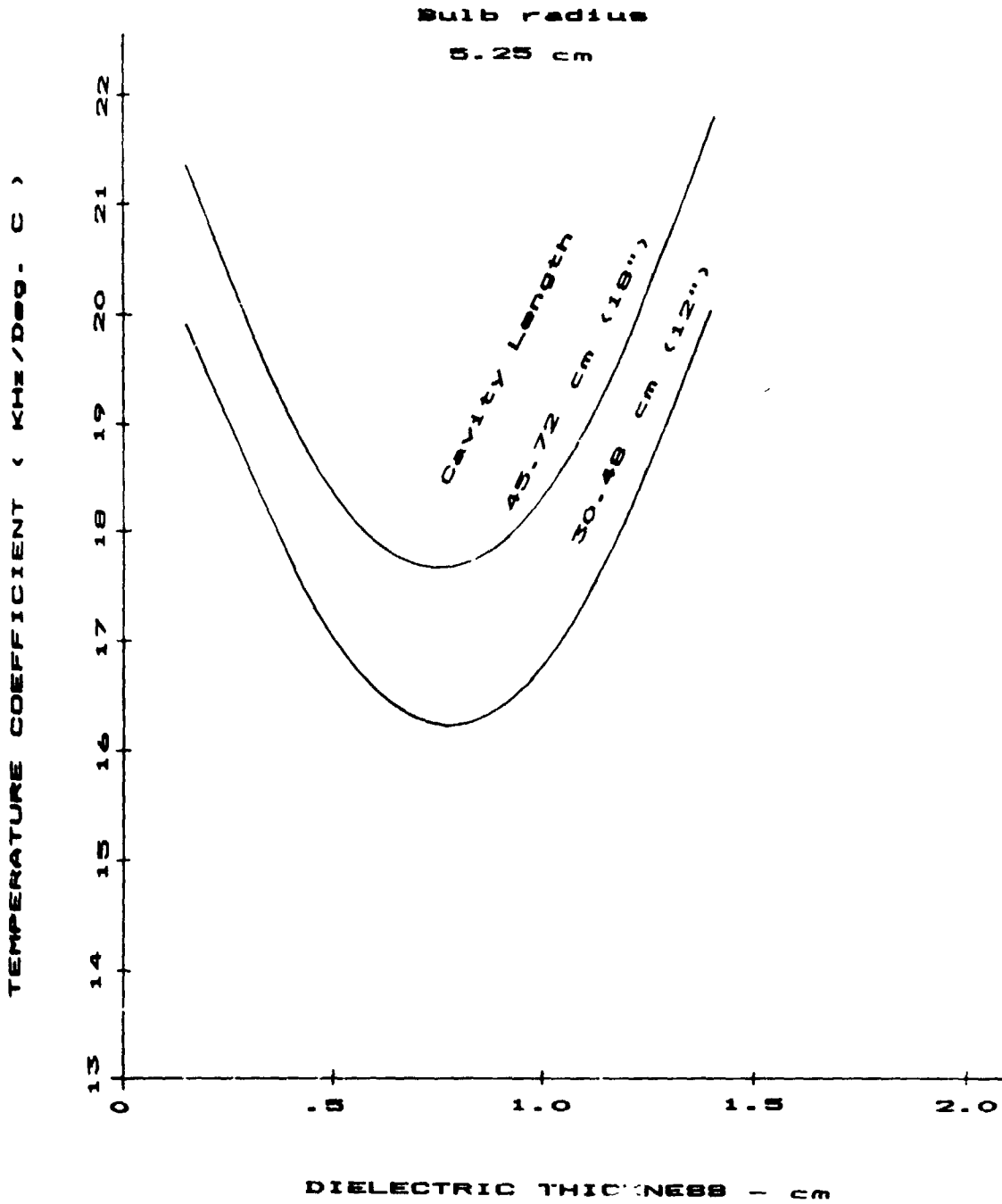

Figure 15.

TEMPERATURE COEFFICIENT  
vs  
DIELECTRIC THICKNESS

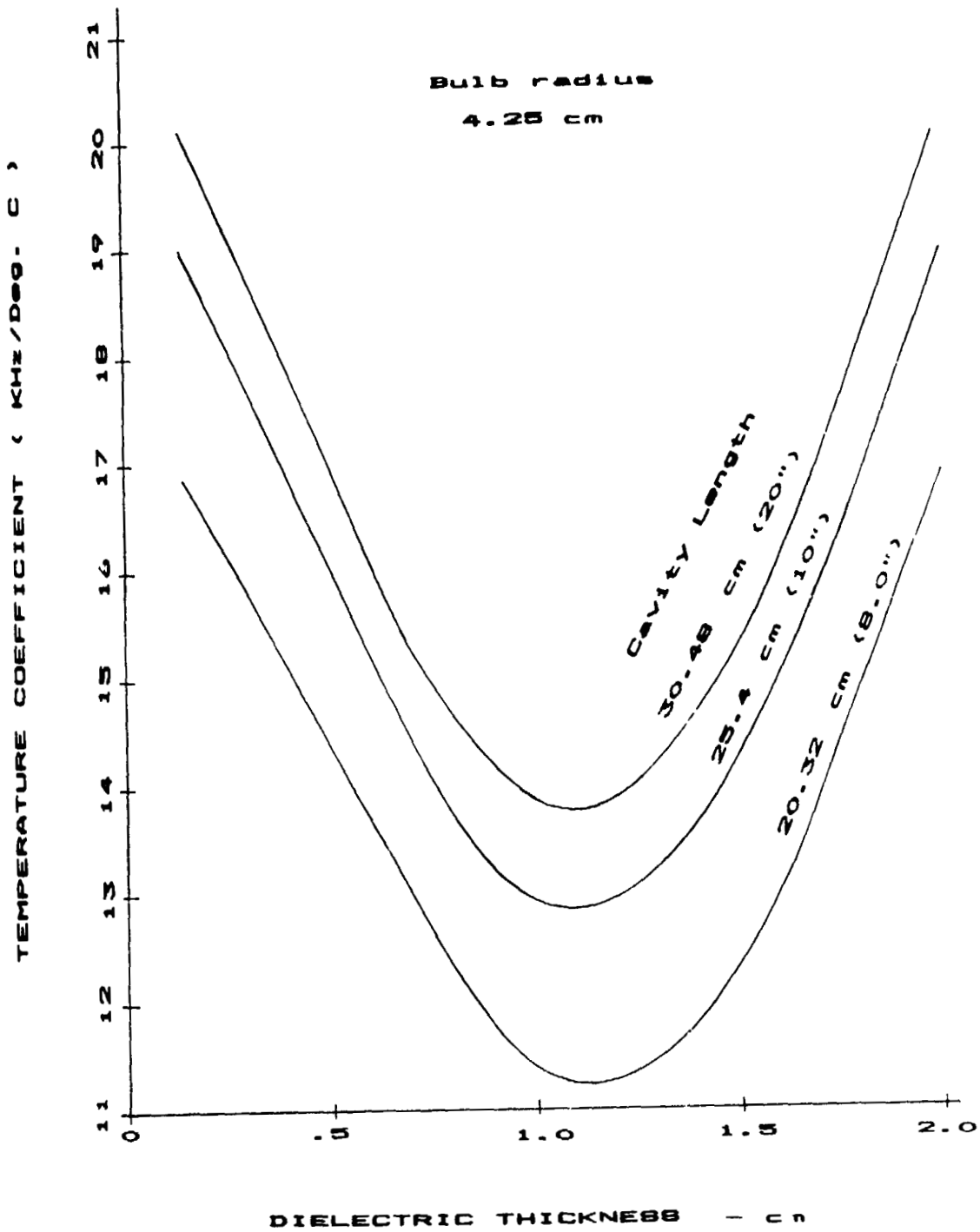

Figure 16.

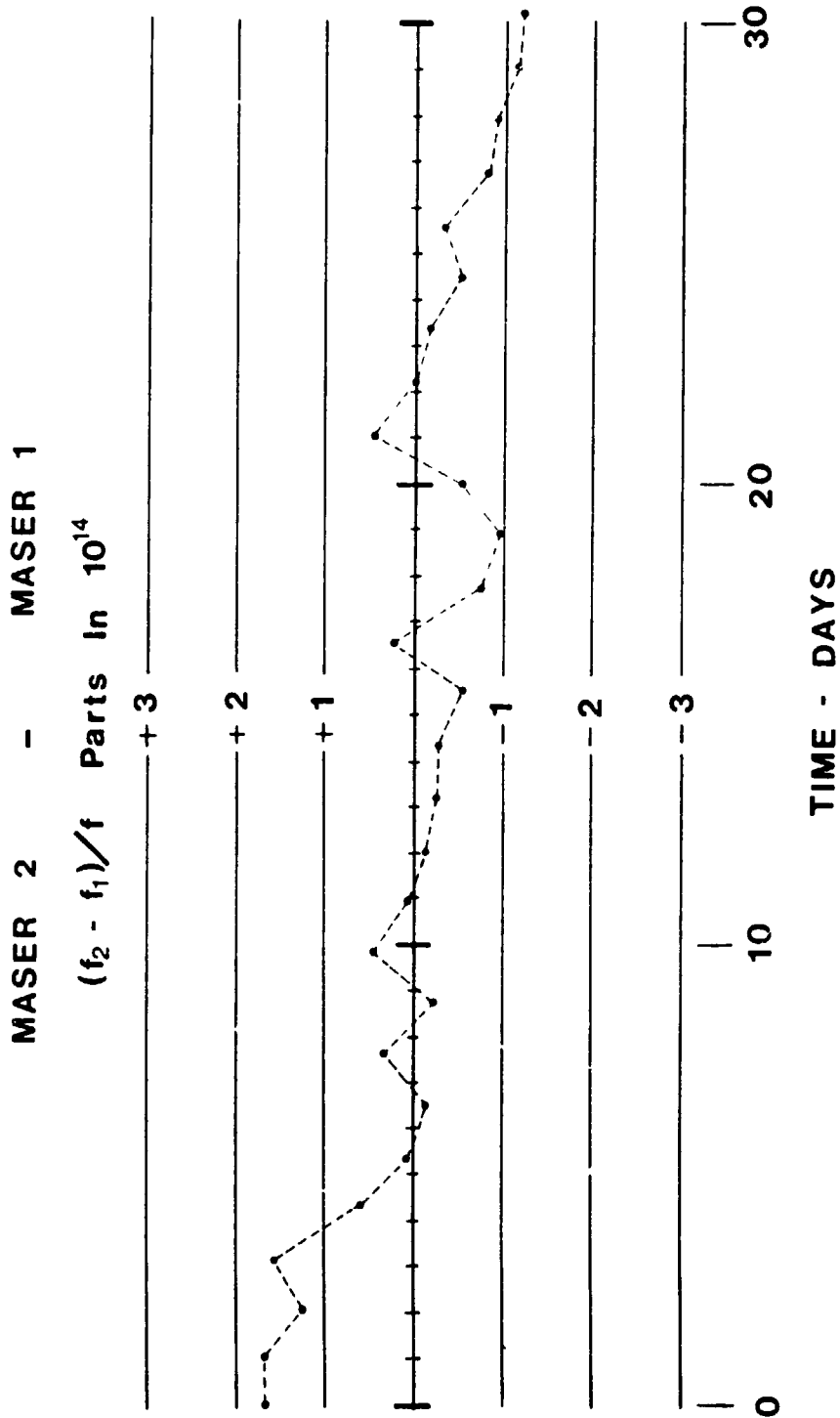

Figure 17.

ORIGINAL PAGE IS  
OF POOR QUALITY

# HYDROGEN MASER STABILITY

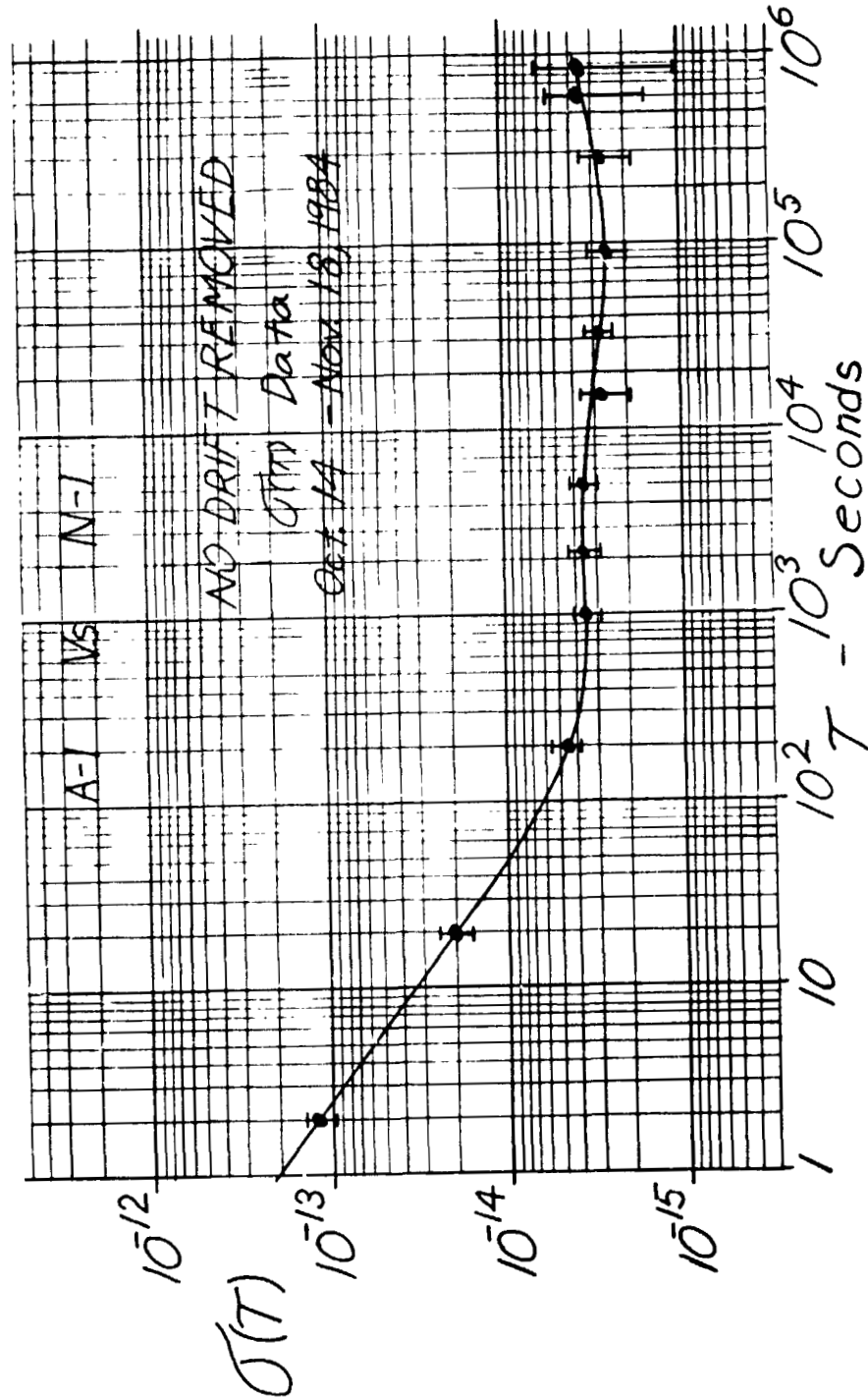

Figure 18.



## QUESTIONS AND ANSWERS

JACQUES VANIER, NATIONAL RESEARCH COUNCIL: In your proposed design, would it not be simpler to remove the bulb and use the dielectric loading as a bulb itself?

MR. PETERS: Yes, that's very conceivable. I have been thinking of getting pieces of quartz ground out.

MR. VANIER: But there is no purpose for the bulb at the present time?

MR. PETERS: I haven't analyzed it completely, but I think that you need to improve the filling factor a little more by filling in the top section slightly.

STUART CRAMPTON, WILLIAMS COLLEGE: I would like to say that the last is not true when you take into account the way in which you are changing the volume of the bottle. You are better off than having those ground pieces.

MR. VANIER: You wouldn't increase the filling factor.

MR. PETERS: I think that even if you increase the bulb to the full length, that should be filled in with quartz, not make the bulb the full length of the cavity.

MR. VANIER: I see. But my question is this: You would gain in simplicity by removing the bulb completely, and use up to the end as a bulb. You would lose a little in filling factor, but so what?

MR. PETERS: You could lose something else very important though, the facility with which you could coat the bulb in a nice, clean, dependable way.

ALBERT KIRK, JET PROPULSION LABORATORY: Can you tell me the aging rate of the cavities before you apply the thermal corrections?

MR. PETERS: These are relatively unstable cavities. They are a thin wall of copper on the outside, compared to a much more thermally massive cavity. But they are still fairly respectable in that respect. One of them is going at about two to three parts in ten to the fourteen per day and the other one is about seven parts in ten to the fourteen per day.

However, we tune continuously. All the stability data is taken with the autotuner system working, and there is no degradation in either the short term or the long term stability if you leave the cavity servo on. The cavity servo is really a thermal control system, so in that sense they don't drift.

MR. KIRK: What is the time constant of the servo system?

MR. PETERS: It's just about fast enough to come in where thermal perturbations start to become important. That is between one

thousand and ten thousand seconds.

MR. MCCOUBREY: If I followed your discussion, you indicated that the long narrow cavity was advantageous with respect to the cavity Q and filling factor. Did you also consider the effect of the declining effectiveness of the magnetic shields that you put around all of this? The long narrow shields are less effective.

MR. PETERS: I think that they are more effective. The larger cavity diameter and the larger shield are shorter, and it's mostly the axial field that gives you trouble. The transverse shielding factor hardly ever gives any effect in measurement. The longer and narrower shield gives more space on the ends than we had in the past, so you get a better shielding factor with a small diameter and also more space for thermal insulation, and vacuum and things like that.

MR. ALLAN: Is the last data point on your sigma-tau plot ten days?

MR. PETERS: I stopped it at ten days. It was only thirty days worth of data.