

NASA  
Reference  
Publication  
1135

September 1985

# Energy Efficient Transport Technology

*Program Summary and Bibliography*

David B. Middleton,  
Dennis W. Bartlett,  
and Ray V. Hood

NASA

NASA  
Reference  
Publication  
1135

1985

# Energy Efficient Transport Technology

*Program Summary and Bibliography*

David B. Middleton,  
Dennis W. Bartlett,  
and Ray V. Hood

*Langley Research Center  
Hampton, Virginia*



National Aeronautics  
and Space Administration

Scientific and Technical  
Information Branch



# CONTENTS

SYMBOLS AND ABBREVIATIONS . . . . .	v
SUMMARY . . . . .	1
INTRODUCTION . . . . .	1
DESCRIPTION OF RESEARCH AND RESULTS . . . . .	2
Advanced Aerodynamics . . . . .	2
High-Aspect-Ratio Supercritical-Wing Technology . . . . .	2
Winglets . . . . .	5
Nacelle Aerodynamic and Inertial Loads (NAIL) . . . . .	6
Aircraft Surface Coatings . . . . .	7
Laminar Flow Research . . . . .	8
Computational Aerodynamics . . . . .	8
Active Controls Technology (ACT) . . . . .	8
Control of Aeroelastic Responses . . . . .	9
Pitch Stability Augmentation . . . . .	9
Integrated Application of Active Controls (IAAC) . . . . .	11
Fault-Tolerant Systems . . . . .	14
Interdisciplinary Technology Applications . . . . .	14
Additional EET Studies . . . . .	16
IEM Study . . . . .	16
Longitudinal Handling Qualities . . . . .	16
CONCLUDING REMARKS . . . . .	16
REFERENCES . . . . .	17
APPENDIX—BIBLIOGRAPHY OF EET REPORTS . . . . .	20
Program Overviews . . . . .	20
Boeing Programs . . . . .	21
Douglas Programs . . . . .	22
Lockheed Programs . . . . .	23
Government Publications . . . . .	23
Advanced Aerodynamics . . . . .	23
Computational Aerodynamics . . . . .	27
Active and Highly Reliable Controls . . . . .	27
Contractor Publications . . . . .	29
Advanced Aerodynamics . . . . .	29
Active Controls . . . . .	37
Handling Qualities . . . . .	48
Interdisciplinary Technology Applications . . . . .	49



## SYMBOLS AND ABBREVIATIONS

AAL	angle-of-attack limiting	$R_{(L/D)}$	relative $L/D$ (i.e., $L/D$ of supercritical wing at $C_L = 0.6$ relative to $L/D$ of conventional wing at $C_L = 0.45$ )
ACEE	Aircraft Energy Efficiency	$M$	Mach number
ACT	active controls technology	mac	mean aerodynamic chord
AR	aspect ratio	MLC	maneuver load control
ARW	aeroelastic research wing	NAIL	Nacelle Aerodynamic and Inertial Loads
ATC	air traffic control	NLF	natural laminar flow
$C_D$	drag coefficient	PACS	pitch active controls system
$\Delta C_D$	change in drag coefficient	$R$	Reynolds number
c.g.	center of gravity	PAS	pitch-augmented stability
$C_L$	lift coefficient	PCU	power control units
$C_{L_{max}}$	lift coefficient at maximum lift	$S$	reference wing area
$c_l$	section lift coefficient	SIFT	Software Implemented Fault Tolerance
$C_P$	pressure coefficient	SST	supersonic transport
$D$	drag	$t/c$	thickness-to-chord ratio
EET	Energy Efficient Transport	$V$	velocity
FTMP	Fault-Tolerant Multiprocessor	WBPPW	wing-body-pod-pylon-winglet analysis code
GLA	gust load alleviation	WLA	wing load alleviation
HLFC	hybrid laminar flow control	$x/c$	fraction of wing chord
IAAC	Integrated Application of Active Controls	$y/(b/2)$	fraction of semispan
IEM	integrated energy management	$\Lambda_{c/4}$	sweep angle at quarter-chord
$L$	lift	$\alpha$	angle of attack
$L/D$	lift-to-drag ratio	$\sigma$	standard deviation
		$\rho$	mass density of air

## SUMMARY

The Energy Efficient Transport (EET) Program began in 1976 as an element of the NASA Aircraft Energy Efficiency (ACEE) Program. This report describes the EET Program and summarizes the results of various applications of advanced aerodynamics and active controls technology (ACT) to future subsonic transport aircraft. Advanced aerodynamics research areas included high-aspect-ratio supercritical wings, winglets, advanced high-lift systems, natural laminar flow, hybrid laminar flow control, nacelle aerodynamic and inertial loads, propulsion/airframe integration (e.g., long-duct nacelles), and wing and empennage surface coatings. In-depth analytical/trade studies, numerous wind tunnel tests, and several flight tests were conducted. Improved computational methodology was also developed.

The active control functions considered were maneuver load control, gust load alleviation, flutter mode control, angle-of-attack limiting, and pitch-augmented stability. Current and advanced active control laws were synthesized and alternative control-system architectures were developed and analyzed. Integrated application and fly-by-wire implementation of the active control functions were design requirements in one major subprogram.

Percent-fuel-reduction was the figure of merit or primary result in most of the studies. Fuel savings were realized from reduced drag, increased maximum lift coefficient, improved propulsion management, and lighter weight structure. Typical improvements in fuel efficiency were 3 to 6 percent for winglets (applied to the McDonnell Douglas DC-10, Boeing 747, and U.S. Air Force KC-135), 5 to 10 percent for wing planform and center-of-gravity changes as a result of applying ACT, and 15 to 20 percent when advanced aerodynamics and ACT were fully integrated into a new wing and empennage design. When other maturing technologies, such as advanced propulsion and composite structures, were included, fuel savings as high as 40 percent were predicted.

## INTRODUCTION

The dramatic increase in fuel prices since 1973 caused air transport design emphasis to shift from using advanced technology for increased cruise speed (ref. 1) to using advanced technology for increased fuel efficiency (ref. 2), as shown in figure 1. The increase in fuel prices and the specter of fuel shortages prompted initiation of the NASA Aircraft Energy Efficiency (ACEE) Program (ref. 3) in 1976. One element of this program, the Energy Efficient Transport (EET), was a focused research effort in advanced

aerodynamics and active controls with the specific objective of increasing air transport fuel efficiency by 15 to 20 percent. Typical advanced technologies considered in the EET Program are shown in figure 2.

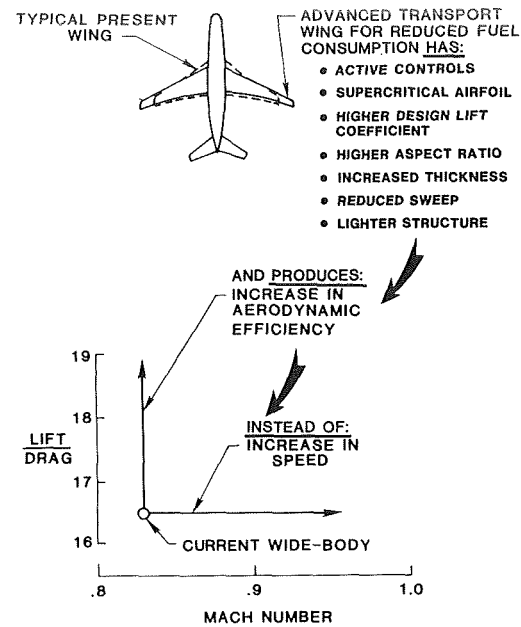

Figure 1. 1980's emphasis on advanced transport design.

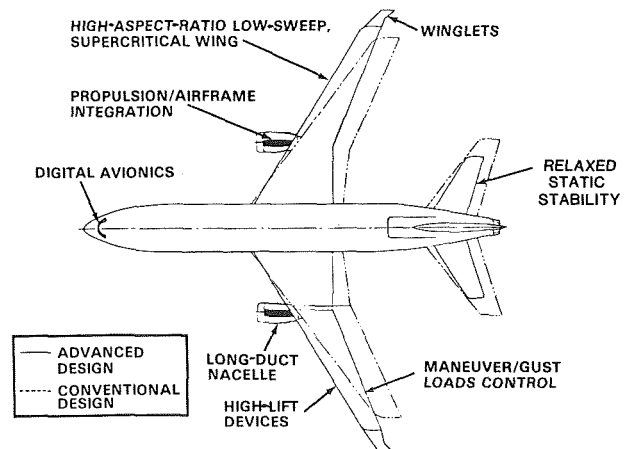

Figure 2. Typical advanced EET technology.

The EET Program sponsored in-house research activities and cost-shared contracts with the Boeing Commercial Airplane Co., Douglas Aircraft Co., and Lockheed-California Co. for analysis, preliminary design, testing, and in-depth assessment of selected advanced concepts. The parallel and cooperative involvement of both government and industry researchers and facilities led to a strong and close relationship, which resulted in rapid transfer of technology to both derivative and new aircraft designs.

This report briefly reviews the EET Program and some of the benefits that can be obtained from application of the advanced technologies to subsonic transport aircraft. System details and methods of technology application are covered in the documents listed in the bibliography (see the appendix). (A general discussion of the EET Program is also included in ref. 4.)

## DESCRIPTION OF RESEARCH AND RESULTS

EET advanced aerodynamic and active controls research was designed to advance technologies related to aircraft fuel efficiency. Some work was generic, whereas other efforts were directed toward transforming concepts into hardware and software that could be tested on specific airplanes. EET research—described in the following sections—included analyses, wind tunnel tests, configuration studies, control law synthesis, system development and implementation, and flight testing. Percent-fuel-reduction is used herein as the common indicator of improved energy efficiency, although such results are not strictly comparable from study to study because the baselines for such work often differed.

## Advanced Aerodynamics

Most of the advanced aerodynamics research performed under the EET Program was directed toward developing high-aspect-ratio supercritical-wing technology. Considerable effort was also directed toward advanced high-lift systems, winglets, nacelle aerodynamic and inertial loads, propulsion/airframe integration (including long-duct nacelles), aircraft surface coatings, laminar flow studies, and improved computational methodology.

### High-Aspect-Ratio Supercritical-Wing Technology

The groundwork for supercritical wing technology began at Langley Research Center in the early 1960's with research on supercritical airfoils by Whitcomb (ref. 5). By the time the EET Program was initiated, the thick, highly cambered supercritical airfoils required for high-aspect-ratio wings had been developed (ref. 6). The next step, of course, was to incorporate these airfoils into a practical wing design that would be both aerodynamically and structurally efficient.

Representative high-aspect-ratio supercritical-wing research conducted under the EET Program at Langley is depicted in figure 3. The wings that were tested provided a data base on the effects of thickness, camber, sweep, and aspect ratio (ref. 7).

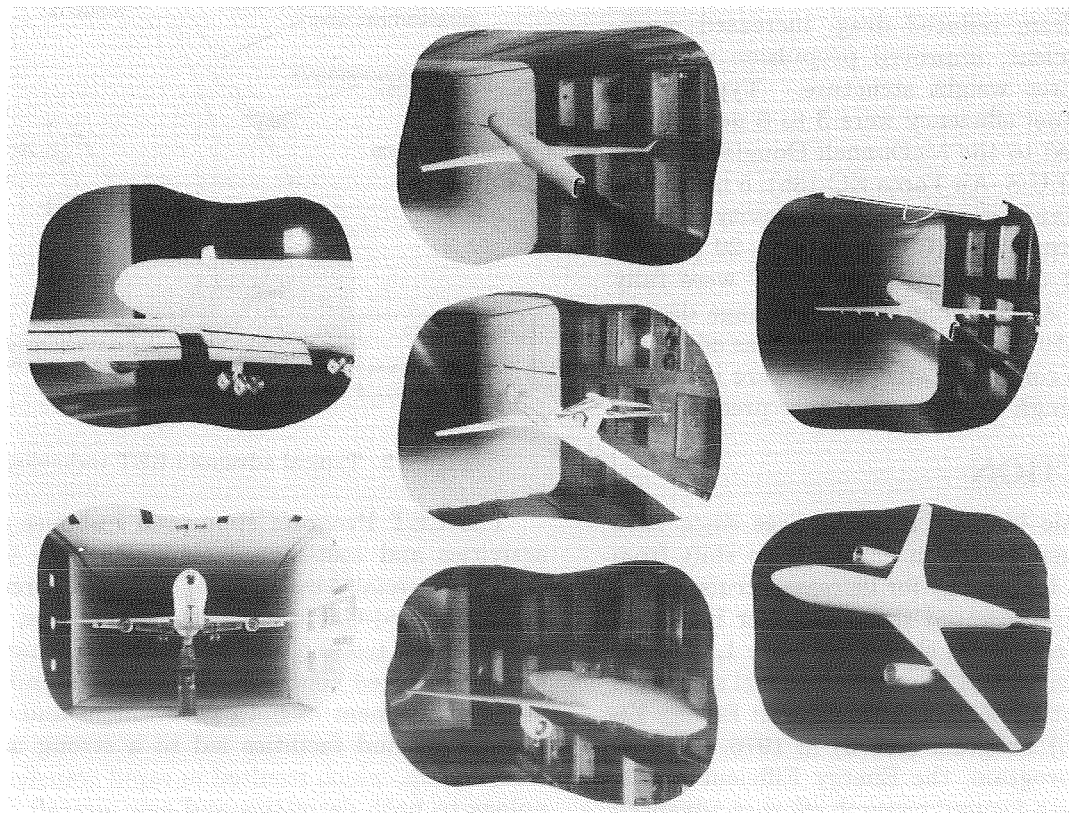
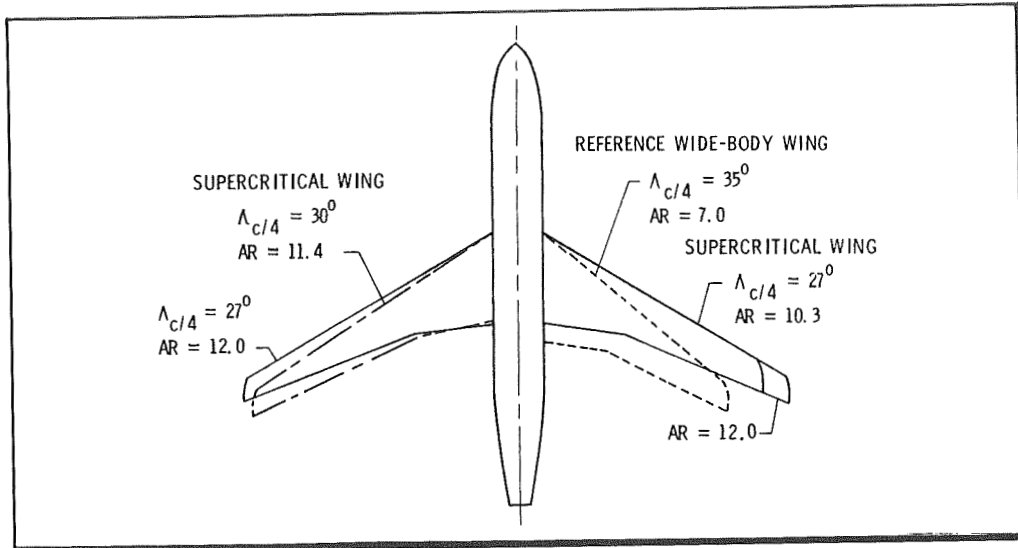

Figure 3. Langley high-aspect-ratio supercritical-wing experimental research.



## PLANFORM VARIABLES



## SECTION VARIABLES

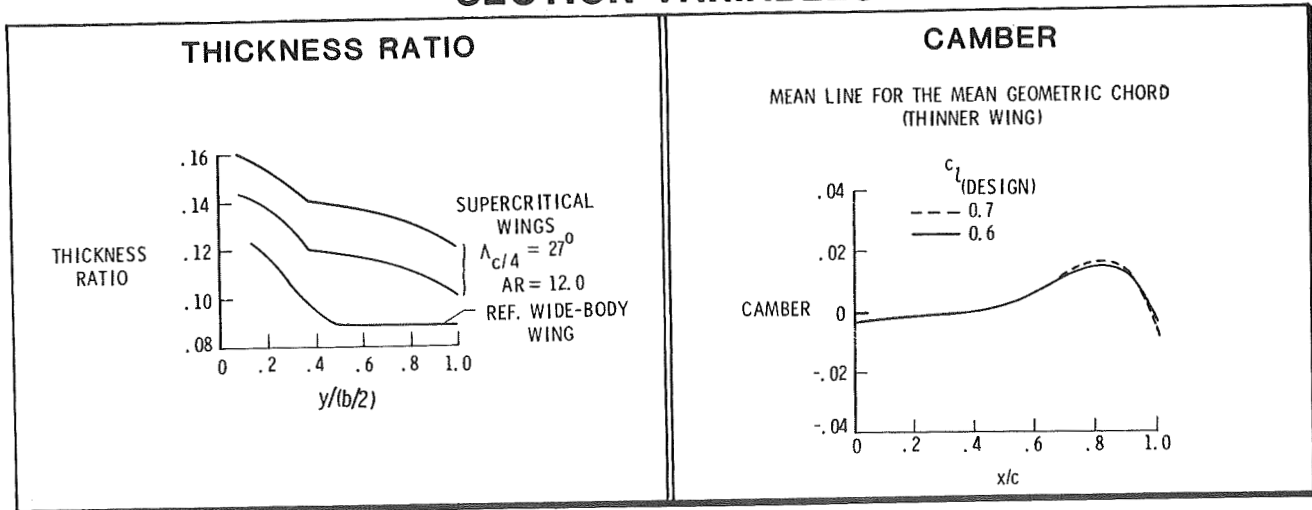

Figure 4. Supercritical-wing planform and section variables.

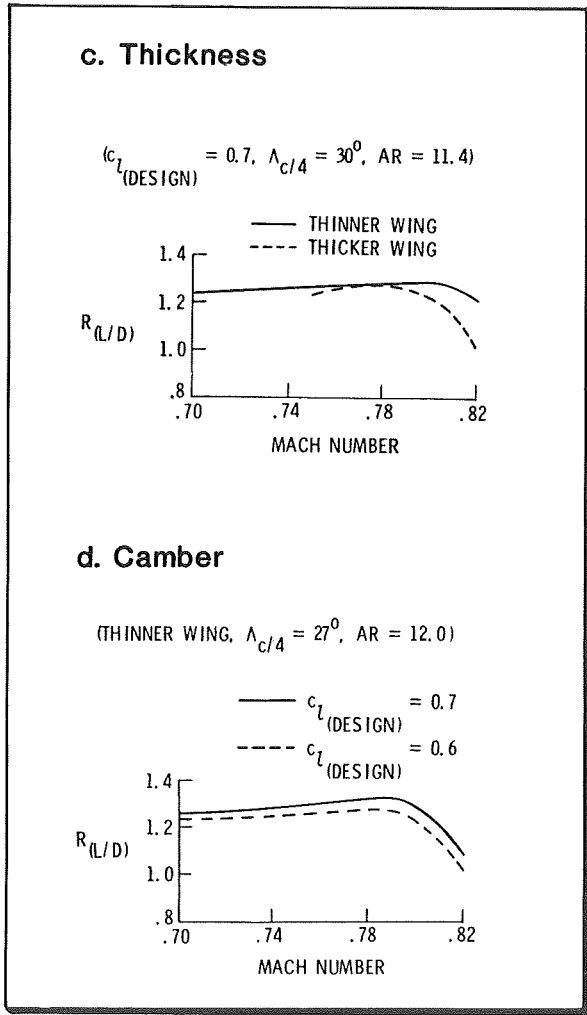
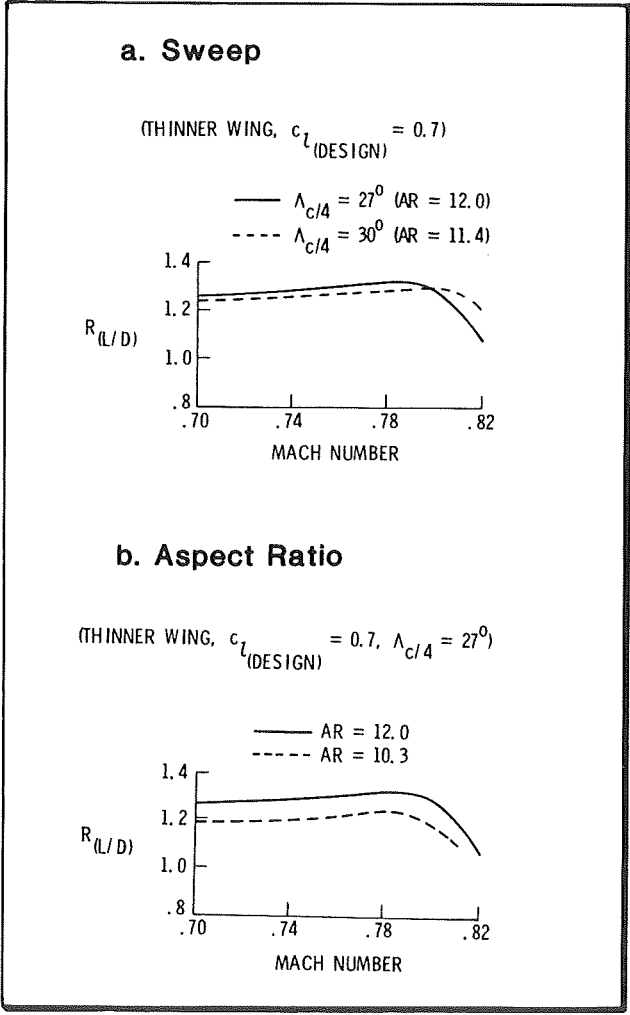

Figure 5. Effect of planform and section variables on lift-to-drag ratio relative to that of reference wide-body wing.

Planform and section variables are shown in figure 4, and results are presented in figure 5 as relative lift-to-drag ratios ( $R_{(L/D)}$ ). This ratio is defined as the supercritical-wing  $L/D$  at a lift coefficient of 0.60 divided by the conventional current wide-body  $L/D$  at a lift coefficient of 0.45. These lift coefficients are near the maximum  $L/D$  for each configuration. In addition, for specific supercritical-wing configurations, extensive wind tunnel testing was performed (refs. 8, 9, and 10) to study high-lift systems, propulsion/airframe integration, lateral controls, trim drag, and various tail arrangements. Also under EET sponsorship, the Advanced Technology Airfoil Program (ref. 11) was initiated to test both advanced and conventional airfoils in the Langley 0.3-Meter Transonic Cryogenic Tunnel. This NASA/industry cooperative effort has provided valuable airfoil data at large-transport flight-equivalent Reynolds numbers (e.g., 45 million).

Parallel with the NASA in-house effort, Douglas was contracted to conduct research and development studies of applying supercritical-wing technology to advanced transport designs—primarily medium-range wide-body and narrow-body transport configurations (refs. 12 and 13). The resulting improvement in wing design technology is illustrated in figure 6 by the significant reduction of *drag creep* between the initial wide-body design and the follow-on narrow-body design. (*Drag creep* is the premature increase in drag that occurs before the final drag rise.) The initial wing development program was followed by further wind tunnel testing to define the complete aircraft configurations, with much of this effort being devoted to high-lift technology (ref. 14). Both the narrow-body and the wide-body configuration had tail-off maximum lift coefficients ( $C_{L_{max}}$ ) in excess of 3.1, obtained at wind tunnel Reynolds numbers, compared with 2.5 for current transports. In fact, as shown in figure 7,  $C_{L_{max}}$  was still increasing at the highest wind tunnel Reynolds number tested (approximately 6 million). The Douglas effort not only generated a large supercritical-wing data base but also established design procedures necessary to apply the technology confidently to new transport designs.

### Winglets

Winglets were investigated (refs. 15–19) primarily as a technology feature to be either retrofitted to existing aircraft or included on derivatives of existing aircraft. The EET Program cosponsored flight test evaluations of winglets on two airplanes: a KC-135 (fig. 8) and a DC-10 (fig. 9). Winglets for the 747 (fig. 10) were also investigated, but not flight tested.

The KC-135 and the 747 had upper winglets only, while the DC-10 had a small lower winglet attached

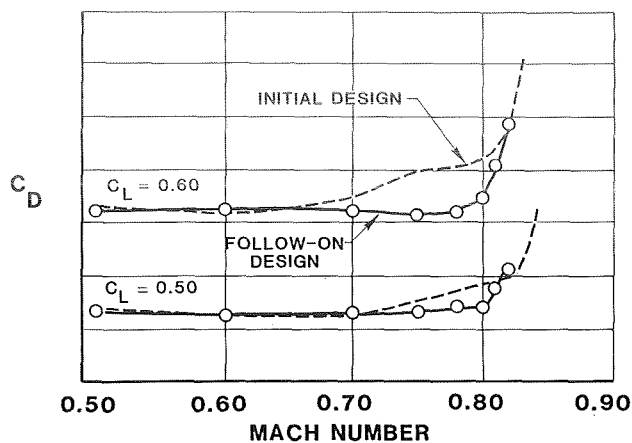

Figure 6. Drag-rise characteristics of Douglas advanced transport configurations.

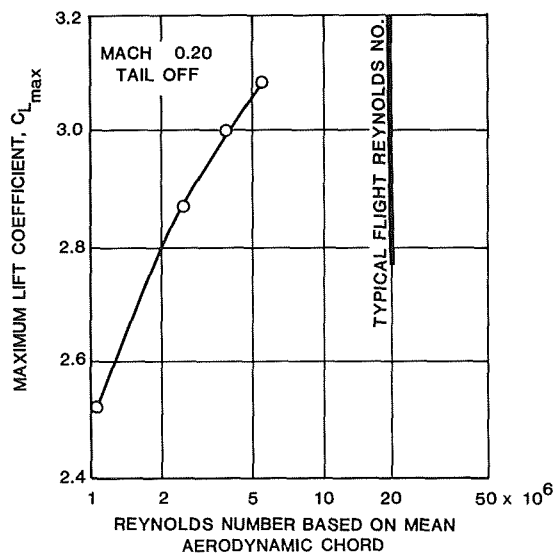

Figure 7. Effect of Reynolds number on  $C_{L_{max}}$  of Douglas advanced transport configurations.

forward of the upper winglet. Also, the span of the DC-10 upper winglet was truncated (to two-thirds of its original length) part way through the flight test program to assess the trade-off between loads and performance. The modified configuration (see insert in fig. 9) was tested both with and without the lower winglet. The 747 winglet configuration spanned the entire wing-tip chord, whereas the upper winglets on the KC-135 and DC-10 extended over approximately the aft 60 percent of the tip chord.

The KC-135 is a first generation jet transport, designed to have a nearly elliptical span load distribution at cruise. The DC-10 and 747, however, are second generation jet transports with span load distributions that are off-loaded near the wing tip. This off-loading, which was done as a compromise between

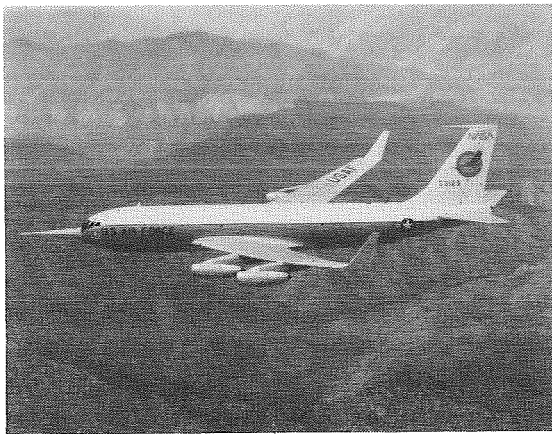

Figure 8. KC-135 winglet flight evaluation.

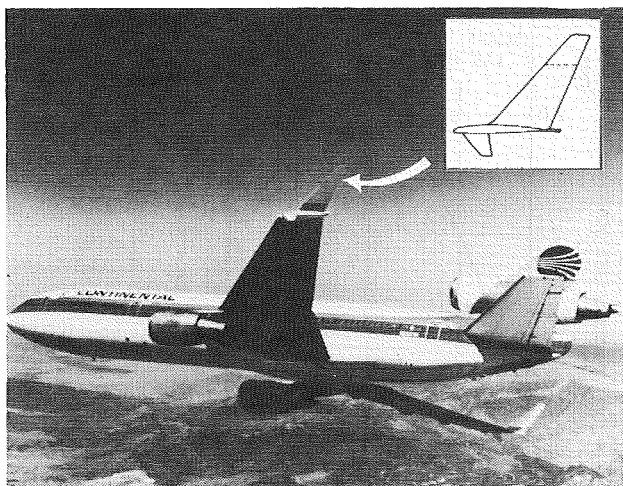

Figure 9. DC-10 winglet flight evaluation.

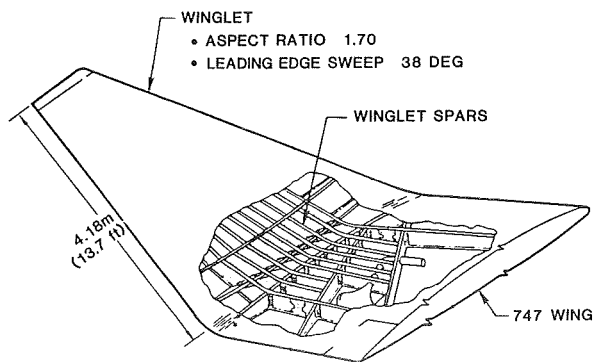

Figure 10. Proposed winglet for 747-200.

structural weight and aerodynamic efficiency, is typical of second generation wide-body transport designs. Consequently, the gains to be expected from the application of winglets to second generation jet

transports are considerably less than for first generation aircraft such as the KC-135 (ref. 16).

The KC-135 Winglet Flight Test Program (ref. 17) was a joint NASA/Air Force effort. Flight test results indicated that the winglets reduced drag by approximately 5.5 percent compared with 7 percent predicted by wind tunnel results. DC-10 winglet flight test results (ref. 18) indicated a 2-percent drag reduction at cruise compared with the 3-percent reduction predicted from wind tunnel results. An additional 1-percent reduction was obtained in flight by drooping the outboard aileron to increase the loading near the wing tip. It is not clear why the wind tunnel results predicted larger drag reductions in both cases, although the lower wind tunnel Reynolds numbers may have been a significant contributing factor. Winglet technology developed in the DC-10 winglet program, however, has provided Douglas with the confidence to consider winglets in the design of new aircraft such as the C-17.

Similarly, Boeing is considering winglets for future generations of commercial aircraft, even though the results of their EET-sponsored study (ref. 19) of retrofitting winglets on a 747-200 indicated that wing modification costs would be too high relative to expected fuel savings (2 to 3 percent).

#### Nacelle Aerodynamic and Inertial Loads (NAIL)

A large part of the deterioration in engine efficiency occurs very early in the life of a jet engine; thereafter the loss is more gradual (fig. 11). The Nacelle Aerodynamic and Inertial Loads (NAIL) Program (ref. 20) was initiated to provide "early life" flight test data on the effect of propulsion system aerodynamic and inertial loads (viz, flight loads) during typical flight operations. Also, engine blade-tip clearances were measured in real time (with a laser system) so that they could be related to the instantaneous flight loads. At the conclusion of the tests, Pratt & Whitney Aircraft disassembled the NAIL engine and made appropriate measurements to determine the wear on the blade tips and inner wall of the engine case. Pratt & Whitney had carefully rebuilt and documented this engine just before the flight tests.

The NAIL flight test results indicated (ref. 21) that the highest flight loads occur at low speed, high angle of attack, and high engine airflow. The NAIL data were also converted to generalized nondimensional form (ref. 22) to permit estimation of flight loads on other wing-engine installations; thus, the project provided a data base for designing nacelles and pylons that can resist deformation due to flight loads.

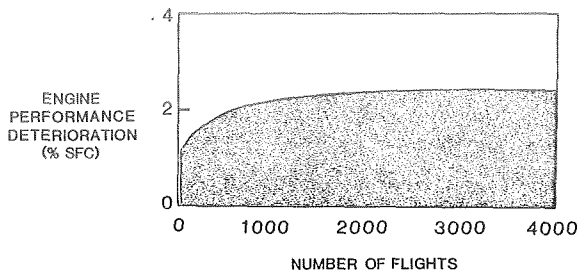

Figure 11. Engine performance deterioration, due to nacelle aerodynamic and inertial loads.

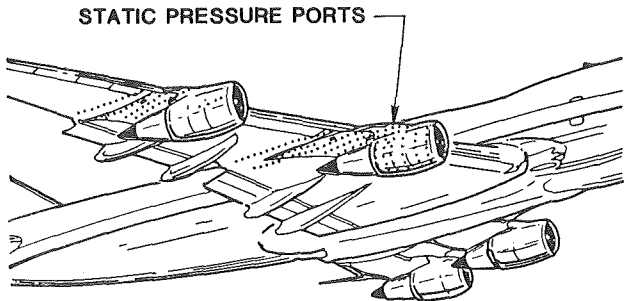

Figure 12. Typical locations of pressure orifices on 747 for flow field measurements.

A second objective of the NAIL program was to measure surface static pressures near the inboard and outboard engine installations in sufficient detail

to permit an accurate definition of the flow field. Accordingly, over 600 static pressure sensors were embedded in the locations indicated in figure 12. This type of flight data is very important for research aimed at reducing engine/airframe interference drag.

### Aircraft Surface Coatings

An Aircraft Surface Coatings Program (ref. 23) was conducted to identify materials that would reduce maintenance by offering protection from leading-edge erosion while also reducing surface roughness. The program included extensive laboratory testing of candidate materials, flight service evaluation on Boeing 727 aircraft in actual airline operation, and a flight test program to measure drag differences for two surface coating materials (fig. 13). Avco Systems Division assisted Boeing throughout the program and conducted most of the laboratory tests. The results of the program indicate that elastomeric polyurethane coatings, when properly applied, do effectively protect the leading edge from erosion and can also produce a small drag reduction. Limited testing for corrosion protection indicated that these coatings provided protection at least equivalent to that provided by products currently being used. The future use of these coatings will depend on how well they stand up when applied to large surfaces having

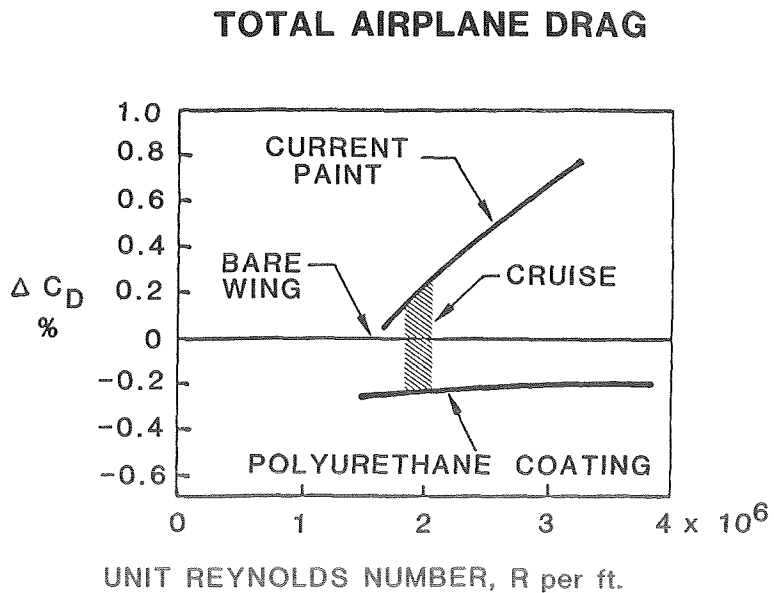
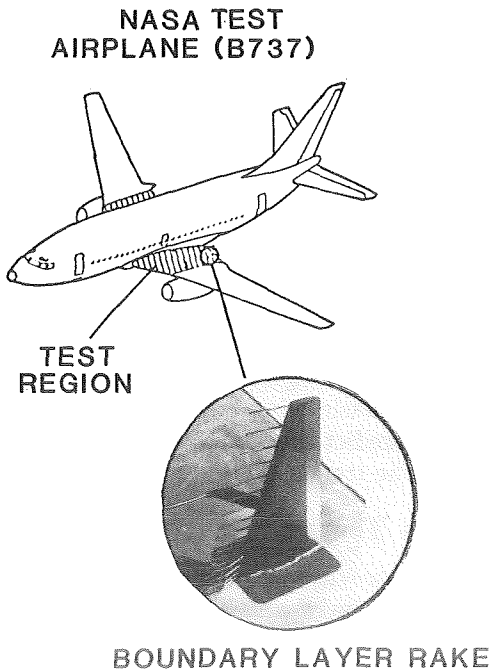

Figure 13. Effect of surface coatings on airplane drag.

compound curvature and on the economics of application and maintenance. The results of the program, however, are very promising.

### Laminar Flow Research

The EET Program sponsored two laminar flow studies at Boeing: the first investigated the application of natural laminar flow (NLF) to a 200-passenger transport (ref. 24) and a follow-on study investigated the application of hybrid laminar flow control (HLFC) to a Boeing 757 (ref. 25). HLFC involves surface suction in the region of the wing ahead of the front spar combined with pressure-distribution tailoring over the wing box to maintain laminar flow over a large portion of the wing chord (fig. 14). Analysis showed that application of HLFC to a 757-200 yielded a fuel saving of 8.2 percent for a  $M = 0.80$ , 3900-km mission.

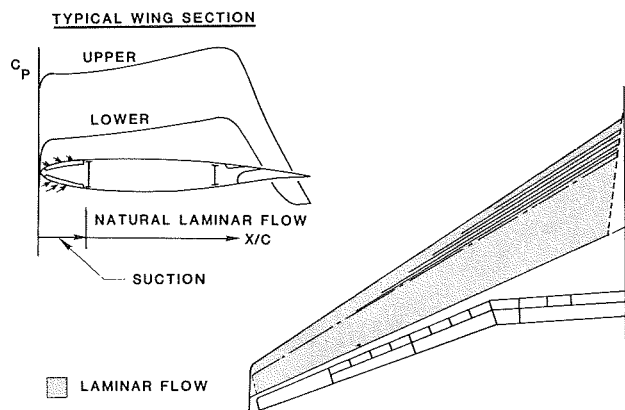

Figure 14. Hybrid laminar flow control (HLFC) concept.

The EET Program also sponsored a NASA flight test program in which a supercritical NLF airfoil was gloved onto the wing of the F-111 TACT aircraft (fig. 15) at the Dryden Flight Research Facility. Laminar flow was obtained to about 50 percent of the chord at sweep angles up to  $15^\circ$  and chord Reynolds numbers of 28 million (ref. 26). (Significant amounts of laminar flow were also obtained at sweep angles as high as  $20^\circ$ .) This flight test provided the first definitive flight results on the effects of wing sweep angle on boundary-layer transition and indicates that the adverse effect of sweep may not be as large as previously thought (ref. 24).

More detailed laminar flow studies leading to flight tests on an F-14 are now ongoing under the Laminar Flow Control Element (ref. 27) of the ACEE Program.

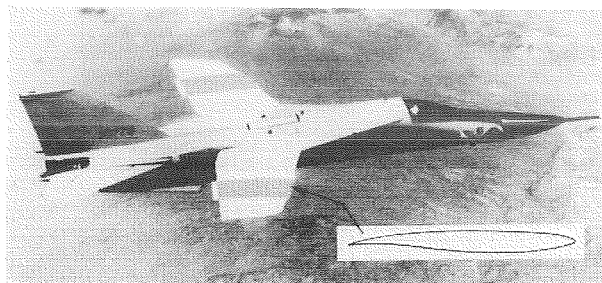

Figure 15. F-111 TACT aircraft with natural laminar flow gloves.

### Computational Aerodynamics

The EET Program also sponsored research to develop improved aerodynamic computational capability for transport configurations in the transonic speed range. At the time the EET Program was initiated, three-dimensional full-potential codes were still in their early stages of development, and the probability that these codes would ever be able to handle complete transport configurations seemed remote. The EET Program, therefore, sponsored the development of a three-dimensional small disturbance transonic analysis code using a grid-embedding technique that offered the potential of handling complete configurations. This code (the latest version is referred to as WBPPW, wing-body-pod-pylon-winglet), developed primarily by Boppe (refs. 28 and 29) at Grumman Aerospace Corp., can calculate the flow field of a wing-body having two pylon and pod arrangements and both an upper and a lower surface winglet. Other versions of the code can also handle configurations with horizontal tails and canards (refs. 30-32). Although the capability of the three-dimensional full-potential codes has improved tremendously over the past few years, the WBPPW code still provides the designer with a unique tool for calculating flow fields of complex geometries. In figure 16, WBPPW calculations are compared with wind tunnel results for an advanced transport configuration to show the effect of adding an advanced long-duct nacelle and pylon arrangement to the basic wing-body (ref. 33). The theoretical results predict the experimental data very well, particularly the trends.

### Active Controls Technology (ACT)

Active controls provide aerodynamic and structural benefits, particularly when ACT is considered throughout the aircraft design cycle rather than applied to a configuration after it has been shaped and engineered by customary methods. In the EET-sponsored research, Douglas, Lockheed, and Boeing applied ACT to several airplane configurations reflecting their existing or proposed future product

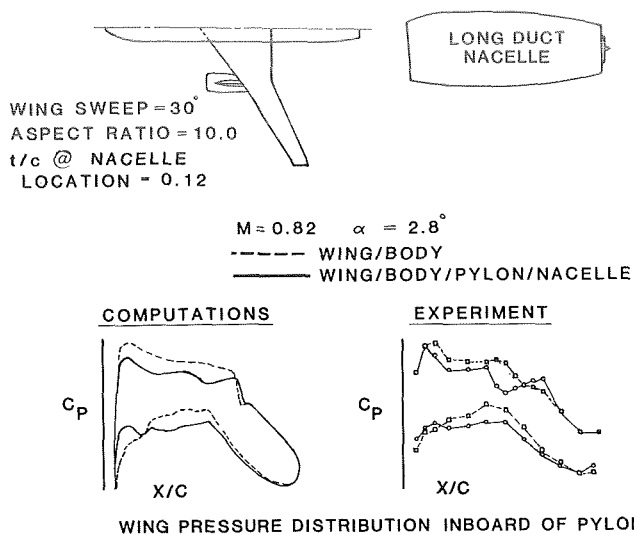

Figure 16. Comparison of computed (WBPPW code) and experimental wing pressure distributions for an advanced transport configuration.

lines. The EET Program also supported in-house research efforts related to integrated analysis and design techniques, fault-tolerant implementation technology, and aircraft handling qualities.

### Control of Aeroelastic Responses

ACT provides a means of controlling aircraft structural vibration modes through deflection of trailing-edge surfaces on the wing and/or empennage in response to commands from computer-sensor control loops. Wing flutter is suppressed by artificially increasing the damping of selected high-frequency structural modes, so that the flutter placard speed is increased beyond the airplane's expected maximum operating speed without adding any additional structural weight. Maneuver load control (MLC) involves reducing wing bending moments during maneuvering flight. Similarly, gust load alleviation (GLA) results in reduced structural loads when an airplane penetrates vertical gusts. MLC and GLA collectively comprise the active control function called "wing load alleviation" (WLA).

Douglas (ref. 34) investigated the impact of ACT systems on the flutter and gust load characteristics of a DC-10 derivative that had approximately 4.3 meters added to its wing span. Semispan and full-span aeroelastic models (0.045 scale) equipped with high-speed outboard ailerons and a single vertical accelerometer in each wing tip were tested in the Douglas, Long Beach, low-speed tunnel and in the Northrop low-speed tunnel, respectively. Control laws derived by classical methods increased flutter speed by up to 19 percent and significantly de-

creased the first wing-bending mode accelerations. NASA supplied alternative control laws, one based on optimal control theory and the other based on the Aerodynamic Energy Method (ref. 35); both NASA control laws increased flutter speeds by more than 25 percent (ref. 36). Representative damping vs. speed results for the three types of control laws are shown in figure 17.

Initial EET studies at Lockheed-California (ref. 37) involved extending the wing span of an L-1011 by 2.75 meters and providing a WLA system involving symmetrical operation of the outboard ailerons (which on the L-1011 are still operative at high speed). As illustrated in the top part of figure 18, the WLA system redistributes the wing lift and thus eliminates the need for significant structural redesign and/or increase in structural weight to support the extended wing span. During pushover and pull-up type maneuvers, the WLA system reduced vertical wing-bending moments but increased torsional loads, as shown in the bottom part of figure 18. The estimated total increase in semispan weight for a production L-1011 airplane modified in this manner would be about 150 kg—125 kg for the wing-tip and aileron extension and 25 kg for added structural material to strengthen the wing inboard of the extension. This configuration was implemented and flight tested on Lockheed's L-1011 research airplane and the predicted 3-percent fuel saving was verified (ref. 37). Lockheed introduced the system in 1980 on the L-1011-500, and commercial performance has been good.

### Pitch Stability Augmentation

To take advantage of the improvements in aerodynamic cruise efficiency available from advanced technology wings, static margin must be reduced. This can be achieved by moving the c.g. 15 to 20 percent mac aft or by reducing horizontal tail size. In either case, some type of stability augmentation must be provided to maintain flight safety and keep aircraft handling qualities at acceptable levels.

Boeing developed an active pitch-augmented stability (PAS) system for an advanced 757 or 767 type transport. It involves multiple feedback loops and dedicated sensors and actuators and is appropriate for fly-by-wire application. Control laws were synthesized using both classical and optimal control theory methods. To ascertain the effectiveness of the PAS system during flight maneuvers under negative stability conditions, selected PAS control laws were incorporated into the high-fidelity math model associated with the 757 motion simulator at Boeing. Pilots evaluated the system (ref. 38) while performing typical 757 maneuvers with the c.g. of the air-

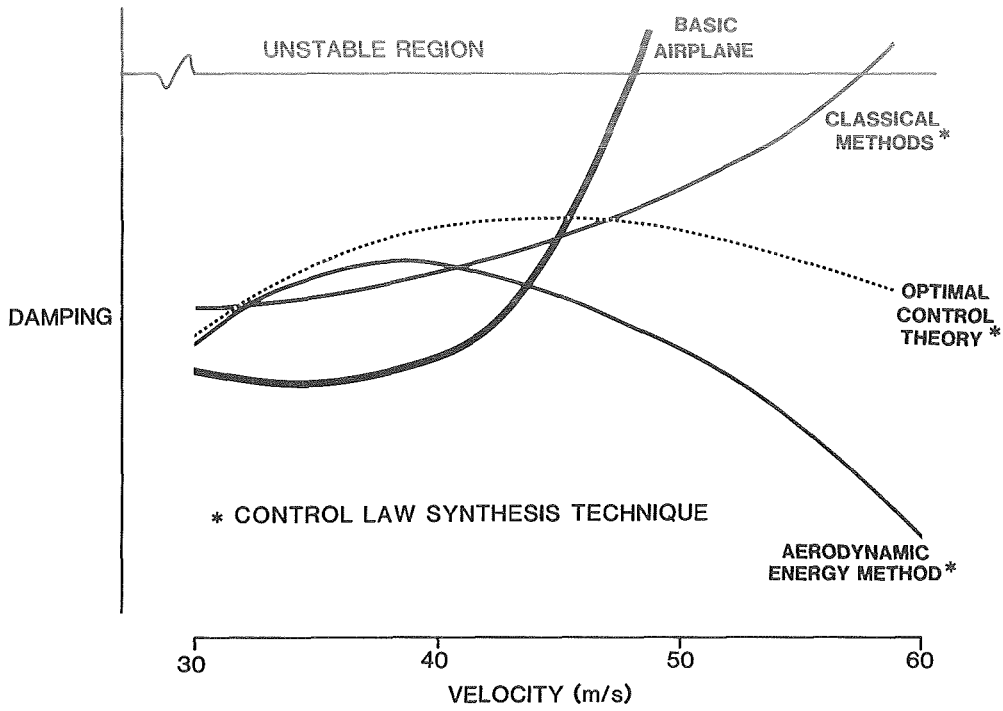

Figure 17. Velocity vs. damping curves for derivative DC-10 using alternative control laws.

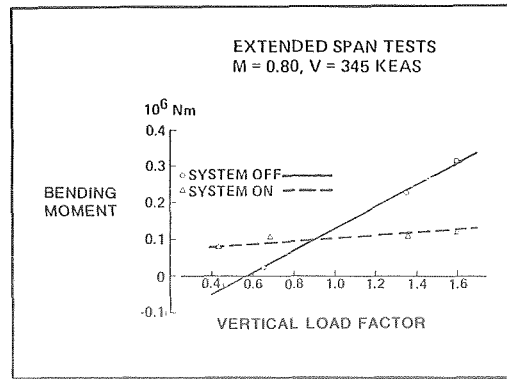
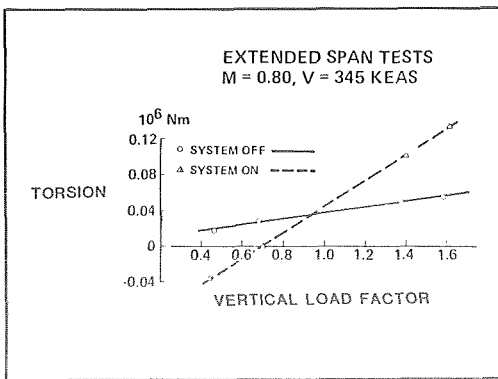
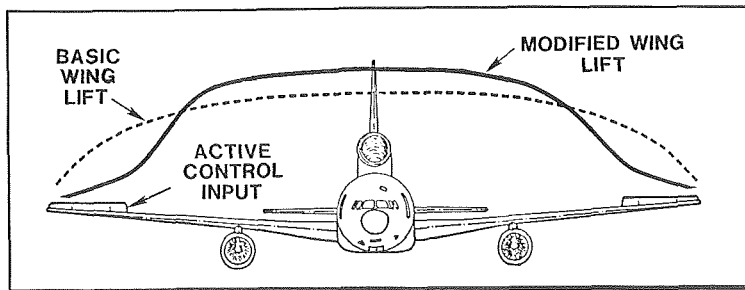

Figure 18. Wing load alleviation effects on L-1011, determined at 71 percent semispan.  $M = 0.80$ ; estimated airspeed, 345 knots.



craft located up to 20-percent-mac behind the neutral point. Trends are shown by the dashed line pairs (envelope of pilot rating data) in figure 19. As expected, the unaugmented airplane soon became un-flyable as the c.g. was moved aft of the neutral point. However, with the pitch augmentation system, the airplane handled well throughout the test c.g. range.

Lockheed developed and tested (refs. 39-41) a near-term pitch active controls system (PACS) containing a "lagged pitch damper" and a "feedforward command loop with washout." Simulation test results indicated that such a system would be quite effective over an extended c.g. range from 0.15 to 0.43 mac (the neutral point was at about 0.40 mac). The system was developed and installed on an L-1011 company airplane and evaluated in flight by two Lockheed and two NASA test pilots. The pilots reported that the handling qualities over the test c.g. range (corresponding to -3 to +15 percent static margin) were as good as or better than those experienced earlier in the simulator.

An advanced PACS (ref. 42) was also developed by Lockheed and evaluated on the Langley Visual/Motion Simulator. The advanced PACS contained feedforward and multiple feedback loops and secondary gain scheduling to compensate for instabilities during maneuvering at high Mach numbers. Handling qualities (shaded bands in fig. 19) were quite similar to those for the 757.

Further EET studies (ref. 43) at Lockheed showed that the horizontal tail area of an L-1011 could be reduced by about 30 percent if a PACS-type active control system was added to compensate for the attendant loss of inherent stability. Such a tail configuration would reduce total airplane drag by at least 2.5 percent and provide a fuel saving of up to 3 percent (fig. 20) when operating near the design cruise c.g. (0.25 mac). The right side of figure 20 indicates that a similar fuel saving is available if the tail size is not reduced and the c.g. is moved well aft of the neutral point. The lower curve shows that moving the c.g. aft with the current L-1011 wing would yield a fuel saving of up to 2 percent; the upper curve indicates that moving the c.g. aft with an advanced technology L-1011 wing (combining ACT with supercritical-wing aerodynamics) could potentially provide a fuel saving of 16 percent (12 percent attributed to the high-aspect-ratio supercritical wing and up to 4 percent for aft c.g. location).

Douglas also investigated (ref. 44) the use of pitch stability augmentation on their proposed DC-X-200, a twin-engine derivative of the DC-10. The design philosophy was to establish a baseline airplane (unaugmented) that had no worse than "minimum acceptable" handling qualities during maneu-

vering anywhere in the flight envelope. Pitch stability augmentation would then be added to maintain or improve the handling qualities to "satisfactory." (Fig. 19 relates satisfactory handling qualities to a Cooper-Harper pilot rating of 3.5 or less and "minimum acceptable" qualities to a rating of 6.5.)

Five pilots evaluated the baseline airplane on the Douglas motion-base simulator for a number of environmental, flight, and configuration conditions (over a c.g. range). Mean pilot ratings were computed for each condition, and the worst mean for each c.g. location was used to help define a conservative stability boundary curve—shown in figure 21 for landing approach. This curve crosses into the "unacceptable" handling qualities region (Pilot rating > 6.5) when the c.g. moves more than 3.1 percent mac behind the aerodynamic center. A similar curve for cruise crosses at -4.5 percent mac. Consequently, zero aerodynamic center margin was selected as the c.g. design point for the baseline DC-X-200. Figure 21 indicates that the expected pilot rating of the unaugmented baseline would be about 6.

The lower curve in figure 21 indicates that the expected fuel saving for the baseline airplane would be about 2.0 percent compared with a DC-X-200 configuration balanced to a more conventional stability margin of +10 percent mac. Fuel saving would increase to 2.5 percent for operations with the c.g. positioned at 3.1 percent mac behind the aerodynamic center (see dashed line).

Thirty-two candidate control laws were synthesized in the effort to provide satisfactory handling qualities for all flight conditions. Three control laws were selected for evaluation by six pilots during a second series of simulation tests, focusing on the baseline configuration (c.g. at the aerodynamic center). Even though the pilots indicated clear preferences for different control laws, the average rating overall for each control law was 3.8 (shown as a triple point in fig. 21). Details and schematics of all 32 control laws are given in appendix A of reference 44.

### Integrated Application of Active Controls (IAAC)

It is generally recognized that maximum benefits from the application of ACT will occur when all useful active control functions are applied at the beginning of an airplane design cycle. Such application would significantly reduce airframe weight, but would lead to the use of *critical systems* in which reliability is a major technical consideration. (The FAA defines *critical systems* to be systems essential to safe flight; the probability of loss of total system function must be *extremely remote*, or less than  $10^{-9}$  during a 1-hour flight.)

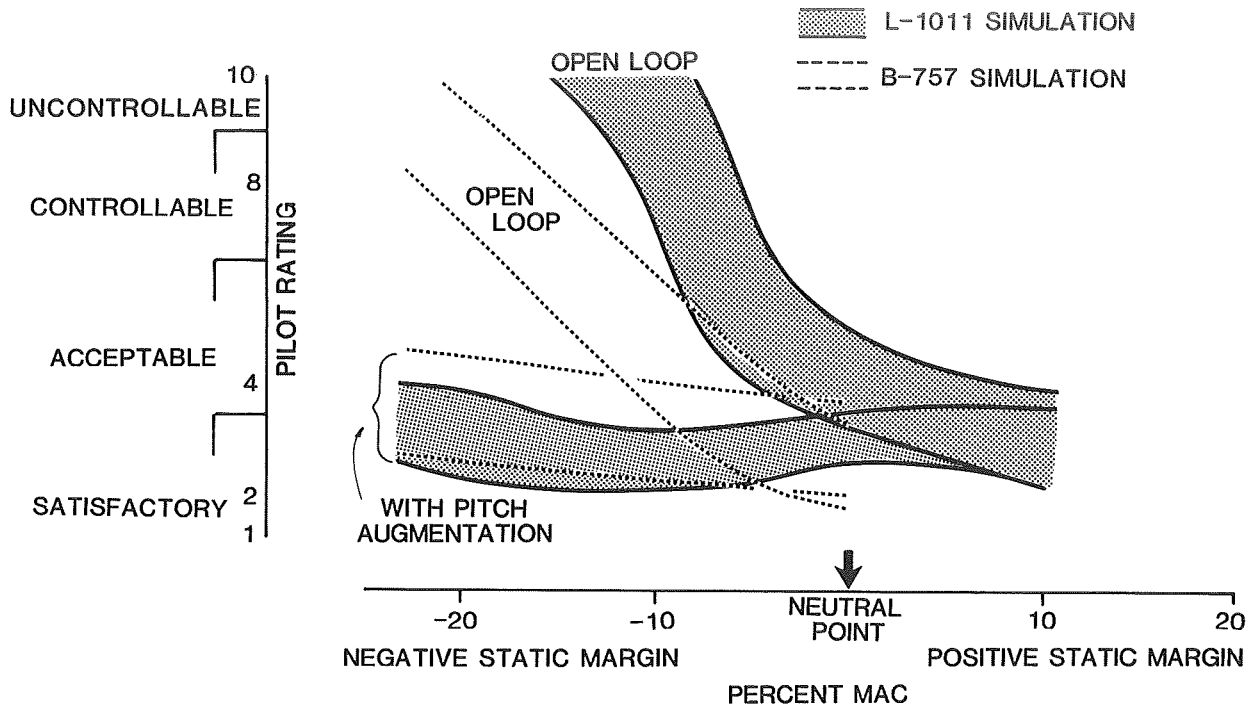

Figure 19. Simulator evaluation of two modern transports with and without pitch stability augmentation.

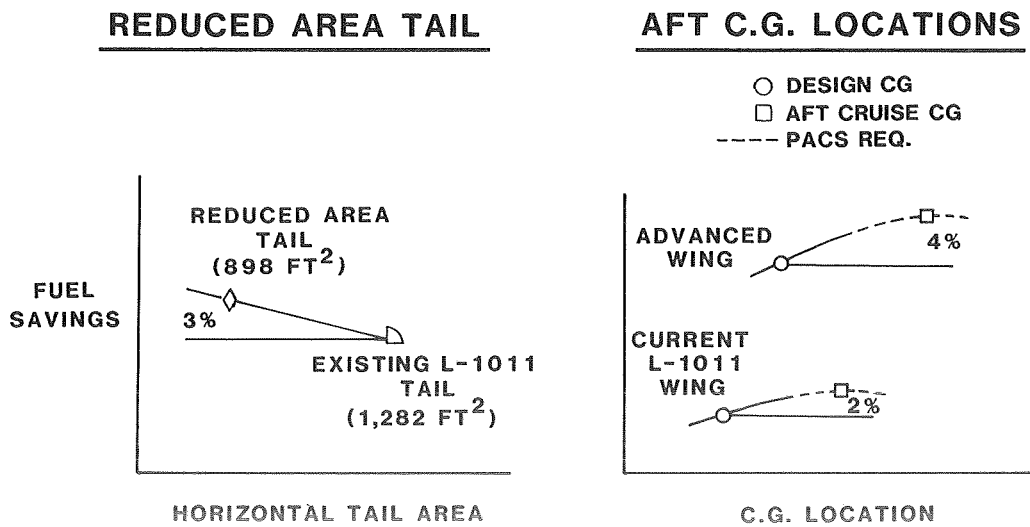

Figure 20. Effects of advanced wing, reduced-area tail, and aft c.g. on L-1011 fuel usage.

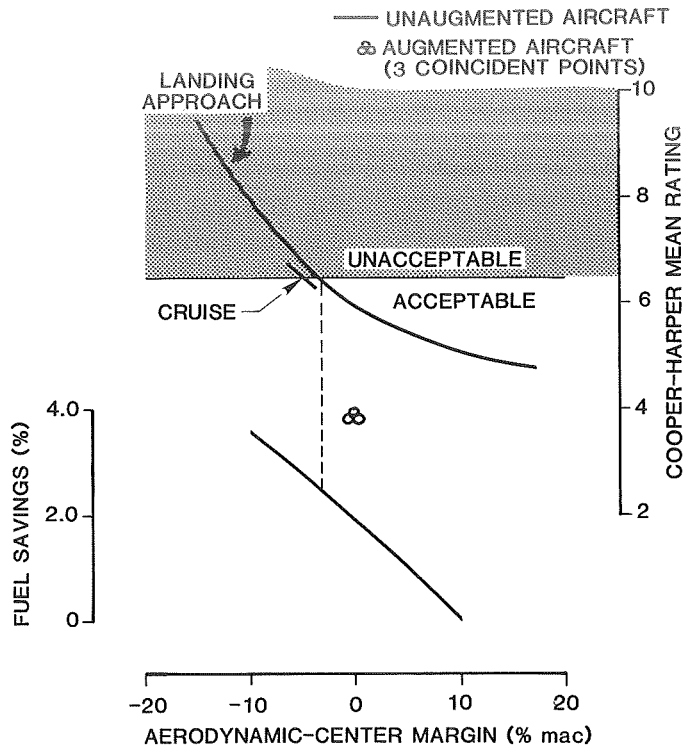

Figure 21. Effect of pitch stability augmentation on Douglas baseline DC-X-200 configuration.

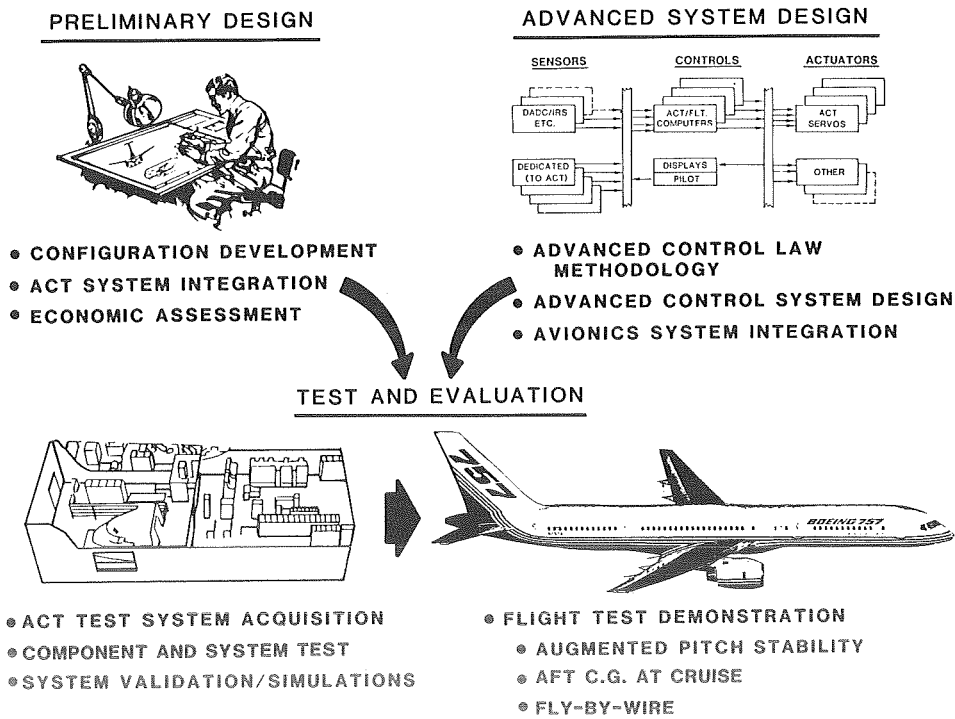

Figure 22. Illustration of program plan for Integrated Application of Active Controls (IAAC).

For their primary EET controls effort, Boeing elected to conduct an in-depth investigation of Integrated Applications of Active Controls (IAAC) technology to the design of an advanced (circa 1990) subsonic transport airplane. After conducting exploratory studies and identifying a reference airplane (ref. 45) having a large data base, Boeing developed a comprehensive plan (ref. 46) to simultaneously pursue configuration and control-system design activities (fig. 22). ACT was applied to the baseline airplane design (a high-tail version of the 767) to provide new configurations (refs. 47 and 48) that took advantage of the structural modifications made possible by including a critical active control system performing the following functions: pitch-augmented stability (PAS), wing load alleviation (WLA), and angle-of-attack limiting (AAL). (Boeing refers to the *critical* PAS function as *crucial* in refs. 46-52.) Flutter mode suppression was also investigated but was determined to be unnecessary for the Final ACT Configuration (ref. 49).

Figure 23 shows the planform changes that the IAAC Study produced: the horizontal tail area was reduced 45 percent; the wing was moved 1.7 meters forward on the fuselage; and the wing aspect ratio was increased from 8.7 to 12.0. (Neither composites nor advanced aerodynamics were considered.) Economic studies showed that the Final ACT Configuration, with a current technology implementation of the above listed ACT functions, could reduce fuel requirements by 5 to 10 percent, depending on range (bottom of fig. 23). In-depth reliability and cost-of-ownership calculations verified the commercial feasibility of the system.

Encouraged by the results of the configuration and economic studies, Boeing continued with the advanced control-system work. Alternative implementation of active control laws based on modern control theory and integration of all flight, guidance, and navigation functions were studied (refs. 50 and 51). An ACT system architecture was devised and a test set of flight worthy active controls computers and test equipment was fabricated (ref. 52). This test system is currently undergoing evaluation in the Boeing Digital Avionics Flight Control Laboratory prior to eventual fly-by-wire flight tests on the company 757 or 767 test airplane. The architecture of such a test system is shown in figure 24.

### Fault-Tolerant Systems

As already mentioned, control-system reliability was quickly identified as a major technical issue, particularly for systems designed for fly-by-wire operation. The IAAC approach to providing the level of reliability demanded for a critical system was

to provide dissimilar redundancy in the active controls computers and multiple dedicated pitch-rate sensors and secondary elevator servos (see fig. 24). Other approaches investigated under EET sponsorship included the Software Implemented Fault Tolerance (SIFT) and the Fault-Tolerant Multiprocessor (FTMP) computer concepts. The SIFT concept (ref. 53) was developed under contract by Stanford Research Institute and an engineering computer was built by the Bendix Corp. Similarly, the FTMP concept (refs. 54-56) was developed by Charles Stark Draper Laboratories and fabricated by Rockwell-Collins International, Inc. These two approaches to fault tolerance are being further investigated and verified in the new Langley Avionics Integration Research Laboratory (AIRLAB) using the SIFT and FTMP hardware and software (ref. 57).

### Interdisciplinary Technology Applications

To ascertain the costs and benefits of comprehensive application of advanced technologies to the design of a new wing for a 350-passenger trijet, Lockheed investigated the following technology areas: airfoil and planform parameters, pitch active controls, all electric systems, advanced propulsion, propulsion/airframe integration, graphite-epoxy composites, silicon carbide/aluminum composites, and advanced metal alloys. These technologies were applied to a baseline aircraft both individually and concurrently (ref. 58). Maximum fuel reduction (40 percent) resulted from application of a blend of wing and propulsion parameters, advanced systems, and composites. The combination of advanced aerodynamics and active controls produced nearly one-half of this improvement. The study also pointed out that certain technologies require the concurrent application of certain other technologies for any meaningful benefits to accrue (e.g., winglets and WLA).

The EET Program has also supported development of advanced design procedures that allow the full benefits of advanced aerodynamics and active controls to be combined with and reflected in structural designs. One such procedure was applied (ref. 59) to the design of an actively controlled aeroelastic research wing (ARW-2) for testing on a Navy Firebee II drone. A wind tunnel model of the test vehicle is shown in figure 25. The high-aspect-ratio ARW-2 has a supercritical airfoil and was purposely designed to require active flutter suppression, gust load alleviation, maneuver load control, and stability augmentation within the flight envelope. The full-scale wing model will be both wind tunnel and flight tested, in order to provide a direct data correlation and eliminate questions concerning tunnel-wall and Reynolds number effects.

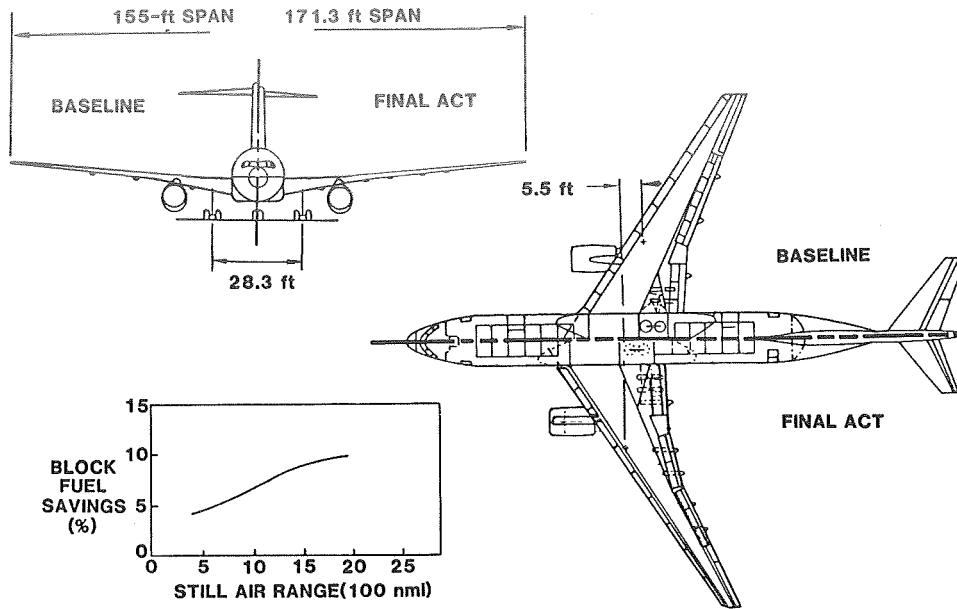

Figure 23. Comparison of Boeing baseline and final ACT configurations.

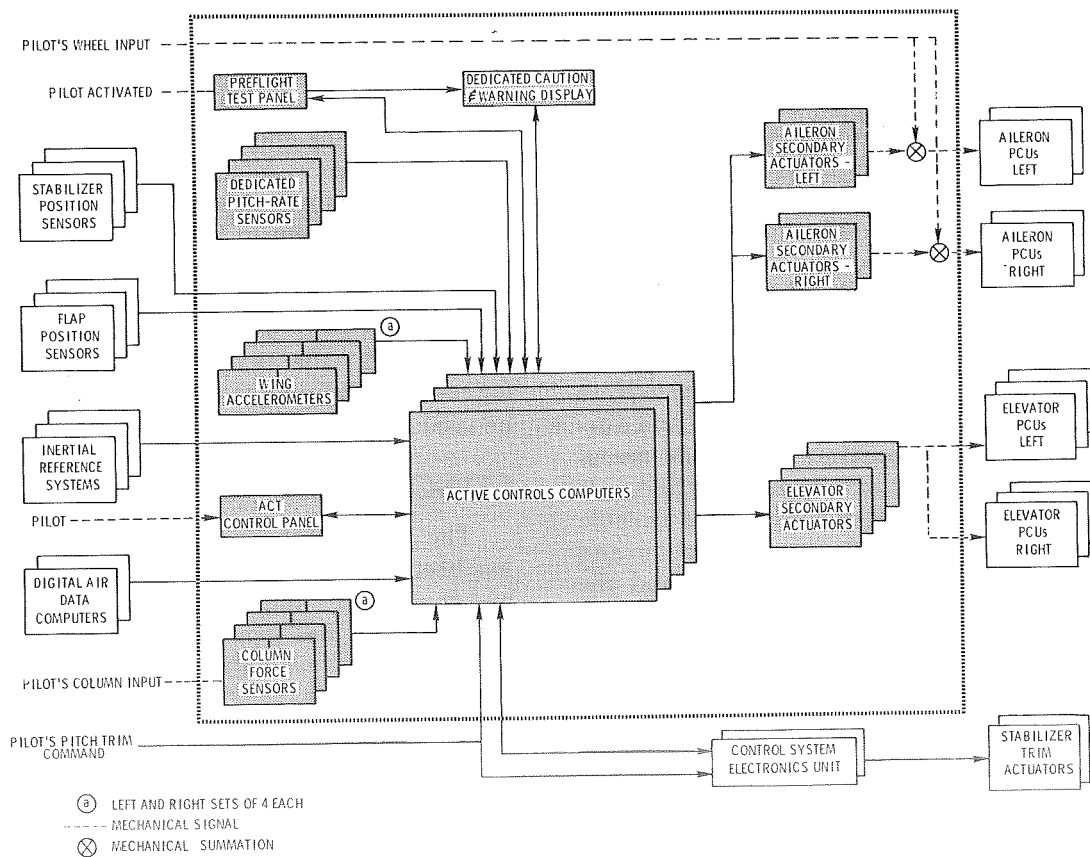

Figure 24. Boeing test ACT system architecture.

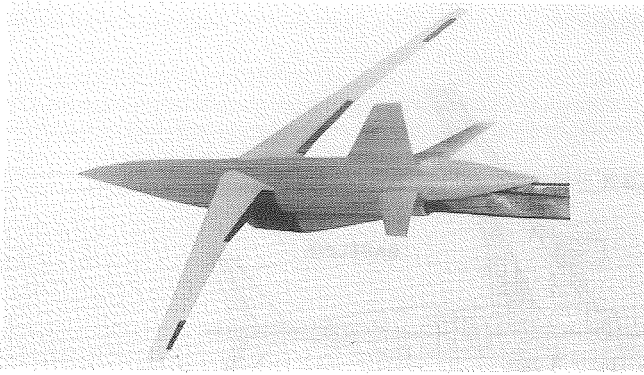

Figure 25. NASA aeroelastic research wing ARW-2 test model.

## Additional EET Studies

### IEM Study

Significant fuel savings can be achieved with a closed-loop integrated energy management (IEM) system involving an autothrottle or autopilot and on-board sensing of the aircraft's energy state. These potential savings, however, become a trade-off with other economic factors and constraints such as flight time or air traffic control (ATC) requirements.

Boeing conducted an IEM Study (ref. 60) involving (1) instrumentation of and data collection on a 727-200 that flew 80 revenue flights in the United Airlines network, (2) data reduction and development of IEM algorithms (organized into a model), and (3) verification of the model through simulation. For selected city pairs, IEM performance was compared with actual performance (using handbook reference data and conventional procedures and piloting techniques). Typical findings are illustrated in figure 26. In this example (roughly equivalent to a flight between Washington, DC and Chicago), a fuel saving of 5 percent was realized from using IEM procedures. Flight time, however, increased by 12.3 percent. Note that the most significant fuel difference occurred during descent where ATC constraints preclude use of optimum altitude, thrust, and speed schedules. It was thus concluded that IEM systems are feasible and practical for cruise, but may not be for climb and descent because of operational constraints and the necessity for storing large amounts of reference performance data in the IEM computers. It was found that this data storage is required because the aircraft's optimal energy state changes too rapidly during climb and descent to permit accurate calculation of a best altitude, thrust, and speed schedule.

### Longitudinal Handling Qualities

Like flight studies, high-fidelity simulation studies are relatively expensive and/or difficult to sched-

	117.6 NMI	387.6 NMI	88 NMI	TOTAL 593.1 NMI
<b>FUEL, LB</b>				
• CONVENTIONAL	3,601	6,333	817	10,751
• IEM	3,404	6,153	656	10,213
Δ	-197 (-5.5%)	-180 (-2.8%)	-161 (-19.7%)	-538 (-5.0%)
<b>TRIP TIME, MIN</b>				
• CONVENTIONAL	16.10	49.85	12.15	78.10
• IEM	17.02	54.57	16.10	87.68
Δ	+0.92	+4.72	+3.95	+9.58 (+12.3%)

Figure 26. Results of integrated energy management for a typical mission.

ule because they involve sophisticated facilities, require experienced pilots, and must be run in real time. Langley cosponsored an EET study (ref. 61) at Bolt, Beranek, and Newman Inc., to develop an analytical methodology to assess the longitudinal handling qualities of transport aircraft during landing approach. The methodology is based on closed-loop performance requirements and pilot work load rather than specific open-loop vehicle response characteristics. Consequently, the effects of external disturbances, control and display parameters, and inherent piloting limitations are considered in the development of an optimal control model.

The analytical procedure was used to predict pilot ratings for specific landing tasks in calm air and turbulence. A six-degree-of-freedom motion-base simulation was then performed by four pilots at Douglas. As shown in figure 27, trends in handling qualities are predicted, but actual pilot ratings tend to be much higher (poorer handling qualities) than predicted. Thus it was concluded that (without further work) the analytical scheme could be used for comparative purposes (or trends), but should not be used to establish absolute pilot ratings.

## CONCLUDING REMARKS

The Energy Efficient Transport (EET) Program has been a NASA/industry effort in which research was cooperative and, in most cases, highly focused. The program has generated a large data base for the design and evaluation of future energy efficient transport aircraft. In addition to the cited references, a comprehensive listing of published EET documents (with abstracts) is included as an appendix.

It appears that EET technology has advanced to the point that industry could produce a new airplane (circa 1990) that is at least 15 to 20 percent more fuel efficient than those currently in production. Then by including other advanced technologies such as com-

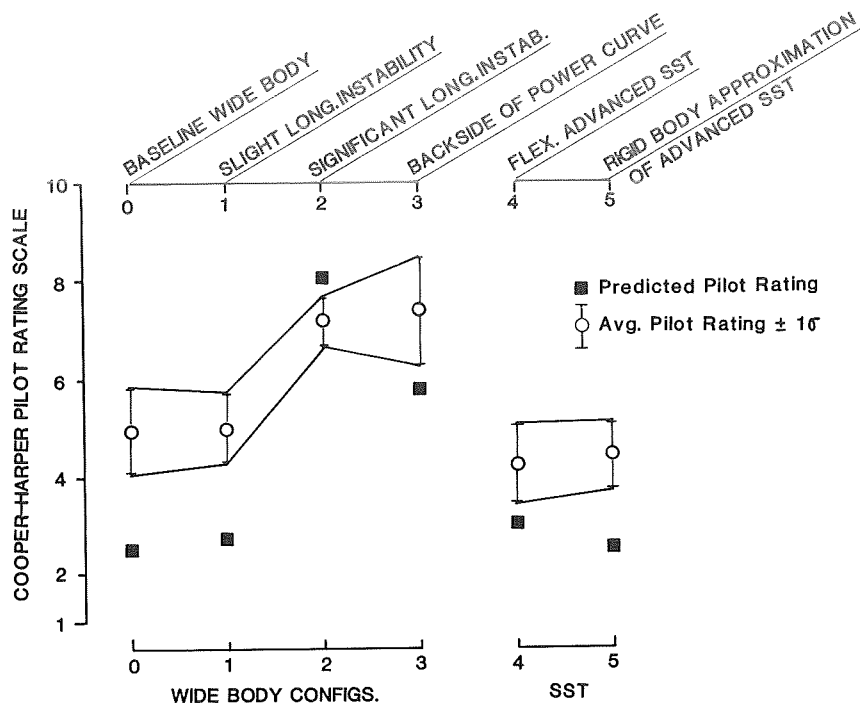

Figure 27. Comparison of predicted and pilot-rated handling qualities of several simulated transport aircraft.

posites and advanced propulsion systems, another large increment in fuel efficiency could be realized.

The implicit value of the EET Program has been to accelerate development and verification of EET-related technologies through free and rapid transfer of data and concepts between government and industry and among industry as well. Prompted by a common concern over fuel shortages, foreign competition, and profitable operations, the aircraft manufacturers, the airlines, NASA, and the FAA will continue to advance and validate new technologies for early commercial application.

NASA Langley Research Center  
Hampton, VA 23665  
March 14, 1985

## REFERENCES

- Staff, NASA Langley; and NASA Lewis Research Centers: Advanced Subsonic Transport Technology. *Astronaut. & Aeronaut.*, vol. 10, no. 8, Aug. 1972, pp 26-55.
- James, Robert L., Jr.; and Maddalon, Dal V.: The Drive for Aircraft Energy Efficiency. *Aerosp. America*, vol. 22, no. 2, Feb. 1984, pp. 54-58.
- Aiken, William S., Jr.; and Petersen, Richard H.: *ACEE Program Rationale and Implementation*. NASA TM-84549, 1982.
- Ethell, Jeffrey L.: *Fuel Economy in Aviation*. NASA SP-462, 1983.
- Whitcomb, Richard T.: Review of NASA Supercritical Airfoils. ICAS Paper No. 74-10, 1974.
- Harris, Charles D.: *Aerodynamic Characteristics of a 14-Percent-Thick NASA Supercritical Airfoil Designed for a Normal-Force Coefficient of 0.7*. NASA TM X-72712, 1975.
- Bartlett, Dennis W.; and Patterson, James C., Jr.: *NASA Supercritical-Wing Technology*. NASA TM-78731, 1978.
- Advanced Aerodynamics and Active Controls—Selected NASA Research*. NASA CP-2172, 1981.
- Advanced Aerodynamics—Selected NASA Research*. NASA CP-2208, 1981.
- Jacobs, Peter F.: *Experimental Trim Drag Values and Flow-Field Measurements for a Wide-Body Transport Model With Conventional and Supercritical Wings*. NASA TP-2071, 1982.
- Ray, Edward J.: A Review of Reynolds Number Studies Conducted in the Langley 0.3-m Transonic Crogenic Tunnel. AIAA-82-0941, June 1982.
- Steckel, Doris K.; Dahlin, John A.; and Henne, Preston A.: *Results of Design Studies and Wind Tunnel Tests of High-Aspect-Ratio Supercritical Wings for an Energy Efficient Transport*. NASA CR-159332, 1980.
- Henne, Preston A.; Dahlin, John A.; Peavey, Charles C.; and Gerren, Donna S.: *Configuration Design Studies and Wind Tunnel Tests of an Energy Efficient Transport With*

- With a High-Aspect-Ratio Supercritical Wing. NASA CR-3524, 1982.
14. Allen, John B.; Oliver, Wayne R.; and Spacht, Lee A.: *Wind Tunnel Tests of High-Lift Systems for Advanced Transports Using High-Aspect-Ratio Supercritical Wings*. NASA CR-3523, 1982.
  15. Whitcomb, Richard T.: *A Design Approach and Selected Wind-Tunnel Results at High Subsonic Speeds for Wing-Tip Mounted Winglets*. NASA TN D-8260, 1976.
  16. Flechner, Stuart G.; Jacobs, Peter F.: *Experimental Results of Winglets on First, Second, and Third Generation Jet Transports*. NASA TM-72674, 1978.
  17. *KC-135 Winglet Program Review*. NASA CP-2211, 1982.
  18. Douglas Aircraft Co.: *DC-10 Winglet Flight Evaluation*. NASA CR-3704, 1983.
  19. Boeing Commercial Airplane Co.: *Selected Advanced Aerodynamics and Active Controls Technology Concepts Development on a Derivative B-747 Aircraft—Summary Report*. NASA CR-3295, 1980.
  20. Boeing Commercial Airplane Co.: *Nacelle Aerodynamic and Inertial Loads (NAIL) Project—Summary Report*. NASA CR-3585, 1982.
  21. Boeing Commercial Airplane Co.: *Nacelle Aerodynamic and Inertial Loads (NAIL) Project—Test Report*. NASA CR-165760, 1981.
  22. Boeing Commercial Airplane Co.: *Nacelle Aerodynamic and Inertial Loads (NAIL) Project Final Technical Report—Energy Efficient Transport Program*. NASA CR-165807, 1982.
  23. Boeing Commercial Airplane Co.: *Aircraft Surface Coatings—Summary Report*. NASA CR-3661, 1983.
  24. Boeing Commercial Airplane Co.: *Natural Laminar Flow Airfoil Analysis and Trade Studies—Final Report*. NASA CR-159029, [1979.]
  25. Boeing Commercial Airplane Co.: *Hybrid Laminar Flow Control Study Final Technical Report—Energy Efficient Transport Program*. NASA CR-165930, 1982.
  26. Boeing Commercial Airplane Co.: *F-111 Natural Laminar Flow Glove Flight Test Data Analysis and Boundary Layer Stability Analysis*. NASA CR-166051, 1984.
  27. Wagner, Richard D.; and Fischer, Michael C.: Fresh Attack on Laminar Flow. *Aerosp. America*, vol. 22, no. 3, Mar. 1984, pp. 72-76.
  28. Boppe, Charles W.: *Transonic Flow Field Analysis for Wing-Fuselage Configurations*. NASA CR-3243, 1980.
  29. Boppe, C. W.; and Stern, M. A.: Simulated Transonic Flows for Aircraft with Nacelles, Pylons, and Winglets. AIAA-80-0130, Jan. 1980.
  30. Srokowski, A. J.; Lores, M. E.; and Aidala, P.: Numerical Aircraft Design Using 3-D Transonic Analysis With Optimization. Volume I, Executive Summary. AFWAL-TR-81-3091, Vol. I, U.S. Air Force, Aug. 1981. (Available from DTIC as AD A110 035.)
  31. Srokowski, A. J.; Lores, M. E.; Weed, R. A.; and Smith, P. R.: Numerical Aircraft Design Using 3-D Transonic Analysis With Optimization. Volume II, Part I: Transport Design. AFWAL-TR-81-3091, Vol. II, Pt. I, U.S. Air Force, Aug. 1981. (Available from DTIC as AD A110 231.)
  32. Aidala, P.: Numerical Aircraft Design Using 3-D Transonic Analysis With Optimization. Volume II, Part 2: Fighter Design. AFWAL-TR-81-3091, Vol. II, Pt. 2, U.S. Air Force, Aug. 1981. (Available from DTIC as AD A110 036.)
  33. Waggoner, Edgar G.: Computational Analysis for an Advanced Transport Configuration With Engine Nacelles. AIAA-83-1851, July 1983.
  34. Douglas Aircraft Co.: *Experimental Investigation of Elastic Mode Control on a Model of a Transport Aircraft*. NASA CR-3472, 1981.
  35. Nissim, E.; and Abel, I.: *Development and Application of an Optimization Procedures for Flutter Suppression Using the Aerodynamic Energy Concept*. NASA TP-1137, 1978.
  36. Abel, Irving; Perry, Boyd, III; and Newsom, Jerry R.: *Comparison of Analytical and Wind-Tunnel Results for Flutter and Gust Response of a Transport Wing With Active Controls*. NASA TP-2010, 1982.
  37. Johnston, J. F.; et al.: *Accelerated Development and Flight Evaluation of Active Controls Concepts for Subsonic Transport Aircraft. Volume I—Load Alleviation/Extended Span Development and Flight Test*. NASA CR-159097, 1979.
  38. Boeing Commercial Airplane Co.: *Integrated Application of Active Controls (IAAC) Technology to an Advanced Subsonic Transport Project—Longitudinal Handling Qualities Study of a Relaxed-Stability Airplane*. NASA CR-3660, 1983.
  39. Urie, D. M.; et al.: *Accelerated Development and Flight Evaluation of Active Controls Concepts for Subsonic Transport Aircraft. Volume II—Aft C.G. Simulation and Analysis*. NASA CR-159098, 1979.
  40. Guinn, Wiley A.: *Development and Flight Evaluation of an Augmented Stability Active Controls Concept*. NASA CR-165951, 1982.
  41. Guinn, Wiley A.; Willey, Craig S.; and Chong, Michael G.: *Extended Flight Evaluation of a Near-Term Pitch Active Controls System*. NASA CR-172266, 1983.
  42. Guinn, Wiley A.; Rising, Jerry J.; and Davis, Walt J.: *Development of an Advanced Pitch Active Control System for a Wide Body Jet Aircraft*. NASA CR-172277, 1984.
  43. Rising, Jerry J.: *Development of a Reduced Area Horizontal Tail for a Wide Body Jet Aircraft*. NASA CR-172278, 1984.
  44. Sizlo, T. R.; Berg, R. A.; and Gilles, D. L.: *Development of a Low-Risk Augmentation System for an Energy-Efficient Transport Having Relaxed Static Stability*. NASA CR-159166, 1979.
  45. Boeing Commercial Airplane Co.: *Integrated Application of Active Controls (IAAC) to an Advanced Subsonic Transport Project—Conventional Baseline Configuration Study, Final Report*. NASA CR-159248, 1980.
  46. Boeing Commercial Airplane Co.: *Integrated Application of Active Controls (IAAC) Technology to an Advanced Subsonic Transport—Project Plan*. NASA CR-3305, 1981.
  47. Boeing Commercial Airplane Co.: *Integrated Application of Active Controls (IAAC) Technology to an Advanced Subsonic Transport Project—Initial Act Configu-*



- ration Design Study, Summary Report. NASA CR-3304, 1980.
48. Boeing Commercial Airplane Co.: *Integrated Application of Active Controls (IAAC) Technology to an Advanced Subsonic Transport Project—Wing Planform Study and Final Configuration Selection, Summary Report*. NASA CR-3468, 1981.
  49. Boeing Commercial Airplane Co.: *Integrated Application of Active Controls (IAAC) Technology to an Advanced Subsonic Transport Project—Final Act Configuration Evaluation*. NASA CR-3519, 1982.
  50. Boeing Commercial Airplane Co.: *Integrated Application of Active Controls (IAAC) Technology to an Advanced Subsonic Transport Project—Current and Advanced Act Control System Definition, Study Summary Report*. NASA CR-3545, 1982.
  51. Boeing Commercial Airplane Co.: *Integrated Application of Active Controls (IAAC) Technology to an Advanced Subsonic Transport Project. ACT/Control/Guidance System Study—Volumes I and II, Final Report*. NASA CR-165963, 1982.
  52. Boeing Commercial Airplane Co.: *Integrated Application of Active Controls (IAAC) Technology to an Advanced Subsonic Transport Project—Test ACT System Description, Final Report*. NASA CR-172221, 1983.
  53. Goldberg, Jack; Kautz, William H.; Melliar-Smith, P. Michael; Green, Milton W.; Levitt, Karl N.; Schwartz, Richard L.; and Weinstock, Charles B.: *Development and Analysis of the Software Implemented Fault-Tolerance (SIFT) Computer*. NASA CR-172146, 1984.
  54. Smith, T. Basil, III; and Lala, Jaynarayan H.: *Development and Evaluation of a Fault-Tolerant Multiprocessor (FTMP) Computer. Volume I—FTMP Principles of Operation*. NASA CR-166071, 1983.
  55. Lala, Jaynarayan H.; and Smith, T. Basil, III: *Development and Evaluation of a Fault-Tolerant Multiprocessor (FTMP) Computer. Volume II—FTMP Software*. NASA CR-166072, 1983.
  56. Lala, Jaynarayan H.; and Smith, T. Basil, III: *Development and Evaluation of a Fault-Tolerant Multiprocessor (FTMP) Computer. Volume III—FTMP Test and Evaluation*. NASA CR-166073, 1983.
  57. Holt H. Milton: Validation Methods for Flight Crucial Systems. *SAE 1983 Transactions*, Section 4, Volume 92, Soc. Automot. Eng., Inc., c.1984, pp. 4.42-4.49. (Available as SAE Tech. Paper Ser. 831421.)
  58. Hays, A. P.; Beck, W. E.; Morita, W. H.; Penrose, B. J.; Skarshaug, R. E.; and Wainfan, B. S.: *Integrated Technology Wing Design Study*. NASA CR-3586, 1982.
  59. Murrow, H. N.; and Eckstrom, C. V.: Drones for Aerodynamic and Structural Testing (DAST)—A Status Report. AIAA Paper 78-1485, Aug. 1978.
  60. Boeing Commercial Airplane Co.: *Integrated Energy Management Study*. NASA CR-158980, [1978].
  61. Levison, William H.; and Rickard, William W.: *Analytical and Simulator Study of Advanced Transport Handling Qualities*. NASA CR-3572, 1982.

## APPENDIX

### BIBLIOGRAPHY OF EET REPORTS

The technical publications listed herein (with their abstracts) were generated in conjunction with the EET Program. Part of the reported work was accomplished under the direction of the NASA research divisions and part was contracted directly with industry, who in some cases shared in the cost (e.g., in technology areas having near-term commercial application). The publications are accordingly separated into three categories: (1) Program overviews, including EET and ACEE papers and contractor major summary reports; (2) government publications, including NASA formal reports, conference papers, proceedings, etc.; and (3) contractor publications, including NASA contractor reports, conference papers, journal articles, etc. Within these three sections, the documents are grouped into subsections according to subject matter and listed chronologically with each subsection. The subsection titles parallel the subject areas discussed in the text.

#### Program Overviews

1. *CTOL Transport Technology—1978*. NASA CP-2036, Part II, 1978.

Technology associated with advanced conventional takeoff and landing transport aircraft is discussed. Topics covered include: advanced aerodynamics and active controls; operations and safety; and advanced systems. Emphasis is placed on increased energy efficiency.

2. Leonard, Robert W.: *Fuel Efficiency Through New Airframe Technology*. NASA TM-84548, 1982.

In its Aircraft Energy Efficiency Program, NASA has expended approximately 200 million dollars toward development and application of advanced airframe technologies to United States commercial transports. United States manufacturers have already been given a significant boost toward early application of advanced composite materials to control-surface and empennage structures and toward selected applications of active controls and advanced aerodynamic concepts. In addition, significant progress in definition and development of innovative, but realistic, systems for laminar flow control over the wings of future transports has already been made.

3. Ethell, Jeffrey L.: *Fuel Economy in Aviation*. NASA SP-462, 1983.

With the advent of the global fuel crisis in the early 1970's, it became apparent that the continued utility and efficiency of U.S. aircraft could be severely affected by sharply rising fuel prices and potential shortages. Recognizing this situation, the U.S. Senate, in

January 1975, requested NASA to develop a program for Aircraft Energy Efficiency (ACEE) which would as rapidly as possible develop new structural, engine, aerodynamic, and control technologies for incorporation into future air transport industry designs. NASA responded with a program plan developed in conjunction with industry; Congress provided the funding, and the ACEE Program was launched in 1976. It was implemented in six parts: Engine Component Improvement, Energy Efficient Engine, Advanced Turboprop, Composite Primary Structures, Laminar Flow Control, and Energy Efficient Transport. The first three parts were managed by the Lewis Research Center in Cleveland, Ohio, and the other three were managed by the Langley Research Center in Hampton, Virginia.

This publication describes the ACEE Program and the impact that ACEE technologies will have on present and future aircraft. Chapter 6 deals with the Energy Efficient Transport. It covers advanced aerodynamics technologies such as high-aspect-ratio supercritical wings, airframe/engine integration, natural and hybrid laminar flow, winglets, advanced high-lift devices, and aircraft surface coatings. Chapter 6 also covers active controls technology development involving multiply redundant computer-sensor-actuator systems that provide artificial stability, active flutter suppression, wing load alleviation and integrated energy management. Flight tests were made to evaluate DC-10 winglets, 747 nacelle, pylon, and wing flight loads, and L-1011 wing load alleviation. Future flight tests are planned to verify and evaluate an integrated fly-by-wire implementation of active controls on a Boeing 757 or 767.

4. Middleton, David B.; Bartlett, Dennis W.; and Hood, Ray V.: *Energy Efficient Transport Technology in Hand*. *Aerosp. America*, vol. 22, no. 5, May 1984, pp. 74-78.

This, the third in a series of articles on NASA's Aircraft Energy Efficiency Program to develop fuel-conservation technology for commercial transports, describes important results for designers. James and Maddalon (February 1984 *Aerospace America*) surveyed the entire program (which began in 1970) and cited an extensive list of pertinent technical writings. Wagner and Fischer (March 1984 *Aerospace America*) summarized results of the effort on laminar flow control. The Energy Efficient Transport Program was charged with research in advanced aerodynamics and active controls, with the goal of increasing transport fuel efficiency by 15-20 percent. The project included both in-house activities and cost-shared contracts with Boeing, Douglas, and Lockheed, thereby leading to a strong and close relationship between NASA and industry that has rapidly transferred technology and accelerated its application.

5. James, Robert L., Jr.; and Maddalon, Dal V.: *Airframe Technology for Aircraft Energy Efficiency*. NASA TM-85749, 1984.

NASA's Aircraft Energy Efficiency (ACEE) Program began in 1976, following a year of planning. This half-billion dollar program focused on the development and demonstration of advanced technologies applicable primarily to transport aircraft, with about half the effort devoted to engine technology and the other half to the airframe. This paper reviews the economic factors that resulted in the implementation of the ACEE Program and discusses airframe technology elements including content, progress, applications, and future direction. The program includes the development of laminar flow systems, advanced aerodynamics, active controls, and composite structures.

### Boeing Programs

6. Hanks, Glen W.: Overview of Technology Advancements for Energy Efficient Transports. AIAA-79-1651, Aug. 1979.

Several research activities, conducted under NASA contract and directed toward improved fuel efficiency of commercial transports, are described. Emphasis is placed on advancements in aerodynamics and in avionics and controls. Aerodynamic advancements include wing geometry variations and the winglet concept for improved lift-to-drag ratio, improved high-lift design, evaluation of natural laminar flow for drag reduction, and improved surface coatings for reduced drag and surface erosion. Application of active controls; closed-loop flight path control using direct computer control of autopilot and autothrottle during ascent, cruise, and descent; and the use of delayed flap operation and precise flight path control in the terminal area are included as potential improvements that rely on advanced avionics and controls. Evaluation of potential applications is provided.

7. Hanks, Glen W.: Technology Advancements for Energy Efficient Transports. AIAA-80-0906, May 1980.

Ongoing government and industry supported research activities pertaining to improved fuel efficiency of commercial transports are described with particular attention to advancements in aerodynamics, avionics, and controls technologies. Emphasis is placed on the interaction of these technologies with the structure, propulsion, and other technologies involved in transport configuration design, as well as the impact on airline operation they could imply. The potential benefits offered by these technologies and the research activities required to support their commitment to future models are discussed.

8. Boeing Commercial Airplane Co.: *Selected Advanced Aerodynamic and Active Controls Technology Concepts Development on a Derivative B-747 Aircraft*.

A. *Final Report*. NASA CR-3164, 1980.

B. *Summary Report*. NASA CR-3295, 1980.

Analyses, conceptual design, and wind tunnel test evaluations covering the feasibility of applying wing-tip extensions, winglets, and active controls wing load alleviation to the Boeing 747 are described. Winglet aerodynamic design methods and high-speed wind tunnel test results of winglets and of symmetrically deflected ailerons are presented. Structural resizing analyses to determine weight and aeroelastic twist increments for all the concepts and flutter model test results for the wing with winglets are included. Control flutter law development, system mechanization and reliability studies, and aileron balance tab trade studies for active wing load alleviation systems are discussed. Results are presented in the form of incremental effects on  $L/D$ , structural weight, block fuel savings, stability and control, airplane price, and airline operating economics.

9. Boeing Commercial Airplane Co.: *Selected Advanced Aerodynamic and Active Control Development—Summary Report*. NASA CR-3220, 1980.

A summary is presented of results obtained during analysis, design, and test activities on six selected technical tasks directed at exploratory improvement of fuel efficiency for new and derivative transports. The work included investigations into the potential offered by natural laminar flow, improved surface coatings, and advanced high-lift concepts. Similar investigations covering optimum low-energy flight path control, integrated application of active controls, and evaluation of primary flight control systems reliability and maintenance are also summarized. Recommendations are included for future work needed to exploit potential advancements.

10. Boeing Commercial Airplane Co.: *Integrated Application of Active Controls (IAAC) Technology to Advanced Subsonic Transports—Project Plan*. NASA CR-3305, 1981.

This report briefly reviews the state of the art (1980) of active controls technology (ACT) and outlines a recommended ACT development program plan. The objectives of the recommended plan are to conduct a credible assessment of the performance benefits and cost of ownership of an integrated application of ACT to civil transport aircraft, to identify the risks, and to conduct selected laboratory and/or flight experiments designed to reduce the technical risks to a commercially acceptable level.

11. Boeing Commercial Airplane Co.: *Integrated Application of Active Controls (IAAC) Technology to an Advanced Subsonic Transport Project—Program Review*. NASA CR-3880, 1985.

This report summarizes the Integrated Application of Active Controls (IAAC) Technology to an Advanced Subsonic Transport Project, established as one element of the NASA/Boeing Energy Efficient Transport Technology Program. The IAAC Project was undertaken to

- Produce a credible assessment of the benefits associated with the design of a commercial transport airplane using Active Controls Technology (ACT).
- Identify technical risk areas and recommend test and development programs.
- Implement selected test and development programs.

The performance assessment showed that incorporating ACT into an airplane designed to fly approximately 200 passengers approximately 2000 nmi could yield block fuel savings from 6% to 10%, at the design range. The principal risks associated with incorporating these active controls functions into a commercial airplane are those involved with the ACT system implementation. The Test and Evaluation phase of the IAAC Project focused on the design, fabrication, and test a Test ACT System that implemented pitch axis fly-by-wire, pitch-axis augmentation, and wing load alleviation. The system was built to be flight worthy, and was planned to be experimentally flown on the 757. The system was installed in the Boeing Digital Avionics Flight Controls Laboratory (DAFCL), where open-loop hardware and software tests, and a brief examination of a direct-drive valve (DDV) actuation concept were accomplished. When it became clear that the project would not continue into a flight test phase, due to funding limitations, the detailed testing of the software necessary to support a flight test was eliminated.

The IAAC Project has shown that ACT can be beneficially incorporated into a commercial transport airplane. Based on the results achieved during the testing phase, there appears to be no fundamental reason(s) that would preclude the commercial application of ACT, assuming an appropriate development effort is included.

### Douglas Programs

12. Douglas Aircraft Co.: *Selected Advanced Aerodynamic and Active Control Concepts Development—Summary Report*. NASA CR-3469, 1981.

This report summarizes the results of several Energy Efficient Transport Program tasks performed by Douglas Aircraft Company, including (1) the design and

wind tunnel development of high-aspect-ratio supercritical wings, including investigation of the cruise speed regime and also high lift; (2) the preliminary design and evaluation of an aircraft combining a high-aspect-ratio supercritical wing with a winglet; and (3) active controls, including the determination of criteria, configuration, and flying qualities associated with augmented longitudinal stability of a level likely to be acceptable for the next generation transport, and the design of a practical augmentation system. The baseline against which the work was performed and evaluated was the Douglas DC-X-200 twin engine derivative of the DC-10 transport. The supercritical-wing development showed that the cruise and buffet requirements could be achieved and that the wing could be designed to realize a sizable advantage over today's technology. Important advances in high-lift performance were shown. The design study of an aircraft with supercritical wing and winglet suggested that advantages in weight and fuel economy could be realized. The study of augmented stability, conducted with the aid of a motion-base simulator, concluded that a negative static margin was acceptable for the baseline unaugmented aircraft. Simple control laws were found adequate to supply the required flying qualities for the augmented aircraft. Additional work related to active controls determined the performance and potential limitations of existing ailerons on the DC-10 transport when considered for use as a wing load alleviation device.

13. Taylor, A. B.: *Development of Selected Advanced Aerodynamics and Active Control Concepts for Commercial Transport Aircraft*. NASA CR-3781, 1984.

The report summarizes work done by Douglas Aircraft Company under the Energy Efficient Transport Project in the field of advanced aerodynamics and active controls. The project task selections focused on the investigation of long-duct nacelle shape variation on interference drag; the investigation of the adequacy of a simple control law for controlling the elastic modes of a wing; the development of the aerodynamic technology at cruise and low speed of high-aspect-ratio supercritical wings of high performance; and the development of winglets for a second generation jet transport. All the tasks involved analysis and substantial wind tunnel testing. The winglet program also included flight evaluation. It is considered that the technology base has been built for the application of high-aspect-ratio supercritical wings and for the use of winglets on second generation transports.

### Lockheed Programs

14. Lockheed-California Co.: *Summary Report—Accelerated Development and Flight Evaluation of Ac-*

*tive Control Concepts for Subsonic Transport Aircraft.* NASA CR-159148, 1979.

The flight test of active load alleviation and extended span for the L-1011 wide-body transport aircraft and the piloted simulation leading to use of active stability augmentation with a small tail and aft center of gravity are reported. The extended span showed the expected cruise drag reduction of 3 percent. The small tail is expected to reduce cruise drag by another 3 percent, and eventual use of more aft center of gravity with active stability augmentation will provide further fuel savings. The active load alleviation functions included maneuver load control (MLC) and elastic mode suppression (EMS), using symmetric motions of the outboard ailerons to reduce wing bending loads in maneuvers or long-term up- or down-drafts (MLC), and to damp wing bending motions in turbulence (EMS). A gust load alleviation function using the active horizontal tail to provide airplane pitch damping in turbulence was found unnecessary. The piloted simulation tests evaluated criteria for augmentation-on and augmentation-off flying qualities. A simple pitch control law was verified at neutral static margin. The simulation task established the basis for follow-on construction and flight testing of a small tail with active stability augmentation.

15. Guinn, Wiley A.: *Development of an Advanced Pitch Active Control System and a Reduced Area Horizontal Tail for a Wide Body Jet Aircraft—Executive Summary.* NASA CR-172283, 1984.

This report summarizes work that was accomplished toward development of an advanced pitch active controls system (PACS) and a reduced area horizontal tail for a wide-body jet transport (L-1011) with a flying horizontal stabilizer (see NASA CR-172277 and NASA CR-172278 (entries 104 and 55)). The advanced PACS control law design objectives were to provide satisfactory handling qualities for aft c.g. flight conditions to negative static stability margins of 10 percent and to provide good maneuver control column-force gradients for nonlinear stability flight conditions. Validity of the control laws was demonstrated by piloted flight simulation tests on the NASA Langley Visual/Motion Simulator. Satisfactory handling qualities were demonstrated to a negative 20-percent static stability margin. The PACS control laws were mechanized to provide the system architecture that would be suitable for an L-1011 flight test program to a negative stability margin of 3 percent, which represents the aft c.g. limits of the aircraft. Horizontal tails with area reduced 30 and 38 percent of the L-1011 standard tail area were designed, fabricated, and wind tunnel tested. Drag reductions and weight savings of the 30 percent smaller tail would provide a lift-to-drag ratio ( $L/D$ ) benefit of

about 2 percent and the 38 percent smaller tail  $L/D$  benefit would be about 3 percent. However, forward c.g. limitations would have to be imposed on the aircraft because the maximum horizontal tail lift goal was not achieved and sufficient aircraft nose-up control authority was not available. This limitation would probably not be required for a new aircraft design.

## Government Publications

### Advanced Aerodynamics

For related documents, see the entries in the next two subsections.

16. *Advanced Aerodynamics and Active Controls—Selected NASA Research.* NASA CP-2172, 1981.

Aerodynamic and active control concepts for application to commercial transport aircraft are discussed. Selected topics include in-flight direct strike lightning research, triply redundant digital fly-by-wire control systems, tail configurations, winglets, and the drones for aerodynamic and structural testing (DAST) program.

17. *Advanced Aerodynamics—Selected NASA Research.* NASA CP-2208, 1981.

This Conference Publication contains selected NASA papers that were presented at the Fifth Annual Status Review of the NASA Aircraft Energy Efficiency (ACEE) Energy Efficient Transport (EET) Program held at Dryden Flight Research Center in Edwards, California, on September 14-15, 1981. These papers describe the status of several NASA in-house research activities in the areas of advanced turboprops, natural laminar flow, oscillating control surfaces, high-Reynolds-number airfoil tests, high-lift technology, and theoretical design techniques.

18. Ray, Edward J.: *A Review of Reynolds Number Studies Conducted in the Langley 0.3-m Transonic Cryogenic Tunnel.* AIAA-82-0941, June 1982.

The 0.3-Meter Transonic Cryogenic Tunnel (TCT) was first placed in operation as a pilot transonic cryogenic wind tunnel at NASA Langley Research Center in 1973. As a result of its successful operation as the world's first transonic cryogenic pressure tunnel and its potential as a powerful new research tool, the pilot tunnel was later reclassified as a permanent facility. During the period of operation of the 0.3-m TCT, an emphasis has been placed on the determination of Reynolds number effects on a wide variety of both two-dimensional and three-dimensional configurations. This paper reviews some of the Reynolds number studies which have

been conducted in the 0.3-m TCT and presents selected highlights obtained from these investigations.

19. Johnson, William G., Jr.; Hill, Acquilla S.; Ray, Edward J.; Rozendaal, Roger A.; and Butler, Thomas W.: *High Reynolds Number Tests of a Boeing BAC I Airfoil in the Langley 0.3-Meter Transonic Cryogenic Tunnel*. NASA TM-81922, 1982.

A wind tunnel investigation of an advanced technology airfoil has been conducted in the Langley 0.3-Meter Transonic Cryogenic Tunnel (TCT). This investigation represents the first in a series of NASA/U.S. industry two-dimensional airfoil studies to be completed in the Advanced Technology Airfoil Test Program. Test temperature was varied from ambient to about 100 K at pressures ranging from about 1.2 to 6.0 atm. Mach number was varied from about 0.40 to 0.80. These variables provided a Reynolds number (based on airfoil chord) range from about  $4.4 \times 10^6$  to  $50.0 \times 10^6$ . This investigation was specifically designed to (1) test a Boeing advanced airfoil from low to flight-equivalent Reynolds numbers; (2) provide the industry participant (Boeing) with experience in cryogenic wind tunnel model design and testing techniques; and (3) demonstrate the suitability of the 0.3-m TCT as an airfoil test facility. All the objectives of the cooperative test were met. Data are included which demonstrate the effects of fixed transition, Mach number, and Reynolds number on the aerodynamic characteristics of the airfoil. Also included are remarks on the model design, the model structural integrity, and the overall test experience.

**High-aspect-ratio supercritical wings.** For related documents, see entries 37 and 46.

20. Bartlett, Dennis W.: *Wind-Tunnel Investigation of Several High-Aspect-Ratio Supercritical Wing Configurations on a Wide-Body-Type Fuselage*. NASA TM X-71996, 1977.

An investigation was conducted in the Langley 8-Foot Transonic Pressure Tunnel on two aspect-ratio-11.95 supercritical wings that were tested in combination with a representative wide-body-type fuselage. The two supercritical wings had identical planforms for equal sweep angles and differed only in thickness. Each wing was tested at quarter-chord sweep angles of 27° and 30°. At the higher sweep angle, the aspect ratio was reduced to 11.36. At 27° of quarter-chord sweep, the thicker supercritical wing (SCW-1) had maximum streamwise thickness-to-chord ratio of 0.16 at the wing-fuselage juncture, 0.14 at the planform break station, and 0.12 at the tip. The thinner wing (SCW-2) had maximum streamwise thickness-to-chord ratios of 0.144, 0.12, and 0.10 at the same stations. Tests were also

conducted on the thinner supercritical wing at the 27° sweep angle with a 15.24 cm (6.0 in.) shorter span which resulted in an aspect ratio of 10.25. For comparison, data were obtained on a current wide-body transport wing (AR=7) that was tested on the same fuselage used with the supercritical wings.

21. Bartlett, Dennis W.; and Patterson, James C., Jr.: *The NASA Supercritical-Wing Technology*. NASA TM-78731, 1978.

A number of high-aspect-ratio supercritical wings in combination with a representative wide-body-type fuselage were tested in the Langley 8-Foot Transonic Pressure Tunnel. The wing parameters investigated include aspect ratio, sweep, thickness-to-chord ratio, and camber. Subsequent to these initial tests, a particular wing configuration was selected for further study and development. Tests on the selected wing involved the incorporation of a larger inboard trailing-edge extension, an inboard leading edge extension, and flow-through nacelles. Range factors for the various supercritical-wing configurations are compared with those for a reference wide-body transport configuration.

22. Howard, Jenny M.; and Morgan Harry L., Jr.: *Pressure Distribution Data From Tests of Aspect-Ratio-10 EET High-Lift Research Model Equipped With Part- and Full-Span Flaps*. NASA TM-80082, 1979.

A wide-body jet transport model with an aspect-ratio-10 supercritical wing was tested in the Langley V/STOL Tunnel in support of the Energy Efficient Transport (EET) Project, which is an element of the Aircraft Energy Efficiency (ACEE) Program. The tabulated and plotted pressure distribution data for cruise, climb, takeoff, and landing wing configurations are presented. The wing was equipped with a full-span leading-edge slat and both part- and full-span double-slotted trailing-edge flaps. The data are presented without analysis or discussion.

23. Morgan, Harry L., Jr.: *Model Geometry Description and Pressure Distribution Data From Tests of EET High-Lift Research Model Equipped With Full-Span Slat and Part-Span Flaps*. NASA TM-80048, 1979.

A high-lift research model with a 3.66-m (12-ft) span and equipped with a full-span leading-edge slat and a part-span double-slotted trailing-edge flap was tested in the Langley V/STOL Tunnel to determine the low-speed performance characteristics of a representative high-aspect-ratio supercritical wing. These tests were performed in support of the Energy Efficient Transport (EET) Program, which is one element of the Aircraft Energy Efficiency (ACEE) Project. Static longitudinal

and lateral aerodynamic forces and moments and chordwise pressure distributions at three spanwise stations were measured for cruise, climb, takeoff, and landing wing configurations. This report contains a detailed description of the model geometry and the tabulated and plotted pressure distribution data for several runs that are representative of the various wing configurations tested. These pressure data are presented without analysis or discussion.

24. Morgan, Harry L., Jr.: *Supplemental Pressure Distribution Data From Tests of EET High-Lift Research Model Equipped With Full-Span Slat and Part-Span Flaps*. NASA TM-80049, 1979.

A high-lift research model with a 3.66-m (12-ft) span and equipped with a full-span leading-edge slat and a part-span double-slotted trailing-edge flap was tested in the Langley V/STOL Tunnel to determine the low-speed performance characteristics of a representative high-aspect-ratio supercritical wing. These tests were performed in support of the Energy Efficient Transport (EET) Program, which is one element of the Aircraft Energy Efficiency (ACEE) Project. Static longitudinal and lateral aerodynamic forces and moments and chordwise pressure distributions at three spanwise stations were measured for cruise, climb, takeoff, and landing wing configurations. This report contains supplemental tabulated and plotted pressure distribution data for 27 runs that are representative of the various wing configurations and test conditions tested during this investigation. These pressure data are presented without analysis or discussion.

25. Morgan, Harry L., Jr.; and Paulson, John W., Jr.: *Low-Speed Aerodynamic Performance of a High-Aspect-Ratio Supercritical-Wing Transport Model Equipped With Full-Span Slat and Part-Span Double-Slotted Flaps*. NASA TP-1580, 1979.

An investigation was conducted in the Langley V/STOL Tunnel to determine the static longitudinal and lateral-directional aerodynamic characteristics of an advanced high-aspect-ratio supercritical wing transport model equipped with a full-span leading-edge slat and part-span double-slotted trailing-edge flaps. This wide-body transport model was also equipped with spoiler and aileron control surfaces, flow-through nacelles, landing gear, movable horizontal tails, and interchangeable wing tips with aspect ratios of 10 and 12. The model was tested with leading-edge slat and trailing-edge flap combinations representative of cruise, climb, takeoff, and landing wing configurations. The tests were conducted at free-stream conditions corresponding to Reynolds numbers (based on mean geometric chord) of  $0.97 \times 10^6$  to  $1.63 \times 10^6$  and corresponding Mach numbers of 0.12 to 0.20, through an angle-of-

attack range from  $-2^\circ$  to  $24^\circ$  and a sideslip-angle range from  $-10^\circ$  to  $5^\circ$ .

26. Morgan, Harry L., Jr.: *Low-Speed Aerodynamic Performance of an Aspect-Ratio-10 Supercritical-Wing Transport Model Equipped With a Full-Span Slat and Part-Span and Full-Span Double-Slotted Flaps*. NASA TP-1805, 1981.

An investigation was conducted in the Langley 4-by 7-Meter Tunnel to determine the static longitudinal and lateral-directional aerodynamic characteristics of an advanced aspect-ratio-10 supercritical-wing transport model equipped with a full-span leading-edge slat as well as part-span and full-span trailing-edge flaps. This wide-body transport model was also equipped with spoiler and aileron roll control surfaces, flow-through nacelles, landing gear, and movable horizontal tails. Six basic wing configurations were tested: (1) cruise (slats and flaps nested), (2) climb (slats deflected and flaps nested), (3) part-span flap, (4) full-span flap, (5) full-span flap with low speed ailerons, and (6) full-span flap with high speed ailerons. Each of the four flapped wing configurations was tested with leading-edge slat and trailing-edge flaps deflected to settings representative of both takeoff and landing conditions. Tests were conducted at free stream conditions corresponding to Reynolds numbers of  $0.97 \times 10^6$  to  $1.63 \times 10^6$  and corresponding Mach numbers of 0.12 to 0.20, through an angle of attack range of  $4^\circ$  to  $24^\circ$ , and a sideslip angle range of  $-10^\circ$  to  $5^\circ$ . The part- and full-span wing configurations were also tested in ground proximity.

27. Sandford, Maynard C.; Ricketts, Rodney H.; and Watson, Judith J.: *Subsonic and Transonic Pressure Measurements on a High-Aspect-Ratio Supercritical Wing Model With Oscillating Control Surfaces*. NASA TM-83201, 1981.

A high-aspect-ratio supercritical wing with oscillating control surfaces is described. The semispan wing model was instrumented with 252 static orifices and 164 in situ dynamic-pressure gages for studying the effects of control-surface position and sinusoidal motion on steady and unsteady pressures. Data from the present test (this is the second in a series of tests on this model) were obtained in the Langley Transonic Dynamics Tunnel at Mach numbers of 0.60 and 0.78 and are presented in tabular form.

### *Winglets*

28. Jacobs, Peter F.; Flechner, Stuart G.; and Montoya, Lawrence C.: *Effect of Winglets on a First-*

*Generation Jet Transport Wing. I—Longitudinal Aerodynamic Characteristics of a Semispan Model at Subsonic Speeds.* NASA TN D-8473, 1977.

The effects of winglets and a simple wing-tip extension on the aerodynamic forces and moments and the flow-field cross-flow velocity vectors behind the wing tip of a first generation jet transport wing were investigated in the Langley 8-Foot Transonic Pressure Tunnel using a semispan model. The test was conducted at Mach numbers of 0.30, 0.70, 0.75, 0.78, and 0.80. At a Mach number of 0.30, the configurations were tested with combinations of leading- and trailing-edge flaps.

**29.** Montoya, Lawrence C.; Flechner, Stuart G.; and Jacobs, Peter F.: *Effect of Winglets on a First-Generation Jet Transport Wing. II—Pressure and Spanwise Load Distributions for a Semispan Model at High Subsonic Speeds.* NASA TN D-8474, 1977.

Pressure and spanwise load distributions on a first generation jet transport semispan model at high subsonic speeds are presented for the basic wing and for configurations with an upper winglet only, upper and lower winglets, and a simple wing-tip extension. Selected data are discussed to show the general trends and effects of the various configurations.

**30.** Montoya, Lawrence C.; Jacobs, Peter F.; and Flechner, Stuart G.: *Effect of Winglets on a First-Generation Jet Transport Wing. III—Pressure and Spanwise Load Distributions for a Semispan Model at Mach 0.30.* NASA TN D-8478, 1977.

Pressure and spanwise load distributions on a first generation jet transport semispan model at a Mach number of 0.30 are given for the basic wing and for configurations with an upper winglet only, upper and lower winglets, and a simple wing-tip extension. To simulate second-segment-climb lift conditions, leading- and/or trailing-edge flaps were added to some configurations.

**31.** Meyer, Robert R., Jr.: *Effect of Winglets on a First-Generation Jet Transport Wing. IV—Stability Characteristics for a Full-Span Model at Mach 0.30.* NASA TP-1119, 1978.

The static longitudinal and lateral-directional characteristics of a 0.035-scale model of a first-generation jet transport were obtained with and without upper winglets. The data were obtained for takeoff and landing configurations at a free-stream Mach number of 0.30. The results generally indicated that upper winglets had favorable effects on the stability characteristics of the aircraft.

**32.** Jacobs, Peter F.: *Effect of Winglets on a First-Generation Jet Transport Wing. V—Stability Characteristics of a Full-Span Wing With a Generalized Fuselage at High Subsonic Speeds.* NASA TP-1163, 1978.

The effects of winglets on the static aerodynamic stability characteristics of a KC-135A jet transport model at high subsonic speeds are presented. The investigation was conducted in the Langley 8-Foot Transonic Pressure Tunnel using 0.035-scale wing panels mounted on a generalized research fuselage. Data were taken over a Mach number range from 0.50 to 0.95 at angles of attack ranging from  $-12^\circ$  to  $20^\circ$  and sideslip angles of  $0^\circ$ ,  $5^\circ$ , and  $-5^\circ$ . The model was tested at two Reynolds number ranges to achieve a wide angle of attack range and to determine the effect of Reynolds number on stability. Results indicate that adding the winglets to the basic wing configuration produces small increases in both lateral and longitudinal aerodynamic stability and that the model stability increases slightly with Reynolds number. The winglets do increase the wing bending moments slightly, but the buffet onset characteristics of the model are not affected by the winglets.

**33.** Flechner, Stuart G.: *Effect of Winglets on a First-Generation Jet Transport Wing. VI—Stability Characteristics for a Full-Span Model at Subsonic Speeds.* NASA TP-1330, 1979.

A wind tunnel investigation to identify changes in stability and control characteristics of a model KC-135A due to the addition of winglets is presented. Static longitudinal and lateral-directional aerodynamic characteristics were determined for the model with and without winglets. Variations in the aerodynamic characteristics at various Mach numbers, angles of attack, and angles of sideslip are discussed. The effect of the winglets on the drag and lift coefficients are evaluated and the low-speed and high-speed characteristics of the model are reported.

**34.** Flechner, Stuart G.; and Jacobs, Peter F.: *Experimental Results of Winglets on First, Second, and Third Generation Jet Transports.* NASA TM-72674, 1978.

The results of wind tunnel investigations of winglets on four jet transport configurations are presented. Performance and wing root bending moment data were given. Additionally, detailed aerodynamic characteristics are presented at the design condition and also at several off-design conditions for one configuration. Results of the investigations indicate that the winglets improve the cruise lift-to-drag ratio between 4 and 8 percent. These data also show that the ratios of relative aerodynamic gain to relative structural weight penalty



for winglets are 1.5 to 2.5 times the ratios for wing-tip extensions. The comprehensive investigation of the effects of winglets indicated that winglets produce no adverse effects on buffet onset, lateral-directional stability, and aileron control effectiveness.

**35.** Montoya, Lawrence C.; Flechner, Stuart G.; and Jacobs, Peter F.: *Effect of an Alternate Winglet on the Pressure and Spanwise Load Distributions of a First-Generation Jet Transport Wing*. NASA TM-78786, 1978.

Pressure and spanwise load distributions on a first generation jet transport semispan model at subsonic speeds are presented. The wind tunnel data were measured for the wing with and without an alternate winglet. The results show that the winglet affected outboard wing pressure distributions and increased the spanwise loads near the tip.

**36.** *KC-135 Winglet Program Review*. NASA CP-2211, 1982.

A review of the results of a joint NASA/USAF program to develop and flight test winglets on a KC-135 aircraft was held at the Dryden Flight Research Center on September 16, 1981. This publication is a compilation of the results presented. The winglet development from concept through wind tunnel and flight tests is discussed. Predicted, wind tunnel, and flight test results are compared for the performance loads and flutter characteristics of the winglets. The flight test winglets had a variable winglet cant and incidence angle capability which enabled a limited evaluation of the effects of these geometry changes.

### Computational Aerodynamics

**37.** Waggoner, E. G.: *Computational Transonic Analysis for a Supercritical Transport Wing-Body Configuration*. AIAA-80-0129, Jan. 1980.

A small disturbance transonic analysis code coupled with a two-dimensional boundary-layer code has been used to calculate the flow field effects of a wing planform and root section changes on a supercritical wing-body transport configuration. In the early phase of the effort, the analysis code was modified to significantly improve the comparisons of experimental and computed wing pressure distributions on the current configurations. These modifications involved the global grid system spacing near the wing and the interpolation scheme for wing coordinates intermediate to the defining stations. Computations were performed on a baseline configuration and two variant configurations. The computed aerodynamic forces, aerodynamic moments,

and wing pressure distributions are compared with experimental data obtained from tests conducted in the Langley 8-Foot Transonic Pressure Tunnel. The comparisons show that the computational results are sensitive to subtle design modifications and that the code could be used as an effective guide during the design process for transport configurations.

**38.** Streett, Craig L.: *Viscous-Inviscid Interaction for Transonic Wing-Body Configurations Including Wake Effects*. *AIAA J.*, vol. 20, no. 7, July 1982, pp. 915-923. (Available as AIAA-81-1266.)

An existing three-dimensional compressible integral boundary-layer method was modified to account for mean dilatation effects, to model transition properly, and to provide better numerical stability near computational boundaries. Results of this method were compared with those from a three-dimensional finite-difference boundary-layer method on a difficult test case. An interaction procedure was developed to couple this integral method with a number of wing-alone and wing-body transonic potential codes to account for viscous effects. A strip wake model, including thickness and curvature effects, was developed and incorporated into this interaction procedure. Results from this procedure were compared with experimental data and results from previous procedures on test cases where viscous effects were large.

### Active and Highly Reliable Controls

See entry 16, for additional information.

**39.** Murray, Nicholas D.; Hopkins, Albert L.; and Wensley, John H.: *Highly Reliable Multiprocessors. Integrity in Electronic Flight Control Systems*, AGARD-AG-224, Apr. 1977, pp. 17-1-17-17.

Highly reliable fault-tolerant computer systems are discussed for use in flight-critical avionic and control systems of future commercial transport aircraft. Such aircraft are envisioned to have integrated systems, to be terminally configured, and to be equipped with fly-by-wire flight control systems, all of which require highly reliable, fault-tolerant computers. Two candidate computer architectures are identified as having the potential of satisfying the commercial transport aircraft requirements.

**40.** Murrow, H. N.; and Eckstrom, C. V.: *Drones for Aerodynamic and Structural Testing (DAST)—A Status Report*. AIAA-78-1485, Aug. 1978.

A program for providing research data on aerodynamic loads and active control systems on wings with supercritical airfoils in the transonic speed range is described. Analytical development, wind tunnel tests,

and flight tests are included. A Firebee II target drone has been modified for use as a flight test facility. The program currently includes flight experiments on two aeroelastic research wings. The primary purpose of the first flight experiment is to demonstrate an active control system for flutter suppression on a transport-type wing. Design and fabrication of the wing are complete and after installing research instrumentation and the flutter suppression system, flight testing is expected to begin in early 1979. The experiment on the second research wing—a fuel-conservative transport type—is to demonstrate multiple active controls systems including flutter suppression, maneuver load alleviation, gust load alleviation, and reduced static stability. Of special importance for this second experiment are the development and validation of integrated design methods which include the benefits of active controls in the structural design.

41. Bavuso, Salvatore J.: *Trends in Reliability Modeling Technology for Fault Tolerant Systems*. NASA TM-80089, 1979.

Reliability modeling for fault-tolerant avionic computing systems was developed. The modeling of large systems involving issues of state size and complexity, fault coverage, and practical computation was discussed. A novel technique which provides a tool for studying the reliability of systems with nonconstant failure rates is presented. The fault latency which may provide a method of obtaining vital latent fault data is measured.

42. ORI, Incorporated, compilers: *Validation Methods for Fault-Tolerant Avionics and Control Systems—Working Group Meeting I*. NASA CP-2114, 1979.

The proceedings of the first working group meeting on validation methods for fault-tolerant computer design are documented. The state of the art in fault-tolerant computer validation was examined in order to provide a framework for future discussions concerning research issues for the validation of fault-tolerant avionics and flight control systems. The development of positions concerning critical aspects of the validation process is covered.

43. Byrdsong, Thomas A.; and Brooks, Cuyler W., Jr.: *Wind-Tunnel Investigation of Longitudinal and Lateral-Directional Stability and Control Characteristics of a 0.237-Scale Model of a Remotely Piloted Research Vehicle With a Thick, High-Aspect-Ratio Supercritical Wing*. NASA TM-81790, 1980.

A 0.237-scale model of a remotely piloted research vehicle equipped with a thick, high-aspect-ratio supercritical wing was tested in the Langley 8-Foot Transonic Pressure Tunnel to provide experimental data for

a prediction of the static stability and control characteristics of the research vehicle as well as to provide an estimate of vehicle flight characteristics for a computer simulation program used in the planning and execution of specific flight-research missions. Data were obtained at a Reynolds number of  $16.5 \times 10^6$  per meter for Mach numbers up to 0.92. The results indicate regions of longitudinal instability; however, an adequate margin of longitudinal stability exists at a selected cruise condition. Satisfactory effectiveness of pitch, roll, and yaw control was also demonstrated.

44. Gault, James W.; Trivedi, Kishor S.; and Clary, James B., editors: *Validation Methods Research for Fault-Tolerant Avionics and Control Systems—Working Group Meeting II*. NASA CP-2130, 1980.

The validation process comprises the activities required to insure the agreement of system realization with system specification. A preliminary validation methodology for fault-tolerant systems is documented. A general framework for a validation methodology is presented along with a set of specific tasks intended for the validation of two specimen systems, Software Implemented Fault Tolerance (SIFT) and Fault-Tolerant Multiprocessor (FTMP). Two major areas of research are identified: first, those activities required to support the ongoing development of the validation process itself and, second, those activities required to support the design, development, and understanding of fault-tolerant systems.

45. Migneault, Gerard E.: *Software Reliability and Advanced Avionics. AFIPS Conference Proceedings, Volume 49—1980 National Computer Conference*, AFIPS Press, c.1980, pp. 715-720.

This paper proposes that software is becoming the most safety critical element of the highly reliable avionics systems which will be needed in civil transport aircraft of the future. The paper first discusses the pressures leading to the use of digital technology, especially computers with software, in future civil transport aircraft. The level of required reliability pertaining to safety is then determined, both as mandated by regulations and as observed in actual practice. Finally, advanced fault-tolerant computers are described. Their reliability is simply analyzed in order to determine the role software will play; it is critical. The level of software reliability required is then examined.

46. Anglin, Ernie L.; and Byrdsong, Thomas A.: *Wing Flap-Type Control Effectiveness and Effects of Control Hinge Gap Seals for a Supercritical Wing*. AIAA-82-0960, June 1982.

Wind tunnel tests were made to investigate the control effectiveness of wing trailing-edge flap-type aerodynamic controls for a supercritical wing. The tests determined the effects of spanwise flap control location, two different wing transition grit location patterns, the magnitude of angular control deflection, control hinge moments, and control hinge gap seals. Results show that the inboard flap position deflections caused interference rearward at the vertical tail and that all flap positions for deflections in one direction only caused interference at the horizontal tail at a higher than design Mach number. Changes in wing transition grit pattern caused significant changes to static longitudinal characteristics and longitudinal control effectiveness.

47. Abel, Irving; Perry, Boyd, III; and Newsom, Jerry R.: *Comparison of Analytical and Wind-Tunnel Results for Flutter and Gust Response of a Transport Wing With Active Controls*. NASA TP-2010, 1982.

Two flutter suppression control laws were designed and tested on a low-speed aeroelastic model of a DC-10 derivative wing. Both control laws demonstrated increases in flutter speed in excess of 25 percent above the passive wing flutter speed. In addition, one of the control laws was effective in reducing loads due to turbulence generated in the wind tunnel. The effect of variations in gain and phase on the closed-loop performance was measured and is compared with predictions. In general, both flutter and gust response predictions agree reasonably well with experimental data.

48. Perry, B., III: *Methodology for Determining Elevon Deflections To Trim and Maneuver the DAST Vehicle With Negative Static Margin*. NASA TM-84499, 1982.

The relationships between elevon deflection and static margin using elements from static and dynamic stability and control and from classical control theory are emphasized. Expressions are derived and presented for calculating elevon deflections required to trim the vehicle in 1g straight-and-level flight and to perform specified longitudinal and lateral maneuvers. Applications of this methodology are made at several flight conditions for the aeroelastic research wing (ARW-2). On the basis of these applications, it appears possible to trim and maneuver the vehicle with the existing elevons at -15 percent static margin.

## Contractor Publications

### Advanced Aerodynamics

For related documents, see entries 17-19, 32, 38, and the entries in the next six subsections.

49. Sullivan, R. L.: *The Size and Performance Effects of High Lift System Technology on a Modern Twin Engine Jet Transport*. AIAA-79-1795, Aug. 1979.

The energy and economic benefits of low-speed aerodynamic system technology applied to a modern 200-passenger, 2000-nmi range, twin-engine jet transport are reviewed. Results of a new method to design flap systems at flight Reynolds number are summarized. The study contains the airplane high-lift configuration drag characteristics and design selection charts showing the effect of flap technology on the airplane size and performance. The study areas include wing and flap geometry, climb and descent speed schedules with partial flap deflection, flap system technology, and augmented stability. The results compare the improvements in payload from a hot, high elevation airport.

50. Urie, D. M.; and Reaser, J. S.: *Aerodynamic Development of a Small Horizontal Tail for an Active Control Relaxed Stability Transport Application. A Collection of Technical Papers—AIAA/Atmospheric Flight Mechanics Conference for Future Space Systems*, Aug. 1979, pp. 224-231. (Available as AIAA-79-1653.)

Relaxed static stability (RSS) with active controls stability augmentation contributes to aircraft efficiency by permitting more aft center of gravity with reduced trim drag and/or by allowing a smaller horizontal tail with less parasite drag and weight. A small tail designed for derivative versions of the Lockheed L-1011 used state-of-the-art lifting surface definition methods. Low-speed and transonic wind tunnel data verifying theoretical predictions have been obtained. A minimum size tail for this application was obtained and design details required for maximum performance were identified. A configuration suitable for production has been defined and will be developed through prototype flight testing on an L-1011.

51. Boeing Commercial Airplane Co.: *High Lift Selected Concepts—Energy Efficient Transport Program*. NASA CR-159093, 1979.

Results of applying newly developed analytical and design techniques to the design of high-lift sections for flight conditions are described. Two new high-lift sections designed to flight conditions are defined. The influence of the design on transport sizing and economics is addressed.

52. Patel, S. P.; and Donelson, J. E.: *Final Report—Investigation of the Interference Effects of Mixed-Flow Long-Duct Nacelles on a DC-10 Wing*. NASA CR-159202, 1980.

Wind tunnel test results utilizing a 4.7-percent-scale semispan model in an 11-foot transonic wind tunnel are presented. A low-drag long-duct nacelle installation for the DC-10 jet transport was developed. A long-duct nacelle representative of a CF6-50 mixed-flow configuration was investigated on the DC-10-30. The results showed that the long-duct nacelle with the current production symmetrical pylon is a relatively low risk installation for the DC-10 aircraft. Tuft observations and analytical boundary-layer analysis confirmed that the flow on the nacelle afterbody was attached. A small pylon fairing was evaluated and found to reduce channel peak suction pressures and to result in a small drag improvement. The test also confirmed that the optimum nacelle incidence angle is the same as for the short-duct nacelle; thus the same engine mount as for the production short-duct nacelle can be used for the long-duct nacelle installation. Comparison of the inboard wing pylon nacelle channel pressure distributions, with flow-through and powered long-duct nacelles showed that the power effects did not change the flow mechanism; hence, power effects can be considered negligible.

53. Patel, S. P.; and Donelson, J. E.: *Long-Duct Nacelle Aerodynamic Development for DC-10 Derivatives*. NASA CR-159271, 1980.

The results are presented of a wind tunnel test utilizing a 4.7-percent-scale semispan model of the DC-10 in the Calspan 8-foot transonic wind tunnel. The effect of a revised long-duct nacelle shape on the channel velocities, the incremental drag relative to the baseline long-duct nacelle, and channel velocities for the baseline long-duct nacelle were determined and compared with data obtained at Ames. The baseline and the revised long-duct nacelles are representative of a CF6-50 mixed-flow configuration and were evaluated on a model of a proposed DC-10 stretched-fuselage configuration. The results showed that the revised long-duct nacelle has an appreciable effect on the inboard channel velocities, resulting in an increased channel Mach number. However, the pressure recovery on the nacelle afterbody was about the same for both nacelles. The lift curves for both long-duct nacelle configurations were the same. The channel pressures measured at Calspan were in good agreement with those measured at Ames for the baseline long-duct nacelle. The incremental drag for the revised nacelle was measured as two to four counts (three counts is approximately equal to one percent of the airplane drag) higher than that of the baseline long-duct nacelle.

54. Taylor, A. B.: *Selected Winglet and Mixed-Flow, Long-Duct Nacelle Development for DC-10 Derivative Aircraft—Summary Report*. NASA CR-3296, 1980.

The high-speed cruise drag effects of the installation of winglets or a wing-tip extension and a mixed-flow, long-duct nacelle are investigated. The winglet program utilized a 4.7-percent semispan model in an 8-foot transonic wind tunnel. Winglets provided approximately twice the cruise drag reduction of wing-tip extensions for about the same increase in bending moment at the wing-fuselage juncture. The long-duct nacelle interference drag program utilized the same model, without the winglets, in an 11-foot transonic wind tunnel. The long-duct nacelle, installed in the same position as the current short-duct nacelle and with the current production symmetric pylon, was a relatively low risk installation. A pylon with an additional small rearward fairing was also tested and showed some drag reduction potential over the current pylon.

55. Rising, Jerry J.: *Development of a Reduced Area Horizontal Tail for a Wide Body Jet Aircraft*. NASA CR-172278, 1984.

A research program was performed to develop a reduced area horizontal tail configuration for the L-1011 that would provide fuel savings of approximately 2 to 3 percent. The scope of the program included design criteria definition, aerodynamic analysis, tail configuration development, and wind tunnel tests.

Three planform configurations were evaluated: one with area reduced 38 percent and two with area reduced 30 percent relative to a Lockheed L-1011 standard tail. Principal planform parameters evaluated were aspect ratio and quarter-chord sweep angle. The airfoil parameters evaluated included camber, leading-edge radius, and thickness ratio. The L-1011 has a flying stabilizer with a geared elevator. Consequently, stabilizer/elevator throw was included in the evaluation.

High-speed wind tunnel tests showed drag reductions of approximately 10 percent for the 38 percent smaller tail and for the 30 percent smaller tail with the best airfoil. However, the tails did not achieve the low-speed maximum lift characteristics required for the L-1011 without resorting to sophisticated high-lift devices. Thus, a forward c.g. limitation would have to be imposed on the airplane. On a new aircraft design, optimum landing gear location, controlled c.g. range, and increased stabilizer/elevator could possibly solve the lift-deficiency problem, and it would be feasible to utilize the small tail to realize significant fuel savings.

#### *High-aspect-ratio supercritical wings*

56. Oliver, Wayne R.: *Results of Design Studies and Wind Tunnel Tests of an Advanced High Lift System for an Energy-Efficient Transport*. NASA CR-159389, 1980.

The development of an advanced technology high-lift system for an energy efficient transport incorporating a high-aspect-ratio supercritical wing is described. This development is based on the results of in-house trade studies to select the high-lift system, analysis techniques utilized to design the high-lift system, and results of a wind tunnel test program. Part of this experimental program included the first experimental low-speed, high Reynolds number wind tunnel test for this class of aircraft. The experimental results included the effects on low-speed aerodynamic characteristics of various leading- and trailing-edge devices, nacelles and pylons, aileron, spoilers, Mach and Reynolds numbers. Results of this test program are discussed and comparisons are made between the experimental data and analytical estimates of the various aerodynamic characteristics.

57. Steckel, Doris K.; Dahlin, John A.; and Henne, Preston A.: *Results of Design Studies Wind Tunnel Tests of High-Aspect-Ratio Supercritical Wings for an Energy Efficient Transport*. NASA CR-159332, 1980.

This report presents the results of design studies and wind tunnel tests of high-aspect-ratio supercritical wings suitable for a medium-range, wide-body transport aircraft flying near  $M = 0.80$ . The basic characteristics of the wings tested were derived from system studies of advanced transport aircraft where detailed structural and aerodynamic trade-offs were used to determine the most optimum design from the standpoint of fuel usage and direct operating cost. These basic characteristics included wing area, aspect ratio, average thickness, and sweep as well as practical constraints on the planform and thickness near the wing root to allow for the landing gear. Within these constraints, a large matrix of wing designs was studied with spanwise variations in the types of airfoils and distribution of lift as well as some small planform changes. The criteria by which the five candidate wings were chosen for testing were the cruise and buffet characteristics in the transonic regime and the compatibility of the design with low-speed (high-lift) requirements. Five wing-wide-body configurations were tested in the NASA Ames 11-Foot Transonic Wind Tunnel over a 1-year period starting in May 1978. Nacelles and pylons, flap support fairings, tail surfaces, and an outboard aileron were also tested on selected configurations. Results of these tests showed that the cruise and buffet characteristics used in the system studies could be achieved and that the high-aspect-ratio supercritical wing can be designed to realize a sizable advantage over today's technology in terms of fuel usage and economics. For the configuration studied, these gains amount to a reduction of over 5 percent in direct operating cost. The results also show that such gains are achievable only

when considerable attention is given to the details of the wing design.

58. Allen, John B.; Oliver, Wayne R.; and Spacht, Lee A.: *Wind Tunnel Tests of High-Lift Systems for Advanced Transports Using High-Aspect-Ratio Supercritical Wings*. NASA CR-3523, 1982.

The wind tunnel testing of an advanced technology high-lift system for a wide-body and a narrow-body transport incorporating high-aspect-ratio supercritical wings is described. This testing has added to the very limited low-speed, high Reynolds number data base for this class of aircraft. The experimental results included the effects on low-speed aerodynamic characteristics of various leading- and trailing-edge devices, nacelles and pylons, ailerons, and spoilers, and the effects of Mach and Reynolds numbers.

59. Henne, Preston A.; Dahlin, John A.; Peavey, Charles C.; and Gerren, Donna S.: *Configuration Design Studies and Wind Tunnel Tests of an Energy Efficient Transport With a High-Aspect-Ratio Supercritical Wing*. NASA CR-3524, 1982.

This report presents the results of design studies and wind tunnel tests of high-aspect-ratio supercritical wings suitable for a medium-range, narrow-body transport aircraft flying near  $M = 0.80$ . The basic characteristics of the wing design were derived from system studies of advanced transport aircraft where detailed structural and aerodynamic trade-offs were used to determine the most optimum design from the standpoint of fuel usage and direct operating cost. These basic characteristics included wing area, aspect ratio, average thickness, and sweep. The detailed wing design was accomplished through application of previous test results and advanced computational transonic flow procedures. In addition to the basic wing-body development, considerable attention was directed to nacelle and pylon location effects, horizontal tail effects, and boundary-layer transition effects. Results of these tests showed that the basic cruise performance objectives were met or exceeded and that the high-aspect-ratio supercritical wing can be designed to realize a sizable advantage over conventional aircraft wings in terms of fuel usage.

*Winglets*. For related documents, see entries 8, 54, and 82.

60. Gilkey, R. D.: *Design and Wind Tunnel Tests of Winglets on a DC-10 Wing*. NASA CR-3119, 1979.

Results are presented of a wind tunnel test utilizing a 4.7-percent-scale semispan model in the Langley 8-Foot Transonic Pressure Tunnel to establish the cruise drag improvement potential of winglets applied to the

DC-10 wide-body transport aircraft. Winglets were investigated on both the DC-10 Series 10 (domestic) and Series 30/40 (intercontinental) configurations and compared with the Series 30/40 configuration. The results of the investigation confirm that for the DC-10, winglets provide approximately twice the cruise drag reduction of wing-tip extensions for about the same increase in bending moment at the wing-fuselage juncture. Furthermore, the winglet configurations achieved drag improvements which were in close agreement with analytical estimates. It was observed that relatively small changes in wing-winglet tailoring effected large improvements in drag and visual flow characteristics on the wing and winglets.

61. Shollenberger, C. A.: *Application of an Optimized Wing-Winglet Configuration to an Advanced Commercial Transport*. NASA CR-159156, 1979.

The design is presented of an aircraft which employs an integrated wing and winglet lift system. Comparison was made with a conventional baseline configuration employing a high-aspect-ratio supercritical wing. An optimized wing-winglet combination was selected from four proposed configurations for which aerodynamic, structural, and weight characteristics were evaluated. Each candidate wing-winglet configuration was constrained to the same induced drag coefficient as the baseline aircraft. The selected wing-winglet configuration was resized for a specific medium-range mission requirement, and operating costs were estimated for a typical mission. Study results indicated that the wing-winglet aircraft was lighter and could complete the specified mission at less cost than the conventional wing aircraft. These indications were sensitive to the impact of flutter characteristics and, to a lesser extent, to the performance of the high-lift system. Further study in these areas is recommended to reduce uncertainty in future development.

62. Douglas Aircraft Co.: *DC-10 Winglet Flight Evaluation*.

A. NASA CR-3704, 1983.

B. Taylor, A. B.: *Summary Report*. NASA CR-3748, 1983.

These reports present the results of a flight evaluation of winglets on a DC-10 Series 10 aircraft. For sensitive areas of comparison, effects of winglets were determined back-to-back with and without winglets. Basic and reduced-span winglet configurations were tested. After initial encounter with low-speed buffet, a number of acceptable configurations were developed. For maximum drag reduction at both cruise and low speeds, lower winglets were required, having leading-edge devices on upper and lower winglets for the latter

regime. The cruise benefits were enhanced by adding outboard aileron droop to the reduced-span winglet aircraft. Winglets had no significant impact on stall speeds, high-speed buffet boundary, or stability and control characteristics. Flutter test results agreed with predictions and ground vibration data. Flight loads measurement, provided in a concurrent Douglas program, also agreed with predictions.

It was estimated from the results that a production version of the aircraft, using the reduced-span winglet and aileron droop, would yield a 3-percent reduction in fuel burned at the range with capacity payload. This range was 2 percent greater than without winglets. A 5-percent reduction in takeoff distance at maximum takeoff weight would also result.

63. Shollenberger, Carl A.; Humphreys, John W.; Heiberger, Frank S.; and Pearson, Robert M.: *Results of Winglet Development Studies for DC-10 Derivatives*. NASA CR-3677, 1983.

The results of investigations into the application of winglets to the DC-10 aircraft are presented. The DC-10 winglet configuration was developed and its cruise performance determined in a previous investigation. This study included high-speed and low-speed wind tunnel tests to evaluate aerodynamic characteristics and a subsonic flutter wind tunnel test with accompanying analysis and evaluation of results. Additionally, a configuration integration study employed the results of the wind tunnel studies to determine the overall impact of the installation of winglets on the DC-10 aircraft. Conclusions derived from the high-speed and low-speed tests indicate that the winglets had no significant effects on the DC-10 stability characteristics or high-speed buffet. It was determined that winglets had a minimal effect on aircraft lift characteristics and improved the low-speed aircraft drag under high-lift conditions. The winglets affected the DC-10 flutter characteristics by reducing the flutter speed of the basic critical mode and introducing a new critical mode involving outer wing torsion and longitudinal bending. The overall impact of winglets was determined to be of sufficient benefit to merit flight evaluation.

#### *Nacelle Aerodynamic and Inertial Loads (NAIL)*

64. Martin, R. L.; and Olsson, W. J.: *Operating Flight Loads and Their Effect on Engine Performance*. SAE Paper 811071, Oct. 1981.

Engine diagnostic studies revealed that the primary causes of deterioration in the performance of high bypass turbofan engines are flight loads, erosion, and thermal distortion. This paper examines airplane loads that

are imposed on the engine and the response of the engine to these loads. The effects of nacelle angle of attack, airplane speed, and engine airflow are discussed. It was concluded that aerodynamic loads and differential thermal expansion are the main contributors to performance loss due to loads. Integrated engine and nacelle designs are recommended.

65. Boeing Commercial Airplane Co.: *Nacelle Aerodynamic and Inertia Loads (NAIL) Project*.

A. *Test Report*. NASA CR-165760, 1981.

B. *Final Technical Report*. NASA CR-165807, 1982.

C. *Summary Report*. NASA CR-3585, 1982.

A flight test survey of pressures measured on wing, pylon, and nacelle surfaces and of the operating loads on Pratt & Whitney JT9D-7A nacelles on a Boeing 747 was made to provide information on airflow patterns surrounding the propulsion system installations and to clarify processes responsible for in-service deterioration of fuel economy. Inlet air loads were measured by integration of pressures recorded at 252 locations on the right-hand inboard nacelle. Pressures were recorded at 45 locations on the right-hand outboard nacelle for comparison. Inertial loads were measured on both nacelles using accelerometers and rate gyros. Flight conditions included take-offs at several gross weights, high-*g* turns, and a simulated acceptance flight.

Air loads at take-off rotation were found to be larger than at any other normal service condition because of the combined effects of high angle of attack and high engine airflow. Inertial loads were smaller than previous estimates had indicated. A procedure is given for estimating inlet air loads at low speeds and high angles of attack for any underwing, high bypass ratio turbofan installation approximately resembling the one tested. Flight procedure modifications are suggested that may result in better fuel economy retention in service.

Pressures were recorded on the core cowls and pylons of both engine installations and on adjacent wing surfaces for use in development of computer codes for analysis of installed propulsion system aerodynamic drag interference effects.

66. Olsson, W. J.: *Performance Deterioration Due to Acceptance Testing and Flight Loads; JT9D Jet Engine Diagnostics Program*. NASA CR-165572, 1982.

This document presents the results of a Flight Loads Test of the JT9D-7 engine which was the final phase of the NASA JT9D Jet Engine Diagnostics Program. The objectives of this test program were to measure aerodynamic and inertia loads on the engine during flight, ex-

plore the effects of airplane gross weight and typical maneuvers on these flight loads, simultaneously measure the changes in engine running clearances and performance resulting from the maneuvers, make refinements of engine performance deterioration prediction models based on analytical results of the tests, and make recommendations to improve propulsion system performance retention. The test program was conducted as a joint effort with the Boeing Commercial Airplane Company. Boeing provided the test airplane and made the flight loads measurements. Pratt & Whitney Aircraft provided the instrumented engines and made the engine clearance and performance measurements. The test program included a typical production airplane acceptance test plus additional flights and maneuvers to encompass the range of flight loads in revenue service. The test results indicated that aerodynamic loads, primarily at take-off, were the major cause of rub-induced deterioration in the cold section of the engine. Differential thermal expansion between rotating and static parts plus aerodynamic loads combined to cause blade-to-seal rubs in the turbine.

67. Olsson, W. J.; and Martin, R. L.: *B747/JT9D Flight Loads and Their Effect on Engine Running Clearances and Performance Deterioration; BCAC NAIL/ &WA JT9D Engine Diagnostics Programs*. NASA CR-165573, 1982.

The joint Pratt & Whitney Aircraft/Boeing Commercial Airplane Company Flight Loads Test was the final phase of the NASA-sponsored JT9D Jet Engine Diagnostics Program. Prior test and analysis effort had identified a short-term engine performance deterioration mode which appeared to occur during pre-delivery production airplane acceptance testing and in initial revenue service flights. This test program duplicated the airplane acceptance testing and representative flight loads which might be incurred in revenue service. Boeing conducted the test in a 747 airplane which was instrumented to measure flight conditions, flight loads on the airplane and test engines, and engine performance. Pratt & Whitney Aircraft provided the instrumented test engines and monitored the effects of engine power settings and flight conditions on engine running clearances, blade-to-seal rubs, and resultant performance deterioration. The test results confirmed the significance of acceptance testing on performance deterioration and identified some approaches to improve performance retention.

#### *Aircraft surface coatings*

68. Boeing Commercial Airplane Co.: *Aircraft Surface Coatings Study—Energy Efficient Transport Program*. NASA CR-158954, 1979.

Surface coating materials, for application on transport-type aircraft to reduce drag, were investigated. The investigation included two basic types of materials: spray-on coatings and adhesively bonded films. A cost and benefits analysis was performed, and recommendations were made for future work toward the application of this technology.

**69.** Boeing Commercial Airplane Co.: *Aircraft Surface Coatings Study—Verification of Selected Materials—Energy Efficient Transport Program*. NASA CR-159288, 1980.

A previous study, reported in NASA CR-158954 (entry 68), identified three liquid coatings and four films that might improve and/or maintain the smoothness of transport aircraft surfaces. Laboratory tests were performed on the liquid coatings (elastomeric polyurethanes) exposed to synthetic-type hydraulic fluid, with and without a protective topcoat. Results were analyzed of a 14-month flight service evaluation of coatings applied to leading edges of an airline 727. Two additional airline service evaluations were initiated. Laboratory tests were conducted on the films, bonded to aluminum substrate with various adhesives, to determine the best film and adhesive combinations.

A cost and benefit analysis was performed and recommendations made for future work toward the application of this technology to commercial transports.

**70.** George-Falvy, Dezso; and Sikavi, Danny A.: *Flight Test Evaluation of Drag Effects on Surface Coatings on the NASA Boeing 737 TCV Airplane*. D6-37256 (Contract NAS1-15325), Boeing Co., June 1981. (Available as NASA CR-165767.)

A flight test program was conducted in which the effects of various surface coatings on aerodynamic drag were investigated; results of this program are described in this report. The tests were conducted at NASA Langley Research Center on the terminal configured vehicle (TCV) Boeing 737 research airplane. The Boeing Company, as contractor with NASA under the Energy Efficient Transport (EET) Program (Contract NAS1-15325), planned and evaluated the experiment. The NASA-TCV Program Office coordinated the experiment and performed the flight tests. The principal objective of the test was to evaluate the drag reduction potential of an elastomeric polyurethane surface coating, CAAPCO B-274, which also has been considered for application on transport airplanes to protect leading edges from erosion.

The drag was evaluated from boundary-layer measurements made at the downstream end of a 2 m (80 in.) wide test surface on the inboard portion of the wing. Measurements were taken simultaneously on both the

left and the right wing panel. Various surface coatings were applied to the left wing test section in a series of test flights, while the right wing test section remained bare metal, stripped of paint, to provide a constant basis of comparison.

**71.** Boeing Commercial Airplane Co.: *Aircraft Surface Coatings—Energy Efficient Transport Program*. NASA CR-165928, 1982.

Liquid, spray-on elastomeric polyurethanes were selected from previous work (reported in NASA CR-158954 and CR-159288 (entries 68 and 69)) as best candidates for aircraft external protective coatings. Flight tests were conducted to measure drag effects of these coatings compared with paints and a bare metal surface. The durability of two elastomeric polyurethanes, CAAPCO B-274 and Chemglaze M313, was assessed in airline flight service evaluations. Laboratory tests were performed to determine corrosion protection properties, compatibility with aircraft thermal anti-icing systems, the effect of coating thickness on erosion durability, and the erosion characteristics of bare and coated composite leading edges.

A cost and benefit assessment was made to determine the economic value of various coating configurations to the airlines.

**72.** Kreitinger, Richard L.; and Middleton, David B.: *Aircraft Surface Coatings for Drag Reduction/Erosion Protection*. *SAE 1981 Transactions, Section 4, Volume 90*, Soc. Automot. Eng., Inc., c.1982, pp. 3477-3491. (Available as SAE Tech. Paper Ser. 811070.)

Several films and spray-on coating materials were investigated to find a smooth, durable coating that would reduce the drag of commercial transports and that would protect the substrate from erosion and corrosion. Two elastomeric polyurethane spray-on coatings were subjected to flight service evaluations on airline transports. Flight test drag measurements showed that the coatings reduced drag compared with some current surface treatments.

**73.** Boeing Commercial Airplane Co.: *Aircraft Surface Coatings—Summary Report*. NASA CR-3661, 1983.

This report summarizes the work reported in entries 68-71 above. Films and liquid spray-on materials were evaluated in the laboratory for transport aircraft external surface coatings. Elastomeric polyurethanes were found to best meet requirements. Two commercially available products, CAAPCO B-274 and Chemglaze M313, were subjected to further laboratory testing, airline service evaluations, and drag-measurement flight



tests. It was found that these coatings were compatible with the severe operating environment of airlines and that coatings reduced airplane drag. An economic analysis indicated significant dollar benefits to airlines from application of the coatings.

### *Laminar flow*

74. Boeing Commercial Airplane Co.: *Natural Laminar Flow Airfoil Analysis and Trade Studies—Final Report*. NASA CR-159029, [1979].

An analysis of an airfoil for a large commercial transport cruising at Mach 0.8 and the use of advanced computer techniques to perform the analysis are described. Incorporation of the airfoil into a natural laminar flow transport configuration is addressed and a comparison of fuel requirements and operating costs between the natural laminar flow transport and an equivalent turbulent flow transport is addressed.

75. Boeing Commercial Airplane Co.: *Hybrid Laminar Flow Control Study Final Technical Report—Energy Efficient Transport Program*. NASA CR-165930, 1982.

The hybrid laminar flow control (HLFC) concept was examined in which leading-edge suction is used in conjunction with wing pressure distribution tailoring to postpone boundary-layer transition and reduce friction drag. A parametric study was conducted to determine airfoil design characteristics required for laminar flow control (LFC). The aerodynamic design of an HLFC wing for a 178-passenger commercial turbofan transport was developed, and a drag estimate was made. Systems changes required to install HLFC were defined, and weights and fuel economy were estimated. The potential for 9 percent fuel reduction for a 3926-km (2120-nmi) mission was identified.

76. Boeing Commercial Airplane Co.: *F-111 Natural Laminar Flow Glove Analysis*. NASA CR-166051, 1984.

This report contains an analysis of 34 selected flight test data cases from a NASA flight program incorporating a natural laminar flow airfoil into partial wing gloves on the F-111 TACT airplane. This analysis determined the measured location of transition from laminar to turbulent flow. The report also contains the results of a boundary-layer stability analysis of 25 of the selected cases in which the crossflow (C-F) and Tollmien-Schlichting (T-S) disturbance amplification factors were correlated with the measured transition location. The chord Reynolds numbers for these cases ranged from about 23 million to 29 million, the Mach numbers ranged from 0.80 to 0.85, and the glove leading-edge sweep angles ranged from 9° to 25°. The results indicate that the maximum extent of laminar flow varied

from 56 percent chord at 9° sweep to 21 percent chord at 25° sweep on the upper surface, and from 51 percent chord at 16° sweep to 6 percent chord at 25° sweep on the lower surface. The results of the boundary-layer stability analysis indicate that when both C-F and T-S disturbances are amplified, an interaction takes place that reduces the maximum amplification factor of either type of disturbance that can be tolerated without causing transition.

### *Computational methodology*

77. Boppe, C. W.: *Calculation of Transonic Wing Flows by Grid Embedding*. AIAA-77-207, Jan. 1977.

This paper describes a new approach to the calculation of three-dimensional inviscid transonic flows. The computational procedure, which employs a finite difference relaxation scheme, differs from existing methods in two ways: first, by choice of the flow governing equation and, second, by a technique for embedding one computational grid structure within another. Fine mesh calculations are performed only in regions near the wing where gradients are large and details are important. This results in improved computational resolution and reduced computing time, as compared with current methodology. In addition, the approach does not require global geometry fitting coordinate transformations. These features provide flexibility for treating complex three-dimensional geometries which, to date, have been impractical or impossible to compute. Sample calculations for airfoils, wings, and canard-wing combinations are included.

Computed pressure distributions are correlated with experimental values for two wings, one at Mach 0.84 at an angle of attack of 3°, and the other at Mach 0.90 at an angle of attack of 1°; variables are pressure distribution, wing chord grid points, total field points, and approximate computing time; seven figures and one table include numeric data.

78. Boppe, C. W.: *Computational Transonic Flow About Realistic Aircraft Configurations*. AIAA-78-104, Jan. 1978.

A numerical method has been developed to compute transonic flows about realistic wing-fuselage configurations. The finite difference scheme employs an improved small disturbance flow equation. A unique grid embedding technique, which was heretofore applied to airfoils and wings, has been extended to include the treatment of both body and wing-body shapes. The resulting high-density mesh is shown to be a valuable asset in resolving details of the three-dimensional flow. A mathematical modeling system is used to process arbitrary fuselage geometries for body boundary conditions. Correlations with experimental data for simple

isolated bodies, an isolated fuselage, and wing-fuselage combinations are included.

79. Boppe, Charles W.: *Towards Complete Configurations Using an Embedded Grid Approach*. NASA CR-3030, 1978.

A new approach to simulating transonic flow about transport configurations is briefly outlined. The embedded grid scheme of the method provides a high degree of computational resolution coupled with geometric flexibility for future applications to complex shapes. Calculations presented illustrate aspects of transonic transport design including fuselage design, determination of wing control surface deflection effectiveness, and wing design.

80. Baker, A. J.; Manhardt, P. D.; and Orzechowski, J. A.: *A Numerical Solution Algorithm for Prediction of Turbulent Aerodynamic Corner Flows*. AIAA-79-0073, Jan. 1979.

A numerical solution algorithm is established for prediction of subsonic turbulent three-dimensional flows in aerodynamic configuration juncture regions. In concert with a complete three-dimensional exterior potential flow solution, the developed parabolic algorithm yields prediction of the details of the corner region flow field. Turbulence closure is established using the complete Reynolds stress. Pressure coupling is accomplished using the concepts of complementary and particular solutions to a Poisson equation. Numerical results of three-dimensional turbulent flow in the juncture of two intersecting parabolic arc airfoils are presented.

81. Baker, A. J.; Manhardt, P. D.; and Orzechowski, J. A.: *Numerical Prediction of Turbulent Three-Dimensional Juncture Region Flow Using the Parabolic Navier-Stokes Equations*. NASA CR-159024, 1979.

A numerical solution algorithm is established for prediction of subsonic turbulent three-dimensional flows in aerodynamic configuration juncture regions. A turbulence closure model is established using the complete Reynolds stress. Pressure coupling is accomplished using the concepts of complementary and particular solutions to a Poisson equation. Specifications for data input juncture geometry modification are presented.

82. Boppe, C. W.; and Stern, M. A.: *Simulated Transonic Flows for Aircraft With Nacelles, Pylons, and Winglets*. AIAA-80-0130, Jan. 1980.

A computational method which simulates transonic flow about wing-fuselage configurations has been extended to include the treatment of multiple body and

nonplanar wing surfaces. The finite difference relaxation scheme is characterized by a modified small disturbance flow equation and multiple embedded grid system. Wing-body combinations with as many as four nacelles or pods, four pylons, and wing-tip-mounted winglets can be analyzed. A scheme for modeling inlet spillage and engine exhaust interference effects has been included. Computed results are correlated with experimental data for three transport configurations.

83. Boppe, C. W.; and Aidala, P. V.: *Complex Configuration Analysis at Transonic Speeds. Subsonic/Transonic Configuration Aerodynamics*, AGARD-CP-285. Sept. 1980, pp. 26-1-26-18.

Advanced performance requirements of new combat and transport aircraft together with design time constraints intensify the development and application of three-dimensional computational analyses. A computational method was developed for the specific purpose of providing an engineering analysis of complex aircraft configurations at transonic speeds. Particular attention is given to the recently incorporated wing viscous interaction and canard capabilities. The treatment of fuselage fairings, nacelles, and pylons is reviewed. The means for keeping computing resources at reasonable levels are identified. Three configurations were selected for correlations with experimental data. Taken together, the comparisons illustrate the full extent of current analysis capabilities. The configurations include (1) a wing-fuselage-canard fighter; (2) a transport with fuselage fairings, four nacelles and four pylons; and (3) a space vehicle which includes an external fuel tank and rocket boosters (transonic launch configuration).

84. Boppe, Charles W.: *Transonic Flow Field Analysis for Wing-Fuselage Configurations*. NASA CR-3243, 1980.

A computational method for simulating the aerodynamics of wing-fuselage configurations at transonic speeds is developed. The finite difference scheme is characterized by a multiple embedded mesh system coupled with a modified or extended small disturbance flow equation. This approach permits a high degree of computational resolution in addition to coordinate system flexibility for treating complex realistic aircraft shapes. To augment the analysis method and permit applications to a wide range of practical engineering design problems, an arbitrary fuselage geometry modeling system is incorporated as well as methodology for computing wing viscous effects. Configuration drag is broken down into its friction, wave, and lift-induced components. Typical computed results for isolated bodies, isolated wings, and wing-body combinations are presented. The results are correlated with experimental

data. A computer code which employs this methodology is described.

85. Ricci, R. J.; and Smyth, S. J.: The CADAM<sup>®</sup> System for Aircraft Structural Design. *SAE Transactions, Section 4, Volume 89*, Soc. Automot. Eng., Inc., c.1981, pp. 3704-3717. (Available as SAE Tech. Paper Ser. 801208.)

The use of interactive computer graphics for aircraft structural design, using the computer-graphics augmented design and manufacturing (CADAM) system in conjunction with surface definition and finite element model programs, is discussed. Beginning with a basic concept, configuration geometries are generated for analysis, preliminary design, loft, and production design organizations. Significant cost and time savings are demonstrated by use of the system in the design of a smaller horizontal tail for L-1011 airliner derivatives. In addition, the ability of the method described to perform more iterations in the development of a new product than was formerly possible, with great accuracy, is stressed. These productivity gains are crucial in light of the existing shortage of experienced designers.

86. McMahan, H.; Hubbartt, J.; and Kubendran, L.: *Mean Velocities and Reynolds Stresses in a Juncture Flow*. NASA CR-3605, 1982.

Values of three mean velocity components and six turbulence stresses measured in a juncture flow are presented and discussed. The juncture flow is generated by a constant thickness body having an elliptical leading edge, which is mounted perpendicular to a large flat plate along which a turbulent boundary layer is growing. The measurements were carried out at two streamwise stations in the juncture and were made using two single sensor hot-wire probes. The secondary flow in the juncture results in a considerable distortion in the mean velocity profiles. The secondary flow also transports turbulence in the juncture flow and has a large effect on the turbulence stresses. From visual inspection of the results, there is considerable evidence of similarity between the turbulent shear stresses and the mean flow strain rates. There is some evidence of similarity between the variations in the turbulent stress components.

87. Bauer, F.; Garabedian, P.; and McFadden, G.: *The NYU Inverse Swept Wing Code*. NASA CR-3662, 1983.

An inverse swept wing code is described that is based on the widely used transonic flow program FLO22. The new code incorporates a free boundary algorithm permitting the pressure distribution to be prescribed over a portion of the wing surface. A special

routine is included to calculate the wave drag, which can be minimized in its dependence on the pressure distribution. An alternate formulation of the boundary condition at infinity has been introduced to enhance the speed and accuracy of the code. A FORTRAN listing of the code and a listing of a sample run are presented. There is also a user's manual as well as glossaries of input and output parameters.

88. Gibson, S. G.: *System Maintenance Manual for MASTER: Modeling of Aerodynamic Surfaces by Three-Dimensional Explicit Representation*. NASA CR-172244, 1983.

A system of computer programs has been developed to model general three-dimensional surfaces. Surfaces are modeled as sets of parametric bicubic patches. There are also capabilities to transform coordinates, to compute mesh-surface intersection normals, and to format input data for a transonic potential flow analysis (NASA CR-3534). A graphical display of surface models and intersection normals is available. There are additional capabilities to regulate point spacing on input curves and to compute surface-surface intersection curves. Input and output data formats are described; detailed suggestions are given for user input. Instructions for execution are given, and examples are shown.

89. Gibson, S. G.: *User's Manual for MASTER: Modeling of Aerodynamic Surfaces by Three-Dimensional Explicit Representation*. NASA CR-166056, 1983.

A system of computer programs has been developed to model general three-dimensional surfaces. Surfaces are modeled as sets of parametric bicubic patches. There are also capabilities to transform coordinates, to compute mesh-surface intersection normals, and to format input data for a transonic potential flow analysis (NASA CR-3514). A graphical display of surface models and intersection normals is available. There are additional capabilities to regulate point spacing on input curves and to compute surface-surface intersection curves. Internal details of the implementation of this system are explained, and maintenance procedures are specified.

### Active Controls

For related documents, see entries 1, 8, 10, 14, 15, and the entries in the next three subsections.

90. Boeing Commercial Airplane Co.: *Integrated Energy Management Study*. NASA CR-158980, [1978].

The Integrated Energy Management (IEM) Study investigated the practicality and feasibility of a closed-loop energy management system for transport aircraft.

The study involved (1) instrumentation and collection of in-flight data for a United Airlines 727-200 flying 80 revenue flights throughout the United Airlines network, (2) analyses of the in-flight data to select representative city pairs and establish operational procedures employed in flying a reference flight profile, (3) simulation of the reference profile in a fast-time model to verify the model and establish performance values against which to measure IEM benefits, (4) development of IEM algorithms, and (5) assessment of the IEM concept.

91. Johnston, J. F.; and Urie, D. M.: Development and Flight Evaluation of Active Controls in the L-1011. *CTOL Transport Technology—1978*, NASA CP-2036, Part II, 1978, pp. 647-685.

Active controls in the Lockheed L-1011 for increased energy efficiency are discussed. Active wing load alleviation for extended span, increased aspect ratio, and active stability augmentation with a smaller tail for reduced drag and weight are among the topics considered. Flight tests of active wing load alleviation on the baseline aircraft and moving-base piloted simulation for developing criteria for stability augmentation are also described.

92. Urie, David M.: L-1011 Active Controls, Design Philosophy and Experience. *Stability and Control*, AGARD CP-260, May 1979, pp. 20-1-20-9.

Aircraft active controls can be defined as control effectors activated by sensors through computers without pilot commands. A certificated commercial transport airplane, the Lockheed L-1011, currently employs several highly sophisticated systems satisfying this definition. The experience gained through development flight testing, commercial flight operation, and flight simulation research on active control applications is presented with the intent of relating design philosophy and results.

93. Gangsaas, Dagfinn; and Ly, Uy-Loi: Application of a Modified Linear Quadratic Gaussian Design to Active Control of a Transport Airplane. AIAA-79-1746, Aug. 1979.

Methods for analysis and synthesis of multivariable controllers using time-domain optimal control theory are described. The applications to the design of flutter suppression and gust load alleviation control laws for an active control technology airplane at two flight conditions are demonstrated. Preliminary results show that these design procedures offer systematic and direct ways of deriving control laws that satisfy typical active control design requirements. However, the complexity of the synthesized filters will impose an excessive computational burden on flight computers. It is recommended that future work be directed toward deriving

reduced-order filters that retain most of the closed-loop performance of optimal control laws and yet can easily be implemented on flight computers.

94. Lockheed-California Co.: *Accelerated Development and Flight Evaluation of Active Controls Concepts for Subsonic Transport Aircraft, Volume I—Load Alleviation/Extended Span Development and Flight Test*. NASA CR-159097, 1979.

Active wing load alleviation to extend the wing span of an L-1011 by 5.8 percent, giving a 3-percent reduction in cruise drag is covered. The active wing load alleviation used symmetric motions of the outboard ailerons for maneuver load control (MLC) and elastic mode suppression (EMS), and motions of the stabilizer for gust load alleviations (GLA). Slow maneuvers verified the MLC, and open- and closed-loop flight frequency response tests verified the aircraft dynamic response to symmetric aileron and stabilizer drives as well as the active system performance. Flight tests in turbulence verified the effectiveness of the active controls in reducing gust-induced wing loads. It is concluded that active wing load alleviation and extended span is proven in the L-1011 and is ready for application to airline service; it is a very practical way to obtain the increased efficiency of a higher aspect-ratio wing with minimum structural impact.

95. Gangsaas, D.; Ly, U.; and Norman, D. C.: Practical Gust Load Alleviation and Flutter Suppression Control Laws Based on a LQG Methodology. AIAA-81-0021, Jan. 1981.

A modified linear quadratic Gaussian (LQG) synthesis procedure has been used to design low-order robust multiloop controllers for a flexible airplane. The introduction of properly constructed fictitious Gauss-Markov processes in the control loops allowed meeting classical frequency-domain stability criteria using the direct synthesis procedures of modern time-domain control theory. Model reduction was used to simplify the control laws to the point that they could be easily implemented on onboard flight computers. These control laws provided excellent gust load and flutter mode control with good stability margins and compared very favorably with other control laws synthesized by the classical root-locus technique.

96. Douglas Aircraft Co.: *Experimental Investigation of Elastic Mode Control on a Model of a Transport Aircraft*. NASA CR-3472, 1981.

A 4.5-percent-scale DC-10 derivative flexible model with active controls was fabricated, developed, and tested to investigate the ability to suppress flutter and reduce gust loads with actively controlled surfaces. The

model was analyzed and tested in both semispan and complete model configurations. Analytical methods were refined and control laws were developed and successfully tested on both versions of the model. A 15- to 25-percent increase in flutter speed due to the active system was demonstrated. The capability of an active controls system to significantly reduce wing bending moments due to turbulence was demonstrated. In general, good correlation was obtained between test and analytical predictions. Areas requiring further investigation and development were identified.

97. Rooney, R. H.; Chung, J. C.; and Shapiro, E. Y.: Modal Control of Relaxed Static Stability Aircraft. *A Collection of Technical Papers—AIAA Guidance and Control Conference*, Aug. 1982, pp. 173-176. (Available as AIAA-82-1524.)

A method is developed that assigns a selected portion of a closed-loop system eigenstructure in accordance with certain desirable criteria. The method is applied here to a relaxed static stability aircraft, the goal being to synthesize a control law that provides the unstable aircraft with handling qualities equal to or better than those of a comparable statically stable aircraft. It is shown that by using the target system eigenstructure, good flight characteristics are achieved by the unstable aircraft. It is also shown that improved characteristics can be obtained by assigning an orthogonal eigenvector structure.

98. Youssef, H. M.; and Davis, W. J.: Nonlinear Controller for the Pitch-Up Region. AIAA-83-0064, Jan. 1983.

An advanced pitch active controls system (PACS) was developed under the NASA Aircraft Energy Efficiency (ACEE) Program, using normal acceleration, pitch rate, and pitch attitude feedback signals to control the short period and phugoid motion. The feedback gains were scheduled as functions of stabilizer trim position and dynamic pressure. Two different approaches to the synthesis of a nonlinear controller are discussed using different sensor signals and shaping filters. One approach is based on adjusting the stabilizer trim position signal used in the feedback gain schedule as a function of Mach number and angle of attack. The other approach is a direct stabilizer command as a function of stabilizer position, Mach number, normal acceleration, and washed-out pitch rate. Simulation results in the time domain show the effectiveness of different designs and some practical aspects that should be considered.

*Pitch-augmented stability (PAS)*. For related documents, see entries 18, 19, 38-41, 43, and 45.

99. Sizlo, T. R.; Berg, R. A.; and Gilles, D. L.: *Development of a Low-Risk Augmentation System for an Energy-Efficient Transport Having Relaxed Static Stability*. NASA CR-159166, 1979.

This report describes the development of an augmentation system for a 230-passenger, twin-engine aircraft designed with relaxation of conventional longitudinal static stability. The design criteria are established and candidate augmentation system control laws and hardware architecture are formulated and evaluated with respect to reliability, flying qualities, and flight path tracking performance. The selected systems are shown to satisfy the interpreted regulatory safety and reliability requirements while maintaining the present DC-10 (study baseline) level of maintainability and reliability for the total flight control system. The impact of certification of the relaxed static stability augmentation concept is also estimated with regard to affected federal regulations, system validation plan, and typical development and installation costs.

100. Urie, D. M.; et al.: *Accelerated Development and Flight Evaluation of Active Controls Concepts for Subsonic Transport Aircraft, Volume II—Aft C.G. Simulation and Analysis*. NASA CR-159098, 1979.

Relaxed static stability and stability augmentation with active controls were investigated for subsonic transport aircraft. Analytical and simulator evaluations were done using a contemporary wide-body transport as a baseline. Criteria for augmentation system performance and unaugmented flying qualities were evaluated. Augmentation control laws were defined based on selected frequency response and time history criteria. Flying qualities evaluations were conducted by pilots using a moving-base simulator with a transport cab. Static margin and air turbulence intensity were varied in tests with and without augmentation. Suitability of a simple pitch control law was verified at zero static margin in cruise and landing flight tasks. Neutral stability was found to be marginally acceptable in heavy turbulence in both cruise and landing conditions.

101. Guinn, Wiley A.: *Development and Flight Evaluation of an Augmented Stability Active Controls Concept*. NASA CR-165951, 1982.

This report documents Task I for development and flight test of a limited authority pitch active control system (PACS) on a wide-body jet transport (L-1011) with a flying horizontal stabilizer. Two dual-channel digital computers and the associated software provide command signals to a dual-channel series servo which controls the stabilizer power actuators. Input sensor signals to the computer are pitch rate, column-trim position, and dynamic pressure. Control laws are given

for the PACS and the system architecture is defined. Discussions are given regarding piloted flight simulation and vehicle system simulation tests that are performed to verify control laws and system operation prior to installation on the aircraft. Modifications to the basic aircraft include installation of the PACS, addition of a c.g. management system to provide a c.g. range from 25 to 39 percent mac, and downrigging of the geared elevator to provide the required nosedown control authority for aft c.g. flight test conditions. Three pilots used the Cooper-Harper rating scale to judge flying qualities of the aircraft with PACS on and off. The handling qualities for cruise and high-speed flight conditions with the c.g. at 39 percent mac (+1 percent stability margin) and PACS operating were judged to be as good as the handling qualities with the c.g. at 25 percent (+15 percent stability margin) and PACS off.

**102.** Rising, J. J.; Davis, W. J.; and Grantham, W. D.: An Advanced Control System for a Next Generation Transport Aircraft. *A Collection of Technical Papers—AIAA Guidance and Control Conference*, Aug. 1983, pp. 195–209. (Available as AIAA-83-2194.)

The use of modern control theory to develop a high-authority stability and control system for the next generation transport aircraft is described with examples taken from work performed on an advanced pitch active controls system (PACS). The PACS was configured to have short-period and phugoid modes frequency and damping characteristics within the shaded S-plane areas, column-force gradients with set bounds and with constant slope, and a blended normal-acceleration/pitch rate time history response to a step command. Details of the control law, feedback loop, and modal control syntheses are explored, as are compensation for the feedback gain, the deletion of the velocity signal, and the feedforward compensation. Scheduling of the primary and secondary gains is discussed, together with control law mechanization, flying qualities analyses, and application to the L-1011 aircraft.

**103.** Guinn, Wiley A.; Willey, Craig S.; and Chong, Michael G.: *Extended Flight Evaluation of a Near-Term Pitch Active Controls System*. NASA CR-172266, 1983.

Fuel savings can be achieved by moving the center of gravity of an aircraft aft which reduces the static stability margin and consequently the trim drag. However, flying qualities of an aircraft with relaxed static stability can be significantly degraded. The flying qualities can be restored by using a pitch active controls system (PACS). This report documents the work accomplished during a follow-on program (see NASA CR-165951 (entry 101) for initial program report) to perform extended flight tests of a near-term PACS. The

program included flying qualities analyses, piloted flight simulation tests, aircraft preparation and flight tests to demonstrate that the near-term PACS provided good flying qualities within the linear static stability envelope to a negative 3-percent static stability margin.

**104.** Guinn, Wiley A.; Rising, Jerry J.; and Davis, Walt J.: *Development of an Advanced Pitch Active Control System for a Wide Body Jet Aircraft*. NASA CR-172277, 1984.

An advanced pitch active control system (PACS) control law was developed for a commercial wide-body transport (Lockheed L-1011) by using modern control theory. Validity of the control law was demonstrated by piloted flight simulation tests on the NASA Langley Visual/Motion Simulator. The PACS design objective was to develop a PACS that would provide, at negative 10-percent static stability margins, flying qualities that were equivalent to those of the baseline aircraft at a 15-percent static stability margin (which is normal for the L-1011). Also, the PACS was to compensate for high-Mach/high-g instabilities that degrade flying qualities during upset recoveries and maneuvers. The piloted flight simulation tests showed that the PACS met the design objectives. The simulation demonstrated good flying qualities to negative 20-percent static stability margins for hold, cruise, and high-speed flight conditions. Analysis and wind tunnel tests performed in other Lockheed programs indicate that the PACS could be used on an advanced transport configuration to provide a 4-percent fuel saving which results from reduced trim drag by flying at negative static stability margins.

#### *Integrated Application of Active Controls (IAAC).*

For related documents, see entries 10, 11, and 145.

**105.** Shomber, Henry A.: Application of Integrated Active Controls to Future Transports. AIAA-79-1654, Aug. 1979.

Active controls technology (ACT) potentially offers significant improvements in commercial transport performance and economics. Realization of these gains will only follow a believable determination of the specific potential benefits, and development and test of system elements to meet the reliability and availability necessary for commercial use. The paper briefly summarizes the Integrated Application of Active Controls (IAAC) Technology to Advanced Subsonic Transports Project. The IAAC Project is designed to assess the benefits of ACT applied to a specific commercial transport mission. The paper presents the very encouraging results available to date, and a projection of what may be possible with active controls.

106. Boeing Commercial Airplane Co.: *Integrated Application of Active Controls (IAAC) Technology to an Advanced Subsonic Transport Project—Initial ACT Configuration Design Study*.

A. *Final Report*. NASA CR-159249, [1979].

B. *Summary Report*. NASA CR-3304, 1980.

These reports document the Initial ACT Configuration Design Task of the Integrated Application of Active Controls (IAAC) Technology Project within the Energy Efficient Transport Program. A constrained application of active controls technology (ACT) resulted in significant improvements over the Conventional Baseline Configuration previously established (see NASA CR-159248, entry 107). The Initial ACT Configuration uses the same levels of technology, takeoff gross weight, payload, and design requirements or objectives as the Baseline Configuration, except for flying qualities, flutter, and ACT. The Baseline wing is moved forward 1.68 m. The configuration incorporates pitch-augmented stability (which enabled an approximately 10-percent aft shift in cruise center of gravity and a 45-percent reduction in horizontal tail size), lateral-directional augmented stability, an angle-of-attack limiter, wing load alleviation, and flutter-mode control. This results in a 930-kg reduction in airplane operating empty weight and a 3.6-percent improvement in cruise efficiency, yielding a 13-percent range increase. Adjusted to the 3590-km Baseline mission range, this amounts to a 6-percent block fuel reduction and a 15.7-percent higher incremental return on investment, using 1978 dollars and fuel cost. Results of the Initial ACT Task indicate that the IAAC Project should proceed to determine further benefits achievable through wing planform changes and advanced technology systems.

107. Boeing Commercial Airplane Co.: *Integrated Application of Active Controls (IAAC) Technology to an Advanced Subsonic Transport Project—Conventional Baseline Configuration Study, Final Report*. NASA CR-159248, 1980.

This report documents the first task of the Integrated Application of Active Controls (IAAC) Technology Project within the Energy Efficient Transport (EET) Program. A comprehensive data base was developed and assembled for a modern Mach 0.8 passenger airplane in the traffic segment where most fuel is used. The technology level of this configuration consists of conventional construction with advanced aluminum alloys and some graphite-epoxy for the secondary structure. Modern systems emphasize application of digital electronics and advanced displays. A substantial amount of design, test, and analysis data were taken from an early stage of the Boeing 767 Airplane Program. Refinements included more in-depth studies in

areas that will benefit from the application of active controls and of a supplementary wing flutter analysis and corresponding update. This data base will be used as a point of departure, during later activities on the IAAC Project, for development of additional configurations that use active controls technology (ACT) for reduced weight and improved aerodynamics. The technical characteristics of the future ACT configurations will be measured against the Baseline Configuration.

108. Brown, John D.; and Thomas, Charles J.: *Potential Benefits of Integrated Active Controls System for Current Technology Commercial Transports*. SAWE Paper No. 1432, Soc. Allied Weight Eng., Inc., May 1981.

This paper summarizes the definition of five current technology commercial transport airplanes with integrated active controls systems. Their potential performance and economic improvements relative to a Conventional Baseline Airplane are presented. Weight assessments of active controls functions, a summary of the wing structure detailed weight analysis, and center-of-gravity management (balance and loadability) data are also discussed.

109. Boeing Commercial Airplane Co.: *Integrated Application of Active Controls (IAAC) Technology to an Advanced Subsonic Transport Project—Current and Advanced ACT Control System Definition Study*.

A. *Volume I—Final Report, Volume II—Appendices*. NASA CR-165631, 1981.

B. *Summary Report*. NASA CR-3545, 1982.

These reports document the Current and Advanced Technology ACT Control System Definition Tasks of the Integrated Application of Active Controls (IAAC) Technology Project within the Energy Efficient Transport Program. The system definitions support the Initial ACT Configuration, wing planform study and Final ACT Configuration selection with data to validate the assessment of their energy efficiency. Study ground rules allowed the current technology system to use only technology elements fully demonstrated and available in 1980; the advanced technology system represents technology of the 1990's era. The systems mechanize six active control functions: pitch-augmented stability, angle-of-attack limiting, lateral-directional augmented stability, gust load alleviation, maneuver load control, and flutter-mode control. The redundant digital control systems defined meet all function requirements with required reliability and declining weight and cost as advanced technology is introduced. They indicate the advisability of demonstrating key system elements in laboratory and flight test.

110. Boeing Commercial Airplane Co.: *Integrated Application of Active Controls (IAAC) Technology to an Advanced Subsonic Transport Project—Wing Planform Study and Final Configuration Selection.*

A. *Final Report.* NASA CR-165630, 1981.

B. *Summary Report.* NASA CR-3468, 1981.

These reports document the Wing Planform Study Task and Final Configuration selection of the Integrated Application of Active Controls (IAAC) Technology Project within the Energy Efficient Transport Program. Application of active controls technology (ACT) in combination with increased wing span resulted in significant improvements over the Conventional Baseline Configuration previously established (entry 107). The configurations use the same levels of technology (except for ACT), takeoff gross weight, and payload as the Baseline Configuration. The Final ACT Configuration (Model 768-107) incorporates pitch-augmented stability (which enables an approximately 10-percent aft shift in cruise center of gravity and a 45-percent reduction in horizontal tail size), lateral-directional augmented stability, an angle-of-attack limiter, and wing load alleviation. Flutter-mode control was not beneficial for this configuration. These features led to an 890-kg (1960-lb) reduction in airplane takeoff gross weight and a 9.8-percent improvement in cruise lift/drag. At the Baseline mission range (3590 km (1938 nmi)), this amounts to a 10-percent block fuel reduction. Good takeoff performance at high-altitude airports on a hot day was also achieved. Results of this task strongly indicate that the IAAC Project should proceed with the Final ACT evaluation and begin the required control system development and testing.

111. Boeing Commercial Airplane Co.: *Integrated Application of Active Controls (IAAC) Technology to an Advanced Subsonic Transport Project. ACT/Control/Guidance System Study—Volumes I and II, Final Report.* NASA CR-165963, 1982.

This report documents the ACT/Control/Guidance System Task of the Integrated Application of Active Controls (IAAC) Technology Project within the NASA Energy Efficient Transport Program. The air traffic environment of navigation and air traffic control systems and procedures were extrapolated to the 1990's era for conclusions bearing on ACT airplane consequences of avionics system elements and operating procedures. A top-down approach to listing flight functions to be performed by systems and crew of an ACT-configured airplane of the 1990's, together with a determination of function criticalities to safety of flight, formed the basis of candidate integrated ACT/control/guidance system architectures.

In addition to the conventional control and navigation functions, the system mechanized five active control functions: pitch-augmented stability, angle-of-attack limiting, lateral-directional augmented stability, gust load alleviation, and maneuver load control. The scope and requirements of a program for simulating the integrated ACT avionics and flight deck system, with pilot in the loop, were defined in terms of simulation scenario, system and crew interface elements to be simulated, and the recommended mechanization. Particular attention was given to the requirement to evaluate relationships between system design and crew roles and procedures.

112. Boeing Commercial Airplane Co.: *Integrated Application of Active Controls (IAAC) Technology to an Advanced Subsonic Transport Project—Demonstration ACT System Definition, Final Report.* NASA CR-165920, 1982.

This report summarizes the Demonstration Active Controls Technology (ACT) System Definition Task of the Integrated Application of Active Controls (IAAC) Project within the NASA Energy Efficient Transport Program. It presents a 1985 ACT airplane and control system that mechanizes all flight control features that will produce important fuel savings.

The 1985 ACT airplane is the Final ACT Airplane with the addition of three-axis fly by wire. Thus it retains all the efficiency features of the full ACT system plus the weight and cost savings accruing from deletion of the mechanical control system. The control system implements the full IAAC spectrum of active controls except flutter-mode control, judged essentially nonbeneficial; and it incorporates new control surfaces called flaperons to make the most of wing load alleviation. This redundant electronic system is conservatively designed to preserve the extreme reliability required of crucial short-period pitch augmentation, which provides more than half of the fuel savings.

113. Boeing Commercial Airplane Co.: *Integrated Application of Active Controls (IAAC) Technology to an Advanced Subsonic Transport Project—Final ACT Configuration Evaluation.* NASA CR-3519, 1982.

This report summarizes the Final ACT Configuration Evaluation Task of the Integrated Application of Active Controls (IAAC) Technology Project within the Energy Efficient Transport Program. The Final ACT Configuration, through application of active controls technology (ACT) in combination with increased wing span, exhibits significant performance improvements over the Conventional Baseline Configuration. At the design range for these configurations, 3590 km (1938 nmi), the block fuel used is 10 percent less for



the Final ACT Configuration, with significant reductions in fuel usage at all operational ranges. Results of this improved fuel usage and additional system and airframe costs and complexity required to achieve it have been analyzed to determine its economic effects. For a 926-km (500-nmi) mission, the incremental return on investment (i.e., the return on the additional investment required for the Final ACT Configuration over the Baseline Configuration) is nearly 25 percent at 1980 fuel prices. For longer range missions or increased fuel prices, the return is greater.

This report also identifies the technical risks encountered in the Final ACT Configuration design and the research and development effort required to reduce these risks to levels acceptable for commercial airplane design.

**114.** Boeing Commercial Airplane Co.: *Integrated Application of Active Controls (IAAC) Technology to an Advanced Subsonic Transport Project—Test ACT System Description, Final Report.* NASA CR-172221, 1983.

This report documents the engineering and fabrication of the test ACT system, produced as the climax of the Integrated Application of Active Controls (IAAC) Project. The system incorporates pitch-augmented stability and wing load alleviation, plus full-authority fly-by-wire control of the elevators. The pitch-augmented stability is designed to have reliability sufficient to allow flight with neutral or negative inherent longitudinal stability. With reduction of the risk involved in the design of an active controls airplane as a goal, the system will be extensively tested in the Boeing Digital Avionics Flight Controls Laboratory and then test flown in a fly-by-wire mode on a Boeing 757-200 airplane.

**115.** Boeing Commercial Airplane Co.: *Integrated Application of Active Controls (IAAC) Technology to an Advanced Subsonic Transport Project—Test ACT System Validation.* NASA CR-172525, 1985.

This report documents the validation testing of the Test ACT System, and limited testing of a direct drive valve actuation concept, interfaced with the modified Test ACT System electronics. These tests were conducted under the final program element of the Integrated Application of Active Controls (IAAC) Technology to an Advanced Subsonic Transport Project, a part of the NASA/Boeing Energy Efficient Transport Technology Program. The Test ACT System as initially designed and built was a flight-worthy experimental implementation of selected active control functions (pitch-augmented stability and wing load alleviation) and a pitch axis fly-by-wire control system. It used

force-summed secondary servos to command the elevator power control units. The system was mounted in consoles so it could be readily installed and tested in the 757 flight test airplane. The validation testing was accomplished in the Boeing Digital Avionics Flight Controls Laboratory (DAFCL), where the system was connected through a work station interface to the laboratory simulation and instrumentation. Open-loop hardware and open-loop software tests were accomplished prior to the time the program was redirected to examine a direct-drive-valve actuation concept. In general the hardware was effective and all major functions worked well. The software tests showed that the software was well designed and implemented, and only minor problems were uncovered. No problems were identified that would have precluded flight test. However, several changes were identified that would be incorporated into a production form of the system. The system was modified to command elevator deflection through a direct-drive valve instead of the originally selected secondary servos, and was then tested in the laboratory. The results were encouraging, but several problem areas would require further work before the concepts, as examined in this test, would be ready for commercial application.

Due to the NASA decision to terminate funding for the IAAC Test ACT System work, this document constitutes the final technical report on the IAAC Project part of contract NAS1-15325.

### *Highly reliable flight controls*

**116.** Gerhart, Susan L.; and Yelowitz, Lawrence: Observations of Fallibility in Applications of Modern Programming Methodologies. *IEEE Trans. Software Eng.*, vol. SE2, no. 3, Sept., 1976, pp. 195-207.

Errors, inconsistencies, or confusing points are noted in a variety of published algorithms, many of which are being used as examples in formulating or teaching principles of such modern programming methodologies as formal specification, systematic construction, and correctness proving. Common properties of these points of contention are abstracted. These properties are then used to pinpoint possible causes of the errors and to formulate general guidelines which might help to avoid further errors. The common characteristic of mathematical rigor and reasoning in these examples is noted, leading to some discussion about fallibility in mathematics, and its relationship to fallibility in these programming methodologies. The overriding goal is to cast a more realistic perspective on the methodologies, particularly with respect to older methodologies, such as testing, and to provide constructive recommendations for their improvement.

117. Gerhart, Susan L.: *Development of a Methodology for Classifying Software Errors*. NASA CR-148212, 1976.

A mathematical formalization of the intuition behind classification of software errors is devised and then extended to a classification discipline: Every classification scheme should have an easily discernible mathematical structure and certain properties of the scheme should be decidable (although whether or not these properties hold is relative to the intended use of the scheme). Classification of errors then becomes an iterative process of generalization from actual errors to terms defining the errors together with adjustment of definitions according to the classification discipline. Alternatively, whenever possible, small-scale models may be built to give more substance to the definitions. The classification discipline and the difficulties of definition are illustrated by examples of classification schemes from the literature and a new study of observed errors in published papers of programming methodologies.

118. Dade, W. W.; Edwards, P. H.; Katt, G. T.; McClellan, K. L.; and Shomber, H. A.: *Flight Control Electronics Reliability/Maintenance Study*. NASA CR-145271, 1977.

Collection and analysis of data are reported that concern the reliability and maintenance experience of flight control system electronics currently in use on passenger-carrying jet aircraft. Two airline B-747 airplane fleets were analyzed to assess the component reliability, system functional reliability, and achieved availability of the CAT II configuration flight control system. Also assessed were the costs generated by this system in the categories of spare equipment, schedule, irregularity, and line and shop maintenance. The results indicate that although there is a marked difference in the geographic location and route pattern between the airlines studied, there is a close similarity in the reliability and the maintenance costs associated with the flight control electronics.

119. Hecht, H.; Sturm, W. A.; and Trattner, S.: *Reliability Measurement During Software Development*. NASA CR-145205, 1977.

During the development of data base software for a multisensor tracking system, reliability was measured. The failure ratio and failure rate were found to be consistent measures. Trend lines were established from these measurements that provided good visualization of the progress on the job as a whole as well as on individual modules. Over one-half of the observed failures were due to factors associated with the individual run submission rather than with the code proper. Possible application of these findings for line management,

project managers, functional management, and regulatory agencies is discussed. Steps for simplifying the measurement process and for use of these data in predicting operational software reliability are outlined.

120. Hecht, Herbert: *Measurement, Estimation, and Prediction of Software Reliability*. NASA CR-145135, 1977.

Quantitative indices of software reliability are defined, and application of three important indices is indicated: (1) reliability measurement, (2) reliability estimation, and (3) reliability prediction. State-of-the-art techniques for each of these procedures are presented together with considerations of data acquisition. Failure classifications and other documentation for comprehensive software reliability evaluation are described.

121. Advanced Program Div., Aerospace Corp.: *Fault-Tolerant Software Study*. NASA CR-145298, 1978.

Concepts for software to implement real time aircraft control systems on a centralized digital computer were discussed. A fault-tolerant software structure employing functionally redundant routines with concurrent error detection was proposed for critical control functions involving safety of flight and landing. A degraded recovery block concept was devised to allow collocation of critical and noncritical software modules within the same control structure. The additional computer resources required to implement the proposed software structure for a representative set of aircraft control functions were discussed. It was estimated that approximately 30 percent more memory space is required to implement the total set of control functions. A reliability model for the fault-tolerant software was described and parametric estimates of failure rate were made.

122. Maxwell, F. D.: *The Determination of Measures of Software Reliability*. NASA CR-158960, 1978.

Measurement of software reliability was carried out during the development of data base software for a multisensor tracking system. The failure ratio and failure rate were found to be consistent measures. Trend lines could be established from these measurements that provide good visualization of the progress on the job as a whole as well as on individual modules. Over one-half of the observed failures were due to factors associated with the individual run submission rather than with the code proper. Possible application of these findings for line management, project managers, functional management, and regulatory agencies is discussed. Steps for simplifying the measurement process and for use of

these data in predicting operational software reliability are outlined.

**123.** Meyer, John F.: *Models and Techniques for Evaluating the Effectiveness of Aircraft Computing Systems—Semiannual Status Report No. 3*. NASA CR-158992, 1978.

The development of system models that can provide a basis for the formulation and evaluation of aircraft computer system effectiveness, the formulation of quantitative measures of system effectiveness, and the development of analytic and simulation techniques for evaluating the effectiveness of a proposed or existing aircraft computer are described. Specific topics covered include system models; performability evaluation; capability and functional dependence; computation of trajectory set probabilities; and hierarchical modeling of an air transport mission.

**124.** Meyer, John F.: *Models and Techniques for Evaluating the Effectiveness of Aircraft Computing Systems—Semiannual Status Report No. 4*. NASA CR-158993, 1978.

Progress in the development of system models and techniques for the formulation and evaluation of aircraft computer system effectiveness is reported. Topics covered include analysis of functional dependence, a prototype software package, METAPHOR, developed to aid the evaluation of performability; and a comprehensive performability modeling and evaluation exercise involving the SIFT computer.

**125.** Miller, Douglas R.: *A Maintenance Model for K-Out-of-N Subsystems Aboard a Fleet of Advanced Commercial Aircraft*. NASA CR-145272, 1978.

Proposed highly reliable fault-tolerant reconfigurable digital control systems for a future generation of commercial aircraft consist of several  $k$ -out-of- $n$  subsystems. Each of these flight-critical subsystems will consist of  $n$  identical components,  $k$  of which must be functioning properly in order for the aircraft to be dispatched. Failed components are recoverable; they are repaired in a shop. Spares are inventoried at a main base where they may be substituted for failed components on planes during layovers. Penalties are assessed when failure of a  $k$ -out-of- $n$  subsystem causes a dispatch cancellation or delay. A maintenance model for a fleet of aircraft with such control systems is presented. The goals are to demonstrate economic feasibility and to optimize.

**126.** Nagel, Phyllis M.: *Modeling of a Latent Fault Detector in a Digital System*. NASA CR-145371, 1978.

Methods of modeling the detection time or latency period of a hardware fault in a digital system are proposed that explain how a computer detects faults in a computational mode. The objectives were to study how software reacts to a fault, to account for as many variables as possible affecting detection, and to forecast a given program's detecting ability prior to computation. A series of experiments was conducted on a small emulated microprocessor with fault injection capability. Results indicate that the detecting capability of a program largely depends on the instruction subset used during computation and the frequency of its use and has little direct dependence on such variables as fault mode, number set, degree of branching, and program length. A model is discussed which employs an analog with balls in an urn to explain the rate of which subsequent repetitions of an instruction or instruction set detect a given fault.

**127.** Smith, T. B.; Hopkins, A. L.; Taylor, W.; Ausrotas, R. A.; Lala, J. H.; Hanley, L. D.; and Martin, J. H.: *A Fault-Tolerant Multiprocessor Architecture for Aircraft—Volume I*. NASA CR-3010, 1978.

A fault-tolerant multiprocessor architecture is reported. This architecture, together with a comprehensive information system architecture, has important potential for future aircraft applications. A preliminary definition and assessment of a suitable multiprocessor architecture for such applications are developed.

**128.** Boeing Commercial Airplane Co.: *B-747 Primary Flight Control Systems Reliability and Maintenance Study*. NASA CR-159010, 1979.

The major operational characteristics of the 747 Primary Flight Control Systems (PFCS) are described. Results of reliability analyses for separate control functions are presented. The analysis makes use of a NASA computer program which calculates reliability of redundant systems. Costs for maintaining the 747 PFCS in airline service are assessed. The reliabilities and costs will provide a baseline for use in trade studies of future flight control system design.

**129.** Pease, M.; Shostak, R.; and Lamport, L.: Reaching Agreement in the Presence of Faults. *J. ACM*, vol. 27, no. 2, Apr. 1980, pp. 228-234.

The problem addressed here concerns a set of isolated processors, some unknown subset of which may be faulty, that communicate only by means of two-party messages. Each nonfaulty processor has a private value of information that must be communicated to each other nonfaulty processor. Nonfaulty processors always communicate honestly, whereas faulty processors may lie. The problem is to devise an algorithm

in which processors communicate their own values and relay values received from others that allows each non-faulty processor to infer a value for each other processor. The value inferred for a nonfaulty processor must be that processor's private value, and the value inferred for a faulty one must be consistent with the corresponding value inferred by each other nonfaulty processor.

It is shown that the problem is solvable for, and only for,  $n \geq 3m + 1$ , where  $m$  is the number of faulty processors and  $n$  is the total number. It is also shown that if faulty processors can refuse to pass on information but cannot falsely relay information, the problem is solvable for arbitrary  $n \geq m > 0$ . This weaker assumption can be approximated in practice using cryptographic methods.

**130.** Boeing Commercial Airplane Co.: *Cost and Benefits Design Optimization Model for Fault Tolerant Flight Control Systems*. NASA CR-159281, 1980.

Requirements and specifications for a method of optimizing the design of fault-tolerant flight control systems are provided. Algorithms that could be used for developing new and modifying existing computer programs are also provided, with recommendations for follow-on work.

**131.** Edwards, R. H.; and Enright, T. P.: *B-747 Flight Control System Maintenance and Reliability Data Base for Cost Effectiveness Tradeoff Studies*. NASA CR-159275, 1980.

Primary and automatic flight controls are combined for a total flight control reliability and maintenance cost data base using information from two previous reports and additional cost data gathered from a major airline. A comparison of the current B-747 flight control system effects on reliability and operating cost with that of a B-747 designed for an active control wing load alleviation system is provided.

**132.** Hitt, E. F.; Bridgman, M. S.; and Robinson, A. C.: *Comparative Analysis of Techniques for Evaluating the Effectiveness of Aircraft Computing Systems*. NASA CR-159358, 1981.

Performability analysis is a technique developed for evaluating the effectiveness of fault-tolerant computing systems in multiphase missions. Performability was evaluated for its accuracy, practical usefulness, and relative cost. The evaluation was performed by applying performability and the fault tree method to a set of sample problems ranging from simple to moderately complex. The problems involved as many as five outcomes, two to five mission phases, permanent faults, and some functional dependencies. Transient faults and software

errors were not considered. A different analyst was responsible for each technique. Significantly more time and effort were required to learn performability analysis than the fault tree method. Performability is inherently as accurate as fault tree analysis. For the sample problems, fault trees were more practical and less time consuming to apply, while performability required less ingenuity and was more checkable. Performability offers some advantages for evaluating very complex problems.

**133.** Hopkins, A. L.; Martin, J. H.; Brock, L. D.; Jansson, D. G.; Serben, S.; Smith, T. B.; and Hanley, L. D.: *System Data Communication Structures for Active-Control Transport Aircraft—Volume I*. NASA CR-165773, 1981.

Candidate data communication techniques are identified, including dedicated links, local buses, broadcast buses, multiplex buses, and mesh networks. The design methodology for mesh networks is then discussed, including network topology and node architecture. Several concepts of power distribution are reviewed, including current limiting and mesh networks for power. The technology issues of packaging, transmission media, and lightning are addressed, and, finally, the analysis tools developed to aid in the communication design process are described. There are special tools to analyze the reliability and connectivity of networks and more general reliability analysis tools for all types of systems.

**134.** Hopkins, A. L.; Martin, J. H.; Brock, L. D.; Jansson, D. G.; Serben, S.; Smith, T. B.; and Hanley, L. D.: *System Data Communication Structures for Active-Control Transport Aircraft—Volume II*. NASA CR-165774, 1981.

The application of communication structures to advanced transport aircraft is addressed. First, a set of avionic functional requirements is established, and a baseline set of avionics equipment is defined that will meet the requirements. Three alternative configurations for this equipment are then identified that represent the evolution toward more dispersed systems. Candidate communication structures are proposed for each system configuration, and these are compared using trade-off analyses; these analyses emphasize reliability but also address complexity. Multiplex buses are recognized as the likely near-term choice with mesh networks being desirable for advanced, highly dispersed systems.

**135.** McGough, John G.; and Swern, Fred L.: *Measurement of Fault Latency in a Digital Avionic Mini Processor*. NASA CR-3462, 1981.

The results of fault injection experiments utilizing a gate-level emulation of the central processor unit of the

Bendix BDX-930 digital computer are presented. The failure detection coverage of comparison-monitoring and a typical avionics CPU self-test program was determined. The specific tasks and experiments included (1) inject randomly selected gate-level and pin-level faults and emulate six software programs using comparison-monitoring to detect the faults; (2) based upon the derived empirical data, develop and validate a model of fault latency that will forecast a software program's detecting ability; (3) given a typical avionics self-test program, inject randomly selected faults at both the gate-level and pin-level and determine the proportion of faults detected; (4) determine why faults were undetected; (5) recommend how the emulation can be extended to multiprocessor systems such as SIFT; and (6) determine the proportion of faults detected by a uniprocessor BIT (built-in-test) irrespective of self-test.

**136.** Wensley, J. H.; Goldberg, J.; Green, M. W.; Kautz, W. H.; Levitt, K. N.; Mills, M. E.; Shostak, R. E.; Whiting-O'Keefe, P. M.; and Zeidler, H. M.: *Design Study of Software-Implemented Fault Tolerance (SIFT) Computer*. NASA CR-3011, 1982.

Software-implemented fault-tolerant (SIFT) computer design for commercial aviation is reported. A SIFT design concept is addressed. Alternate strategies for physical implementation are considered. Hardware and software design correctness is addressed. System modeling and effectiveness evaluation are considered from a fault-tolerant point of view.

**137.** Levitt, Karl N.; Schwartz, Richard; Hare, Dwight; Moore, J. S.; Melliar-Smith, P. Michael; Shostak, Robert E.; Boyer, Robert; Green, Milton; and Elliott, W. David: *Investigation, Development, and Evaluation of Performance Proving for Fault-Tolerant Computers*. NASA CR-166008, 1983.

Computers are being increasingly used as a critical component in nuclear reactors, aircraft, and other applications, where a failure can be life-threatening. Recent studies revealed that a centralized computer controlling a commercial aircraft should have a mean time to failure of at least 10 000 years. By the judicious application of hardware redundancy, such a reliability can be approached, assuming perfect software. The emerging technique of program verification gives promise of leading to vastly more reliable programs. Program verification is, at least conceptually, a very simple idea: by mathematical reasoning a program, for all input values, is shown to yield output values defined by an independently supplied formal specification. The state of the art in program verification is summarized by addressing the following issues: available techniques and on-line tools; the cost of verifying a system; possible sources of

unreliability in an alleged proof; and outstanding technical problems. A brief description is given of the SIFT (Software Implemented Fault Tolerance) computer and efforts to prove the correctness of its operating system.

**138.** McGough, John C.; and Swern, Fred L.: *Measurement of Fault Latency in a Digital Avionic Mini Processor—Part II*. NASA CR-3651, 1983.

Using a gate-level emulation of a typical avionics miniprocessor, fault injection experiments were performed to (1) determine the time to detect a fault by comparison monitoring, (2) forecast a program's ability to detect faults, and (3) validate the fault detection coverage of a typical self-test program. To estimate time to detect, six programs ranging in complexity from 6 to 147 instructions were emulated. Each program was executed repetitively in the presence of a single stuck-at-fault at a gate node or device pin. Detection was assumed to occur whenever the computed outputs differed from the corresponding outputs of the same program executed in a nonfaulted processor. Histograms of faults detected versus number of repetitions to detection were tabulated. Using a simple model of fault detection, which was based on an analog with the selection of balls in an urn, distributions of time to detect were computed and compared with those obtained empirically. A self-test program of 2000 executable instructions was designed expressly for the study. The only requirement imposed on the design was that it should achieve 95-percent coverage. The program was executed in the presence of a single stuck-at-fault at a gate node on device pin. The proportion of detected faults are tabulated. In all experiments faults were selected at random over gate nodes or device pins.

**139.** Goldberg, Jack; Kautz, William H.; Melliar-Smith, P. Michael; Green, Milton W.; Levitt, Karl N.; Schwartz, Richard L.; and Weinstock, Charles B.: *Development and Analysis of the Software Implemented Fault-Tolerance (SIFT) Computer*. NASA CR-172146, 1984.

SIFT (Software Implemented Fault Tolerance) is an experimental, fault-tolerant computer system designed to meet the extreme reliability requirements for safety-critical functions in advanced aircraft. Errors are masked by performing a majority voting operation over the results of identical computations, and faulty processors are removed from service by reassigning computations to the nonfaulty processors. This scheme has been implemented in a special architecture using a set of standard Bendix BDX-930 processors, augmented by a special asynchronous-broadcast communication interface that provides direct, processor-to-processor communication among all processors. Fault isolation is ac-

completed in hardware; all other fault-tolerance functions, together with scheduling and synchronization are implemented exclusively by executive system software. The system reliability is predicted by a Markov model. Mathematical consistency of the system software with respect to the reliability model has been partially verified, using recently developed tools for machine-aided proof of program correctness.

**140.** Hect, Herbert; and Hecht, Myron: *Fault-Tolerant Software for the FTMP*. NASA CR-166070, 1984.

The work reported on here provides protection against software failures in the task dispatcher of the fault-tolerant multiprocessor (FTMP), a particularly critical portion of the system software. Faults in other system modules and application programs can be handled by similar techniques but are not covered in this effort. Goals of the work reported on here are (1) to develop provisions in the software design that will detect and mitigate software failures in the dispatcher portion of the FTMP Executive and (2) to propose the implementation of specific software reliability measures in other parts of the system.

Beyond the specific support to the FTMP project, the work reported on here represents a considerable advance in the practical application of the recovery block methodology for fault-tolerant software design.

**141.** Smith, T. Basil, III; and Lala, Jaynarayan H.: *Development and Evaluation of a Fault-Tolerant Multiprocessor (FTMP) Computer*.

A. *Volume I—FTMP Principles of Operation*. NASA CR-166071, 1983.

B. *Volume II—FTMP Software*. NASA CR-166072, 1983.

C. *Volume III—FTMP Test and Evaluation*. NASA CR-166073, 1983.

D. *Volume IV—FTMP Executive Summary*. NASA CR-172286, 1984.

These reports describe the work done by the Charles Stark Draper Laboratory on the fault-tolerant multiprocessor (FTMP) project. The FTMP architecture is a high reliability computer concept modeled after a homogeneous multiprocessor architecture. Elements of the FTMP are operated in tight synchronism with one another and hardware fault-detection and fault-masking is provided which is transparent to the software. Operating system design and user software design is thus greatly simplified. Performance of the FTMP is also comparable to that of a simplex equivalent due to the efficiency of fault-handling hardware.

The FTMP project constructed an engineering module of the FTMP, programmed the machine and extensively tested the architecture through fault injection and other stress testing. This testing confirmed the soundness of the FTMP concepts.

### Handling Qualities

For related documents, see entries 14, 15, 91, 97, and 100-104.

**142.** Urie, D. M.: *Piloted Flight Simulation for Active Control Design Development*. AIAA-78-1553, Aug. 1978.

This paper reviews experience with piloted flight simulation in current transport development citing the L-1011 with SAS and direct lift control. Recent simulation studies of a relaxed static stability version of the L-1011 are discussed, as are tests using the vehicle systems simulator with pilot in the loop to verify handling qualities effects of active load alleviation. The role of flight simulator data in determining augmentation system reliability criteria is explored. Continued utility of piloted simulation for predicting certificability of flying qualities which depend on subjective evaluation is considered. Limitations of current equipment for future needs are discussed along with recommendations for simulator planning.

**143.** Rising, J. J.: *Development and Flight Test Evaluation of a Pitch Stability Augmentation System for a Relaxed Stability L-1011*. AIAA-82-1297, Aug. 1982.

The L-1011 has been flight tested to demonstrate the relaxed static stability concept as a means of obtaining significant drag benefits to achieve a more energy efficient transport. Satisfactory handling qualities were maintained using a horizontal tail designed with stability and control augmentation to allow operation of the L-1011 at centers of gravity close to the neutral point. Prior to flight test, a motion base visual flight simulator program was performed to optimize the augmentation system. The system was successfully demonstrated in a test program totaling 48 actual flight hours.

**144.** Levison, William H.; and Rickard, William W.: *Analytical and Simulator Study of Advanced Transport Handling Qualities*. NASA CR-3572, 1982.

An analytic methodology, based on the optimal-control pilot model, is demonstrated for assessing longitudinal-axis handling qualities of transport aircraft in final approach. Calibration of the methodology is largely in terms of closed-loop performance requirements, rather than specific vehicle response characteristics, and is based on a combination of published criteria,

pilot preferences, physical limitations, and engineering judgment.

Six longitudinal-axis approach configurations were studied covering a range of handling qualities problems, including the presence of flexible aircraft modes. The analytical procedure was used to obtain predictions of (a) Cooper-Harper ratings, (b) a scalar quadratic performance index, and (c) rms excursions of important system variables. A subsequent manned simulation study yielded objective and subjective performance measures that varied across vehicle configurations in the manner predicted by model analysis. In particular, flexible modes for the specific configurations explored in this simulation study were correctly predicted to have no significant effect on handling qualities.

**145.** Boeing Commercial Airplane Co.: *Integrated Application of Active Controls (IAAC) Technology to an Advanced Subsonic Transport Project—Longitudinal Handling Qualities Study of a Relaxed-Stability Airplane*. NASA CR-3660, 1983.

This report describes the results of a piloted simulation study of longitudinal handling qualities of an airplane with relaxed static stability. This task was performed under the Integrated Application of Active Controls (IAAC) Technology Project within the NASA Energy Efficient Transport Program. A representative medium-range transport airplane, the Boeing Model 757, was simulated. Evaluations were made of the unaugmented airplane and of the airplane with an essential pitch-augmented stability (PAS) system and with a primary PAS system at various center-of-gravity (c.g.) conditions. Level 2 pilot ratings (per MIL 8785C) were attained with c.g. locations aft to about 57 percent mean aerodynamic chord (mac) or 6 percent aft of the neutral point for unaugmented landing approach. For Mach 0.80, the unaugmented airplane model provided handling qualities close to or within the Level 1 boundary at all c.g. locations for both essential and primary PAS. Analyses of the test conditions when compared with existing handling qualities criteria based on unaugmented results are compared to those reported by both the Douglas Aircraft Company and the Lockheed-California Company from simulation investigations of transport configurations with roughly similar dimensional and mass characteristics.

### Interdisciplinary Technology Applications

**146.** Morrison, R. A.: *Design for Quick Reaction Aircraft Modification*. AIAA-80-1887, Aug. 1980.

The paper describes the techniques and shortcuts used to reduce engineering time for the preparation of aircraft prototype or modification drawings. The techniques include Computer Graphics Augmented Design

and Manufacturing (CADAM), nondimensional EMD drawings, line-following routers, computer-assisted loft plots, and the tailoring of existing designs to a modified design. Combining of these methods results in one-of-a-kind assemblies rapidly produced with a significant reduction in the number of drawings without sacrificing quality. Examples of recent programs for an experimental L-1011 aircraft tail assembly and for test installations for P-3 ASW aircraft were given.

**147.** Hays, A. P.; Beck, W. E.; Marita, W. H.; Penrose, B. J.; Skarshaug, R. E.; and Wainfan, B. S.: *Integrated Technology Wing Design Study*. NASA CR-3586, 1982.

This report describes a study to determine the technology development costs and associated benefits of applying advanced technology associated with the design of a new wing for a new or derivative trijet with a capacity for 350 passengers and maximum range of 8519 km (4600 nmi) entering service in 1990. The areas of technology are: (1) airfoil technology, (2) planform parameters, (3) high lift, (4) pitch active control system, (5) all-electric systems, (6) energy efficient engine propulsion, (7) airframe/propulsion integration, (8) graphite/epoxy composites, (9) advanced aluminum alloys, (10) titanium alloys, and (11) silicon carbide/aluminum composites. These technologies were applied to the reference aircraft configuration both individually and concurrently; payoffs were determined in terms of block fuel reductions and net value of technology. The technologies were then ranked in terms of the ratio of net value of technology (NVT) to technology development costs.

For a fleet of 400 aircraft, the application of all advanced technologies yields an NVT of \$72 billion (in 1980 dollars), for a total technology development cost of \$639 million. Reduction in block fuel is 40 percent for the "all advanced" configuration. Technology development in airfoil and planform offers the largest benefit in NVT per unit technology development cost, yielding \$17 billion increase in NVT (achieved with 11.3 percent reduction in block fuel) for \$28 million technology development cost. However, energy efficient engine propulsion technology with airframe/propulsion integration gives the greatest single benefit in NVT of \$19 billion, but at a technology development cost of \$243 million.

1. Report No. NASA RP-1135	2. Government Accession No.	3. Recipient's Catalog No.	
4. Title and Subtitle Energy Efficient Transport Technology—Program Summary and Bibliography		5. Report Date September 1985	
		6. Performing Organization Code 534-02-13-01	
7. Author(s) David B. Middleton, Dennis W. Bartlett, and Ray V. Hood		8. Performing Organization Report No. L-15921	
		10. Work Unit No.	
9. Performing Organization Name and Address NASA Langley Research Center Hampton, VA 23665		11. Contract or Grant No.	
		13. Type of Report and Period Covered Reference Publication	
12. Sponsoring Agency Name and Address National Aeronautics and Space Administration Washington, DC 20546		14. Sponsoring Agency Code	
		15. Supplementary Notes	
16. Abstract The Energy Efficient Transport (EET) Program began in 1976 as an element of the NASA Aircraft Energy Efficiency (ACEE) Program. This report describes the EET Program and summarizes the results of various applications of advanced aerodynamics and active controls technology (ACT) to future subsonic transport aircraft. A comprehensive listing of the documents (with their abstracts) published as a result of the EET Program is included. Advanced aerodynamics research areas included high-aspect-ratio supercritical wings, winglets, advanced high-lift devices, natural laminar flow airfoils, hybrid laminar flow control, nacelle aerodynamic and inertial loads, propulsion/airframe integration (e.g., long-duct nacelles), and wing and empennage surface coatings. In-depth analytical/trade studies, numerous wind tunnel tests, and several flight tests were conducted. Improved computational methodology was also developed. The active control functions considered were maneuver load control, gust load alleviation, flutter mode control, angle-of-attack limiting, and pitch-augmented stability. Current and advanced active control laws were synthesized and alternative control-system architectures were developed and analyzed. Integrated application and fly-by-wire implementation of the active control functions were design requirements in one major subprogram. Additional EET research included interdisciplinary technology applications, integrated energy management, handling qualities investigations, reliability calculations, and economic evaluations related to fuel savings and cost of ownership of the selected improvements.			
17. Key Words (Suggested by Authors(s)) Energy Efficient Transport (EET) Supercritical wing Winglets Nacelles Aircraft surface coatings Active controls technology (ACT) Pitch-augmented stability Wing load alleviation Fault-tolerant controls Aircraft handling qualities		18. Distribution Statement Unclassified—Unlimited  Subject Category 05	
19. Security Classif.(of this report) Unclassified	20. Security Classif.(of this page) Unclassified	21. No. of Pages 54	22. Price A04



National Aeronautics and  
Space Administration

Washington, D.C.  
20546

Official Business

Penalty for Private Use, \$300

**BULK RATE**  
**POSTAGE & FEES PAID**  
NASA Washington, DC  
Permit No. G-27

**NASA**

**POSTMASTER: If Undeliverable (Section 158  
Postal Manual) Do Not Return**

---