

**NASA
Technical
Paper
2487**

June 1985

NASA-TP-2487 19850025432

A Formulation and Analysis of Combat Games

Michael Heymann,
Mark D. Ardema, and
Narayanaswami Rajan

LIBRARY COPY

JUN 11 1985

LANGLEY RESEARCH CENTER
LIBRARY, NASA
HAMPTON, VIRGINIA

NASA



**NASA
Technical
Paper
2487**

1985

A Formulation and Analysis of Combat Games

Michael Heymann

*Technion-Israel Institute of Technology
Haifa, Israel*

Mark D. Ardema

*Ames Research Center
Moffett Field, California*

Narayanaswami Rajan

*Stanford University
Stanford, California*

NASA

National Aeronautics
and Space Administration

Scientific and Technical
Information Branch

TABLE OF CONTENTS

	Page
SUMMARY	1
1. INTRODUCTION.....	2
2. QUALITATIVE FEATURES OF COMBAT GAMES.....	4
3. FORMULATION OF COMBAT GAMES.....	7
4. FORMULATION OF δ -COMBAT GAMES.....	10
5. EXAMPLE OF A COMBAT GAME: THE TURRET GAME.....	13
Formulation.....	13
Linear Control Constraint.....	17
Circular Control Constraint.....	27
6. DISCUSSION.....	34
REFERENCES.....	39

A FORMULATION AND ANALYSIS OF COMBAT GAMES

Michael Heymann,* Mark D. Ardema, and Narayanaswami Rajan†

Ames Research Center

SUMMARY

Most investigations which use the theory of differential games to analyze combat problems have focused on deterministic, two-person, zero-sum, perfect-information pursuit-evasion games. This framework is quite suitable when the pursuer-evader roles are well defined by the nature of the problem and the evader has no offensive capability with which to threaten the pursuer to affect the outcome. The formulation is, however, inadequate to model combat between two (or more) opponents when both (or all) have offensive capabilities and objectives. An obvious example of such a situation is air-to-air combat. The few attempts to analyze this more general combat problem have used either concepts of role-determination or, more recently, that of a two-target differential game. Neither of these approaches, however, has led to a complete and consistent conceptual definition and corresponding mathematical theory of combat games. It is our purpose in this paper to formulate and illustrate such a theory.

We begin with a discussion of the qualitative features of combat games between two aggressive opponents; this discussion indicates the rich variety of behavior present in such games and makes clear the inadequacy of the pursuit-evasion assumption, with or without role determination, for modeling combat. We then propose a mathematical formulation of deterministic combat games between two opponents with offensive capabilities and offensive objectives. Resolution of the combat essentially involves solving two differential games with state constraints. Depending on the game dynamics and parameters, the combat can terminate in one of four ways: (1) the first player wins, (2) the second player wins, (3) a draw (neither wins), or (4) joint capture. In the first two cases, the optimal strategies of the two players are determined from suitable zero-sum games; whereas, in the latter two cases, the relevant game is nonzero-sum. Next, to avoid certain technical difficulties, the concept of a δ -combat game is introduced.

To illustrate the definition, formulation, and solution of combat games, an example, called the turret game, is analyzed in detail. This game may be thought of as a highly simplified model of air combat, yet it is sufficiently complex to

*Senior NRC Associate on sabbatical leave from Technion-Israel Institute of Technology, Haifa, Israel.

†Research Associate, Aeronautics and Astronautics Department, Stanford University, Stanford California.

exhibit a rich variety of combat behavior, much of which is not found in pure pursuit-evasion games.

1. INTRODUCTION

By a game of combat we intuitively refer to an encounter between two hostile adversaries, or players, each of whom wishes to destroy or capture the other, while, if possible, ensuring his own survival. A player who succeeds in capturing his opponent is said to win the game; if he can win, he will try to win with as little cost to himself as possible. If he is unable to do so, he will try to make his opponent's win as difficult or as costly as possible.

A conspicuous example, and one of the main incentives for investigating games of combat, is the aerial combat problem in which there is a duel between two (or even more) maneuvering aircraft. Various situations can be visualized; for example, a missile in pursuit of a plane, a fighter in pursuit of a bomber, a duel between two fighter aircraft.

In the simplest manifestation of a combat game, one of the players has no offensive capabilities so that he can never win in the above sense. Thus, the offensive player becomes the pursuer, and the inoffensive opponent becomes the evader. The resultant pursuit-evasion problem becomes what is sometimes called a game of survival (see e.g., ref. 1). The evader attempts to avoid capture or, if this is not possible, to maximize the pursuer's cost of attaining his goal; the pursuer endeavors to capture, and at minimum cost. The special (but important) case in which the cost functional is the time to capture, has sometimes been referred to as a game of pursuit-evasion (ref. 1).

The early studies of combat problems focused almost entirely on the above-mentioned framework in which the two players have the clearly defined (and opposing) roles of pursuer and evader, or minimizer and maximizer. Immediate applications of those studies are in such problems as missile versus aircraft or fighter versus bomber.

The generally accepted mathematical framework for formulating and solving pursuit-evasion problems is the theory of differential games according to Isaacs (ref. 2). Specifically, the game consists of a dynamical system whose state transition is governed by a set of n ordinary differential equations

$$\frac{dx}{dt} = f(t, x, u, v) , \quad (1)$$

where $x = x(t) \in \mathcal{R}^n$ is the state, $u = u(t) \in U \subset \mathcal{R}^m$ and $v = v(t) \in V \subset \mathcal{R}^p$ are the two players' controls, and $x(t_0) = x_0$ is the initial state. Associated with the game is a cost functional

$$J(u, v, x_0, t_0) = g[x(\bar{t}), \bar{t}] + \int_{t_0}^{\bar{t}} h[t, x(t), u(t), v(t)] dt , \quad (2)$$

where $\bar{t} (< \infty)$ is a free or fixed termination time. Typically, player u , the pursuer, attempts to minimize the cost J , whereas v , the evader, tries to maximize it. (Throughout the paper we do not make a notational distinction between the players and their controls, the meaning being clear from the context.) Various additional assumptions and constraints can be imposed on the problem to suit specific requirements.

In games of survival and of pursuit-evasion, the termination time is free and is determined by a capture condition; that is, a state constraint that is imposed on the problem as follows:

$$x(t) \notin \mathcal{F} \subset \mathcal{R}^n \quad \forall \quad t_0 \leq t < \bar{t} \quad (3)$$

and

$$x(\bar{t}) \in \mathcal{F} . \quad (4)$$

Here \mathcal{F} is the target or capture set and \bar{t} , defined through equations (3) and (4), is the capture time. The game of pursuit-evasion is thus the special case of the above framework in which $g = 0$ and $h = 1$, with the cost being the time to capture, $(\bar{t} - t_0)$. It is then natural to refer to the minimizing player u as the pursuer and to the maximizing player v as the evader.

Much research has been done on games of survival and games of pursuit-evasion within the general framework of differential game theory (see, e.g., refs. 1, 3-5). The early use of differential games in the modeling and analysis of aerial combat problems is reviewed in reference 6; a more recent review may be found in chapter 8 of reference 7. Although highly idealized, widely investigated models for pursuit-evasion analysis are the homicidal chauffeur game (refs. 2,8,9), and its generalization, the game of two cars. The latter was used as a model for aerial combat analysis in a variety of studies; see, for example, references 10-15 as well as the general survey article, reference 16. More recently, various generalizations of the game of two cars were used for analysis of aerial pursuit-evasion to accommodate variable speed and other aircraft capabilities (refs. 17-20). Also, special techniques were developed and examined to facilitate computation and to alleviate some of the difficulties associated with high dimensionality.

It was realized even in the early stages (ref. 6), however, that the pursuer-evader model is inadequate for a situation such as fighter versus fighter combat, in which there is no justification for an arbitrary a priori role assignment of pursuer and evader. This difficulty led to much confusion in efforts to reconcile the differential game methodology with intuition, based on the perceived experiences in actual combat situations. For example, it was stated in reference 6 that a multiple criterion may be required to formulate these aerial combat encounters correctly and that role reversals during a given encounter typically occur. In other studies, the idea was promoted that the central issue is that of role determination (refs. 7,13,21); that is, deciding which of the two players should assume the role of pursuer and which that of evader. While various approaches to the role

determination problem were proposed, it was generally believed that the winning player should always assume the role of pursuer while his opponent should assume that of evader.

Realizing that the existing approaches for determining the potential winner of a combat game were unsatisfactory, Getz and Pachter (refs. 22 and 23) adopted the concept of a two target game that was introduced earlier to the differential game literature by Blaquiere et al. (ref. 24) and Getz and Leitmann (ref. 25). In this setting, each player has a target set and attempts to drive the state into his target set without being first driven to the target set of his opponent. A further recent study that combines the role assignment point of view with the two-target idea has been reported in reference 26.

The work of Getz and Pachter, just as in most past studies of pursuit-evasion differential games, has been confined to the problem of capturability; that is, to the "game of kind" (in Isaac's terminology). The approach in such studies has been based on Isaac's technique of investigating certain semipermeable surfaces to determine barriers and other singular surfaces (ref. 2). This approach has contributed a great deal to the understanding of differential games; however, it has two serious limitations for application to combat problems. First, although a barrier analysis is plausible in very low dimensional problems, it becomes rapidly infeasible as the dimensionality increases, especially in the two-target case where added complexity arises. Indeed, Getz and Pachter made some major simplifications in their target-set geometries to overcome essential difficulties with dimensionality and render the analysis tractable in their investigations of the two-target homicidal chauffeur game (ref. 22) and the two-target game of two cars (ref. 23). The second limitation of barrier analysis is that it does not address the fundamental problem of determination of strategies; in fact, the player's actual optimal (or, at least, winning) strategies in combat situations remain obscure and unexplored.

In the present paper, we formulate and examine the combat problem for an arbitrary dynamical system from a strategy-analysis point of view.

2. QUALITATIVE FEATURES OF COMBAT GAMES

In an ordinary pursuit-evasion problem, the termination of the game (i.e., capture) is determined, as we have seen earlier, by the capture condition specified by equations (3) and (4) (which can also be stated in terms of equality or inequality constraints). The capturability issue constitutes the "game of kind" (ref. 2), and for a given initial state the problem is whether the pursuer can actually force capture or termination. The question of strategy (that is, how to accomplish capture when possible or how to prevent or delay it) constitutes the game of degree (ref. 2).

In the two-target combat model with targets, say, \mathcal{T}_u and \mathcal{T}_v , the termination condition is

$$x(t) \notin \mathcal{F} = \mathcal{F}_u \cup \mathcal{F}_v \quad \forall \quad t_0 \leq t < \bar{t}, \quad (5)$$

and

$$x(\bar{t}) \in \mathcal{F}, \quad (6)$$

where \mathcal{F}_u is the target associated with player u , and \mathcal{F}_v is the target associated with v . If $x(\bar{t}) \in \mathcal{F}_u$ but $x(t) \notin \mathcal{F}_v$ for all $t_0 \leq t \leq \bar{t}$, we say that player u wins the game; whereas, if $x(\bar{t}) \in \mathcal{F}_v$ and $x(t) \notin \mathcal{F}_u$ for $t_0 \leq t \leq \bar{t}$, we say that v wins. If $\mathcal{F}_u \cap \mathcal{F}_v \neq \phi$ and

$$x(\bar{t}) \in \mathcal{F}_u \cap \mathcal{F}_v, \quad (7)$$

we say that the game ends in joint capture. Finally, if $T^*(>t_0)$ is the maximum allowable termination time of the game, and if $x(t) \notin \mathcal{F}$ for all $t_0 \leq t \leq T^*$, we say that the game ends in a tie or draw.

In the pursuit-evasion game, the pursuing player wishes to lead the game to termination and, if he can, do so as quickly as possible. The evading player attempts to prevent termination or to delay it if prevention is impossible. In contrast, in the two-target problem the players' objectives are more complicated. In principle, both want to terminate the game but in different parts of \mathcal{F} . Player u wants it to terminate in $\mathcal{F}/\mathcal{F}_v$ (i.e., in \mathcal{F} excluding \mathcal{F}_v), and player v wants it to terminate in $\mathcal{F}/\mathcal{F}_u$.

To see how these conflicting objectives affect the players' strategies and to gain some insight into the actual situation, let us examine, qualitatively, a number of possible cases. Suppose that the capability of each player to evade his opponent's target is independent of, and decoupled from, his capability to pursue his opponent. (Air combat between two aircraft with actively guided air-to-air missiles is an example.) Each player would then play two simultaneous and independent pursuit-evasion games: one is an offensive game in which he would try to capture his opponent, the other a defensive game in which he would try to evade his opponent's weapons. The pursuit-evasion game that terminates first would determine the winner.

Suppose now that with each of the above mentioned pursuit-evasion games we associate a cost functional

$$J_i = g_i[x(\bar{t}_i), \bar{t}_i] + \int_{t_0}^{\bar{t}_i} h_i[t, x(t), u(t), v(t)] dt \quad i = u, v,$$

where \bar{t}_i is the termination time of game i . In game u , player u wishes to minimize, and player v wishes to maximize J_u ; in game v , player v is the minimizer and u the maximizer. Suppose that, if the competition between the two games is ignored, it develops that \bar{t}_u is greater than \bar{t}_v as optimal termination times. By this optimality criterion it would be concluded, quite possibly erroneously, that player v is the winner of the combat. Thus, even in this elementary

example, we are forced to add a constraint to each of the two games to account for the existence of the other, that is, for $i = u, v$, $x(t) \notin \mathcal{T}/\mathcal{G}_i$ for all $t_0 \leq t < \bar{t}_i$ (where \mathcal{T}_i denotes the target set of the game i). This constraint introduces a coupling between the two competing games that affects the players' strategies. A particularly interesting and important cost criterion is obtained when $g_i = 0$ and $h_i = 1$, $i = u, v$; that is, when both games assume a time-optimality criterion. Let $J_i^* = \bar{t}_i$, $i = u, v$ be the optimal times obtained in the two pursuit games where, in each game, the pursuer is the minimizer and the evader is the maximizer. Clearly, if $\bar{t}_u < \bar{t}_v$ then in game v the constraint $x(t) \notin \mathcal{T}/\mathcal{G}_v$ for all $t_0 \leq t < \bar{t}_v$ is violated and the constrained game v has no feasible solutions. Obviously u is the winning player.

In the more general case, the players cannot perform their evasive maneuvers, that is, they cannot stay out of range of their opponents' weapon envelopes (capture sets), independently of their offensive maneuvers to capture the opponent. Indeed, typically, there is a trade-off between the two objectives of survival and capture of the opponent, and the players have to play their strategies accordingly.

To illustrate the situations that might occur, consider two vehicles maneuvering in a horizontal plane (fig. 1). The arrows describe the vehicles' instantaneous headings, the cones the instantaneous envelopes of their weapons (fixed with respect to their headings) and the vertices of the cones are their instantaneous positions. We assume the typical situation that each player's maximum turn rate and speed are mutually dependent; specifically, the faster they move the slower they are able to turn, and conversely.

Suppose that player v initially is in a vulnerable position (see fig. 1) such that by a slight turn of player u , v might enter u 's weapon envelope, and

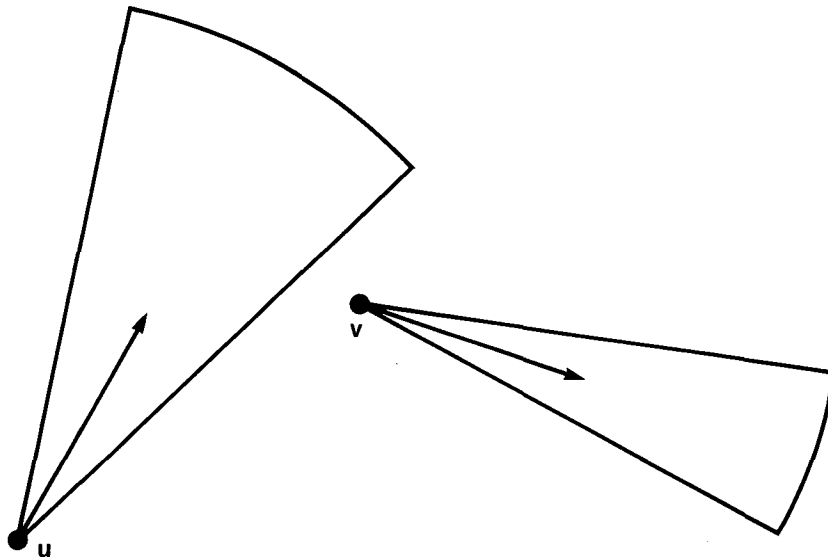

Figure 1.- Maneuvering vehicles.

further suppose that v is more maneuverable in terms of turn rate and speed than u . If v adopts a pure evasive maneuver and u pursues, two outcomes are possible: either v gets captured quickly or he evades successfully. If he can avoid capture initially, then in due time presumably he can capture u by virtue of his superior maneuverability. In the other case, even though v cannot avoid initial capture by u if he adopts pure (inoffensive) evasion, he may still be able to win the game by performing the offensive maneuver of turning his own target at u , thereby capturing u before u captures him. More generally, v may have to perform a composite (offensive-defensive) maneuver, wherein he turns his target at u while moving away from u 's target just enough to avoid being captured himself. Thus, player v might be able to win the game by a composite strategy even though he would lose it by playing pure evasion.

It is also of interest to examine the optimal play of player u under the assumption that v can win with an optimal composite strategy. In spite of his eventual capture, u should adopt an offensive behavior because when u turns his weapon at v , v 's offensive move is slowed down in order to survive u 's threat. At least, thereby, u 's capture is delayed. In this situation, roles of pursuer and evader cannot usefully be assigned to the two players.

Thus it is easy to understand that, in general, analysis of pure pursuit-evasion problems, with or without role-determination analyses, reveals little, if any, information about the possible outcomes and optimal strategies of a combat game. In fact, it may be expected that misleading conclusions frequently will be drawn. It is clear that a new and fundamentally different approach to the problem is required.

3. FORMULATION OF COMBAT GAMES

Consider a system described by a set of n ordinary differential equations,

$$\frac{dx}{dt} = f(t, x, u, v), \quad (8)$$

with initial time t_0 and initial state $x(t_0) = x_0$. The controls of the two players are measurable functions taking values in compact subsets $U \subset \mathcal{R}^m$ and $V \subset \mathcal{R}^p$, respectively.

Associated with the combat problem are two subsets $\bar{\mathcal{T}}_u$ and $\bar{\mathcal{T}}_v$ in \mathcal{R}^{n+1} , the (extended) targets or (extended) capture sets of the players. We will assume that $\bar{\mathcal{T}}_u$ and $\bar{\mathcal{T}}_v$ are the closures of some open subsets in \mathcal{R}^{n+1} and that there exists a time $T^* > t_0$ such that for all $x \in \mathcal{R}^n$ and all $t \geq T^*$, $(t, x) \in \bar{\mathcal{T}}_u \cap \bar{\mathcal{T}}_v$.

Combat starts at $t = t_0$ and continues as long as

$$[t, x(t)] \notin \text{int } \bar{\mathcal{T}}$$

where $\bar{\mathcal{T}} = \bar{\mathcal{T}}_u \cup \bar{\mathcal{T}}_v$ is the combat's extended terminal set and where $\text{int}(\cdot)$ denotes interior. We shall say that the combat terminates at time \bar{t} where

$$\bar{t} = \inf\{t > t_0 \mid [t, x(t)] \in \text{int } \bar{\mathcal{T}}\} . \quad (9)$$

If $\bar{t} = T^*$, we say that the combat ends in a draw. If $\bar{t} < T^*$, we say that player u (respectively, player v) wins the combat if there exists an $\epsilon > 0$ such that $[t, x(t)] \in \text{int } \bar{\mathcal{T}}_u$ (respectively, $[t, x(t)] \in \text{int } \bar{\mathcal{T}}_v$) for all $t > \bar{t}$ satisfying $t - \bar{t} \leq \epsilon$. If both players win the combat we speak of joint, or simultaneous, capture. Thus, the combat can terminate in one of the following four ways: (1) a win for player u ; (2) a win for player v ; (3) a draw; and (4) a joint capture.

To obtain a consistent formulation of the combat problem, it is necessary first to resolve its decidability question. That is, each initial event (t_0, x_0) must be uniquely and unambiguously classifiable into one of the four termination categories (1)-(4) above, thus partitioning the event space $\mathcal{R} \times \mathcal{R}^n$ into mutually exclusive regions ϕ_u , ϕ_v , ϕ_{uVv} , and ϕ_{uAv} , respectively.

To this end we define the players' termination preferences as follows. Player u ranks his preferences in order of priority as (1), (3), (4), (2), and player v ranks his preferences as (2), (3), (4), and (1).

Remark 1- This ranking is consistent with the intuitive notion that each player wishes to capture his opponent while not being captured himself. It also resolves the ambiguity that might occur in deciding between outcomes (3) and (4) when (1) and (2) cannot be forced by either of the players. This last point becomes clear if we observe that outcomes (3) and (4) can occur essentially in one of two ways: the players may be "locked into joint capture," in the sense that a unilateral attempt by one of the players to postpone termination will enable his opponent to win; on the other hand, if a player cannot force a win but has control over the time at which joint capture will occur, he will select the latest such time and, if possible, set it at T^* (i.e., a draw). \square

It is readily noted that by definition, the regions ϕ_u , ϕ_v , ϕ_{uVv} , and ϕ_{uAv} are invariant in the sense that there exist strategies for the players that maintain the resultant trajectory in its initial region until combat termination. Moreover, any sensible or, as we shall say, consistent strategies by the players will satisfy this invariance. Indeed, a trajectory will leave its initial region only if at least one of the players makes a fatal strategy error, in which case we say that the game strategies are inconsistent.

Remark 2- It is important to emphasize that, in properly formulated and correctly played combat, the winning capability of a player depends only on the problem data (including the initial state). No reversals of the winning capability (or "role") occur unless a fundamental error has been made by a player who relinquishes an advantage to his opponent. \square

We now associate with the combat problem a pair of differential games, one from the point of view of player u , or the u-game, and one from the point of view of player v , or the v-game.

The u-game G_u is defined as follows. Given is a cost functional

$$J_u = g_u[x(\bar{t}_u), \bar{t}_u] + \int_{t_0}^{\bar{t}_u} h_u[t, x(t), u(t), v(t)] dt, \quad (10)$$

with player u defined as the minimizer and player v as the maximizer. The terminal time \bar{t}_u is specified by

$$\bar{t}_u = \inf\{t > t_0 \mid [t, x(t)] \in \text{int } \bar{\mathcal{F}}_u\}, \quad (11)$$

subject to the event constraint

$$[t, x(t)] \notin \text{int } \bar{\mathcal{F}}_v \quad \forall \quad t_0 \leq t \leq \bar{t}_u. \quad (12)$$

The v-game G_v is defined as follows. Given is a cost functional

$$J_v = g_v[x(\bar{t}_v), \bar{t}_v] + \int_{t_0}^{\bar{t}_v} h_v[t, x(t), u(t), v(t)] dt, \quad (13)$$

with player v defined as the minimizer and player u as the maximizer. The terminal time \bar{t}_v is specified by

$$\bar{t}_v = \inf\{t > t_0 \mid [t, x(t)] \in \text{int } \bar{\mathcal{F}}_v\}, \quad (14)$$

subject to the event constraint

$$[t, x(t)] \notin \text{int } \bar{\mathcal{F}}_u \quad \forall \quad t_0 \leq t \leq \bar{t}_v. \quad (15)$$

We examine now the role of the two differential games in the formulation of the combat problem. First, note that if $(t_0, x_0) \in \Phi_u \cup \Phi_v$ exactly one of the games has feasible solutions (satisfying the terminal condition and event constraint) so that only the game of the winning player (the one with feasible solutions) can be played. The winning player will then choose his strategy to minimize his own cost functional (subject to the terminal and event constraints of the game); his opponent, realizing that he has no alternatives (having no feasible solutions to his own game), will play to maximize his opponent's cost. Thus a zero-sum game results with the winning player the minimizer and his opponent the maximizer.

In case $(t_0, x_0) \in \Phi_{uVv} \cup \Phi_{uAv}$, both games have feasible strategies, and the terminal times \bar{t}_u and \bar{t}_v coincide (to the least time in which each player can force capture of his opponent or a draw; see also Remark 1). In this case each player will choose to minimize his own cost functional (while ignoring his

opponent's). The resultant game is a nonzero-sum game with event and terminal constraints.

In summary, each player will choose his strategy to minimize the cost functional of his own game, unless for the given initial conditions his game has no feasible solution (that is, he is forced to lose the combat). In that case he will choose his strategy to maximize the cost of his opponent.

Definition 1- A combat problem formulated with the aid of dual differential games, and with strategy selections as described in table 1, is called a combat game. □

TABLE 1.- STRATEGY SELECTION RULES
IN COMBAT GAMES

Region	Φ_u	Φ_v	$\Phi_{uVv} \cup \Phi_{uAv}$
Strategy of u	min J_u	max J_v	min J_u
Strategy of v	max J_u	min J_v	min J_v

Remark 3- Within the dual differential games framework proposed in the present paper, rules for strategy selections other than the one described above may be chosen. For example, we might have decided to select the players' strategies to maximize their opponents' costs instead of minimizing their own costs when $(t_0, x_0) \in \Phi_{uVv} \cup \Phi_{uAv}$. Although this is logically consistent, we prefer the setup as proposed above since we find it more in line with expected intuitive response. From a purely mathematical standpoint it makes no essential difference what strategy selection rule is chosen so long as it is consistent and decidable. □

In games of combat in general, the terminal time is strongly influenced by the competing nature of the two differential games G_u and G_v . When $(t_0, x_0) \in \Phi_{uAv}$, the terminal time is forced to be the least time in which the players can, respectively, secure termination of their game, and the times for the two games coincide. Consequently, a case of special interest and simplicity (in terms of strategy selection), and one that is also of practical importance, is when $g_u = g_v = 0$ and $h_u = h_v = 1$; that is, the cost functionals of both games are the durations of the games. Thus in the time-optimal case, for $(t_0, x_0) \in \Phi_{uVv} \cup \Phi_{uAv}$ essentially every feasible strategy is optimal.

4. FORMULATION OF δ -COMBAT GAMES

With certain types of cost functionals, the combat game as formulated in section 3 may not have optimal strategies because the space of admissible trajectories is not closed. Specifically, because the target sets $\bar{\mathcal{T}}_u$ and $\bar{\mathcal{T}}_v$ are closed, their

(nonempty) intersection $\bar{\mathcal{T}}_u \cap \bar{\mathcal{T}}_v$ is also closed. Hence, the set $\bar{\mathcal{T}}_u^* := \bar{\mathcal{T}}_u / (\bar{\mathcal{T}}_u \cap \bar{\mathcal{T}}_v)$, the complement of $\bar{\mathcal{T}}_u \cap \bar{\mathcal{T}}_v$ in $\bar{\mathcal{T}}_u$, and the set $\bar{\mathcal{T}}_v^*$ (similarly defined), are not closed. As a result, a convergent sequence of winning trajectories for one of the players, say for player u , that terminates in $\bar{\mathcal{T}}_u^*$ need not converge to a trajectory that terminates at a point in $\bar{\mathcal{T}}_u^*$ but, rather, in $\bar{\mathcal{T}}_u \cap \bar{\mathcal{T}}_v$. However, then the limiting trajectory ends in joint capture and not in a win for u .

We now turn to reformulate the combat game to avoid the technical difficulties referred to above. To this end we introduce the concept of a δ -safety margin and a δ -combat game.

Let δ be a positive number and let $\bar{\mathcal{T}}_{u\Delta v}(\delta) := S_\delta(\bar{\mathcal{T}}_u \cap \bar{\mathcal{T}}_v)$ denote the open δ -neighborhood of $\bar{\mathcal{T}}_u \cap \bar{\mathcal{T}}_v$; that is, the set of all points $\phi := (t, x) \in \mathcal{R}^{n+1}$ whose (Euclidean) distance $d(\phi, \bar{\mathcal{T}}_u \cap \bar{\mathcal{T}}_v)$ from $\bar{\mathcal{T}}_u \cap \bar{\mathcal{T}}_v$ is less than δ . Let

$\bar{\mathcal{T}}_u(\delta) := \bar{\mathcal{T}}_u / \bar{\mathcal{T}}_{u\Delta v}(\delta)$ denote the points of $\bar{\mathcal{T}}_u$ that are not in $\bar{\mathcal{T}}_{u\Delta v}(\delta)$. Similarly define $\bar{\mathcal{T}}_v(\delta)$.

The δ -combat starts at time $t = t_0$ and continues as long as

$$[t, x(t)] \notin \text{int}[\bar{\mathcal{T}} \cup \bar{\mathcal{T}}_{u\Delta v}(\delta)] .$$

We shall say that combat terminates at time $t = \bar{t}$ where

$$\bar{t} := \inf\{t > t_0 \mid [t, x(t)] \in \text{int}[\bar{\mathcal{T}} \cup \bar{\mathcal{T}}_{u\Delta v}(\delta)]\} . \quad (16)$$

The winning conditions of the δ -combat differ, however, from those of the "ordinary" combat as follows.

We say that the δ -combat ends in a δ -draw if $\bar{t} = T^* - \delta$. However, if $\bar{t} < T^* - \delta$ we distinguish between the following outcomes. We say that player u wins if

$$[\bar{t}, x(\bar{t})] \in \bar{\mathcal{T}}_u(\delta) , \quad (17)$$

that v wins if

$$[\bar{t}, x(\bar{t})] \in \bar{\mathcal{T}}_v(\delta) , \quad (18)$$

and that the combat ends in joint δ -capture if both players win.

The δ -combat, similarly to ordinary combat, can end (1) by u winning, (2) by v winning, (3) in a δ -draw, or (4) in joint δ -capture. The players' termination preferences are now defined as follows: Player u ranks his preferences in order of priority as (1) u wins, (2) a δ -draw or joint δ -capture, and (3) v wins. Player v ranks his preferences in reversed order. As discussed in some more detail below, no prior preference distinction is made between δ -draw and joint δ -capture.

Given the above termination preferences it is clear that for an initial event (t_0, x_0) , one of the players, say player u , can win the δ -combat game if, and only if, he can select a strategy with which he will win the game against every possible strategy of his opponent. We shall then say that (t_0, x_0) is in u 's δ -winning zone, denoted $\Phi_u(\delta)$. Similarly we can define $\Phi_v(\delta)$, the δ -winning zone of v .

The fundamental difference between the ordinary combat problem and the δ -combat problem is that in the latter case the winning terminal sets $\bar{\mathcal{T}}_u(\delta)$ and $\bar{\mathcal{T}}_v(\delta)$ are closed and $\bar{\mathcal{T}}_u(\delta) \cap \bar{\mathcal{T}}_v(\delta) = \emptyset$. Thus u winning and v winning cannot occur simultaneously, and in formulating the δ -combat game we have to proceed somewhat differently than for an ordinary combat problem.

To obtain optimal strategies, we associate with the δ -combat problem a pair of cost functionals J_u , the cost for player u , and J_v , the cost for player v . These are defined by

$$J_u = g_u[x(\bar{t}), \bar{t}] + \int_{t_0}^{\bar{t}} h_u[t, x(t), u(t), v(t)] dt \quad (19)$$

and

$$J_v = g_v[x(\bar{t}), \bar{t}] + \int_{t_0}^{\bar{t}} h_v[t, x(t), u(t), v(t)] dt \quad (20)$$

where g_u , g_v , h_u , and h_v are suitably defined smooth real functions.

If the initial event $[t_0, x_0] \in \Phi_u(\delta)$, that is, player u has winning strategies, he will choose his strategy to minimize J_u subject to the termination constraint (17) and to the event constraint

$$[t, x(t)] \notin \text{int}[\bar{\mathcal{T}}_{u \wedge v}(\delta) \cup \bar{\mathcal{T}}_v] \quad \forall t_0 \leq t \leq \bar{t}.$$

Player v , having no feasible (winning) strategies, will play to maximize player u 's cost functional J_u . The resultant game is a zero-sum event-constrained differential game with player u minimizing, and player v maximizing, the cost functional J_u . The responsibility of satisfying the event constraint rests with player u , while v tries to violate it.

Conversely, if $[t_0, x_0] \in \Phi_v(\delta)$, the roles of players u and v are reversed. The relevant cost functional becomes (20) and the event constraint is

$$[t, x(t)] \notin \text{int}[\bar{\mathcal{T}}_{u \wedge v}(\delta) \cup \bar{\mathcal{T}}_u] \quad \forall t_0 \leq t \leq \bar{t}.$$

There remains the case when the initial event $[t_0, x_0]$ is neither in $\Phi_u(\delta)$ nor in $\Phi_v(\delta)$. Clearly no winning strategies exist for either player in this case (in respect to the δ -combat game). However, it is still possible that for some smaller $\hat{\delta} > 0$, $(t_0, x_0) \in \Phi_u(\hat{\delta}) \cup \Phi_v(\hat{\delta})$. In that case winning strategies can be selected for

the players just as before but in respect to the $\hat{\delta}$ -game instead of the δ -game. If, on the other hand, $(t_0, x_0) \notin \Phi_u(\delta') \cup \Phi_v(\delta')$ for all $\delta' > 0$, then it follows that $(t_0, x_0) \in \Phi_{uVv} \cup \Phi_{uAv}$ where Φ_{uVv} is the draw region and Φ_{uAv} is the joint capture region of the game as defined earlier. In this case we adopt the preference ordering between a draw and a joint capture as established earlier for (ordinary) combat games; that is, the players prefer a draw to joint capture. In either case the players choose their strategies so as to minimize their own cost functionals resulting in a nonzero-sum game.

5. EXAMPLE OF A COMBAT GAME: THE TURRET GAME

Formulation

To illustrate the theory just developed we consider a combat game (the turret game) that represents a simplified version of the air combat situation discussed qualitatively in section 2.

Player u moves in a plane with arbitrary velocity relative to a fixed reference frame (X, Y) , and can turn a ray weapon relative to a fixed direction at a bounded angular rate $\dot{\alpha}$ (see fig. 2). Player v moves so that he is always at a distance R from u , and he can traverse this circle at an angular speed relative to a fixed direction at a bounded rate $\dot{\beta}$. Player v also has a ray weapon that he can turn relative to the line of sight between the two players at a bounded rate $\dot{\phi}$.

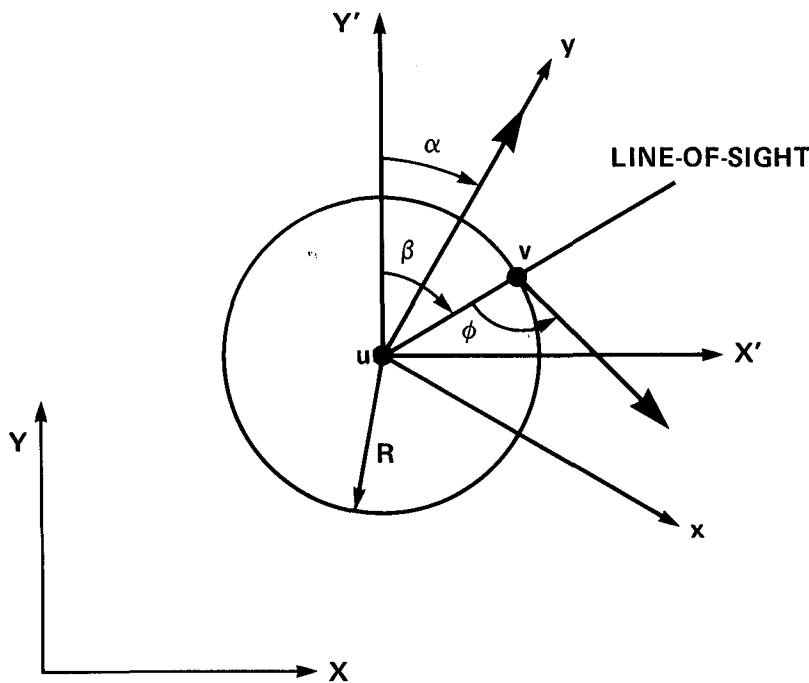

Figure 2.- Turret game in fixed reference frame.

For convenience we represent the problem in a relative reference frame with origin at u 's position and the y -axis along u 's weapon (fig. 3). Letting $x_1 = \beta - \alpha$, $x_2 = \phi$, $u = \dot{\alpha}$, $v_1 = \dot{\beta}$, and $v_2 = -\dot{\phi}$, the kinematical equations of motion are

$$\dot{x}_1 = v_1 - u, \quad x_1(0) = x_1^0 \quad (21)$$

$$\dot{x}_2 = -v_2, \quad x_2(0) = x_2^0 \quad (22)$$

with x_1 and x_2 being computed modulo 2π , and where we take $t_0 = 0$ since the system is autonomous. In view of the circular symmetry of the problem, it is easily seen that the playing space of interest is

$$P = \{(x_1, x_2) | x_1 \in [0, \pi], x_2 \in [0, \pi]\} \quad (23)$$

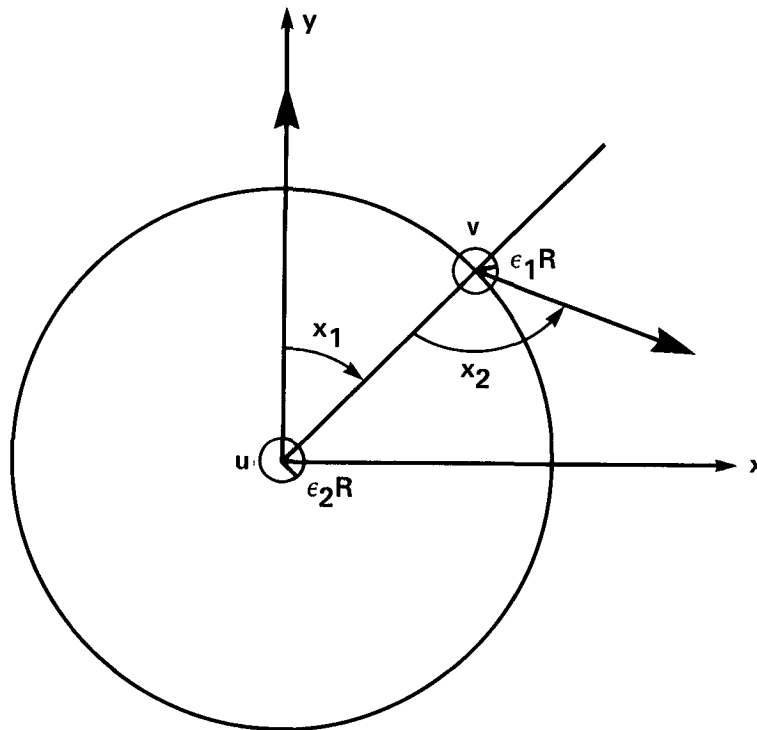

Figure 3.- Turret game in relative reference frame.

The admissible controls are specified within the bounds

$$0 \leq u \leq \bar{u} \quad (24)$$

and

$$(v_1, v_2) \in V \subset \mathcal{R}_+^2, \quad (25)$$

where \mathcal{R}_+^2 is the positive quadrant of \mathcal{R}^2 .

Next, we choose T^* , the maximum allowed time duration of the combat. The extended targets are then given by

$$\bar{\mathcal{T}}_u = \{(t, x_1, x_2) \in \mathcal{R} \times P \mid \text{either } (x_1 \leq \epsilon_1 \text{ and } t < T^*) \text{ or } (t \geq T^*)\}$$

and

$$\bar{\mathcal{T}}_v = \{(t, x_1, x_2) \in \mathcal{R} \times P \mid \text{either } (x_2 \leq \epsilon_2 \text{ and } t < T^*) \text{ or } (t \geq T^*)\}$$

where $\epsilon_1 R$ and $\epsilon_2 R$ are the radii of the vulnerability regions or capture sets of the two players (fig. 3). The extended joint capture region $\bar{\mathcal{T}}_u \cap \bar{\mathcal{T}}_v$ is given by

$$\begin{aligned} \bar{\mathcal{T}}_u \cap \bar{\mathcal{T}}_v = \{(t, x_1, x_2) \in \mathcal{R} \times P \mid & \text{either } (x_1 \leq \epsilon_1 \text{ and } x_2 \leq \epsilon_2, \text{ if } t < T^*) \\ & \text{or } (t \geq T^*)\}. \end{aligned}$$

In the ensuing discussion we shall, for the most part, assume that T^* is sufficiently large so that we can ignore the t dimension of the target. Thus we shall refer to the (ordinary) target sets (see fig. 4)

$$\mathcal{T}_u = \{(x_1, x_2) \in P \mid x_1 \leq \epsilon_1\}$$

$$\mathcal{T}_v = \{(x_1, x_2) \in P \mid x_2 \leq \epsilon_2\}$$

$$\mathcal{T}_u \cap \mathcal{T}_v = \{(x_1, x_2) \in P \mid x_1 \leq \epsilon_1, x_2 \leq \epsilon_2\}.$$

Upon specifying the safety margin $\delta > 0$, we obtain the δ -winning zones as depicted in figure 5. The δ -combat terminates at time $\bar{t} < T^* - \delta$ with one of the players winning if \bar{t} is the first time the state intercepts the set $\mathcal{T}_u(\delta) \cup \mathcal{T}_v(\delta)$ with an inward velocity. The δ -capture of v by u occurs (if it occurs at all) if at termination with $\bar{t} < T^* - \delta$,

$$w_1(\bar{t}) = \epsilon_1, x_2(\bar{t}) \geq \epsilon_2 + \delta \quad \text{and} \quad \dot{x}_1(\bar{t}) < 0. \quad (26)$$

Similarly, δ -capture of u by v occurs if at termination with $\bar{t} < T^* - \delta$,

$$x_1(\bar{t}) \geq \epsilon_1 + \delta, x_2(\bar{t}) = \epsilon_2 \quad \text{and} \quad \dot{x}_2(\bar{t}) < 0. \quad (27)$$

Alternatively, combat terminates either in joint δ -capture or in a δ -draw.

Next we will analyze this game for different cases (linear and circular control constraints) and for different cost functionals (quadratic and time-optimal).

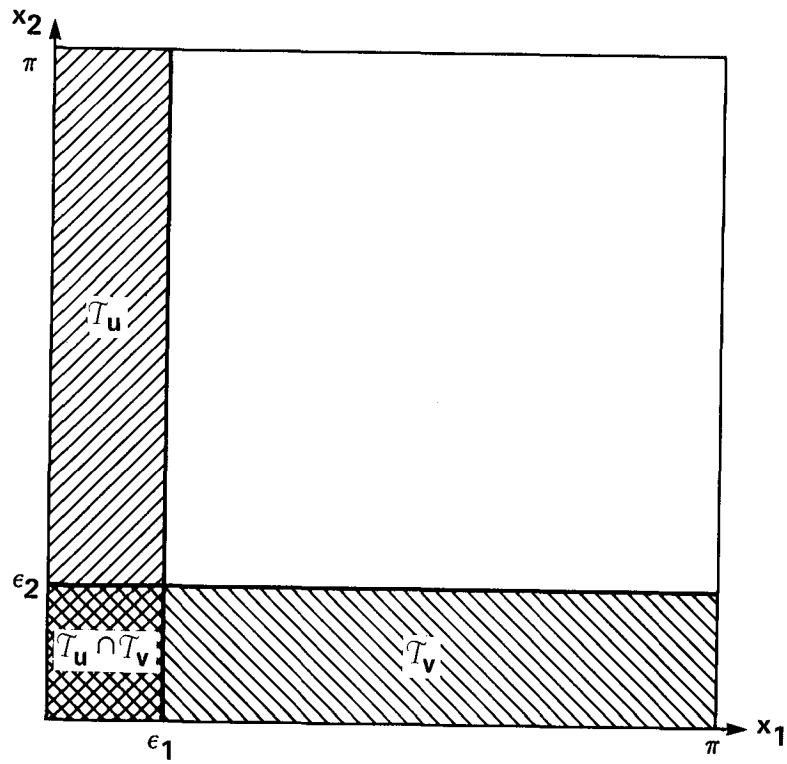

Figure 4.- Ordinary target sets.

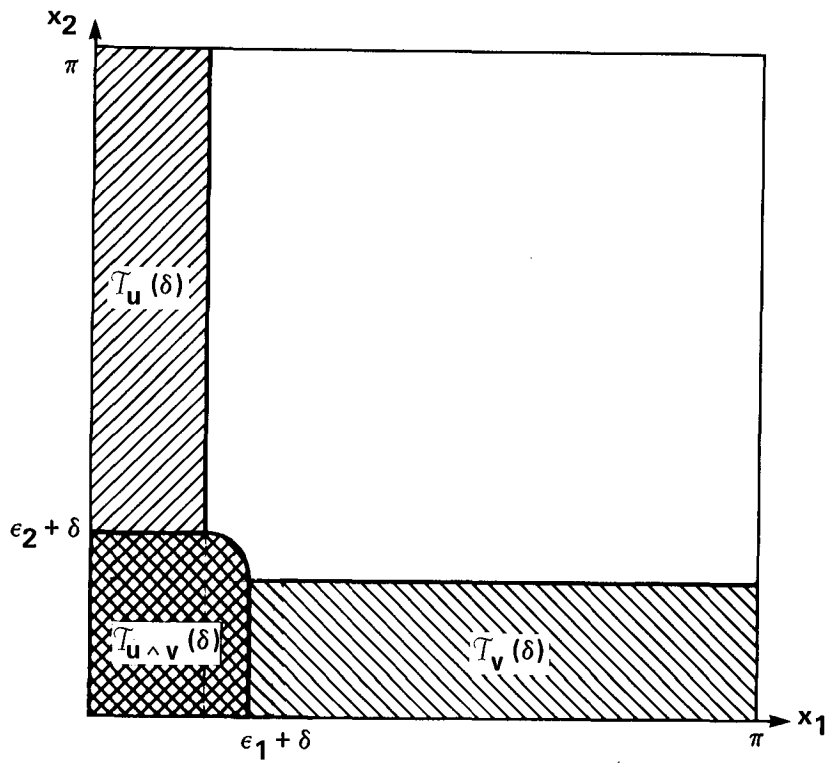

Figure 5.- δ -capture sets.

Linear Control Constraint

Let V (fig. 6) be given by

$$v_1 \geq 0, \quad v_2 \geq 0, \quad \frac{v_1}{\bar{v}_1} + \frac{v_2}{\bar{v}_2} \leq 1, \quad (28)$$

where \bar{v}_1 and \bar{v}_2 are preselected positive bounds. (This case may be viewed as a convexification and approximation of the typical situation in which v 's motion is limited by a lateral acceleration constraint specified by $v_1 v_2 \leq k_1$ and by bounds $v_1 \leq k_2$ and $v_2 \leq k_3$, the dashed lines on figure 6).

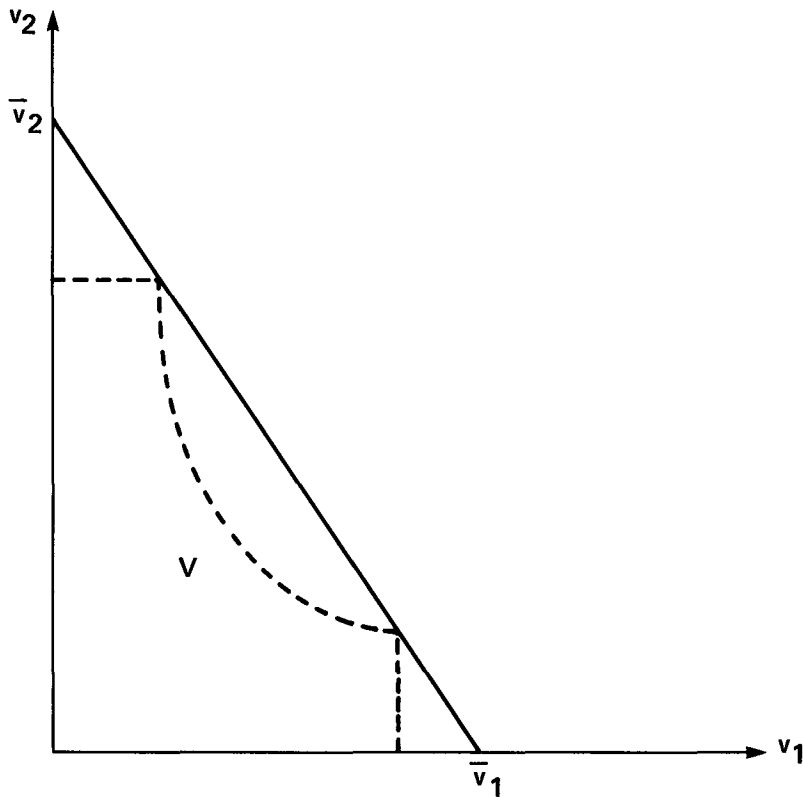

Figure 6.- Linear control constraint.

The cost functionals are chosen as

$$J_u = -C_1 x_2^2 \Big|_{\bar{t}} + C_2 \int_0^{\bar{t}} dt, \quad (29)$$

and

$$J_v = -C_1 x_1^2 \Big|_{\bar{t}} + C_2 \int_0^{\bar{t}} dt, \quad (30)$$

where C_1 and C_2 are positive constants. These cost functionals reflect the combined (weighted) objective of the winning player, that of minimizing the termination time while securing maximum safety (i.e., the maximum final distance from the opponent's target set), and the converse objective for the losing player.

Before beginning the detailed analysis of optimal strategies, we examine the implications of the termination conditions (26) and (27). First, note that v can always win from suitable initial conditions because, from equations (22) and (28), he can always satisfy the third condition of equation (27). On the other hand, for u to win he must be able to force the third condition of equation (26), $\dot{x}_1(\bar{t}) < 0$; this implies, using (21), (24), and (28), that

$$\bar{u} > \bar{v}_1 \quad (31)$$

must hold. Thus, the relative magnitudes of \bar{u} and \bar{v}_1 are of key importance and we begin by studying the game with (31) holding.

First, consider u 's winning δ -game. In this game u wishes to minimize and v to maximize J_u in equation (29). In order to employ the standard necessary conditions, the Hamiltonian is defined by

$$H = \lambda_0 C_2 + \lambda_1 (v_1 - u) - \lambda_2 v_2. \quad (32)$$

We may set $\lambda_0 = 1$ (since $\lambda_0 = 0$ adds no new candidates for optimal control) and λ_1 and λ_2 are constants (because H does not depend on x_1 or x_2). If u^* , v_1^* , and v_2^* are optimal controls, then

$$u^*, v_1^*, v_2^* = \arg(\min_{0 \leq u \leq \bar{u}} \max_{v_1, v_2 \in V} H), \quad (33)$$

and

$$H(\lambda_1, \lambda_2, u^*, v_1^*, v_2^*) = 0. \quad (34)$$

The termination condition is

$$\bar{x}_1 = x_1(\bar{t}) = \epsilon_1. \quad (35)$$

The state constraint is $x(t) \notin \text{int}[\mathcal{S}_v \cup \mathcal{S}_{u \Delta v}(\delta)] \forall t \in [0, \bar{t}]$, or

$$\left\{ \begin{array}{l} x_2 \geq \varepsilon_2 + \delta, \quad x_1 \leq \varepsilon_1 \\ x_2 \geq \varepsilon_2 + \sqrt{\delta^2 - (x_1 - \varepsilon_1)^2}, \quad \varepsilon_1 < x_1 < \varepsilon_1 + \delta \\ x_2 \geq \varepsilon_2, \quad \varepsilon_1 + \delta \leq x_1 \end{array} \right\} \quad \forall t \in [0, \bar{t}] . \quad (36)$$

From equation (29), the transversality conditions give λ_2 as

$$\lambda_2 = \lambda_2(\bar{t}) = \partial J_u / \partial x_2 = -2C_1 x_2(\bar{t}) < 0 . \quad (37)$$

Therefore, we may write equation (32) as

$$H = C_2 + \lambda_1(v_1 - u) + 2C_1 \bar{x}_2 v_2 , \quad (38)$$

where $\bar{x}_2 = x_2(\bar{t})$.

To determine the optimal controls from equations (33) and (34), the sign of λ_1 is needed. If $\lambda_1 < 0$, then from equations (33) and (38) $v_1^* = 0$, $v_2^* = \bar{v}_2$, and $u^* = 0$; therefore, H is the sum of two positive terms, violating condition (34). Similarly, $\lambda_1 = 0$ leads to violation of (34) and thus

$$\lambda_1 > 0 . \quad (39)$$

It follows that the optimal control for u is

$$u^* = \bar{u} \quad (40)$$

and the optimal controls for v are

$$v_1^*, v_2^* = \arg \left[\max_{v_1, v_2 \in V} (\lambda_1 v_1 + 2C_1 \bar{x}_2 v_2) \right] . \quad (41)$$

The optimal solution of this simple linear programming problem will always lie on the constraint

$$v_2 = -\frac{\bar{v}_2}{\bar{v}_1} v_1 + \bar{v}_2 , \quad 0 \leq v_1 \leq \bar{v}_1 \quad (42)$$

so that equation (41) becomes

$$v_1^* = \arg \left[\max_{0 \leq v_1 \leq \bar{v}_1} (\lambda_1 - 2C_1 \bar{x}_2 \bar{v}_2 / \bar{v}_1) v_1 \right] . \quad (43)$$

There are three possibilities:

$$\lambda_1 > 2C_1 \bar{x}_2 \bar{v}_2 / \bar{v}_1 \Rightarrow v_1^* = \bar{v}_1, \quad v_2^* = 0, \quad (44a)$$

$$\lambda_1 < 2C_1 \bar{x}_2 \bar{v}_2 / \bar{v}_1 \Rightarrow v_1^* = 0, \quad v_2^* = \bar{v}_2, \quad (44b)$$

$$\lambda_1 = 2C_1 \bar{x}_2 \bar{v}_2 / \bar{v}_1 \Rightarrow v_1^*, v_2^* \text{ singular}. \quad (44c)$$

Next, consider v 's winning δ -game with condition (31) holding. Now, u wishes to maximize and v to minimize equation (30) subject to the termination condition

$$\bar{x}_2 = x_2(\bar{t}) = \epsilon_2 \quad (45)$$

and the state constraint

$$\left. \begin{cases} x_1 \geq \epsilon_1 + \delta, & x_2 \leq \epsilon_2 \\ x_1 \geq \epsilon_1 + \sqrt{\delta^2 - (x_2 - \epsilon_2)^2}, & \epsilon_2 < x_2 < \epsilon_2 + \delta \\ x_1 \geq \epsilon_1, & \epsilon_2 + \delta \leq x_2 \end{cases} \right\} \forall t \in [0, \bar{t}]. \quad (46)$$

Proceeding as before, we conclude that $\lambda_1 = -2C_1 \bar{x}_1$, $u^* = \bar{u}$, $\lambda_2 > 0$, and v 's possible optimal controls are as given by (44a), (44b), and (44c); however, in this case only the choice (44b) satisfies (34).

We are now in a position to delineate the winning regions $\Phi_u(\delta)$ (u wins) and $\Phi_v(\delta)$ (v wins). Player u 's winning δ -game will be feasible if, and only if, he is able to satisfy equations (35) and (36) for all of player v 's admissible controls. At the boundary of $\Phi_u(\delta)$, v will just be able to make (36) an equality with controls (44b). With this choice of controls, (35) and (36) give

$$\bar{t} = \frac{x_1^0 - \epsilon_1}{\bar{u}} \leq \frac{x_2^0 - \epsilon_2 - \delta}{\bar{v}_2},$$

that is,

$$\frac{x_2^0 - \epsilon_2 - \delta}{x_1^0 - \epsilon_1} \geq \frac{\bar{v}_2}{\bar{u}} =: \gamma_2, \quad (47)$$

which defines $\Phi_u(\delta)$.

Similarly, v 's winning δ -game will be feasible if, and only if, (45) and (46) are satisfied. At the boundary of $\Phi_v(\delta)$, v can just achieve (45) with (46) an equality at $t = \bar{t}$ and his controls thus will be (44b) here. Integrating (21) and

(22) with this control choice and using (46), the specification of the region $\Phi_V(\delta)$ is obtained as

$$\frac{x_2^0 - \epsilon_2}{x_1^0 - \epsilon_1 - \delta} \leq \gamma_2 . \quad (48)$$

The curves defined by equalities in (47) and (48) divide the playing space into regions of different outcomes and, therefore, following Isaacs (ref. 2), may be termed δ -barriers.

We now determine v 's optimal controls in region $\Phi_U(\delta)$. First, suppose (44a) holds; substituting $v_1^* = \bar{v}_1$ and $v_2^* = 0$ in (38) and invoking (34) gives

$$\lambda_1 = \frac{C_2}{\bar{u} - \bar{v}_1} . \quad (49)$$

Putting (49) in (44a) then gives

$$\bar{x}_2 < \frac{C_2 \gamma_1}{2C_1 \gamma_2 \bar{u} (1 - \gamma_1)} \quad (50)$$

where $\gamma_1 = \bar{v}_1 / \bar{u}$. From (22) the extremal trajectories in this case are parallel to the x_1 -axis and this, together with (50), defines the region $\Phi_U^{(1)}(\delta)$ in figure 7(a). Next suppose (44b) holds; substituting $v_1^* = 0$ and $v_2^* = \bar{v}_2$ in (38) and invoking (34) results in

$$\lambda_1 = \frac{C_2 + 2C_1 \bar{x}_2 \bar{v}_2}{\bar{u}} \quad (51)$$

and putting this in (44b) then gives

$$\bar{x}_2 > \frac{C_2 \gamma_1}{2C_1 \gamma_2 \bar{u} (1 - \gamma_1)} . \quad (52)$$

In this case, from (21) and (22) the trajectories are parallel to the bounding line of $\Phi_U(\delta)$ as defined by (47) with equality; this, along with (52), defines

$\Phi_U^{(2)}(\delta)$. The last possibility is (44c) for which the controls need satisfy only

(42), and

$$\lambda_1 = \frac{2C_1 \bar{x}_2 \bar{v}_2}{\bar{v}_1} . \quad (53)$$

Substituting (53) into (38) and using (34) and (42), we arrive at

$$\bar{x}_2 = \frac{C_2 \gamma_1}{2C_1 \gamma_2 \bar{u}(1 - \gamma_1)} := \hat{x}_2 . \quad (54)$$

Therefore, all optimal trajectories in the remaining region, $\Phi_u^{(3)}(\delta)$, terminate at (ϵ_1, \hat{x}_2) . Because of the linearity of (21), (22), and (28), all paths using any sequence of controls satisfying (42) and reaching (ϵ_1, \hat{x}_2) without violating the constraint will take the same time and hence have the same cost; thus the optimal controls and paths are not unique in this case. The region $\Phi_u(\delta)$ is then given by

$$\Phi_u(\delta) = \bigcup_{i=1}^3 \Phi_u^{(i)}(\delta) .$$

We can now completely specify the optimal strategies in the winning regions $\Phi_u(\delta)$ and $\Phi_v(\delta)$ for the two players for the case (31). In $\Phi_u^{(1)}(\delta)$, v plays (44a) until termination and in $\Phi_u^{(2)}(\delta)$ he plays (44b) until termination. In $\Phi_u^{(3)}(\delta)$, v plays any sequence satisfying (42) giving termination at (ϵ_1, \hat{x}_2) . In the region $\Phi_v(\delta)$, v plays (44b). Player u plays \bar{u} in all winning regions. The partition of the playing space is described in figure 7(a) for the case

$$\epsilon_2 + \delta < \frac{C_2 \gamma_1}{2C_1 \gamma_2 \bar{u}(1 - \gamma_1)} < \pi .$$

Player v 's winning region is denoted $\Phi_v^{(1)}(\delta)$ in this figure for reasons which will become apparent subsequently. This figure also shows example optimal trajectories in each winning region.

For initial states satisfying neither (47) nor (48) [i.e., for $(x_1^0, x_2^0) \notin \Phi_u(\delta) \cup \Phi_v(\delta)$], but satisfying one of these conditions for some $\hat{\delta} < \delta$, the preceding analysis applies with $\hat{\delta}$ replacing δ .

It remains to resolve the combat for initial states satisfying neither (47) nor (48) for all positive $\hat{\delta}$ no matter how small. These states lie on a line of slope γ_2 passing through the point (ϵ_1, ϵ_2) , given by the dashed line in figure 7(a), and for points on this line we must have $(x_1^0, x_2^0) \in \Phi_{u \vee v} \cup \Phi_{u \wedge v}$. Further, since under condition (31) there can never be a draw (u will always eventually win with $u^* = \bar{u}$ unless v does so first), we have in fact joint capture, or $(x_1^0, x_2^0) \in \Phi_{u \wedge v}$. The unique strategies that give this outcome are (40) and (44b) and any unilateral deviation from these strategies will result in the capture of the deviating player. The locus of points $(x_1, x_2) \in \Phi_{u \wedge v}$ is therefore a "barrier" in Isaac's terminology (ref. 2), and could have been determined as the semipermeable surface emanating from the intersection of \mathcal{F}_u and \mathcal{F}_v .

$$\textcircled{1} \quad x_2^0 = \gamma_2 (x_1^0 - \epsilon_1) + \frac{c_2 \gamma_1}{2c_1 \gamma_2 \bar{u} (1 - \gamma_1)}$$

$$\textcircled{2} \quad x_2^0 = \gamma_2 (x_1^0 - \epsilon_1 - \delta) + \epsilon_2$$

$$\textcircled{3} \quad x_2^0 = \gamma_2 (x_1^0 - \epsilon_1) + \epsilon_2 + \delta$$

$$\textcircled{4} \quad x_2^0 = \frac{c_2 \gamma_1}{2c_1 \gamma_2 \bar{u} (1 - \gamma_1)}$$

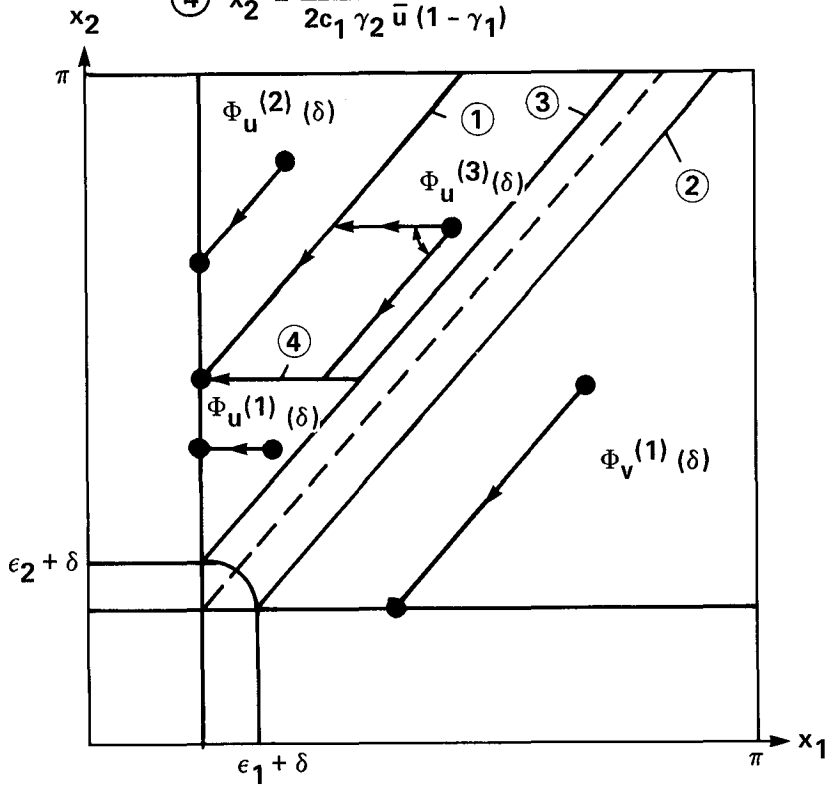

(a) $\gamma_1 < 1$.

Figure 7.- Regions and optimal trajectories in the playing space; turret game with linear control constraint and quadratic cost.

Next, we consider the case

$$\bar{u} = \bar{v}_1 . \tag{55}$$

In this case, v can always prevent the third condition of (26) from being satisfied and thus u can never win (from initial states outside the target's interior). Therefore, only v 's winning game need be considered. Reasoning exactly as before, the region $\Phi_v^{(1)}(\delta)$ is defined by (48) and the optimal controls in this region are (40) and (44b).

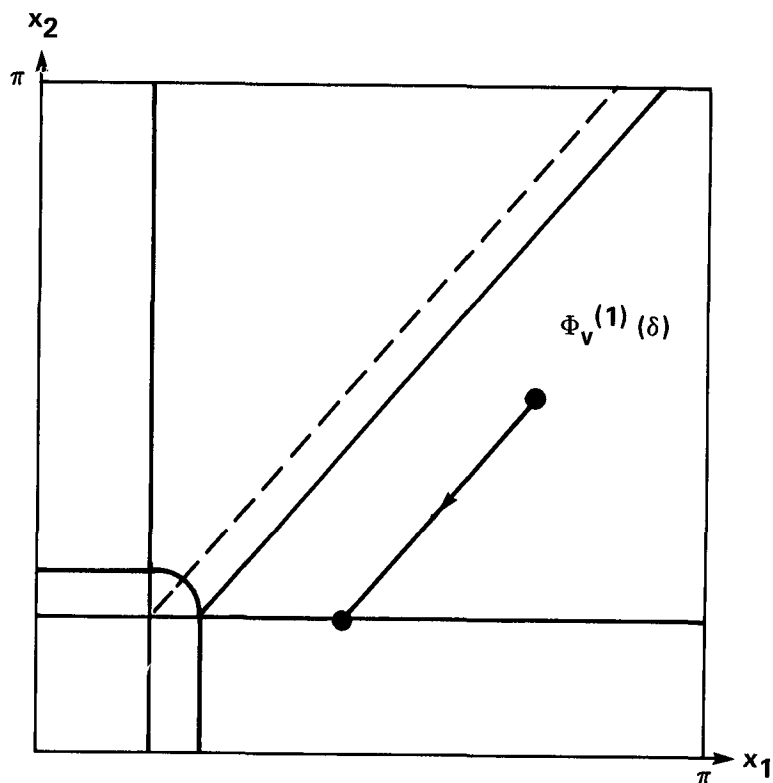

(b) $\gamma_1 = 1$.

Figure 7.- Continued.

From initial states in the region complementary to $\Phi_v^{(1)}(\delta)$, consisting of points (x_1^0, x_2^0) satisfying

$$\frac{x_2^0 - \epsilon_2}{x_1^0 - \epsilon_1 - \delta} > \gamma_2,$$

a simple calculation using (21), (22), (42), and (55), shows that neither player can win the game with a δ -margin. Hence, the game will end either in a δ -draw or in joint δ -capture.

Letting δ become vanishingly small, the boundary line of $\Phi_v^{(1)}(\delta)$ converges to the dashed line emanating from the point (ϵ_1, ϵ_2) in figure 7(b). All points below this line are thus in $\Phi_v^{(1)}(\hat{\delta})$ for some $\hat{\delta} > 0$. It is readily seen that from all points above the dashed line, both players can secure at least a draw; for example, by using strategies (40) and (44a) for all $t < T^* - \delta$, although draw strategies are nonunique for both players. Thus, points in this region are in Φ_{uVv} .

From points on the dashed line u must play strategy (40), otherwise v will have winning strategies. On the other hand, if v uses strategies satisfying (42),

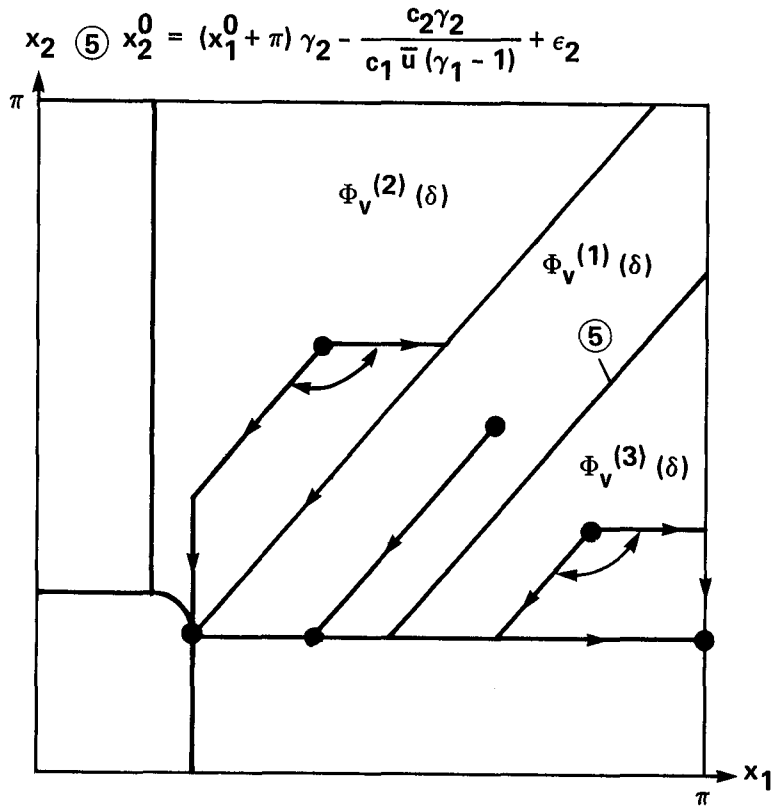

(c) $\gamma_1 > 1$.

Figure 7.- Concluded.

with u playing (40), the outcome will be either draw or joint capture. By the preference order established for ordinary combat, v chooses a draw. An example of a draw strategy for v is to play (44a) for all $t \leq T^* - \delta$, but draw strategies are not unique for v .

The regions with (55) holding are shown in figure 7(b), along with example optimal trajectories.

The last case to consider is

$$\bar{u} < \bar{v}_1 . \tag{56}$$

From (21), (22), (26), and (27), it is obvious that now v can capture u from any position in the playing space P that is not in the interior of u 's target, and therefore $\Phi_v(\delta) = P / \text{int } \mathcal{F}_u(\delta)$. The necessary conditions again give (40) as u 's optimal control and show that v 's optimal controls will lie on (42). In this case, however, the necessary conditions do not establish the sign of λ_2 ; further, the optimal controls of v are frequently nonunique, and the optimal trajectories are frequently on the boundaries of the playing space. This means that the necessary conditions are of little use in determining v 's optimal controls and we use direct comparison of cost functionals instead.

The minimum time-to-capture from an arbitrary point (x_1^0, x_2^0) in the region (48) is obtained from using controls (44b) in (21) and (22); the result is

$$t' = (x_2^0 - \epsilon_2) / \bar{v}_2 .$$

At this time,

$$x_1' = -(x_2^0 - \epsilon_2) / \gamma_2 + x_1^0$$

and thus from (30),

$$J'_v = -C_1 [x_2^0 - (x_2^0 - \epsilon_2) / \gamma_2]^2 + C_2 (x_2^0 - \epsilon_2) / \bar{v}_2 .$$

At t' , v has the option of forcing penetration immediately or of playing controls (44a) and forcing penetration of his target at some later point x_1'' at an additional time increment t'' . Again from (21),

$$x_1'' = (\bar{v}_1 - \bar{u})t'' + x_1'$$

and the cost is

$$J''_v = -C_1 x_1''^2 + C_2 \left[\frac{x_2^0 - \epsilon_2}{\bar{v}_2} + \frac{x_1'' + (x_2^0 - \epsilon_2) / \gamma_2 - x_1^0}{\bar{v}_1 - \bar{u}} \right] \quad (57)$$

But this function will have a minimum with respect to $x_1'' \in [x_1', \pi]$ at either $x_1'' = x_1'$ or $x_1'' = \pi$. Thus, we need to compare the cost (57) for $x_1'' = x_1'$ with that for $x_1'' = \pi$. The result is that the minimum-time path will be optimal if

$$x_1^0 + \pi - \frac{x_2^0 - \epsilon_2}{\gamma_2} < \frac{C_2}{C_1 \bar{u} (\gamma_1 - 1)} \quad (58)$$

and the path ending at (π, ϵ_2) will be optimal when inequality (58) is reversed. Note that because of the linearity of (21), (22), and (42), all paths using any sequence of controls satisfying (42) and reaching (π, ϵ_2) without violating the constraints will take the same time. Thus the optimal controls and paths are not unique in this case.

The line separating the two regions (obtained by replacing the inequality by equality in (58)) has slope γ_2 and is thus parallel to the minimum time paths. This surface intercepts v 's target at $C_2 / [C_1 \bar{u} (\gamma_1 - 1)] - \pi$.

The regions and example trajectories are shown in figure 7(c) for the case (56) and the condition $\epsilon_1 + \delta < C_2 / [C_1 \bar{u} (\gamma_1 - 1)] - \pi < \pi$. The optimal paths in region $\Phi_v^{(2)}(\delta)$ are nonunique (only the two extreme paths are shown), and all end at $(\epsilon_1 + \delta, \epsilon_2)$ in minimum time; the paths in $\Phi_v^{(1)}(\delta)$ are unique, and minimum time; and the paths in $\Phi_v^{(3)}(\delta)$ are nonunique, and all end at (π, ϵ_2) . If

$C_2/[C_1\bar{u}(\gamma_1 - 1)] - \pi < \varepsilon_1 + \delta$, all optimal trajectories end at (π, ε_2) and if $C_2/[C_1\bar{u}(\gamma_1 - 1)] > 2\pi$ all trajectories are minimum time.

A special case of these results is time-optimality ($C_1 = 0$ and $C_2 = 1$). In this case, the regions in which the optimal trajectories are not time-optimal vanish (specifically, $\phi_u^{(2)}(\delta)$, $\phi_u^{(3)}(\delta)$, and $\phi_v^{(3)}(\delta)$ in figs. 7(a), 7(b), and 7(c). Also, in region (48) u's control is not defined since it has no effect on the outcome of the game. These results are summarized in figures 8(a), 8(b), and 8(c); the optimal strategies in each region are apparent.

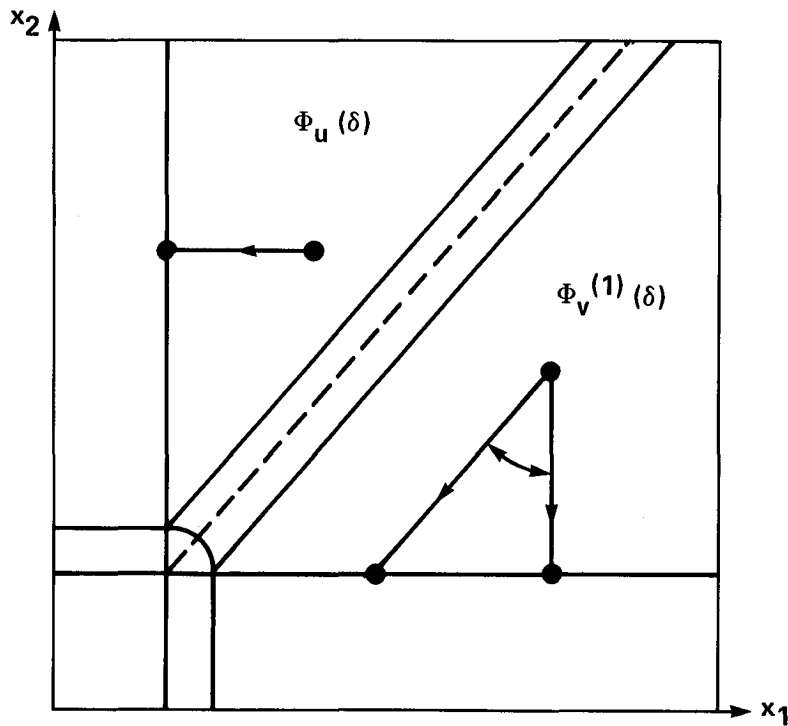

(a) $\gamma_1 < 1$.

Figure 8.- Regions and optimal trajectories in the playing space; turret game with linear control constraint and time-optimality.

Circular Control Constraint

Now let V (fig. 9) be given by

$$v_1 \geq 0, \quad v_2 \geq 0, \quad v_1^2 + v_2^2 \leq \bar{v}^2, \quad (59)$$

where \bar{v} is a preselected positive bound, and choose both costs as time-to-capture

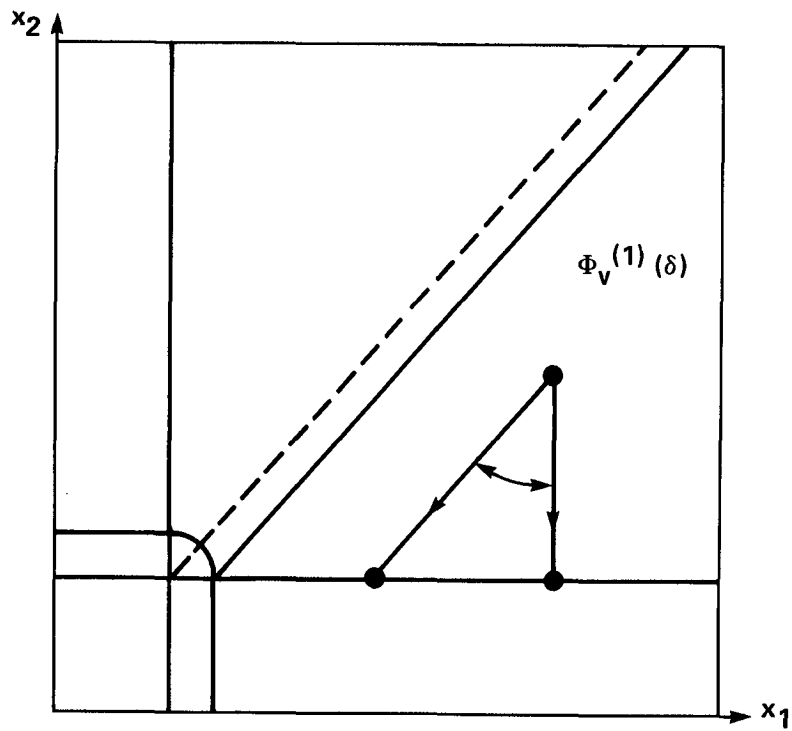

(b) $\gamma_1 = 1$.

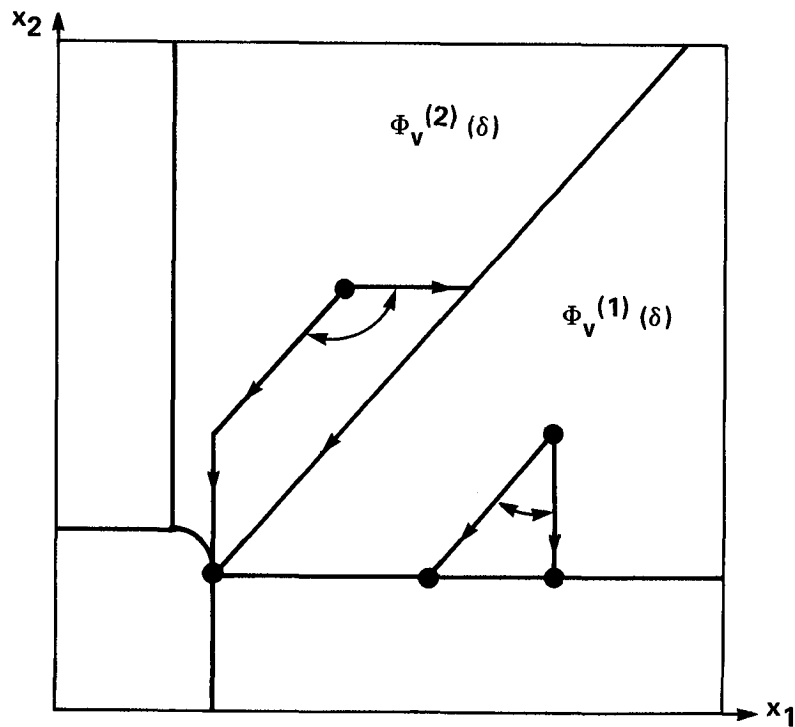

(c) $\gamma_1 > 1$.

Figure 8.- Concluded.

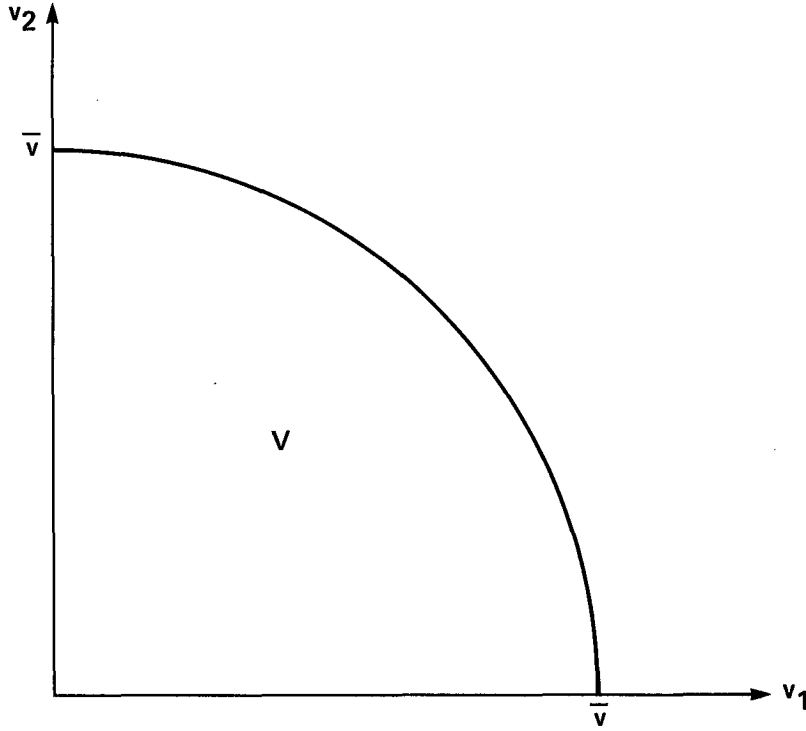

Figure 9.- Circular control constraint.

$$J_u = J_v = \int_0^{\bar{t}} dt . \quad (60)$$

As before, inspection of (22) and (27) shows that v can always force termination (i.e., $\dot{x}_2(\bar{t}) < 0$) and is therefore always capable of winning; whereas from (21), (26), and (59), u can win only if

$$\bar{u} > \bar{v} . \quad (61)$$

We begin by investigating the game with this condition holding and first consider u 's winning game; that is, u minimizes and v maximizes (60) subject to (21), (22), (24), (35), (36), and (59). The Hamiltonian is

$$H = 1 + \lambda_1(v_1 - u) - \lambda_2 v_2 + \mu(\bar{v}^2 - v_1^2 - v_2^2) , \quad (62)$$

where the (ordinary) multiplier μ satisfies

$$\left\{ \begin{array}{ll} \mu = 0 & \text{if } v_1^2 + v_2^2 < \bar{v}^2 \\ \mu \geq 0 & \text{if } v_1^2 + v_2^2 = \bar{v}^2 \end{array} \right\} \quad (63)$$

and λ_1 and λ_2 are constants. The optimal controls for v must satisfy

$$\left\{ \begin{array}{l} \frac{\partial H}{\partial v_1} = \lambda_1 - 2\mu v_1 = 0 \\ \frac{\partial H}{\partial v_2} = -\lambda_2 - 2\mu v_2 = 0 \end{array} \right\} . \quad (64)$$

Since $\mu = 0$ violates the condition $H = 0$, required for optimal controls, (63) implies that v 's optimal controls satisfy

$$v_1^2 + v_2^2 = \bar{v}^2 \quad (65)$$

Further, $H = 0$ and conditions (64) imply that

$$\lambda_1 > 0 \quad \text{and} \quad \lambda_2 \leq 0 \quad (66)$$

so that

$$u^* = \bar{u} . \quad (67)$$

If (36) is satisfied with strict inequality at $t = \bar{t}$, the transversality conditions give $\lambda_2 = 0$, and from (64) and (65), for this case,

$$v_1^* = \bar{v}, \quad v_2^* = 0 . \quad (68)$$

To determine the boundary of u 's winning region, note that v desires to choose controls (subject to (65)) to make this region as small as possible. Assuming constant controls and using (65), (21) and (22) may be integrated to give

$$\epsilon_1 = x_1^0 + (v_1 - \bar{u})\bar{t} \quad (69)$$

and

$$\bar{x}_2 = x_2^0 - (\bar{v}^2 - v_1^2)^{1/2}\bar{t} . \quad (70)$$

Evaluating (36) at $t = \bar{t}$ and using (69) and (70) gives

$$x_2^0 - \epsilon_2 - \delta \geq (\bar{v}^2 - v_1^2)^{1/2} \frac{x_1^0 - \epsilon_1}{\bar{u} - v_1} . \quad (71)$$

Therefore, u 's winning region will be smallest when $v_1 = \gamma^2 \bar{u}$, where $\gamma = \bar{v}/\bar{u}$; putting this value in (71) gives the specification of region $\Phi_u(\delta)$ as

$$x_2^0 - \epsilon_2 - \delta \geq (x_1^0 - \epsilon_1)/(1/\gamma^2 - 1)^{1/2} . \quad (72)$$

The optimal strategies in this region are (67) and (68).

Next, consider v's winning δ -game for (61) holding; now u maximizes and v minimizes (60), subject to (59). The Hamiltonian is (62) as before, but now $\mu \leq 0$ in (63). Proceeding as before, if (46) is satisfied with strict inequality $\lambda_1 = 0$, then v's optimal controls are

$$v_1^* = 0, \quad v_2^* = \bar{v} \quad (73)$$

and u's control is indeterminate. For (46) satisfied with equality at $t = \bar{t}$, u's optimal control is given by (67) and v's optimal controls are constants satisfying (65). Integrating (21) and (22) with these controls gives

$$\left\{ \begin{array}{l} \bar{t} = (x_2^0 - \epsilon_2)/(\bar{v}^2 - v_1^2)^{1/2} \\ \epsilon_1 + \delta = (v_1 - \bar{u})(x_2^0 - \epsilon_2)/(\bar{v}^2 - v_1^2)^{1/2} + x_1^0 \end{array} \right\} . \quad (74)$$

Solving the latter equation for v_1 ,

$$v_1 = \bar{u} \frac{1 - \eta[\gamma^2(1 + \eta^2) - 1]^{1/2}}{1 + \eta^2} \quad (75)$$

where

$$\eta = \frac{x_1^0 - \epsilon_1 - \delta}{x_2^0 - \epsilon_2} . \quad (76)$$

This control will be used in the region in which (75) will have real solutions satisfying (65); that is,

$$(1/\gamma^2 - 1)^{1/2} \leq \eta \leq 1/\gamma . \quad (77)$$

Note that the controls corresponding to the lower and upper bounds in (77) are $v_1 = \gamma^2 \bar{u}$ and $v_1 = 0$, respectively.

We have now determined the regions and optimal controls for the case $\Phi_u^{(1)}$. In $\Phi_u(\delta)$, defined by (72), the optimal controls are (67) and (68). In $\Phi_v^{(1)}(\delta)$, defined by

$$\eta > 1/\gamma , \quad (78)$$

the controls are (73) with u indeterminate. In $\Phi_v^{(2)}(\delta)$, defined by (77), the optimal controls are given by (65), (67), and (75).

To resolve the combat in the remaining region, that is, the region which satisfies neither (72) nor $(1/\gamma^2 - 1)^{1/2} \leq \eta$, we proceed as in the linear constraint case. Initial states not satisfying these inequalities for all positive δ , no matter how small, lie on a line of slope $(1/\gamma^2 - 1)^{-1/2}$ passing through (ϵ_1, ϵ_2) .

This line, the dashed line in figure 10(a), is a locus of joint capture initial states for which the unique controls are (67), $v_1^* = \gamma \bar{u}$, and $v_2^* = \gamma \bar{u}(1 - \gamma^2)^{1/2}$. The various regions and example optimal trajectories are shown in figure 10(a).

$$\textcircled{1} \quad x_2^0 = \frac{x_1^0 - \epsilon_1}{\sqrt{1/\gamma^2 - 1}} + \epsilon_2 + \delta$$

$$\textcircled{2} \quad x_2^0 = \frac{x_1^0 - \epsilon_1 - \delta}{\sqrt{1/\gamma^2 - 1}} + \epsilon_2$$

$$\textcircled{3} \quad x_2^0 = \gamma(x_1^0 - \epsilon_1 - \delta) + \epsilon_2$$

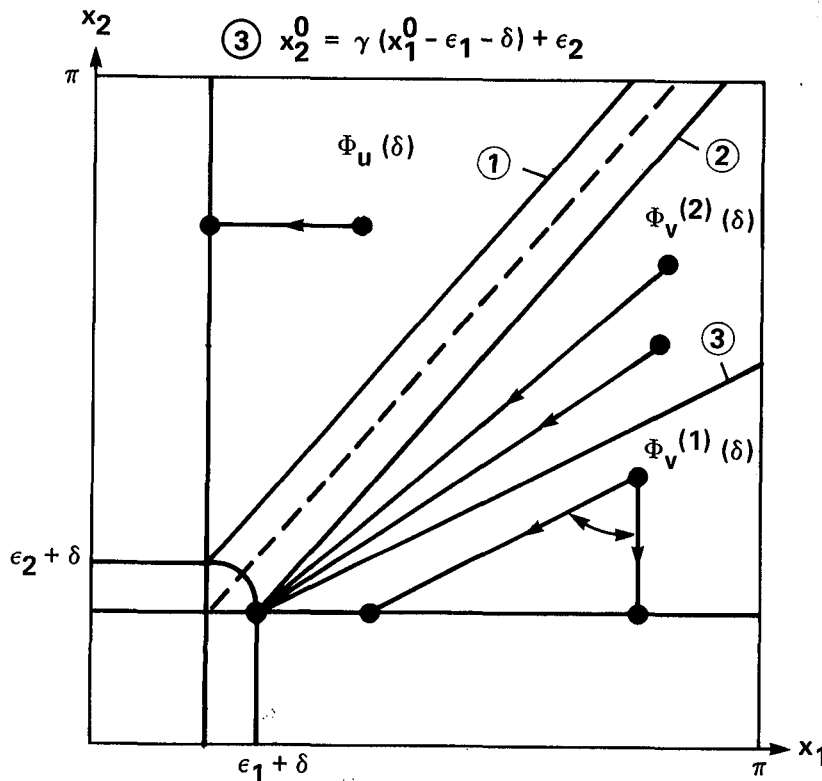

(a) $\gamma < 1$.

Figure 10.- Regions and optimal trajectories in the playing space; turret game with circular control constraint and time-optimality.

The cases $\bar{u} = \bar{v}$ and $\bar{u} < \bar{v}$ may be easily inferred from the results for the case (61). As $\gamma \rightarrow 1$ from below, the slopes of the boundary lines labeled (1) and (2) in figure 10(a) become infinite. Therefore, $\Phi_u(\delta)$ vanishes and the upper boundary of $\Phi_v(\delta)$ now depends on the prespecified value of T^* . To find this boundary, we integrate (21) and (22) using (65) and (67) backward from $(\epsilon_1 + \delta, \epsilon_2)$ over an interval of time $T^* - \delta$. The result is that initial conditions in region $\Phi_v^{(2)}(\delta)$ must satisfy

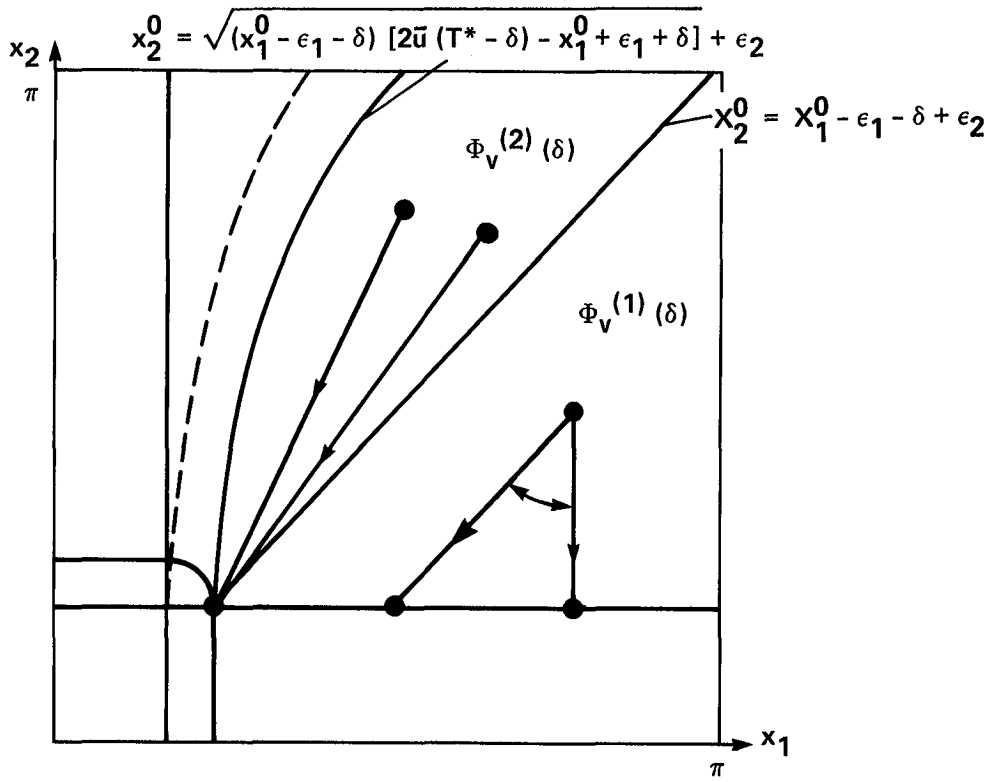

(b) $\gamma = 1$.

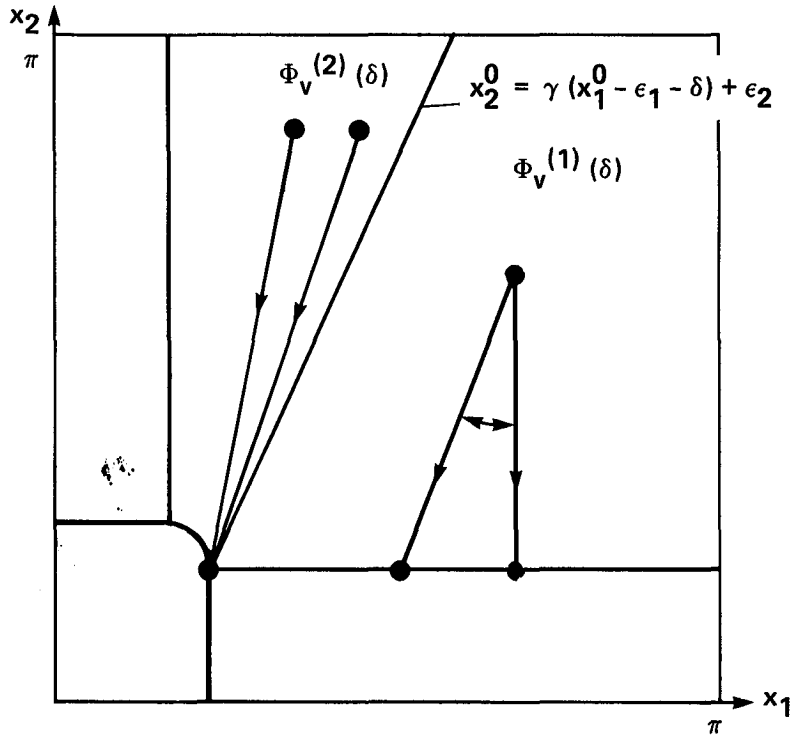

(c) $\gamma > 1$.

Figure 10.- Concluded.

$$(x_2^0 - \epsilon_2)^2 \leq (x_1^0 - \epsilon_1 - \delta)[2\bar{u}(T^* - \delta) - x_1^0 + \epsilon_1 + \delta]. \quad (79)$$

Regions $\Phi_v^{(1)}(\delta)$ and $\Phi_v^{(2)}(\delta)$ are shown in figure 10(b), and the controls in these regions are as previously but with $\gamma = 1$.

From initial states in the region complementary to (79), neither player can win the δ -game. Letting δ become vanishingly small, the boundary line associated with (79) becomes the dashed line shown in figure 10(b). Points below this line are in $\Phi_v^{(2)}(\hat{\delta})$ for some $\hat{\delta} > 0$, and from points above this line both players can secure a draw. As before, draw strategies are not unique. From initial states on the boundary line itself, v has the option of draw or joint capture at $t = T^*$; by the preference order for ordinary combat, he chooses draw.

Finally, for $\bar{u} < \bar{v}$ (fig. 10(c)), $\Phi_v(\delta)$ is the entire playing space, again composed of regions $\Phi_v^{(1)}(\delta)$ and $\Phi_v^{(2)}(\delta)$.

6. DISCUSSION

Although the turret game is a very simple and idealized problem, analysis of this game has revealed a rich variety of combat phenomena. First, note that the solution to this game exhibits many features commonly found in differential games, such as the existence of barriers and "singular" surfaces. An example of a singular surface is given by (58) with the inequality being replaced by equality; this is a singular surface of type $(p, u, -)$ in Isaacs' terminology (ref. 2).

The optimal strategies also exhibit features common in differential game solutions. In most regions of the state/parameter space, the optimal controls of both players are unique and constant. There are regions, however, in which the controls are nonunique ($\Phi_u^{(3)}(\delta)$ in fig. 7(a), and $\Phi_v^{(2)}(\delta)$ and $\Phi_v^{(3)}(\delta)$ in fig. 7(c)). We note that in many cases the optimal strategies are obvious; for example, from initial conditions in the region $\Phi_v^{(1)}(\delta)$ in figure 7, player v can capture u (before being himself captured) by simply "standing" and turning his turret at the maximum rate.

The turret game solution, however, shows that combat problems have features not encountered in games of survival and pursuit-evasion. One of these features is the existence of a manifold on which both players are locked into mutual destruction at the earliest possible time, in the sense that any deviation from this policy by one of the players will result in his unilateral capture by the other. This situation is mentioned in reference 7, and has been found to occur also in nonoptimal air combat simulations (ref. 27). Another feature is a manifold on which one of the players has the unilateral choice between a draw and mutual destruction at a time of his choosing.

The idea of δ -combat games, introduced to solve technical problems concerned with closure properties of the target sets, also has important practical

implications. In the turret game, δ is closest that the winning player is allowed to approach his opponent's target at termination. Thus, the winning player can choose δ to specify to what degree he is willing to accept the risk of his own capture.

Because of past emphasis on pursuit-evasion problems, it is of interest to examine the turret game from a pursuit-evasion standpoint. First consider the (time-optimal) pursuit-evasion game with u as the pursuer and v as the evader (u/v) subject to (24) and (28). The necessary conditions give the optimal strategies as $u^* = \bar{u}$, $v_1^* = \bar{v}_1$, and $v_2^* = 0$ for $\bar{v}_1 \leq \bar{u}$, and capture occurs if $\bar{v}_1 < \bar{u}$. For v/u , the optimal controls are $v_1^* = 0$, $v_2^* = \bar{v}_2$, and u^* undefined, and capture always occurs.

Now suppose we (naively) attempt to construct the combat results from the pursuit-evasion results by assuming that whichever pursuit-evasion game ends in the least time will be the one played. Then, for $\bar{v}_1 \geq \bar{u}$, the v/u game will be played everywhere. For $\bar{v}_1 < \bar{u}$, the times of the two games must be compared. Integrating (21) and (22) with the two sets of controls shows that the u/v game will be played if

$$\frac{x_2^0 - \epsilon_2}{x_1^0 - \epsilon_1} > \frac{\gamma_2}{1 - \gamma_1}, \quad (80)$$

and conversely for the v/u game. These results are shown in the playing space in figure 11 for δ vanishingly small. Note that the slope of the boundary line (80) is greater than the slope of the boundary lines (47) and (48).

Comparing figures 8 and 11, we see that in the regions (*) on figure 11 the two analyses give the same solutions, but that in the other regions the solutions are dramatically different. In all these other regions, the pursuit-evasion solution indicates that v will win, v 's optimal strategy is $(0, \bar{v}_2)$, and u 's strategy is immaterial. In region (1) on figure 11(a), however, the combat game results show that if u plays \bar{u} , then u will win. Moreover, u will win in minimum time, if v persists in playing his pursuit-evasion-derived strategy. In (2) on figure 11(b), the combat results show that the best v can achieve is a draw, and that he must play $(\bar{v}_1, 0)$ to do this; if v plays his pursuit-evasion strategy, u will win. And in (3) on figure 11(c), v can in fact win but he must recognize and avoid u 's target to do so.

Thus from v 's standpoint, the pursuit-evasion results frequently tell him he can win when he cannot. Moreover, use of the pursuit-evasion strategies frequently will cause v to be captured when capture is avoidable, or lead him to be captured in minimum time when capture cannot be avoided. From u 's standpoint, the pursuit-evasion results frequently tell him that he will be captured and that his strategy selection is of no consequence, when in fact he has winning or draw strategies. Thus, the serious fallacy of using pursuit-evasion methods to "solve" combat problems (i.e., differential games between opponents with offensive capabilities and offensive objectives) is clear.

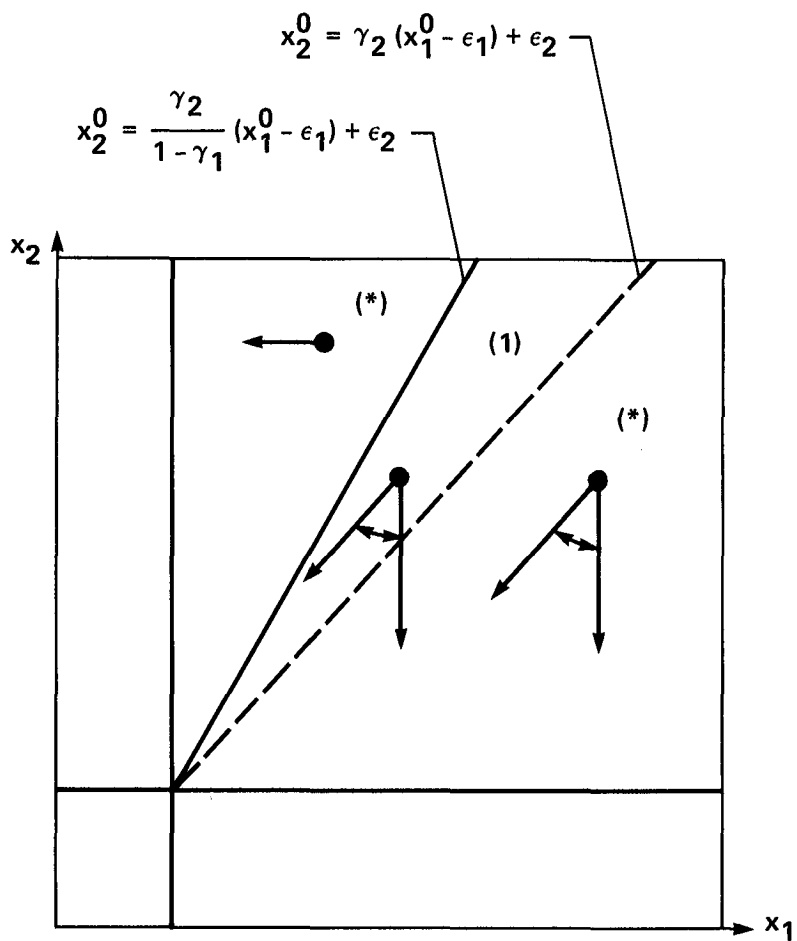

(a) $\gamma_1 < 1$.

Figure 11.- Results for turret game based on minimum-time pursuit-evasion games.

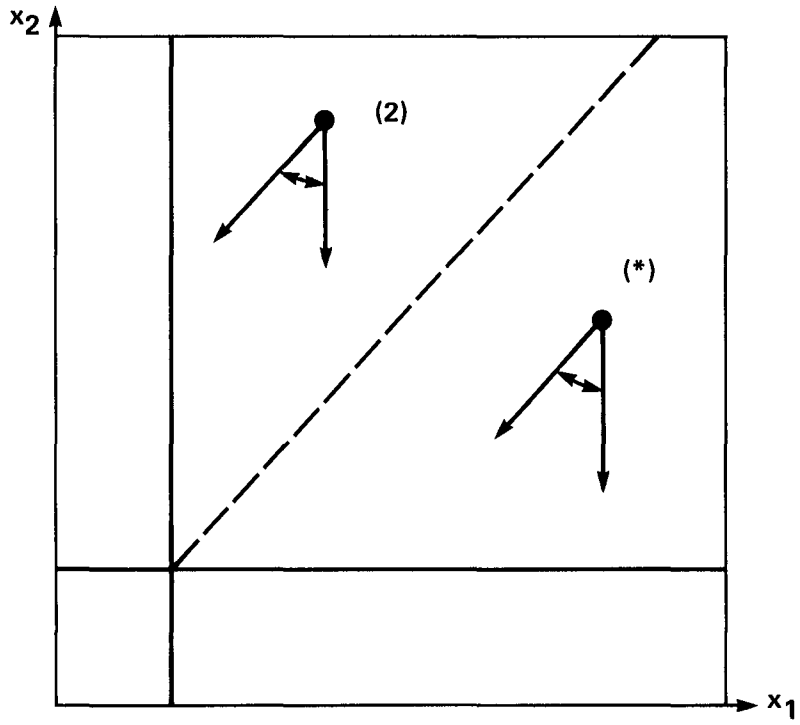

(b) $\gamma_1 = 1$.

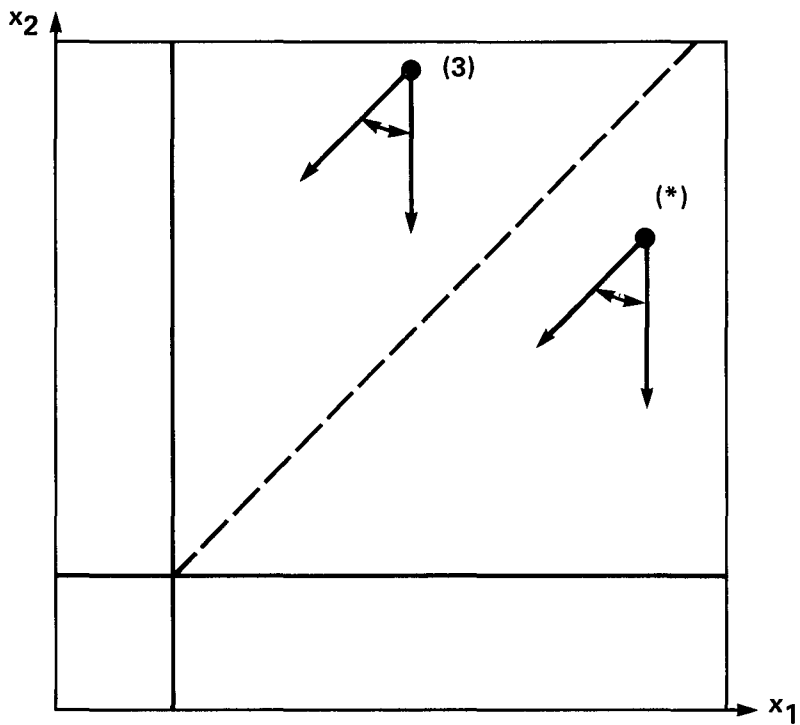

(c) $\gamma_1 > 1$.

Figure 11.- Concluded.

As a final point in our discussion, we wish to reemphasize the role of threat for optimal strategy selection in suitably formulated combat games. We have clearly seen above that both players combine offensive and defensive behavior in their optimal strategies. The winning player, during his offense, takes defensive measures to avoid being captured himself. At the same time, the losing player, usually thought of as defensive, applies a threat to the winner. That is, he also implements his offensive capability in order to prevent his opponent from using the most damaging strategies (in terms of the formulated game's cost). In a properly formulated combat game, just as in actual combat, both players combine a suitable blend of offensive and defensive maneuvering.

Ames Research Center

National Aeronautics and Space Administration

Moffett Field, California 94035, December 20, 1984

REFERENCES

1. Friedman, A.: Differential Games. Wiley, Interscience, New York, 1971.
2. Isaacs, R.: Differential Games. Wiley, New York, 1965.
3. Hajek, O.: Pursuit Games. Academic Press, New York, 1975.
4. Roxin, E. O.; Liu, P.; and Sternberg, R. L.: Differential Games and Control Theory. Marcel Dekker, New York, vol. 1, 1974; vol. 2, 1977.
5. Leondes, C. T., ed.: Control and Dynamic Systems--Advances in Theory and Applications, vol. 17. Academic Press, New York, 1981.
6. Baron, S.; Chu, K.-C.; Ho, Y. C.; and Kleinman, D. L.: A New Approach to Aerial Combat Games. NASA CR-1626, 1970.
7. Basar, T.; and Olsder, G. J.: Dynamic Noncooperative Game Theory. Academic Press, New York, 1982.
8. Breakwell, J. V.; and Merz, A. W.: Toward a Complete Solution of the Homicidal Chauffeur Game. Proceedings of the First International Conference on the Theory and Applications of Differential Games, U. of Massachusetts, Sept. 1969.
9. Merz, A. W.: The Homicidal Chauffeur. AIAA J., vol. 12, 1974, p. 259-260.
10. Merz, A. W.: The Game of Two Identical Cars. Multicriteria Decision Making and Differential Games, George Leitmann, ed., Plenum Press, New York, 1976, pp. 421-442.
11. Breakwell, J. V.; and Merz, A. W.: Minimum Required Capture Radius in a Coplanar Model of the Aerial Combat Problem. AIAA J., vol. 15, Aug. 1977, pp. 1089-1094.
12. Merz, A. W.: The Game of Two Identical Cars. J. of Optimization Theory and Applications, vol. 9, May 1972, pp. 324-343.
13. Olsder, G. J.; and Breakwell, J. V.: Role Determination in an Aerial Dogfight. Int. J. of Game Theory, vol. 3, 1974, pp. 47-66.
14. Pachter, M.; and Getz, W. M.: The Geometry of the Barrier in the Game of Two Cars. Optimal Control Applications and Methods, vol. 1, Jan.-Mar. 1980, pp. 103-118.

15. Kelley, H. J.; and Lefton, L.: Estimation of Weapon-Radius vs Maneuverability Tradeoff for Air-to-Air Combat. AIAA J., vol. 15, Feb. 1977, pp. 145-148.
16. Ho, Y. C.: Differential Games, Dynamic Optimization and Generalized Control Theory. J. of Optimization Theory and Applications, vol. 6, Sept. 1970, pp. 179-209.
17. Rajan, N.; Prasad, U. R.; and Rao, N. J.: Pursuit-Evasion of Two Aircraft in a Horizontal Plane. J. Guidance Control, vol. 3, May-June 1980, pp. 261-267.
18. Jarmark, B. S. A.; Merz, A. W.; and Breakwell, J. V.: The Variable-Speed Tail-Chase Aerial Combat Problem. J. Guidance Control, vol. 4, May-June 1981, pp. 323-328.
19. Prasad, U. R.; Rajan, N.; and Rao, N. J.: Planar Pursuit-Evasion with Variable Speeds. I. Extremal Trajectory Maps. II. Barrier Sections. J. of Optimization Theory and Applications, vol. 33, March 1981, pp. 401-432.
20. Peng, W. Y.; and Vincent, T. L.: Some Aspects of Aerial Combat. AIAA J., vol. 13, Jan. 1975, pp. 7-11.
21. Kelley, H. J.; and Lefton, L.: Differential Turns. AIAA J., vol. 11, June 1973, pp. 858-861.
22. Getz, W. M.; and Pachter, M.: Two-Target Pursuit-Evasion Differential Games in the Plane. J. of Optimization Theory and Applications, vol. 34, July 1981, pp. 383-403.
23. Getz, W. M.; and Pachter, M.: Capturability in a Two-Target Game of Two Cars. J. Guidance Control, vol. 4, Jan.-Feb. 1981, pp. 15-21.
24. Blaquiere, A.; Gerard, F.; and Leitmann, G.: Quantitative and Qualitative Games. Academic Press, New York, 1969.
25. Getz, W. M.; and Leitmann, G.: Qualitative Differential Games with Two Targets. J. Math. Analysis and Applications, vol. 68, Apr. 1979, pp. 421-430.
26. Davidowitz, A.; and Shinar, J.: An Eccentric Two-Target Differential Game Model for Qualitative Air-to-Air Combat Analysis. AIAA Paper 83-2122, Gatlinburg, Tenn., Aug. 1983.
27. Herbst, W. B.: Dynamics of Air Combat. J. of Aircraft, vol. 20, July 1983, pp. 594-598.



1. Report No. NASA TP-2487		2. Government Accession No.		3. Recipient's Catalog No.	
4. Title and Subtitle A FORMULATION AND ANALYSIS OF COMBAT GAMES				5. Report Date June 1985	
				6. Performing Organization Code	
7. Author(s) Michael Heymann (Technion-Israel Institute of Technology, Haifa, Israel), Mark D. Ardema, and Narayanaswami Rajan (Aero. & Astro. Dept., Stanford Univ., Calif.)				8. Performing Organization Report No. 85022	
				10. Work Unit No.	
9. Performing Organization Name and Address Ames Research Center Moffett Field, CA 94035				11. Contract or Grant No.	
				13. Type of Report and Period Covered Technical Paper	
12. Sponsoring Agency Name and Address National Aeronautics and Space Administration Washington, DC 20546				14. Sponsoring Agency Code 505-34-11	
15. Supplementary Notes Point of contact: Dr. Mark Ardema, M/S 210-9, Ames Research Center, Moffett Field, CA 94035, (415)694-5450 or FTS 464-5450					
16. Abstract <p>Combat is formulated as a dynamical encounter between two opponents, each of whom has offensive capabilities and objectives. With each opponent is associated a target in the event space in which he endeavors to terminate the combat, thereby winning. If the combat terminates in both target sets simultaneously or in neither, a joint capture or a draw, respectively, is said to occur. Resolution of the encounter is formulated as a combat game; namely, as a pair of competing event-constrained differential games. If exactly one of the players can win, the optimal strategies are determined from a resulting constrained zero-sum differential game. Otherwise the optimal strategies are computed from a resulting non-zero-sum game. Since optimal combat strategies frequently may not exist, approximate or δ-combat games are also formulated leading to approximate or δ-optimal strategies. To illustrate combat games, an example, called the turret game, is considered. This game may be thought of as a highly simplified model of air combat, yet it is sufficiently complex to exhibit a rich variety of combat behavior, much of which is not found in pursuit-evasion games.</p>					
17. Key Words (Suggested by Author(s)) Differential games Air combat Combat problems Turret game Two-target games			18. Distribution Statement Unclassified - Unlimited Subject Category 08		
19. Security Classif. (of this report) Unclassified		20. Security Classif. (of this page) Unclassified		21. No. of Pages 41	22. Price A03



LANGLEY RESEARCH CENTER



3 1176 00520 3774

BULK RATE

POSTAGE & FEES PAID

NASA Washington, DC

Permit No. G-27

**National Aeronautics and
Space Administration**

**Washington, D.C.
20546**

Official Business

Penalty for Private Use, \$300



**POSTMASTER: If Undeliverable (Section 158
Postal Manual) Do Not Return**

