

A METHOD TO IMPROVE OBSERVATIONS OF GAMMA RAY SOURCES NEAR 10^{15} eV

Sommers, P. and Elbert, J.W.

Physics Department, University of Utah, Salt Lake City, UT 84112 USA

ABSTRACT

Now that sources of gamma rays near 10^{15} eV have been identified, there is a need for "telescopes" which can study in detail the high energy gamma ray emissions from these sources. We analyze the capabilities of a Cerenkov detector which can track a source at large zenith angle (small elevation angle). Because the observed showers must then develop far from the detector, the effective detection area is very large. During a single half-hour hot phase of Cygnus X-3, for example, it may be possible to detect 45 signal showers compared with 10 background showers. Time structure within the hot phase may then be discernible. The precise capabilities of the detector depend on its mirror size, angular acceptance, electronic speed, coincidence properties, etc. We present calculations for one feasible design using mirrors of an improved Fly's Eye type.

For observing distant air showers, the effective detection area of a Cerenkov detector is determined by its angular aperture according to the formula

$$A = \pi(D \cdot \tan\phi)^2 \quad (1)$$

where ϕ is the 1/2-aperture angle and D is the distance from the detector to the position of Cerenkov light emission. The relevant geometry is indicated in figure 1. A very large detection area can be attained at large zenith angle because the large atmospheric slant depth causes the showers to develop far from the detector. Relatively high primary energies are required in order to yield a detectable photon density at the detector. Our calculations concern showers of 1 PeV ($=10^{15}$ eV) or greater energy. Table 1 shows how the detection area increases with zenith angle for $\phi = 1.7$ degrees. The distance D is the distance from a slant depth of 600 gm/cm² (depth of maximum for PeV showers) to a vertical depth of 862 gm/cm² (corresponding to the Fly's Eye altitude). The distances are computed using the U.S. Standard Atmosphere and incorporating the (small) effects of the earth's curvature.¹ For quick calculations it is helpful to have an analytic formula which yields approximately correct values. If atmospheric depth is given by $x = 1030 \exp(-h/7)$ gm/cm², with h the vertical altitude above sea level in km, then one gets

$$D \approx \frac{1}{\cos\theta} \left\{ -7 \ln \left(\frac{600 \cos\theta}{1030} \right) - h_0 \right\} \quad (2)$$

where θ is the zenith angle and h_0 is the detector's altitude in km above sea level.

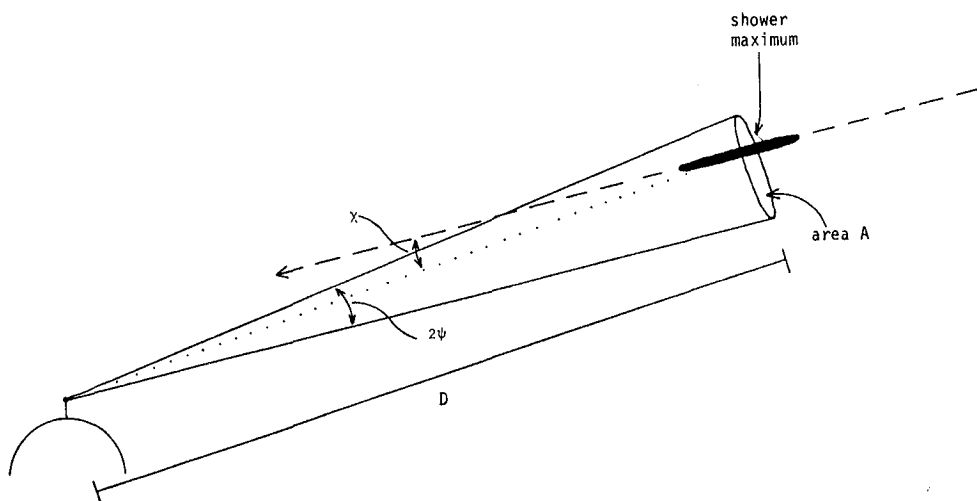

Figure 1

Using numerical simulations of Cerenkov light emission² and atmospheric propagation,³ we have studied the dependence of the detector amplitude on zenith angle and the viewing angle χ (between the shower core and the detector's line of sight to shower maximum). For mirrors of 96 inches diameter (as proposed for an improved Fly's Eye), with 70% reflectivity and for phototube cathodes of the S-11 type with extended UV response, we find the number of photoelectrons to be given approximately by

$$PE \approx 1.3 \times 10^7 E D^{-2.5} \times \begin{cases} e^{\chi_c - \chi} & (\chi > \chi_c) \\ 1 & (\chi < \chi_c) \end{cases} \quad (3)$$

where E is the primary γ -ray energy in PeV, D is the distance as in table 1, χ is measured in degrees, and χ_c is a zenith-angle-dependent critical angle (see table 1). The PE values in table 1 are obtained from this formula with $\chi < \chi_c$. A factor of 1.5 should be applied to the right side of equation 3 for an approximate conversion to photons/meter². The formula applies to γ -ray showers; hadronic showers yield an amplitude smaller by a factor of 0.73.

Table 1

Zenith Angle (deg)	D (km)	A [$\phi=1.7^\circ$] (km ²)	PE (photoelectrons)	χ_c (deg)
60	16	.71	13000	.8
65	21	1.2	6400	.8
70	30	2.5	2600	.7
75	46	5.9	910	.6
80	84	20.	200	.5

For a fixed amplitude threshold and fixed zenith angle, there is a maximum viewing angle at which a shower can be detected. Suppose the threshold is set at the PE value given in table 1 for a 1 PeV shower. The maximum viewing angle for γ -ray showers is then (from eqn 3)

$$\chi_{\max}^{\gamma}(E) = \begin{cases} \chi_c + \ln E & E > 1 \\ 0 & E < 1. \end{cases} \quad (4)$$

Since this angle is energy dependent, the 1/2-aperture ϕ which optimizes the signal-to-noise ratio depends on the source's spectral index. (In principle, the signal's dependence on ϕ can be used to determine the spectral index.) Table 2 presents some expected results for Cyg X-3 based on the Kiel data (differential spectral index of 2.1 with a cutoff at 20 PeV). The signal rate is computed by

$$\text{signal rate} = \int_1^{20} \frac{dS}{dE} \cdot \text{area}(E) dE \quad (5)$$

where $\frac{dS}{dE}$ is the differential flux from Cyg X-3 (taken as a typical hot phase flux of 10 times the time-averaged flux). The $\text{area}(E)$ is given by equation (1) with ϕ replaced by $\chi_{\max}^{\gamma}(E)$ if $\chi_{\max}^{\gamma}(E)$ is less than ϕ . For the background rate we use

$$\text{background rate} = A \int_{1/.73}^{\infty} \frac{dN}{dE} \Omega(E) dE. \quad (6)$$

Here A is the area from table 1, $\frac{dN}{dE}$ is the cosmic ray flux (with the spectral index taken to be 2.8) and $\Omega(E) = 2\pi(1 - \cos \chi_{\max}^H(E))$, where the maximum viewing angle for hadronic showers is $\chi_{\max}^H(E) = \chi_{\max}^{\gamma}(.73E)$. The last 3 columns of table 2 give the numbers of showers and signal-to-noise ratio from a single Cyg X-3 observation for 1720 seconds (.1 period).

Because of the strong dependence of rates on zenith angle in this range, careful monitoring of background rates is essential for identification of the signal from a source. Moreover, it may be necessary to operate two or more separated detectors in coincidence in order to reject spurious triggers from stray muons and background light fluctuations. Nevertheless, it appears feasible to detect a source like Cyg X-3 in a single short observation and to see some detail in the light curve. If a neutron star rotation period is modulating the PeV emissions from Cyg X-3, that period should be discoverable using this method.

TABLE 2

Zenith Angle (deg)	Optimal ϕ (deg)	Signal rate (s^{-1})	Background rate (s^{-1})	Signal/noise coefficient ($s^{-1/2}$)	Signal at 1720s (showers)	Background at 1720s (showers)	Signal/Noise at 1720s
60	1.75	.0082	.0019	.19	14	3.2	7.8
65	1.75	.014	.0033	.25	24	5.6	10
70	1.7	.026	.0056	.34	44	9.7	14
75	1.65	.054	.011	.51	92	19	21
80	1.6	.16	.031	.90	270	53	37

Acknowledgement.

This research was supported by the United States National Science Foundation under grant number PHY8415294.

Notes.

1. Based on tables in "An Analysis of the Nuclear Interaction of High Energy Cosmic Rays," Osborne, J.L., Ph.D. thesis, University of Durham (1966).

2. Based on shower properties given in Hillas, A.M., J. Phys. G 8, 1461 (1982).

3. Based on tables in Elterman, L. & Toolin, R.B., Handbook of Geophysics and Space Environments, (Bedford, Mass.: U.S.A.F. Cambridge Research Laboratories), Chapter 7 (1965).