

PROPORTIONAL DRIFT TUBES FOR LARGE AREA MUON DETECTORS

C. Cho, S. Higashi, N. Hiraoka, A. Maruyama, T. Okusawa
T. Sato, T. Suwada, T. Takahashi and H. Umeda

Department of Physics, Osaka City University
Sugimoto, Sumiyoshi-ku, Osaka, Japan

ABSTRACT

A proportional drift chamber which consists of eight rectangular drift tubes with cross section of 10 cm x 5 cm, a sense wire of 100 $\mu\phi$ gold-plated tungsten wire and the length of 6 m, is constructed and tested using cosmic ray muons. Spatial resolution (rms) is between 0.5 and 1 mm over drift space of 50 mm, depending on incident angle and distance from sense wire.

1. INTRODUCTION

The large proportional drift chamber have been constructed for muon identification in the TOPAZ experiment at KEK to study e^+e^- interactions (1). A chamber contain eight rectangular drift tubes with cross section of 10 cm x 5 cm, length of 6 m and a sense wire for each cell (Fig. 1). Two adjacent planes of staggered tubes help to solve the left-right-ambiguity. The chamber with large area, very simple structure and good space resolution is also very useful to study muons in cosmic ray experiments, specially to measure the direction of muons for multiple muon study and spectrograph. In this paper, we will describe the chamber design, and cosmic ray test on the three muon chambers aligned vertically, filled with mixture of Ar + 10% CH₄. Reconstructions of tracks of the cosmic ray in the chamber determine the drift distance from sense wire as a function of the electron's drift time,

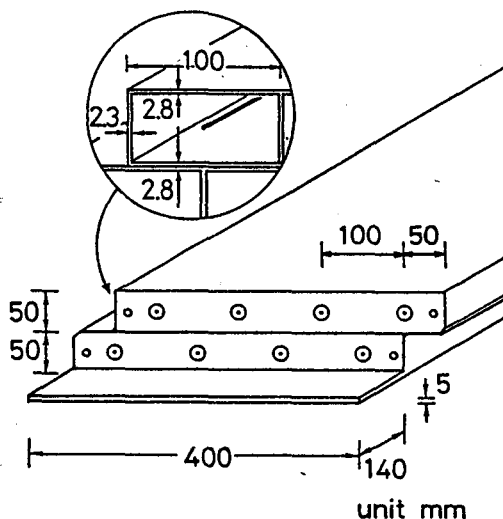

Fig. 1
Sketch of the proportional drift tube chamber.

the spatial resolution and the chamber efficiency.

2. CONSTRUCTION

A chamber consists of eight rectangular drift tubes with cross section of 10 cm x 5 cm and the length of 6 m. A chamber is made out of two four-cell structures which are extruded separately from 6063-T5 aluminium and welded together. The ends of the chamber are notched to allow serial gas flow between cells. Aluminium end caps are welded onto both ends of the four-cell structures to seal gas, which also used to support sense wires. Aluminium plates are welded onto both ends of the lower four-cell structure to mount the chamber on the apparatus. A maximum sagitta at the center of chamber is less than 3 mm, a maximum lateral twist about the wire axis less than 3° and a surface flatness for 400 mm wide less than 1.6 mm. The extrusion is cleaned with 10% sodium hydroxide to take off oil and nap on the aluminium surface. Each cell has a sense wire of gold-plated tungsten of 100 μm in diameter to get high electric field at the position far from the wire. The wire is soldered to copper pins in the center of Delrin plugs under the tension of 850 grams. Lids are attached to both ends to provide mechanical protection for the wire and electronics. Chambers can maintain a vacuum pressure of less than 0.1 Torr, which is the limit of the pump used.

High voltage and preamplifier/discriminator PC boards are mounted on the chamber. The wire is connected to the high voltage supply through a 10 Megohm register, and the preamplifier through a 500 pF coupling capacitor.

3. RESULTS

Fig. 2 shows a set-up of the chamber and read out system to measure the drift time as a function of a drift space,

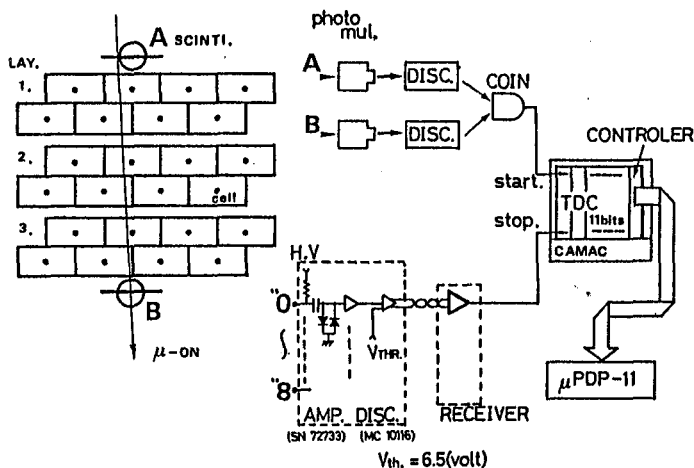

Fig. 2
Schematic view of the set-up for measuring the space resolution of the drift tubes with incident cosmic rays.

the spatial resolution and the detection efficiency. The set-up consists of three chambers and two scintillation counters with 10 cm width which are used to select cosmic ray muons and to generate start pulse for TDC. The drift times are digitized by 11 bit CAMAC TDC's with 2ns bins and read out to micro PDP-11. The data are taken for track angles 0° , 28° and 45° with gas flow of 100 cc/min, high voltage of 3.1 KV and threshold of 500 μV . The analysis to get spatial resolution is as follows. Data on time, about 1×10^4 events for a track angle are converted to drift distance from the wire using a time-distance relation which is assumed at first. Assuming the wire positions, the circular space contours are fitted with a straight line of a track using the method of least squares, which gives time new distance on the straight line. The mean of the

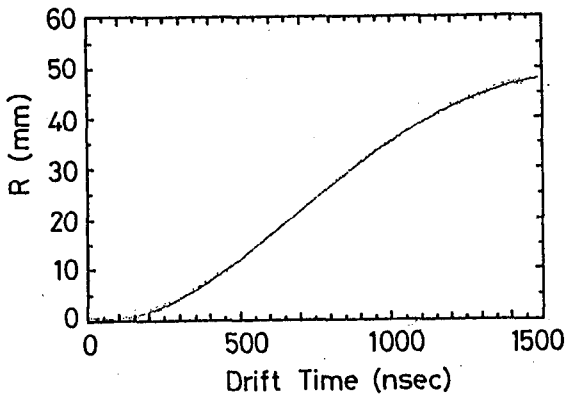

Fig. 3
Distance from the sense wire versus measured drift time for track angle 0° .

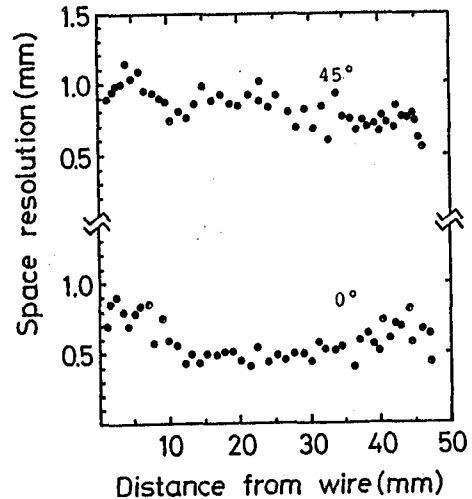

Fig. 4
Spatial resolution (rms) VS distance from wire for track angles 0° , 45° .

deviation from the straight line for each wire changes the wire position. By calculating the mean of the time-distance distribution, an empirical time-distance relation is obtained, which is used for next straight line fit. These calculations are continued until the width of the experimental time-distance distribution is minimized.

Fig. 3 shows a scatter plot of the drift time VS the distance of the track from the sense wire; time-distance distribution for track angle 0° . At larger track angles the

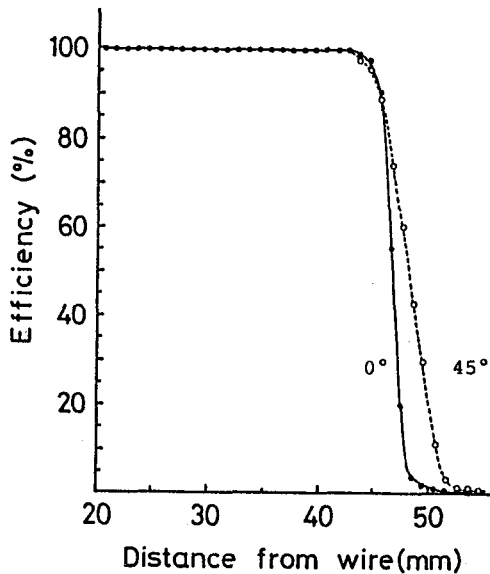

Fig. 5
Detection efficiencies for
cosmic rays in the drift
tubes for track angles 0° ,
 45° .

time-distance distribution is almost the same. Fig. 4 shows the spatial resolutions (rms) VS the distance at 0° and 45° , which are obtained from the time-distance distributions (Fig. 3). The resolution is 0.5 mm at the center and about 0.8 mm at near to and far away from the wire for track angle 0° , but gets worse at large track angle, ~ 1 mm at 45° . Fig. 5 shows the single wire efficiencies VS position distribution with a maximum collection time of $2 \mu\text{s}$ at 0° and 45° . The efficiency is greater than 99.97% within 43 mm but drops off rapidly near the ends.

4. CONCLUSION

Large area rectangular drift tube chamber with drift space of 5 cm are constructed and tested. The spatial resolution (rms) is better than 1 mm, and the efficiency for detecting the passage of a particle is greater than 99.9%. These characteristics are adequate for the purpose of a large muon detector in cosmic ray experiments.

REFERENCE

1. R. Hayano et al (1983) TRISTAN PROPOSAL, TRISTAN-EXP-002

ACKNOWLEDGEMENT

We wish to thank all members of TOPAZ-group, in particular, T. Kamae, S. Iwata and Y. Watanabe for their encouragement.