

## MODULAR DETECTOR FOR DEEP UNDERWATER REGISTRATION OF MUONS AND MUON GROUPS

A.I.Demianov, L.I.Sarycheva, N.B.Sinyov, I.N.Vardanyan,  
A.A.Yershov

Institute of Nuclear Physics, Moscow State University,  
Moscow II9899, USSR

Abstract. Registration and identification of muons and muon groups penetrating into the ocean depth, can be performed using a modular multilayer detector with high resolution bidimensional readout - deep underwater calorimeter (project NADIR). Laboratory testing of a prototype sensor cell with liquid scintillator in light-tight casing, testifies to the practicability of the full-scale experiment within reasonable expences.

### Introduction

The most popular conception of DUMAND, in its optical version, is a spatial lattice with numerous PMTs in sites, serving as immediate receptors of Cherenkov radiation, produced by high energy particles in the sea water. On the experimental plane, any practical approach to such a design makes one ponder upon many an implicit circumstances, e.g. persumably unsteady operational conditions during a long-running period.

The intricate combination of natural factors - as deep-sea currents, plankton migrations, bioluminescence, etc. - would very likely result in sporadic variations of water transparency, light background, and other substantial parameters. Besides, insufficient rigidity of the whole immense construction does not exclude some accidental and intractable changes in the preset sensor geometry or orientation. All these problematic issues should not be ignored as a source of possible ambiguity in data interpretation.

### Modular Underwater Calorimeter

We have proposed /1/ a more compact apparatus, in which the sensor cells have closed sensitive volume and hence their parameters unaffected by the minute changes in outer medium. In the structural respect, these cells are metal tubes 30-50 cm in diameter and 15 m long, filled with liquid scintillator and viewed from both butt-ends by two groups of PMTs. The tubes are assembled in planes  $15 \times 15 \text{ m}^2$  fixed on rigid support frames; 6 such planes spaced 2m apart one above another with alternating tube orientation, form a calorimeter module, which contains 180-300 sensor cells with independent analogue readout.

The operation of electronics - data acquisition, processing and transient recording, autotrimming and system testing - are monitored by a local computer, which is housed in a sealed case close by the sensor array and communicates with the central control station on shore via a low-speed cable line.

The fiducial volume of such a module is  $2.10^3 \text{ m}^3$  of water, angular track resolution 30-50 mrad, energy resolution for electromagnetic bremsstrahlung showers 5-6%. A full-scale experiment should include some 100 modules, placed firm side by side on the bottom at 3 km below the ocean surface (project NADIR).

As a stand-alone experimental installation, it will allow investigation of the features of high-energy muon flux and associated characteristics of primary cosmic rays and nuclear-cascade process in Earth's atmosphere. In particular, single muon spectrum can be measured up to 100 TeV, while the data on muon groups must yield information about the chemical composition of cosmic ray radiation at energies of primary nuclei  $\sim 10 \text{ TeV/nucleon}$  /2/.

### Prototype Scintillation Sensor

At this stage, we have built and tested in laboratory a prototype sensor cell for the deep underwater calorimeter, its architecture and functions being the same as those of the practical one, except for size.

Fig. I presents a sketch of the cell construction. A light-tight casing (1) poured with liquid scintillator (whitespirit) is manufactured of thin-wall aluminium tube  $\varnothing 15 \text{ cm}$ , closed from butt-ends with plexiglass windows (2). Electronic equipment (3) is sealed in two identical aluminium containers (4) rated at high external pressure and attachable to the flanges at the opposite ends of the tube. When immersed in the water, the excess of the tube buoyancy-originating from lower density of whitespirit relative to water - is expected to compensate the effective weight of massive containers.

From each container, 3 PMTs (5) view the scintillator through a conic 5 cm thick plexiglass illuminator (6) glued into an aluminium hoop, which is adjusted to the container mouth and equipped with rubber packing rings for hermetization.

A double-conductor waterproof cable (7) connects the containers with each other, and with minicomputer "Electronica-60" serving for an "executive controller" monitored from a remote terminal. The intercommunication is carried

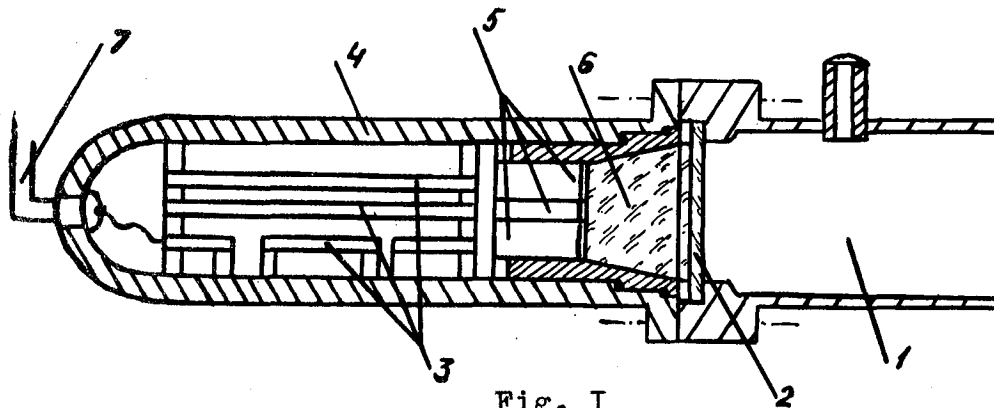

Fig. I

out at a frequency 20 kc ( $10^4$  bit/sec transmission rate). The same cable is used to supply power voltage +12 V feeding the electronic equipment.

### Electronics

The basic elements of the front-end control/data acquisition electronics are diagrammed in fig.2. It is subdivided in two twin modules, each occupying one of the two containers.

The general purpose elements available in both modules are: a power supply block (1) transforming +12 V from the supply main into stabilized +9 V, +5 V and -10 V DC; a module controller (2); an interface (3) performing data and command exchange between the modules and with the "executive controller"; a first-level majority coincidence circuit (4) firing on coincidences of at least 2 (any) of 3 PMTs; and a LED driver (5) intended for calibration of PMTs on the opposite end of the sensor cell.

Three identical PMT channels include: high-voltage converters for PMT feeding (6) with 8-bit output potential setting by means of a computer-monitored DAC (7); 12-bit PMT noise counters (8); pulse shapers (9); and 7-bit log ADCs for pulse-height digitization (10).

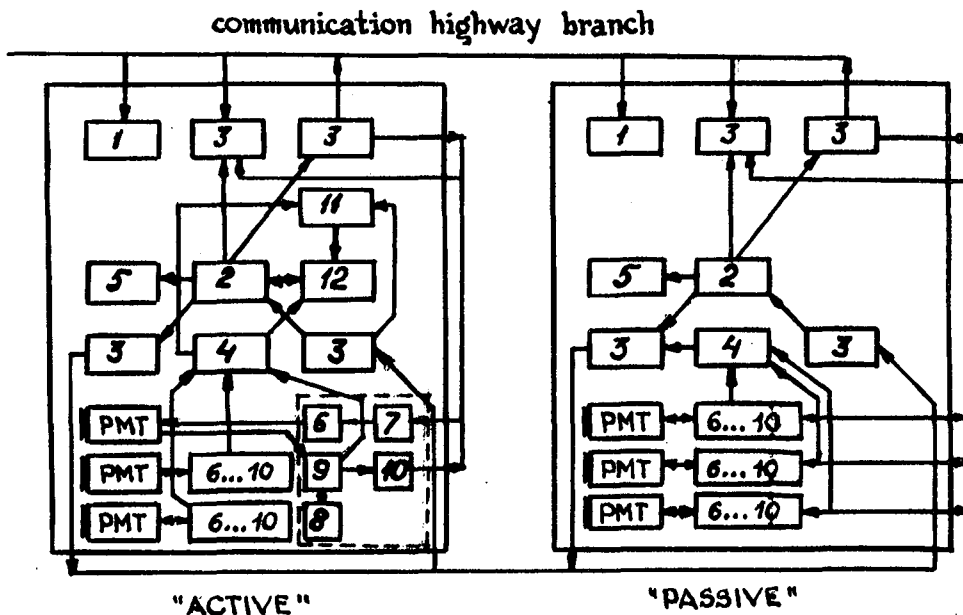

Fig. 2.

In addition, one of the modules contains a second-level (intermodular) coincidence circuit (II), and a "mask register" (I2) fitting an actual pattern of trigger bits to the computer-defined trigger-enable mask. This module (named "active") initiates a regular intercommunication cycle, addressing its counterpart (named "passive") and the "executive controller" on detecting of an "event" or routinely once every 10 sec on receipt of a timer signal.

### Laboratory Test Data

The emphasis of the laboratory testing programme was focused on the following subjects:

Technological solutions conditioned by the specificity of sensor cell operation deep in the sea water;

Realistic parameters and optimum operational rates;

Stability and reliability of electronic equipment; and

Actual money and labour consumption, in view of the prospects for serial production of like sensor cells for the full-scale experiment.

The general conclusions are that rather not elaborate a device, as that described in the preceding sections, may be running for a long period of time without logic malfunctions and significant drift of parameters. Of particular importance for this type of detector is the efficiency of light collection onto PMT's photocathode from a relatively short and distant particle track, since the optical contact between the liquid scintillator and metal cistern eliminates total internal reflection. The laboratory test data indicate that due to high transparency of whitespirit (attenuation length estimated to exceed 10 m), the reliable registration can be anticipated of a minimum ionizing particle traversing somewhere a 15m long sensor cell, with sufficient pulse-height resolution, unless the inner surface of aluminium casing is too much tarnished (reflection coefficient below 0.6) - a restriction that would hardly cause any technological problem.

On the whole, judging from the experience obtained with the prototype sensor cell, the full-scale experiment seems to be realizable within reasonable expences.

### References

1. G.L.Bashindzhagyan et al. Deep Underwater Measurements with Ionization Calorimeter. - 17th ICRC, v.7, p.I4I-I44 (Paris, 1981).
2. I.N.Vardanyan et al. Experiment "NADIR": Single Muon Spectra and Muon Groups in the Ocean Depth. - All-Union Cosmic Ray Conf. (Yakutsk, 1984) - in Russian.